

PAPER • OPEN ACCESS

Robust H_{∞} stabilization of a hard disk drive system with a single-stage actuator

To cite this article: Hendra G Harno and Raymond Song Kiin Woon 2015 *IOP Conf. Ser.: Mater. Sci. Eng.* **78** 012029

View the [article online](#) for updates and enhancements.

Related content

- [Fast electrochemical actuator](#)
I V Uvarov, A V Postnikov and V B Svetovoy
- [High Precision Tracking Control based on Pseudo-Inverse Feedforward Control System for Next-Generation Optical Disks](#)
Tokoku Ogata, Tatsuya Nakazaki, Naohide Sakimura et al.
- [Servo Technologies in a Near-Field Optical Disk Drive System](#)
Tsutomu Ishimoto, Sunmin Kim, Ariyoshi Nakaoki et al.

Robust H_∞ stabilization of a hard disk drive system with a single-stage actuator

Hendra G Harno¹ and Raymond Song Kiin Woon

Department of Mechanical Engineering, Faculty of Engineering and Science, Curtin University, CDT 250, 98009 Miri, Sarawak, Malaysia

¹ E-mail: h.g.harno@curtin.edu.my (@gmail.com)

Abstract. This paper considers a robust H_∞ control problem for a hard disk drive system with a single stage actuator. The hard disk drive system is modeled as a linear time-invariant uncertain system where its uncertain parameters and high-order dynamics are considered as uncertainties satisfying integral quadratic constraints. The robust H_∞ control problem is transformed into a nonlinear optimization problem with a pair of parameterized algebraic Riccati equations as nonconvex constraints. The nonlinear optimization problem is then solved using a differential evolution algorithm to find stabilizing solutions to the Riccati equations. These solutions are used for synthesizing an output feedback robust H_∞ controller to stabilize the hard disk drive system with a specified disturbance attenuation level.

1. Introduction

Since hard disk drives (HDD) have become portable data storage devices, disturbance rejection has been one of important features of the HDD in order to prevent shock and vibration from causing data loss and corruption; e.g., see [1]. This relates to HDD system's ability to detect the occurrence of disturbances and then to suspend reading/writing operation. One way is to apply a feedforward controller to compensate the disturbances measured by an accelerometer where phase shift of accelerometer associated with phase delay correction is used to measure disturbances; e.g., see [2]. This method has been effective in improving tracking accuracy of the HDD. Also, dual piezoelectric accelerometers has been used to measure angular acceleration when compensating disturbance effects in the HDD; see [3]. Despite the fact that the dual accelerometers may have varying sensitivity, the latter method has performed satisfactorily in rejecting rotational disturbances.

In addition to disturbance perturbation, track misregistration may also become an important concern when operating the HDD systems. This issue can be addressed by applying a dynamic output feedback controller for track-following control of a magnetic read/write head in the HDD systems. Two optimal robust control techniques: mixed H_2/H_∞ and H_2/μ -synthesis have been proposed in [4, 5] to provide different robustness. The mixed H_2/H_∞ method is a controller design method for reconciling performance and robustness against exogenous disturbances; whereas mixed H_2/μ -synthesis is to deal with structured uncertainties; see [4, 5].

¹ To whom any correspondence should be addressed.



However, these techniques result in the dynamic output feedback controllers which only deal with norm-bounded uncertainties.

In this paper, a single-stage actuator HDD is considered and represented as a linear time-invariant uncertain system. Uncertainties of the HDD system considered consist of uncertain parameters and high-order dynamics. The uncertainties are required to satisfy integral quadratic constraints (IQC), which are suitable to represent nonlinear time-varying dynamic uncertainties including the norm-bounded uncertainties; see [6]. This representation leads to the application of an IQC-based robust H_∞ control method to achieve a stable closed-loop HDD control system with a specified disturbance attenuation level; e.g., see [7]. In this method, a set of scaling constants is applied to convert a robust H_∞ control problem with IQC into a standard H_∞ control problem; see [7]. A solution the latter problem involves stabilizing solutions to a pair of algebraic Riccati equations parameterized by the scaling constants. Thus, the resulting stabilizing solutions are then used to synthesize an output feedback robust H_∞ controller having the same order as that of the HDD model.

To obtain the desired output feedback controller, the given robust H_∞ control problem is transformed into a nonlinear optimization problem with nonconvex constraints and is then solved using an evolutionary optimization approach; see [8]. This approach is realized using a differential evolution (DE) algorithm as presented in [9, 10]. It has been shown in [8] that this approach is effective in handling such a nonlinear optimization problem with nonconvex constraints arising from the robust H_∞ control problem with IQC. Note that this control problem is usually difficult to solve using a conventional nonlinear optimization method.

The DE algorithm is chosen because it is more robust against parameter variation and is simpler in implementation than other types of evolutionary algorithm such as a genetic algorithm; see [9]. Moreover, the DE algorithm tends to be more reliable and results in a simpler formulation than an linear-matrix-inequality approach with rank constraints as presented in [11] although the former algorithm is a heuristic algorithm. These considerations thus lead to the application of the DE algorithm to solve the robust H_∞ control problem for the HDD system with the evolutionary optimization approach as has also been considered in, for instance, [12].

The rest of this paper proceeds as follows. Section 2 presents the formulation of the robust H_∞ control problem for the HDD system. Section 3 describes the DE approach used to solve the robust control problem and discusses about the performance of the resulting controller. Finally, Section 5 presents concluding remarks.

2. Problem Formulation

The single-stage actuator of the HDD system is referred to as a voice coil motor (VCM) actuator which exhibits dynamical characteristics of double integrators with high-frequency resonance modes. According to [13], the dynamics of the VCM actuator can then be represented by a transfer function as follows:

$$G_v(s) = \frac{k_v k_y}{s^2} \prod_{i=1}^4 G_{v_i}(s) \quad (1)$$

where k_y is a position measurement gain and $k_v = k_t/m$ with k_t is a current-force conversion coefficient and m is the mass of the VCM actuator. Each $G_{v_i}(s)$ is a second-order transfer function having eigenvalues with negative real parts and thus, it is stable. The product of all $G_{v_i}(s)$ then results in an eighth-order transfer function which only significantly represent the VCM actuator's dynamics in a high-frequency region, which may be beyond the operational frequency range of the VCM actuator. Although the transfer function (1) does not represent nonlinear dynamics of the VCM actuator due to mechanical friction, it is sufficient for linear controller design.

2.1. Nominal plant and uncertain system model

For the purpose of designing the robust H_∞ controller as mentioned in Section 1, the VCM actuator can nominally be modeled as a linear system with double integrators as follows:

$$G_v(s) = \frac{k_v k_y}{s^2}. \quad (2)$$

In terms of state equations, the transfer function (2) can then be written as follows (see [13]):

$$\begin{bmatrix} \dot{y}(t) \\ \dot{v}(t) \end{bmatrix} = \begin{bmatrix} 0 & k_y \\ 0 & 0 \end{bmatrix} \begin{bmatrix} y(t) \\ v(t) \end{bmatrix} + \begin{bmatrix} 0 \\ k_v \end{bmatrix} u(t) \quad (3)$$

where y and v represent the position and the velocity of read/write (R/W) head, respectively; and u is the actuator (control) input. Thus, in the robust H_∞ control framework, the high-frequency resonance modes and the nonlinear dynamics of the VCM actuator can be considered as uncertainties. Note that, k_y and k_v might also be uncertain to some extent.

Based on (3), a linear time-invariant uncertain system to represent the VCM actuator can be expressed as follows:

$$\begin{aligned} \dot{x}(t) &= Ax(t) + B_1 w(t) + B_2 u(t) + B_3 \xi(t); \\ z(t) &= C_1 x(t) + D_{12} u(t); \\ \zeta(t) &= Gx(t); \\ y(t) &= C_2 x(t) + D_{21} w(t) + D_3 \xi(t) \end{aligned} \quad (4)$$

where

$$\begin{aligned} x &= \begin{bmatrix} y \\ v \end{bmatrix}; \quad w = \begin{bmatrix} w_1 \\ w_2 \end{bmatrix}; \quad \xi = \begin{bmatrix} \xi_1 \\ \xi_2 \end{bmatrix}; \quad \zeta = \begin{bmatrix} \zeta_1 \\ \zeta_2 \end{bmatrix}; \\ A &= \begin{bmatrix} 0 & 1 \\ 0 & 0 \end{bmatrix}; \quad B_1 = \begin{bmatrix} 0 & 0 \\ 1 & 0 \end{bmatrix}; \quad B_2 = \begin{bmatrix} 0 \\ 6.4013 \times 10^7 \end{bmatrix}; \\ B_3 &= \begin{bmatrix} 0.5 & 0 \\ 0 & 0 \end{bmatrix}; \quad C_1 = \begin{bmatrix} 1 & 0 \\ 0 & 0 \end{bmatrix}; \quad D_{12} = \begin{bmatrix} 0 \\ 1 \end{bmatrix}; \quad C_2 = [1 \quad 0]; \\ D_{21} &= [0 \quad 1]; \quad D_3 = [0 \quad 0.5]; \quad G = \begin{bmatrix} 0 & 1 \\ 1 & 0 \end{bmatrix}. \end{aligned} \quad (5)$$

In the state equations (4), $x \in \mathbb{R}^2$ is the state vector; $w \in \mathbb{R}^2$ is the disturbance input; $u \in \mathbb{R}$ is the control input; $\xi \in \mathbb{R}^2$ is the uncertainty input; $z \in \mathbb{R}^2$ is the controlled output; $\zeta \in \mathbb{R}^2$ is the uncertainty output; and $y \in \mathbb{R}$ is the measurement output. Moreover, in order to be admissible, the uncertainty input $\xi(t)$ and the uncertainty output $\zeta(t)$ in (4) are also required to satisfy integral quadratic constraints as follows (see [7, 6]):

$$\int_0^\infty \|\xi_i(t)\|^2 dt \leq \int_0^\infty \|\zeta_i(t)\|^2 dt + d_i, \quad \text{for } i = 1, 2 \quad (6)$$

where $d_i \geq 0$.

2.2. The closed-loop HDD control system

For the uncertain system (4), (6), the robust H_∞ output feedback controller is of the form

$$\begin{aligned} \dot{x}_c(t) &= A_c x_c(t) + B_c y(t); \\ u(t) &= C_c x_c(t). \end{aligned} \quad (7)$$

and has the same order as that of the nominal plant (3). The closed-loop HDD control system is obtained by interconnecting the controller (7) and the uncertain system (4), (6) in order to achieve absolute stabilization with a specified disturbance attenuation level $\gamma > 0$.

The uncertain system (4), (6) is thus said to be absolutely stabilizable with a specified disturbance attenuation level $\gamma > 0$ if there exists an output feedback controller (7) and constants $c_1 > 0$ and $c_2 > 0$ such that the following conditions hold (see [7]):

- (i) For any initial conditions $[x(0), x_c(0)]$, any admissible uncertainty input $\xi(\cdot)$ and any disturbance input $w(\cdot) \in \mathbb{L}_2[0, \infty)$, then

$$[x(\cdot), x_c(\cdot), u(\cdot), \xi_1(\cdot), \xi_2(\cdot)] \in \mathbb{L}_2[0, \infty)$$

and

$$\begin{aligned} & \|x(\cdot)\|_2^2 + \|x_c(\cdot)\|_2^2 + \|u(\cdot)\|_2^2 + \|\xi_1(\cdot)\|_2^2 + \|\xi_2(\cdot)\|_2^2 \\ & \leq c_1 [\|x(0)\|^2 + \|x_c(0)\|^2 + \|w(\cdot)\|_2^2 + d_1 + d_2]. \end{aligned} \tag{8}$$

- (ii) The H_∞ norm-bound condition is satisfied: If $x(0) = 0$ and $x_c(0) = 0$, then

$$\mathcal{J} := \sup_{w(\cdot) \in \mathbb{L}_2[0, \infty)} \sup_{\xi_1(\cdot), \xi_2(\cdot) \in \Xi} \frac{\|z(\cdot)\|_2^2 - c_2[d_1 + d_2]}{\|w(\cdot)\|_2^2} < \gamma^2. \tag{9}$$

Note that $\|f(\cdot)\|_2$ denotes the \mathbb{L}_2 -norm of the function $f(\cdot)$, that is $\|f(\cdot)\|_2^2 := \int_0^\infty \|f(t)\|^2 dt$; and Ξ is the set of all admissible uncertainty inputs $\xi_1(\cdot)$ and $\xi_2(\cdot)$.

If an absolutely stabilizing controller of the form (7) for the HDD system exists, then the resulting closed-loop system (as illustrated in Figure 1) can be written as follows:

$$\begin{aligned} \begin{bmatrix} \dot{x}(t) \\ \dot{x}_c(t) \end{bmatrix} &= \begin{bmatrix} A + B_3\Delta G & B_2C_c \\ B_cC_2 + B_cD_3\Delta G & A_c \end{bmatrix} \begin{bmatrix} x(t) \\ x_c(t) \end{bmatrix} + \begin{bmatrix} B_1 \\ B_cD_{21} \end{bmatrix} w(t); \\ z(t) &= [C_1 \quad D_{12}C_c] \begin{bmatrix} x(t) \\ x_c(t) \end{bmatrix} \end{aligned} \tag{10}$$

where

$$\Delta = \begin{bmatrix} \Delta_x & 0 \\ 0 & \Delta_y \end{bmatrix}; \quad \Delta_x, \Delta_y \in \mathbb{R}. \tag{11}$$

Note that $\xi(t) = \Delta\zeta(t)$; and $\|\Delta\|^2 \leq 1$, where $\|\cdot\|$ is an induced matrix norm.

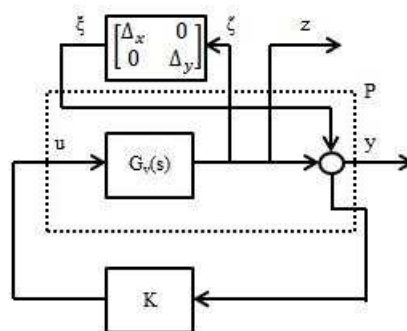

Figure 1. A closed-loop control system of the HDD with a single-stage VCM actuator.

3. Synthesis of the Robust H_∞ Controller

Synthesizing the robust H_∞ controller (7) for the uncertain system (4), (6) involves stabilizing solutions to a pair of parameterized algebraic Riccati equations presented as follows (see [7, 14]):

$$(A - B_2 E_1^{-1} \hat{D}'_{12} \hat{C}_1)' X + X(A - B_2 E_1^{-1} \hat{D}'_{12} \hat{C}_1) + X \left(\hat{B}_1 \hat{B}'_1 - B_2 E_1^{-1} B'_2 \right) X + \hat{C}'_1 (I - \hat{D}_{12} E_1^{-1} \hat{D}'_{12}) \hat{C}_1 = 0; \quad (12)$$

$$(A - \hat{B}_1 \hat{D}'_{21} E_2^{-1} C_2) Y + Y(A - \hat{B}_1 \hat{D}'_{21} E_2^{-1} C_2)' + Y \left(\hat{C}'_1 \hat{C}_1 - C'_2 E_2^{-1} C_2 \right) Y + \hat{B}_1 (I - \hat{D}'_{21} E_2^{-1} \hat{D}_{21}) \hat{B}'_1 = 0 \quad (13)$$

where

$$\begin{aligned} \hat{B}_1 &= [\gamma^{-1} B_1 \quad \sqrt{\tau_1}^{-1} B_{31} \quad \sqrt{\tau_2}^{-1} B_{32}]; \quad \hat{D}_{21} = [\gamma^{-1} D_{21} \quad \sqrt{\tau_1}^{-1} D_{31} \quad \sqrt{\tau_2}^{-1} D_{32}]; \\ \hat{C}_1 &= \begin{bmatrix} C_1 \\ \sqrt{\tau_1} G_1 \\ \sqrt{\tau_2} G_2 \end{bmatrix}; \quad \hat{D}_{12} = \begin{bmatrix} D_{12} \\ 0 \\ 0 \end{bmatrix}; \quad E_1 = \hat{D}'_{12} \hat{D}_{12}; \quad E_2 = \hat{D}_{21} \hat{D}'_{21}. \end{aligned} \quad (14)$$

Note that $\tau_1 > 0$, and $\tau_2 > 0$. In this regard, the solutions to the Riccati equations (12) and (13) are required to be positive definite, that is, $X > 0$ and $Y > 0$.

Solving the Riccati equations (12) and (13) tends to be challenging as their coefficient matrices are parameterized, and thus, lead to a nonconvex robust H_∞ control problem. Such a problem is considered to be difficult to solve using a conventional nonlinear optimization or an LMI-based approaches commonly used in robust H_∞ control applications. This concern thus becomes an underlying motivation to apply an evolutionary optimization method based on the DE algorithm (see [9, 10]) in order to find the solutions to the Riccati equations (12) and (13); see [8]. In this case, the given robust H_∞ control problem has to be transformed into a nonlinear constrained optimization problem describe as follows:

$$\min_{\gamma, \tau_1, \tau_2 \in \mathbb{R}_+} f(\gamma) \quad (15)$$

subject to the Riccati equations (12) and (13), and the stability of the resulting closed-loop system (10). Here, $f(\gamma)$ is a polynomial function of γ (for instance, $f(\gamma) = \gamma^2$) and is to be minimized with respect to γ , τ_1 , and τ_2 . Note also that \mathbb{R}_+ denotes the set of positive real numbers.

Since the DE algorithm is an evolutionary algorithm, it is heuristic and involves cross-over, mutation, and selection routines which operate on a population of candidate solutions; see [9]. Each candidate solution is evaluated through a fitness test procedure consisting of all constraints involve in the optimization problem (15), (12), (13), (10). The derivation of the fitness test procedure then follows the approach presented in [8]. Thus, solving the optimization problem (15), (12), (13), the controller matrices in (7) can be determined as follows:

$$\begin{aligned} A_c &= A + B_2 C_c - B_c C_2 + (\hat{B}_1 - B_c \hat{D}_{21}) \hat{B}'_1 X; \\ B_c &= (I - Y X)^{-1} (Y C'_2 + \hat{B}_1 \hat{D}'_{21}) E_2^{-1}; \\ C_c &= -E_1^{-1} (B'_2 X + \hat{D}'_{12} \hat{C}_1). \end{aligned} \quad (16)$$

4. Numerical Results and Discussion

Solving the optimization problem (15), (12), (13), (10) through the DE algorithm implemented on MATLAB yields the following solution:

$$\gamma = 2.7378; \quad \tau_1 = 0.0012; \quad \tau_2 = 1.3717. \quad (17)$$

Thus, the resulting robust H_∞ controller of the form (7) is given as follows:

$$\begin{aligned} A_c &= \begin{bmatrix} -4.1592 \times 10^4 & 1.0000 \\ 1.1383 \times 10^9 & -2.2409 \times 10^7 \end{bmatrix}; & B_c &= \begin{bmatrix} 4.1604 \times 10^4 \\ 1.2264 \times 10^3 \end{bmatrix}; \\ C_c &= [-17.7827 \quad -0.3501]. \end{aligned} \quad (18)$$

Interconnecting the robust H_∞ controller (7), (18) to the uncertain system (4), (6) will then provide a stable closed-loop system. As an example, for

$$\Delta = \begin{bmatrix} 1 & 0 \\ 0 & 0 \end{bmatrix}, \quad (19)$$

the resulting closed loop system (10) is asymptotically stable as its poles λ_{cl} are all negative real numbers which are shown as follows:

$$\lambda_{cl} = \begin{bmatrix} -2.24086 \times 10^7 \\ -0.00415 \times 10^7 \\ -0.00001 \times 10^7 \\ -0.0221 \end{bmatrix}. \quad (20)$$

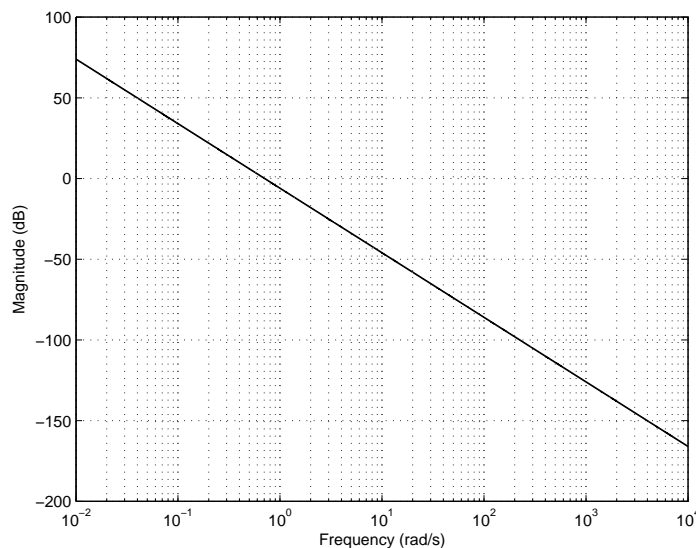

Figure 2. An open-loop frequency response of the HDD system.

The open-loop and closed-loop characteristics of the HDD control system considered can now be compared by examining the corresponding frequency responses. From Figure 2, it is apparent that the magnitude of the open-loop HDD frequency response is relatively large within the low-frequency range ($\omega < 0.7 \text{ rad/s}$) and has constant roll-off within the high-frequency range. This implies that the HDD system significantly amplifies disturbance input signals, which is undesirable when the R/W head performs track-seeking and track-following operations. This concern has been addressed through the application of the robust H_∞ controller (7), (18) to the uncertain system (4), (6), which leads to the closed-loop HDD frequency response as depicted in Figure 3. It is shown that the magnitude of the closed-loop HDD frequency response is relatively

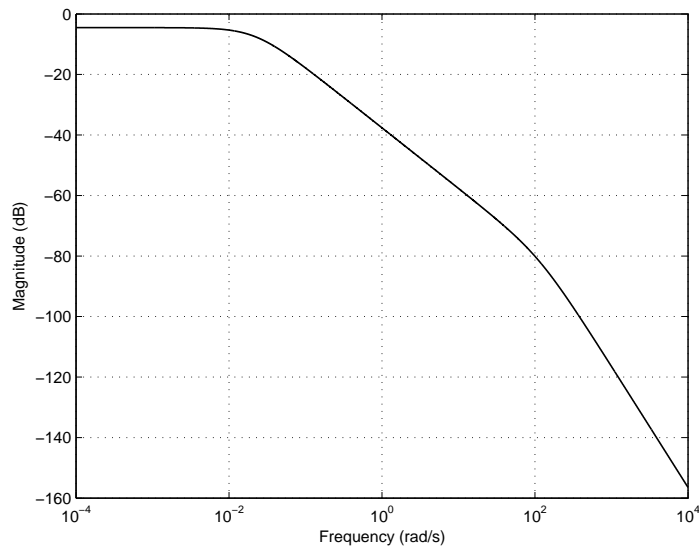

Figure 3. A closed-loop frequency response of the HDD system.

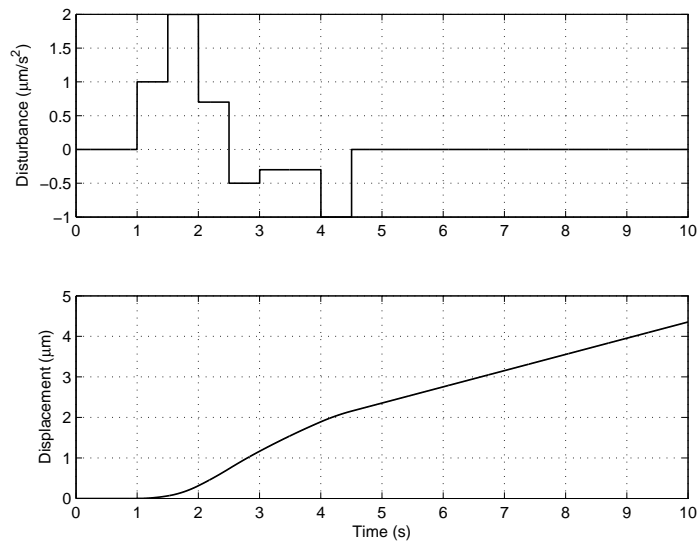

Figure 4. An open loop time response of the HDD system.

small within the low-frequency range and has steeper roll-off as the frequency getting higher. This implies that the robust H_∞ controller (7), (18) is effective in attenuating the disturbance input signals in the whole range of frequency, and thus the the closed-loop HDD system is absolutely stabilized.

Simulated open-loop and closed-loop time responses shown in Figure 4 and Figure 5 respectively confirm the open-loop and closed-loop characteristics of the HDD control system. In Figure 4, it is evident that the R/W head displacement of the open-loop HDD system continuously grows although the accelerating disturbance input has ceased. This is due to the fact that the nominal HDD system (2) has double integrators. Meanwhile, as shown in

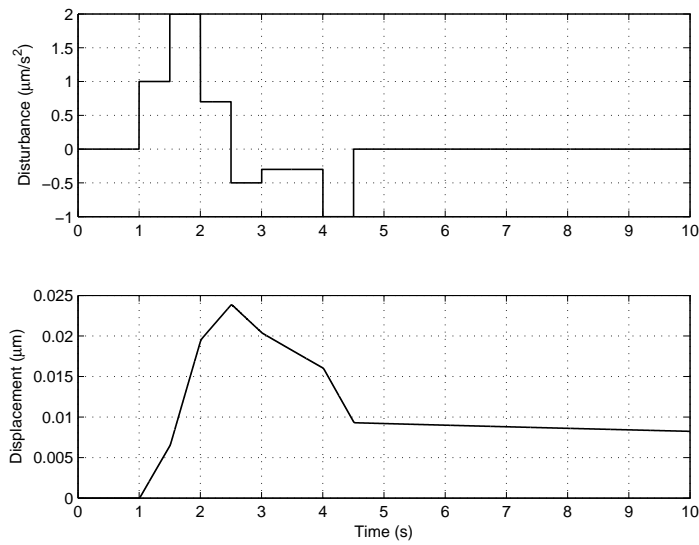

Figure 5. A closed loop time response of the HDD system.

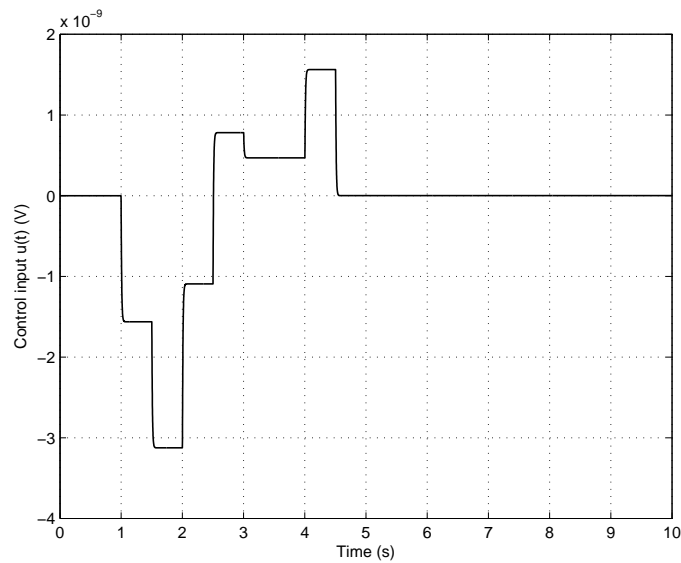

Figure 6. A control input $u(t)$ of the HDD system.

Figure 5, when the accelerating disturbance input has stopped perturbing the HDD system, the R/W head displacement of the closed-loop HDD system continuously decreases toward a much smaller magnitude than that of the open-loop HDD system. Moreover, Figure 6 also shows that the robust controller (7), (18) is efficient and has spent sufficiently small effort in order to absolutely stabilize the closed-loop HDD system perturbed by the accelerating disturbance input.

5. Conclusion

In this paper, the IQC-based robust H_∞ control problem for the HDD system has been presented. From the frequency and time responses, it has been shown that the resulting robust controller has been effective in absolutely stabilizing the closed-loop HDD system while attenuating any exogenous disturbance inputs perturbing the HDD system. Such a controller can be synthesized by using the stabilizing solutions to the pair of parameterized algebraic Riccati equations. Since the control problem considered is numerically nonconvex, the DE algorithm has been employed to solve the Riccati equations. Moreover, as a future research direction, a tracking control problem for the HDD system can be considered by extending the current results.

References

- [1] Du C, Ge S S and Lewis F L 2008 *International Journal of Adaptive Control and Signal Processing* **22** 374–387
- [2] Abramovitch D Y 1997 *Control Engineering Practice* **5** 1517–1524
- [3] Jinzenji A, Sasamoto T, Aikawa K, Yoshida S and Aruga K 2001 *IEEE Transactions on Magnetics* **37** 888–893
- [4] Du C, Xie L, Teoh J N and Guo G 2005 *IEEE Transactions on Control Systems Technology* **13** 832–839
- [5] Nagamune R, Huang X and Horowitz R 2010 *Journal of Dynamic Systems, Measurement, and Control* **132** 021005
- [6] Petersen I R, Ugrinovskii V A and Savkin A V 2000 *Robust Control Design using H^∞ Methods* (Springer-Verlag London)
- [7] Savkin A V and Petersen I R 1996 *Journal of Mathematical Systems, Estimation and Control* **6** 339–342
- [8] Harno H G and Petersen I R 2011 *International Journal of Control* **84** 665–678
- [9] Price K V, Storn R M and Lampinen J A 2005 *Differential Evolution - A Practical Approach to Global Optimization* (Berlin, Germany: Springer)
- [10] Price K V 2008 *Advances in Differential Evolution (Studies in Computational Intelligence vol 143)* ed Chakraborty U K (Berlin Heidelberg: Springer-Verlag) pp 33–88
- [11] Orsi R, Helmke U and Moore J B 2006 *Automatica* **42** 1875–1882
- [12] Tan K C, Sathikannan R, Tan W W and Loh A P 2007 *Soft Computing* **11** 131–139
- [13] Chen B M, Lee T H, Peng K and Venkataramanan V 2006 *Hard Disk Drive Servo Systems* 2nd ed (London, the UK: Springer-Verlag)
- [14] Petersen I R, Anderson B D O and Jonckheere E A 1991 *International Journal of Robust and Nonlinear Control* **1** 171–185