

School of Nursing and Midwifery

**A Randomised Comparative Crossover Study to Assess the Affect on
Circuit Life of Varying Pre-dilution Volumes Associated with
Continuous Veno-venous Haemofiltration (CVVH) and Continuous
Veno-venous Haemodiafiltration (CVVHdf)**

Hugh Thomas Davies

This thesis is presented for the Degree of

Doctor of Philosophy

of

Curtin University

June 2011

DECLARATION

To the best of my knowledge and belief this thesis contains no material previously published by any other person except where due acknowledgement has been made.

This thesis contains no material which has been accepted for the award of any other degree or diploma in any university.

Signature:

Date:

DEDICATION

I would like to dedicate my thesis to the memory of my late father and mother, Arthur and Mollie Davies. A desire to better myself through education gave them enormous pleasure. I would not have been able to complete my thesis without having had their love and encouragement.

LIST OF PUBLICATIONS BY THE AUTHOR ARISING FROM THE THESIS

- Davies, H. & Leslie, G. Acute Kidney Injury and the Critically Ill Patient. *Dimensions of Critical Care Nursing*, Article in Press.
- Davies, H., Leslie, G. & Morgan, D. Continuous renal replacement treatment and the 'bleeding patient'. *BMJ Case Reports* 2010; 10.1136/bcr.01.2009.1523, 11th January 2011.
- Davies, H. T., Leslie, G., Pereira, S. M., & Webb, S. A. R. (2008). A randomized comparative crossover study to assess the affect on circuit life of varying pre-dilution volumes associated with CVVH and CVVHDF. *International Journal of Artificial Organs*, 31(3), 221-227.
- Davies, H., Morgan, D., & Leslie, G. (2008). A regional citrate anticoagulation protocol for pre-dilutional CVVHDF: The 'Modified Alabama Protocol'. *Australian Critical Care*, 21(3), 154-165.
- Davies, H., & Leslie, G. D. (2008). Intermittent versus Continuous Renal Replacement Therapy: A matter of controversy. *Intensive and Critical Care Nursing*, 24(5), 269-285.
- Davies, H., & Leslie, G. D. (2007). Anticoagulation in CRRT: Agents and strategies in Australian ICUs. *Australian Critical Care*, 20(1), 15-26.
- Davies, H., & Leslie, G. D. (2006). Maintaining the CRRT circuit: Non-anticoagulant alternatives. *Australian Critical Care*, 19(4), 133-138.

LIST OF PRESENTATIONS MADE BY THE AUTHOR ARISING FROM THE THESIS

Nursing Free Paper, 31st Annual Scientific Meeting on Intensive Care, Hobart, 12th –
15th October 2006

*A randomised comparative crossover study to assess the affect on circuit life of varying
pre-dilution volumes associated with continuous veno-venous haemofiltration
(CVVH) and continuous veno-venous haemodiafiltration (CVVHDF)*

Nursing Poster presentation, 34th Annual Scientific Meeting on Intensive Care, Perth,
29th – 31st October 2009

The development of a pressure profile system to monitor circuit function during CRRT

Adult Program presentation, 34th Annual Scientific Meeting on Intensive Care, Perth,
29th – 31st October 2009

Citrate: Is it the 'Holy Grail' of regional anticoagulation for CRRT?

Adult Program presentation, Critical Care Nursing Continuing Education 11th Annual
Meeting, Sydney, 21st & 22nd May 2010

Dialysing the coagulopathic patient

**AWARDS RECEIVED BY THE AUTHOR ARISING FROM THE
THESIS**

Nursing Scholarship Prize, 31st Annual Scientific Meeting on Intensive Care, Hobart,
12th – 15th October 2006

*A randomised comparative crossover study to assess the affect on circuit life of varying
pre-dilution volumes associated with continuous veno-venous haemofiltration
(CVVH) and continuous veno-venous haemodiafiltration (CVVHdf)*

THESIS SUMMARY

Continuous renal replacement therapy (CRRT) is an established treatment option in Australia for critically ill patients with acute renal failure (ARF). Critical care nurses play a primary role in the set-up of equipment, monitoring and care of patients receiving CRRT. Although described as a continuous therapy, delays or interruptions in CRRT can interfere with treatment efficiency. A review of the literature identified how optimal circuit function is an important factor in determining the effectiveness of treatment and patient outcomes.

The aim of this research was to evaluate treatment efficiency in terms of circuit life between two widely used forms of CRRT, continuous veno-venous haemofiltration (CVVH) versus continuous veno-venous haemodiafiltration (CVVHDF). The investigation focused attention on the influence higher pre-dilution volumes and convective clearance of CVVH may have on circuit life when compared to the lower pre-dilution volumes and diffusive clearance required for CVVHDF.

This thesis describes how the impact of CVVH versus CVVHDF on circuit life was investigated using a randomised comparative crossover study design. Once institutional ethics committee approval had been received, 45 patients were recruited to the study who were 18 years or older and required the commencement of CRRT as part of their Intensive Care treatment. Of the 45 patients who were randomised to receive CVVH or CVVHDF, 31 patients achieved a successful crossover to the alternative technique. Failure to achieve a 'natural' circuit life – that is one which terminated due to clotting, in a CVVH *and* CVVHDF circuit accounted for the large drop out rate. Blood flow rate, vascular access device and insertion site, haemofilter, anticoagulation and machine hardware were standardised. An ultrafiltrate dose 35 millilitres (ml) per kilogram (kg) per hour (hr) delivered pre-filter was used for CVVH and a fixed pre-dilution volume of 600ml per hr with a dialysate dose of 1litre (L) was used for CVVHDF. Patients were excluded if coagulopathic, thrombocytopenic or unable to receive heparin.

Of the 31 paired comparisons there was a significant difference in circuit life measurements between CVVH and CVVHDF after a paired-sample t-test was performed following natural logarithm base-e (ln) dataset transformation (CVVH 6.101 versus CVVHDF 6.779, P-value = 0.001). A Wilcoxon signed ranks test used raw dataset

values of circuit life measurements as an alternative non-parametric comparison ($Z = -4.076$, $P\text{-value} < 0.001$). The probability of circuit survival for each treatment mode was estimated using the Kaplan-Meier method from the 93 circuits which had survived to clotting (50 CVVH circuits and 43 CVVHDF circuits). Using the truncation point of 16 hr as a measure of expected minimum survival, 50 percent (%) of CVVHDF circuits remained in operation when compared with only a 5% for CVVH circuits. The same 93 circuits were also used in a linear multiple regression analysis. None of the independent variables (activated prothrombin time, platelet count, heparin dose, patient haematocrit, urea) had a coefficient partial correlation > 0.09 (coefficient of determination = 0.117) or a linear relationship which could be associated with circuit life ($P\text{-value} = 0.228$).

The evaluation of treatment efficiency in terms of circuit life between the different techniques of CVVH and CVVHDF is of clinical importance, since each treatment mode depends upon a measure of circuit longevity to achieve adequate replacement of renal function. Numerous factors have been described which influence circuit life in the delivery of CRRT including circuit and filter design, anticoagulation and staff training and expertise. In this study a longer circuit life was reported using CVVHDF which incorporated lower pre-dilution volumes when compared with the higher pre-dilution volumes associated with CVVH. This could possibly be explained by the physical processes involved in fluid and solute transport across the filter membrane. The choice of CRRT mode is a factor which may be an important independent determinant of circuit life using the techniques of CVVH and CVVHDF. This information may influence intensive care nursing practice in respect of mode selection for CRRT in collaboration with medical colleagues.

ACKNOWLEDGEMENTS

I wish to acknowledge the Health Department of Western Australia and in particular the Nursing and Midwifery Office for providing financial assistance towards the successful completion of this study after being awarded the 'Helen Bailey Nursing Scholarship 2005'.

I would like to thank the patients and their loved-ones who gave permission to participate in the study. I am also indebted to the intensive care unit medical and nursing staff at Royal Perth Hospital who gave invaluable assistance with the conduct of the study.

I would like to express my deep gratitude to Professor Gavin Leslie as principal supervisor. My progress was made a lot easier by the willingness of Gavin to meet regularly. This was particularly important when I experienced problems in the development of my study. His enthusiasm for the project and knowledge base of critical care nursing and the specific topic of renal replacement therapy sustained me through these periods of difficulty. Feedback of work submitted for review was always prompt and criticism of content constructive. The support I received enabled me to achieve success in being awarded a prize winning scholarship. Appreciation of the contribution made to the success of the project should also be extended to my co-supervisors. Clinical Associate Professor Steve Webb gave invaluable advice on medical issues arising from the study and in the role of intensive care specialist his support of the project was much appreciated. Guidance on how best to carry out statistical analyses was provided by Dr Sandra Pereira whose counsel proved indispensable and feedback always meticulous when asked to review content.

A special thank you should finally be extended to my wife Sandra and daughter Amy. On many occasions they have endured long hours without my participation in family life. Both have given me so much understanding and encouragement towards the completion of my thesis.

TABLE OF CONTENTS

DECLARATION.....	II
DEDICATION.....	III
LIST OF PUBLICATIONS BY THE AUTHOR ARISING FROM THE THESIS	IV
LIST OF PRESENTATIONS MADE BY THE AUTHOR ARISING FROM THE THESIS	V
AWARDS RECEIVED BY THE AUTHOR ARISING FROM THE THESIS	VI
THESIS SUMMARY	VII
ACKNOWLEDGEMENTS.....	IX
TABLE OF CONTENTS.....	X
LIST OF TABLES	XV
LIST OF FIGURES	XVI
GLOSSARY OF TERMS	XVIII
CHAPTER 1 INTRODUCTION	1
Research Aim	4
Significance of Study	4
Background	5
<i>Acute Kidney Injury.....</i>	<i>5</i>
<i>Major Functions of the Kidney</i>	<i>6</i>
<i>Glomerular Filtration</i>	<i>6</i>
<i>Tubular Reabsorption and Secretion</i>	<i>8</i>
<i>Proximal tubule.....</i>	<i>9</i>
<i>Loop of Henle.....</i>	<i>9</i>
<i>Distal tubule.....</i>	<i>10</i>
<i>Collecting tubule.....</i>	<i>10</i>
<i>Regulation of Water and Electrolytes</i>	<i>11</i>
<i>Maintenance of Acid-Base Balance</i>	<i>12</i>
<i>Definition and Classification of Acute Kidney Injury.....</i>	<i>13</i>
<i>Causes of Acute Kidney Injury.....</i>	<i>17</i>
<i>Prerenal Injury.....</i>	<i>18</i>
<i>Intrarenal Injury</i>	<i>18</i>
<i>Postrenal Injury</i>	<i>18</i>
<i>Pathophysiology of Acute Tubular Necrosis.....</i>	<i>19</i>
<i>Epidemiology of Acute Kidney Injury</i>	<i>22</i>
<i>Consequences of Acute Kidney Injury.....</i>	<i>25</i>
<i>Volume overload</i>	<i>25</i>
<i>Electrolyte disorders</i>	<i>26</i>
<i>Retention of organic compounds.....</i>	<i>27</i>

<i>Metabolic acidosis</i>	28
<i>Protective Strategies</i>	28
<i>Cardiac output</i>	29
<i>Expansion of intravascular fluid volume</i>	30
<i>Renal perfusion pressure</i>	32
<i>Pharmacologic Agents</i>	34
<i>Diuretics</i>	34
<i>Low-dose Dopamine</i>	37
<i>N-acetylcysteine</i>	37
Summary	38
CHAPTER 2 LITERATURE REVIEW	40
Management of Severe ARF in the Critically Ill Patient	42
<i>Mechanisms of Solute and Plasma Water Transport</i>	43
<i>Diffusion</i>	44
<i>Convection</i>	45
<i>Ultrafiltration</i>	46
<i>Adsorption</i>	47
<i>Artificial Kidney</i>	49
<i>Artificial Membranes</i>	50
<i>Extracorporeal Renal Replacement Therapy</i>	52
<i>Early rather than late?</i>	52
<i>Intermittent Haemodialysis</i>	55
<i>Continuous Renal Replacement Therapy</i>	56
<i>History and Development</i>	56
<i>Contemporary Treatment Modes</i>	59
<i>Intermittent versus Continuous Renal Replacement Therapy</i>	64
<i>Effect on mortality and recovery of renal function</i>	65
<i>Effectiveness of Both Approaches</i>	66
<i>Solute control and restoration of acid-base balance</i>	66
<i>Drug clearance and dose adjustment</i>	72
<i>Fluid regulation and nutrition</i>	75
<i>Removal of inflammatory mediators</i>	75
<i>Cost</i>	78
<i>Complications using each approach</i>	78
<i>Haemodynamic stability</i>	80
<i>Bleeding</i>	81
<i>Immobilisation</i>	81
<i>Hybrid Therapies</i>	83
Application of Continuous Renal Replacement Therapy.....	85
<i>Choice of Treatment Mode</i>	86
<i>Dialysate and Replacement Fluid Composition</i>	87
<i>Adequacy of Treatment Dose</i>	90
<i>Factors Which Affect Circuit Life</i>	95
<i>Blood Coagulation and Extracorporeal Circulation</i>	96
<i>Anticoagulation Strategies</i>	98
<i>Unfractionated Heparin</i>	98
<i>Regional Heparinisation</i>	101
<i>Low-Molecular-Weight Heparins</i>	101
<i>Heparinoids</i>	103
<i>Regional Citrate</i>	103
<i>Platelet-Inhibiting Agents</i>	107

<i>Thrombin Antagonists</i>	108
<i>No Anticoagulation</i>	110
<i>Replacement Fluid – administration site in the extracorporeal circuit</i>	114
<i>Pre-dilution</i>	114
<i>Post-dilution</i>	115
<i>Theoretical and Operational Training</i>	116
<i>Monitoring Circuit Pressures</i>	116
<i>Circuit Design</i>	117
<i>Roller Pump</i>	118
<i>Haemofilter</i>	118
<i>Venous bubble or air-trap</i>	120
<i>Venous Access Catheter</i>	121
<i>Vascular Insertion Site</i>	122
<i>Blood Flow</i>	123
<i>Importance of Circuit Life</i>	125
Summary	127
CHAPTER 3 CONCEPTUAL FRAMEWORK	130
Concept Mapping and the Development of a Conceptual Framework	130
Interdependency between Physiological and Mechanical Factors.....	131
Longevity of the Circuit and the Conceptual Framework.....	133
CHAPTER 4 RESEARCH DESIGN AND METHODOLOGY	135
Sample.....	135
Setting	138
Equipment	140
Design	143
<i>Cross-over study design</i>	143
<i>Allocation of patients to treatments</i>	147
<i>Randomisation</i>	147
Process	149
<i>Determinants of a ‘Natural’ Circuit Life</i>	150
<i>Crossover Procedure</i>	151
<i>Standardisation of Variables</i>	159
<i>Technique</i>	159
<i>Venous Access Catheter and Vascular Insertion Site</i>	160
<i>Anticoagulation</i>	160
Training and Supervision	160
Statistical Analysis	162
<i>Database Development</i>	162
<i>Intention-to-Treat Principle</i>	163
<i>Sample Size Calculation</i>	164
<i>Assessing Normality</i>	165
<i>Paired-sample t-test</i>	167
<i>Wilcoxon Signed Ranks Test</i>	167
<i>Survival Analysis</i>	167
<i>Multiple Regression Analysis</i>	168
<i>Pearson’s product-moment correlation</i>	169
<i>Spearman’s Rank Order Correlation</i>	170
Design Limitations	170
Ethical Issues.....	170
Summary	172

CHAPTER 5 RESULTS	174
Patient Characteristics	174
Randomisation	176
‘Natural’ Circuit Life	177
Normality Tests	180
Sequential Treatment Crossovers.....	183
<i>Pre-dilution Volume and Treatment Mode</i>	183
<i>Circuit Life during CVVH and CVVHDF</i>	186
<i>Comparison of Circuit Life</i>	187
<i>Paired-sample t-test</i>	187
<i>Wilcoxon Signed Ranks Test</i>	188
Survival Analysis	189
A Multiple Linear Regression Analysis	190
<i>Pearson’s product-moment correlation</i>	192
<i>Spearman’s Rank Order Correlation</i>	196
Summary	198
CHAPTER 6 DISCUSSION.....	199
Circuit Life with CVVH and CVVHDF	201
Conceptual Framework Revisited	202
Solute Transport and Plasma Water Removal	202
Strengths and Weaknesses	206
<i>Study Design</i>	206
<i>Education and Training</i>	211
Summary	212
CHAPTER 7 CONCLUSIONS & RECOMMENDATIONS.....	214
Concluding Comments	214
Recommendations for Future Research	215
REFERENCES.....	218
APPENDIX A MATERIAL SOURCED FOR THE LITERATURE REVIEW... 250	
Review Articles	250
Meta-analyses.....	258
Randomised Controlled Trials	259
Prospective Observational Studies	264
Retrospective Observational Studies	274
Surveys.....	276
Case Reports	277
Quality Assurance Projects	277
Editorial/Viewpoints	277
APPENDIX B OUTPUT OF RANDOM NUMBERS.....	278
APPENDIX C PATIENT CONSENT FORMS.....	280
A RANDOMISED COMPARATIVE CROSSOVER STUDY TO ASSESS THE AFFECT ON CIRCUIT LIFE OF VARYING PRE-DILUTION VOLUMES ASSOCIATED WITH CONTINUOUS VENO-VENOUS HAEMOFILTRATION (CVVH) AND CONTINUOUS VENO-VENOUS HAEMODIAFILTRATION (CVVHDF).....	280
Information Sheet and Consent Form (Patient)	280

<i>Trial Summary</i>	280
<i>Your Role In The Study</i>	281
<i>Risks Associated With The Study</i>	281
<i>Voluntary Participation</i>	281
<i>Further Information</i>	282

CONSENT TO PARTICIPATION IN A STUDY TO INVESTIGATE THE AFFECT ON CIRCUIT LIFE OF VARYING PRE-DILUTION VOLUMES ASSOCIATED WITH CONTINUOUS VENO-VENOUS HAEMOFILTRATION (CVVH) AND CONTINUOUS VENO-VENOUS HAEMODIAFILTRATION (CVVHDF).	283
--	------------

A RANDOMISED COMPARATIVE CROSSOVER STUDY TO ASSESS THE AFFECT ON CIRCUIT LIFE OF VARYING PRE-DILUTION VOLUMES ASSOCIATED WITH CONTINUOUS VENO-VENOUS HAEMOFILTRATION (CVVH) AND CONTINUOUS VENO-VENOUS HAEMODIAFILTRATION (CVVHDF).	284
--	------------

Information Sheet and Consent Form (Next-of-Kin).....	284
<i>Trial Summary</i>	284
<i>Your Relative's Role In The Study</i>	285
<i>Risks Associated With The Study</i>	285
<i>Voluntary Participation</i>	285
<i>Further Information</i>	286

CONSENT TO PARTICIPATION IN A STUDY TO INVESTIGATE THE AFFECT ON CIRCUIT LIFE OF VARYING PRE-DILUTION VOLUMES ASSOCIATED WITH CONTINUOUS VENO-VENOUS HAEMOFILTRATION (CVVH) AND CONTINUOUS VENO-VENOUS HAEMODIAFILTRATION (CVVHDF).	287
--	------------

LIST OF TABLES

Table 2.1: <i>A summary of studies comparing CRRT with IHD on mortality and recovery of renal function included in narrative review</i>	68
Table 2.2: <i>A summary of studies comparing CRRT with IHD on solute control and restoration of acid-base balance included in narrative review</i>	73
Table 2.3: <i>A summary of one study comparing CRRT and IHD on fluid regulation included in narrative review</i>	76
Table 2.4: <i>A summary of one study comparing the cost between CRRT and IHD included in narrative review</i>	79
Table 2.5: <i>A summary of studies comparing CRRT and IHD on haemodynamic stability included in narrative review</i>	82
Table 2.6: <i>A summary of the mode of action and major advantages and disadvantages of anticoagulants used in Australia to anticoagulate the CRRT circuit</i>	112
Table 2.7 <i>Physiological and mechanical factors affecting circuit life</i>	124
Table 4.1 <i>Selection criteria</i>	137
Table 5.1 <i>Patient Characteristics</i>	175
Table 5.2 <i>The Kolmogorov-Smirnov goodness-of-fit statistical test for all circuit life measured in minutes</i>	180
Table 5.3 <i>The Kolmogorov-Smirnov goodness-of-fit statistical test for all circuit life measurements after natural logarithm base e transformation (ln)</i>	182
Table 5.4 <i>Differences in pre-dilution volume of successful treatment crossovers according to body weight (CVVH) compared with a fixed pre-dilution volume of 600ml (CVVHDF)</i>	185
Table 5.5 <i>Descriptive statistics of circuit life during CVVH and CVVHDF</i>	186
Table 5.6 <i>The transformed means and standard deviations (SD) for circuit life (CVVH and CVVHDF)</i>	187
Table 5.7 <i>The parametric paired-sample t-test for 31 transformed comparisons of CVVH and CVVHDF circuit life</i>	188
Table 5.8 <i>The non-parametric Wilcoxon signed ranks test for 31 comparisons of CVVH and CVVHDF circuit life</i>	188
Table 5.10 <i>The model summary of the multiple linear regression analysis showing the degree of variance in the dependent variable of circuit life which could be attributed to the independent variables of aPTT, platelets, heparin dose, haematocrit and urea</i>	195
Table 5.11 <i>Analysis of variance (ANOVA) between the dependent variable of circuit life and the independent variables of aPTT, platelets, heparin dose, haematocrit and urea</i>	195
Table 5.12 <i>Estimated standardised coefficients (Beta values) for each independent variable</i>	196
Table 5.13 <i>The bivariate linear Spearman's Rank Order Correlation between the continuous dependent variable of circuit life and the converted measurements of the independent variables of aPTT, platelets, heparin dose, haematocrit and urea (Note that all the measurement units have been converted to the same scale).</i>	197
Table 6.1 <i>Variability of dose delivery using the example of a 70kg patient in effluent volume required for CVVH and CVVHDF</i>	210
Table 6.2 <i>Variability of dose delivery using the example of a 100kg patient in effluent volume required for CVVH and CVVHDF</i>	210

LIST OF FIGURES

<i>Figure 1.1.</i> An illustration of the Nephron showing the four segments of the tubular system.....	9
<i>Figure 1.2.</i> The RIFLE classification system (Bellomo, et al., 2004)	16
<i>Figure 2.1.</i> The Classification of Extracorporeal Renal Replacement Therapies.....	43
<i>Figure 2.2.</i> An illustration of solute movement by diffusion.	45
<i>Figure 2.3.</i> An illustration of solute movement by convection.	46
<i>Figure 2.4.</i> An illustration of plasma water movement by ultrafiltration.....	47
<i>Figure 2.5.</i> An illustration showing the movement of solutes and absorption along the semi-permeable membrane.	48
<i>Figure 2.6.</i> An illustration of slow continuous ultrafiltration.....	61
<i>Figure 2.7.</i> An illustration of continuous veno-venous haemofiltration.....	62
<i>Figure 2.8.</i> An illustration of continuous veno-venous haemodialysis.	62
<i>Figure 2.9.</i> An illustration of continuous veno-venous haemodiafiltration.....	63
<i>Figure 2.10.</i> Regional citrate anticoagulation for continuous veno-venous haemodiafiltration.	105
<i>Figure 2.11.</i> Key areas of the veno-venous circuit which activate the coagulation pathway and lead to the development of blood clots.	118
<i>Figure 3.1.</i> An illustration of the Conceptual Framework.....	134
<i>Figure 4.1.</i> Flowchart showing how the research process was followed during the investigation.	136
<i>Figure 4.2.</i> The Hygieia ‘Plus’ CRRT machine (KIMAL plc, Middlesex, England)...	140
<i>Figure 4.3.</i> An illustration of the differences in the layout between CVVH and CVVHdf circuit configurations.....	142
<i>Figure 4.4.</i> A successful crossover between CVVH and CVVHDF.	152
<i>Figure 4.5.</i> An unsuccessful crossover.	153
<i>Figure 4.6.</i> Crossover interrupted by vascular access problems.....	154
<i>Figure 4.7.</i> Crossover interrupted by the administration of 0.9% normal saline.....	155
<i>Figure 4.8.</i> Crossover interrupted after alterations were made to pre-dilution volume during CVVHdf.....	157
<i>Figure 4.9.</i> Crossover prevented due to return of urinary output and restoration of renal function.	158
<i>Figure 4.10.</i> Crossover prevented due to death of patient.	159
<i>Figure 5.1.</i> Mode of treatment distribution following initial randomisation and the number of successful versus unsuccessful treatment crossovers.	177
<i>Figure 5.2.</i> The circuit life of the 93 circuits which achieved a natural circuit life either in isolation or as part of a crossover.....	179
<i>Figure 5.3.</i> Circuit life measurements displayed as a scatter plot against expected measurements for a normal distribution.....	181
<i>Figure 5.4.</i> Circuit life measurements displayed as a scatter plot following natural logarithm base e (ln) dataset transformation against expected measurements for a normal distribution.	182
<i>Figure 5.5.</i> The pattern of paired difference in circuit life between CVVH and CVVHdf for 31 patients who received both techniques sequentially after each circuit had achieved a natural circuit life.	184
<i>Figure 5.6.</i> The Kaplan-Meier (percentage cumulative) survival curves for CVVH and CVVHdf treatment modes (Note the fixed truncation time line at 960 minutes was based on earlier data from the study site).....	189

<i>Figure 5.7.</i> The hazard or failure rate of circuit survival between CVVH and CVVHDf.	190
<i>Figure 5.8.</i> The Normal Probability Plot of the natural logarithm base e (ln) circuit life measurements for the residual differences between the obtained and predicted values.....	191
<i>Figure 5.9.</i> Scatter plot of residual measurements against predicted values of the dependent variable.	192
<i>Figure 6.1.</i> An illustration of CVVH using convection to achieve solute clearance shows protein adherence and fouling of the membrane may be increased due to greater reliance on the movement of plasma water.....	203
<i>Figure 6.2.</i> An illustration of CVVHDf using primarily diffusion to achieve solute clearance shows protein adherence and fouling of the membrane may be decreased due to less reliance on the movement of plasma water	204
<i>Figure 6.3.</i> An illustration of red blood cells trapped within a fibrin mesh causing the formation of a stable clot and increased aggregation of platelets	205

GLOSSARY OF TERMS

Solute:

A substance dissolved in plasma water (for example, sodium chloride).

Semi-permeable membrane:

A barrier made from synthetic material which allows the movement of solutes and plasma water to pass through, but prevents the cellular components of plasma and other larger molecules from leaving the blood compartment.

Diffusion:

The movement of solutes through a semi-permeable membrane governed by a concentration gradient between blood and dialysate.

Convection:

The movement of solutes through a semi-permeable membrane governed by a pressure gradient between the fluid and blood compartments on either side of the membrane.

Ultrafiltration:

The removal of plasma water from blood across a semi-permeable membrane.

Veno-venous:

The outflow of blood from a vein and the inflow of blood to a vein.

Continuous Veno-venous Haemofiltration (CVVH):

A technique used for the removal of solutes and plasma water in support of renal function. Solute removal is achieved by convection.

Continuous Veno-venous Haemodiafiltration (CVVHDF):

A technique used for the removal of solutes and plasma water in support of renal function. Solute removal is achieved by diffusion and convection.

Extracorporeal Circuit:

A hollow tube made from non-biological materials for the circulation of blood outside of the body.

Artificial Kidney (blood filtration device):

A device connected to the extracorporeal circuit for the channelling of blood through bundles of hollow fibres to facilitate the movement of solutes by diffusion and convection and plasma water by ultrafiltration.

Dialysate:

A solution containing a lower concentration of solutes when compared with the patient's blood to facilitate solute removal by diffusion.

Replacement Fluid:

A solution composed of electrolytes and other important substances used for the purposes of replacing plasma water lost through the process of ultrafiltration.

Pre-dilution:

The administration of replacement fluid into the extracorporeal circuit before the blood filtration device.

Post-dilution:

The administration of replacement fluid into the extracorporeal circuit after the blood filtration device.

Effluent:

The volume of fluid discarded from the patient as blood is circulated through the extracorporeal circuit and fluid is drained away in the form of ultrafiltrate and 'spent' dialysate.

Circuit Function:

The ability of the extracorporeal circuit and blood filtration device to operate without decreasing the capacity of the circuit to achieve solute clearance and fluid removal.

'Natural' Circuit Life:

The spontaneous appearance of circuit failure caused by the accumulation of blood clots along different sections of the extracorporeal circuit.

Circuit Failure:

The inability to establish and maintain sufficient blood flow through the extracorporeal circuit.

CHAPTER 1

INTRODUCTION

Acute renal failure (ARF) is a condition which can complicate the recovery of critically ill patients, lengthen the number of days spent in hospital and ultimately contribute to patient mortality (Abernethy & Lieberthal, 2002). The condition is defined as a sudden loss of renal function causing the retention of excess fluid, the development of biochemical imbalances and/or the accumulation of metabolic waste products. The causes of ARF in the critically ill patient are primarily due to inflammatory, ischaemic or toxic events, either having occurred in isolation or in association with the failure of several organs. The condition is potentially recoverable provided the affected kidneys are treated and complications of renal insufficiency avoided. The temporary loss of renal function can be overcome by technology replacing many important functions of the kidney, either short or long-term. In the event of severe damage to the kidneys and irreversible loss of adequate renal function, the option of kidney transplantation is considered once a suitable donor is found.

The development of hospital-acquired ARF has been observed to occur in hospitalised patients including those who require intensive care admission. Over the duration of a prospective European epidemiologic study the yearly incidence of ARF for intensive care patients was reported to be 95 cases per million of population (Liano, Junco, Pascual, Madero, & Verde, 1998). During a three month survey of intensive care patients in Australia it was estimated each year 2% of the adult population (80 per million of population) had severe ARF which required the instigation of Renal Replacement Therapy (RRT) (Silvester, Bellomo, & Cole, 2001).

In situations of severe ARF some form of RRT is required until adequate renal function returns or if there is permanent loss of kidney function requiring long term management. Renal replacement therapy is defined by the Australia and New Zealand Dialysis and Transplant Registry (The 30th ANZDATA Registry Report, 2007) as a collection of treatments which include kidney transplantation, but is more commonly used to describe treatments which 'artificially' take over the biochemical and fluid regulatory functions of the kidney (Foot & Fraser, 2005). The removal of metabolic waste products and the maintenance of water and electrolyte balance can either be

achieved using peritoneal dialysis or by the circulation of blood outside of the body through a semi-permeable membrane.

The requirement for RRT in the critically ill patient was the subject of investigation reported by the Beginning and Ending Supportive Therapy (BEST) prospective multinational, multi-centre observational kidney study (Uchino et al., 2005). Although the use of RRT ranged between 4.0 and 4.4 percent (%) from the total number of patients admitted to the Intensive Care Unit (ICU), the commencement of RRT was associated with a decline in both patient survival and recovery of renal function. The hospital mortality rate of patients admitted over the duration of the BEST study that required RRT as part of their treatment in ICU was around 60%. In the case of Australia, a hospital mortality of 53.4% was reported from the six participating centres. Of those who had survived in different regions of the developed world, 11.2 to 16.3% of patients at the time of discharge from hospital were dependent on some form of RRT using peritoneal dialysis or haemodialysis.

The high mortality associated with severe ARF can be misleading, since the condition usually occurs in conjunction with other failing organs. The inability of other organs to function normally can have a greater influence on patient survival than the development of renal insufficiency alone. With the advent of modern-day RRT techniques the management of ARF is now rarely the single cause of death, but is instead the consequence of systemic illness and the kidneys' repeated exposure to injury. How best to treat the critically ill patient with severe ARF and the impact of choice of RRT may have on patient outcome, is the subject of controversy and on-going investigation (Tonelli, Manns, & Feller-Kopman, 2002). The approach can either be intermittent haemodialysis (IHD) or continuous renal replacement therapy (CRRT). In the Veterans Affairs/National Institutes of Health Acute Renal Failure Trial Network (ATN) study (2008) CRRT was the preferred technique used in patients who were haemodynamically unstable. Several operational features of CRRT allow this technique to be tolerated more easily in the critically ill patient.

Continuous renal replacement therapy is widely used in different regions of the world for the management of critically ill patients with severe ARF (Uchino et al., 2007). The techniques of continuous veno-venous haemofiltration (CVVH) and continuous veno-venous haemodiafiltration (CVVHDF) are two different forms of CRRT which effectively manage the removal of unwanted solutes and excessive fluid to

achieve metabolic and fluid volume control (Hall & Fox, 2006). The treatment mode of CVVH is a convective-based technique (removal of plasma water and dissolved wastes) in comparison to the diffusive-based technique of CVVHDF (removal of wastes across a concentration gradient). In order to manage ARF in the critically ill patient the effectiveness of both techniques is dependent on maintaining continuity of treatment.

The majority of incidents which interrupt the continuous nature of CRRT are caused by the development of blood clots in the extracorporeal circuit as a consequence of blood exposure to non-biological surfaces (Davenport, 1997). A number of interventions have been identified as strategies which can delay clotting and improve the duration of circuit life. These include ensuring the reliability of blood flow from the vascular access device (Baldwin, Bellomo, & Koch, 2004), the use of anticoagulant agents (Davies & Leslie, 2007), and the addition of replacement fluid before the haemofilter; pre-dilution mode (Uchino, Fealy, Baldwin, Morimatsu, & Bellomo, 2003b; van der Voort et al., 2005). Several authors suggest the choice of CRRT mode can affect circuit life, given the different life spans of circuits between convection-based and diffusion-based techniques (Davenport, 1998; Joannidis & Oudemans-Van Straaten, 2007). If this is so, then selection of treatment mode may be an important consideration in an overall management strategy aimed at extending circuit life and continuity of treatment.

In this thesis the impact of treatment choice on circuit life was evaluated using the techniques of CVVH and CVVHDF. The evaluation of both approaches occurred in the context of the critically ill patient who as part of their treatment in ICU required CRRT. Observations of potential differences in circuit life between CVVH and CVVHDF provide the opportunity to improve treatment delivery in the support of renal function. The thesis describes how the measurement of circuit life was achieved using a rigorous approach in the methodology adopted for the investigation. To reach a clearer understanding of how best to carry out the investigation it was necessary to obtain background information on the subject of severe ARF, undertake a review of the reasons behind why in some cases there is preference for CRRT when compared with other approaches, investigate specific aspects regarding application of the technique in clinical practice, and develop a conceptual framework based on factors which are known to influence circuit life.

Research Aim

The primary aim of this research project was to evaluate two related treatment modes of CRRT in order to better inform decision making around treatment modes in relation to circuit longevity. More specifically, the effect of a higher pre-dilution volume associated with CVVH on circuit life was compared to a lower pre-dilution volume associated with CVVHdf.

Significance of Study

The management of ARF using CRRT is affected when the duration of treatment able to be delivered to the patient is decreased. Investigation of the duration in treatment down-time was shown to adversely influence azotemic control when the continuous nature of CRRT was interrupted and the setup of a new circuit delayed the recommencement of treatment (Uchino, Fealy, Baldwin, Morimatsu, & Bellomo, 2003a). A prolonged period of treatment down-time causes the temporary suspension of the technique which can adversely impact the clinical course of patients when as a result of the delay azotemic control is reduced. The degree of dose intensity of ultrafiltrate able to be applied using CVVH has been shown to influence the outcome of critically ill patients (Ronco et al., 2000).

The extension of circuit life is an important factor to consider when attempts are made to improve the effectiveness of CRRT and maximise the treatment dose the patient is able to receive. A decision on what is an adequate circuit life when anticoagulation of the circuit is able to be used safely has not been validated by formal investigation. Experience using CVVH suggests treatment within a 24 hour (hr) cycle which is less than 16hr reduces the ability of the technique to achieve azotemic stability (Uchino, et al., 2003a). The ability of CRRT to operate 'continuously' for a length of time ensures the quality of renal support delivered to the patient is maintained. It will also reduce the workload of nursing activity required in the setup of a new circuit, allow for the containment of costs associated with single-use items, and reduce the amount of blood which is lost due to circuit failure (Joannidis & Oudemans-Van Straaten, 2007). The overall impact of a shortened circuit lifespan represents a threat in the successful application of CRRT for those patients admitted to the ICU with complex medical problems. Not only impacting on the prospect of patient recovery from renal insufficiency but also affecting the ability of the nurse to respond to other patients care

needs and in the management of hospital resources constrained by concerns over budgetary expenditure.

Background

A discussion on why critically ill patients may require CRRT is provided here before the literature surrounding the use of the technique is reviewed in the next chapter. In looking at the vulnerability of patients in ICU who develop renal insufficiency background information is given on the major functions of the kidney. This is followed by commentary on how injury to the kidney is defined with the causes and prevalence of the disease a main feature of critical illness. Once injury to the organ has been sustained recovery of the critically ill patient is threatened by a decline in kidney function. A number of interventions are discussed which seek to protect or prevent further injury to the kidneys before the commencement of CRRT becomes necessary.

Acute Kidney Injury

Acute kidney injury (AKI) refers to the entire spectrum of renal insufficiency and describes a pathological event which causes functional or structural changes to the kidneys (Kellum, Bellomo, & Ronco, 2007). The term has recently been adopted in an attempt to reach a consensus on a common quantitative definition and classification of ARF. The change of emphasis away from the terminology of describing only the presence of organ failure is also in recognition of observations which have shown small decreases in kidney function are predictive of a worse outcome when compared with patients who sustain no injury (Levy, Viscoli, & Horwitz, 1996).

In Australia between 1996-2005 there has been an estimated 2.8 percent (%) annual increase in the reporting of AKI 24hr after admission to the ICU (Bagshaw, George, & Bellomo, 2007). This rise of ICU related AKI has also occurred in other regions of the world following the expanded use of diagnostic intravenous radio contrast agents and the admission of patients who have pre-existing chronic diseases which increase the prevalence of risk factors associated with the condition (Nash, Hafeez, & Hou, 2002). The development of AKI is a major complication of critical illness where single or multiple episodes cause an abrupt decline in kidney function. The loss of kidney function can be detrimental to the management and outcome of critically ill patients which affects the ability of the body to maintain normal physiological processes and interrupts the activity of other organ systems of the body. The use of technology to

avoid the effects of severe ARF as a consequence of AKI requires the major functions of the kidney concerned with the regulation of fluid and electrolytes, the maintenance of acid-base balance and removal of metabolic waste products to be artificially replaced.

Major Functions of the Kidney

The major functions of the kidney are concerned with maintaining the body's internal environment vital for cellular activity and normal operation of other organs. The functional unit of the kidney is the nephron which uses glomerular filtration and tubular reabsorption and secretion to produce urine as a way to balance fluid volume, conserve important nutrients and remove substances and fluid not required out of the body. The kidneys receive external signals from other body systems which activate changes in the regulation of water and electrolytes and in the maintenance of acid-base balance. An understanding of how these physiological processes work is important and necessary to appreciate the limitations as well as the benefits of instigating RRT in the critically ill patient.

Glomerular Filtration

The nephron contains two capillary beds separated by a pressure gradient (Chmielewski, 2003). Blood from the branches of the renal artery and ending as afferent arterioles enter into a network of capillaries looped together referred to as the glomerulus. After blood has circulated through the first bed of capillaries it leaves the glomerulus via the efferent arteriole. Vaso-constriction of the efferent arteriole creates hydrostatic pressure within the network of capillaries which favours filtration through the Bowman's capsule. The Bowman's capsule is a hollow tube which encircles the bundle of glomerular capillaries. The filtrate produced from the network of capillaries drains into the Bowman's space and passes through into the tubular system. The efferent arterioles then continue on to surround the tubular system as the peritubular network (Chmielewski, 2003). The glomerular filtrate is almost entirely returned to the bloodstream through the network of peritubular capillaries which operate at comparatively low pressures to facilitate the reabsorption of fluid and solutes. The driving force of filtration through the glomerular network of capillaries is maintained by the capacity to sustain hydrostatic pressure. The glomerular filtration rate (GFR) is influenced by the degree of hydrostatic pressure derived from renal blood flow and the subsequent movement of fluid through the capillaries. In response to a change in arterial blood pressure a process called autoregulation maintains renal blood flow and GFR at

relatively constant levels by the constriction or dilation of the afferent and efferent arterioles (Holechek, 2003b).

The walls of glomerular capillaries are highly porous with the membrane comprising of several layers which allow only specific substances to pass through the filtration barrier (Holechek, 2003a). Substances which are filtered out of the blood depend on the size, electrical charges, protein binding, configuration and rigidity of the molecule. Small molecules with a molecular weight less than 7,000 Daltons (Da) are filtered through the membrane without restriction. These molecules include water and all ions such as sodium, potassium, chloride, phosphate, magnesium and calcium. Ions and other substances which are bound to proteins are not able to pass through the membrane. The passage of elliptical as opposed to round molecules easily pass through the filtration barrier, as will molecules which are less rigid but sufficiently flexible to negotiate through the membrane openings. Middle-sized molecules with a molecular weight of around 17,000Da, such as myoglobin released from the breakdown of red blood cells, do not easily filter through the membrane. Molecules which are much larger such as plasma proteins have molecular weights close to 70,000Da and under normal conditions are unable to pass through the filtration barrier. The electrical negative charge present in the filtration barrier restrict the movement of large molecules which have the same electrical charge, in comparison to the unrestricted passage of molecules with a positive or neutral charge. Since most proteins are positively charged the electrical repulsion which occurs also reinforces the restriction on the movement of plasma proteins through the filtration barrier. By allowing plasma proteins to be retained in the glomerular blood ensures osmotic pressure opposing hydrostatic pressure prevents the complete removal of plasma water in the capillary network (Marieb & Hoehn, 2007).

The mechanism of glomerular filtration is fundamental to preserving the body's internal environment and in the fulfilment of the major functions of the kidney. It forms the initial step necessary for the production of urine but relies on a constant GFR to ensure there is adequate solute and water removal. The GFR is approximately 125millilitre (ml) per minute (min) and close to 180 litres (L) of filtrate is produced over the duration of 24hr from an average total blood volume of 5L (Marieb & Hoehn, 2007).The large volume of filtrate which is generated ensures that the efficient filtration of plasma occurs so long as the permeability of the glomerular membrane remains intact and the volume of filtration is maintained at a constant rate. Only one to two L of urine

is produced per day leaving about 99% of filtrate to be reabsorbed back into the bloodstream. The final composition of glomerular filtrate has the same concentration of sodium, chloride, creatinine, urea, uric acid and phosphate as found in plasma, but on leaving the Bowman's capsule the solution is normally protein-free (Holechek, 2003a).

Tubular Reabsorption and Secretion

The nephron consists of specific tubular segments that extend from the Bowman's capsule which reabsorb or secrete substances as the glomerular filtrate passes along the tubular system (Chmielewski, 2003). The composition of the filtrate on leaving the glomerulus closely resembles plasma except for the almost complete absence of proteins in the solution. Due to the large volume of plasma which is initially filtered through the glomerulus there is rapid clearance of metabolic waste products, but in order to maintain a normal internal environment the majority of filtrate is required to be recycled back into the bloodstream. The composition and volume of filtrate undergoes considerable changes by the reabsorption and secretion at different segments of the tubular system.

The requirement of the nephron to return the majority of plasma filtered through the glomerulus is accomplished within the tubular system according to the specific properties of individual tubular segments (Chmielewski, 2003). The tubular system as shown in Figure 1.1 is divided into four segments with each tubule division consisting of a single cell wall. Individual divisions of the tubular wall incorporate semi-permeable membranes which have specific properties that alter the composition of the tubular fluid.

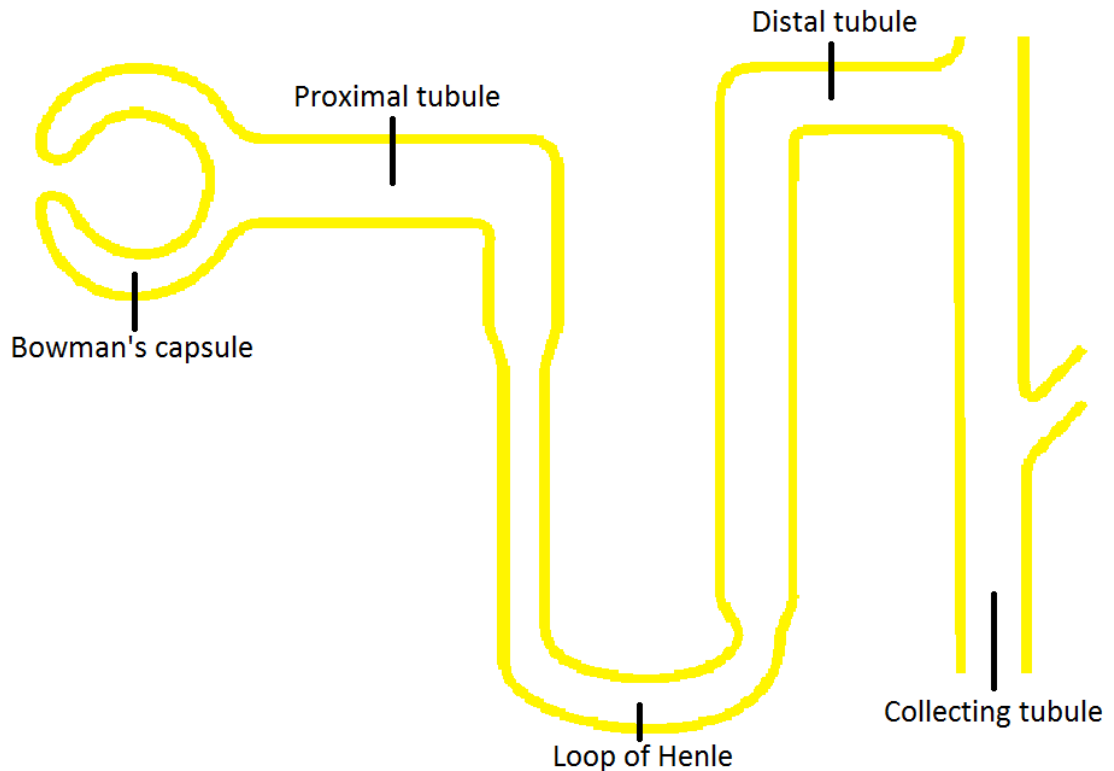

Figure 1.1. An illustration of the Nephron showing the four segments of the tubular system

Proximal tubule.

On first reaching the tubular system the proximal tubule is responsible for 65% reabsorption of water and sodium initially present in the glomerular filtrate (Chmielewski, 2003). Most substances are reabsorbed at this segment including 100% of glucose and amino acids, 90% of filtered bicarbonate, 75% of filtered phosphate, 60% of filtered calcium, 50% of filtered chloride and potassium, 50% of filtered urea, and approximately 30% of filtered magnesium. Secretion of endogenous and exogenous substances into the tubular fluid also occurs in the proximal tubule. The osmolarity of the tubular fluid virtually remains unchanged from plasma (iso-osmotic) due to the large reabsorption capacity of the proximal tubule matched by the secretion of metabolic waste products (Marieb & Hoehn, 2007).

Loop of Henle.

The descending limb of the loop of Henle is highly permeable to water but impermeable to the majority of solutes contained in the segment thereby causing the tubular fluid to become hyper-osmotic (Chmielewski, 2003). On reaching the thin

section of the ascending limb the action is reversed with the tubule cell wall being virtually impermeable to water present in the tubular fluid whilst permeable to the passage of sodium, chloride and urea. The thick portion of the ascending limb forms the remaining part of the loop of Henle. Water is again unable to pass through the tubule wall and due to the reabsorption of other substances such as potassium, bicarbonate, magnesium and calcium the tubular fluid at this point becomes hypo-osmotic (Chmielewski, 2003).

Distal tubule.

The early distal tubule continues the reabsorption of solutes such as sodium, chloride, bicarbonate, potassium, calcium and magnesium. Since the tubule wall remains impermeable to water the hypo-osmotic nature of the tubular fluid is unchanged (Chmielewski, 2003). In the late distal tubule the reabsorption of water is variable with the degree of water permeability of the tubule cell wall influenced by the presence or absence of antidiuretic hormone (ADH). The hypo-osmotic nature of the tubular fluid will change according to levels of ADH and the volume of water which is reabsorbed back into the bloodstream.

Collecting tubule.

The 'fine-tuning' of tubular fluid is repeated in the collecting tubule with ADH continuing to be instrumental in determining the final volume of water which is retained in the body. Large quantities of water are able to be reabsorbed under the influence of sodium reabsorption and concentrate the tubular fluid to resemble the composition of urine. Substances which are excreted in the urine include creatinine, urea, uric acid and unwanted electrolytes such as sodium, potassium and phosphate (Guthrie & Yucha, 2004).

The movement of water and solutes involves various transport mechanisms at different segments of the tubular system. Solute movement may occur by diffusion according to chemical and/or electrical gradients until a concentration equilibrium is reached on either side of the tubule wall (Ludlow, 2003). The opportunity also exists for some movement of solutes by co-transport and counter-transport mechanisms (Candela & Yucha, 2004). In other examples of solute movement active transport which requires the expenditure of energy may be involved. Using energy sourced from adenosine triphosphate (ATP) active transport allows the movement of solutes against a concentration gradient (Yucha & Guthrie, 2003). The movement of water is a passive

process influenced by the osmotic gradient established on either side of the tubule wall and in the degree of permeability which allows the passage of fluid across the semi-permeable membrane (Candela & Yucha, 2004). Opposite to the process of reabsorption the secretion of substances out of the blood flowing through the peritubular capillaries also permits the movement of solutes in both the proximal and distal segments of the tubular system using both passive and active transport mechanisms (Chmielewski, 2003). Substances released as end products of metabolism such as creatinine and urea are secreted into the tubular fluid increasing the total amount already removed from the blood by glomerular filtration. Other substances secreted include hydrogen ions which are important for acid-base control (Yucha, 2004) and potassium in exchange for sodium (Ludlow, 2003). The process of secretion also allows exposure of unwanted substances such as foreign chemicals to be removed from the blood and excreted out of the body (Chmielewski, 2003).

Regulation of Water and Electrolytes

The regulation of water and electrolytes is necessary to maintain the extracellular environment within a narrow range of values the body requires in order for cells to function normally (Candela & Yucha, 2004). The kidneys engage a number of mechanisms which integrate signals from other body systems, primarily the cardiovascular, nervous and endocrine systems, to control extracellular fluid volume and osmolality. The regulation of total body sodium through reabsorption or excretion by the tubules simultaneously regulates extracellular fluid volume. Sodium is predominately an extracellular solute and when alterations occur in the total body concentration of sodium this is accompanied by a change in the osmolality of the extracellular fluid (Candela & Yucha, 2004). Consequently, the concentration of sodium in the extracellular fluid is the major determinant of extracellular fluid volume which causes a similar change to occur in the volume of plasma.

The ADH mechanism regulates the concentration of sodium and extracellular fluid volume by controlling the osmolality and amount of urine produced. Aldosterone is the major regulator of sodium excretion and according to the amount of sodium reabsorbed by the tubules influences the amount of water retained and the loss of other ions including potassium, phosphate and hydrogen (Candela & Yucha, 2004). According to the level of potassium present and the availability of angiotensin II in the body, aldosterone is secreted by the adrenal cortex in response to the release of ADH from the anterior pituitary gland. Angiotensin II is the primary stimulator in the release

of ADH and is produced as part of the sodium-regulating reflex mechanism referred to as the renin-angiotensin system. The presence of low sodium levels due to a decrease in plasma volume stimulates the release of renin from the intrarenal baroreceptors, the macula densa and the renal sympathetic nerves. Once discharged the release of renin causes the separation of angiotensin I from angiotensinogen. The actions of angiotensin I lie dormant in the lungs until activated into angiotensin II by the angiotensin converting enzyme. The presence of angiotensin II causes vasoconstriction and stimulates the release of aldosterone from the adrenal cortex. Aldosterone is circulated through the bloodstream to the distal and collecting tubules which stimulates increased reabsorption of sodium and water. The opposite effect occurs in the reflex mechanism when an increase in plasma volume is detected due to an increase in sodium levels. A fall in the amount of renin secreted moderate the production of aldosterone. The decrease in the conversion of angiotensin I to angiotensin II causes less aldosterone to be released in the circulation and stimulates increased secretion into the urine of sodium and water (Candela & Yucha, 2004).

Maintenance of Acid-Base Balance

The hydrogen ion concentration of a solution is represented by the pH value. The pH scale refers to the 'potential or power of hydrogen' as a method of describing the concentration of hydrogen ions (Cree & Rischmiller, 2001). Higher concentrations of hydrogen ions make a solution more acidic, whilst lower concentrations of hydrogen ions make the solution more alkaline. Only free hydrogen ions contribute to the measured pH influenced by other ions such as phosphate or bicarbonate referred to as bases which donate or release hydrogen ions (Yucha, 2004). The kidneys play an important role in the regulation of acids and bases to maintain plasma pH levels between 7.35 and 7.45. When plasma pH levels are outside the normal range of values the efficiency of physiological processes in the body begins to deteriorate and the kidneys work in partnership with the respiratory system to avoid the adverse consequences of acid-base disturbances. As blood passes through the lungs and gaseous exchange takes place, the level of carbon dioxide retained determines the amount of carbonic acid present in the plasma and influences the quantity of hydrogen ions produced. Alterations in the rate and depth of breathing can lower or increase pH levels but only deals with changes by maintaining the hydrogen carbonate equilibrium (Cree & Rischmiller, 2001). The kidneys on the other hand have the ability to selectively remove or return ions and substances regardless of the hydrogen carbonate equilibrium

exercising greater control than the respiratory system over the concentration of various acids and bases in the pH level of plasma. The mechanisms employed by the kidneys to maintain acid-base balance involve the excretion of hydrogen ions and adjustment in the amount of bicarbonate reabsorbed by the tubular system or the quantity of bicarbonate generated by non-bicarbonate buffers (Yucha, 2004).

As explained the kidney has an intrinsic role in the regulation of fluids and electrolytes, the maintenance of acid-base balance and the removal of metabolic waste products. In order to successfully replace or support renal function in the critically ill patient in response to AKI and the development of ARF any intervention must be able to effectively correct and stabilise the body's internal environment.

Definition and Classification of Acute Kidney Injury

Acute kidney injury is characterised by a sudden loss of renal function whereby the organ is unable to adequately excrete metabolic waste products, maintain fluid and electrolyte homeostasis and regulate acid-base balance (Hilton, 2006; Lameire, Biesen, & Vanholder, 2005; Singri, Ahya, & Levin, 2003). Although there is consensus regarding the qualitative definition of AKI no consensus has so far been reached regarding the biochemical quantification of a decline in renal function. Quantitative definitions of AKI are based on verifiable clinical measurements routinely undertaken which reflect some of the physiological functions of the kidney in the production of urine and in the clearance of urea and creatinine from nitrogen metabolism. The development of oliguria or anuria despite adequate intravascular volume has been used by investigators along with an increase in the concentration of serum creatinine (SCr) in a number of clinical trials (Bellomo, Champman, Finfer, Hickling, & Myburgh, 2000; Bernard et al., 2001; Jochimsen, Schafer, Maurer, & Distler, 1990; B. Manns et al., 2003; Rangel-Frausto et al., 1995). Although the various quantitative definitions in published studies differ in their interpretation as to when organ dysfunction has occurred most identify a decline in urine output $< 0.5\text{ml per kilogram (kg)}$ and specify a range of SCr laboratory increases $> 150\text{ micromoles }(\mu\text{mol})\text{ per L}$ over several days or sudden rises $> 80\mu\text{mol per L}$ within 24hr as criterion of AKI.

The clearance of creatinine over 24hr to estimate GFR is a common laboratory measurement used to define AKI, but is associated with several limitations when used to determine the degree of renal damage sustained (Lameire, et al., 2005). Alteration in SCr concentration is not only influenced by the GFR but will also depend on the

production of creatinine, the volume of creatinine distributed throughout the body, and how creatinine is measured. The reporting of creatinine clearance is also problematic as measurements are insensitive to small changes in GFR either as an indicator of a decline or as a marker of recovery in renal function. Despite the limitations as a marker of renal function creatinine clearance in the definition of AKI remains a useful measurement.

According to the quantitative definition used to define AKI differences in the concentration of SCr add to the difficulties associated with the measurement of creatinine clearance. As a result of variations in the concentration of SCr used to determine loss of renal function inconsistencies can occur when the incidence and impact on patient outcomes of AKI are compared in the literature. The absence of an agreed-upon quantitative definition and the lack of a uniform classification system in the degree of injury sustained, influence when patients are enrolled and the endpoints used in studies designed to evaluate practices adopted in the management of AKI. So far the use of different quantitative definitions in published studies have made it difficult to undertake large prospective multi-centre investigations which are required to effectively identify patients at risk of AKI, develop strategies for prevention and treatment or, monitor expenditure of health resources (Uchino, 2006).

As shown in Figure 1.2 the risk injury failure loss end-stage (RIFLE) kidney disease classification system has been developed by the Acute Dialysis Quality Initiative (ADQI) group in an effort to reach a consensus on a quantitative definition of AKI according to the severity of renal insufficiency (Bellomo, Ronco, Kellum, Mehta, & Palevsky, 2004). The condition is classified into three severity categories according to the degree of risk, injury and failure. Classification of the severity in each category is met either through changes in SCr or urine output or both. The other two clinical categories measure outcome according to the duration in loss of renal function and the development of end-stage renal disease (ESRD). The degree of sensitivity to injury increases with milder forms of renal failure but the detection of renal dysfunction less specific, whereas specificity increases with moderate to severe renal dysfunction but is not as sensitive in the detection of increased trauma to renal function. Although the measurement of urine output and the monitoring of SCr levels identify changes in kidney function, both markers do not accurately reflect the extent of injury which has occurred to the kidneys. Several urinary and serum markers have instead been identified and investigated as possible indicators of renal injury before the presence of a decline in kidney function (Parikh & Devarajan, 2008). The use of injury rather than functional

markers offers the potential for the diagnosis of AKI to be identified earlier and reduce the delay of treatment designed to prevent the development of renal failure.

The validity of the RIFLE classification system as a proposed standardised quantitative definition for AKI has been evaluated in several studies. The ability of RIFLE to predict the mortality of hospitalised patients was tested in a large retrospective single-centre study (Uchino, Bellomo, Goldsmith, Bates, & Ronco, 2006). The authors reported there was an almost linear increase in the predictability of hospital mortality when patients were retrospectively classified according to the RIFLE severity category. A similar relationship between the RIFLE criteria and in the prediction of patient outcomes has been corroborated with other examples of retrospective analyses in the validation of the classification system. After retrospective comparisons of survival were made in a large cohort of patients admitted to ICU the severity of the RIFLE categories was shown to correlate with an increase in mortality (Hoste et al., 2006), and in another study the retrospective use of the RIFLE criteria was demonstrated to augment the prediction of outcome in critically ill patients when applied to established illness severity scores such as the acute physiology and chronic health evaluation (APACHE) II score (Abosaif, Tolba, Heap, Russell, & Nahas, 2005). The RIFLE classification system has also been shown to be a reliable predictor of patient survival in a number of prospective studies. The application of the RIFLE criteria was shown to

	Glomerulus Filtration Rate (GFR) Criteria	Urine Output (UO) Criteria	
Risk	Serum creatinine (SCr) elevated 1.5 times Or GFR decrease > 25%	UO < 0.5ml/kg/hr for 6hr	High Sensitivity
Injury	SCr elevated 2.0 times Or GFR decrease > 50%	UO < 0.5ml/kg/hr for 12hr	
Failure	SCr elevated 3.0 times GFR decrease 75% Or SCr 350µmol/l after an initial rise > 44µmol/l	UO < 0.3ml/kg/hr for 24hrs Or anuric for 12hr	
Loss	Persistent Acute Renal Failure with complete loss of renal function > 4 weeks.		
End-stage renal disease (ESRD)	ESRD > 3 months		

Figure 1.2. The RIFLE classification system (Bellomo, et al., 2004)

consistently identify increased mortality in patients who had undergone cardiac surgery when the procedure was associated with the incidence of postoperative renal dysfunction (Kuitunen, Vento, Suojaranta-Ylinen, & Pettila, 2006). The authors demonstrated the RIFLE classification system was an accurate predictor of 90 day mortality when measured against increases in SCr concentration levels and estimated

changes to GFR. The use of the RIFLE criteria was also shown to be a reliable prognostic tool in another prospective study for predicting the survival of patients who, based on biochemical abnormalities, were treated with CRRT (Bell et al., 2005). The authors observed 30 day mortality in patients with a severe RIFLE category (RIFLE-F and RIFLE-L) was significantly higher (> 50%) compared with those patients whose RIFLE category was less severe (RIFLE-R and RIFLE-I) (< 25%).

A number of refinements have been suggested by the Acute Kidney Injury Network (AKIN) in recognition of several important shortcomings of the RIFLE criteria (Mehta et al., 2007). One aspect not addressed by the RIFLE criteria is the lack of sensitivity related to SCr levels from baseline measurements. The proposed AKIN criteria introduces several stages which measure changes in SCr levels over 48hr with the intention to reflect more accurately the degree of renal impairment sustained. Despite the perception of increased sensitivity by staging the measurement of SCr levels misclassification of AKI was observed by Joannidis and associates (Joannidis et al., 2009) to have arisen more frequently using AKIN criteria when compared with assessment undertaken using RIFLE. The subsequent validation of the RIFLE criteria as a predictor of patient outcomes has led to wide acceptance of the definition and classification system for AKI. The shift of terminology away from ARF in favour of AKI using RIFLE to define and classify the changes in renal function has been reflected in the literature (Bagshaw et al., 2007). An upsurge in the use of a standard definition may see the RIFLE criterion adopted as a diagnostic reference point when investigations are undertaken to develop strategies for the prevention or management of AKI.

Causes of Acute Kidney Injury

The causes of AKI have traditionally been divided into three categories according to the location of injury sustained by the kidneys either the result of a reduction in glomerular perfusion (prerenal), the onset of intrinsic renal diseases (intrarenal), or the obstruction of the urinary tract (postrenal) (Lameire, et al., 2005). An important distinction can be made when comparing intrarenal failure with prerenal or postrenal failure. Once the causes of prerenal or postrenal failure are corrected the recovery from injury is usually rapid and there is often no residual loss of kidney function. This differs from intrarenal failure since recovery may be prolonged and injury to the kidney associated with permanent structural damage and the possibility of renal insufficiency.

Prerenal Injury

Prerenal injury is caused when there is a reduction in the supply of blood leading to hypoperfusion of the kidneys. The arteriolar autoregulation mechanism is unable to compensate for changes in perfusion pressure and there is a decrease in the GFR (Lameire, 2005). A variety of conditions can result in prerenal failure including loss of intravascular volume, reduced cardiac output, obstruction of blood flow by dissected aortic aneurysm, or a substantial decrease in vascular resistance due to peripheral vasodilation. Although a certain level of interpretation is required according to the individual's age and size when determining an acceptable urinary output, the volume of urine normally produced by the kidneys is between 0.5 and 2ml per kg of body weight per hr (Perkins & Kisiel, 2005). Implementation of supportive measures such as intravascular fluid expansion and the use of vasopressor agents can reverse the effects of hypoperfusion and restore normal kidney function in the excretion of urine.

Intrarenal Injury

Intrarenal injury is caused when damage to the kidneys has led to structural changes to the nephron involving the glomeruli, renal tubules, blood vessels and interstitium (Lameire, 2005). This is in response to a prolonged loss of renal perfusion due to inadequate intravascular volume, adverse effects of nephrotoxic agents or mechanisms associated with the inflammatory process.

Postrenal Injury

Postrenal injury refers to an obstruction of the urinary tract which prevents the flow and emptying of urine from the kidneys (Lameire, et al., 2005). The blockage can be due to renal calculi within the collecting tubules, compression of the ureter by prostate enlargement or external masses obstructing the bladder outlet. Treatment is directed at removing the obstruction and once urinary flow is restored normal kidney function usually returns.

The most common cause of AKI in the critically ill patient is as the result of intrarenal injury due to Acute Tubular Necrosis (ATN) (Lameire, 2005). The development of ATN can either originate as the result of an ischaemic event or after exposure to nephrotoxic substances. A combination of both ischaemia and nephrotoxicity can also lead to ATN which is of a mixed etiology.

Pathophysiology of Acute Tubular Necrosis

The critically ill patient is often exposed to the effects of hypoperfusion and is considered a precursor to ischaemic intrarenal injury and the development of ATN. Controversy surrounds the use of the term ATN to describe the pathophysiology of AKI since the presence of necrotic tubular cells has not always been a defining feature observed during histological examination. Evidence from renal biopsies undertaken on ischaemic injury have shown the presence of only limited necrosis despite the existence of marked functional impairment (Lameire, 2005). The death of renal tubules is suspected to instead occur by apoptosis a form of cell death where the damaged cell undergoes a cascade of intracellular changes. Once damaged the cell is broken down and cellular debris removed by phagocytosis. The process is often underestimated due to changes which are difficult to detect in histology tissue samples (Bonventre & Weinberg, 2003). Consequently, the physiological derangement caused by ATN is not necessarily reflected by a profound alteration in renal tubule pathology.

The development of ATN due to ischaemic intrarenal injury is associated with an interruption in the blood supply to the kidneys. Approximately 20 to 25% of cardiac output is normally distributed to the kidneys delivering a blood flow rate of 1,000-1,200ml per min (Holechek, 2003a). The large supply of blood exceeds the metabolic and oxygen requirements of the kidneys in order to facilitate the efficient clearance of metabolic waste products and maintain internal biochemical stability. A reduction in blood flow can be caused by hypovolaemia, but may go unrecognised when it is not associated with a dramatic drop in blood pressure. The intrarenal response to hypotension relies on the autoregulation system to detect a reduction in perfusion pressure. As the result of a drop in arterial blood pressure the afferent and efferent arterioles which enter and leave the glomerulus vasoconstrict or vasodilate under the influence of the myogenic and tubuloglomerular feedback (TGF) mechanisms (Marieb & Hoehn, 2007). The myogenic mechanism senses changes in vascular tone and, as part of the juxtaglomerular apparatus the TGF mechanism recognises alterations in the composition of tubular fluid at the macular densa. A natural tendency for vascular smooth muscle to contract when stretched by increased blood flow causes the efferent arteriole to vasoconstrict following vasodilation of the afferent arteriole. The macula densa cells of the juxtaglomerular apparatus respond to the concentration of sodium according to the GFR and the amount of sodium reabsorption which occurs in the ascending limb of the loop of Henle. A decrease in the rate of filtrate reaching the distal

tubule exposes the macula densa cells to low levels of sodium causing juxtaglomerular cells in the smooth muscle walls of the afferent arteriole to vasodilate. Significant energy-dependent solute transport may occur in the outer medulla region of the kidney with the ascending portion of the loop of Henle requiring the greatest uptake of oxygen to release energy for the active transport of sodium. The supply of oxygen through this section of the loop of Henle is very sensitive to changes in perfusion pressure should a systolic blood pressure drop below 90 millimetres of mercury (mmHg) (Abuelo, 2007).

A reduction in the capacity of the TGF mechanism to compensate for changes in perfusion pressure will stimulate activation of the renin-angiotensin mechanism (Marieb & Hoehn, 2007). Juxtaglomerular cells located in the efferent arteriole are stimulated to release renin following the detection of a drop in glomerular hydrostatic pressure. Once present in the circulation the enzyme converts the plasma protein angiotensinogen to angiotensin I. Circulation of angiotensin I to the lungs exposes the protein to the angiotensin converting enzyme (ACE) found in the pulmonary capillary network. Angiotensin I is converted into Angiotensin II which acts on the smooth muscles of efferent arterioles to vasoconstrict and increase vascular resistance. The decrease in perfusion pressure is able to be temporarily alleviated by adrenergic and angiotensin II activity combined with the release of aldosterone to increase tubular reabsorption of sodium and water. A delay in the restoration of blood flow will place extra demand for oxygen in the loop of Henle and provoke the development of ischaemia due to the effects of vasoconstriction and increased sodium and water absorption. Although the loss of intravascular volume has been suspended following the onset of physiological oliguria, the increase energy requirements for active transport in the ascending loop of Henle deplete tubular stores of ATP (Lameire, 2005). The severity of ATP depletion is halted after the increased release of adenosine causes more vasoconstriction and the tubular workload of the ascending loop of Henle is momentarily decreased after a reduction in the GFR slows down solute delivery. Eventually the normal physiological responses to changes in blood flow and perfusion pressure are unable to successfully protect the kidney from injury. Once the TGF and the renin-angiotensin mechanisms are exhausted ischaemia to the medullary region of the kidney will result in death of tubular cells and a pathophysiological decline in renal function. The development of organ failure is no longer considered a prerenal injury but the result of ischaemic intrarenal injury as a consequence of inadequate perfusion of the kidneys.

The other causes of ATN occur after exposure to endo- and exo toxic substances (Evenepoel, 2004). Endothelial cells of the renal tubules are either directly injured by the toxin alone, or indirectly damaged when mechanisms which normally protect renal blood flow such as the autoregulation system succumb to a toxic insult. Myoglobin is an endotoxin which can cause the development of ATN when released into the circulation during rhabdomyolysis (Evenepoel, 2004). The formation of casts leading to tubular obstruction and the death of endothelial cells is thought to occur when myoglobin is filtered through the glomeruli and allowed to reach the renal tubules. Haemoglobin is another example of an endotoxic substance which can increase the risk of ATN when there is intravascular haemolysis and evidence of haemoglobinuria (Evenepoel, 2004). Among the exotoxic substances which can cause chemical-induced ATN many are associated with contrast media used for diagnostic procedures and in the medications required to treat the critically ill patient. Aminoglycoside antibiotics are particularly nephrotoxic if serum levels are not carefully monitored and necessary adjustments made in the treatment of severe infection (R. John & Herzenberg, 2009). Similarly, radiographic contrast agents produce harmful effects and impair renal function when high doses of radio-contrast dye are delivered and the patient is not sufficiently hydrated (Tumlin et al., 2006).

The development of ATN can occur as the result of sepsis representing a mixed injury caused by ischaemia and nephrotoxicity when patients are exposed to severe infection. A major cause of hypoperfusion leading to tubular ischaemia during septic shock is the result of injury sustained by systemic arterial vasodilation following the release of inflammatory mediators (Wan, Bellomo, Giantomasso, & Ronco, 2003). In response to a decrease in systemic vascular resistance the fall in blood pressure changes the GFR by altering the relationship between the afferent and efferent arterioles. Although renal blood flow will be increased due to widespread vasodilation the pressure within the glomerulus can drop as the efferent arteriole dilates even more than the afferent arteriole. As a consequence of lost perfusion pressure the delivery of oxygen to the renal tubules is reduced despite an adequate supply of blood to the medullary region of the kidney. Activation of the coagulation pathway due to the inflammatory response also causes the release of microthrombi and the risk of ischaemia due to intravascular thrombosis occurring within the infrastructure of the nephron (Wan, et al., 2003). The other mechanism of injury which is caused by severe infection arises when ATN is the result of exposure to harmful bacteria. Once infiltration of the organism has occurred

interaction with inflammatory mediators allow bacterial substances to enter the blood stream and pass through the renal vasculature leading to nephrotoxic tubular injury (Wan, et al., 2003).

The pathophysiology of ischaemic or nephrotoxic ATN results in damage to the renal tubules and surrounding vasculature. A retrospective analysis of patients with ischaemic (46%) and mixed ATN (55%) observed a higher incidence of multiple organ dysfunction (MOD) after comparisons were made with the frequency of dysfunction reported when AKI was isolated to nephrotoxic ATN (7%, P-value < 0.0001) (Santos et al., 2006). Since the causes of ATN in the critically ill patient may have a number of etiologies the combined effects of ischaemia and nephrotoxicity increase the risk of damage to the kidneys and decrease the chances of patient survival due to the adverse effects of renal insufficiency. The extent of injury sustained is nevertheless able to be offset by the capacity of the epithelial cells to repair structural and biochemical processes associated with restoring the integrity of the tubular system and re-establishing renal function. Once reperfusion of the tubular system has occurred there is a proliferation of viable epithelial cells with the incorporation of growth factors which leads to the regeneration of normal tubular epithelium (Thadhani, Pascual, & Bonventre, 1996). The prevention of repeated exposure to renal hypoperfusion will allow the process of regeneration to occur early, and limit the degree of permanent damage which is sustained by the kidney affecting the long-term viability of renal function.

Epidemiology of Acute Kidney Injury

The epidemiology of AKI is not widely understood due to regional disparities in the definition and reporting of the condition. Studies which have investigated the incidence and impact of AKI on hospitalised patients have been confounded by the absence of standardised criteria to describe loss of renal function, the lack of adjustment for differences in the severity of illness, and under representation of existing comorbidities. Despite these shortcomings examples exist in the literature of single and multicentre studies which describe the epidemiology of AKI. The information gained from each study can provide insight on the significance of AKI as a factor influencing the recovery of the critically ill patient.

Over the last decade the incidence of hospital-acquired AKI has increased. The results of a follow up study based on the original investigation undertaken a decade earlier showed a reported rise of cases from 4.9% (Hou, Bushinsky, Wish, Cohen, &

Harrington, 1983) to 7.2% (Nash, et al., 2002) after each single centre study used the same defining criteria to determine the presence of ARF. During a nine month multicentre epidemiology investigation of admissions to 13 tertiary hospitals the development of AKI was prospectively observed by the Madrid Acute Renal Failure Study Group (Liano & Pascual, 1996). The overall incidence of hospital-acquired AKI covering a population of 4.2 million people was reported to be 209 cases per million. Out of the 748 episodes identified by the authors 45% of cases were caused by intrarenal failure, 21% of cases as a result of prerenal failure, and 10% of cases due to postrenal failure. The mortality rate of patients with AKI was observed by Liano and Pascual (1996) to be much higher (45%) when compared with other patients admitted to hospital who did not acquire the condition (5.4%). Attempts to investigate the development of AKI among the critically ill population have reported a greater incidence of cases when compared with those observed in other hospitalised patients outside of ICU. Over a period of 15 months the BEST kidney study investigated the incidence and causes of AKI in the critically ill patient (Uchino, et al., 2005). Across each of the 54 medical centres in 23 countries which participated in the study the prevalence of AKI in 29,269 patients ranged between 1.4% and 25.9%. Out of those patients diagnosed with AKI the authors observed 47.5% were associated with sepsis, 34% after patients had undergone major surgery, 27% of cases related to cardiogenic shock, hypovolaemia had occurred in 26% of patients and 19% as the result of exposure to nephrotoxic drugs. Irrespective of the causes which had led to the development of AKI the authors reported over half went on to require RRT. As a consequence of AKI the BEST study reported a mortality rate of between 50.5% and 76.8% (Uchino, et al., 2005). Among patients with sepsis as the cause of AKI the mortality rate was significantly higher when compared with nonseptic patients (70.2% versus 51.8%, P-value < 0.001). Based on the findings of BEST the onset of sepsis was the most common contributing factor in the development of AKI and the condition most likely to decrease the chances of survival in the critically ill patient. Out of those patients who survived and were discharged home 13.8% were dependent on some form of RRT.

The characteristics of hospitalised patients have changed over several years as a consequence of improved medical technology. Patients now admitted to the ICU who may not have otherwise survived are handicapped by complex medical problems with pre-existing chronic illnesses that weaken their chances of survival. More recent observational studies which have been undertaken suggest critically ill patients who

develop AKI occur in older patients, who have more existing co-morbidities, are more likely to be septic due to severe infection and have greater severity of illness and organ dysfunction (Bagshaw et al., 2005; de Mendonca et al., 2000; Mehta et al., 2004). The findings of a systematic review on the literature regarding the mortality rate of patients with severe ARF suggested the survival of patients had not improved and was virtually the same over several decades despite advances made in RRT and other forms of supportive interventions (Ympa, Sakr, Reinhart, & Vincent, 2005). This may not be a correct interpretation on the review of studies investigating the incidence of deaths related to the development of AKI. Caution should be exercised when undertaking systematic reviews on previously reported mortality of hospitalised patients when they are confounded by different definitions of AKI, variations in severity of illness, unknown number of patient co-morbidities, and various management practices over different time periods (Bellomo, 2006). Other attempts at investigating possible changes in the mortality of patients with AKI are based instead on studies using databases established over several years which are more representative of population sub-groups and use similar coding systems to determine in-hospital differences and changes to patient mortality. A significant fall in the mortality rate of hospitalised patients with AKI was observed by Bagshaw and associates (2007) between 1996 to 2005 using the Australian New Zealand Intensive Care Society (ANZICS) Adult Patient Database (annual percentage change -3.4%, 95% confidence interval [CI], -4.7 to -2.12, P-value < 0.001). After similar adjustments were made for illness severity the stratified analysis of in-hospital mortality due to AKI between 1988 and 2002 was also previously reported to have declined in the United States (US) (40.4% versus 20.4%, P-value < 0.001) (Waikar, Curhan, Wald, McCarthy, & Chertow, 2006). The findings of the Australian study corroborates with the earlier findings of the US study where both investigations identified a significant decrease in mortality from AKI over the past decade. Despite the reported improvement in the survival of patients with AKI the mortality rate in the Australian study remained significantly higher when compared with the lower mortality observed in patients who did not sustain AKI during their stay in ICU (42.7% versus 13.4%, P-value < 0.0001) (Bagshaw, George, et al., 2007). The additional observations made by the authors of the Australian study suggest although the associated mortality with organ dysfunction has declined in recent years the development of AKI is nevertheless an independent factor which increases the risk of death for the critically ill patient.

Consequences of Acute Kidney Injury

The physiological consequences of AKI in the critically ill patient derive from the important role the kidneys normally play in the maintenance of water and electrolyte regulation, in the excretion of metabolic waste products and in the preservation of acid-base balance. A decline in renal function can influence the activity of other organ systems and jeopardise the ability to maintain normal body homeostasis which may culminate in the development of Multiple Organ Dysfunction (MOD). The adverse physiological complications of fluid volume overload, electrolyte disorders, retention of organic compounds and metabolic acidosis depend on the severity of renal insults which have occurred and the pre-existing functional status of the kidney.

Volume overload

The administration of intravenous fluid and liquid nutrition is often required in the management of the critically ill patient. This can lead to the accumulation of fluid as the result of AKI when there is deterioration in renal function and the development of oliguria. A direct correlation between fluid overload and mortality in critically ill patients was reported by Bouchard and associates (2009) in a prospective observational study. After adjustment was made by the authors regarding severity of illness a 10% rise in body weight above baseline measurements was associated with increased patient mortality due to excess fluid volume (mortality at 30 days, 37% versus 25%, P-value = 0.02; mortality at 60 days, 46% versus 32%, P-value = 0.006; on hospital discharge, 48% versus 35%, P-value = 0.01). Several reasons might explain why volume overload due to AKI can reduce survival in the critically ill patient or worsen the severity of injury sustained. The accumulation of fluid in lung tissue places the patient at risk of hypoxia when gas exchange within the alveoli is reduced and the requirement for mechanical ventilation increases the potential for the respiratory tract to become a source of infection. A positive fluid balance was shown during an observational study to worsen the outcome of patients diagnosed with acute lung injury (ALI) when the resolution of excess fluid volume was delayed (survivors of ALI total cumulative negative fluid balance -3.0mLs standard deviation [SD] \pm 17.8 versus non-survivors of ALI total cumulative positive fluid balance 4.4mLs SD \pm 23.6, P-value < 0.001) (Sakr et al., 2005). The instigation of positive-pressure ventilation increases intrathoracic pressure and due to a decrease in cardiac output alters renal blood flow on kidney function already compromised by the original injury (Pannu & Mehta, 2004). In the presence of existing AKI patients may also have accumulation of extracellular fluid due

to the effects of cardiac failure or altered protein capillary permeability as the result of septic shock. The impact of increased transcapillary hydrostatic pressure on an encapsulated organ like the kidney when coupled with decreased transcapillary oncotic pressure, may eventually lead to the presence of fluid in the interstium causing the elevation of venous pressure to interrupt the distribution of renal blood flow (Prowle, Echeverri, Ligabo, Ronco, & Bellomo, 2010). As a result of interstitial oedema within the infrastructure of the kidney oxygen delivery is impaired and can prolong the recovery of renal function. The resolution of excess fluid volume in the management of AKI is now recognised as being an important pathological factor which has the potential to lower patient mortality and reduce the severity of organ dysfunction (Cerda, Sheinfeld, & Ronco, 2010).

Electrolyte disorders

The development of electrolyte disorders as the result of AKI can induce a wide range of clinical disorders by interrupting the important role electrolytes play in cellular metabolism and membrane potentials of muscle and nerve cells (Ahern-Gould & Stark, 1998). Hyponatraemia is a common feature of patients with renal insufficiency when oliguria causes the retention of water and the dilution of sodium ions within the extracellular fluid compartment (Adroque & Madias, 2000). The presence of hyponatremia leads to swelling of the cells due to an osmotic gradient differential between the intracellular and extracellular fluid compartments. Changes in the volume of fluid present within body cells interrupt the normal functioning of the central nervous system and may lead to the development of seizure activity. Hyperkalaemia is a similar condition which is again associated with AKI when a decrease in the renal excretion of potassium causes an elevation of serum potassium levels (Nyirenda, Tang, Padfield, & Seckl, 2009). An elevation of potassium will also occur when the transfer of potassium from the intracellular to the extracellular fluid compartment is increased due to alterations in acid-base balance caused by the retention of inorganic acids, or after potassium is released into the bloodstream following extensive tissue damage. The presence of hyperkalaemia can be a life-threatening condition as it can lead to changes in cardiac electroconduction and the possible development of ventricular arrhythmias (Mattu, Brady, & Robinson, 2000). Similar disturbances with normal physiological activities of the body can arise when the homeostasis of other electrolytes is affected by renal insufficiency. Chloride is the most abundant extracellular anion which can accumulate if not excreted in sufficient quantities to reduce the strong ion differential

necessary for maintaining acid-base balance (Thomson & Macnab, 2009). Magnesium is another example of an electrolyte excreted by the kidneys where failure to remove sufficient quantities can lead to respiratory muscle weakness and atrioventricular blocks due to abnormal polarisation of cardiac muscle. Calcium absorption will also be reduced when there is loss of renal function and may interrupt the excretion of phosphate when the recovery of the kidneys is delayed causing calcium and phosphate to be deposited in tissues leading to increased nerve stimulation and muscle spasm (Thomson & Macnab, 2009).

Retention of organic compounds

Urea is an organic solute normally found in the bloodstream following the metabolism of protein and along with SCr levels the Blood Urea Nitrogen (BUN) level is used as a marker to represent the removal of nitrogenous waste products and other toxins which are normally excreted by the kidneys (van Holder & de Smet, 1999). In the presence of AKI a variety of biochemical and physiological changes occur in response to the retention of urea and other organic compounds including platelet dysfunction and neurological deterioration, particularly if urea accumulation is rapid. The adverse consequences of an uraemic syndrome due to renal insufficiency is well documented in patients who have ESRD (Alper Jr., Shenava, & Young, 2010). The syndrome can also occur as the result of AKI but rather than a gradual manifestation over several years the loss of kidney function is rapid with uraemia developing over days to weeks.

The impact on patient outcome of urea accumulation in ARF has not been well defined in the critically ill population. On admission to ICU a significant difference in patient mortality was observed showing a worse outcome for patients who had sustained AKI when compared with those patients who had existing ESRD (23% versus 11%, P-value < 0.001) (Clermont et al., 2002). The observations made by the authors suggest the increased mortality associated with AKI was influenced by different factors and not caused solely by the accumulation of urea, but the loss of kidney function was overall a predictor of reduced survival since patients with ESRD had a mortality rate twice that of patients who showed no signs of renal insufficiency (5%). Although the impact of uraemia in AKI is not well understood investigations undertaken by several other authors have shown the survival of patients is improved when the intensity of solute removal reduces the concentration of urea present in the bloodstream during haemodialysis or haemofiltration (Ronco, et al., 2000; Saudan et al., 2006; Schiffil, Lang, & Fischer, 2002).

Metabolic acidosis

A common manifestation of AKI in critically ill patients is the development of a metabolic acidosis caused by the accumulation of organic acids and the loss of alkaline substances (Charles & Heilman, 2005). The acid-base disorder is the result of deterioration in the capacity of the kidneys to excrete hydrogen ions coupled with a reduction in the production or reabsorption of bicarbonate. The magnitude of the metabolic acidosis is also influenced by non-renal sources according to the nature of illness sustained by the patient (Gauthier & Szerlip, 2002). Examples of non-renal sources include anaerobic metabolism and the build-up of lactic acid, or an elevated anion-gap due to diabetic ketoacidosis, or as the result of ingesting harmful substances causing the formation of acid metabolites. Calculation of the anion gap between positively charged cations and negatively charged anions is used to determine the severity of the metabolic acidosis. A drop in the serum concentration of bicarbonate in the absence of gastrointestinal losses suggests a decline in kidney function with the accumulation of organic acids not matched by a rise in the concentration of chloride (Gauthier & Szerlip, 2002). The anion gap can be used to determine the severity of the metabolic acidosis so long as the difference is adjusted in patients who are hypoalbuminaemic, otherwise the negatively charged protein can disguise the acid-base disorder due to the reduced concentration of albumin. The early recognition of a decline in kidney function is necessary to prevent a metabolic acidosis from adversely impacting on the function of other organs (Charles & Heilman, 2005). A decrease in plasma pH for example can result in pulmonary vasoconstriction and contribute to right ventricular failure due to higher pulmonary vascular pressures increasing the workload of the heart. The extra burden imposed on the lungs to increase ventilation and compensate for a worsening metabolic acidosis is another example of how organ dysfunction may be observed when a decrease in plasma pH can lead to respiratory muscle fatigue.

Protective Strategies

The instigation of therapeutic strategies in response to the physiological consequences of AKI is directed at the preservation of existing renal function and in the prevention of irreversible damage to the kidneys. A number of interventions have been suggested by Ronco and Bellomo (2003) as possible strategies to protect the critically ill patient from AKI. The proposed strategies include interventions which benefit most organ systems; maximise blood flow to the kidneys by the maintenance of cardiac

output, the expansion of intravascular fluid volume and in the stabilisation of organ perfusion pressure. Based on the aforementioned interventions other examples of protective strategies incorporate the use of pharmacologic agents to support kidney function. For example some diuretic agents have been shown to be useful in maintaining urinary output and hence fluid balance (Bagshaw, Delaney, Haase, Ghali, & Bellomo, 2007), whilst the use of low-dose dopamine to improve renal blood flow is not recommended (Friedrich, Adhikari, Herridge, & Beyene, 2005), whereas the use of acetylcysteine may be of benefit when combined with intravenous fluids in patients exposed to radiographic contrast dyes (Marthaler & Keresztes, 2004).

Cardiac output

The maintenance of cardiac output (CO) is important in order to sustain adequate blood flow and perfusion of body tissues. At what point diminished CO results in renal dysfunction is nevertheless unclear from the literature. A number of studies have investigated the use of various measures which support CO in patients at risk of AKI and the failure of other organs (Annane et al., 2007; Finfer et al., 2004; Waksman, Weiss, Gotsman, & Hasin, 1993). The array of interventions can range from the administration of intravenous fluids and the use of vasopressor agents to a more invasive approach of surgery and the insertion of mechanical assist devices. A prospective multi-centre study of critically ill patients found those who were randomised to receive goal-directed haemodynamic therapy which increased cardiac index to supranormal levels ($> 4.5\text{L per min}$), or was directed at maintaining normal mixed venous oxygen (SvO_2) at $\geq 70\%$, had no significant effect on reducing mortality up to the time of discharge from the ICU when comparisons were made with a normal cardiac index control group (supra-normal cardiac index group 48.6% versus SvO_2 group 52.1% versus normal cardiac index control group 48.4%, $P\text{-value} = 0.638$), and the absence of any difference in survival did not change when patient outcomes were again reviewed after six months (supra-normal cardiac index group 61.7% versus SvO_2 group 63.8% versus normal cardiac index control group 62.3%, $P\text{-value} = 0.875$) (Gattinoni et al., 1995). Out of those who had survived the authors also reported the prevalence of renal dysfunction did not differ significantly between the three study groups (urinary output mLs/hr during treatment normal cardiac index control group 110 $\text{SD}\pm 59$ versus SvO_2 group 105 $\text{SD}\pm 55$ versus supra-normal cardiac index group 88 $\text{SD}\pm 55$, $P\text{-value} = 0.139$). An important factor to note when considering the results observed during the study was a large proportion of patients assigned to the

supranormal cardiac index treatment group (44.9%) did not achieve the designated haemodynamic target. The extraordinary haemodynamic target may have been unrealistic and confounded the results obtained since compliance in reaching the ordinary haemodynamic target was greater in the other treatment groups (normal cardiac index control 94.3%, normal SvO₂ values 66.7%).

A different observation was made when goal-directed haemodynamic therapy was investigated during a prospective single-centre study involving patients diagnosed with early stages of severe sepsis before admission to ICU (Rivers et al., 2001). Patients who were randomised in the Emergency Department to receive standard haemodynamic therapy which did not specifically target SvO₂ levels had a significantly higher mortality rate at 28 days when compared with patients who had been assigned to receive goal-directed haemodynamic therapy which achieved SvO₂ levels $\geq 70\%$ (standard haemodynamic therapy 49.2% versus goal-directed haemodynamic therapy 33.3%, P-value = 0.01). The goal-directed group of patients were also observed by the authors to experience less organ dysfunction (standard haemodynamic therapy 6.4 SD \pm 4.0 versus goal-directed haemodynamic therapy 5.1 SD \pm 3.9, P-value < 0.001) and significantly lower APACHE II scores (standard haemodynamic therapy 15.9 SD \pm 6.4 versus goal-directed haemodynamic therapy 13.0 SD \pm 6.3, P-value > 0.001) after 72-hr hospitalisation. Although this study was not designed to specifically investigate the incidence of renal insufficiency the strategy of reducing tissue hypoxia would nevertheless have had a possible beneficial effect on preserving kidney function.

The maintenance of cardiac output by goal-directed haemodynamic therapy may avoid organ dysfunction including the preservation of renal function. This can be achieved by the monitoring of SvO₂ levels and the instigation of measures which support cardiac output to meet the demand for oxygen in the supply of blood to the body's organs.

Expansion of intravascular fluid volume

A lack of intravascular fluid volume caused by acute haemorrhage and increased capillary leakage are examples of conditions commonly associated with the critically ill patient. The development of renal injury occurs when compensatory mechanisms such as the renin-angiotensin system are overwhelmed and unable to prevent a decrease in blood flow to the kidneys. The loss of intravascular fluid volume which is not able to be

replaced causes the development of hypovolaemia and a reduction in blood supply to the kidneys (Ragaller, Theilen, & Koch, 2001).

The administration of fluid is used to safeguard the patient against the adverse effects of hypovolaemia, but there are no recommendations in regards to a specific intravascular fluid volume which is more protective of renal function. The restoration and maintenance of intravascular volume is a frequent activity undertaken by the critical care nurse. In many situations the administration of fluid will require the monitoring of Central Venous Pressure (CVP) to measure right ventricular intravascular volume. The task of fluid resuscitation is made more difficult to manage in patients when the risk of AKI is associated with other organ failures. A liberal approach to fluid administration (CVP 10-14mmHg) was shown in one randomised study of patients with ALI to increase the duration of mechanical ventilation when compared to patients who instead received a conservative fluid management strategy (CVP < 10mmHg) (Wiedemann et al., 2006). Absolute values of CVP recordings can be misleading in patients who are receiving positive-pressure ventilation with ‘artificially’ raised intrathoracic measurements masking the depletion of intravascular volume. Observations made by the critical care nurse of marked ‘swings’ in arterial pressure tracings along with physical inspection of the patient may instead provide a better indicator that intravascular fluid expansion is required (Murch, 2005). A fine balance is often required to achieve adequate replacement of intravascular volume sufficient to sustain renal function but avoid the risk of fluid overload should AKI develop.

The choice of whether to use crystalloid or colloid solutions for the replacement of intravascular fluid volume has been the cause of controversy when the effect on patient survival was analysed differently after studies investigating fluid resuscitation practices in the critically ill patient were reviewed (Choi, Yip, Quinonez, & Cook, 1999; Cochrane Injuries Group Albumin Reviewers, 1998). This prompted the ANZICS Clinical Trials Group to conduct a large, multi-centred, randomised, double-blinded trial to evaluate the effect of crystalloid versus colloid administration on mortality in the ICU (Finfer, et al., 2004). The authors of the Saline versus Albumin Fluid Evaluation (SAFE) study reported patient survival from all-cause mortality at 28 days was no different using 0.9% normal saline when compared with 4% albumin.

The practice of intravascular fluid expansion has been shown to protect the kidneys from possible injury caused when patients are exposed to radio-contrast agents

or affected by the development of rhabdomyolysis. The administration of intravenous fluids before and after diagnostic procedures (Bader et al., 2004) and the selection of isotonic rather than hypotonic hydration (Mueller et al., 2002) have demonstrated to be effective strategies in protecting the kidneys against the harmful effects of nephrotoxic substances present in radio-contrast agents. On the strength of observations made following the rescue of earthquake victims who had sustained crush injuries from collapsed masonry, early and vigorous fluid resuscitation in the management of traumatic rhabdomyolysis was shown to have a protective affect on maintaining kidney function (Gunal et al., 2004). The administration of extra volume reduces the development of hypovolaemia when damaged muscles become swollen and, as a consequence of muscular injury, expose the patient to the release of large quantities of myoglobin. The potentially harmful affects of myoglobin on kidney function is then minimized by using a mannitol-alkaline solution. Intravascular fluid expansion with a forced diuresis maximises renal excretion by flushing out debris following the breakdown of myoglobin. This reduces exposure of renal tissues to nephrotoxic substances and the possibility of tubular obstruction. The addition of sodium bicarbonate into the intravenous crystalloid infusion causes the alkalinisation of urine to protect the tubular system against further breakdown of myoglobin (Criddle, 2003).

Despite the absence of a Randomised Clinical Trial (RCT) clinical experience suggests the depletion of intravascular volume without fluid replacement increases the risk of AKI. There are no recommendations in regards to a specific intravascular fluid volume which is more protective in safeguarding the kidney against the effects of hypovolaemia, what evidence is available suggests that a fluid input sufficient to maintain urine output at least 0.5ml per kg in an adult will sustain kidney function, fluid in excess of this of this may impair other organ performance without enhancing survival. Intravascular fluid expansion is recommended for diagnostic procedures which require the administration of radio-contrast agents and in the management of rhabdomyolysis.

Renal perfusion pressure

A decrease in urinary output when combined with a fall in blood pressure can suggest a reduction has occurred in renal perfusion pressure. In humans the lowest threshold of renal autoregulation is estimated to be around 80mmHg before the mechanism is unable to compensate for a drop in systemic blood pressure and the GFR can no longer be maintained at normal levels (Bersten & Holt, 1995). Once the

autoregulatory mechanism is below this threshold any further drop in systemic blood pressure stimulates the release of endogenous vasoconstrictors but the effects of prolonged hypotension will eventually cause a reduction in renal blood flow to the glomeruli and in the perfusion of other tubular structures (Abuelo, 2007).

The management of hypotension is directed at targeting a mean arterial pressure (MAP) which is sufficient to perfuse the kidneys and in the perfusion of blood to other organs. International guidelines put forward by members of the Surviving Sepsis Campaign recommend a MAP of greater than 65mmHg is the minimum pressure required to reduce the incidence of organ dysfunction as the result of tissue hypoperfusion (Dellinger et al., 2008). When the autoregulatory capacity of the kidneys is unable to compensate for a drop in blood flow to the kidneys, fluid replacement should be initially used to optimise intravascular volume. In patients who continue to be hypotensive despite adequate hydration the use of vasoactive and inotropic agents may be necessary in order to achieve a higher MAP. The vasoactive agent commonly used for the management of persistent hypotension is Noradrenaline causing widespread vasoconstriction by the stimulation of α - adrenergic receptors (Bellomo, Wan, & May, 2008). In response to the vasoconstrictive effects of Noradrenaline the decline in MAP is interrupted and blood flow to the kidneys maintained by the restoration of the autoregulatory pressure threshold, but caution should be exercised in the administration of Noradrenaline to avoid excess vasoconstriction and organ hypoperfusion. Under situations of pronounced vasodilation as seen in patients with septic shock the use of Noradrenaline may assist in the return of normal vascular tone and as a result improve renal perfusion pressure. The findings of a RCT investigating the management of septic shock reported the use of Noradrenaline was associated with a significant improvement in the reversal of hypotension and restoration of urinary output when compared with patients who instead received high-dose Dopamine (C. Martin, Papazian, Perrin, Saux, & Gouin, 1993).

A number of recommendations regarding the maintenance of renal perfusion pressure can be made using knowledge on the physiological regulation of blood flow and on the clinical experience gained at the bedside in the management of hypotension. Despite the limited availability of evidence from extensive investigation the replacement of intravascular fluid to correct hypovolaemia should be administered before consideration is given to the commencement of vasopressor agents. The use of Noradrenaline to reduce vasodilation and loss of vascular resistance in patients with

septic shock can restore renal perfusion pressure which may have a protective effect on maintaining kidney function.

Pharmacologic Agents

A variety of pharmacologic agents for the prevention of AKI and in the management of established ARF are suggested to support existing renal function, minimise damage to the kidneys and promote the recovery of renal activity. The possibility of protecting the critically ill patient against the adverse consequences of renal insufficiency has seen the use of pharmacologic agents undergo considerable investigation (Lameire, Biesen, Hoste, & van Holder, 2009). Despite the abundance of statistical well-powered studies investigating the use of pharmacologic agents the observations made have proven to be disappointing in regards to detecting a protective effect on kidney function. Although some of the interventions to support kidney function have been shown to be effective in the immediate management of the critically ill patient, there is the potential to cause harm when caution is not exercised in the application of these drugs and only limited evidence to suggest improvement in renal recovery.

Diuretics.

The development of oliguria has been identified in a number of studies as being a predictor of worsening renal function in patients diagnosed with AKI. Non-oliguric patients have instead been shown to be associated with fewer complications, reduced need for RRT, shorter hospital stays and a lower mortality rate (Brivet, Kleinknecht, Loirat, & Landais, 1996; Shilliday, Quinn, & Allison, 1997). The practice of using diuretic therapy to ‘convert’ oliguric to non-oliguric ARF is an approach often used in the management of the critically ill patient to correct the accumulation of excess fluid and allow for the administration of blood products, vasopressor agents, antibiotic cover and nutritional support. During the BEST study the authors reported approximately 70% of critically ill patients who had sustained AKI leading to the loss of kidney function were administered diuretics in the management of excess fluid volume with 98.3% of participating organisations choosing to use the loop diuretic Furosemide (Uchino et al., 2004).

Furosemide is a loop-diuretic frequently used in clinical practice to induce a diuresis in the management of the critically ill patient who has low urinary output and requires the regulation of excess fluid volume (Uchino, Doig, et al., 2004). Under

experimental conditions Furosemide has been shown to increase medullary oxygenation suggesting a protective effect on kidney function due to a reduction in oxygen consumption required for active transport by the tubular system (Brezis & Rosen, 1995). Although the use of loop-diuretics may assist the management of fluid volume in the critically ill patient (if a diuresis is achieved) there is no evidence to suggest the outcome of patients with ARF is improved. Several RCTs reviewed in a meta-analysis on the use of loop diuretics for the management of ARF have not shown an increase in survival or recovery of renal function (Ho & Sheridan, 2006). Out of the nine RCTs reviewed a number of the investigations analysed comprised of small sample sizes of less than 100 patients and admission to ICU not specified. This may have affected the results obtained when renal function, the requirement for RRT and patient survival were evaluated between the experimental and control groups. As a result of low statistical power the appearance of marginal differences in patient outcomes are difficult to detect from the results reported in the meta-analysis. The ability to make inferences from the meta-analysis was also limited by the inclusion of a study which evaluated the responses to Furosemide administration both in the prevention as well as for the management of ARF. Despite these shortcomings in the meta-analysis by Ho and Sheridan (2006) the absence of a significant improvement in the outcomes of patients was supported when a similar meta-analysis also found no evidence of an improvement in patient survival or in the recovery of renal function (Bagshaw, Delaney, et al., 2007). Although the five RCTs selected by the authors had been reviewed previously, the statistical criteria applied for this meta-analysis only included investigation of patients once the presence of ARF had been established. The observations reported upon in both of the meta-analyses were nevertheless constrained by the limited number of RCTs and the quality of methods used. A large multi-centre RCT is required to increase statistical power in view of the possibility that the affect of loop diuretics on renal recovery and patient survival in established ARF may only be detectable when larger sample sizes are analysed.

The administration of loop-diuretics which successfully converts oliguric to non-oliguric ARF will assist in the removal of excess fluid but has not been shown to influence the natural progression of the original injury. The restoration of urinary output may instead serve to conceal the severity of renal damage, or simply indicate a milder form of ARF has occurred rather than providing evidence of an effective treatment strategy. Once a decision has been made to administer the loop-diuretic careful

consideration should be given in regards to the patient's volume status, duration in the exposure of the diuretic agent limited to a specific length of time and dose, and the goal of bringing about a diuresis not a justification for postponing RRT. The use of loop-diuretic therapy for critically ill patients with established oliguric ARF complicated by the accumulation of excess fluid is an appropriate treatment strategy when an overload of volume has resulted in respiratory distress, or other therapeutic interventions require the administration of additional fluid (Bagshaw, Bellomo, & Kellum, 2008).

Mannitol is an osmotic diuretic which has also been used for the purposes of renal protection in patients who are considered at risk of developing ARF (Schetz, 2004). The action of Mannitol induces a diuresis to flush out cellular debris and casts which might occlude the tubular lumen, to preserve the mitochondrial function of cellular activity by reducing the swelling of ischaemic tissue, and to assist in the scavenging of free radicals. The osmotic diuresis which accompanies the administration of Mannitol is associated with intravascular volume depletion when not accompanied by hydration and can increase medullary oxygen consumption due to the upsurge of activity in the distal tubule (Schetz, 2004). Studies which have investigated the use of Mannitol have not demonstrated a reduction in the incidence of ARF. The administration of Mannitol was not shown to have a protective effect on kidney function and may have caused a delay in the recovery of renal function when comparisons were made with hydration alone for the prevention of radio-contrast nephropathy (Solomon, Werner, Mann, D'Elia, & Silva, 1994). The absence of a protective effect using Mannitol was again reported following a retrospective study of 24 patients at risk of developing ARF diagnosed with rhabdomyolysis. Observations taken during the management of rhabdomyolysis demonstrated the inclusion of Mannitol made no difference to kidney function when comparisons of SCr levels were measured against those taken from patients who had only hydration administered (Homsí, Barreiro, Orlando, & Higa, 1997). The ability of Mannitol to induce a diuresis and maintain urinary output has not translated into an effective pharmacologic strategy for the prevention of ARF. Studies which have investigated the use of Mannitol have been of insufficient statistical power to completely exclude the possible benefit of the diuretic agent in the protection of renal function. But in view of the limited evidence available to suggest the diuretic agent has a protective effect on kidney function and aggravation of renal insufficiency observed during radio-contrast administration the use of Mannitol for the prevention of ARF can no longer be recommended.

Low-dose Dopamine.

Low-dose Dopamine (1-3 micrograms [μg] per kg per min intravenously) is a renal vasodilator acting on dopaminergic receptors in the kidney (Hollenberg, Adams, Mendall, Abrams, & Merrill, 1973). At this dose Dopamine has been shown under experimental conditions to augment renal blood flow causing an increase in urinary output independent of changes in renal perfusion pressure. The use of low-dose Dopamine as a continuous infusion has been used with some success (Polson et al., 1987), but over time has failed to produce convincing evidence of its protective effect on renal function. A meta-analysis of over 50 published studies investigating the effect of Dopamine showed no evidence of a reduction in the incidence of AKI, the requirement for RRT or an improvement in patient survival to support its continued use for the prevention or management of ARF (Kellum & Decker, 2001). The large multi-centre study undertaken by the ANZICS Clinical Trials Group (Bellomo, et al., 2000) assessed the effectiveness of low-dose Dopamine in the management of intensive care renal failure. A total of 328 critically ill patients with Systemic Inflammatory Response Syndrome (SIRS) and renal dysfunction were randomised in a double-blind study to receive either low-dose Dopamine at $2\mu\text{g}$ per kg per min or the placebo. The intervention continued until there was resolution of ARF, the requirement for RRT or death had occurred. There was no difference in patient demographics, severity of illness and duration of treatment with the peak SCr concentration used as the primary measurement of outcome. The study demonstrated low-dose Dopamine made no effect in the treatment of ARF as opposed to hydration alone. The SCr level and urine output at one hour, 24 hour and 48 hour and the requirement for RRT were equivalent between the groups whilst significantly different from baseline measurements on commencement of the study ($P\text{-value} < 0.01$). This was a well designed and rigorous study which demonstrated no support for the continued use of low-dose Dopamine for the prevention or treatment of ARF in the critically ill patient.

N-acetylcysteine.

N-acetylcysteine has been suggested as another pharmacologic agent which can be used with hydration to prevent deterioration of kidney function (Lameire, De Vriese, & Vanholder, 2003). The antioxidant properties of acetylcysteine scavenge oxygen-free radicals and reduce ischaemia by causing endothelial vasodilation (DiMari et al., 1997). The use of N-acetylcysteine for renal protection against radiographic contrast dyes has been evaluated in several RCTs but with conflicting results on the response observed

(Durham et al., 2002; Kay et al., 2003; Tepel et al., 2000). Many of the studies evaluated made omissions in regards to describing the dose of N-acetylcysteine required and when the agent should be administered. To clarify the degree of benefit observed several meta-analyses have examined these studies collectively (Alonso, Lau, Jaber, Weintraub, & Sarnak, 2004; Birck et al., 2003; Isenbarger, Kent, & O'Malley, 2003). Although some studies had shown no benefit, the overall recommendation from each of the systematic reviews support the use of N-acetylcysteine as a strategy to decrease radiographic contrast nephropathy. The effect is more noticeable in patients who have chronic renal insufficiency and administration of N-acetylcysteine should be combined with hydration before the diagnostic procedure. The protective effect of N-acetylcysteine on renal function has encouraged other investigators to explore whether the same benefit is extended to patients after major surgery. Other studies investigating the use of N-acetylcysteine as a renal protection strategy for none radiographic contrast injury has been collectively reviewed in several meta-analyses (Ho & Morgan, 2009; Nigwekar & Kandula, 2009). The meta-analyses of predominantly randomised controlled studies in the absence of radiographic contrast have not shown a beneficial effect of N-acetylcysteine in the prevention of renal dysfunction after major cardiovascular surgery.

A number of preventative measures can be taken to protect the critically ill patient from AKI. The maintenance of adequate renal perfusion pressure requires assessment of circulatory volume and the correction of hypovolaemia. This may require the instigation of intravenous fluid expansion and the commencement of vasopressors. Once cardiac output has been stabilised only then should pharmacological interventions be considered. The use of N-acetylcysteine for protection against radiocontrast-induced nephropathy is the only drug shown to be effective in the prevention of AKI. Loop-diuretics allow the removal of excess fluid but are not associated with increased patient survival or improved recovery of renal function. The use of low-dose dopamine as a renal vasodilator is now no longer justified with the absence of any evidence to support the continued use of the drug in clinical practice.

Summary

The vulnerability of critically ill patients to the incidence of AKI and the development of ARF demonstrate the important place management of renal function holds in the care of the critically ill patient. Aspects of normal kidney function summarised in the background to this thesis demonstrate the vital role the renal system

plays in the maintenance of water and electrolyte balance, the removal of metabolic waste products and in the regulation of acid-base balance. Various markers of kidney dysfunction described are associated with several definitions used to quantify the severity of AKI. The causes of AKI are divided into categories according to the location and related pathology with the development of ATN the most common injury observed in the critically ill patient. A lack of definition regarding the measurement of injury to the kidneys has until recently made the epidemiology of ARF unclear, but efforts to reach consensus on a quantitative definition of AKI has led to a greater understanding on the degree of organ dysfunction experienced. The consequences of ARF focus on the sudden loss of kidney function causing volume overload, electrolyte disorders, retention of organic compounds and metabolic acidosis. The implementation of measures directed at preventing single or multiple injuries to the kidneys include strategies which maximise blood flow by the maintenance of cardiac output, the expansion of intravascular fluid volume and the preservation of organ perfusion pressure. A variety of pharmacologic strategies used for the prevention of AKI and in the management of ARF have been discussed which may prove useful in some situations. Should both general preventative measures and specific renal protective strategies not prevent the development of AKI, then the option of techniques designed to ‘artificially’ replace kidney function becomes inevitable. This thesis explores the current knowledge of these approaches for critically ill patients, and investigate how best to sustain these treatments from one specific approach.

CHAPTER 2

LITERATURE REVIEW

Acute Renal Failure in the critically ill patient is associated with a high mortality rate or, following recovery from the initial illness, the possibility of permanent renal insufficiency. The prevention of AKI requires prospective identification of those patients who are at risk of developing renal insufficiency by the avoidance of nephrotoxic agents, the provision of adequate hydration and haemodynamic support and consideration given to pharmacologic strategies. Once attempts to correct or ameliorate the physiological consequences of AKI have failed and there is a continued decline in renal function some form of RRT is required (Fieghen, Wald, & Jaber, 2009).

Various approaches to RRT include the use of extracorporeal techniques which support kidney function intermittently or continuously. The importance of maintaining continuity of treatment in the application of the 'continuous' approach to RRT forms the basis of the literature review with the success of this technique being dependent on the ability to achieve adequate circuit life. In undertaking the literature review a systematic approach was used during the search strategy to source appropriate material. The search strategy included a PUBMED database search from 1990 to December 2010 using the key words: Renal Replacement Therapy; Critical Illness; Circuit Life; Patient Outcomes. The date of publications was widened to include material on the development of renal support therapies when as a result of technological improvements changes occurred in the management of the critically ill patient. Only articles written in the English language were selected. The bibliographies of selected articles were also examined for relevance. The results of the search strategy identified 90 review articles, four meta-analyses, 41 randomised controlled trials, 87 prospective and 11 retrospective observational studies, five surveys or quality audits, two case reports, two quality assurance projects, and three editorial or viewpoints. A list of material sourced during the literature review is provided in Appendix A. The publication of research papers were reviewed and the findings of each study evaluated according to the levels of evidence proposed by the National Health and Medical Research Council (NHMRC) (2005). The information obtained from the literature search was sorted and placed into two broad categories: the management of severe ARF in the critically ill patient and the successful

application of CRRT. The approach used assisted in how information was processed during the literature review and in the way information on the topic was presented.

The management of severe ARF which requires the instigation of RRT forms the first part of the chapter, and in the context of the critically ill adult patient, comprise of techniques which utilise extracorporeal circulation technologies. An explanation on the theory of solute and plasma water transport through a semi-permeable membrane demonstrate how the use of convection and diffusion allow extracorporeal techniques to mimic the actions of the kidneys in the removal of excess fluid and metabolic waste products and in the control of acid-base balance. The importance of solute clearance is discussed along with consideration given to early rather than late commencement of treatment. Both intermittent and continuous approaches to RRT are commonly used to manage severe ARF in the ICU. An historical account is provided on the development of CRRT and in the choice of contemporary treatment modes. The discussion is followed by a comparison with IHD in the effectiveness of CRRT to improve patient survival and promote the return of kidney function, as well as issues concerning the use of each approach in clinical practice.

The second aspect of the chapter focuses on the application of CRRT and considers the longevity of the extracorporeal circuit as fundamental to the successful implementation of the technique. To achieve electrolyte balance and acid-base control particular attention must be given to the composition of solutions used for CRRT. The intensity of dose delivered to the patient will also influence the treatment's effectiveness to correct the degree of renal insufficiency present. Although not able to operate 'ad infernitum' the longevity of the circuit is an important aspect of the technique. The circuit is exposed to a variety of factors which impact on the ability of the technique to deliver treatment which is effective. A review of the physiological factors associated with extracorporeal circulation such as exposure of the blood coagulation system to non-biological surfaces and the use of anticoagulation strategies to sustain circuit life, is followed by an examination of the mechanical factors which can also influence the longevity of the circuit such as operational training in the use of equipment and the design features of the extracorporeal circuit. The importance placed on achieving adequate circuit life when using the 'continuous' approach to RRT is fundamental in efforts to maximise the amount of treatment time delivered to the patient. Other concerns regarding the duration of each circuit using the technique include the workload sustained by the critical care nurse in the preparation and set-up of CRRT, in the

containment of costs associated with the expenditure of single-use items and in the extent of blood loss incurred due to the repeated circuit failure. The potential for convective versus diffusive mechanisms to act as an independent factor in the maintenance of circuit life is discussed and the issue of differences in the transport of solutes and plasma water between alternative treatment modes identified in the literature review as an area of study which requires further investigation.

Management of Severe ARF in the Critically Ill Patient

The collection of renal protective strategies reviewed in the previous chapter may prove unsuccessful in preventing or correcting a sudden loss of kidney function. Metnitz and colleagues (2002) in a prospective multi-centre epidemiological study reported the requirement for RRT due to a deterioration in renal function occurred in 4.9% of patients admitted to ICU. The methods used to replace renal function and control the body's internal environment fall into two main categories: extracorporeal techniques which include a blood filter (Bellomo & Ronco, 1999), or the surgical placement of an indwelling catheter in the peritoneal cavity which act as the filter membrane (Kelley, 2004). Classification of the different forms of extracorporeal RRT (excluding renal transplantation) are summarised in Figure 2.1. Intermittent Haemodialysis and CRRT incorporating CVVH are two types of extracorporeal therapies most commonly used in the ICU (S. John & Eckardt, 2007). Each approach relies on a veno-venous circuit and roller-pump technology to circulate blood outside of the body through a haemodialyser or haemofilter. Excess fluid and unwanted substances are discarded as 'spent' dialysate or as ultrafiltrate and the 'cleaned' blood returned back to the patient.

The option of performing peritoneal dialysis (PD) is a technique not routinely used for the management of ARF in the critically ill adult patient (Uchino, et al., 2005). Only patients with an intact peritoneal cavity are suitable for the technique with the inherent risk of infection a potential complication along with the possibility of respiratory insufficiency due to the requirement for the dialysate to remain in the cavity during the dwelling phase of the procedure. A concern regarding the overall ability of the technique to remove fluid efficiently and gain metabolic control when compared with the alternative choice of extracorporeal therapies makes PD less attractive to use in the hypercatabolic patient with severe renal insufficiency. The use of PD was shown to take longer in the restoration of acid-base balance and to bring about a reduction in the

concentration of SCr, a shorter duration was also observed in patients who were randomised to receive CVVH (Phu et al., 2002).

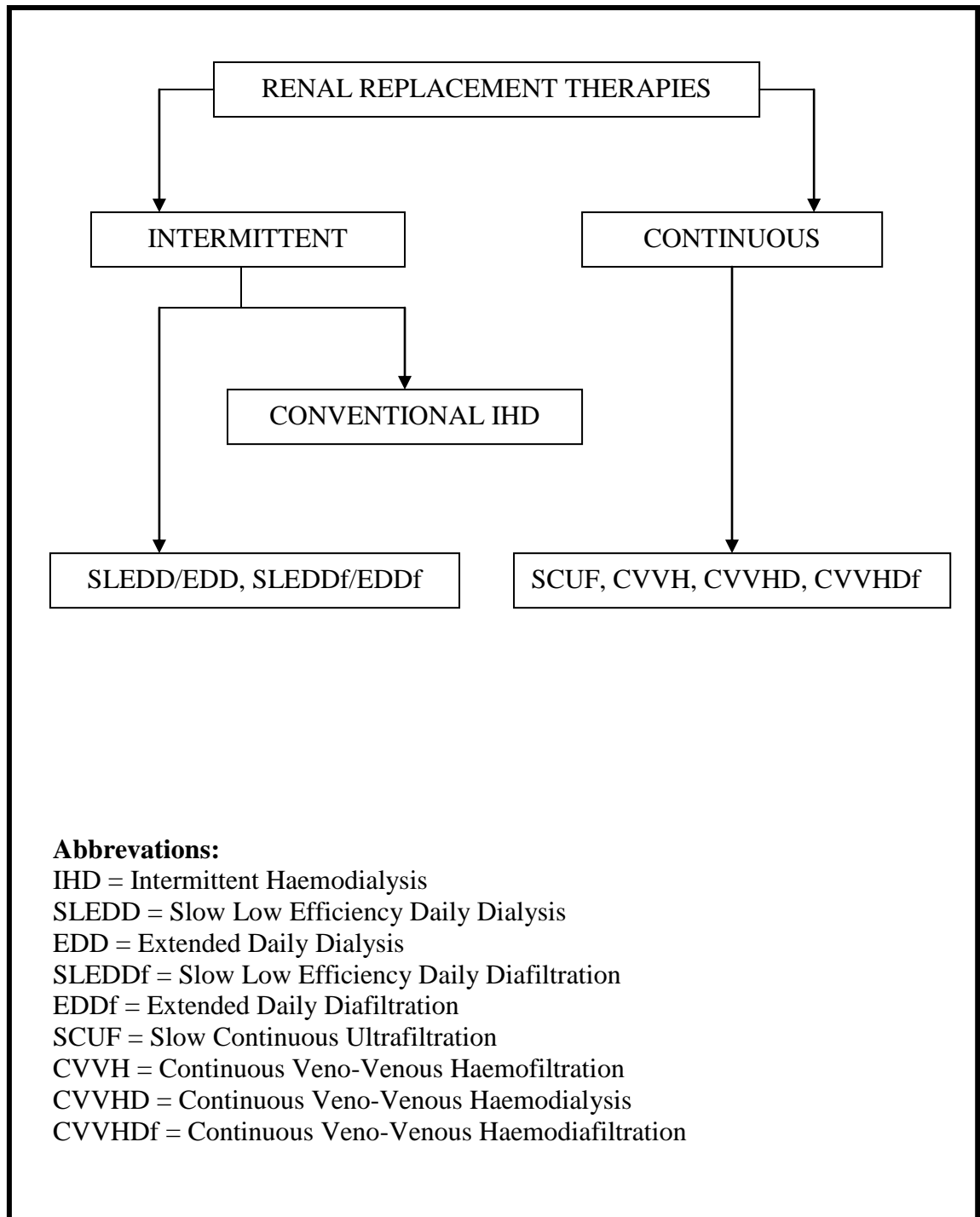

Figure 2.1. The Classification of Extracorporeal Renal Replacement Therapies.

Mechanisms of Solute and Plasma Water Transport

The use of extracorporeal therapy to support renal function in the removal of solutes and the control of excess plasma water requires an understanding of the

mechanisms at work when blood is circulated through an ‘artificial kidney’. An attempt is made using semi-permeable membrane technology and extracorporeal circulation to artificially replicate the actions of the nephron described in the previous chapter as the functional unit of the kidney. The reproduction of a concentration gradient between extracorporeal blood and the membrane during haemodialysis mimics the movement of solutes which normally occurs by diffusion along different segments of the tubular system (Sarkar, 2009). The alternative process of haemofiltration instead resembles the operations of the glomerulus by using blood flow through the extracorporeal circuit to create hydrostatic pressure in forcing plasma water and solutes across the semi-permeable membrane. In the absence of the tubular system normally associated with the reabsorption of plasma water and substances such as the recycling of bicarbonate, the manipulation of extracorporeal blood is achieved by making adjustments to the delivery of replacement fluid, composition of the dialysate solution and pore size of the semi-permeable membrane. Other important functions performed by the kidney are presently not able to be replicated by extracorporeal membrane technology.

Diffusion

The predominant method of solute removal which occurs during haemodialysis involves the process of diffusion with the movement of dissolved substances governed by differences in the concentration gradient of two separate solutions (blood and dialysate) across a semi-permeable membrane (Misra, 2008). As a result of thermal kinetic energy substances within the blood and the dialysate randomly move around, and over time attempt to achieve an even solute distribution on either side of the membrane. Solute removal by diffusion occurs when the equilibration across the membrane shown in Figure 2.2 is prevented, and a lower solute concentration maintained in the dialysate continues to draw substances out of the blood. The diffusive flux of a particular solute (J_d) through a semi-permeable membrane depends on the diffusivity (D) of the solute, the surface area (A) of the membrane and the temperature of fluid which are inversely proportional to the concentration gradient (dc) over the thickness of the membrane (dx) [$J_d = D \cdot A \cdot T (dc/dx)$] (Ronco & Levin, 2005).

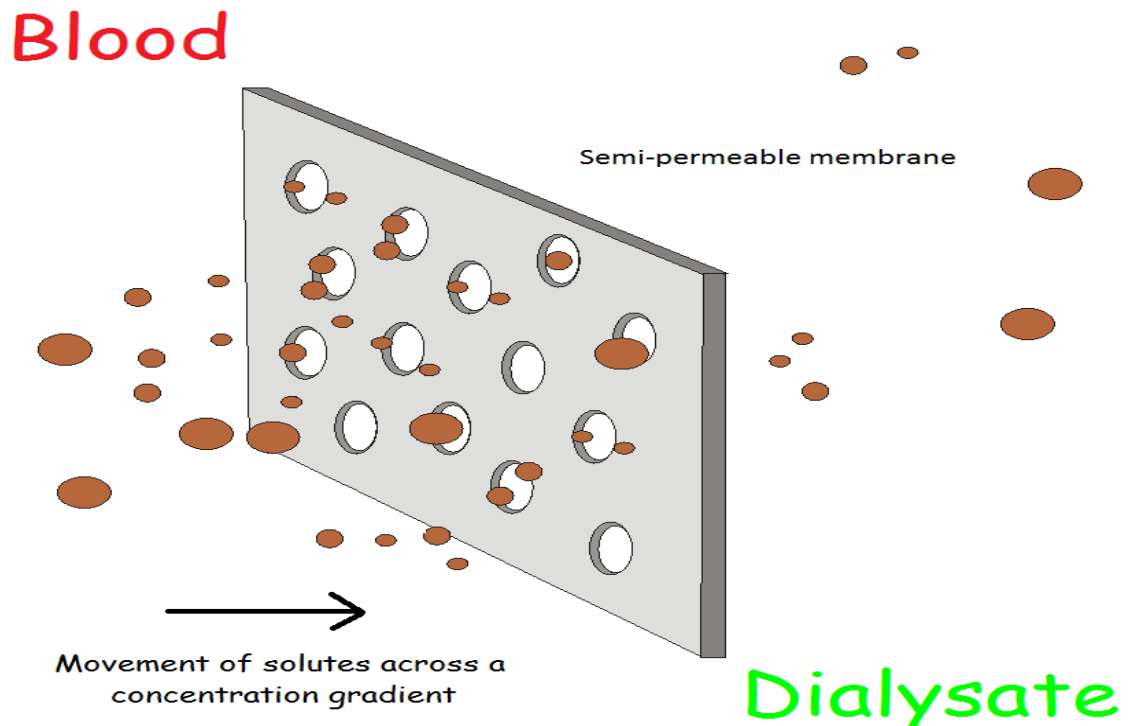

Figure 2.2. An illustration of solute movement by diffusion.

Convection

The removal of solutes during haemofiltration shown in Figure 2.3 is predominantly by convection caused by the movement of plasma water due to the flow of blood and the pressure gradient across the semi-permeable membrane. The convective flux of a particular solute (J_c) through a semi-permeable membrane depends on the ultrafiltrate rate (Q_f), the concentration of solute in plasma water (C_b) and the sieving coefficient of the solute (S) [$J_c = Q_f \cdot C_b \cdot S$] (Ronco & Levin, 2005). The sieving coefficient is a measure of how easily a solute can filter through the membrane by convection. The ideal sieving coefficient of a solute should achieve parity with the membrane (σ) [$S = 1 - \sigma$].

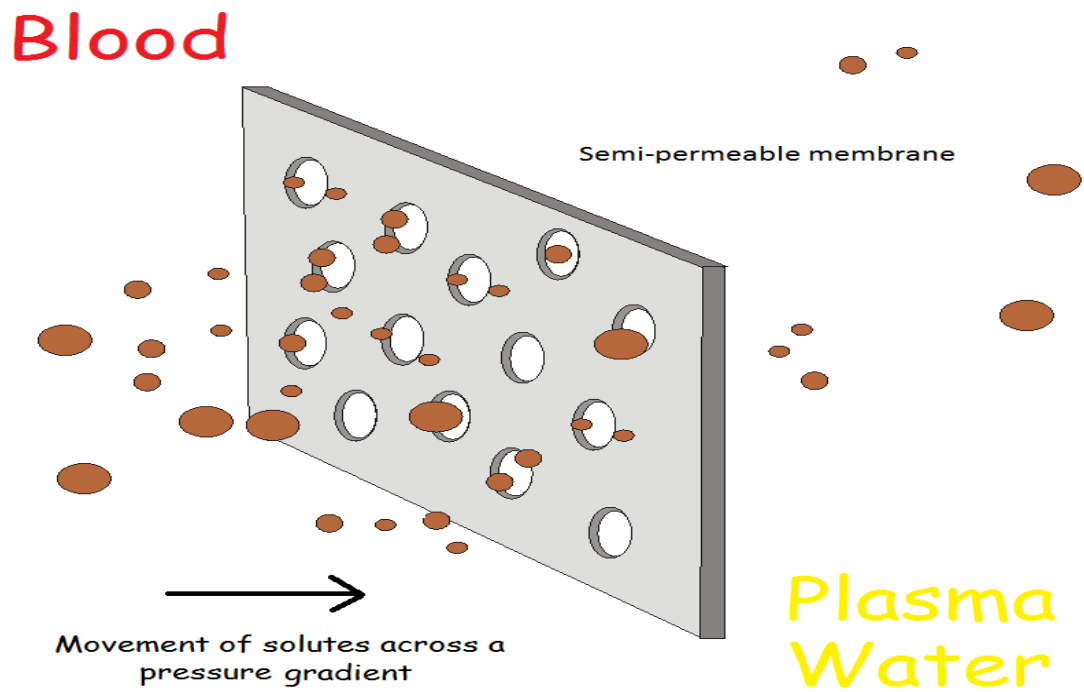

Figure 2.3. An illustration of solute movement by convection.

Ultrafiltration

Ultrafiltration refers to the separation and movement of water plasma from whole blood shown in Figure 2.4 due to a transmembrane pressure difference in favour of hydrostatic pressure over the oncotic pressure exerted by blood plasma (Bellomo & Ronco, 2002b). The rate of ultrafiltration (Q_f) which occurs is dependent on the membrane ultrafiltration coefficient (K_m) and the transmembrane pressure (TMP) gradient generated by the different pressures on each side of the membrane [$Q_f = K_m \times \text{TMP}$].

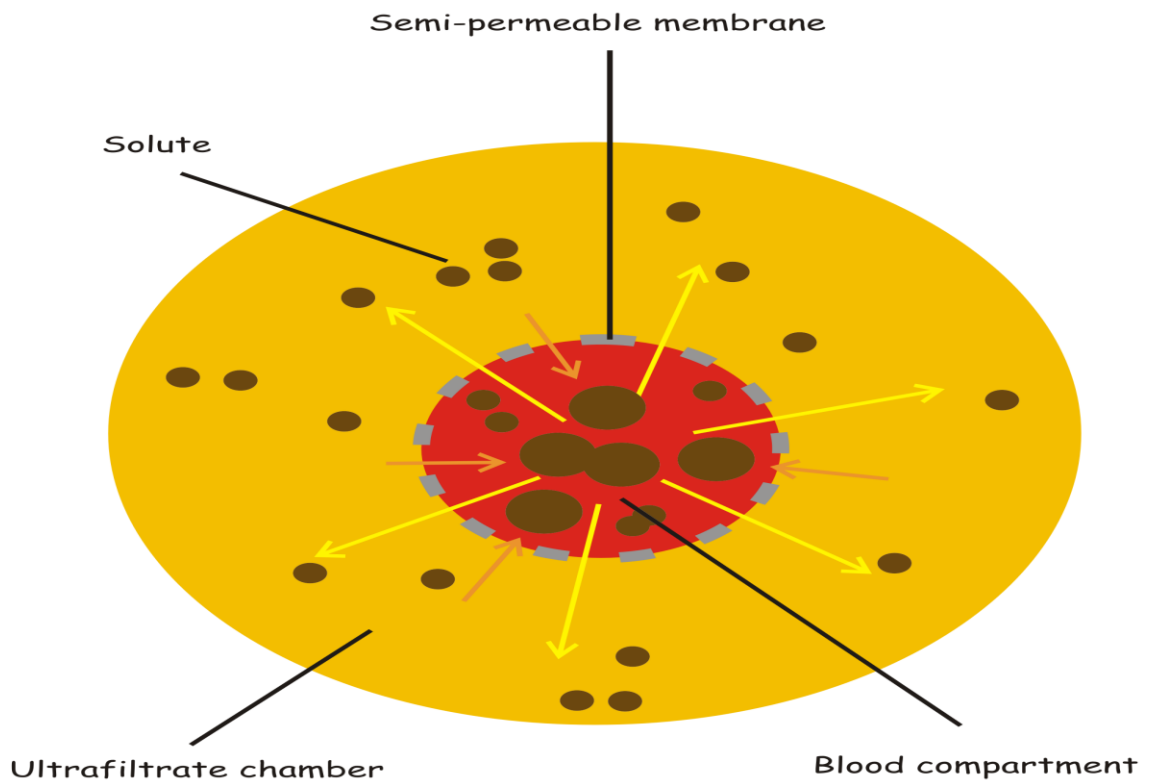

Figure 2.4. An illustration of plasma water movement by ultrafiltration.

Adsorption

Once blood is exposed to an artificial membrane the non-biological material causes almost instantaneous adsorption of plasma proteins and as shown in Figure 2.4 other substances onto the surface area of the membrane (Huang, Gao, Letteri, & Clark, 2009). The construction of membranes with synthetic material have a negatively charged surface area which increases the adsorption of plasma proteins and in response contribute to activation of the coagulation pathway. The adsorption of plasma proteins can be considered a form of solute removal with the capacity to remove a variety of solutes by adsorption also dependent on the polarity of the materials used to manufacture the membrane. The adsorptive capacity of the membrane decreases when the surface area of the membrane becomes saturated and the occlusion of pores causes fouling of the semi-permeable wall to adversely alter the performance of the membrane in the movement of solutes (Huang, et al., 2009).

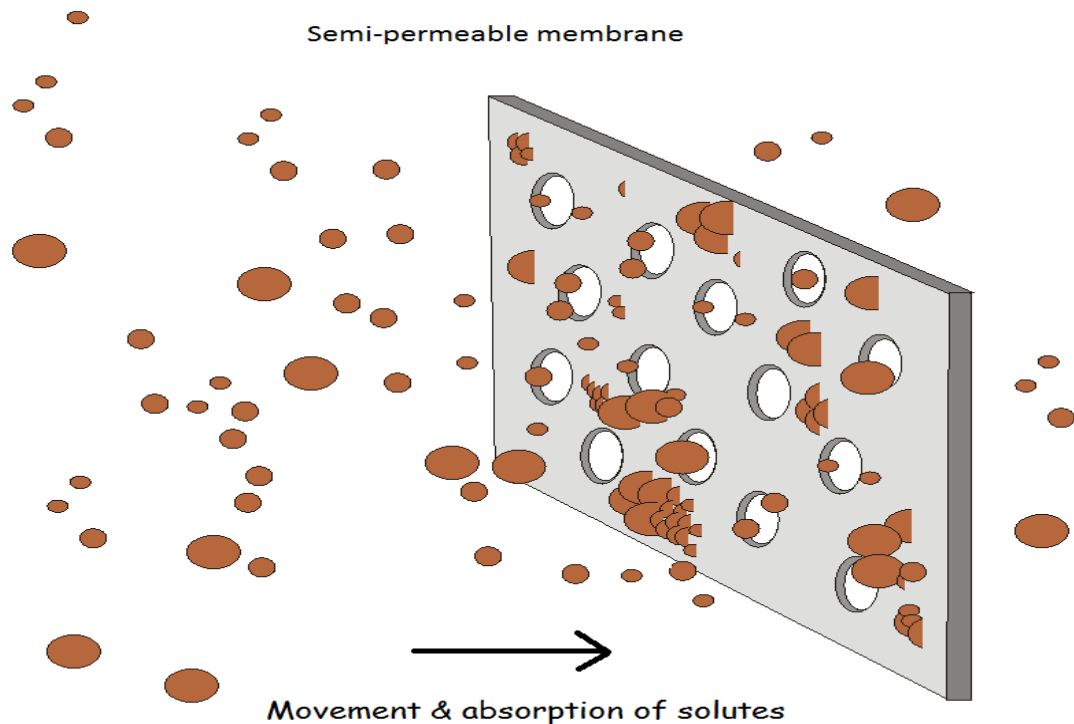

Figure 2.5. An illustration showing the movement of solutes and absorption along the semi-permeable membrane.

The mechanisms of solute and plasma water transport during extracorporeal RRT are processes where the individual contributions of diffusion and convection are unable to be singled out separately producing a different response which otherwise would not occur when the processes are independent of each other (Ronco & Levin, 2005). This is particularly evident in therapies like haemodiafiltration which use a combination of both transport mechanisms and a ‘struggle’ can develop between diffusion and convection in the movement of solutes and plasma water. A localised difference in the concentration gradient across the membrane may for example interfere with the transfer of solutes when increased movement by diffusion causes a reduction in the capacity to transport solutes by convection. The opposite effect can occur when for example specific areas of the membrane become vulnerable to protein adsorption after ultrafiltration increases the movement of solutes by convection. The adsorption of plasma proteins is often accompanied with a thickening of the protein layer which can diminish solute transport by diffusion. An understanding of the exchange which occurs between diffusion and convection is important since the design features of the blood filtration device and characteristics of the artificial membrane influence the method of

transport which occurs in the removal of solutes and plasma water and how these may change as the membrane ages during use.

Artificial Kidney

The functional component of all extracorporeal RRTs is the blood filtration device, known as the haemofilter or haemodialyser. Each device is connected to the extracorporeal circuit packed with a semi-permeable membrane and placed within a plastic outer casing to construct the artificial kidney (Sakai, 2000). Although able to remove excess fluid and soluble particles from the blood similar to the actions of the kidney, both devices do not have the capacity to mimic the important regulatory mechanisms of the organ. A basic feature of the blood filtration device is the inclusion of external ports on either end of the structure for the passage of blood and in the positioning of side ports to allow the entry and exit of fluid (Sakai, 2000). The inclusion of pathways within the haemofilter or haemodialyser channel blood and filtrate/dialysate for the greatest exposure to the membrane surface area of the device. Configuration of the haemofilter/haemodialyser originally consisted of flat membranes sandwiched together, but are now scarcely used in favour of contemporary membranes bundled together as hollow fibres. The advantages of selecting this type of membrane configuration included better distribution of flow into each channel which improved performance in the clearance of solutes and provided a more robust structure (Sakai, 2000). The flow channels created by the bundles of hollow fibres will determine whether the device is a haemofilter or haemodialyser. A device designed to primarily remove solutes by convection is classified as a haemofilter and comprises of membranes which accept high sieving coefficients for the passage of plasma water due to the force of hydrostatic pressure (Sigler & Manns, 1996). Optimization in the degree of ultrafiltration provides high-flux characteristics in the clearance of large-sized molecules by increased hydraulic permeability through the membrane. A device which is instead designed to primarily remove solutes by diffusion is classified as a haemodialyser and incorporates membranes which have thinner walls to facilitate the passage of solutes by a concentration gradient (Sakai, 2000). The low-flux nature of membranes traditionally used for haemodialysers limit the removal of solutes by the passage of plasma water due to the reduced hydraulic permeability of the device. Other blood filtration devices referred to as haemodiafilters are designed to optimise solute and fluid removal by diffusion and convection (Hoenich, 2007).

Artificial Membranes

A major factor influencing solute removal is determined by the ability of the artificial membrane to absorb water and the porosity of the material used to allow solutes of a specific molecular weight to pass through to the other side of the semi-permeable membrane (Golper, 2002). The materials which are used for the purposes of solute transport can directly affect the performance of the membrane. Substances which are dissolved in a solution normally move around at an equal rate when unrestricted. The insertion of a membrane can be designed to interrupt this naturally occurring phenomenon and restrict the passage of specific solutes by diffusion according to their molecular weight and the pore size of the semi-permeable membrane. Also, the force generated by the velocity of blood or hydrostatic pressure to create a pressure gradient across a membrane is influenced by the hydraulic permeability of the membrane (Golper, 2002), with the flux of transmembrane plasma water movement and subsequent solute removal by convection controlled by differences in hydraulic and osmotic pressures on either side of the membrane (Leypoldt, 2000). A sieving coefficient of 1.0 indicates complete permeability of the solute as it travels along each of the hollow fibres and through the membrane under pressure from the velocity of blood entering the haemofilter or haemodialyser. Small molecules are transported rapidly during diffusion but decreases when middle-sized molecules are diffused across the membrane with the opposite effect occurring when convective transport is increased for middle-sized molecules at the expense of molecules which are smaller in molecular size (Leypoldt, 2000). The degree of solute clearance achieved by diffusion and convection requires the volume of blood passing through the haemodialyser/haemofilter to be measured against the time a particular substance is removed from the blood (Golper, 2002). Urea is an example of a small solute able to be removed across the semi-permeable membrane and the response to solute movement monitored when the degree of BUN manipulation is measured. Mathematical modelling of fluid and solute transport can be used to calculate the clearance of substances according to the rate of blood flow (Q_b) and the flow rate of dialysis (Q_d) or ultrafiltration (Q_u) delivered (Waniewski, 2006).

Cellulose-based membranes such as Cuprophane were early examples of semi-permeable membrane technology and, because of the small pore size, are considered as 'low-flux' membranes with a permeability coefficient to water (K_m) of 5-6ml per hr x mmHg x m² (Ronco et al., 2003). The thin hydrophilic membrane wall (6-15µm) is

ideal for diffusive solute transport and favours the clearance of small-sized molecules at the expense of other substances which have a larger molecular weight (Clark & Ronco, 2001). In response to the limited removal of different sized molecules associated with cellulose membranes exploration of alternative materials led to the development of synthetic membranes. The manufacture of synthetic membranes has allowed the sieving coefficient of the semi-permeable membrane to include a wider spectrum of molecules and achieve a greater mass transfer through higher ultrafiltration volumes not possible using cellulose-based membranes (Ronco, et al., 2003). Attempts made during the late 1970s to manufacture synthetic membranes were initially asymmetrical in design and constructed from hydrophobic polyamide polymers with a wall thickness of 40-60 μm . As a consequence of increased hydraulic permeability (30-40mL/hr x mmHg x m²) these membranes were not efficient in the removal of solutes by diffusion but were successfully employed in convective therapies such as haemofiltration. Modifications made to the original composition and structural configuration of the plastic polymers used to construct synthetic membranes has improved the diffusive properties of these membranes without affecting the convective quality of the high-flux nature of the semi-permeable wall (Ronco, et al., 2003).

Debate continues in the literature on whether the flux of a membrane and the clearance of different sized molecules is a factor which may contribute to an improvement in the outcome of critically ill patients with ARF. Ponikvar and colleagues (2001) found no significant difference in the survival (P-value = 0.784) or return of renal function (P-value = 0.816) in 72 patients who received IHD following a randomised comparison of low-flux versus high-flux synthetic membranes. The use of high-flux membranes is recommended for CRRT in order to improve water permeability of the semi-permeable wall and allow the clearance of solutes by haemofiltration (C. H. Jones, 1998). As well as increasing the flux characteristics of the semi-permeable wall another reason for the use of synthetic materials to construct the artificial membrane has been associated with improvements in biocompatibility. This term is used to describe the tolerance and reactivity of materials used in the construction of membranes when they are exposed to the patient's immune system.

Although the duration of blood-membrane interaction is reduced when compared with the increased exposure which occurs during CRRT, cellulose-based membranes most associated with conventional IHD are more likely to cause complement and coagulation cascade activation (Hakim, 1993). The use of non-

biocompatible materials with conventional IHD stimulate monocyte activity and the release of cytokines, as opposed to reduced activation when bio-compatible membranes made from synthetic materials are used during CRRT (C. H. Jones, 1998). Several studies of patients with ARF requiring haemodialysis have shown survival and recovery of renal function is either improved with synthetic polyacrylonitrile and polymethylmethacrylate membranes (Hakim, Wingard, & Parker, 1994; Himmelfarb et al., 1998; Schifffl et al., 1994), or is no worse when compared with modified cellulose-based membranes (Gastaldello et al., 2000; Jorres et al., 1999). A meta-analysis of membrane biocompatibility and the effect on patient outcomes in the treatment of ARF advocates the use of synthetic membranes (Subramanian, Venkataraman, & Kellum, 2002). Despite patients with ESRD being previously managed successfully using cellulose-based membranes there application has declined in recent years due to complications associated with the effects of repeated exposure, and are not recommended when considered for use during the management of patients with ARF (Pastan & Bailey, 1998).

Extracorporeal Renal Replacement Therapy

The use of extracorporeal RRT in the management of the critically ill patient with severe ARF continues to be dominated in North America by IHD (Hyman & Mendelssohn, 2002; Mehta & Letteri, 1999) whilst in Europe (Liano, et al., 1998; van Bommel & Ponssen, 1997; Wright, Bodenham, Short, & Turney, 2003), Australia and New Zealand (RENAL Replacement Therapy Study Investigators, 2008; Silvester, et al., 2001) CRRT remains the most preferred technique employed. A number of recent international surveys have also reported the uptake of 'hybrid therapies' as a form of RRT now used in some ICUs for the management of ARF (Overberger, Pesacreta, & Palevsky, 2007; Ricci, Ronco, D'amico, et al., 2006). The instigation of RRT is influenced by the magnitude of injury the kidney has sustained and the affect changes in renal function may have on the performance of other organs. In the critically ill patient the timing of when to instigate RRT can have a major influence on survival and restoration of renal function.

Early rather than late?

The decision to commence RRT using extracorporeal technology is currently not based on any specific evidenced criteria as to the precise moment when to intervene in the management of critically ill patients with AKI. Although the indications for RRT are

widely accepted the precise moment to initiate correction of excess fluid, hyperkalemia, metabolic acidosis and uraemia is subject to differences of opinion (Overberger, et al., 2007). In the critically ill patient the development of ARF is often associated with the dysfunction of other organs and the timely provision of RRT viewed as a form of renal support rather than the complete replacement of renal function. A number of reasons have been put forward why early rather than late initiation of RRT should be considered. The severity of physiological derangements can outweigh the potential harm of complications associated with commencement of RRT (the risk of injury during the insertion of vascular access device), or when using alternative conservative management strategies, there is no benefit in waiting for the possible recovery of renal function if failure of other organs has a greater impact on patient survival. The commencement of RRT for the management of excess fluid accumulation can improve lung function and increase the oxygenation of other organs in the absence of traditional indices of marked azotemia as a trigger to commence treatment (Payen et al., 2008). Studies investigating the ideal time to commence RRT have only recently been the subject of retrospective and prospective analyses. Since the recognition that ARF has been shown to be an independent risk factor which can increase patient mortality (Levy, et al., 1996), the possibility that optimisation of renal support may improve survival has led to several prospective evaluations of early versus late initiation of RRT.

In a retrospective study by Gettings and colleagues (1999) the timing of CRRT was shown to influence the mortality rate of patients with post-traumatic ARF. Patients were classified according to when they commenced CRRT based upon either a BUN < or > 21mmol per L. Despite receiving the same intensity of treatment the authors reported a significant improvement in patient survival when CRRT was initiated with a lower BUN level compared to the survival of patients if the BUN level was much higher on commencement of CRRT (patient survival 39% early initiation group versus 20% in the late initiation group, P-value = 0.041). Whilst the findings suggest a benefit in the early commencement of CRRT the observations may have been influenced by differences in decisions which led to when treatment was commenced. Although baseline demographic characteristics and severity of illness scores were similar, no reason was provided by the authors why some patients were selected for the early as opposed to the late intervention group, and the timing of treatment may have been confounded by decisions based according to which intensive care specialist was prescribing. The inconclusive results of retrospective investigations have led researchers

to conduct prospective comparisons of early versus late RRT prospectively. In one study undertaken by Bouman and colleagues (2002) randomisation of 106 patients into three alternative treatment groups observed the impact on patient survival using early high-volume Continuous Venovenous Haemofiltration (CVVH) (72 to 96L per 24hr), versus early low-volume CVVH (24 to 36L per 24hr), versus late low-volume CVVH (24 to 36L per 24hr). The criteria used to determine when CVVH should be initiated differed among the early and late treatment groups. In the two early groups treatment was initiated after 12 hours (early high-volume and early low-volume CVVH). This was based on the development of oliguria despite efforts to maximise haemodynamic parameters, or after urine collection measured creatinine clearance less than 20ml per min. In the third group (late low-volume CVVH) treatment was not commenced until BUN levels were greater than 40mmol per L, potassium was greater than 6.5mmol per L, or there was evidence of pulmonary oedema. On completion of the study Bouman and colleagues (2002) found no significant difference in patient survival at 28 days between the three treatment groups. In the early high-volume CVVH treatment group 74.3% of patients remained alive compared with 68.8% in the early low-volume CVVH treatment group and 75.0% in the late low-volume CVVH treatment group (P-value = 0.80). Out of the total population of haemofiltered patients who survived ICU the lower mortality rate of 57% observed by Bouman and colleagues (2002) suggests the severity of illness among patients who participated in the study may not have been as severe when compared with the higher mortality rate of 76.8% observed in patients who had required RRT during the BEST study (Uchino, et al., 2005). A difference might have occurred in the survival of patients allocated to receive early high-volume and early low-volume CVVH had Bouman and colleagues (2002) included patients who may not have otherwise survived had they been assigned to the group of patients allocated to receive late low-volume CVVH.

A review of the literature of comparisons between early and late RRT have not been able to demonstrate a set of criteria for the commencement of RRT which is associated with an improvement in patient outcomes. The criteria used during the BEST study, to determine the prevalence of ARF and requirement for RRT defined the trigger for the initiation of treatment as a urine output of less than 200ml in 12hr and/or a BUN level > 30mmol/L (Uchino, et al., 2005). In the opinion of the authors the criteria chosen included a set of values which closely resembled practice already undertaken by organisations who participated in the study. Using the same data from the BEST study

late as opposed to early commencement of RRT was associated with a decrease in patient survival or increased dependence for survivors of continued renal support (Bagshaw et al., 2009). Observations made by the authors suggest the findings were largely dependent on how early versus late timing of RRT was defined in the criteria used to initiate treatment. The suggestion of improved outcomes when RRT is initiated early may be a reflection of the differences in the severity of AKI which, in some patients if managed conservatively would be resolved regardless of whether the alternative approach of RRT was used in the management of the patient. The example of a generally agreed upon criteria for the initiation of RRT will remain as a guide until specific biomarkers or clinical predictors are developed indicating the degree of injury which has occurred to the kidneys. This will enable a randomised, controlled study to be undertaken which can accurately identify patients who are at risk of severe AKI, and avoid the inclusion and randomisation of patients with a less severe form of AKI who would otherwise would not normally require RRT. The commencement of RRT is nevertheless regarded as important should the severity of injury sustained by the patient require the support of kidney function. Instead of waiting for oliguria and increasing blood urea levels the instigation of early rather late RRT is preferable to complications caused by renal insufficiency and the development of MOD. Once a decision has been made to commence RRT management of the critically ill patient involves extracorporeal techniques which are prescribed intermittently (4-8hr per day) or continuously (24hr per day).

Intermittent Haemodialysis

The management of severe ARF using IHD is based on the technique originally developed for the management of patients with ESRD (Pendras & Erickson, 1966). Soon after the technique was introduced strategies employed using conventional IHD were found to be less than satisfactory when applied to the critically ill patient. As a result of refinements to the original technique changes in the way contemporary IHD is now performed on patients in the ICU has improved the delivery and tolerance of this approach to RRT (Ricci & Ronco, 2008). The technique is delivered on an alternative-day schedule or if necessary changed to daily treatments. Each session is operated by a specialist dialysis nurse usually lasting for three to four hours under the supervision of a nephrologist. The dialysis machine manufactures dialysate when filtered tap water is combined with electrolytes to form a bicarbonate-based solution (Hoenich, Ronco, & Levin, 2006). A dialysate flow rate is set between 200ml and 300ml per min and may be

increased as tolerated to a maximum rate of 800ml per min. The blood flow through the extracorporeal circuit can start from 200ml per min and gradually increased to run at a rate of 300ml per min (O'Reilly & Tolwani, 2005). The use of haemodialysers promote the removal of solutes by diffusion with the loss of fluid and solutes by convection also possible following a change from cellulose-based low-flux membranes to the selection of high-flux synthetic membranes associated with contemporary IHD.

Continuous Renal Replacement Therapy

An alternative approach for the management of severe ARF in the critically ill patient uses CRRT to provide a more gradual approach to fluid and solute removal (Ronco, Bellomo, & Ricci, 2001). In contrast to IHD the technique of CRRT is able to be performed by the critical care nurse under the supervision of the intensive care specialist. A semi-automated machine operated by the critical care nurse monitors blood flow and the delivery of packaged dialysate solutions and/or replacement fluids. Haemofilters are generally used in CRRT and comprise of high-flux synthetic membranes which are more permeable to water. Increased hydraulic permeability of the membrane allows solute clearance by convection and the amount of ultrafiltrate produced during haemofiltration is greater in comparison to haemodialysis, since a larger volume of fluid is able to be filtered through the membrane. The scheduling of treatment using CRRT is set over 24hr with a comparatively slower blood flow rate than IHD of 150 to 200ml per min and a dialysate flow of 17 to 40ml per min when a diffusive treatment mode is used (O'Reilly & Tolwani, 2005), or an ultrafiltrate volume of 20 to 45ml per kg per hr for a convective treatment mode operating at a similar rate of blood flow (Ronco, et al., 2000). Although these settings for both treatment modes are described in the literature the decision on parameters has occurred by general agreement rather than substantial evidence of effectiveness in the management of renal insufficiency.

History and Development.

The introduction of haemodialysis as a life-saving treatment for ESRD coincided with the development of an alternative method of Renal Replacement Therapy (RRT) using ultrafiltration. Instead of diffusion as the principle mechanism of solute removal in the management of ESRD Henderson and associates (1967) described a RRT that relied on convection to remove solutes from azotemic patients. This occurred during a period where understanding of mechanisms in solute transport had improved along with

the development of synthetic polymers to produce membranes which were more permeable to water. The technique at the time was referred to as 'diafiltration' a term used to describe when blood was forced through an extracorporeal circuit and filtered using a highly permeable membrane to generate large volumes of an ultrafiltrate solution (Henderson, Ford, Colton, Bluemle, & Bixler, 1970). The composition of the ultrafiltrate had the same solute concentration as 'uremic' plasma water. At the same time as the plasma water was lost in the ultrafiltrate a replacement solution was added to the systemic blood supply which had a similar composition to normal urea-free plasma water.

The original name of diafiltration to describe ultrafiltration as a RRT was later replaced with the term haemodiafiltration. The technique was used as an intermittent 'pumped' therapy and was put forward as a possible alternative to IHD for the management of ARF or ESRD (Henderson, Livoti, Ford, Kelly, & Lysaght, 1973). Technical problems associated with accuracy in replacing large volumes of ultrafiltrate and the cost of sterile replacement fluid prevented the widespread use of the technique in preference for the cheaper alternative of IHD.

Interest in using ultrafiltration as RRT was rekindled by Dr Peter Kramer, a nephrologist in Gottingen, Germany. Using a technique which placed a haemofilter between an arterial and venous blood line, connecting the femoral artery with the venous artery, the action of the heart alone rather than an external pump was shown to be sufficient to produce ultrafiltrate. Continuous Arterio-Venous Haemofiltration (CAVH) was first described by Kramer, Wigger, Rieger, Matthaei and Scheler (1977) for the treatment of diuretic-resistant oedema in patients with severe heart failure. The continuous approach to RRT was seen as being more favourable than conventional IHD for the management of critically ill patients with ARF due to a reduction in haemodynamic instability when compared with the alternative approach and the opportunity the technique gave in the removal and control of excess fluid volume (Kramer et al., 1980). To make the most of the technique's ability to remove solutes by convection as well as excess plasma water against the background of improved haemodynamic stability, clinical experience of CRRT in the ICU was first gained using the original and simplest form of the technique CAVH (Kramer et al., 1982; Lauer et al., 1983; Olbricht, Mueller, Schurek, & Stolte, 1982). In CAVH the femoral artery and vein were cannulated and blood passed 'spontaneously' through the haemofilter under the influence of arterial blood pressure. Although the technique offered the critically ill

patient increased regulation of excess fluid volume without the problem of haemodynamic instability a number of weaknesses in the approach when compared with conventional IHD resulted in the implementation of several improvements to the original technique.

The inadequacy of CAVH in achieving high and reliable solute clearance led to the addition of a dialytic component and the method of Continuous Arterio-Venous Haemodialysis (CAVHD) (Geronemus & Schneider, 1984). After this modification to the basic CAVH circuit solute clearance was improved and patients who were hypercatabolic could now be managed without resorting to IHD. Similar to the setup used for conventional IHD the efficiency of CAVHD to remove urea and creatinine was increased when the direction of dialysate through the haemodialyser was circulated in the opposite direction to blood flow (Davenport, Will, & Davison, 1990b).

The next major innovation saw the incorporation of pump technology for the control of blood flow, with the use of double lumen central venous access and the techniques of continuous veno-venous haemofiltration, continuous veno-venous haemodialysis (CVVHD) and CVVHdf (Kirby & Davenport, 1996). These techniques did not require cannulation of the artery which carries the potential risk of rapid blood loss should accidental disconnection occur. Instead the veno-venous techniques took advantage of developments in the area of chronic dialysis to utilise new central venous catheter technology. The pump driven veno-venous system also resolved the limitation imposed by the original system of reliance solely on arterial blood pressure to drive blood flow. In the critically ill patient blood pressure is not always reliable due patient haemodynamic instability with the tendency of the extracorporeal circuit to clot when blood flow is reduced (Boyle & Baldwin, 2010).

The introduction of veno-venous pump technology increased the efficiency of CRRT. As well as reducing the incidence of premature blood clotting due to the ability to sustain a higher rate of blood flow irrespective of the patient's blood pressure, larger volumes of ultrafiltrate could now be achieved with good solute clearance of urea and creatinine. The effectiveness of using both approaches have been compared in a RCT (Storck, Hartl, Zimmerer, & Inthorn, 1991). Patients with severe ARF following surgery were assigned to receive either pump-driven CVVH or spontaneous CAVH. The process of randomisation was restricted by the limited availability at the institution of veno-venous pump technology which led to all patients being assigned CVVH unless

the equipment was already being used in the treatment of another patient. As a consequence of fewer cases than expected requiring treatment simultaneously the distribution of patients who received CVVH as opposed to CAVH was unevenly distributed (68 versus 48). Despite the uneven distribution which had occurred patient characteristics and severity of illness were similar among the two treatment groups. The authors observed survival of patients to hospital discharge who had received CVVH was significantly higher than patients who were treated with CAVH (20[29.4%] versus 6[12.5%]; P-value < 0.05). A correlation between patients who had survived and the volume of ultrafiltration produced using CVVH compared with CAVH was also shown to be statistically significant (15.7[13.6-17.8] versus 7.0[6.6-7.4] L per day; P-value > 0.05).

Contemporary Treatment Modes.

The shortcomings of the original CAVH technique proposed by Kramer and associates (1977) to manage severe ARF in the critically ill patient led Bellomo (1996) to conclude CAVH could no longer be a treatment modality appropriate to use in organisations where veno-venous pump technology was available. Although improvements in technology have increased the effectiveness of the approach when compared with the original technique, the introduction of veno-venous CRRT has to some extent reversed the simplicity viewed at the time of its inception as an advantage, to the development instead of treatments which are more complex to manage. Since blood flow using veno-venous CRRT is determined by an external source (blood pump) rather than blood pressure a double lumen catheter is required to be inserted into a central vein (subclavian, jugular or femoral). Once placed into the correct position, blood is able to be drawn through the 'outflow' lumen of the catheter. The motorised pump circulates the blood along the extracorporeal circuit and enters the haemofilter or haemodialyser before the blood is returned to the patient through the 'inflow' lumen of the catheter. The technology surrounding veno-venous CRRT delivery systems initially used makeshift devices adapted from hardware originally developed for the delivery of dialysis in the management of patients with ESRD (Cruz et al., 2009). This allowed the technique to operate at blood flow speeds which were much higher than previously achieved using CAVH but required alterations to the original design of the circuit and the introduction of pressure monitoring to record blood flow through the circuit. Other changes to the original CAVH circuit included the use of a venous bubble chamber to allow the removal of trapped air from the veno-venous blood line. Operational

differences also allowed veno-venous CRRT to achieve higher ultrafiltration volumes but increased the potential for fluid balance errors when this required the exchange of larger volumes of fluid.

The use of makeshift devices affected the performance of the technique due to the lack of integration between equipment not specifically designed for the purpose of veno-venous CRRT. One example of how performance was influenced by the lack of integration with different pieces of equipment was the practice of using infusion pumps that were external to other parts of the device. A study investigating the use of infusion pumps to regulate the rate of dialysate exchanged and the volume of ultrafiltrate produced during CVVHD was shown to be open to potential errors in the accuracy of the infusion pump to maintain the correct fluid balance required (Roberts & Winney, 1992). To overcome the problem the next generation of CRRT machines in use today are purpose-built appliances. These machines are designed specifically to meet the requirements of the technique which has semi-automated the monitoring of the extracorporeal circuit and the management of large volumes of fluid to provide an integrated system which is easier for the critical care nurse to manage (Ricci et al., 2004). As shown in Figure 2.1 there are four basic veno-venous options under the 'continuous' classification of extracorporeal therapies. They include slow continuous ultrafiltration (SCUF), CVVH, CVVHD and CVVHdf. Each approach differs in operational complexity and in performance of solute and fluid control (Ronco, Brendolan, & Bellomo, 2001).

Slow Continuous Ultrafiltration is a technique employed to achieve volume control in patients who have severe fluid overload (Ronco, Ricci, Bellomo, & Bedogni, 2001). The technique takes advantage of hydrostatic pressure to remove excess fluid by ultrafiltration using a haemofilter which is highly permeable to water. A number of conditions such as heart failure reduce the capacity of the kidneys to remove the accumulation of excess fluid. The main difference between SCUF and other CRRTs which utilise ultrafiltration is the omission of replacement fluid with the removal of excess fluid the primary objective of SCUF rather than the clearance of solutes for the purposes of biochemical control. Patients diagnosed with decompensated heart failure are often appropriate candidates for SCUF when conservative measures to restrict fluid intake is unsuccessful and pharmacologic interventions such as diuretic therapy and vasodilating agents are ineffective. The therapeutic benefits of SCUF in these patients include the modulation of the renin-angiotensin-aldosterone-system with the removal of

sodium causing a decrease in total body fluid and a subsequent reduction in preload volume (Schrier, 2006). The use of SCUF in patients with heart failure who were hypervolaemic was shown to be more effective in the removal of excess fluid than the administration of intravenous diuretic therapy (Costanzo et al., 2007). Patients who were randomised to receive SCUF had greater fluid and weight loss at 48hr when compared with patients who instead were treated using a loop diuretic (fluid loss 4.6L SD \pm 2.6 versus 3.3L SD \pm 2.6, P-value = 0.001 and weight loss 5.0kg SD \pm 3.1 versus 3.1kg SD \pm 3.5, P-value = 0.001). The removal of myocardial depressant factors and the release of other toxic substances is also suggested as a possible explanation for the observed improvement in cardiac function (Coraim & Wolner, 1995). An illustration of SCUF is shown in Figure 2.6.

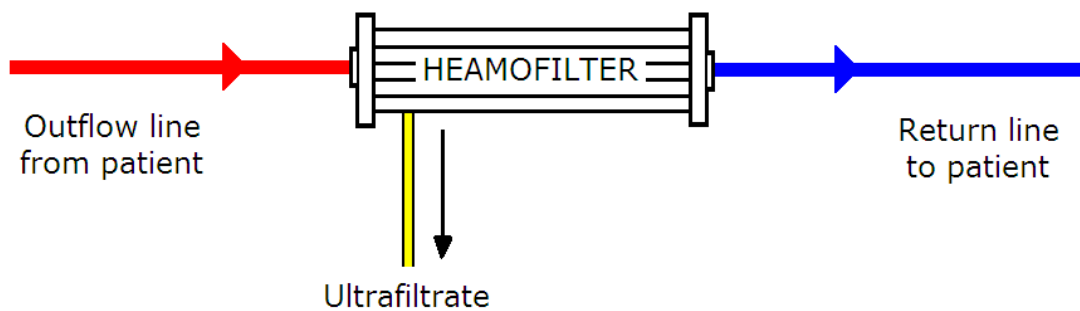

Figure 2.6. An illustration of slow continuous ultrafiltration.

Continuous Veno-Venous Haemofiltration refers to the technique which uses the movement of plasma water by ultrafiltration to remove solutes by convection through a semi-permeable membrane (S. John & Eckardt, 2007). Depending upon the volume of plasma water which passes through the haemofilter and the sieving co-efficient of the semi-permeable membrane, biochemical control of small molecules and the modulation of larger septic mediator molecules is able to be achieved in conjunction with the removal of excess fluid. The ultrafiltrate that is produced flows from the blood compartment across the membrane and travels along the outer side of the fluid compartment before it is drained away. A replacement solution is delivered into the circuit to compensate for excessive removal of plasma water and to maintain the body's correct electrolyte balance. An illustration of CVVH is shown in Figure 2.7.

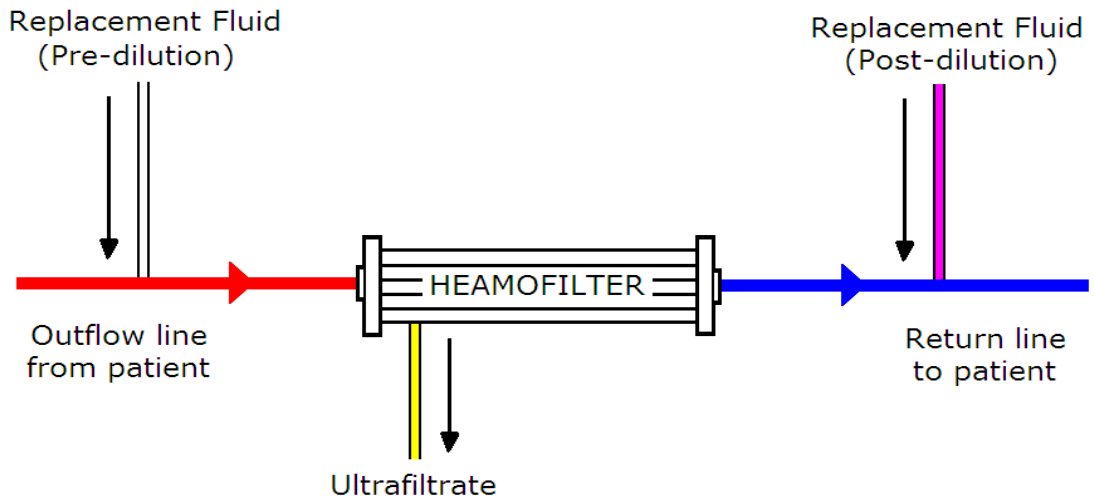

Figure 2.7. An illustration of continuous veno-venous haemofiltration.

Continuous Venovenous Haemodialysis achieves solute clearance by diffusion (Dirkes & Hodge, 2007). A dialysate solution runs in the opposite direction to blood flow outside the blood compartment of the haemodialyser. The exchange of solutes across the semi-permeable membrane occurs when the concentration gradient between the blood and fluid compartments are different in favour of the movement of smaller molecules. The passive movement of solutes across the membrane is drained away from the dialyser as 'spent' dialysate. Very little plasma fluid is lost during diffusion and the requirement for a replacement solution is generally not necessary. An illustration of CVVHD is shown in Figure 2.8.

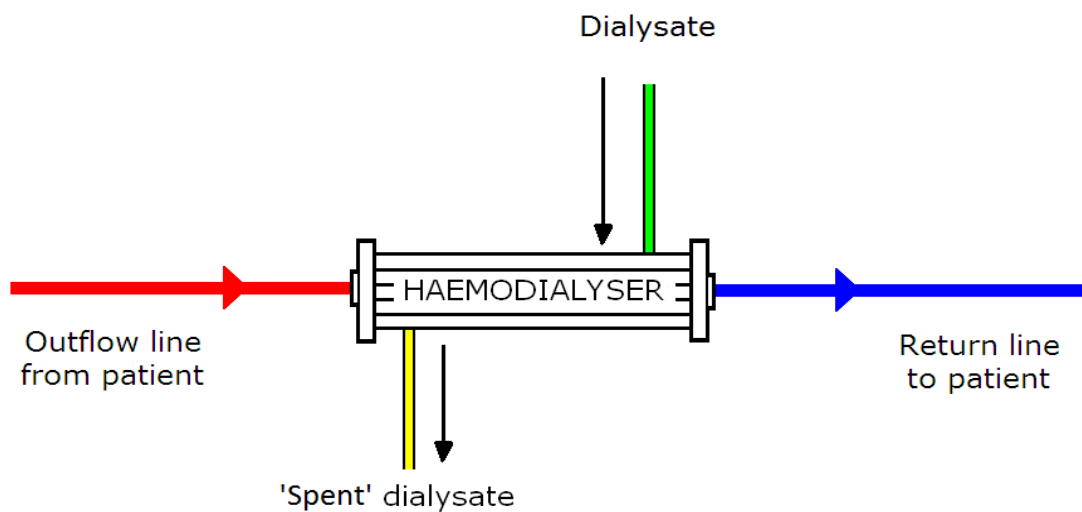

Figure 2.8. An illustration of continuous veno-venous haemodialysis.

The technique of CVVHDF is similar to CVVH but modified by the addition of dialysis to combine diffusion with convection in the removal of solutes and excess fluid (Dirkes & Hodge, 2007). Circulating in the opposite direction to blood flow the dialysate solution passes along the outer side of the semi-permeable membrane and merges with the ultrafiltrate produced from the movement of plasma water as blood passes through the haemofilter or haemodialyser. The inclusion of a dialysate solution facilitates the process of diffusion and the administration of a replacement solution exchanges the plasma fluid that is lost during convection. Small and large molecules concentrated in the patient's blood move across the membrane either due to a lower solute concentration found in the dialysate solution or as solvent drag; a consequence of plasma water removal. A schematic illustration of CVVHDF is shown in Figure 2.9.

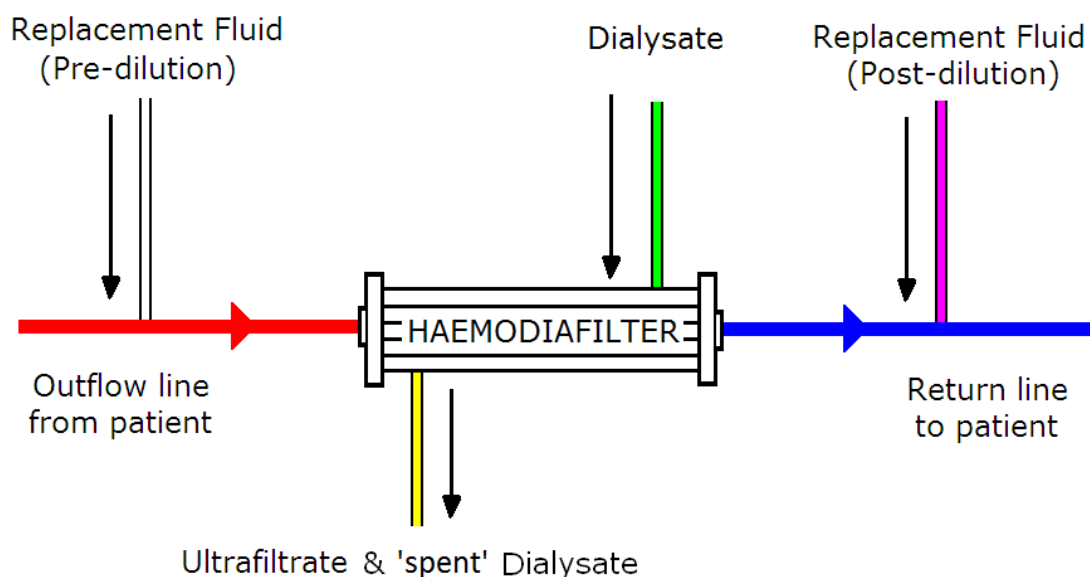

Figure 2.9. An illustration of continuous veno-venous haemodiafiltration.

The question of whether biochemical control in the management of ARF is influenced by the choice of CRRT mode selected and the impact of diffusion-based versus convection-based techniques has on patient outcomes is the subject of discussion in the literature. Despite a number of studies attempting to address this issue the preferred method of solute removal during CRRT has yet to be established. The capacity of CRRT to remove solutes of different molecular weight as a reason for selecting a specific treatment mode was investigated during a prospective crossover

study (Ricci, Ronco, Bachetoni, et al., 2006). An evaluation of small and middle-size solute clearance using a dose prescription of 35ml per kg per hr and polyacrylonitrile membranes found the capacity of both CVVHD and CVVH was the same up to 48 hours after treatment had commenced, but a non- significant rise in middle size solute removal (β_2 microglobulin) occurred with CVVH after 72hr. Some intensive care specialists prefer convective treatment modalities like CVVH when there is evidence to suggest longer sessions of CVVHD are required to achieve equivalent clearance of middle-size molecules when solute removal is by diffusion. The results of a single centre RCT by Ronco and associates (2000) demonstrated survival in patients whose ARF was associated with sepsis improved when higher compared to lower ultrafiltration rates achieved greater convective clearance. In a retrospective controlled study the techniques of CVVH and CVVHdf were compared based on the ability of each mode to achieve azotemic stability (Morimatsu, Uchino, Bellomo, & Ronco, 2002). Despite attention given to ensure the treatment dose ordered was the same between both modalities the study found mean urea and creatinine levels were significantly lower during CVVH than those recorded using CVVHdf (mean urea levels 16.7mmol/L $SD\pm 7.8$ for CVVH versus 22.3mmol/L $SD\pm 9.0$ for CVVHdf [P-value < 0.0001] and mean creatinine levels 211 μ mol/L $SD\pm 103$ for CVVH versus 302 μ mol/L $SD\pm 167$ for CVVHdf [P-value < 0.0001]). The value of CVVHdf as a treatment mode uses both diffusion and convection to maximise the range of molecules which are cleared. Adding a dialysis dose to haemofiltration was shown in one RCT to increase the survival among critically ill patients with ARF (Saudan, et al., 2006). Although the recovery rate of renal function was not affected by the type of RRT, the mortality rate of patients treated with CVVHdf was significantly lower than patients who received CVVH. The survival of patients at 28 days was 59% for CVVHdf compared with 39% for CVVH (P-value = 0.03). A difference of 20% provides strong evidence in support of change away from CVVH in favour of CVVHdf, but randomisation only involved 206 patients and the findings of the study possibly weakened by the outcome of only a few patients altering the estimation of significance observed.

Intermittent versus Continuous Renal Replacement Therapy

Over the course of three decades CRRT has been promoted by its supporters as superior to conventional IHD for support of ARF in the ICU (Ronco & Bellomo, 2007). Although the technique has received acceptance as an alternative treatment strategy and in some instances has superseded the use of IHD, others do not support the widespread

use of CRRT when there is insufficient evidence of a significant improvement in patient outcomes (Himmelfarb, 2007). Several important differences in the operational characteristics of conventional IHD and CRRT along with appropriately powered outcome studies continue to be the subject of comparison in the literature. In efforts to determine the most appropriate form of RRT to treat the critically ill patient the principal elements of establishing superiority over the alternative technique should include studies which demonstrate evidence of an improvement in patient outcomes, or is shown to be a more effective treatment, or the incidence of complications is reported to be lower.

Effect on mortality and recovery of renal function

The underlying cause of disease and illness severity has an overwhelming effect on patient survival more so than supportive measures such as RRT. When attempts are made to investigate differences of patient outcomes using conventional IHD versus CRRT, several important aspects in the design of the study need to be overcome in order to compare the techniques. Comparisons made from retrospective studies are unreliable if historical controls are used which do not take into account confounding variables such as outdated protocols that are no longer practiced. When prospective studies are undertaken and patients are unable to be treated once randomised to receive a specific mode, or an attempt is made to avoid adverse events from occurring, or the severity in one group of patients is greater in comparison to the other group, the validity of differences in patient outcomes is skewed in favour of the technique with the least number of reported complications. A number of retrospective and prospective studies have sought to resolve this issue with varying degrees of success (Mehta et al., 2001; Uehlinger et al., 2005; van Bommel et al., 1995; Vinsonneau et al., 2006).

In a meta-analysis of mainly non-randomised studies no significant difference in patient survival using CRRT over IHD was observed (Kellum et al., 2002). After the authors made adjustments to compensate for differences in the quality of each study and severity of illness they did show patients treated with CRRT instead of conventional IHD had a lower mortality rate (relative risk [RR] 0.72, 95% CI 0.60-0.87, P-value < 0.01). When more randomised trials were included in a second meta-analysis the findings were not replicated and no significant variation in mortality was observed (RR 0.96, 95% CI 0.85-1.08, P-value = 0.50) (Tonelli, et al., 2002). A limitation of the meta-analysis undertaken by Kellum (2002) is the systematic review only looked at patient mortality and did not investigate the degree of renal recovery when IHD and CRRT

were compared. When this was considered in the meta-analysis completed by Tonelli (2002) although reported as not being statistically significant, patients treated with CRRT compared with IHD were observed to have a reduced risk of developing ESRD and dialysis dependency (RR 1.19, 95% CI 0.62-2.27, P-value = 0.06). Several retrospective, non-randomised studies undertaken since the two meta-analyses were conducted have shown a benefit in patients who received CRRT as opposed to those patients treated with IHD in the recovery of renal function (Bell, Granath, Schon, Ekblom, & Claes-Roland, 2007; Jacka, Ivancinova, & Gibbney, 2005; Waldrop et al., 2005). A meta-analysis undertaken more recently by Bagshaw and associates (2008) reported similar findings as in the previous meta-analysis undertaken by Tonelli (2002) with no significant difference observed between CRRT and IHD in mortality (odds ratio, 0.99; 95% CI, 0.78-1.26, P-value = 0.93; $I^2 = 11\%$; nine trials, n=1,403) or return of renal function (odds ratio, 0.76; 95% CI, 0.28-2.07, P-value = 0.59; $I^2 = 0\%$; four trials, n = 306). As occurred in the two previous meta-analyses the authors' encountered difficulties in undertaking the systematic review due to the limited number of studies which were of sufficient quality to answer the question accurately. Studies which have attempted to address the issue of whether differences in technique between CRRT and conventional IHD impact upon mortality and recovery of renal function are summarised in Table 2.1.

Effectiveness of Both Approaches

The effectiveness of CRRT or conventional IHD to manage ARF in the critically ill patient can be evaluated on several performance indicators. These include the ability of each technique to restore electrolyte and acid-base balance and to excrete metabolic waste products, to minimise the complexity of dose adjustment caused by excessive drug clearance, to remove excess fluid volume and allow adequate nutrition, to clear inflammatory mediators and to operate at a price which is affordable.

Solute control and restoration of acid-base balance.

Solute control of small molecules which are easily diffusible can be corrected in a much shorter time using conventional IHD than with CRRT and pure haemofiltration. To treat serum potassium level of 6mmol per L, an ultrafiltration rate of 2L per hour at a flow rate of 200ml per min will remove 12mmol per hour. When this is compared with a dialysate potassium concentration of 1 mmol per L operating at 500ml per minute using a similar rate of blood flow, over 60mmol of potassium is removed after only an

hour of conventional IHD (Lameire, van Biesen, van Holder, & Colardyn, 1998). The development of electrolyte disturbances, acid-base imbalances or drug intoxications may take up to a day to resolve with CRRT whereas using IHD they can be corrected in a matter of hours.

The rapid removal of solutes using conventional IHD is not always necessary in the management of severe ARF and the technique can be contraindicated in favour of CRRT. The use of this technique in patients with raised intracranial pressure (ICP) allows the gradual removal of solutes to avoid the development of cerebral oedema caused by plasma hypo-osmolality. Patients with hepatic as well as renal failure at risk of developing or exacerbating existing cerebral oedema, were observed to have a higher incidence of raised ICP when treated with intermittent haemofiltration (36 episodes ICP > 20mmHg) compared to those patients who received CAVH or CAVHD (16 episodes ICP > 20mmHg, P-value > 0.01) (Davenport, Will, & Davison, 1991). A reduction in cerebral oedema was also the subject of a case report when CRRT was used in the management of traumatic brain injury after aggressive crystalloid fluid resuscitation had led to the development of hypervolaemia (Fletcher, Bergman, Feucht, & Blostein, 2009). The authors observed ICP measurements after 12 hours of treatment had decreased to below 20mmHg compared with an average of 35mmHg previously recorded before initiation of treatment.

Table 2.1:

A summary of studies comparing CRRT with IHD on mortality and recovery of renal function included in narrative review

Citation	Setting	Research Design	Sample	Intervention	Method	Outcomes	Methodological Quality
Bell et al. (2007).	32 ICUs, Sweden.	Retrospective cohort study 1995 to 2004.	2,202 adult patients with ARF. Patients with pre-existing end-stage renal disease and dependent on dialysis excluded.	None.	Information collected on start date and mode of RRT with subsequent follow-up of renal function of surviving patients.	No significant difference between IHD and CRRT on 90 day mortality. Among 90 day survivors proportion of CRRT patients dependent on dialysis significantly lower.	Large controlled retrospective study.
Jacka et al. (2005).	Medicosurgical ICU, Canada.	Single-centre retrospective study.	93 adult patients with ARF (65 underwent CVVHDF and 28 IHD).	None.	Demographic and physiological information reviewed.	Return of renal function significantly higher in patients who received CVVHDF.	Small retrospective study.

Table 2.1(Cont'd):

Citation	Setting	Research Design	Sample	Intervention	Method	Outcomes	Methodological Quality
Mehta et al. (2001).	4 ICUs, America.	Multi-centre, randomised, controlled trial.	166 adult patients with ARF randomised. 84 underwent CRRT and 82 IHD.	Patients prospectively assigned to receive IHD or CRRT.	Length of stay, recovery of renal function and patient survival measured at 28 days.	After adjustments made to severity of illness no significant difference in mortality and return of renal function observed.	More severely ill patients assigned to CRRT than IHD which may have skewed results.
Uehlinger et al. (2005).	Medicosurgical ICU, Switzerland .	Single-centre randomised, controlled trial.	191 patients required RRT with 125 patients randomised. No patient escaped randomisation for medical reasons. 70 received CVVHDF and 55 IHD.	Randomisation designed to overcome differences in availability of devices to prevent either technique being under represented.	Patient survival, length of stay and return of renal function were measured.	No significant difference observed in survival or recovery of renal function.	Well designed rigorous study.

Table 2.1(Cont'd):

Citation	Setting	Research Design	Sample	Intervention	Method	Outcomes	Methodological Quality
van Bommel et al. (1995).	Surgical ICU, Netherlands.	Single-centre retrospective study.	94 adult patients, 34 received IHD and 60 CAVHDF.	None.	Demographic and physiological information collected.	No significant difference in patient survival.	Comparison possibly flawed due to differences in membrane biocompatibility.
Vinsonneau et al. (2006).	21 medical ICUs, France.	Multi-centre randomised, controlled study.	360 adult patients with multi-organ failure randomised, 176 assigned to CRRT and 184 IHD. Patients with chronic renal insufficiency excluded.	Patient survival verified at 28 days, 60 days and 90 days. Time to recovery of renal function, length of ICU and hospital stay, and adverse events measured.	Both treatments used similar membranes and bicarbonate-based dialysate solutions.	No significant difference observed in patient survival at 28 days, 60 days or 90 days. The recovery of renal function did not differ significantly nor duration of ICU and hospital stay. The occurrence of adverse events was reported equally between the two groups.	Randomisation was successful with satisfactory adherence to protocols. Specific interventions designed to improve haemodynamic tolerance of patients assigned to IHD disadvantaged CRRT.

Urea is a water-soluble compound which accumulates as a by-product of protein catabolism and is used as a marker to identify other toxic compounds when renal function is compromised (Dhondt, van Holder, van Biesen, & Lameire, 2000). Uremic toxins are removed during RRT by diffusion and/or convection and the response to treatment monitored by measuring the degree of BUN manipulation or azotemia control which is able to be achieved. A number of studies have shown the survival of patients with ARF is improved when the intensity of solute clearance is augmented irrespective of whether this has been achieved using continuous or intermittent techniques (Paganini et al., 1996; Ronco, et al., 2000; Schiffl, et al., 2002). Consistent azotemic control is able to be maintained more easily during CRRT since there is a progressive removal of uremic toxins which is difficult to match using IHD where solute clearance occurs at periodic intervals. In a retrospective study the average BUN level taken from patients treated with CVVH was 24mmol per L compared to the average BUN level of 36mmol per L taken from patients who received conventional IHD (Swartz, Messana, Orzol, & Port, 1999). Although azotemic control during CRRT was shown to be superior compared to IHD, the advantage of maintaining lower concentrations of BUN with CRRT was not translated into an improvement in patient survival. A weakness of this study may have been in the design which allowed patients who had showed signs of deterioration to change treatment modality and as a result, a disproportionate number of the severely ill patients who had initially commenced IHD were subsequently treated using CRRT.

A frequent problem in the critically ill patient with ARF is the development of a metabolic acidosis which requires intervention to restore acid-base balance. This is able to be corrected quickly using IHD but sustained more effectively using CRRT due to the continuous supply of buffer contained within the dialysate solution and/or replacement fluid (Thomas & Harris, 2002). The interval between treatment schedules when patients are treated with IHD allows metabolic acidosis to redevelop and during the next treatment requires renewed correction. A significantly lower concentration of bicarbonate in arterial blood was observed in a retrospective report of patients treated with conventional IHD compared to patients who received CVVHDF (30.3% versus 17.7%, P-value = 0.0021) (Uchino, Bellomo, & Ronco, 2001). Studies which have attempted to address the issue of differences in solute control and restoration of acid-base balance between CRRT and conventional IHD are summarised in Table 2.2.

Drug clearance and dose adjustment.

The use of CRRT as opposed to conventional IHD can increase the complexity of drug therapy in the management of the critically ill patient (Bugge, 2004). Drugs administered to the patient may require the dose to be adjusted according to the mode of RRT selected. The majority of drugs have a molecular weight equal or below 500 Daltons with only a few greater than 1,500Da (Bugge, 2004). Conventional IHD limits the clearance of drugs by diffusion to substances with a low molecular weight in contrast to membranes used for CRRT which have a larger pore size offering no filtration barrier to drugs of a higher molecular weight (Bugge, 2004). The individual properties of drugs will also combine with the operational differences of conventional IHD and CRRT to influence the degree of clearance obtained. A drug that is heavily bound to circulating proteins is not easily cleared by diffusion and convection when compared with drugs which have limited protein binding. Drugs which have a large volume of distribution are more likely to be absorbed into body tissues and have a reduced concentration level in the bloodstream which can restrict the degree of clearance that is possible through the haemofilter or haemodialyser. The electrical charge of the drug will influence the ease of passage through the membrane with cationic drugs repelled and anionic drugs attracted when exposed to proteins retained on the blood side of the negatively charged membrane. Consideration should also be given to other properties of the drug with some clearance possible despite impaired kidney function or clearance achieved when metabolised by the liver. Although individual properties of drugs can impact on concentration levels in the body clearance of drugs is often greater using CRRT than conventional IHD (Bugge, 2004). Increased dose adjustment may be necessary to maintain adequate therapeutic levels, since the capacity to maintain drug concentration levels is more likely to be restored between treatment schedules once the session of conventional IHD is completed.

Table 2.2:

A summary of studies comparing CRRT with IHD on solute control and restoration of acid-base balance included in narrative review

Citation	Setting	Research Design	Sample	Intervention	Method	Outcomes	Methodological Quality
Swartz et al. (1999).	Medicosurgical ICU and non-ICU areas in single-site university hospital, America.	Retrospective study.	227 adult patients with ARF who required RRT for the first-time (91 treated with CVVH and 136 IHD).	None.	Analysis of demographic and clinical data.	Solute removal superior with CVVH in comparison to IHD. Patients who received CVVH had greater severity of illness and higher patient mortality.	The choice of RRT not controlled and open to bias by treating physician who may have had preference for a particular modality.

Table 2.2(Cont'd):

Citation	Setting	Research Design	Sample	Intervention	Method	Outcomes	Methodological Quality
Uchino et al. (2001).	Medicosurgical ICU, Australia.	Retrospective controlled study.	96 adult patients with ARF (47 treated with IHD and 49 CVVHDF).	None.	Demographic, clinical and biochemical data collected from patients who received IHD and examined over a period of three years followed by a similar review of patients who were treated with CVVHDF.	Significant difference found in the normalisation and maintenance of serum sodium and potassium and arterial bicarbonate concentrations in favour of CVVHDF.	Sufficient control placed on fluid and electrolyte management practices increase the reliability of the retrospective study to detect differences between each treatment modality.

Fluid regulation and nutrition.

The regulation of fluid volume is an important consideration in critically ill patients who run the risk of volume overload when renal insufficiency is associated with poor urinary output. The capacity of CRRT to regulate fluid volume when large volumes of fluid for drug infusions or blood products are required is a major advantage over conventional IHD (van Bommel, 1995). The removal of excess fluid and the maintenance of a negative fluid balance during CRRT has been shown to improve cardiac function in patients with congestive heart failure by the reduction of pre-and after-load fluid volume (Coraim & Wolner, 1995), and achieve superior pulmonary gas exchange when compared with the respiratory function of patients treated with conventional IHD (Bellomo, Farmer, Wright, Parkin, & Boyce, 1995). A summary of this study is provided in Table 2.3.

As nutrition is delivered in a liquid volume critically ill patients with ARF are exposed to the risk of relative malnutrition if fluid administration is restricted due to the development of oliguria (Leverve & Barnoud, 1998). During conventional IHD efforts to avoid overloading the patient with excess fluid volume between treatment schedules can result in sub-optimal nutrition. However, when using CRRT no restriction is placed on the delivery of high-calorie fluids. Excess fluid is able to be removed continuously each hour, with nutritional requirements adjusted periodically in order to match metabolic demands in the critically ill patient. Whilst a number of studies have shown patients who are catabolic are more likely to receive the required protein intake during CRRT (Bellomo et al., 1992; Mc Donald & Mehta, 1991), there is no evidence to suggest the augmentation in protein delivery when compared to conventional IHD is associated with improved patient outcomes.

Removal of inflammatory mediators.

Many critically ill patients develop ARF as a complication of sepsis (Klenzak & Himmelfarb, 2005). The effect of CRRT on promoting haemodynamic stability in septic patients leading to a reduction in the requirement for vasopressor support, not explained solely by improved cardiac function due to the removal of excess fluid, has been attributed to haemofiltration and the clearance of middle molecular weight molecules associated with the inflammatory process (Heering, Grabensee, & Brause, 2003). The improved haemodynamics observed during CRRT might also be explained by the extended duration blood is circulated outside of the body and the impact of mild

Table 2.3:

A summary of one study comparing CRRT and IHD on fluid regulation included in narrative review

Citation	Setting	Research Design	Sample	Intervention	Method	Outcomes	Methodological Quality
Bellomo et al. (1995).	Medico-surgical ICU, Australia.	Prospective controlled study followed by retrospective comparison.	87 consecutive patients with sepsis in prospective study and 83 patients admitted for sepsis in retrospective study.	Patients enrolled in prospective study were treated with CRRT and comparison made of differences in outcomes with patients who had been retrospectively treated with IHD.	Patients classified according to illness severity and number of organ failures. Information collected on biochemical, haematological and microbiological measurements.	Among patients who were treated with CRRT significant improvement in gas exchange occurred within the first 24hr of treatment.	Although historical controls included patients with similar illness severity, patients who received CRRT represented a contemporary cohort of patients and findings against IHD possibly biased.

hypothermia on increasing vascular tone. The capacity of CRRT to remove cytokines and other inflammatory mediators has been demonstrated to occur by convective clearance and in the adsorptive capacity of synthetic biocompatible membranes in several prospective studies on humans with septic shock (Bellomo, Tipping, & Boyce, 1993; Dahaba, Elawady, Rehak, & List, 2002; de Vriese et al., 1999; Heering et al., 1997; Klouche et al., 2002). The ability to remove molecules of a larger molecular weight by convection is reduced when low-flux non-biocompatible membranes most associated with conventional IHD are used which have a lower sieving coefficient not conducive to hydraulic permeability and a limited capacity to achieve solute clearance by adsorption (J. B. Ponikvar, et al., 2001). Although the use of standard CRRT has been shown to remove septic mediators the capacity to achieve a sustained reduction of inflammatory molecules has not been demonstrated in patients with sepsis (Cole et al., 2002). Since the generation of septic mediators occurs more rapidly than increases of urea a different approach using CRRT is suggested for sepsis compared with the method normally used for the management of ARF. Investigation of high-volume haemofiltration (HVHF) with an ultrafiltrate of 6L per hour was able to achieve a substantial reduction in the concentration of cytokines and other septic mediators incorporating a fluid exchange which otherwise would not normally be prescribed using standard CRRT (Cole et al., 2001). A different approach to improve the clearance of inflammatory mediators known as high-cutoff haemofiltration incorporates a membrane of increased permeability shown as being superior in the removal of specific cytokines (Morgera et al., 2006). The ability to moderate the inflammatory response as a result of severe infection is further improved when the capacity for membrane adsorption is increased by frequent circuit changes. The use of standard CRRT does not alone offer a strategy which has been shown to improve patient outcomes for the treatment of sepsis beyond that required in support of renal function. Only after changes are made to the approach normally used for ARF can the potential benefit of haemofiltration and adsorption when compared with conventional IHD in reducing the inflammatory response be adequately realised in patients with sepsis. More investigation is required to determine whether HVHF, the effects of high cutoff haemofiltration, and increased membrane adsorption lower the levels of inflammatory mediators in sufficient quantities to reduce the incidence of MOD and make a positive difference in patient survival.

Cost.

An important aspect of CRRT to be considered when choosing to employ this technique as opposed to conventional IHD is the cost associated with the initial purchase and use of specialist equipment (van Biesen, Vanholder, & Lameire, 2003). The purpose-built CRRT machines now available can only be used in the ICU and is a treatment option which increases the workload and responsibilities of the critical care nurse assigned to look after the patient. The requirement to purchase sterile bags of dialysate solutions and/or replacement fluid increase the operational expenditure associated with CRRT. The cost of CRRT was shown to be significantly higher when comparisons were made with conventional IHD (B. Manns, et al., 2003). A summary of this study is provided in Table 2.4. Other authors have reported only a marginal increase in expenditure between the two treatment modalities when the costs of replacing dialysis machines, water treatment systems and the requirement for a dialysis nurse associated with conventional IHD are taken into account (Bellomo & Ronco, 2000). The cost differential between the two treatment modes has now possibly changed in favour of conventional IHD following the recent introduction of more sophisticated CRRT machinery and expense associated with specialist dialysate and replacement fluid. Using the most expensive form of CRRT Farese and associates (2009) compared CVVHdf with the costs incurred when patients were randomised to receive conventional IHD. The initial outlay on equipment and maintenance costs estimated by the authors indicated CVVHdf was more expansive to operate than conventional IHD, plus the total cost of consumables including the price of sterile fluid bags versus treated drinking water was significantly higher when patients received CVVHdf compared to those patients managed by conventional IHD (P-value < 0.001). The approach used by Farese and associates (2009) provide for the present the most realistic cost comparison between CVVHdf and conventional IHD.

Complications using each approach

The incidence of complications associated with CRRT and conventional IHD in terms of haemodynamic stability, bleeding, and immobilisation are important factors to consider when choosing which mode is the most appropriate to manage the critically ill patient.

Table 2.4:

A summary of one study comparing the cost between CRRT and IHD included in narrative review

Citation	Setting	Research Design	Sample	Intervention	Method	Outcomes	Methodological Quality
B. Manns et al. (2003).	Medico-surgical ICUs, Canada.	Retrospective cohort study.	261 patients.	None.	Cost of CRRT calculated daily and per session for IHD.	CRRT more expensive than IHD.	Variations in patient management practices between hospitals might have caused differences in the usage of resources.

Haemodynamic stability.

A major complication of conventional IHD in the critically ill patient is the development of hypotension. Intravascular hypovolaemia can arise when there is a rapid removal of fluid to remove excess volume within the time allowed for the procedure (Abuclo, Shemin, & Chazan, 1993). Acetate in dialysis fluid as a buffering agent has now been replaced with bicarbonate-based solutions for acutely ill patients in recognition of the hypotensive effect which was associated with its use in conventional IHD (Leunissen & van Hooff, 1988). The development of adverse biological effects due to blood-membrane interactions can also produce episodes of hypotension during IHD when non-biocompatible haemodialysers are used (Hakim, 1993).

The incidence of hypotension due to haemodynamic instability can be detrimental in patients with ARF causing tubular ischaemia and a temporary loss of pressure-flow autoregulation (Bellomo & Ronco, 1999). If subsequent reductions in blood pressure take place the loss of regulatory control in glomerular capillary perfusion can cause delay in the recovery of kidney function and in the improvement of other compromised organs (Bellomo & Ronco, 1999; Conger, 1990; M. Manns, Sigler, & Teehan, 1997). This recognition of the intolerance of some critically ill patients to withstand the adverse haemodynamic effects of conventional IHD was a factor which led to the development of CRRT (Kramer, et al., 1980).

In a randomised cross-over study the incidence of hypotension during CAVH was compared with conventional IHD (Misset et al., 1996). Whilst the authors observed no significant difference in the highest and lowest MAP measurements between the two techniques (46mmHg SD \pm 21 for CAVH versus 48mmHg SD \pm 14 for IHD, P-value = 0.73), a number of weaknesses in the design of the study suggest caution should be exercised on assessing the reliability of these results. When compared with invasive monitoring techniques the use of non-invasive devices throughout the study was not as sensitive to changes in blood pressure during episodes of hypotension, and the reporting of derived rather than raw data introduced imprecise comparisons of variability in MAP measurements. In a more recent RCT by Augustine and associates (2004) greater haemodynamic stability occurred with CRRT when measurements of MAP were recorded continuously using invasive monitoring techniques. Patients assigned to IHD had a significant decrease in MAP (77.6mmHg SD \pm 12.9 baseline versus 75.0mmHg SD \pm 13.8 treatment, P-value = 0.04) compared with a MAP which remained unchanged

in patients who received CVVHD 76.8mmHg $SD\pm 7.8$ baseline versus 77.4mmHg $SD\pm 8.1$ treatment, P-value = not significant [NS]). This correlated with a higher incidence of patients requiring an increase in vasoactive agents during IHD compared with a lower incidence in patients who received CVVHD (40% versus 12.5%, P-value = 0.005). Although conventional IHD is associated with a fall in MAP a retrospective study observed the haemodynamic tolerance of critically ill patients was improved, when the duration of the treatment session was increased and a drop in the rate of fluid removal reduced the incidence of hypotension caused by the sudden loss of circulatory volume (Schortgen et al., 2000). Studies which have compared haemodynamic stability between the two techniques are summarised in Table 2.5.

Bleeding.

The critically ill patient who has a recent history of trauma or coagulation disorders is at risk of bleeding when anticoagulants are used to perform extracorporeal RRT (P. Y. Martin, Chevrolet, Suter, & Favre, 1994; van de Wetering et al., 1996; Ward & Mehta, 1993). In order to reduce premature clotting and extend circuit life the performance of CRRT more so than IHD requires some form of circuit anticoagulation. Since conventional IHD is only required to operate over several hours when anticoagulants are used with CRRT, the risk of bleeding is increased due to the effects of systemic anticoagulation. A decision to operate CRRT without anticoagulation due to severe coagulopathy or the use of regional anticoagulation following surgery are viable alternatives for patients who are at high risk of bleeding (Morabito et al., 2003; Palsson & Niles, 1999; Uchino, Fealy, Baldwin, Morimatsu, & Bellomo, 2004). Similarly the maintenance of circuit life using conventional IHD is not as important when compared with CRRT and minimal or no anticoagulation may only be required for completion of the treatment schedule. The contraindication of anticoagulatory agents was a reason given why during a RCT patients initially assigned to CRRT were switched and instead received IHD (Vinsonneau, et al., 2006).

Immobilisation.

The imposition of bed rest can expose the critically ill patient to several days or weeks of immobilisation. Many survivors of severe ARF and the dysfunction of other organs suffer complications in the ICU as a result of prolonged periods of inactivity. The adverse effects of enforced bed rest include muscle weakness and atrophy, systemic inflammation and inflammatory conditions, metabolic disturbances characterised by

Table 2.5:

A summary of studies comparing CRRT and IHD on haemodynamic stability included in narrative review

Citation	Setting	Research Design	Sample	Intervention	Method	Outcomes	Methodological Quality
Augustine et al. (2004).	Medico-surgical ICU, America.	Single-centre randomised controlled trial.	105 patients required RRT, 40 randomised to CVVHD and 40 IHD. No patient was excluded due to illness severity or haemodynamic instability.	Patients classified into high and low-risk groups.	Changes in MAP were measured during first 72 hr of RRT.	After 72hr MAP of patients treated with IHD significantly lower than MAP of patients who received CVVHD. Vaso-pressor requirements significantly higher in patients who received IHD.	Study not adequately powered to detect relationship between differences in haemodynamic stability and degree of renal recovery.
Misset et al. (1996).	Medico-surgical ICU, France.	Randomised cross-over controlled trial.	39 adult patients (27 completed the study).	24hr period of CAVH and a 24hr period encompassing a 4hr IHD treatment.	Patients randomised to receive both treatments separated by a 24hr wash-out period.	No significant difference in mean arterial pressure measurement or vasopressor requirements.	Small prospective study. Non-invasive rather than invasive monitoring of blood pressure and use of derived instead of raw data introduced inaccuracies when haemodynamic differences were compared.

increased blood sugar levels, venous stasis and the risk of blood clots, joint contractures leading to reduced range of movement, and the development of pressure sores (Brower, 2009). The ability to increase physical activity safely may not be considered feasible in the critically ill patient but a variety of studies have shown the benefits of early mobilisation (Morris et al., 2008; Schweickert et al., 2009).

To achieve a similar degree of solute removal and the desired level of azotemic control the technique of CRRT is required to operate uninterrupted for a much longer duration than the treatment schedules normally associated with conventional IHD. Using both approaches will place restrictions on patient mobility but compared with IHD the limitations on physical activity are imposed for a greater length of time during CRRT. The opportunity to assist the patient who has been receiving CRRT out of bed for early mobilisation may be possible before the patient is attached to the circuit. A number of situations require elective discontinuation of the circuit and CRRT temporarily suspended to allow the transportation of the patient outside the ICU for radiographic scanning, surgery or other procedures. On each occasion the patient is no longer attached to the CRRT machine, important dialysis and/or ultrafiltration time is lost which can reduce the effectiveness of the treatment particularly if the patient is absent from the ICU for a long period of time, or the preparation of a new circuit causes a delay in the recommencement of treatment. The ability of CVVH to stabilise urea plasma concentration was shown to be affected when actual delivered treatment time within a 24hr cycle was less than 16hr (Uchino, et al., 2003a).

Hybrid Therapies

A number of recently undertaken international surveys have reported the emergence of 'hybrid therapies' as a form of RRT now used in some ICUs for the management of ARF (Overberger, et al., 2007; Ricci, Ronco, D'amico, et al., 2006). The use of Slow, Low-efficiency Daily Dialysis/Extended Daily Dialysis (SLEDD/EDD) or Slow, Low-efficiency Daily Diafiltration/Extended Daily Diafiltration (SLEDDf/EDDf) have evolved in an attempt to maximise the advantages in using both conventional IHD and CRRT, whilst recognising the disadvantages each technique has when applied to the critically ill patient (Marshall, Golper, Shaver, & Chatoth, 2001). The advantages which CRRT provides in haemodynamic stability, small to middle-sized molecular weight solute removal and control of excess fluid volume can be achieved using hybrid therapies. A longer treatment time in comparison to conventional IHD allow these

therapies to operate at a slower blood and dialysate flow rate to achieve greater haemodynamic stability and electrolyte/metabolic control. The use of high-flux membranes with increased sieving coefficients also enables clearance of a wider range of different molecular-weight sized solutes and to achieve greater fluid balance regulation. Hybrid therapies utilise dialysis machines without the need to purchase dedicated CRRT machinery. The technique is not required to operate continuously allowing the possibility for nocturnal scheduling of sedated critically ill patients and can avoid placing additional demand on existing equipment normally utilised during day time hours for conventional IHD. Although on-line quality control in the production of dialysate is necessary, there is no requirement when using hybrid therapies for the purchase of sterile dialysate solution and replacement fluid which may deliver cost savings when comparisons are made with CRRT. Experience in the use of hybrid therapies describe treatment schedules of six to 12hr associated with a blood flow of 100 to 200ml per min, a dialysate flow rate of 100 to 300ml per min and a replacement rate of 20 to 100ml per min (Baldwin, Naka, Koch, Fealy, & Bellomo, 2007; Kumar, Craig, Depner, & Yeun, 2000; Marshall et al., 2004).

Since the introduction of hybrid therapies a number of small studies have sought to compare the use of hybrid therapies with conventional IHD and CRRT for the treatment of ARF in the critically ill patient. In a RCT similar haemodynamic stability and control of urea and creatine serum concentrations was observed in patients treated with EDD compared with those patients who received CVVH (Kielstein et al., 2004). Anticoagulation requirements for EDD when compared with CRRT were shown to be significantly lower in a prospective non-randomised study and performance unaffected by the incidence of clotting even when no anticoagulation was used (Kumar, Yeun, Depner, & Don, 2004). Marshall and associates (2004) undertook a small prospective observational study using SLEDDf. The authors demonstrated a greater dialysis dose was able to be delivered when compared with conventional or daily IHD treatment schedules and showed SLEDDf could be delivered safely by critical care nurses independent of the services of a dialysis nurse. Although in this study clearance of the larger β_{12} molecule was less than the removal of the smaller urea molecule, the authors suggest convective clearance during SLEDDf could be increased if adjustments are made to the permeability of the membrane. In a randomised controlled comparison of EDDf with CVVH the concentration levels of urea or creatinine and in the correction of electrolyte abnormalities was not shown to be significantly different in patients who

were of similar age and severity of illness (Baldwin, et al., 2007). Whilst Kielstein and associates (2004) reported the correction of acidosis was accomplished more rapidly with EDD, Baldwin and colleagues (2007) observed acidosis was better controlled during CVVH. This occurred despite the use of lactate as a buffer in the replacement solution compared to the use of bicarbonate in the dialysate solution and replacement fluid for EDDf. When the operational expenditure associated with the use of hybrid therapies was compared with the costs associated with CRRT significant savings were made using SLEDD (Berbece & Richardson, 2006).

The view that CRRT is superior to conventional IHD despite a number of operational advantages associated with the technique has not translated into a significant improvement in long-term patient survival or in the return of adequate renal function (Antoun & Palevsky, 2009). A reasonable approach as to the choice of RRT which can best support the critically ill patient with ARF is to regard conventional IHD and CRRT as techniques which are interchangeable. The degree to which this occurs depends upon the severity of the underlying condition of the patient influenced by the resources and clinical expertise available. To date the question of whether hybrid therapies can provide a better outcome in the treatment of ARF for the critically ill patient than conventional IHD or CRRT has not been answered in any prospective comparative controlled study (van Biesen, Veys, & Vanholder, 2007). The major advantages and disadvantages of conventional IHD, CRRT and hybrid therapies are summarised in Table 6. The proponents of CRRT in Europe and Australia believe the disadvantages of the technique are offset by the advantages the treatment can bring to patients who are more at risk of death by offering greater haemodynamic stability, improved biochemical control, and superior fluid balance regulation. Any advantage gained using CRRT over conventional IHD and hybrid therapies nevertheless requires the maximum benefit of the treatment to be achieved by sustaining a continuous approach in the delivery of renal support. The continuity of treatment delivered to the patient will depend on the methods used in the application of the technique and on interventions which can promote the longevity of the extracorporeal circuit.

Application of Continuous Renal Replacement Therapy

The approach adopted in Australia for the management of the critically ill patient operates within a 'closed' ICU model of care similar to the method used in New Zealand (Judson & Fisher, 2006). The primary responsibility for making treatment decisions and writing prescription orders lies with a qualified specialist trained in

intensive care medicine. As a consequence of this approach the management of severe ARF in Australia has moved away from accessing nephrology services for the administration of RRT, to choosing instead the continuous techniques which are able to be delivered solely by the critical nurse under the supervision of the treating intensive care specialist. The major areas for consideration in the application of CRRT include the choice of treatment mode, dialysate and replacement fluid composition, adequacy of treatment dose and factors which affect circuit life.

Choice of Treatment Mode

The only nationwide survey undertaken in Australia which has sought to investigate ICU workforce practices in the management of renal insufficiency found the intensive care specialist was in charge of RRT in 96.7% of cases, and in 98% of patients severe ARF was managed using CRRT operated by the critical care nurse (75 out of 81 ICUs completed the survey) (Silvester, et al., 2001). The authors reported patient outcome was unaffected when in 57.8% of cases no nephrological consult was sought compared with the outcome of patients who were seen by the nephrology team. Analysis of the CRRT mode selected by those units surveyed showed 23.5% used convective therapy in the form of CVVH as opposed to 76.4% who preferred the combined convective and diffusive therapy of CVVHDF. Other aspects regarding the management practices of CRRT investigated by the authors included the use of agents to anticoagulate the extracorporeal circuit. The approach most often used to sustain circuit life was achieved by systemic anticoagulation of the patient using unfractionated heparin (36.8%), or a combination of either regional heparinisation or low-dose heparin given pre-filter (33.4%). A management practice not scrutinised during the survey was in regards to the 'dose' of CRRT prescribed by the intensive care specialist.

Another opportunity to prospectively survey the management practices regarding the delivery of RRT arose again when preparations were made to conduct a large-scale study to determine the optimal dose for CRRT in the management of ARF. Investigators of the randomised evaluation of normal versus augmented level (RENAL) study (2008) recruited 34 ICUs in Australia and New Zealand. All the ICUs who agreed to participate in the study used CRRT as the first choice of therapy for patients with severe ARF, and CVVHDF was once more found to be the most popular therapy selected. The technique of CVVHDF was used in 21 of the 34 ICUs surveyed (62%) followed by 12 (35%) who relied on CVVH and one (3%) choosing instead the option of CVVHD. Out of 34 units surveyed the treatment mode selected was applied in 23 of

cases until either the patient no longer required RRT, or was discharged from ICU, or the patient had died. Of the remaining 11 who responded to the survey, treatment was switched to IHD or SLEDD when patients were close to transfer out of the unit. In addition to these findings the main focus of the survey reported the approach to CRRT prescription was on a fixed-dose regimen and not according to patient weight. The average effluent generated was 2280ml per hour using pre-dilutional CVVHDF, with a dialysate to replacement fluid ratio of 1:1 operating at a blood flow speed of 200ml per minute.

Dialysate and Replacement Fluid Composition

The different attributes of diffusion-based versus convection-based techniques are influenced by the composition of the dialysate and replacement fluid used during CRRT to achieve electrolyte and acid-base homeostasis (Aucella, Paolo, & Gesualdo, 2007). Over the duration of treatment solutes are diffused or ultrafiltered across the semi-permeable membrane using solutions which facilitate the restoration of plasma to near normal values. According to the technique selected the choice of solutions to deliver CRRT can play an important role in how quickly biochemical abnormalities are resolved.

The delivery of solutions containing buffer is essential during CRRT to achieve acid-base balance in the critically ill patient (Aucella, et al., 2007). A constant supply of alkali is required to counter the endogenous production of acid, but is also necessary to compensate for the bicarbonate lost through the haemodialyser or haemofilter. The buffer balance during CVVH occurs by convective transport depending on the losses which are incurred with ultrafiltration and the amount returned in the replacement fluid. Alternatively, the concentration gradient between blood and dialysate provide a feedback mechanism during CVVHD which maintains the buffer balance by diffusive transport (Aucella, et al., 2007). The metabolic conversion of acetate, lactate, or citrate into bicarbonate have all been used as buffers in the formulation of dialysate solutions and in replacement fluids, as well as the direct administration of bicarbonate-based solutions (Aucella, et al., 2007).

The earlier use of acetate as a buffer is now no longer recommended with evidence of reduced acid-base balance control and the reported higher incidence of cardiovascular instability when compared with lactate-based solutions (Heering et al., 1999). The use of lactate-based solutions is usually well tolerated in the critically ill

patient when rapidly metabolised by the liver into bicarbonate. A normal functioning liver can metabolise lactate up to a rate of 100 mmols per hour and supply sufficient bicarbonate to match the hourly fluid exchanges required during CRRT (Macias & Clark, 1996). Commercially available solutions have lactate concentration levels of between 35mmol per L and 45mmol per L which are sufficient for the correction of a metabolic acidosis and in the maintenance of acid-base balance. The incidence of hyperlactataemia using solutions containing even low levels of lactate have nevertheless been reported when exogenous conversion of lactate into bicarbonate is reduced in patients who have liver dysfunction whilst simultaneously exposed to increased production of lactate due to poor circulation (Ho, 2006). The metabolic conversion of citrate into bicarbonate offers an alternative to lactate-based solutions as a buffering agent. A solution containing citrate is used to achieve regional anticoagulation of the circuit in patients at high-risk of bleeding (Davenport & Tolwani, 2009). Simpler protocols in the delivery of citrate along with increased availability of commercially suitable solutions can reduce the potential for acid-base disturbances when there is inadequate or excess citrate metabolism.

In situations where attempts at the supplementation of bicarbonate by metabolic conversion have proved problematic, bicarbonate-based solutions can be directly administered to the patient. An improvement in acid-base control and reduced incidence of cardiovascular instability was observed using bicarbonate-buffered replacement fluid during CVVH when compared with the use of lactate-based replacement fluid (Barenbrock, Hausberg, Matzkies, de la Motte, & Schaefer, 2000). The use of bicarbonate was initially complicated by exposing the patient to the possibility of errors during administration when solutions were manually prepared, and the difficulty experienced in the manufacture and storage of commercially produced bags due to the problem of precipitation in solutions containing magnesium and calcium (Naka & Bellomo, 2004).. A breakable valve between a double chamber bag has resolved the problem of chemical instability by allowing the storage of bicarbonate-based solutions to be mixed only when immediately required at the bedside. The innovation has coincided with the cost of solutions increasing to almost triple the expense of standard single chamber bags and is a disadvantage in the routine use of commercially produced solutions containing bicarbonate.

Apart from influencing acid-base balance the composition of replacement fluid and dialysate will assist with the regulation of electrolytes and other important

substances. Severe electrolyte derangements can occur during CRRT in the absence of careful monitoring and without attention given to the prescription of solutions. The risk of contamination in the preparation of customised solutions (Kanagasundaram, Larive, & Paganini, 2003), or errors in the prescription and injection of additives (Johnston, Boiteau, Charlebois, Long, & David, 2004) make the use of commercially available fluids the safest option. Although some additives may need to be injected at the bedside the composition of fluid is ready for use and comprises of electrolytes and glucose at physiologic concentration levels which can be administered safely. A typical bag manufactured for CRRT will contain sodium 140mmol per L, chloride 108 to 112mmol per L, potassium 0 to 4mmol per L, calcium 1.5 to 1.75mmol per L and glucose 0.15mg per L (Aucella, et al., 2007). The control of serum potassium levels is a major concern during CRRT and, without the addition of potassium in the dialysate solution and replacement fluid, the patient can become hypokalaemic. Sustained episodes of low serum potassium levels places the patient at risk of developing arrhythmias and the possibility of cardiac arrest (Ahern-Gould & Stark, 1998). Although hyperkalaemia can be a feature of AKI due to the effects of rhabdomyolysis (Bosch, Poch, & Grau, 2009), the regular supplementation of potassium to prevent hypokalemia is usually necessary. The addition of potassium in potassium-free solutions requires careful monitoring to ensure the desired serum potassium level is maintained. Algorithms designed to assist with potassium supplementation during CRRT can make the control of serum potassium levels easier to regulate (Brooks, 2006). The alternative electrolyte, sodium also requires monitoring with the control of serum levels influenced by the mode of treatment selected. The movement of sodium can be controlled using convective and diffusive transport mechanisms without concern regarding the rapid clearance of the ion, provided concentration levels of sodium are sufficient in the dialysate solution and replacement fluid. The ability to achieve normal serum sodium levels was nevertheless demonstrated to be superior using CVVHdf after the treatment mode was retrospectively compared with the alternative treatment mode of CVVH (Morimatsu, Uchino, Bellomo, & Ronco, 2003). The inclusion of dialysate solutions containing sodium at sufficient concentrations to offset movement by diffusion was reported by the authors more likely to avoid hyponatremia when, despite adequate concentration of sodium in the replacement fluid, comparisons were made with the movement of sodium by convection. Disturbances in the balance of other electrolytes can also occur during CRRT. The exchange of large volumes of fluid containing calcium place the patient at risk of hypercalcemia with the same cautions required to maintain an appropriate serum

magnesium level (Aucella, et al., 2007). The prolonged use of CRRT may induce hypophosphatemia requiring correction by intravenous bolus administration, but the ion has been added successfully to solutions containing calcium without causing precipitation (Trojanov, Geadah, Ghannoum, Cardinal, & Leblanc, 2004).

The large volume of fluid which is exchanged during CRRT requires careful attention to the maintenance of fluid sterility and in the correct adjustment of fluid prescriptions when solutions are administered by the critical care nurse. Stabilisation of acid-base balance and correction of electrolyte disturbances is not only dependent on differences in the technique selected, but is also influenced by the composition of fluids delivered with each treatment. The physical properties of fluids chosen are now increasingly being recognised as important to the overall determination of outcomes when CRRT is required in the management of the critically ill patient (Schetz, Leblanc, & Murray, 2002),

Adequacy of Treatment Dose

The term 'urea kinetic modelling' (UKM) is used to describe a technique commonly applied in clinical practice to quantify the dialysis dose required for patients with ESRD (Kemp, Parnham, & Tomson, 2001). The dose of dialysis therapy is expressed in terms of urea clearance through the dialysis membrane (K), duration of dialysis (t), over the volume of urea distributed in the patient. The Kt/V formula is an established measurement of adequacy based on the clearance of urea to achieve a recommended dose which is associated with improved survival of patients who have ESRD (Ricci & Ronco, 2005). A Kt/V of at least 1.2_{UREA} is considered in the management of ESRD an adequate treatment dose.

In determining an adequate treatment dose for the management of ARF a number of problems are encountered when the Kt/V formula is applied to the critically ill patient. The unsteady state of the patient may create uncertainty about urea levels due to high catabolism and fluctuations in blood volume complicating the estimation of solute clearance. The ability to deliver the prescribed dose can be affected by inadequate blood flow using temporary vascular access devices, frequency of clotting in the extracorporeal circuit, and technical problems in the operation of machinery (Ricci & Ronco, 2005). As a consequence of the difficulties experienced using the Kt/V approach the measurement of clearance according to the ultrafiltration rate (ml per kg per hr) has now been adopted for CRRT (Ronco, et al., 2000). In applying the Kt/V formula

normally associated with IHD a treatment dose of 35ml per kg per hr in a 70kg patient using pure haemofiltration would achieve a Kt/V of 1.4_{UREA}. This is a calculation based on the assumption treatment was able to be sustained for 24hr and a recognition of uncertainty regarding the fluctuations in the distribution of urea in the critically ill patient. The application of CRRT can make it difficult to achieve the predicted intensity of dose in ml per kg per hr or equivalent Kt/V due to problems associated with its capacity to operate continuously. A problem in the calculation of treatment dose can also arise when the ultrafiltration rate is combined with the addition of dialysis such as in CVVHdf and how to determine clearance in the effluent produced using both approaches.

An international survey investigating the practices of nephrologists and intensive care specialists in the management of critically ill patients found 67% of those who responded to the survey did not measure the dose of RRT delivered, and in 60% of cases intensive care specialists as opposed to 40% nephrologists provided no prescription on the dose required in the management of ARF (Ricci, Ronco, D'amico, et al., 2006). A reduction in the ability to reach the desired treatment dose was reported to be associated with patients who were overweight when using IHD (Evanson et al., 1998). The authors observed patient weight was a contributing factor which resulted in 70% of dialysis delivered being under a Kt/V of 1.2_{UREA}. In a recent US survey investigating dose intensity of renal support for the critically ill patient, only 17.9% of those surveyed reported dosing CRRT according to patient body weight when the practices of institutions were reviewed (Overberger, et al., 2007). The same lack of scrutiny towards a relationship between treatment dose and body weight was also reported by the RENAL study investigators after a survey was conducted on predominately CRRT practice in Australia and New Zealand ICUs (RENAL Replacement Therapy Study Investigators, 2008). None of the participating study sites prior to commencement of the investigation surveyed had previously adjusted RRT according to patient weight. The survey revealed a preference in 62% of ICUs for a fixed-dose RRT regimen of 2L per hour in the volume of effluent generated.

The importance of determining an adequate dialysis and ultrafiltration dose has seen an upsurge of interest following reports of improved patient outcomes when the intensity of RRT delivered is increased. In a single centre randomised study the application of CRRT using pure haemofiltration was carried out in 425 critically ill patients (Ronco, et al., 2000). The authors reported patients who were prescribed an

ultrafiltration rate of 35ml per kg per hr or 45ml per kg per hr had significantly better outcomes at 15 days from the last day of treatment when compared with patients who were prescribed a lower ultrafiltration rate of 20mL per kg per hr (35ml per kg per hr group P-value = 0.0007, 45ml per kg per hr group P-value = 0.0013). A shortcoming of this study possibly lies in the design which did not control for differences in other supportive management practices, with the trial taking five years to complete and changes in how patients were managed being a confounding factor that may have influenced survival in some patients. The benefit of increasing the intensity of renal support has also been observed in critically ill patients receiving IHD. During a randomised study undertaken by Schiffl and colleagues (2002) patients were assigned to either the scheduling of daily IHD or conventional IHD delivered on alternate days. The authors observed a significant difference in the survival of patients who were exposed to the daily scheduling of IHD when the dose prescribed for both treatment groups targeted a Kt/V of 1.2_{UREA} . Out of the 146 patients who completed the study in the 74 patients who were treated with daily IHD, death at 14 days after last treatment dose had occurred in 19 patients (26%) compared with 31 patients (43%) included in the 72 patients who had instead received conventional IHD (P-value = 0.04). The results are possibly difficult to generalise to the wider critically ill population since the study excluded patients who were haemodynamically unstable and is perhaps reflected by the lower mortality rate observed during the trial (34%) compared with those reported in other studies.

An increase in the intensity of renal support has not always produced similar results of a positive effect on patient outcomes. The delivery of higher ultrafiltrate volumes was not shown by Bouman and associates (2002) to improve survival when measurement of patient recovery following discontinuation of treatment was extended from short-term analysis which had occurred with the other studies previously discussed. As part of investigations into early versus late initiation of RRT the authors also observed the effects of high volume haemofiltration (3 to 4L/hr) versus low volume haemofiltration (1 to 1.5L/hr) in 106 critically ill patients, and reported no difference in survival when patient follow-up was extended out to 28-days (high volume haemofiltration 74.3% versus low volume haemofiltration 68.8%, P-value = 0.80). A confounding factor which may have influenced the outcome observed by Bouman and associates (2002) between the different treatment groups arose as a result of not standardising treatment dose according to patient weight. This had the potential to

increase the variability of RRT delivered when the allocated prescribed dose was given regardless of extremes in body weight.

The contradictory evidence observed regarding the intensity of renal support on improving the outcomes of critically ill patients demonstrate the shortcomings of making decisions to change practice based on the findings of single-centre studies. The uncertainty over dose intensity in the delivery of RRT has been the subject of two multi-centre randomised, controlled trials recently undertaken in the US and as a collaborative project between Australia and New Zealand. The sample size and design of both the ATN and RENAL studies are examples of attempts made by investigators to provide adequate statistical power and robustness when making recommendations on the optimal dose of RRT required for improving survival in the management of patients with severe ARF.

The members of the ATN study investigation team have recently published the results of the US trial which did not demonstrate a significant difference in patient mortality or an improvement in the recovery of kidney function when the intensity of renal support was increased (Acute Renal Failure Trial Network, 2008). Using a prospective, randomised, parallel-group study design 1124 patients were assigned to receive either a treatment strategy of IHD six times per week or CVVHDF at 35ml per kg per hr, compared with the other category of patients who received instead a treatment strategy of IHD three times per week or CVVHDF at 20ml per kg per hr. In the event of haemodynamic instability the study allowed patients assigned to IHD to switch over and receive the same dose-intensity using CVVHDF or SLEDD. Out of the 563 patients who received the intensive treatment strategy 302 patients (53.6%) died within 60 days following randomisation as opposed to 289 (51.5%) out of 561 patients who had undergone the less intensive treatment strategy (P-value = 0.47). Also, no significant difference was observed in the recovery of kidney function with complete return by day 28 occurring in 85 patients (15.4%) and partially present in 49 patients (8.9%) out of the 553 survivors who had previously received increased renal support. This contrasted with the other 555 patients at day 28 who had been treated using decreased renal support with complete return of kidney function reported in 102 patients (18.4%) and partial recovery observed in 50 patients (9.0%) (P-value = 0.24). A similar result occurred when patients were followed-up at 60 days with no significant difference in the requirement for on-going dialysis reported when patients were discharged out of hospital (15.7% of intensive treatment strategy patients versus 16.4% of less intensive

treatment strategy patients, P-value = 0.75). The findings of the ATN study suggest there was no benefit of improved patient survival or recovery of kidney function when the intensity of treatment was increased above a Kt/V dialysis dose of 1.2_{UREA} or an ultrafiltration rate greater than 20ml per kg per hr.

The ATN study was a rigorous attempt to control the supportive management of patients throughout the duration of the study, allow for generalisation of the findings to the typical critically ill patient, enforce standardisation of dialysis/ultrafiltration dosages according to randomised allocation, and achieve the statistical power required to detect a 10% difference in long-term survival (60 days) between the two treatment groups. The approach taken was not entirely successful in achieving an equal comparison between 'low' and 'high' dose RRT for a reliable relationship between dose and response to be established. The switching between IHD and CVVHdf/SLEDD may have led to a crossover effect and inadvertently delivered an equivalent dose of low-intensity CVVHdf/SLEDD when the swap occurred despite the patient being assigned to receive high-intensity IHD.

The investigators of the RENAL study have also recently published observations on the other multi-centre randomised, controlled trial established to address the issue of dose intensity of RRT as a factor influencing patient outcomes. In the RENAL study comparisons of intensity were made using only post-dilution CVVHdf with the 'standard' dose of 25ml per kg per hr versus the augmented dose of 40ml per kg per hr (RENAL Replacement Therapy Study Investigators, 2009). A difference in the RENAL study when compared with the approach taken by the ATN study group was the investigation of renal support resembled clinical practice in Australian and New Zealand ICUs. The RENAL study was designed for the randomisation of 1,500 patients with a statistical power to detect an 8.5% reduction in patient survival at 90 days. On completion of the study the authors reported 1,508 patients with similar baseline characteristics had been randomly assigned to receive either the augmented (747), or the standard (761) treatment dose. After 90 days following hospital admission 322 deaths (43.1%) occurred in the group of patients who had received renal support of a higher-intensity compared with 332 deaths (43.6%) observed when patients were instead allocated renal support of a lower-intensity (odds ratio, 1.00; 95% CI, 0.81 to 1.23; P-value = 0.99). Survivors of the lower-intensity group who continued to require RRT at 90 days (18 out of 411) was not significantly different to patients in the higher-intensity group (27 out of 399, P-value = 0.14).

The findings of the ATN and RENAL studies suggest renal support beyond an adequate level of intensity provides no additional benefit to the critically ill patient. Survival of the patient and recovery of renal function does not appear to be improved when the Kt/V_{UREA} exceeds 1.2, or is greater than 35ml per kg per hr (Acute Renal Failure Trial Network, 2008; RENAL Replacement Therapy Study Investigators, 2009). On reaching the same conclusion as reported by authors of the ATN and RENAL studies, the investigators who established the Dose Response Multi-centre International (DO-RE-MI) collaborative initiative observed the ability to deliver an ‘individualised’ renal dose in patients was more difficult when associated with a higher body weight (DO-RE-MI Study Group, 2009). A dose below 20ml per kg per hr was suggested by authors of the European prospective observational study as being suboptimal in the management of severe ARF and the threshold reached when body weight prescription was constrained by the availability of technology to deliver the required intensity of renal support. The importance of ensuring the prescribed intensity of renal support is delivered to the patient make quality assurance activities towards assessment of actual dose received essential to avoid the risk of under dosing the patient (Palevsky, 2009). In order to achieve the required intensity of renal support consideration needs to be given to how the continuity of CRRT can be maintained in the management of the critically ill patient with severe ARF.

Factors Which Affect Circuit Life

The ability to deliver the correct intensity of renal support using CRRT is influenced by the longevity in the functionality of the extracorporeal circuit. A physiological factor which can cause premature clotting of the circuit occurs following exposure of blood to non-biological materials. The use of anticoagulants can modify the response of the coagulation pathway and delay the development of blood clots, whilst the location of replacement fluid can dilute the concentration of procoagulatory substances (Joannidis & Oudemans-Van Straaten, 2007). Other factors of a mechanical nature can also impact on circuit life and cause unexpected circuit failure to occur (Kim, Fealy, Baldwin, & Bellomo, 2010). An understanding of the theoretical principles behind the technique and operational training in the use of equipment and the monitoring of circuit pressures is important. Consideration should be given to the design features of the extracorporeal circuit which incorporates the roller-pump, the haemofilter and venous bubble or air- trap. The influences of the venous access catheter

and the vascular insertion site on blood flow are other mechanical factors regarded as important in determining the longevity of the circuit.

Blood Coagulation and Extracorporeal Circulation

The sequence of events which cause the coagulation of blood is traditionally described as initially involving the intrinsic and extrinsic coagulation pathways. Activation of the intrinsic (contact) pathway is caused by blood vessel injury as opposed to the stimulation of the extrinsic (tissue factor) pathway due to exposure of substances at the site of vessel wall damage (Moran & Viele, 2005). Both of the initiating pathways activate coagulation factors in a sequence of events which join together to form a common coagulation pathway. The intrinsic pathway is initiated when coagulation Factor XII is activated by elements within the lumen of blood vessels. Mobilisation of coagulation Factor XII initiates activation of coagulation Factors XI and IX. In the presence of activated Factor IX, coagulation Factor VIII, calcium and phospholipids activate coagulation Factor X. Platelets play an important role at this point by releasing calcium and phospholipids. Initiation of the extrinsic pathway occurs when tissue factor, not normally circulating in blood plasma, is released as a result of endothelial damage to the blood vessel wall. Released tissue factor combines with coagulation Factor VII and activates both coagulation Factors IX and X. Once initiating pathways activate Factor X a common coagulation pathway is established and coagulation Factor V converts prothrombin into thrombin. Fibrinogen is converted by thrombin into fibrin and creates a network of threads which forms a blood clot when stabilised by the aggregation and adhesion of platelets (Moran & Viele, 2005).

The circulation of blood through an extracorporeal circuit will eventually cause blood to clot and is a normal physiological response once blood is circulated outside of the body (Davenport, 1997). The mobilisation of the intrinsic coagulation pathway is thought to be activated when on commencement of treatment there is a rapid adsorption of plasma proteins onto the membrane surface area within the haemofilter and along the entire extracorporeal circuit. As a result of fibrinogen adsorption and exposure to thrombin the mechanism of interaction which occurs when blood comes into contact with non-biological materials is accompanied by the activation of platelets and the development of blood clots. In a prospective study on platelet function a reduction in platelet aggregation was observed during CVVH associated with activation of platelets caused by adherence to the filter membrane and blood lines (Boldt, Menges, Wollbruck, Sonnerborn, & Hempelmann, 1994). A decrease of 62% in platelet aggregation was

recorded after samples of arterial blood were exposed to adenosine diphosphate and compared with a group of patients who served as the control not undergoing CVVH. The dysfunction of platelets was reported by the authors to be most pronounced when the duration of CVVH occurred over several days and the extended duration of treatment coincided with an increase in patient mortality.

The development of blood clots in the extracorporeal circuit has also been associated with the extrinsic coagulation pathway. The release of tissue factor along with other substances, normally only discharged into the circulation when damage has occurred to the blood vessel, can also be present in the bloodstream when cytokine and endotoxin levels are elevated. A study undertaken by Cardigan and associates (1999) found in the six out of 12 critically ill patients recruited there was an increase during CVVH in monocyte tissue factor levels above baseline measurements. The change in tissue factor levels was significantly correlated to a change in thrombin-antithrombin complexes over the lifespan of the circuit ($r = 0.49$, $P\text{-value} = 0.02$) and inversely correlated with circuit longevity ($r = -0.72$, $P\text{-value} = 0.03$).

A number of factors predispose the CRRT circuit to the early development of blood clots (Schetz, 2001). The concentration of coagulation markers was observed by Stefanidis and associates (1996) to be elevated in critically ill patients with ARF prior to commencement of CVVH. The authors found in 14 patients whose causes of ARF varied there was significant elevation above normal in the coagulation marker levels of fibrinopeptide A (33 nanograms (ng) per ml $SD\pm 20$, normal range <3.0) and thrombin-antithrombin III complex (11ng/ml $SD\pm 5$, normal range 1.0-4.0). Stimulus for coagulation may occur secondary to the disease process as in the case of sepsis where levels of naturally occurring anticoagulants are reported to be lower in some critically ill patients with severe infection (Hesselvik, Malm, Dahlback, & Blomback, 1991). Premature clotting in polyacrylonitrile haemofilters was observed to occur more frequently during CVVH when levels of antithrombin III and heparin co-factor II were reduced (Salmon et al., 1997). Out of the 12 critically ill patients recruited to participate in the study nine had baseline measurements which were below the normal reference range. On commencement of treatment the lowest level of antithrombin III and heparin co-factor II observed in four patients was reported by the authors to be associated with reduced circuit life. Based on the studies reviewed the critically ill patient is vulnerable to early activation of the coagulation pathway making the challenge of sustaining the

extracorporeal circuit more difficult to achieve in efforts to maximise the delivery of CRRT.

Anticoagulation Strategies

To sustain the extracorporeal CRRT circuit and delay the onset of blood clotting anticoagulant drugs are usually necessary. The goal of anticoagulation in CRRT is to maximise the anticoagulant affect inside the haemofilter and along the circuit, whilst minimising the potential harmful effects of systemic anticoagulation (Bellomo & Ronco, 2002a). Selection of the anticoagulant agent is determined by the patient's underlying illness, availability of the anticoagulant and clinical experience (Mehta, 1996). Numerous anticoagulants and modes of administration have been advocated (Oudemans-van Straaten, Wester, de Pont, & Schetz, 2006). The most common available anticoagulants and strategies used for CRRT in Australia include unfractionated heparin, regional heparinisation, low-molecular heparins and heparinoids, regional citrate, platelet-inhibiting agents and thrombin antagonists. The following sections will focus on each anticoagulant with a brief description of the method, the efficacy of outcomes from published reports and issues related to its use, side-effects and contraindications. The efficacy of CRRT without anticoagulation in patients at high-risk of bleeding will also be discussed.

Unfractionated Heparin.

Unfractionated or standard heparin is the anticoagulant agent most commonly used in CRRT to prolong the life of the extracorporeal circuit in Australia (Silvester, et al., 2001) and in other countries such as the United Kingdom (Wright, et al., 2003). It is widely available and relatively inexpensive. Clinicians are also familiar with its mode of action, dosing and monitoring considerations (Shulman, Singer, & Rock, 2002). Standard heparin is made up of long-chain glycosaminoglycans which have a diverse molecular weight ranging between 5,000 and 30,000Da (Shulman, et al., 2002), and in one study were not shown to cross the membrane during haemofiltration and enter the ultrafiltrate in sufficient quantities to be measured (Singer et al., 1994). The anticoagulant effect of heparin is primarily exerted on antithrombin III to block the action of thrombin and factor Xa (Abramson & Niles, 1999). The pharmacokinetics of heparin, whilst time and dose-dependent, can be unpredictable and considerable variability in affect can occur from patient to patient (Schetz, 2001). Anti-factor Xa assays specifically relate to levels of factor Xa and the affect this has on coagulation

(Webb, Mythen, Jacobson, & Mackie, 1995). The anticoagulant effect of heparin is monitored in CRRT by measuring the activated partial thromboplastin time (aPTT) (Schetz, 2001). The normal aPTT varies between different laboratories and can range from 25 to 38 seconds (Hillman & Ault, 2002).

Circuit priming with heparin added to 0.9% saline is used in many centres (Davenport, 2004a). It is theorised the negatively charged heparin molecule adheres to the plastic of the circuit tubing. The priming solution has been reported to vary from 5,000 to 20,000 International Units (IU) of heparin added into 1 to 2L of 0.9% saline (Abramson & Niles, 1999). In one randomised cross-over study no reduction was observed in the thrombogenicity of the extracorporeal circuit when primed with a solution of 0.9% saline containing heparin at a concentration of 2,000IU per L or 10,000IU per L compared to circuits which had no heparin added to the saline solution (Opatrny et al., 2002). A systemic loading dose of 5,000IU is administered by some centres before the initiation of CRRT to optimise the anticoagulatory effect of heparin when blood is first exposed to the extracorporeal circuit (Schetz, 2001). This is followed by a continuous infusion of heparin delivered either through the circuit or directly into the body. The presence or absence of coagulation abnormalities in the critically ill patient will influence what dose is delivered. Bellomo and Ronco (2002a) suggest a dose of 8 to 10IU per kg per hr, administered into the blood line before the haemofilter, will result in a slight systemic prolongation of the aPTT suitable for patients who are considered at low-risk of bleeding (42 to 46 seconds [s]). In one randomised cross-over study differences in the concentration of heparin and in the delivery site before the haemofilter was not shown to affect circuit life (Leslie, Jacobs, & Clarke, 1996).

Van de Wetering and associates (1996) investigated the relationship of heparin on haemofilter survival. Survival of the haemofilter was reported to be proportional to the aPTT and not to the heparin dose. Clotting of the haemofilter occurred less frequently when the aPTT was increased by 10s, but coincided with a 50% increase in the incidence of intracranial or retroperitoneal haemorrhage which required a blood transfusion or resulted in the death of the patient. Whilst not necessarily a predictor that bleeding will not occur, systemic aPTT measurements do provide a method of monitoring the risks associated with heparin administration. A patient arterial blood aPTT measurement of between 35 and 45s is practiced in many centres to prevent circuit clotting and minimise the risk of systemic haemorrhage (Abramson & Niles, 1999). Whilst coagulation indices such as aPTT are useful in determining the safety of a

given heparin regimen, the benefit of coagulation tests in monitoring the effect of heparin on circuit clotting has not been proven (Baldwin, Tan, Bridge, & Bellomo, 2000; Holt, Bierer, Glover, Plummer, & Bersten, 2002).

Haemorrhage in up to 47% of patients has been reported when unfractionated heparin is used to anticoagulate the blood during CRRT even when minimal amounts are employed (A. A. Kaplan, Longnecker, & Folkert, 1984; van de Wetering, et al., 1996; Ward & Mehta, 1993). However, in a retrospective study by P. Y. Martin and associates (1994) not all bleeding episodes reported were found to be solely attributed to heparin administration but caused by the patient's underlying condition.

Heparin-induced thrombocytopenia (HIT) type II is a complication which can also be potentially life-threatening. The syndrome occurs when exposure to heparin causes an immune response and the development of antibodies against the multi-molecular complex of heparin and platelet factor 4 (PF4) (Chong, 2003). The HIT antibody causes excessive platelet activation and agglutination resulting in the formation of thrombi. The depletion of platelets also occurs simultaneously due to the clearance of activated and antibody-coated platelets by the reticulo-endothelial system. The incidence of HIT type II antibodies is reported to be higher in critically ill patients whose exposure to heparin is greater during CRRT than the exposure experienced by patients receiving long-term intermittent haemodialysis (Davenport, 2004b).

Heparin is considered a safe anticoagulant for use during CRRT provided administration is protocol driven to ensure the anticoagulant effects of the agent are monitored to achieve a low level of systemic anticoagulation in patients who are not regarded as being at risk of major bleeding (Oudemans-van Straaten, et al., 2006). Should haemorrhage occur in patients treated with CRRT, the half-life of heparin is relatively short and if necessary, the effects can be quickly reversed easily by the administration of protamine (Davenport, 2004a). A decrease in circuit life due to premature clotting or evidence of excessive bleeding may be an early sign of HIT with the manifestation of platelet antibodies adversely affecting the critically ill patient (Bellomo & Ronco, 2002a). In the event of a positive antibodies result, heparin administration should cease and an alternative agent or strategy selected.

Regional Heparinisation.

A 'regional' heparin effect localised to the CRRT circuit can be achieved when protamine is administered on the return line of the extracorporeal circuit. Unfractionated heparin delivered pre-filter maximises the anticoagulant effect inside the haemofilter and along the circuit. Protamine is then administered to reverse the anticoagulant effects of heparin before the blood is returned to the patient (Mehta, Dobos, & Ward, 1992). To avoid anticoagulation of the patient's systemic circulation monitoring of the circuit and the patient's aPTT is essential. The approach requires a circuit aPTT which is prolonged and a patient aPTT which is normal (Bellomo & Ronco, 2002a).

The use of protamine to neutralise the effect of heparin has been shown to be a safe procedure provided adequate monitoring is undertaken (A. A. Kaplan & Pettilo, 1987; Morabito, et al., 2003). In a prospective cross-over study regional heparin-protamine anticoagulation was shown to extend circuit life in comparison to the use of low-dose heparin but variations in circuit life were not shown to be statistically significant. Whilst no complications in the administration of protamine were observed, the study was not designed to detect differences in the incidence of bleeding (Bellomo, Teede, & Boyce, 1993).

Regional heparinisation may be useful in patients at high-risk of bleeding in situations where early clotting over the duration of a few hours produces unsatisfactory circuit life when no anticoagulant is used (Morabito, et al., 2003). A rebound effect can occur as a result of protamine activity having a shorter half-life than heparin after the heparin-protamine complex is broken down by the reticuloendothelial system and heparin is released back into the circulation. Blood samples are required to be taken regularly and the delivery of protamine and heparin adjusted accordingly. The administration of protamine can be associated with hypotension, anaphylaxis, cardiac depression, leukopenia and thrombocytopenia (Carr & Silverman, 1999; Horrow, 1985). In view of the adverse consequences of hypotension as a side effect and the difficulty associated with monitoring the interaction between heparin and protamine the use of regional heparinisation is considered clinically difficult to perform.

Low-Molecular-Weight Heparins.

Low-molecular weight heparins (LMWHs) were introduced as a possible replacement for unfractionated heparin in antithrombotic therapy. Compared with unfractionated heparin, LMWH is pharmacokinetically more predictable and

anticoagulant response less unreliable (Schetz, 2001). Platelet function is not affected as much in comparison to unfractionated heparin with the incidence of HIT type II less likely to occur with LMWH (Warkentin et al., 1995). Under the trade names of Dalteparin, Enoxaparin, Nadroparin and Fragmin, LMWHs are glycosaminoglycans which have a reduced chain length (Davenport, 2004a). They are extracted from the depolymerisation of unfractionated heparin and have molecular weight close to 5,000 Da (Abramson & Niles, 1999). Whilst the influence of factor Xa remains unchanged, the reduction in the molecular weight of heparin reduces its effect on antithrombin III activity and the risk of systemic haemorrhage (Mehta, et al., 1992). This explains why when using LMWHs, reversal with protamine is only partial (Schetz, 2001).

To anticoagulate the extracorporeal circuit the dose required in CRRT is different according to the type of LMWH used. The half-life of different LMWHs also vary but all have a half-life which is approximately twice that of standard heparin (Davenport, 2004a). Since raised antithrombin activity is not affected by the inhibition of factor Xa, the measurement of aPTT values to determine the degree of anticoagulation activity is not as useful a test as it is when standard heparin is used. In order to regulate the degree of factor Xa inhibition, assays to monitor factor Xa activity not normally requested as part of routine coagulation blood tests should be included in the coagulation profile. An anti-factor Xa level of 0.25U per ml adequately anticoagulates the circuit whilst levels of anti-factor Xa between 0.45 and 0.8U per ml have been associated with bleeding complications (Jeffrey, Khan, Douglas, Will, & Davison, 1993).

Low-molecular-weight heparins have been shown to be just as effective but not superior to standard heparin in prolonging circuit life (Shulman, et al., 2002). Biological activity is different and effects not necessarily interchangeable with different types of LMWHs. In a double-blind, randomised, cross-over study, Nadroparin and Dalteparin were shown to be bioequivalent with respect to anti-factor Xa activity. No difference was recorded in circuit longevity during CVVH with no relationship shown between anti-Xa activity and circuit survival time (de Pont, Oudemans-vanStraaten, Roozendaal, & Zandstra, 2000). No difference in circuit life and bleeding complications were reported when fixed-dose Dalteparin was compared with adjusted dose unfractionated heparin. However, anticoagulation of the circuit with Dalteparin proved to be more expensive than circuit anticoagulation with standard heparin (Reeves, Cumming, Gallagher, O'Brien, & Santamaria, 1999). In a small randomised control study the use of

Enoxaparin extended circuit life and correlated with anti-factor Xa activity making comparisons in treatment costs comparable with standard heparin which had a shorter circuit life and a higher incidence of bleeding (Joannidis et al., 2004). Unless superior circuit life without major bleeding is able to be achieved to reduce cost associated with LMWHs and the requirement for anti-Xa assays there is no significant advantage to support its use.

Heparinoids.

Low-molecular weight heparinoids such as Danaparoid are a group of synthetic glycosaminoglycurons which have a low-grade sulfation when compared with molecular modified heparin that reduces the incidence of platelet cross-reactivity with heparin-induced antibodies (Vun, Evans, & Chong, 1996). It is recommended a bolus dose of between 750 and 2,500U of Danaparoid is administered at the start of CRRT. This is followed by a maintenance dose of 2 to 4U per kg per hr which is adjusted to achieve an anti-factor Xa level of between 0.4 and 0.6U per ml (Wester, 2004). In a small observational study Danaparoid was successfully used to anticoagulate the CRRT circuit in patients suspected of, or had developed HIT (Lindhoff-Last, Betz, & Bauersachs, 2001). The anticoagulant agent has a comparatively long-half-life which is lengthened even further in renal failure. This can potentially cause problems of over anticoagulation when large infusion doses are used and there is not careful monitoring of both anti-factor Xa and aPTT (Davenport, 1998). There is no simple antidote to Danaparoid should bleeding occur other than supportive measures such as the administration of fresh frozen plasma (Davenport, 2004a).

Regional Citrate.

Citrate prevents coagulation by the chelation in whole blood of ionised calcium (Schetz, 2001). An ionic bond is formed between citrate and calcium which reduces the amount of ionised calcium available for blood to clot normally. The depletion of ionised calcium interrupts activation of the clotting cascade and prevention of platelet aggregation (Davenport & Tolwani, 2009). It is routinely used to prevent coagulation in blood sample specimen tubes and in blood transfusion bags. Experience in the use of trisodium citrate to anticoagulate the CRRT circuit was reported to be limited 10 years ago following a practice survey of Australian ICUs (Silvester, et al., 2001). The development of protocols to address concerns regarding its application and the availability of suitable 'ready-made' replacement fluid and dialysate solution has more

recently seen an upsurge of interest in the use of citrate (Davies, Morgan, & Leslie, 2008; Fealy, Baldwin, Johnstone, Egi, & Bellomo, 2007).

Regional citrate anticoagulation involves the infusion of citrate ions into the extracorporeal circuit. On entry into the circuit ionised calcium within normal blood combines with citrate to form calcium-citrate complexes of non-ionised calcium. As blood travels along the circuit, the level of ionised calcium is reduced as the level of non-ionised calcium is elevated and prevents the coagulation of blood (Abramson & Niles, 1999). Systemic anticoagulation is avoided in three ways by limiting the effects of citrate to the extracorporeal circuit but allowing the restoration of normal serum ionised calcium levels. Firstly, the citrate molecule is small and able to pass through the membrane easily by diffusion or convection before blood is returned to the patient (Morgera et al., 2004). Secondly, the effect of citrate is able to be neutralised by the administration of calcium as a separate infusion to ensure a normal serum ionised calcium level is maintained (Davenport, 1998). Thirdly, citrate present in the return line is diluted by the total blood volume when it re-enters the body and is rapidly metabolised by the liver. Calcium released from the calcium-citrate complexes is no longer non-ionised and therefore contributes to the normalisation of systemic ionised calcium levels (Abramson & Niles, 1999).

A variety of methods are described in the literature which use different approaches in the way regional citrate is administered and how the effects on metabolism are monitored with many of these techniques attempting to simplify the procedure and reduce metabolic derangements (Bagshaw, Laupland, Boiteau, & Godinez-Luna, 2005; Cointault et al., 2004; Hofmann, Maloney, Ward, & Becker, 2002; Kutsogiannis, Gibney, Stollery, & Gao, 2005; Kutsogiannis, Mayers, Chin, & Gibney, 2000; Mehta, Mc Donald, Aguilar, & Ward, 1990; Mitchell et al., 2003; Monchi et al., 2004; Naka et al., 2005; Palsson & Niles, 1999; Tolwani, Campbell, Schenk, Allon, & Warnock, 2001). Tolwani and associates (2006) have reported on a simple technique applied to CVVHDF. As shown in Figure 2.10 this method uses a replacement fluid which contains citrate and a 'calcium-free' bicarbonate-buffered dialysate solution. The replacement fluid containing the citrate is delivered pre-filter with a solution of calcium gluconate attached to the patient through a separate central line. As blood travels along and mixes with citrate in the circuit, blood taken from the post-filter sample port allows the anticoagulant effect to be monitored. An arterial blood sample taken from the patient enables the effect of citrate on serum ionised calcium levels to be monitored when blood

is returned to the patient. According to the results from post-filter and patient arterial blood samples adjustments can be made to the delivery rate of the replacement fluid containing the citrate and in the calcium-free bicarbonate-buffered dialysate solution. The blood pump speed and the delivery rate of calcium gluconate infusion can also be adjusted in order to maintain a normal serum ionised calcium level of 0.9-1.3mmol per L and avoid metabolic alterations in the patient's blood pH.

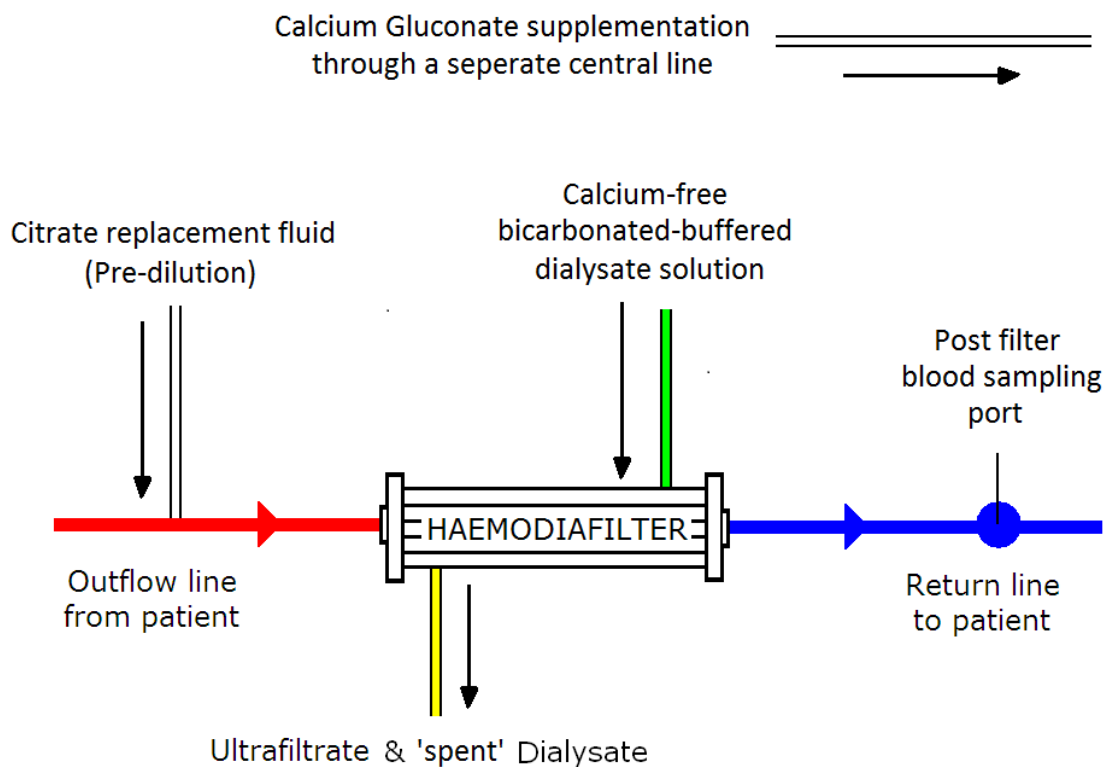

Figure 2.10. Regional citrate anticoagulation for continuous veno-venous haemodiafiltration.

The use of regional citrate to anticoagulate the CRRT circuit has been reported to be associated with a reduced incidence of bleeding and a safer option to heparin in patients at high risk of bleeding or as a suitable alternative in patients with, or a history of, HIT (Mehta, et al., 1990; Palsson & Niles, 1999). Superior circuit life has also been observed by Monchi and associates (2004) in a RCT when regional citrate was used to anticoagulate the circuit and a comparison of circuit life made with circuits anticoagulated with heparin. The authors recorded circuit life of between 44hr and 140hr with a median circuit life of 70hr for circuits' anticoagulated with citrate, compared to circuit life of between 17 hr and 48 hr with a median circuit life of 40hr when heparin was used to anticoagulate the circuit. A comparison of regional citrate versus regional heparinisation found no statistical difference in circuit life when the

effect of these agents was assessed using a randomised controlled crossover design, but the small sample size may have restricted the ability of the study to detect significant variations in circuit life between the two anticoagulation strategies (Fealy, et al., 2007).

A number of metabolic complications can occur when using regional citrate to anticoagulate the CRRT circuit (Kutsogiannis, et al., 2005; Mehta, et al., 1990; Morgera, et al., 2004). Whilst these disturbances required intervention to correct the derangement none were reported to be of a life-threatening nature. The citrate ion is usually administered in the form of a hypertonic trisodium citrate solution. This compound as well as delivering citrate may also elevate serum sodium levels when in a concentrated form and, if remained unchecked, can result in hyponatremia (Davenport, 2004a). Each citrate ion produces three bicarbonate ions which, when metabolised by the liver may act as a buffer against metabolic acidosis or replace bicarbonate lost in the ultrafiltrate, but can cause a transient metabolic alkalosis to develop (Abramson & Niles, 1999). If metabolism by the liver is slow and clearance through the haemofilter is insufficient, citrate can accumulate in the systemic circulation leading to the development of a metabolic acidosis. As a consequence of citrate accumulation total calcium serum levels may become elevated and mask a drop in ionised calcium levels (Abramson & Niles, 1999). If levels are not supplemented hypocalcemia may occur and normal systemic coagulation is affected. The presence of significant liver impairment will limit the metabolism of citrate and makes citrate unsuitable in patients with acute liver failure (Davenport & Tolwani, 2009).

The use of citrate restricted to the CRRT circuit is an effective anticoagulant to sustain circuit life whilst the adverse consequences of patient anticoagulation are avoided. In choosing the option of citrate the complexity of CRRT is increased and requires extra training and vigilance in its application (Davenport & Tolwani, 2009). If solutions suitable for citrate administration are not commercially available the preparation of specific dialysate solutions and replacement fluids is a labour intensive procedure. To enable citrate to be used safely the monitoring of blood pH and the detection of electrolyte imbalances is also required.

Apprehension over increased treatment complexity and the risks of metabolic complications has not seen the widespread use of citrate in Australia. Studies which have reported longer circuit life (Kutsogiannis, et al., 2005; Monchi, et al., 2004) and reduced incidence of bleeding (Betjes, Oosterom, & Wetering, 2007) demonstrate

citrate has several clinical advantages over heparin. A cost-benefit analysis between the use of heparin and the more expensive option of citrate has not been evaluated in any comparative study, but the extra cost incurred using specific dialysate solutions and replacement fluids might be offset by a decrease in the quantity of circuits used and the number of blood transfusions required. The use of simpler protocols and increased availability of suitable commercial solutions may see the use of citrate achieve a wider acceptance and challenge heparin as the preferred anticoagulant for CRRT in patients at low-risk of bleeding.

Platelet-Inhibiting Agents.

Prostacyclin (PGI₂) and its synthetic derivative Epoprostenol prevent platelet aggregation and adhesion by inhibiting the formation of fibrin, leukocyte and platelet-based microaggregates (Shulman, et al., 2002). The anticoagulant properties of PGI₂ do not affect the intrinsic clotting pathway and can be used to augment the effects of heparin (Scheeren & Radermacher, 1997). Prostacyclin is initially administered systemically through a central line starting at 0.5ng per kg per min. The dose is gradually increased to a maximum rate of 5ng per kg per min (Davenport, 1998). On commencement of CRRT the PGI₂ infusion is then administered through the extracorporeal circuit. Prostacyclin is added to the CRRT circuit just as the blood exits the outflow lumen of the venous catheter. This is to maximise the time PGI₂ mixes with the blood for platelet deactivation to occur along the extracorporeal circuit (Shulman, et al., 2002).

Prostacyclin as an alternative or in combination with heparin has been shown to be an effective anticoagulation strategy for maintaining the life of the circuit in CRRT (Canaud et al., 1988; Davenport, Will, & Davison, 1994; Fiaccadori et al., 2002; Langenecker et al., 1994; R. Ponikvar, Kandus, Buturovic, & Kveder, 1991). Langenecker and associates (1994) compared the efficacy and safety of PGI₂ against heparin and the effect when both were used together in a prospective, randomised, controlled trial. No major bleeding complications were reported in either group but differences in haemodynamic instability, circuit longevity and solute removal were observed. As the sole antithrombotic agent, the authors observed PGI₂ was associated with increased haemodynamic instability when compared to heparin or heparin combined with PGI₂. After comparisons were made with the use of PGI₂ on its own or in combination with heparin, circuit life was extended when compared with circuits' anticoagulated with only heparin. A reduction in the incidence of bleeding as well as an

extended circuit life was also observed during a comparative study of PGI₂ versus heparin in patients with acute renal and hepatic failure (Davenport, et al., 1994).

A test dose of PGI₂ is usually given directly to the patient during the preparation for CRRT as a precautionary measure before a maintenance dose is delivered through the circuit. The response to PGI₂ can vary among patients with reports of vasodilatory effects causing hypotension and pulmonary shunting leading to hypoxaemia (Davenport, Will, & Davison, 1990a). Prostacyclin has a short half-life of only minutes with the unwanted vasodilatory effect rapidly reversed when the infusion is stopped, but the inhibition of platelet activation can remain for several hours (Tolwani & Wille, 2009). Should major bleeding occur unexpectedly the antiaggregating effect of PGI₂ may need to be reversed with the administration of fresh platelets. The cost of a PGI₂ infusion over 24 hours is more expensive than standard heparin (Davenport, 2004a) and the cost of a circuit change (Bellomo & Ronco, 2002a; Schetz, 2001). In view of possible hypotension increasing vassopressor requirements and the extra cost incurred when compared with other anticoagulants the use of PGI₂ has been reserved for specific clinical situations. The addition of PGI₂ combined with heparin may be useful in extending circuit life when continuity of treatment has been affected by premature clotting (Kozek-Langenecker et al., 1998; Langenecker, et al., 1994). It should also be considered instead of heparin for patients at risk of bleeding (Davenport, et al., 1994; R. Ponikvar, et al., 1991).

Thrombin Antagonists.

Recombinant (r) hirudin is a thrombin inhibitor independent of cofactors and not inactivated by PF4 which acts on bound and unbound thrombin of specific clinical value in patients diagnosed with HIT type II (Greinacher et al., 1999). Administration of r-hirudin in CRRT can either be by continuous infusion or delivered in the form of regular bolus doses (Fischer, van de Loo, & Bohler, 1999; Kern, Ziemer, & Kox, 1999). The effect on coagulation is able to be measured by recording the patient's aPTT. However, a linear relationship between r-hirudin and its anticoagulant effect is only sensitive when the plasma concentration of r-hirudin is low (Nurmohamed et al., 1994). A more sensitive measurement is the Ecarin Clotting Time (ECT) which uses the prothrombin-activating enzyme ecarin to monitor the concentration of r-hirudin plasma levels (Potsch et al., 1997).

Several authors have reported using r-hirudin successfully in critically ill patients diagnosed with or suspected of having developed HIT type II as an alternative agent to anticoagulate the circuit during CRRT (Fischer, et al., 1999; Hein et al., 2001; Kern, et al., 1999). Fischer and associates (1999) studied the use of r-hirudin to maintain circuit patency during CRRT on a number of medical patients suspected of having HIT type II. The authors reported a continuous infusion of r-hirudin 0.006 to 0.025mg per kg per hr, or regular bolus doses of 0.007 and 0.04mg per kg, was not associated with obvious bleeding or an increase in blood transfusion requirements. Kern and associates (1999) reported several episodes of major bleeding which were life-threatening in patients diagnosed with HIT type II, who required CRRT following cardiac surgery, having received r-hirudin at 0.01mg per kg per hr as a continuous infusion. The increased risk of haemorrhage being greater in surgical patients than in medical patients may explain why bleeding occurred in this study when r-hirudin was administered continuously. Hein and associates (2001) compared the use of continuous r-hirudin with continuous heparin administration using ECT assays to monitor the anticoagulatory effect of r-hirudin targeting an ECT of between 80s and 100s. The authors demonstrated the use of r-hirudin in CRRT to be just as effective as heparin in anticoagulating the circuit with no statistical significant difference in circuit life reported. Although bleeding complications causing a drop in the patient's haemoglobin was associated with r-hirudin administration compared with no bleeding in patients who received heparin, severe coagulation disorders was suggested as the cause of bleeding rather than r-hirudin accumulation. In a similar study no bleeding complications were observed when r-hirudin was administered intermittently as a 0.002mg per kg bolus dose and a target ECT of less than 80s maintained. A decrease in circuit life was observed when compared to circuits anticoagulated with continuous heparin but was not shown to be statistically significant (Hein et al., 2004).

Specific ECT assays are required which may not be generally available to monitor the anticoagulatory effect of r-hirudin accurately for exact dose adjustment (Nowak & Bucha, 1996). The effect of r-hirudin has also the potential to accumulate in the presence of renal failure as it is almost exclusively eliminated by the kidney. The half-life of r-hirudin is normally one to two hours but is considerably prolonged in patients with renal insufficiency (Fischer, 2002). The molecular weight of r-hirudin is 6980Da with only negligible removal of the molecule by diffusion (Schetz, 2001) and transfer by convection according to the sieving coefficient of the membrane (Frank,

Farber, Lanzmich, Floege, & Kierdorf, 2002). These factors can cause the concentration of r-hirudin plasma levels to become elevated and the risk of bleeding considerably increased. Should bleeding occur no specific antidote is available (Davenport, 2004a).

No Anticoagulation.

Anticoagulation may need to be withheld during CRRT for it to operate safely in patients at risk of bleeding due to a severe coagulopathy or recent haemorrhage. Bellomo and Ronco (2002a) suggest no anticoagulation should be used in patients who have a platelet count of $< 50,000$, an International Normalised Ratio (INR) > 2.0 , an aPTT $> 60s$ or who are actively bleeding or have had a haemorrhagic event in the previous 24hr.

In a prospective observational study of patients at high-risk of bleeding CRRT was shown to operate without anticoagulation and achieve similar circuit life, when a comparison of circuit life was made of circuits anticoagulated with low-dose heparin or regional heparin-protamine anticoagulation (Uchino, Fealy, et al., 2004). The mean circuit life among patients who received CRRT without anticoagulation was 19.3 hr compared to a mean circuit life of 20.9 hr and 21.2 hr using low-dose heparin or regional heparinisation.

The use of saline flushes to promote circuit life should be considered when CRRT is performed without circuit anticoagulation. Using this strategy relies on regular flushing with isotonic saline through the circuit to remove procoagulant substances. In a prospective comparative study the no anticoagulation group of patients had a baseline aPTT $> 55s$ and received saline flushes (100 to 150ml) every 30 min (Nagarik, Soni, Adikey, & Raman, 2010). The authors observed patients who were anticoagulated following a normal coagulation profile reached a similar circuit life as the no anticoagulation group of patients who had received saline flushes through the circuit (anticoagulation group 26hr $SD\pm 6.4$ versus no anticoagulation group 24.5hr $SD\pm 6.36$, P-value = NS). Based on these findings saline flushes was an effective strategy for promoting circuit life in patients who were at risk of bleeding when the use of anticoagulants was contraindicated.

Under the trade name of Xigris recombinant human activated protein C (rhAPC) or Drotrecogin alfa (activated), is a potent thrombin antagonist which has been shown to reduce patient mortality in severe sepsis (Bernard, et al., 2001). The development of

septic shock is often associated with AKI and the requirement for renal support included as part of the recovery process (Uchino, et al., 2005). Activated protein C inhibits the generation of thrombin and modulates coagulation and inflammatory reactions which can serve a dual purpose for the prevention of blood clots in the extracorporeal circuit. As a result the use of other anticoagulants to sustain circuit life during CRRT may not be necessary for patients with sepsis who require rhAPC (Abbenbroek et al., 2004; de Pont et al., 2003).

Anticoagulation-free CRRT is an option which should be considered in patients who have a co-existing coagulopathy or in patients who have had recent trauma or surgical wounds. The duration of circuit life without anticoagulation will be improved when there is good vascular access, adequate blood flow is maintained, and replacement of fluid is delivered before the haemofilter (Tan, Baldwin, & Bellomo, 2000).

A summary of the agents and strategies which are used in Australia to anticoagulate the CRRT circuit are presented in Table 2.6.

Table 2.6:

A summary of the mode of action and major advantages and disadvantages of anticoagulants used in Australia to anticoagulate the CRRT circuit

Anticoagulant	Mode of Action	Advantages	Disadvantages
Unfractionated heparin.	Effect is primary exerted on antithrombin III to block the action of thrombin and factor Xa.	Widely available and relatively inexperienced. Clinicians are familiar with dosing and monitoring considerations. Short-half-life. Effects quickly reversed with protamine.	Considerable variability in dosing occurs between patients. Allergic reaction: HIT type II. Increased risk of systemic haemorrhage.
Regional heparinisation (unfractionated heparin-protamine).	Maximises the effect of heparin on blood inside the haemofilter and along the circuit.	Anticoagulant effects of heparin restricted to the extracorporeal circuit, reduces the risk of systemic patient bleeding.	Protamine administered systemically to reverse the effects of heparin may cause hypotension.
Low-molecular weight heparins (LMWHs) and heparinoids (Danaparoid).	Inhibits the action of factor Xa whilst the effect on antithrombin III is reduced.	Anticoagulant response more reliable and predictable than heparin. Reduced risk of systemic haemorrhage. Incidence of HIT type II less likely to occur. Reversal with protamine is only partial.	Special coagulation assays are required to monitor factor Xa activity. The effects and half-life of LMWHs vary depending on the type used. More expensive than standard heparin.
Regional citrate (citrate-calcium).	Interrupts activation of the clotting cascade and platelet aggregation by the chelating of ionised calcium.	Avoids systemic anticoagulation. The risk of HIT type II is avoided.	Labour intensive procedure. Hospital pharmacies can incur additional costs associated with the preparation of solutions if trisodium citrate and modified dialysate/replacement fluids are not commercially available.

Table 2.6(Cont'd):

Anticoagulant	Mode of Action	Advantages	Disadvantages
			Requires careful monitoring of blood pH and electrolyte balance. Potential for metabolic alkalosis, hypernatraemia and ionised hypocalcaemia due to citrate toxicity. Contraindicated in patients with liver insufficiency.
Platelet-inhibiting agents (Prostacyclin).	Prevents platelet aggregation and adhesion by inhibiting the formation of fibrin, leukocyte and platelet-based microaggregates.	Can be used to augment the effects of heparin.	Unwanted vasodilatory effects causing hypotension. Expensive.
Thrombin antagonists (recombinant hirudin).	Acts on bound and unbound thrombin independent of cofactors and PF4.	Can be used in patients with or suspected of having developed HIT type II.	Clinical experience limited. Half-life is considerably prolonged in patients with renal insufficiency.
No anticoagulation.		Reduces the risk of haemorrhage in patients who have a co-existing coagulopathy, liver failure, recent trauma or surgical wounds.	Early clotting of the circuit may occur and shorten circuit life.

Replacement Fluid – administration site in the extracorporeal circuit

The volume of plasma water lost during CRRT depends upon the treatment mode selected with a larger volume of fluid removed when solute clearance is accomplished by convection as opposed to the alternative method of diffusion (Ronco & Levin, 2005). To compensate for the loss of plasma water the administration of replacement fluid containing electrolytes is required when ultrafiltrate is produced using convective-based techniques. The ratio of ultrafiltrate flow (QF) to blood flow (QB) describes the filtration fraction arrived at during ultrafiltration and changes in the ratio between QB and QF will influence the extent of haemococoncentration which occurs as blood travels through the circuit (Joannidis & Oudemans-Van Straaten, 2007). Using a treatment dose of 35ml per kg per hr with a body weight of 80kg the amount of ultrafiltrate required in one hour is 2,800ml. If the flow rate is set at 200ml per min the volume of blood passing through the circuit will reach 15,000ml per hr (200mL x 60min). The ratio of QF (2,800ml per hr) to QB (15,000ml per hr) achieves a filtration fraction of 18.6% ($2800 \div 15000 \times 100$). An optimal filtration fraction which minimises haemoconcentration has not been defined in clinical studies, but a filtration fraction greater than 30% is considered to increase the likelihood of clotting within the haemofilter (Clark, Turk, Kraus, & Gao, 2003). Adjustment of the filtration fraction can also be made by monitoring the patient's haematocrit ($Ht_{PATIENT}$) (Joannidis & Oudemans-Van Straaten, 2007). Although several factors contribute to the viscosity of blood the haematocrit (Ht) value is the major determinant and many blood analysers will allow measurement at the bedside. The measurement obtained can be used to achieve a target post-haemofilter haematocrit (Ht_{FILTER}) of 0.4 and calculate the minimum QB required for the prescribed QF ($Ht_{FILTER} = QB \times Ht_{PATIENT} / [QB - QF]$, $QB = QF \times [Ht_{FILTER} / (Ht_{FILTER} - Ht_{PATIENT})]$).

Pre-dilution

The replacement of fluid and electrolytes during CRRT can be delivered before the haemofilter using the pre-dilution method (Dirkes, 2000). Using the pre-dilution method of fluid replacement ultrafiltrate volumes are not constrained by higher plasma water losses as the removal of plasma water is counterbalanced by the effect of diluting blood prior to entry into the haemofilter. The approach allows larger ultrafiltrate volumes to be set without increasing the filtration fraction and the extent of haemoconcentration inside the haemofilter (Clark, et al., 2003). Adequate volumes of ultrafiltrate can also be achieved in situations of reduced blood flow when the slower

rate would otherwise impose an excessive increase on the filtration fraction and cause early circuit failure from premature clotting. The dilution of blood can similarly be useful as a way to reduce the level of anticoagulation required to sustain circuit life, or the effect of anticoagulation and dilution used together by adding citrate to the replacement fluid (Baldwin, 2007).

Post-dilution

The alternative approach for the replacement of fluid and electrolytes lost during ultrafiltration is by the post-dilution method (Dirkes, 2000). Using the post-dilution method solute clearance is able to be optimised since the concentration of solute in plasma is not diluted when the replacement of fluid is delivered after the haemofilter. The advantage of reducing blood viscosity is forfeited using the post-dilution method and can negatively impact on circuit longevity after elevation of the filtration fraction occurs when the ultrafiltration rate is increased to improve solute clearance. A prospective observational study undertaken by Uchino and associates (2003b) recorded circuit life when 33 patients who required CVVH received the pre-dilution method of fluid replacement. After practice had changed at the study site to the post-dilution method a comparison of circuit life was made with 15 patients who had received the alternative method of fluid replacement. The authors observed the pre-dilution of blood before the haemofilter delayed clotting and improved the duration of circuit life compared with post-dilution of blood after the haemofilter (median circuit life: 18hr versus 13hr, P-value = 0.021). A similar observation was made by van der Voort and colleagues (2005) when 16 patients received CVVH using the alternative method of fluid replacement during a randomised crossover study (median circuit life: 45.7hr versus 16.1hr, P-value = 0.005). Although both of the studies demonstrated superior circuit life using the pre-dilution method of fluid replacement the approach was associated with inconclusive observations regarding whether the method caused a reduction in solute clearance. The median creatinine clearance achieved by van der Voort and associates (2005) was significantly higher using the post-dilution method (45ml/min) than observed with pre-dilution fluid replacement delivery (33ml/min, P-value = 0.001). A reduction in the daily SCr value was in contrast not observed by Uchino and associates (2003b) to have changed significantly during the interval patients received replacement fluid using the post-dilution method (7.9% versus 10.2% per day, P-value = 0.99). As a strategy to reduce blood viscosity and promote circuit life, preference should be given to the replacement of fluid and electrolytes using the pre-

dilution method. Despite the improved solute clearance associated with post-dilution, the ultrafiltration volumes required using the pre-dilution method can be increased as a compensatory measure. The possibility of increased circuit life will in turn improve the ability to deliver the desired treatment dose within a 24-hour period.

Theoretical and Operational Training

A comprehensive training programme is required to ensure nursing staff receive adequate instruction on the theoretical and operational aspects of CRRT (Baldwin, 2007). The degree of effectiveness in treatment delivery and duration of circuit life can be influenced by staff that are not sufficiently trained or experienced in the application of the technique. Out of the 34 hospitals who responded to a survey undertaken in Canada, 31 (91%) indicated the existence of a dedicated training program for ICU nurses in the management of patients requiring CRRT (Langford, Slivar, Tucker, & Bourbonnais, 2008). In the development of a training programme several approaches are recommended by Baldwin (2007). Lectures presentations or self-directed learning packages are useful strategies to explain the basic concepts of CRRT with extra reading material supplied for future reference. The expertise required to operate CRRT successfully can be acquired by hands-on training and supervision using equipment at the bedside. It is also important that nurses at the bedside have access to evidence-based protocols and practice guidelines which are consistent with recommendations made in the literature. Once a training programme has been established regular assessment of clinical standards assist in maintaining expertise and help identify areas of practice where improvements can be made (Richardson, Reynolds, & Rodgers, 2006). The regular auditing of nursing staff to ensure competency in the use of CRRT should also include the recording of circuit life (Baldwin, 2007). This has been made easier following the introduction of CRRT machines which allow the critical care nurse to monitor circuit pressures continuously and to observe signs of deterioration in circuit function.

Monitoring Circuit Pressures.

The monitoring of extracorporeal circuit pressures can assist with the early detection of blood clots and can serve as a useful indicator of imminent circuit failure. The resistance to blood flow along the extracorporeal circuit increases over time when the veno-venous pump speed is held constant. A drop in pressure between the top and bottom of the haemofilter was shown by Holt and associates (1996) to be predictive in filter clotting when pre-filter (P-IN) and post-filter (P-Venous) circuit pressures were

monitored. The increasing difference in pressure as blood enters and leaves the haemofilter is caused by increased resistance as the result of microclotting in the hollow fibres of the haemofilter. New purpose-built CRRT machines have circuit pressure pods and computer software which allows the operator to monitor the pressure drop and other pressure changes that occur during the life of the extracorporeal circuit. The trans-membrane pressure (TMP) is a derived pressure calculated from the difference in pressure exerted along the membrane between the blood and fluid compartments within the haemofilter. A gradual rise in TMP indicates the pores along the membrane are clogging-up with blood clots and increases in pressure required for plasma water and solutes to move across the membrane (P-UF). The monitoring of access pressure measures the degree of difficulty in establishing a negative force sufficient to achieve adequate blood flow from the patient access catheter and return pressure, a positive force which increases due to the accumulation of blood clots along the return line of the circuit. Observations made by Ejaz and associates (2007) showed distinct patterns in circuit pressure emerged and could be linked to different parts of the circuit or events during the life of the circuit which were susceptible to changes in blood flow or clotting.

Circuit Design

The design of the CRRT circuit has since its inception moved away from circuitry which allowed blood to pass through the haemofilter under the influence of arterial blood pressure, to a technique that uses a roller pump to control the flow of blood through a double lumen venous catheter. Differences in the design of the veno-venous circuit to accommodate the roller pump and the requirement for a venous bubble trap to remove air pockets from blood lines have been associated with a reduction in circuit life compared to non-pumped techniques (Davenport, 1998; Schetz, 2001). Despite the suggestion of a reduction in circuit longevity, the pumped veno-venous technique provided superior solute clearance (Macias, Mueller, Scarim, Robinson, & Rudy, 1991; Storck, et al., 1991) and did not require arterial cannulation (Bellomo, 1996), prompting the widespread adoption of this technique in Australia (Silvester, et al., 2001) and Europe (Liano, et al., 1998; Wright, et al., 2003). As shown in Figure 2.11 the key areas of the veno-venous circuit which activate the coagulation pathway and lead to the development of blood clots are the roller-pump, the haemofilter and the venous bubble or air-trap (Davenport, 1997).

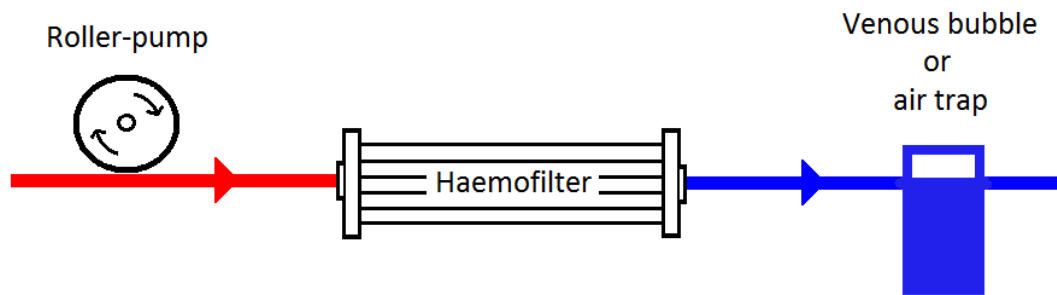

Figure 2.11. Key areas of the veno-venous circuit which activate the coagulation pathway and lead to the development of blood clots.

Roller Pump

The CRRT machine uses a motorised roller-pump to draw blood from the vascular access catheter through the circuit according to the speed regulated by the operator (Baldwin & Bellomo, 2004). The action of the pump causes compression of the circuit surrounding the roller head and during rotation blood is ‘squeezed’ through the tubing. A pattern of peristaltic blood flow occurs at this segment of the circuit and the turbulence which is thought to cause platelet activation, the release of clotting factors and damage to red blood cells (Davenport, 1997).

Haemofilter.

On entry into the haemofilter blood is directed through numerous hollow fibres which make up the blood compartment of the haemofilter. Spaces between the fibres make up the fluid compartment of the haemofilter which allows the movement of plasma water and solutes out of the blood compartment to be transported across the membrane of each hollow fibre. As blood travels along the hollow fibres, the surface area of the membrane attracts plasma proteins and causes activation of the coagulation pathway, leading to the formation of blood clots (Davenport, 1997). Laminar flow within the haemofilter is interrupted causing the passage of blood inside each hollow fibre to become turbulent increasing the tendency for clotting to occur.

The physical properties of the haemofilter play an important role in reducing the resistance to blood flow and as a result may improve the performance of the device. Differences in the way fibres are configured within the haemofilter can facilitate less turbulent blood flow. Haemofilters consisting of hollow fibres tolerate the higher pressure forces generated by the speed of blood flow through the circuit when veno-

venous CRRT systems are used (Baldwin, Bridge, & Elderkin, 1998). The resistance to blood flow is theoretically reduced when the design of the haemofilter allows the number of fibres to be increased, the length of each fibre is made short, and the inner diameter of the haemofilter has a large cross-sectional area (Jenkins, 1998). This approach for reducing the resistance to blood flow and the pressure drop as blood enters and leaves the haemofilter was not supported in a prospective randomised cross-over study. Using two polysulfone haemofilters investigators evaluated the operational characteristics of each device during CVVH according to differences in length and number of fibres (Dungen, von Heymann, Ronco, Kox, & Spies, 2001). The authors found the haemofilter composed of longer hollow fibres recorded lower TMP measurements and extended circuit life which was significantly different when the same measurements were taken using the shorter length haemofilter with a wider cross-section of fibres (TMP 106mmHg versus 194mmHg, P-value = 0.02 and circuit life 1276min versus 851min, P-value = 0.04). Although the increased number of fibres may have decreased the pressure drop within the haemofilter, Dungen and associates (2001) suggest the impact of a slower blood flow due to a wider cross-section of fibres may have increased blood viscosity and caused greater resistance to blood flow. The authors only investigated differences in length and number of fibres with the surface area for solute clearance remaining the same between each of the haemofilters studied. A larger surface area could in theory improve the performance of the haemofilter by reducing the rate at which pores of the membrane become clogged with trapped proteins and lessen the rate hollow fibres start to develop blockages due to the presence of blood clots (Joannidis & Oudemans-Van Straaten, 2007). In another controlled study the surface area of the haemofilter was allocated differently among patients who received CVVH after comparisons were made of circuit life according to the size of the membrane surface area (Baldwin, Tan, Bridge, & Bellomo, 2002). A surface area of 0.75m² versus 1.3m² was not shown by the authors to significantly hasten membrane fouling and clotting of the fibres which shortened the lifespan of the circuit (0.75m² surface area mean circuit life 15.75hrs SD±14.3 versus 1.3m² surface area mean circuit life 16.8hrs SD±13.1, P-value = 0.972).

The haemofilter is packed with fibres constructed from materials which provide membrane technology among the most haemocompatible of all membranes used for extracorporeal RRT. Activation of the coagulation pathway is influenced by the interaction which occurs between the blood and membrane surface area (C. H. Jones,

1998). How quickly blood clots develop within the haemofilter will depend on the electro-negativity of the membrane, the capacity of the membrane to adsorb plasma proteins and the reaction of the complement system to substances present in the membrane. In one study polyacrylonitrile membranes were shown to have only a negligible effect on platelet aggregation and activation of the intrinsic coagulation pathway (Salmon, et al., 1997). The observations made showed no change in levels of contact factors when regular blood sampling was undertaken over the lifespan of the circuit. Modification to existing synthetic membranes has seen the introduction of haemofilters where the membrane is coated with heparin designed to minimise activation of the coagulation pathway. Heparin-coated membranes were shown to require less heparin administration but achieve longer circuit life when heparin requirements were compared with non-heparin-coated membranes (Sieffert, Mateo, Deligeon, & Payen, 1997). The use of synthetic membranes can improve the overall haemocompatibility of the haemofilter and should always be considered as a strategy to promote circuit life. An extra benefit may also be gained using membranes which are impregnated with anticoagulation properties.

Venous bubble or air-trap.

The function of the venous bubble or air-trap, located after the haemofilter as shown in Figure 2.7, is to prevent an air-embolus from occurring should air inadvertently enter the extracorporeal circuit. Air is collected inside the chamber before blood is returned to the patient. Gretz and colleagues (1995) reported a reduction in the formation of blood clots when the blood-air contact in the chamber was reduced. The authors reduced blood-air contact by elevating the blood level inside the chamber above the blood inlet line so that circulating blood was not exposed to air and the appearance of blood sedimentation created a plasma seal. A similar effect can be achieved when a continuous infusion of isotonic fluid (0.9% saline) is delivered into the chamber. The administration of anticoagulant agents directly into the venous bubble was not shown to modify the effect of blood-air contact and protect the site from clotting (Baldwin, et al., 2002). In this study the authors reported no difference in circuit life or clotting inside the venous chamber when the delivery of heparin was divided equally between the venous chamber and pre-filter infusion site, or when compared to the same dose of heparin after the anticoagulant was administered entirely through the pre-filter infusion site.

Venous Access Catheter

A common cause of circuit failure during CRRT is as a result of a lack of understanding on how catheter design can lead to poor blood flow and clotting (Bellomo & Ronco, 2002c). Vascular access for CRRT is achieved using non-cuffed, non-tunnelled, dual-lumen catheters to access blood flow from a central vein. During placement of the venous catheter, the degree of damage to the distal tip and injury to the surrounding tissues of the insertion site result in activation of the coagulation pathway, increasing the likelihood of premature clotting within the access device (Davenport, 1997).

The most widely used dialysis catheters for temporary vascular access are made from biocompatible polyurethane and silicone materials that are associated with less reaction and incidence of venous thrombosis when inserted into a central vein (Canaud et al., 1998). Whilst silicone catheters are more flexible and reduce the risk of vascular perforation, the added strength of semi-rigid polyurethane catheters results in easy insertion without cut down to the vein, a larger internal lumen that facilitates higher blood flows, and after exposure to body temperature softening of the catheter reduces tissue damage at the insertion site (Oliver, 2001).

The internal pathway of the venous catheter should allow for laminar blood flow and limit turbulence. Veno-venous catheters feature a double-lumen design to direct blood flow through two separate parallel channels. The layout of the blood outflow and return lumen and configuration of the distal tip differ in several types of catheters. As shown during an ex-vivo laboratory study different catheters offer resistance to blood flow which may be variable (Tan, Bridge, Baldwin, & Bellomo, 2002). The difference relates to the shape of the lumen, commonly cylindrical and side by side, or in a non-cylindrical 'D' shape. Data extrapolated from patients receiving IHD found superior blood flow occurred in catheters comprising of two round cylindrical internal lumina when compared with catheters which had a shared common middle wall. The inferior blood flow was observed despite the D-shaped lumina catheters occupying a larger internal diameter (Atherikul, Schwab, & Conlon, 1998).

The outflow lumen of catheters with side holes may cause the area adjacent to the tip to lie against the blood vessel wall, particularly when higher blood flow rates generate significant negative pressure at the inflow ports; this can result in a reduction in blood flow (Chrysochoou, Marcus, Sureshkumar, McGill, & Carlin, 2008).

Disconnecting the outflow and inflow blood lines from the double lumen catheter and switching them over may improve blood flow if resistance to aspiration on the inflow lumen is less compared with when blood is drawn from the outflow lumen. Similarly, rotating the catheter through the skin at the insertion site can realign the side holes of the distal tip in order to establish sufficient blood flow.

Vascular Insertion Site

A number of factors influence the selection of the vascular access catheter insertion site. The femoral vein site is selected when respiratory conditions may preclude intrathoracic cannulation but is also useful in patients who are nursed in the supine position (Canaud, Desmeules, Klouche, Leray-Moragues, & Beraud, 2004). This site is often used for critically ill patients who are sedated and mechanically ventilated. As the largest easily accessible vein, the femoral site will usually deliver better blood flow, provided the catheter is not kinked due to hip flexion when the patient is repositioned (Baldwin, et al., 1998). Should it be necessary to commence CRRT without delay, access to the femoral vein is technically easier during the insertion of the catheter and may be the preferred cannulation site (Canaud, et al., 1998). The increased risk of infection due to the close proximity of the femoral site to the perianal and genitalia region of the body is sometimes suggested as a reason why other venous access sites are selected instead. A multi-centre RCT involving 750 patients reported the colonisation of the femoral catheter was not significantly different when a comparison was made of catheters removed from the jugular venous site (incidence of 40.8 versus 35.7 per 1000 catheter-days; hazard ratio [HR], 0.85; 95% CI, 0.62-1.16; P-value = 0.31). Sub group analysis did show that patients with a high body mass index had a significantly higher rate of colonisation in femoral lines as opposed to jugular catheters (50.9 versus 24.5 per 1,000 catheter-days) (Parienti et al., 2008). The ability to keep the area around the femoral catheter site clean is sometimes not easy to achieve particularly in obese patients and the prevention of insertion site contamination made more difficult in situations of faecal incontinence.

Cannulation of the subclavian or internal jugular vein is considered for patients who are more mobile (Uldall, 1996). Both sites allow easier access for inspection should interruptions to blood flow occur (Baldwin, et al., 1998). Inadequate blood flow can result if the subclavian vein is chosen due to the curving of the catheter under the clavicle and the potential for the catheter tip to lie against the superior vena cava wall. This is less problematic if the catheter is inserted into the jugular vein from the right

side as the catheter has a natural tendency to lie parallel rather than against the vein wall, with interruptions to blood flow less likely to occur (Bellomo & Ronco, 2002c). Intrathoracic catheters may experience reduced blood flow if supra cardiac central filling pressures are low in patients receiving positive pressure ventilation, or if the patient is hypovolaemic and sat in an upright position (Baldwin, et al., 1998). When catheters are placed in the thoracic veins, coughing can also elevate intra-thoracic pressure and intermittently affect blood flow.

Various catheter lengths assist in the alignment of the distal tip into the correct position to secure adequate blood flow, whilst the internal diameter of the catheter influences the degree of resistance to blood flow. Bellomo and Ronco (2002c) recommend the length of the catheter should be at least 20cm when the femoral vein site is chosen. This is to allow the tip to be positioned in the inferior vena cava where the greatest blood flow is located. The authors also prefer to use catheters with large 13.5 French Gauge internal diameters designed without side holes at the distal end of the catheter. The position of the catheter tip using the subclavian or internal jugular access site is controversial with placement at the discretion of the treating intensive care specialist. The desire for optimal catheter performance would indicate the location of the catheter in the right atrium as the preferred option. The alternative approach of the catheter tip situated close to the atrial junction in the superior vena cava may be unable to maximise blood flow but the patient is not exposed to the same risks of cardiac perforation and tamponade, cardiac arrhythmias and increased incidence of catheter-induced thrombosis which can occur when the tip is placed in the right atrium (Vesely, 2003).

Blood Flow

A contributory factor to variations in circuit life is the rate at which blood is circulated through the circuit causing an increase in the tendency for the circuit to clot when blood flow is reduced. Whilst lower flow rates are appropriate when smaller diameter circuits are used, such as in paediatric patients, likelihood of the circuit clotting is increased when standard adult tubing is used, if blood flow is allowed to fall below 100ml per minute (Kox, Rohr, & Waurer, 1996). A recommendation by Baldwin and associates suggest the rate of blood flow for CRRT should be maintained between 150 and 200ml per min (1998). Observations made during one study found a blood flow rate set above 125ml per min did not improve circuit survival time when associated with the practice and frequency of flushing the circuit using 0.9% saline (Prasad et al., 2000).

Sufficient blood flow through the circuit may not always be possible to sustain due to poor vascular access or as the result of haemodynamic instability encountered when the patient commences treatment. A study investigating the effect of stoppages or minor reductions in blood flow demonstrated circuit longevity was adversely affected and, when interruptions were severe, correlated with circuit life more strongly than the measurement of blood coagulation variables (Baldwin, et al., 2004).

In reviewing the factors which affect circuit life each one can be categorised according to whether the reasons for circuit failure was driven by a physiological or mechanical factor. The critically ill patient is often predisposed to physiological abnormalities in combination with extracorporeal circulation which cause blood to clot prematurely. How the body responds to these changes make the longevity of circuit life unpredictable, but the use of exogenous anticoagulants and the replacement of fluid before the haemofilter can have a beneficial affect on extending treatment delivery. The same improvement can be achieved when mechanical factors are considered in the relationship with circuit longevity. Several mechanical factors have been discussed which demonstrate the importance of circuit design in minimising the development of blood clots and the level of experience required by the operator to ensure the technique can be deployed successfully. A summary of the physiological and mechanical factors affecting the longevity of circuit life is shown in Table 2.7.

Table 2.7
Physiological and mechanical factors affecting circuit life

Physiological	Mechanical
Coagulation factors	Circuit design
Extracorporeal circulation and exposure to non-biological surfaces	Vascular access catheter placement (femoral, subclavian or internal jugular vein)
Viscosity of blood and level of haemoconcentration	Blood flow
Exogenous anticoagulants	Training and operator proficiency

Importance of Circuit Life

The success of CRRT is dependent on adequate circuit life to realise the benefits of the technique. Instead of the three to four hours associated with conventional IHD the scheduling of treatment using CRRT is prescribed over 24hr. Although intended to operate as a 'continuous' therapy inadequate circuit life caused by interruptions or delays in the delivery of CRRT can interfere with the effectiveness of the technique. In situations where continuity of treatment is lost during the 24hr prescription period the ability of the technique to remove excess fluid and achieve biochemical control is reduced, and the costs associated with replacing single-use components increased along with the extra workload required to set-up the circuit. The adequacy of circuit life and the impact of circuit 'down-time' on azotemic control was investigated during a prospective observational study (Uchino, et al., 2003a). When interruptions occurred in treatment delivery the total number of hours treatment was delayed impacted upon the effectiveness of CVVH to stabilise and reduce concentration levels of urea and creatinine. Univariate analyses showed there was a significant inverse correlation between treatment down-time and changes to urea and creatinine levels within a 24hr treatment cycle (P-value < 0.0001). Based on the percentage of change in solute clearance observed during the study the authors suggested an ultrafiltration of 2L per hr required a down-time of less than eight hours per day between treatments to ensure the effectiveness of the technique was maintained.

The importance of adequate circuit life has been included as a secondary if not the primary outcome measure in many studies since the introduction of CRRT into clinical practice. Attempts at making comparisons of circuit life from the literature are difficult when faced with historical differences in the setup of CRRT. This inherent disparity between old and new technologies using 'pumped' instead of 'spontaneous' circuitry is an example of the historical differences which can occur when reviewing the literature. Although not previously evaluated in a prospective randomised study differences in circuit design may have contributed to a reported reduction in circuit life using veno-venous pumped circuitry when compared with the longevity of spontaneous arterio-venous circuits. A prospective comparative study found circuit life of patients who received CAVHDF was significantly longer than the duration of circuits observed when patients were treated with CVVHDF (75.1hr versus 42.5hr; mean difference 32.6 hr; 99% CI 13.1 to 52.1; P-value < 0.01) (Bellomo, Parkin, Love, & Boyce, 1993). The decrease in circuit life observed during CVVHDF may have been the result of more

turbulent blood flow through the circuit leading to greater activation of the coagulation pathway caused by the inclusion of a roller pump and the requirement for an air trap.

The potential for extended circuit life using arterio-venous techniques has long since been overshadowed by the superiority in solute clearance of veno-venous techniques and improvements reached following advances made in circuit design technology. Investigations on the use of veno-venous techniques have reported large variations in circuit life. The duration of circuit life using CVVHD was observed in one study to be as short as three hours and as long as 117hr (Holt, et al., 1996). Out of the five patients who required 41 circuits both measurements when incorporated in the total number of circuits used resulted in a mean circuit life of 30hr. Among the patients the authors reported upon individual mean circuit life varied between 10 to 45.5hr. Other investigators have used the median value rather than the mean as being less sensitive to outliers when reporting differences in circuit life measurements. A median circuit life of 37.8hr using CVVHDF was reported by Reeves and associates when heparinised saline was used to prime the extracorporeal circuit (1997). In situations where the circuit has operated continuously for more than 48hr and caused a decline in membrane performance some authors argue that the circuit should be taken down electively (Macias, et al., 1991; Wendon et al., 1989).

The variability reported in the literature demonstrates circuit life is influenced by a combination of physiological and mechanical factors. Underlying the longevity of circuit life observed is the patient's disease and its effect on haemostasis influenced by the use of anticoagulant agents, expertise in the operation of equipment and design features of the extracorporeal circuit. The potential also exists for differences in convective versus diffusive transport mechanisms to influence circuit life. Diffusive mechanisms in solute transport have a minimal effect on plasma water removal and changes in blood viscosity in contrast to the plasma water that is removed when solute transport is by convection. As a consequence of ultrafiltration haemoconcentration occurs as blood enters into the filter and increases the haematocrit, platelet count and coagulation factors. The passage of plasma water through the membrane increases blood-membrane interaction causing more haemostatic activation. The effect of convection during intermittent haemofiltration and haemodiafiltration was shown in a prospective crossover study to be associated with increased procoagulatory activity when compared with diffusion during intermittent haemodialysis (Klingel et al., 2004). Using the same anticoagulation strategy for each treatment mode the authors reported a

significant reduction of thrombin-antithrombin III complex and D-dimer generation occurred in the extracorporeal circuit, when blood sampled from the venous lumen during haemodialysis was compared with a similar sample taken after treatment had changed to haemofiltration (thrombin-antithrombin III: P-value = 0.014, D-dimer: P-value = 0.047).

A number of studies have compared circuit life using different CRRT modes (Brophy et al., 2005; Ricci, Ronco, Bachetoni, et al., 2006; van de Wetering, et al., 1996). Observations were made using either convection-based or diffusion based techniques. Solute removal using convection relies on hydrostatic pressure and relatively high blood flows to ‘push’ through solutes in order to achieve similar clearance as diffusion which is a more passive process where solutes ‘pass’ across the membrane due to a concentration gradient. This increases the demand on convection to push through more solutes when efforts are made to achieve dose equivalence with that achieved using diffusion. A retrospective analysis of circuit life between CAVH and CAVHdf observed no difference between the two treatment modes (van de Wetering, et al., 1996). The study compared modes which are now no longer in common use or recommended when veno-venous technology is available. A prospective survey of children who required CRRT did not find a correlation between mode and duration of circuit life (Brophy, et al., 2005). The evaluation of anticoagulation practices undertaken by the authors, after reviewing the management of paediatric CRRT found circuit life was similar for CVVH, CVVHD and CVVHdf, but a meaningful comparison of circuit life was difficult to extrapolate due to different anticoagulation strategies applied to each modality. A significantly shorter circuit life was observed using CVVH than measured using CVVHD in a prospective comparative crossover study (P-value = 0.03) (Ricci, Ronco, Bachetoni, et al., 2006). The authors demonstrated circuits which were exposed to higher ultrafiltrate volumes associated with CVVH had elevated transmembrane pressure values. When this was compared with measurements recorded during CVVHD the lower pressures observed indicated a decrease in membrane interaction. The question of whether the mode of CRRT using CVVH versus CVVHdf affects circuit life has not been investigated using a prospective randomised, controlled study.

Summary

The debate over which RRT is the most appropriate to treat ARF in the critically ill patient continues to be subject of investigation. The use of CRRT is now an

established treatment option when attempts using conventional IHD have failed due to the frequency of hypotensive episodes or in patients who are haemodynamically unstable. Volume overload is managed more effectively using CRRT than conventional IHD with greater regulation of fluid balance able to improve the function of other organs. The gradual removal of solutes during CRRT is important when IHD is contraindicated in patients who have raised intracranial pressure and at risk of cerebral oedema if solutes are removed too quickly. The proposition that CRRT is superior to conventional IHD due to a number of operational advantages which are of benefit in the management of the critically ill patient, has not been able to demonstrate a corresponding improvement in patient survival and return of renal function with sufficient rigor to resolve the controversy surrounding which RRT to use.

The continuous approach to renal replacement therapy in the management of the critically ill patient with severe ARF was initially applied using arterial blood pressure to drive blood flow. The use of technology was ‘borrowed’ from conventional IHD and experience previously gained in the area of chronic renal failure adapted to suit the practice requirements of the technique intended to operate continuously. A move to veno-venous techniques using double lumen vascular access devices and the incorporation of motorised roller pumps in machines designed to overcome the shortcomings of inadequate blood pressure improved treatment efficiency but increased the complexity of the original technique. The importance of circuit life was soon realised early on in the development of CRRT. To achieve adequate replacement of renal function the maintenance of circuit life is of clinical importance since treatment dose depends upon a measure of circuit longevity. It is also an important factor in reducing the time spent by nursing staff in the preparation and set-up of CRRT, in the containment of costs associated with the usage of single-use items and to limit blood loss due to circuit failure. In the application of CRRT a number of measures are used to improve the duration of circuit life which can reduce activation of the coagulation cascade when blood is circulated outside the body leading to circuit failure. In most instances this requires some form of continuous circuit anticoagulation with unfractionated heparin the most widely used anticoagulant employed in Australia. Despite limited evidence from RCTs in support of non-anticoagulant interventions a number of measures have been put forward which can assist in reducing procoagulatory activity. Several design features of the extracorporeal circuit can reduce the incidence of premature clotting whilst the establishment of sufficient blood flow and the pre-

dilution method of fluid replacement have been successfully employed as useful strategies to promote circuit life.

An important area to consider when investigating factors which affect circuit life remains the issue concerning the mechanism of solute removal. Studies which have dealt with this issue show some relationship may exist between circuit life and the type of CRRT chosen either as a convective or diffusive treatment modality. Should a specific modality demonstrate superiority in circuit survival this would provide a clinically significant advantage to patients on CRRT with the potential to increase the amount of treatment able to be delivered.

CHAPTER 3

CONCEPTUAL FRAMEWORK

The development of a conceptual framework to guide the direction of the research project is discussed in this chapter and was used to organise various issues and concepts associated with circuit life in CRRT. The grouping of information in this way and the establishment of a conceptual view of circuit life based on the findings of the literature review supported the identification and origination of factors known to influence the longevity of the circuit. The conceptual framework also acted as a reference point and provided the basis to explain possible reasons for unexpected findings in the data observed.

Concept Mapping and the Development of a Conceptual Framework

The technique of concept mapping is used to visually represent the content of a subject and to create a conceptual framework for the process of knowledge acquisition (Novak & Canas, 2006). The conceptual framework is constructed from symbols used in the concept map which are linked together by words arranged in a hierarchical order. The visualisation of important elements that relate to a specific area of enquiry (in this case circuit life and CRRT) is a useful method to organise information and explore relationships which assist the researcher to gain new knowledge on the subject under investigation. The development of a conceptual framework on circuit life was based on physiological and mechanical factors identified in the literature review as either contributing to clotting or unexpected failure when blood flow is circulated through an extracorporeal circuit (Baldwin, 2007; Davenport, 1997; Davies & Leslie, 2006; Joannidis & Oudemans-Van Straaten, 2007; Kim, et al., 2010). Such a framework provided a structure to give direction in choosing a design methodology suitable to answer the research question and formed the basis on which to analyse and frame conclusions drawn from the data collected.

The conceptual framework shown in Figure 3.1 uses an arrow heading one-way to represent flow of blood and the portrayal of hollow tubing an interpretation of the extracorporeal circuit. On the opposite side of the tubing is an arrow pointing upwards symbolising increased blood clotting. At the bottom of the tubing is another one-way arrow representing both time and exposure to factors which affect the longevity of the

circuit. As a consequence of circulating blood outside of the body the development of blood clots occur due to the activation of the coagulation pathway and is portrayed by a gradual increase of tone from light to dark shading. The impact of physiological and mechanical factors on clotting within the circuit is represented by two rectangular boxes placed adjacent to one another. A one-way arrow links the rectangular boxes together indicating the interdependency both have with each factor and on the extent of clotting when blood travels through the circuit. The representation of circuit tubing is surrounded by square boxes which symbolise independent variables colour-coded according to whether they are physiological or mechanical in nature and the interaction that occurs with the dependent variable of circuit life.

Interdependency between Physiological and Mechanical Factors

The interdependency which occurs between the physiological and mechanical factors as already noted influences the longevity of the CRRT circuit as blood is required to circulate outside of the body. The development of ARF is a common complication of severe infection (Uchino, et al., 2007) and the successful application of CRRT in septic patients dependent on maintaining adequate circuit life. The interdependency of physiological and mechanical factors is able to be demonstrated by using the example of severe infection and the experience of the nurse allocated to care for the patient receiving CRRT.

Increased activation of the coagulation pathway is a physiological factor which occurs secondary to sepsis as part of the inflammatory response (Balk, 2000). This is present before the commencement of CRRT and already predisposes the circuit to the possibility of a shorter lifespan. A similar predisposition to early circuit failure before treatment has begun might also occur due to mechanical factors increasing activation of the coagulation pathway. The accuracy of how the circuit was assembled by the nurse may increase blood flow turbulence during operation when connections were previously not put together correctly, or the solution used to prime the circuit was incomplete and pockets of air remained in the circuit. The degree of interdependency between physiological and mechanical factors continues once treatment has commenced which can either increase or decrease the longevity of the circuit.

As blood travels through the circuit the physiological effects of sepsis on coagulation factors interact with various components of the circuit. The coagulation pathway is activated on contact with non-biological materials after exposure to the

vascular access device, during the circulation of blood by the roller-pump through plastic tubing, as blood enters the haemofilter and interacts with the membrane, and when blood comes into contact with air in the venous air-trap chamber (Davenport, 1997). The formation of blood clots is increased with the repeated passage of blood along the circuit and the effects of sepsis reducing the levels of naturally occurring anticoagulants normally present in blood. The administration of anticoagulatory agents can manipulate the physiological factor of circuit thrombogenesis in the septic patient and delay the onset of early clotting (du Cheyron et al., 2006). The viscosity of blood and the tendency to clot is increased when the ratio of ultrafiltrate to blood flow is high and excessive haemoconcentration occurs inside the haemofilter, with the dilution of procoagulatory substances a physiological factor which can promote circuit life when replacement fluid is delivered pre-filter (Uchino, et al., 2003b).

As the extracorporeal circuit begins to deteriorate over time with the development of blood clots other mechanical factors increase the physiological factors associated with coagulation. The position chosen for venous access combined with the inner diameter and pattern of blood flow created by the design features of the catheter will determine the extent of turbulence and coagulation which is generated as blood travels through the access device. The circulation of blood is driven by the action of the roller-pump and laminar blood flow interrupted when the action of the roller head causes compression of the circuit tubing. On entry the disruption of blood flow within the haemofilter is repeated again when the deposits of protein, the adhesion of platelets and the combination of red blood cells layer the membrane and obstruct blood flow. The passage of blood from the haemofilter enters another turbulent phase when blood travels to the air-trap and passes through the chamber before being returned to the patient. The extent of disruption in blood flow and degree of turbulence at different locations of the circuit is affected by the speed of the roller-pump and the degree of circuit fouling which has already occurred. The delay in trouble-shooting alarms by nursing staff inadequately trained in the operation of equipment has the potential to interrupt blood flow when alarms are not resolved quickly and intensify the existing physiological factors causing clotting blood to clot. Under these situations a slow response by the operator to changes in patient positioning or other events such as patient coughing represents a mechanical factor which can lead to the stasis of blood and excessive clotting causing earlier than expected termination of the circuit.

Longevity of the Circuit and the Conceptual Framework

The septic patient with ARF who requires CRRT demonstrates the value the conceptual framework can provide as a meaningful synthesis of information to accommodate the known factors which affect the longevity of circuit life. The multifactorial causes of premature clotting have a variable influence on circuit life and the example provided represents an extreme set of circumstances which is not always present. The physiological and mechanical factors identified in the conceptual framework are considered separately in the context of what is already known about the affect each has on circuit life. Once connections have been made in the relationships which occur between these factors strategies directed at the promotion of circuit life can be explored, and the extent of influence evaluated based on established principles displayed in the conceptual framework.

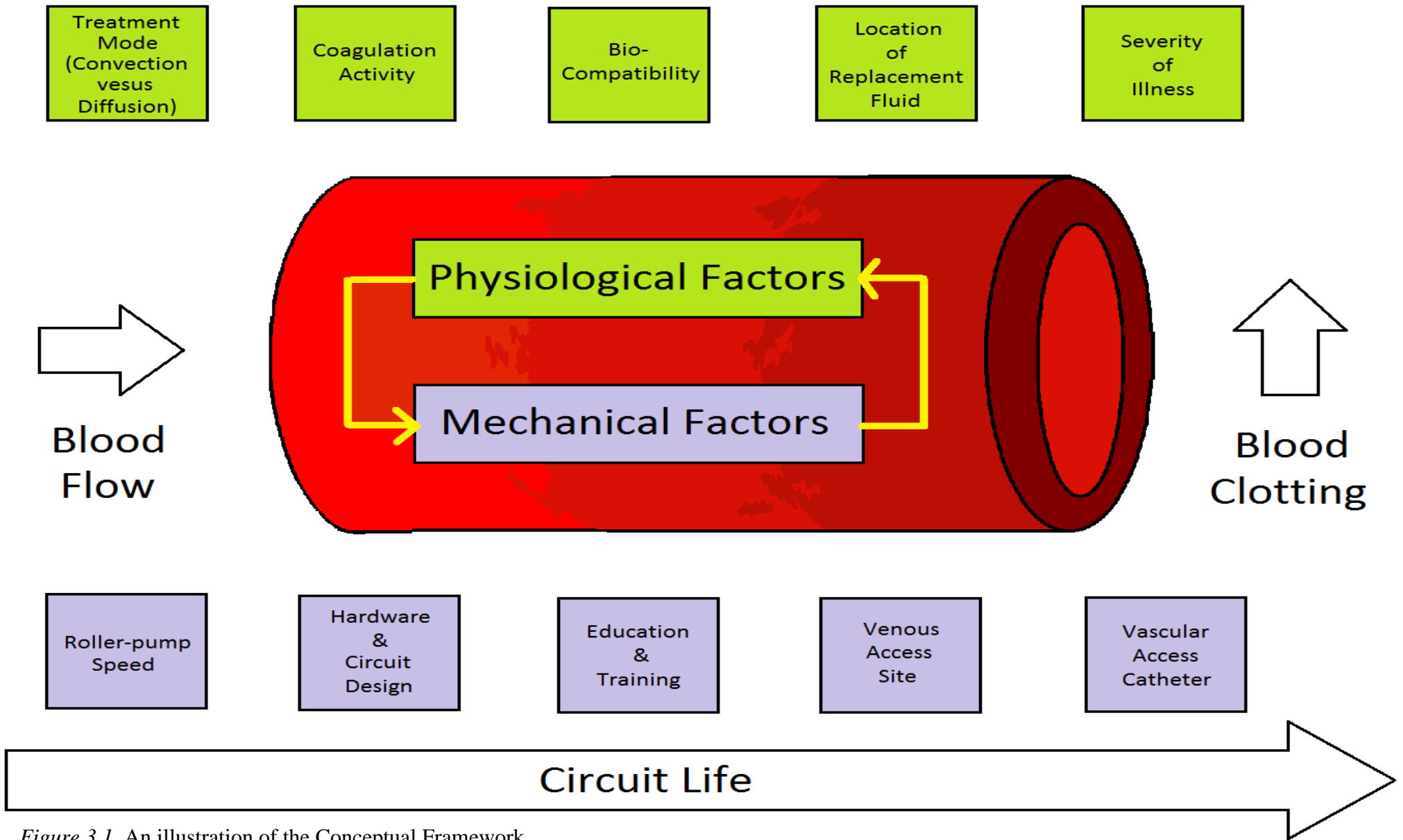

Figure 3.1. An illustration of the Conceptual Framework.

CHAPTER 4

RESEARCH DESIGN AND METHODOLOGY

The chapter is concerned with the research design and methodology used to examine the research question under investigation. A standardised approach was adopted in the reporting of the research project and followed guidelines based on the consolidated standards of reporting trials (CONSORT) statement (Begg et al., 1996). The CONSORT statement provides a checklist on the reporting of RCTs and, in describing the research design and methodology, incorporates a flowchart requiring information on how random assignment, data management and analysis of results were accomplished. Using the recommendations from the revised CONSORT statement (Moher, Schulz, & Altman, 2001), a flowchart shown in Figure 4.1 was devised to assist with compiling a report which was able to articulate the research design and methodology used for the project and how data analysis was organised for interpretation of results. This approach was adopted for the purposes of improving the ability of the reader to make informed judgements about the reliability and relevance of the research project.

Sample

The criteria for participation in the study required patients to be 18 years of age or over, admitted to the study site adult ICU and ordered CRRT as determined by the Intensive Care Specialist on duty. Patients who were unable to receive the standard heparin regimen for anticoagulation of the extracorporeal circuit, such as an existing coagulopathy or the development of HIT or recent trauma, were excluded from participating in the study. Haemostatic failure prohibiting the use of the standard heparin regimen was based on clinical assessment by the medical officer in charge of the patient. A summary of inclusion and exclusion criteria is shown in Table 4.1.

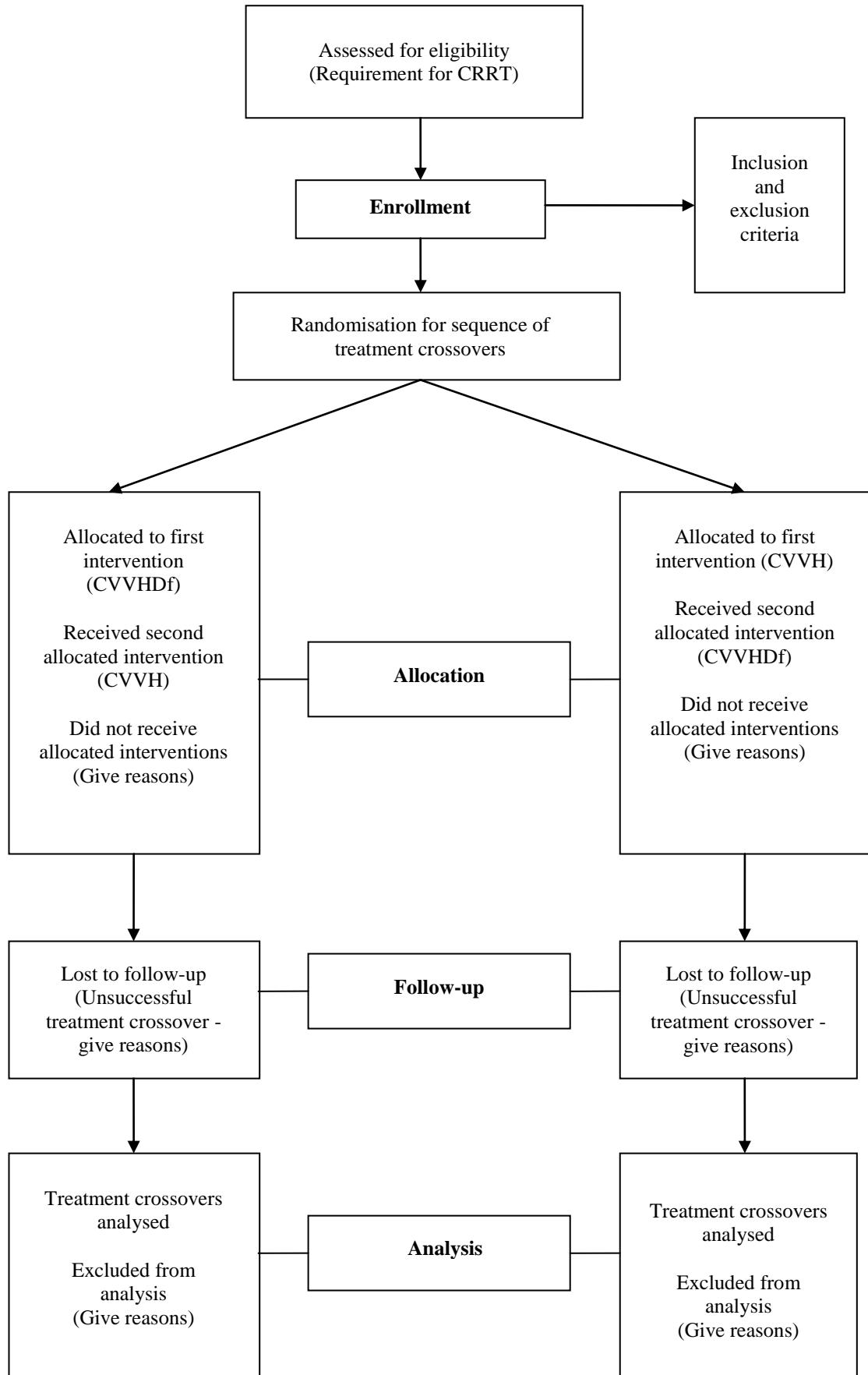

Figure 4.1. Flowchart showing how the research process was followed during the investigation.

Table 4.1
Selection criteria

Inclusion Criteria	Exclusion Criteria
Patients > 18yr	Existing coagulopathy:
Required CRRT to treat:	- aPTT > 80s
- Fluid overload	- INR > 3
- Hyperkalaemia	Thrombocytopenia (platelet count < 50 x 10 ⁹ /L)
- Acidaemia	Haemorrhage within last 24hr
- Ureaemia	
- Other (drug toxicity)	

The severity of illness within the sample of study participants was measured using the APACHE II scoring system. The APACHE II score is calculated from the sum of points assigned to the acute physiology score, age-related score and a chronic health evaluation score with a possible maximum APACHE II score of 71 points (Knaus, Draper, Wagner, & Zimmerman, 1985). The use of the APACHE II scoring system was developed by healthcare providers as a means to predict outcomes based on the severity of illness observed when patients were admitted to ICU (Marik & Varon, 1999). The points allocated using the APACHE II scoring system incorporate variables chosen and weighted according to its impact on patient survival. The 12 physiological variables collected during the first 24hr after admission to ICU reflect the greatest deviation from normal and as such predict a worse outcome for the patient (Knaus, et al., 1985). Included in the acute physiology score are measurements of plasma sodium, potassium and creatinine values to identify whether derangement and loss of urinary output has occurred as a consequence of renal insufficiency. The reliability of the APACHE II score to measure illness severity and accurately predict the survival of patients with AFR has been the subject of investigation following the introduction of the scoring system. A score of more than 40 was found in one study to be a consistent predictor of death when the management of ARF was associated with the use of RRT (Maher et al., 1989).

The APACHE II scoring system can result in errors during the interpretation and allocation of points when lack of agreement on the definition of renal insufficiency

causes inconsistent scoring to describe the physiological abnormality (Goldhill & Sumner, 1998). The limited number of renal parameters included in the instrument also reduces the usefulness of the assessment tool in its ability to estimate the prognosis of patients with ARF. A study by Schaefer and associates (1991) found that on admission to ICU patients who required RRT the median APACHE II score was similar for both non-survivors and survivors (non-survivors median APACHE II score 24 versus survivors median APACHE II score 22). Despite these shortcomings the APACHE II scoring system has been widely adopted by investigators to assess the severity of illness in critically ill patients with ARF (Bagshaw, Laupland, Doig, et al., 2005; Bellomo, et al., 2000; Brivet, et al., 1996; Ronco, et al., 2000).

The sample of patients recruited to participate in the study was drawn from the 4,326 patients admitted to the ICU at Royal Perth Hospital (RPH) between 2004 and 2006. During this period the number of patients diagnosed with ARF was 224 (5.2%). Out of these patients 116 (51.8%) went on to require CRRT (RPH ICU Database). As part of each patient's APACHE II score the study incorporated the ANZICS Clinical Trials Group definition of ARF (Bellomo, et al., 2000):

- A urine output averaging < 0.5 ml per kg per hr over 4hr or longer
- A serum creatinine concentration $> 150\mu\text{mol}$ per L in the absence of premorbid renal dysfunction
- A rise in serum creatinine concentration of $> 80\mu\text{mol}$ per L in less than 24 hr in the absence of creatine kinase > 5000 IU per L or myoglobin in the urine

Setting

The research project was undertaken in the ICU at RPH, Western Australia's largest teaching hospital. The 24 bed intensive care facility is a Level 3 adult ICU and complies with standards set by the Joint Faculty of Intensive Care Medicine of the Royal Australasian College of Physicians and the Australian and New Zealand College of Anaesthetists (2003). The standards define a Level 3 adult ICU as a designated area within the hospital which is capable of providing complex multi-organ life support and has access to a full range of clinical and laboratory services. In accordance with these standards a number of Intensive Care Specialists are employed who supervise Senior Registrars undertaking training in Intensive Care Medicine supported by Junior

Registrars and Residents of whom many are on rotation from other medical disciplines. The standards also require only Registered Nurses to be responsible for patient care, and over 50% to have a post registration qualification in intensive care nursing.

The ICU at RPH serves as a State referral centre for the management of the critically ill patient with approximately 1,600 patients referred to the ICU each year offering sophisticated high technology medical care to treat a wide range of disease processes electively or as the result of a medical emergency. The 'General ICU' admits a variety of medical and emergency surgical patients. The type of patients which are managed include patients with community acquired pneumonia who develop respiratory failure and require mechanical assist ventilation, or patients who are haemodynamically unstable due to severe infection and at risk of multi-organ failure, or patients who have overdosed on toxic substances which may have the potential to cause metabolic abnormalities and respiratory distress. The 'Surgical ICU' is allocated for patients who have sustained injuries following major trauma or who have undergone cardiac surgery and other surgical procedures either electively or when performed urgently. The type of patients admitted include those who require surgery for severe closed head injuries and fixation of muscular skeletal fractures and/or repair of vascular damage as a result of major trauma, whilst cardiothoracic surgery is undertaken on patients who require coronary artery bypass grafting or heart valve repair or replacement. The ICU also accepts patients who require heart and lung transplantation, the management of patients who have been referred for the insertion of artificial heart technology, and patients who require temporary life support using Extracorporeal Membrane Oxygenation technology. The workload can change rapidly due to the nature and number of patients who are admitted to the ICU exposing the critical care nurse to a dynamic working environment.

The use of CVVHDF at RPH is the preferred method of RRT by consultant medical staff for the management of critically ill patients who have developed severe ARF and not responded to supportive measures in response to a decline in renal function. Medical and nursing experience was first gained in the ICU using CAVHDF and CVVHDF. As staff became more familiar in using these techniques the importance of maintaining circuit life to maximise the treatment's effectiveness was soon realised and studies were subsequently undertaken in the unit to investigate aspects of both techniques which could impact on circuit life (Leslie, et al., 1996; Leslie & Thomas, 1991). Although these studies used technologies which are now redundant and practices

no longer carried out, the information previously collected provide an historical control on which to base future research.

Equipment



Figure 4.2. The Hygieia ‘Plus’ CRRT machine (KIMAL plc, Middlesex, England).

The Hygieia ‘Plus’ CRRT machine (KIMAL plc, Middlesex, England) was used throughout the duration of the study after the appliance had been earlier introduced into clinical practice at the study site in 2002. Unlike the ‘make-shift’ devices previously used, the custom-made CRRT machine shown in Figure 4.2 integrated circuit pressure monitoring with the regulation of fluid exchanges. A display screen allowed the operator to select convection-based (CVVH) and diffusion-based (CVVHdf) techniques with step-by-step instructions for the operator on how to setup the machine, prime and connect the circuit to the patient. The CRRT machine incorporated four roller pumps which regulated blood flow and using volumetric infra-red technology, controlled the rate of dialysate and fluid replacement delivered and the rate of ultrafiltrate produced. On commencement of treatment the operator was able to use the touch-screen controls to make adjustments in the rate of blood flow and on the amount of fluid to be

exchanged. Circuit pressures also displayed on the screen allowed the operator to monitor the development of flow obstruction caused for example by blood clots and if necessary ‘troubleshoot’ problems in response to interruptions in blood flow. Negative outflow (arterial) and positive return (venous) pressure alarms were integrated with an air detector alarm on the venous blood line and a blood leak sensor in case of membrane rupture on the ultrafiltrate line (KIMALplc, 1999).

The extracorporeal circuit consisted of separate outflow and inflow blood lines made from polyvinyl chloride (PVC) tubing and individual fluid lines of the same material to deliver replacement fluid and dialysate solutions (Polaschegg, 1995). Similar to most circuitry designed where blood is pump-driven, the arterial blood line included the segment required for insertion around the roller pump and the venous blood line incorporated the air trap chamber. The components required to perform both treatment modalities were the same except for minor variations associated with differences between the two techniques. The CVVH circuit did not require the dialysate line and the ‘heater bag’ (as part of the Hygieia ‘Plus’ CRRT machine design feature for the warming of fluid) was located with the fluid replacement line. In contrast the CVVHDf circuit used the dialysate line to incorporate the heater bag instead of the attachment being connected to the fluid replacement line. The differences in the layout between the CVVH circuit and the CVVHDf circuit are shown in Figure 4.3. The same Nephral 300ST haemofilter (AN69 membrane) made of acrylonitrile and sodium methallyl sulfonate copolymer was used for both treatment modes (Hospal, Lyon, France). The membrane comprised of fibres which had been specially treated with heparin to improve biocompatibility and the length and number of fibres gave a total wet surface area of 1.3m². The operator of the CRRT machine was required to assemble and put the various components of the circuit together before a priming solution could be administered. A stockpile of circuit components were packaged and stored at the study site in marked containers according to the technique required.

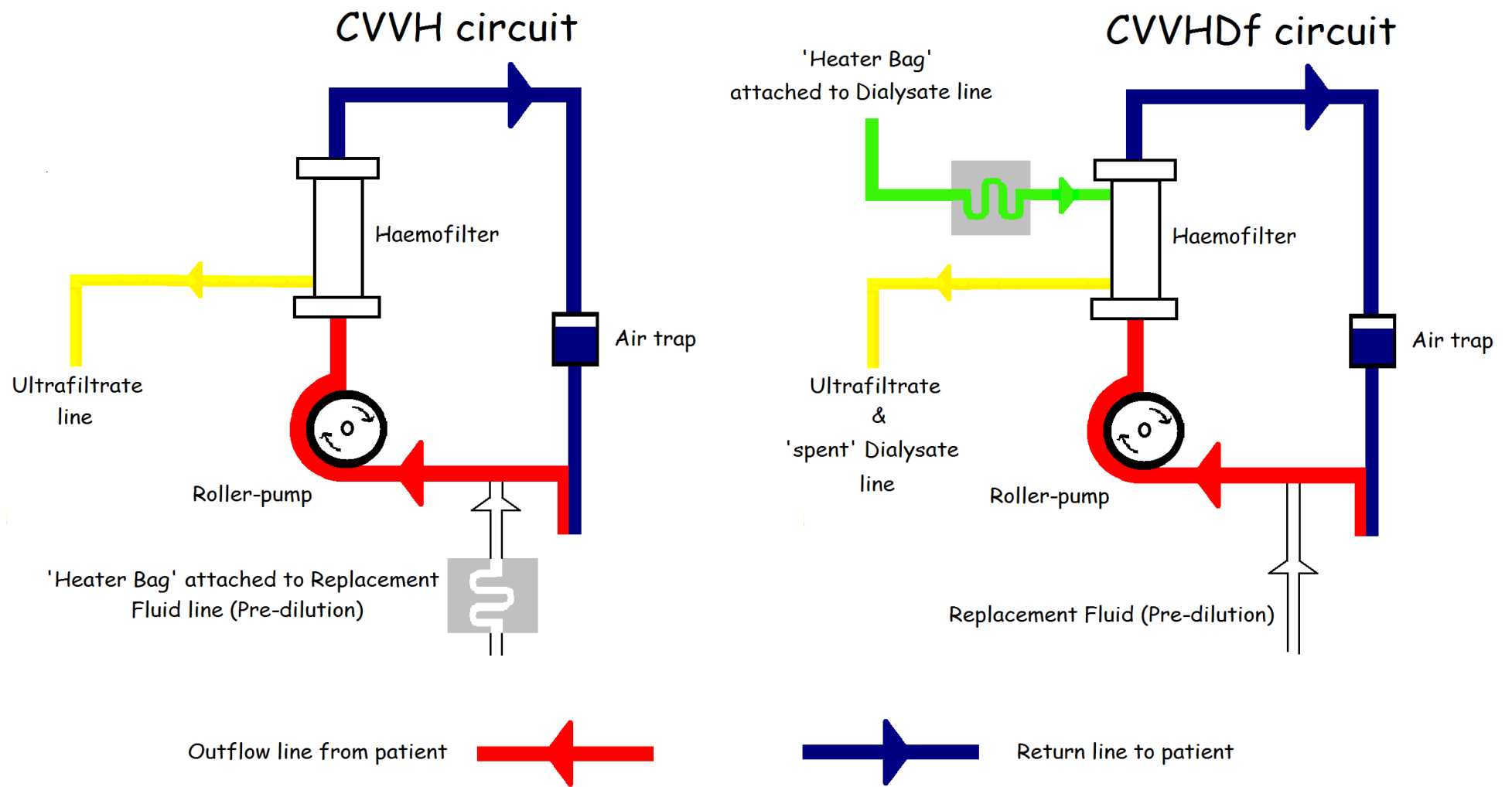

Figure 4.3. An illustration of the differences in the layout between CVVH and CVVHDF circuit configurations.

The selection of a double lumen venous catheter was based on personal preference and clinical judgement of the Medical Officer on the choice of catheter length and size of the inner diameter required. The decision was also influenced by the availability of the vascular device commonly used at the study site with an historical supply and preference for the GamCatheter™ (Joka Kathetertechnik, Hechingen, Germany). The device had an 11 French (Fr.) gauge inner diameter and a catheter length of 150mm, 200mm or 250mm according to the choice of either internal jugular, subclavian or femoral insertion site. The other vascular access devices used during the investigation included the Arrow-Howes™ (Teleflex Medical, Durham, USA) double lumen venous catheter which had a similar inner diameter gauge size, to the use of the alternative Cook™ (Cook Critical Care, Bloomington, USA) double lumen catheter which had a larger 12 Fr. gauge inner diameter, or the Niagara™ (Bard Access Systems, Salt Lake City, USA) having the largest gauge of 13.5 Fr. inner diameter catheter measurement.

Design

The investigation of circuit life between CVVH and CVVHDf was a study experimental design. The term ‘experimental design’ refers to a plan for assigning patients in a clinical study to experimental conditions followed by a plan to undertake a statistical analysis of the results (Kirk, 1995). The simplest form of a clinical experiment is the parallel groups design. Suitable patients who have consented to participate in the study are randomised to receive one and only one of two or more treatments under investigation (Fleiss, 1986). Analysis of the specific intervention involves the comparison of its effect on patients who received the treatment against those patients who were not exposed to the therapy. A potential disadvantage of the parallel technique lies in the design which takes no account of differences in patient characteristics when measuring the response to the administration of a specific treatment. The ability to control for differences in the severity of critical illness and the impact of variations in pathology amongst patients participating in the study was an important consideration when planning the design of a study investigating circuit life using different CRRT modes.

Cross-over study design

Similar to other interventions employed in the management of the critically ill patient the underlying cause of disease and illness severity can have an overwhelming

effect when evaluating the response to a specific treatment strategy. For example, differences in the coagulation profile of a patient placed on CRRT who has liver failure may influence the longevity of circuit life or the amount of anticoagulant required to maintain the circuit when compared with patients who receive CRRT but have no history of liver failure and are observed to have normally coagulatory activity. Sequential experimentation is a method of analysis which allows the response of two or more treatments to be compared when each treatment is administered to the same patient. This type of study is classified as a cross-over experimental design study with the objective of observing differences between each individual treatment separately. The sequence of treatments is not as important as the effect which is observed when the same patient is exposed to all of the treatments under investigation. The simplest cross-over method is the two-period two-treatment or 2x2 study design (B. Jones & Kenward, 1989). This method involves the delivery of two different treatments which can be conveniently described as the administration of treatment A followed by treatment B to one group of subjects as opposed to the other half who instead receive treatment B followed by treatment A. The main feature of the cross-over study design which distinguishes it from other experimental study designs is that measurements are therefore taken on different treatments using the same subject (B. Jones & Kenward, 1989). This provides disadvantages as well as advantages in the way comparisons are made when evaluating different responses to alternative treatment options.

The cross-over component featured in the study design offers the advantage of making a direct comparison of multiple treatments, whilst reducing the influence an underlying disease may have on the measurements observed during the assessment of each treatment (B. Jones & Kenward, 1989). The impact septic mediators may have on the coagulation profile of patients with severe sepsis compared with their absence and a near normal coagulation profile in patients who have undergone cardiothoracic surgery is an example of how the primary cause of ARF can influence circuit life when both patients are exposed to the same treatment mode (Schetz, 1998). The features of a disease process belonging to the same patient can disproportionately influence the responses observed in circuit life which are observed when comparisons are made among the other patients participating in the study. The variability observed when measurements are recorded from different patients in response to a specific treatment is often greater than the variability of treatment responses observed when repeated measurements are taken from the same patient (B. Jones & Kenward, 1989).

Another feature of the cross-over study design involves the order how each patient is exposed to the treatments under investigation with the potential for large variations to occur in repeated measurements due to the variability in severity of the disease process. The natural progression in the severity of disease may cause changes in the longevity of circuit life which are observed when over the duration of the different treatment modes the condition of the patient improves and adequate renal function is restored. As a consequence of renal insufficiency the accumulation of uremic toxins may contribute to a reduction in platelet activity and increase the likelihood of coagulation disorders (Schetz, 1998). On commencement of treatment the acquired platelet dysfunction is gradually resolved under the influence of CRRT and on the resolution of renal insufficiency. The improvement in renal function coincides with the restoration of normal coagulation activity but the affect is not equally distributed and the influence this can have on circuit life may vary according to when each treatment mode was started.

A disadvantage of using a cross-over design study is the potential for a carry-over effect (B. Jones & Kenward, 1989). This occurs when the effects produced by one treatment are transferred and influence the response observed when the other treatment is administered. The carry-over effect is virtually overcome when three or more treatments are measured, but can be more of a problem when the simpler 2x2 crossover study design is used. On occasions where the use of a 2x2 crossover study design is unavoidable the chances of a carry-over effect are minimised when a 'wash-out' period allows a pause to occur between each treatment. The use of a 2x2 crossover study design is considered appropriate when the carry-over effect is judged to be small (B. Jones & Kenward, 1989).

The impact of CVVH versus CVVHdf on circuit life was investigated using a 2x2 crossover study design which allowed for individual patient characteristics to be limited when evaluating the effect of treatment mode on circuit life. Each time a treatment was completed and the disposable circuit discarded many of the effects of the mode were isolated to the circuit and not carried-over to the alternative treatment. Other than the time normally required to take down and prepare a new circuit a specific 'wash-out' period was not included in the design of the study. A limited carry-over effect was nevertheless possible with commencement of the alternative treatment influenced by differences in the progression of the disease process following the instigation of the previous mode and in the earlier administration of exogenous heparin.

The period of time required to achieve a successful crossover between CVVH and CVVHDf had the potential to take several days to complete. During the course of both treatment modes life-saving interventions including the commencement of CRRT would result in the likelihood of an improvement in the patient's condition. The correction of abnormalities is subsequently transferred when resolution of the disease process coincides with a cross-over to the alternative treatment mode. A patient with sepsis who develops ARF is an example of how the disease process can influence circuit life during CRRT when the duration taken by each mode to achieve a successful crossover occurs over several days. The previous treatment mode may commence when natural anticoagulants in the body are reduced due to the affects of sepsis on the coagulation system with a hypercoagulatory state prevailing in the extracorporeal blood (Balk, 2000). As the coagulation system returns to normal in response to the resolution of infection and dissipation of the inflammatory response, the alternative mode has the potential for extended circuit life due to decreased procoagulatory activity in the extracorporeal blood. The effects of sepsis on the coagulation system can also be diminished by the removal of septic mediators during CRRT and influence circuit life when commencement of the alternative treatment mode is protracted and modulation of the inflammatory response has occurred with the mode first assigned to the patient (Subramanian & Kellum, 2000).

The use of heparin to anticoagulate blood along the circuit has the potential to remain active in the body after the completion of the initial allocated mode. The effects of the anticoagulant agent are capable of being transferred when cross-over to the alternative treatment occurs, and exposes the circuit to the same 'heparinised' blood which was circulated through the original circuit associated with the previous mode. The residual influence of heparin impacting upon circuit life between treatment modes is influenced by the short half-life of heparin and the time required to set-up a new circuit. The anticoagulant effect of unfractionated heparin on antithrombin III when delivered intravenously has a short half-life of approximately one hour (Baglin, Barrowcliffe, Cohen, & Greaves, 2006). The preparation of a new circuit required approximately 30 minutes before the circuit was able to be connected to the patient. The possibility of a residual influence from the previous administration of heparin in the blocking of thrombin and factor Xa was subsequently minimised, since the half-life of the anticoagulant agent would be almost reached when the new circuit using the alternative treatment mode was made ready to use.

Allocation of patients to treatments

The control of bias in favour of a particular treatment is important to ensure the integrity of the study is maintained. The process of randomisation is used in comparative studies to avoid conscious or unconscious bias in the allocation of participants to a specific treatment (Chow & Liu, 2004). This was an important consideration for this study when comparing circuit life since it was not possible to 'blind' the investigation between the two treatment modalities. The nature of the intervention could not disguise the technique from the bedside nurse who was required to operate the CRRT machine. The set-up of the machine easily identified the technique in use with the inclusion of dialysate as an indicator of CVVHdf, whilst CVVH was recognised by the absence of dialysate. Also, the bedside nurse was required to make decisions in regards to solute clearance and fluid removal based on which technique was employed. The potential to extend circuit life using one of the techniques under investigation introduced the possibility for bias to occur in the sequence of treatments allocated to the patient. An attempt could be made by the bedside nurse to manipulate the mode of treatment each patient received if a more favourable circuit life was associated with a particular technique. Any intervention which was observed to increase the duration of treatment and reduce the workload associated with the set-up of a new circuit would be a strong motivating factor in the choice of treatment selected.

Randomisation

The process of randomisation can be used to avoid subjective assignment of treatments to patients who participate in clinical studies (Chow & Liu, 2004). Patients enrolled in the study represent a sample of the population under investigation and statistical inference is able to be drawn from the probability of distribution in the target patient population. The probability distribution assumption and reliability of the statistical analysis depend on the randomisation model used. Although treatment comparisons are performed by randomisation the study site and patient selection were not random.

The methods used to randomise subjects to a specific treatment can be classified according to three randomisation techniques. They include the assignment of subjects either through complete randomisation, permuted-block randomisation or adaptive randomisation (Chow & Liu, 2004). The randomisation process chosen to investigate

the impact of higher volume predilution CVVH versus CVVHDF on circuit life employed the method of complete randomisation.

Complete randomisation is the simplest method of selecting patients to randomly receive a specific treatment (Chow & Liu, 2004). The method places no restrictions on the sequence of randomisation provided that the number of subjects recruited achieves the desired statistical power and the required distribution of patient allocation is obtained between treatments. The application of complete randomisation in the design of this study created a 50% chance for patients participating in the study to either receive CVVH followed by CVVHDF or to receive instead CVVHDF followed by CVVH. The method chosen made sure all of the patients enrolled in the study were independently assigned to receive each treatment in a randomised order. Since complete randomisation placed no restrictions on the sequence of treatment allocation the study was exposed to unequal sample group distribution in regards to the starting treatment, with the potential risk of one type of mode being selected more frequently than the other mode under investigation. The potential for unequal sample sizes is increased among treatment groups when the total sample size is small (Chow & Liu, 2004).

A set of randomised numbers can be obtained either by using a table of random numbers in a statistical textbook or by accessing a statistical computing software package (Beller, Gebski, & Keech, 2002). Study participants received both treatment modalities in a random order using a computer generated set of randomised numbers. The set of randomised numbers was generated using the 'Research Randomizer' computer program retrieved from the website <http://www.randomizer.org>. The Research Randomizer uses the 'Math.random' method within the JavaScript programming language to generate a set of random numbers. Similar to other computer-based programs the numbers are obtained by a complex algorithm originating from the computer's clock that gives the appearance of randomness. Although the computer cannot generate a set of 'true' random numbers the use of a 'pseudo-random number generator' is considered to be appropriate for use in the majority of clinical studies undertaken.

The Research Randomizer was accessed to perform the process of complete randomisation using a list of parameters chosen from a menu of choices which determined the output produced. Only one set of random numbers was required. The set of numbers consisted of 150 values considered sufficient to enable each patient

recruited a randomised treatment allocation. The numbers ‘one’ and ‘two’ were used to represent CVVH and CVVHdf. Each number was consequently not required to remain unique or to be sorted in a particular order. The set of randomised numbers was presented using the default setting of the computer program with the layout of values not indicated by placement markers. The output of random numbers produced by the Research Randomizer is contained in the Appendix B.

Process

Patients admitted to ICU who required CRRT were considered as potential candidates for this study. A review of the patient’s medical history determined eligibility in meeting selection criteria. The design of the study did not delay CRRT and when ordered by the intensive care specialist on duty, the normally preferred treatment mode of CVVHdf commenced. Patients who met the inclusion criteria as shown in Table 4.1 were either approached to participate in the study or the next-of-kin when the patient was incapable of providing consent.

Once consent was obtained, patients were randomised and assigned to receive either CVVH or CVVHdf at the start of treatment or after the normally preferred treatment mode of CVVHdf was scheduled to be taken down. A series of sealed envelopes had a number written on the front of each envelope which corresponded with the patient’s enrolment number. Inside each envelope was a card that gave instructions on which treatment the patient was assigned to receive. The envelopes were placed in a tray marked ‘un-used envelopes’. This was stored at a central location within the ICU. Once the envelope had been opened and instructions given on which treatment mode the patient had been randomised to receive, a patient identification label was attached to the card and then inserted back into the envelope and placed into a second tray marked ‘used envelopes’. The attachment of patient labels to each card when the envelope had been opened ensured a record of treatment allocation was able to be maintained.

Instructions written on the card gave directions as to the location of a specially marked container specifically set aside for use at the study site. The container held study circuits, packaged and labelled according to treatment mode, which were only to be used for patients participating in the study rather than using circuits earmarked for general use. The purpose behind the creation of packaged circuits was to ensure the circuit correctly matched the treatment mode allocated to the patient and to avoid the potential for confusion during the setup of the circuit. This assisted the operator to have

the correct circuit components that were required for CVVH as opposed to CVVHDF with the supply of packaged circuits maintained throughout the study period. The use of packaged study circuits also allowed a record to be maintained of the total number of circuits used during the study according to the allocated treatment mode.

Once the Patient had been randomly selected to receive either CVVH or CVVHDF thereafter, the patient alternated sequentially between these two techniques. In circumstances where the circuit had run its natural course on both occasions, only one crossover between the two treatment modalities was required. If the patient continued to require CRRT the normally preferred treatment modality of CVVHDF was then used.

Determinants of a 'Natural' Circuit Life

The measurement of circuit life using CVVH and CVVHDF was based on when the patient was first connected to the circuit until disconnection occurred following a decision to end treatment. A 'natural' circuit life was defined as the spontaneous appearance of circuit failure caused by the accumulation of blood clots along different sections of the circuit. The decision to take down the circuit as a result of clotting was based on visual inspection and increases in circuit pressures displayed on the Hygieia 'Plus' monitoring screen. Observations made by the bedside nurse showing the appearance of blood clots within the haemofilter and venous bubble were checked against evidence of higher resistance to blood flow through the circuit by a gradual increase of pressure across the membrane (TMP > 200mmHg) and along the return line (P-venous > 150mmHg). The lifespan of a circuit was not considered to have been reached naturally when reasons other than clotting caused the circuit to be taken down electively:

- Problems with vascular access
- Haemodynamic instability
- Procedures to be performed outside of ICU
- When there was a return of urinary output
- If death of the patient had occurred.

Crossover Procedure

The crossover procedure between CVVH and CVVHDf only applied when the circuit for both treatment modes had run its natural course and was taken down due to clotting. An illustration of a successful treatment crossover is shown in Figure 4.3. If on the other hand the CVVH or CVVHDf circuit was taken down due to causes apart from clotting a successful crossover was not deemed to have occurred between the two modes of treatment.

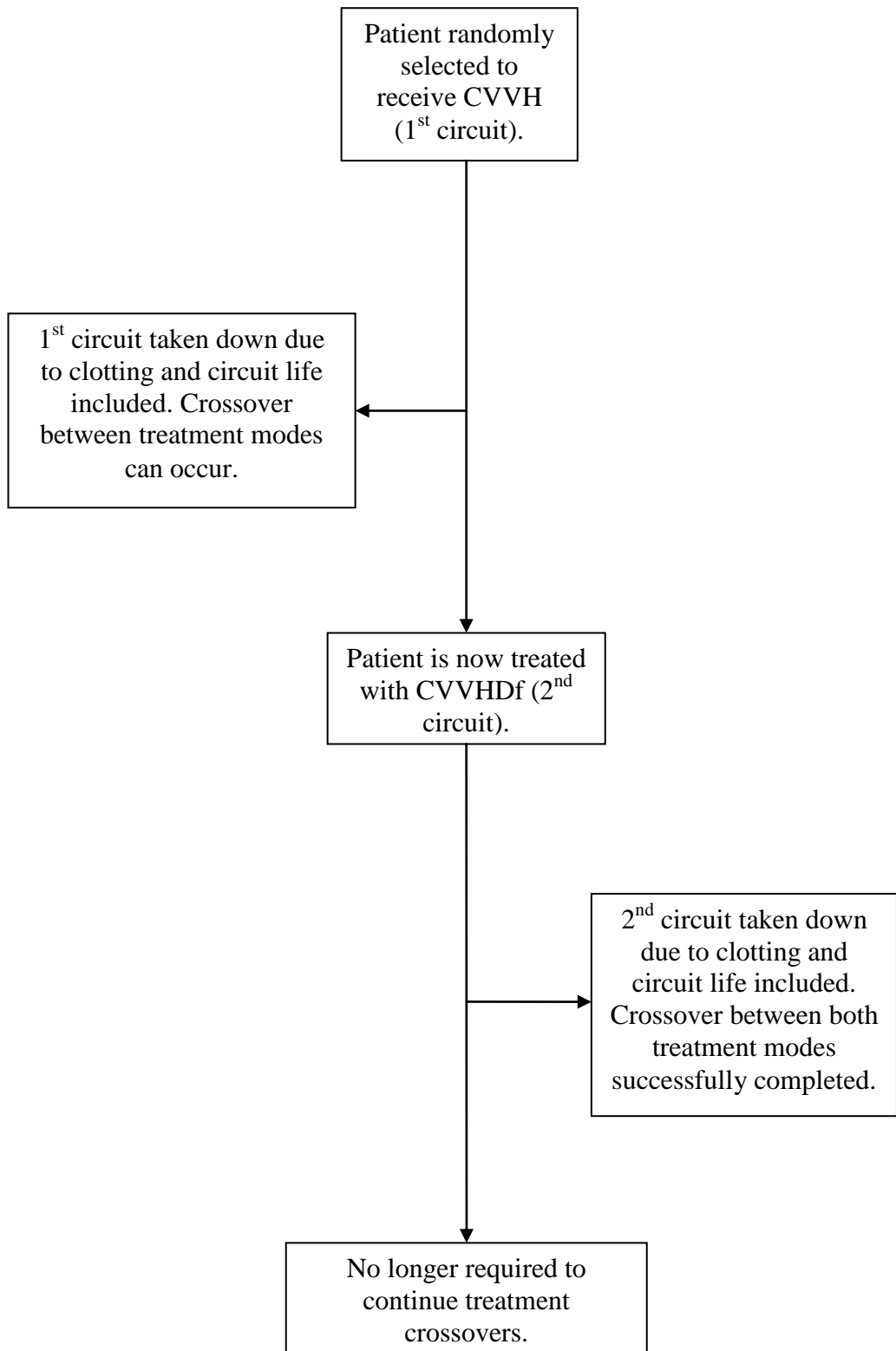

Figure 4.4. A successful crossover between CVVH and CVVHDF.

A number of clinical scenarios were identified as possible situations which in the event they occurred would interrupt the crossover procedure. As shown in Figure 4.4

should the patient be initially randomised to receive CVVHDF, circuit life is disqualified and crossover disallowed, when in the case of this scenario the patient required surgery and the first circuit was taken down electively in preparation for transport to the operating theatre. Crossover to CVVH could not take place since the natural life of the CVVHDF circuit had not been reached. Once the patient had returned from the operating theatre continuation of CVVHDF was required until a circuit using this treatment mode was taken down having reached its natural life. The same scenario could also be applied to patients who instead of surgery required radiological diagnostic procedures to be performed outside of the ICU.

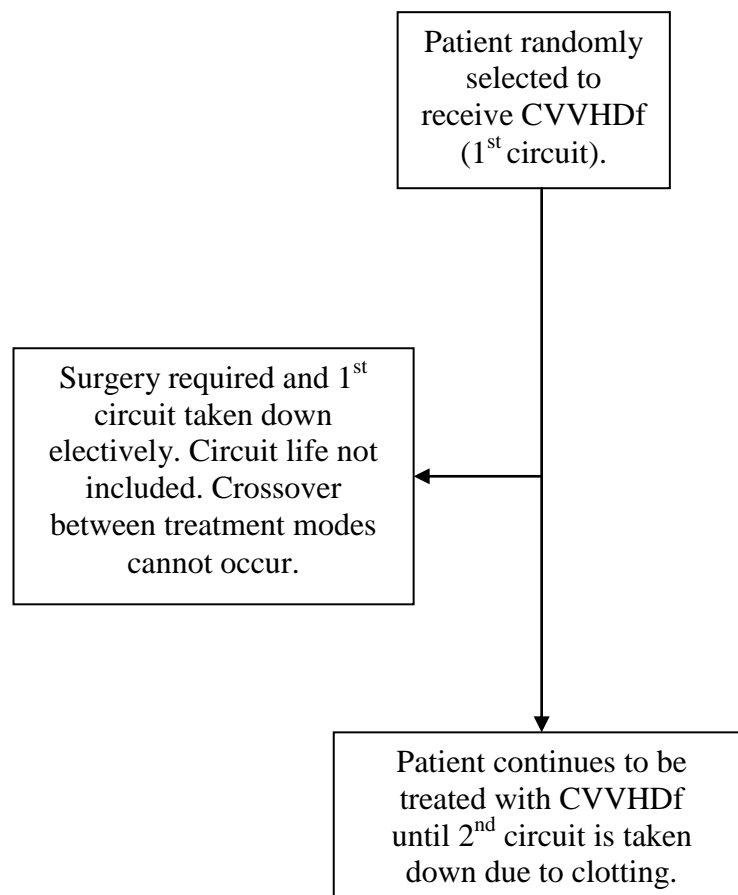

Figure 4.5. An unsuccessful crossover.

The occurrence of problems with the insertion site or the catheter device is another example of a clinical scenario as shown in Figure 4.5 which could interrupt the crossover procedure. Blood flow that is failing with frequent pump stoppages due to inadequate vascular access would predispose to premature clotting and not represent a true reflection of circuit life. In response to an increasing number of blood flow interruptions, and a requirement to operate at a faster blood flow rate, could lead to a

medical decision to replace the catheter device at the same or different insertion site and the judgement by the bedside nurse to prematurely terminate the circuit. The attempt to crossover from CVVH to CVVHDf would be invalid in this scenario since the first circuit was not taken down following a natural circuit life. The crossover between each treatment mode would also not compare circuit life with the same catheter device and use a potentially different insertion site.

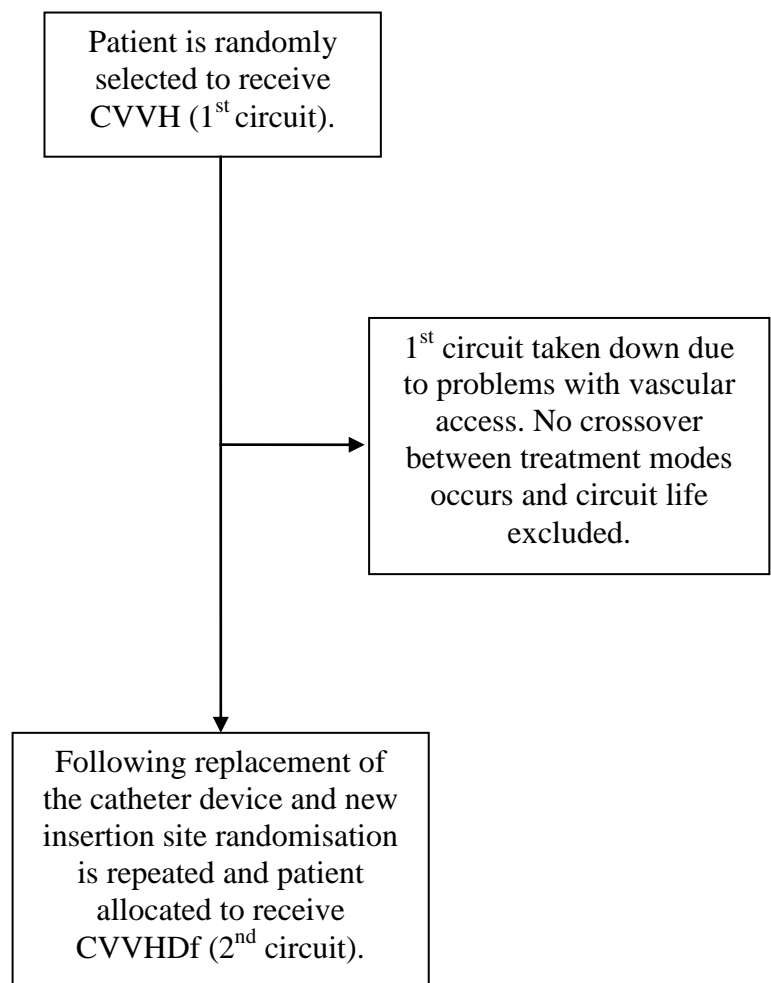

Figure 4.6. Crossover interrupted by vascular access problems.

The administration of 0.9% normal saline flushes through the circuit is another example of a scenario which jeopardised the crossover procedure. The exposure of circuits to one or more bolus doses of 0.9% normal saline introduced an additional variable in the assessment of circuit life between the two treatment modes under investigation. At the time of the study there was no evidence to suggest the administration of 0.9% normal saline flushes would influence the lifespan of the circuit (Prasad, et al., 2000). Although when delivered into the circuit the infusion of 0.9%

normal saline can serve as a useful strategy for the visual inspection of the haemofilter and venous bubble trap to detect signs of clotting (Davies & Leslie, 2006). Unless the procedure was able to be regulated and the same intervention given to both treatment modalities the administration of 0.9% normal saline was not considered of sufficient value to be included as a variable and the practice discouraged whilst patients participated in the study. Only after the study was completed has evidenced been published to suggest in patients who are coagulopathic the use of 0.9% normal saline can promote circuit life when the use of anticoagulants is contraindicated (Nagarik, et al., 2010).

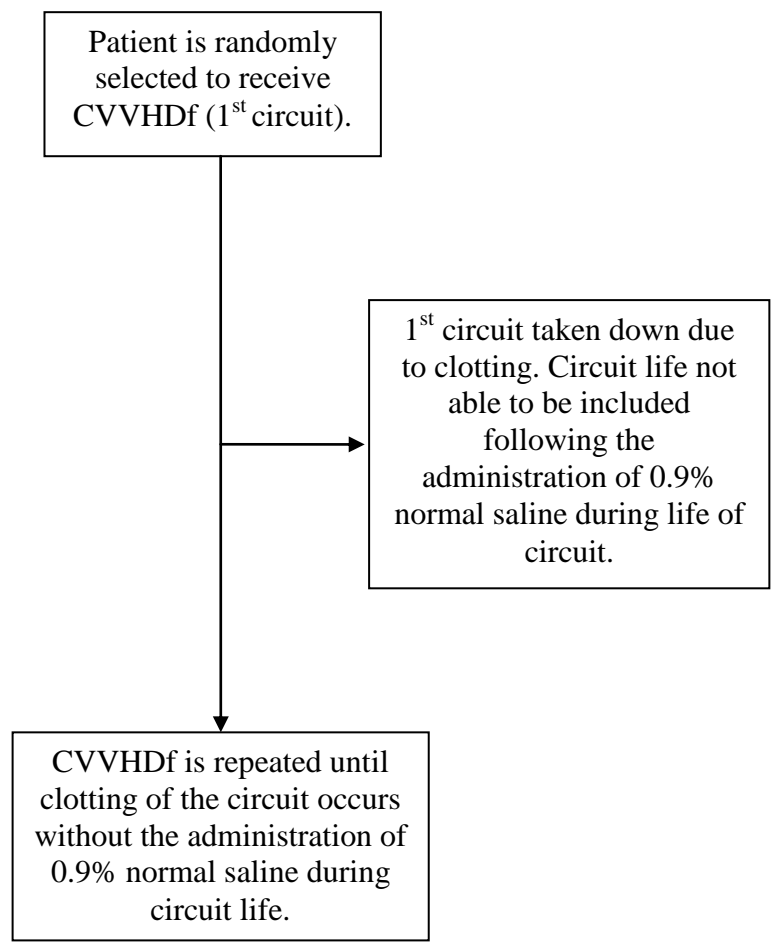

Figure 4.7. Crossover interrupted by the administration of 0.9% normal saline.

The scenario shown in Figure 4.6 illustrates a situation where flushing of the circuit with 0.9% normal saline has occurred after the patient was randomised to receive CVVHdf. Despite the circuit reaching a natural lifespan and taken down due to clotting the circuit life measured is ineligible. The administration of a 0.9% normal saline flush prevented a successful crossover to the alternative treatment mode of CVVH. The same treatment mode of CVVHdf is instead repeated and continued until the circuit using

this technique is taken down due to clotting without the use of 0.9% normal saline flushes. The recirculation of 0.9% normal saline through the circuit to allow disconnection from the CRRT machine and transportation of the patient outside of the unit for diagnostic procedures also produced a situation where the crossover process to the alternative technique would be interrupted. In order to achieve a satisfactory treatment crossover the previous mode is repeated again until it is taken down due to clotting without the recirculation of 0.9% normal saline having occurred during the lifespan of the circuit.

The pre-dilution volume for CVVHdf was not allowed to change unless deterioration in the patient's condition required adjustments to be made to the haemofiltration rate of flow. In the event changes were required alterations of between 500ml to 2L could nevertheless be made to the dialysate rate of flow which would not invalidate the circuit life measured. On the other hand the effect of changes in pre-dilution volume above 600mL would introduce an extra variable in the measurement of circuit life. In this situation a successful crossover to CVVH was prevented. The scenario as shown in Figure 4.7 involves the alteration of the haemofiltrate component of CVVHdf. Despite a favourable crossover to CVVH following clotting of the first circuit the crossover was subsequently violated. During the life of the second circuit using CVVHdf the pre-dilution volume (normally 'fixed' at 600mL per hr) was increased to 1200mL per hr. The increase in pre-dilution volume during CVVHdf causes the affect of haemodilution in the circuit to change. Unless the same pre-dilution volume is maintained comparisons of circuit life with CVVH are confounded by variability in the haemofiltrate component of CVVHdf.

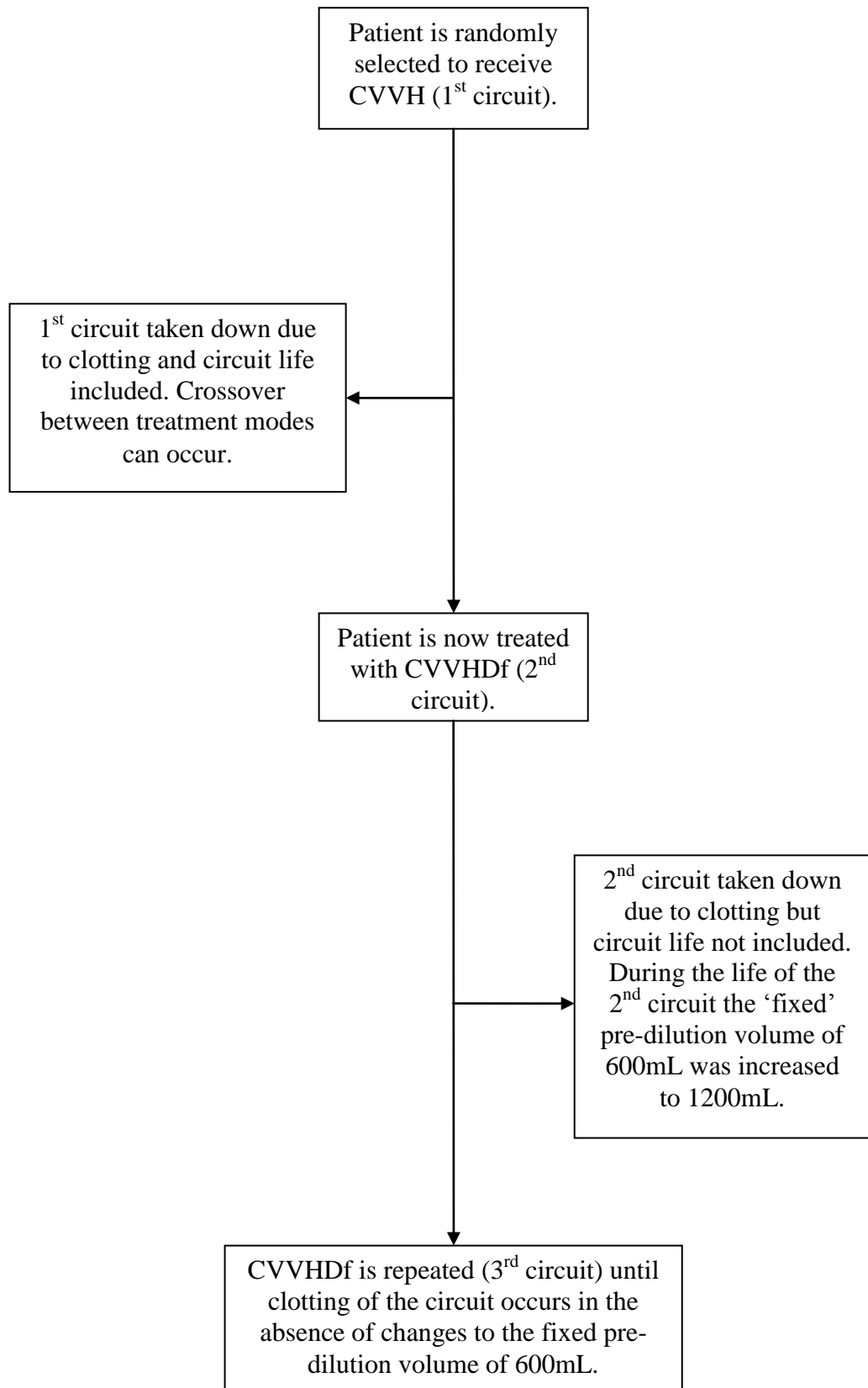

Figure 4.8. Crossover interrupted after alterations were made to pre-dilution volume during CVVHDF.

The difficulty associated with ensuring a successful crossover occurred between CVVH and CVVHDF is again shown in Figure 4.8 when crossover was prevented by the return of urinary output, or in Figure 4.9 after the patient had died before exposure to the alternative technique. A set of instructions on what constituted a successful crossover was made available at the bedside to assist the nurse to determine whether a successful crossover had been achieved. The ICU observation chart was also examined and comments as to reasons why each circuit was taken down reviewed to determine whether study protocols regarding crossover procedures had been followed correctly.

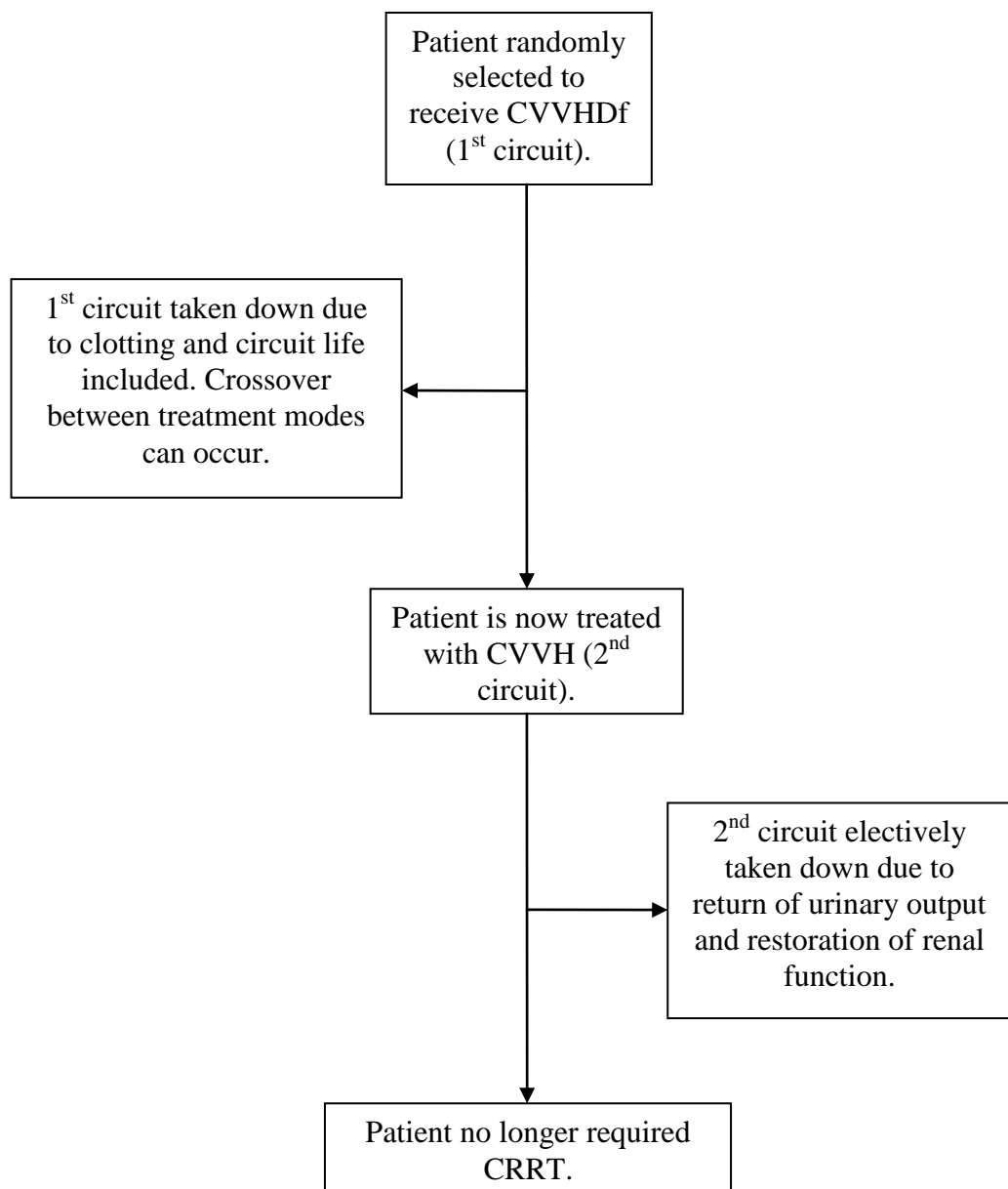

Figure 4.9. Crossover prevented due to return of urinary output and restoration of renal function.

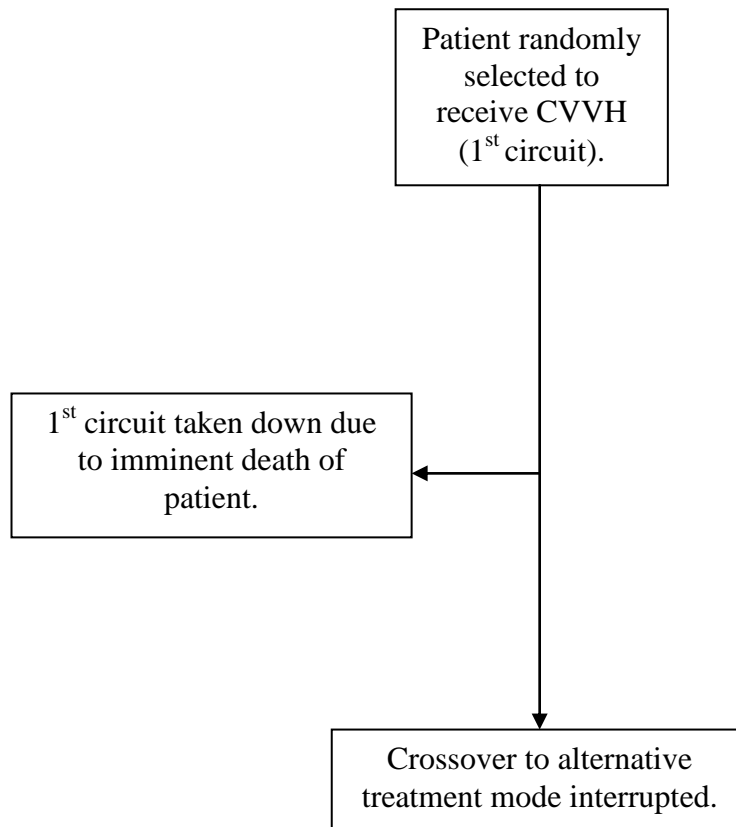

Figure 4.10. Crossover prevented due to death of patient.

Standardisation of Variables

A number of measures were taken to standardise the approach between CVVH and CVVHDf so that differences in circuit life were based on the variable of interest (pre-dilution volume) and not confounded by other factors identified in the conceptual framework.

Technique

An ultrafiltrate dose of 35ml per kg per hr delivered pre-haemofilter was used for CVVH based on evidence of improved patient survival when compared with the post-haemofilter conventional dosage of 25ml per kg per hr (Ronco, et al., 2000). A record of the patient's body weight was made for the purposes of determining the volume of replacement fluid required when the patient was assigned to CVVH. In the majority of cases the patient's weight was routinely recorded within 48 hr of admission into ICU and often required using a hoist capable of lifting the patient and recording body weight measurements in Kilograms. In accordance with established ICU

guidelines (at the time of the study) a fixed pre-dilution volume of 600ml per hr replacement fluid was used for CVVHDF with a dialysate dose of between 500ml to 2L. Dialysate and replacement lactate-based solutions were the same for both treatment modes (Haemofiltration Replacement Fluid, Baxter Health Care, Sydney, Australia). A lactate-free bicarbonate-buffered solution was used for severely acidotic patients (Hemosol BO, Gambro, Sydney, Australia). Blood flow was set and maintained at 200ml per min. Routine blood samples were taken in the morning from arterial blood. A record of laboratory measurements monitoring participants' aPTT, INR, platelet count, haematocrit, urea and creatinine plasma serum levels was kept.

Venous Access Catheter and Vascular Insertion Site

Vascular access was achieved using non-cuffed, non-tunnelled, dual-lumen catheters to access blood from either the subclavian, internal jugular or femoral central veins. Comparisons of circuit life between CVVH and CVVHDF were made using the same venous access catheter and vascular insertion site. If at any stage the venous access catheter or vascular insertion site changed the process of treatment randomisation was repeated. This was undertaken to minimise the potential for variability in blood flow between treatment modes impacting upon circuit life due to the use of different venous catheters and alternative insertion sites.

Anticoagulation

A standard heparin based anticoagulation protocol was employed for both CVVH and CVVHDF. Each circuit was primed with 1L of 0.9% normal saline followed by a heparin rinse at a concentration of 5,000IU in 1L of 0.9% normal saline. Based on patient weight and pre-existing aPTT a continuous heparin infusion of 10,000IU diluted in 50ml of 5% dextrose using a separate syringe driver was delivered pre-haemofilter and adjusted between 200 and 800IU per hr to maintain a patient aPTT of 40 to 55s. A record was made of the amount of heparin delivered during the life of each circuit.

Training and Supervision

At the study site CVVHDF is routinely used in the management of critically ill patients with severe ARF. Whilst the majority of nursing staff were familiar with the set-up and operational characteristics of CVVHDF there was limited experience in using CVVH. It was necessary to provide training and supervision prior to the commencement of the study for all clinical staff, both nursing and medical, and throughout the

continuation of the project to account for new employees or as a refresher course to existing staff members.

The structure of the education programme consisted of several different teaching styles designed to inform the nurse and Medical Officer about the research project. Specific details were given on the requirements of the study and calculation of the treatment dose for CVVH using 35ml per kg per hr prescription order. A variety of different teaching styles recommended by Baldwin (1997) to train staff in the use of CRRT were used. These included lecture presentations, practical demonstration of equipment and instruction at the bedside.

A month before the commencement of the study two half-hour lecture presentations were conducted per week in the ICU seminar room. The frequency of lecture presentations was considered appropriate in an attempt to maximise exposure of the presentation to approximately 130 nursing and 40 medical personnel who were employed as shift-workers on a full-time or part-time basis. Several members of the ICU clinical staff were encouraged to attend in recognition of the important role they played in the department. Those targeted included medical Consultants and Senior Registrars responsible for the management of patients with ARF and nursing staff who had clinical expertise in the care of patients requiring CRRT such as Clinical Nurse Specialists, Staff Development Nurses and Clinical Nurses. The number who attended each lecture presentation was measured against a register of clinical staff likely to be exposed to patients receiving CRRT. In determining the commencement date of the study a target of 60% or more was considered as appropriate coverage for all staff in the department assigned to patient care.

In addition to the lecture presentations several practical workshops were organised to provide 'hands on' experience with using the technique of CVVH. Attention was drawn to the main difference in circuit layout being the absence of the dialysate fluid line and the heater bag located on the fluid replacement line. Operational comparisons with CVVHdf were also highlighted during the workshop using a practice CVVH circuit attached to the Hygieia 'Plus'TM CRRT machine. The audience was encouraged to adjust treatment settings and enter the correct dose for CVVH on the Hygieia 'Plus'TM CRRT machine using the 'touch' display screen.

Staff training continued once the study was underway to include supervision at the bedside to ensure the requirements of the study were upheld. The process of

treatment randomisation was observed and guidance offered to avoid procedural errors from occurring. Assistance was provided during the set-up of the CVVH circuit and agreement reached on the treatment dose to be delivered. Directions were given to support the nurse during the time when a crossover to the alternative treatment modality was imminent. Information about the study and what was required were contained in a manual and kept at the bedside whilst patients participated in the study. The nurse or medical officer could also access this manual online via the hospital's intranet website using the various computer desktops located in the department.

Statistical Analysis

The comparison of circuit life between CVVH and CVVHDf required statistical analysis on variables taken to detect a difference which was of clinical importance for determining the effectiveness of each treatment mode in the promotion of circuit life. The initial statistical work involved building a database and categorising the number of variables to be collected. On reaching the required number of participants the next stage involved comparisons between treatment groups and examination of consistency in the variables observed. This allowed the distribution of data to be assessed and the required transformation of data to compare the influence of treatment mode on circuit life. The inclusion of other variables and whether treatment mode alone was responsible for differences in circuit life completed the statistical work undertaken.

Database Development

A database was established using SPSS version 13 statistical analysis computer software (Chicago, Illinois) to enter categorical and continuous variables. The order of how each variable needed to be entered in the database was incorporated in the design and when data analysis was undertaken the structure of the database accommodated the specific statistical procedures required to answer the research question. Each variable was coded with a detailed codebook maintained for the meaning of names given and to provide a description of the values included in the database. The accuracy in the entry of data was verified using descriptive analyses and frequencies on each variable to prevent corruption of the database by missing data and out-of-range values. Once data had been entered in the database and checked for inaccuracies a number of data transformations were performed to allow easier interpretation of the data and increase the reliability of the results.

The data transformations undertaken included the grouping of circuits which had clotted according to treatment mode and the dispersal of circuit life measurements adjusted to accommodate normality of distribution. After data was drawn from the main database into a series of subsets each grouping of data was analysed by a variety of statistical procedures. The distribution of variables was examined using descriptive statistical procedures along with the measurement of relationships between different variables affecting circuit life. The detection of differences in circuit life between each treatment mode and the identification of possible causes was generalised to a wider population from the study sample using inferential statistical procedures.

Intention-to-Treat Principle

The intention-to-treat principle was adopted once consent to participate in the study had been granted by the patient or 'next-of-kin'. Unequal treatment distribution between CVVH and CVVHdf was a potential problem when compliance in mode allocation was threatened. The incorporation of an intention-to-treat principle allowed the analysis of data to be undertaken irrespective of whether the patient was given the sequence of treatments they were allocated to receive (Heritier, Gebiski, & Keech, 2003). During the study period the gathering of data was performed irrespective of protocol deviations or irregularities in the non-compliance of protocols or in the withdrawal of participants.

The inclusion of all patients in the study regardless of outcome provided a realistic account of actual clinical practice when evaluating circuit life using CVVH and CVVHdf. The inventory of events contained in the analysis recorded study violations which led to incomplete patient participation in the study after attempts were made to crossover and use the alternative treatment mode. Over estimation in the efficacy of an intervention can occur when some participants are deliberately removed and the results obtained not included when data is withheld from analysis (Heritier, et al., 2003). A number of clinical scenarios previously discussed as part of the crossover procedure were identified as possible causes of incomplete patient participation, with the responses to both treatment modes not able to be observed whilst candidates were enrolled in the study. The possible causes of events which prevented a treatment crossover to occur as shown in Figures 4.8 and Figure 4.9 included the return of urinary output and restoration of renal function or a decision to end treatment due to imminent death of the patient.

Sample Size Calculation

A number of statistical procedures are required in order to test whether a statement of hypothesis regarding an intervention is correct when the sample used is drawn from the wider population under investigation. The Central Limit Theorem states that for sample sizes greater than or equal to 30 drawn randomly the distribution of means are approximately evenly distributed (Pereira & Leslie, 2009). These remain constant even though the sample of data collected during the study may not resemble a normal distribution curve. In this study the response of CVVH and CVVHDf on circuit life can be tested for reliability using a random sample of patients to represent the general population of critically ill patients requiring CRRT. By formulating a null hypothesis, the response which is observed in this sample of patients can be tested on the basis that no difference was expected to occur (Pereira & Leslie, 2009).

The likelihood of rejecting a null hypothesis when a real difference does not exist is denoted as a type I error (Altman, 1991). Usually the Greek letter alpha (α) is used to describe the probability of a type I error. This is referred to as the significance level and 0.05 (5%) is one example of a significance level commonly used in statistical tests (Pereira & Leslie, 2009). A type II error on the other hand can falsely accept the null hypothesis when the opposite is true (Altman, 1991). Based on the statistical test used the study is powered to produce a calculated probability in the chances of not detecting a real difference. This probability is usually denoted by the Greek letter beta (β) and is often set at 0.2 (20%). The ability to reduce the chance of error by either wrongly rejecting or accepting the null hypothesis requires both α and β levels to be considered together. A statistical test which reduces the possibility of a type II error and a level of significance that minimises a type I error is usually recommended when undertaking hypothesis testing (Pereira & Leslie, 2009).

The various components which determine the sample size required to test the hypothesis depend on the level of significance and the power set by the investigator (Kirkwood, 1988). These sample size calculations will also be influenced by the degree of treatment response required to demonstrate the effectiveness of the intervention under investigation. A standard equation can be used for the purposes of sample size calculation, $n > 2k([\sigma] \text{ square})/(d) \text{ square}$, based on the minimal n that represents the required number, the variance of measured variable (denoted by σ square), the minimum difference of clinical significance (denoted by d) and the level of error in α and β values considered acceptable (denoted by k) (Columb & Stevens, 2008).

The sample size required for the study to detect a difference in circuit life between CVVH and CVVHdf was based upon professional statistical advice on sample size calculations. A threshold of 0.05 (5%) was established at the beginning of the investigation before measurements of circuit life were recorded. Once the study was completed, in the likelihood the obtained P-value showed a number lower than the pre-determined threshold and a positive effect was observed, the investigator is then prepared to accept a 5% chance that the difference in circuit life between CVVH and CVVHdf occurred erroneously. The study was also powered to show that the detected outcome between treatment mode and circuit life had an 80% chance of being correct, or a one in five chance (20%) of not detecting a real difference in the variable under investigation.

The underlying event rate of circuit failure due to clotting was another component considered in sample size calculations. Observations based on other studies which have investigated the same topic can provide valuable information on the lifespan expected to be achieved using different treatment modes and the degree of variance reported in the longevity of circuit life measurements. A preference for pre-dilutional CVVHdf at the study site had earlier recorded a mean circuit life of 16.2 hours and a SD of 13.4 hours (Leslie, 2003). In order to evaluate the size of effect using the alternative technique of CVVH, a difference in circuit life of four hours was considered a measurement which would offer a clinically meaningful outcome when compared with the lifespan of circuits observed using CVVHdf.

Using the aforementioned information a sample size of 30 patients exposed to both treatment modes was calculated as being sufficient to conduct a comparison of circuit life between CVVH and CVVHdf. The difference in means of each paired sample of circuit life was tested with a paired-sample t-test and since the difference could be in either direction a two-tailed test was selected. As a requirement of the statistical test the sample had to meet several assumptions. These assumptions included the SD of circuit life using CVVH would be the same as for CVVHdf and a positively skewed distribution curve could be normalised using logarithm transformation.

Assessing Normality

The initial analysis of possible differences in circuit life between CVVH and CVVHdf required measurements to be grouped together according to treatment mode. This enabled the distribution of measurements, recorded when each circuit had run its

natural course and taken down due to clotting, to be assessed for normality. A Kolmogorow-Smimov goodness-of-fit statistical test was carried out to determine the normality in the distribution of circuit life measurements recorded in minutes. The sample of circuit life measurements conformed to the assumptions underlying the Kolmogorow-Smimov test since measurements were from a random sample and data collected was from a continuous variable (Daniel, 2005). Circuit life measurements were shown to have a positive skewed distribution curve. In a positive skewed distribution curve the skewness or symmetry in the distribution of data is influenced by the frequency of low scoring measurements distinct from a normal distribution curve which is bell-shaped and symmetrical about the mean. The predominance of short circuit life in the study skewed the distribution curve positively and the uneven distribution observed matched that reported in a similar study measuring circuit life (Uchino, et al., 2003b).

In choosing to use a parametric statistical test the data set is assumed to be normally distributed and if skewed can invalidate the statistical technique (Altman, 1991). The advantage of parametric over non-parametric statistical techniques is the method used for estimation and hypothesis testing based on the central limit theorem. The central limit theorem is able to approximate the sample mean to the population mean provided the sample size is sufficiently large enough to observe the variations in the dependent variable (Chow & Liu, 2004). By using the central limit theorem a difference between groups in the case of the t-test and discovery of associations between variables with the Pearson's correlation test is more likely to occur with parametric than non-parametric statistical techniques.

A decision to use parametric statistical techniques resulted in choosing an option for analysis which would address the problem of violations in the normal distribution of circuit life measurements when comparisons were made between CVVH and CVVHdf. Modification of the dataset was selected as one approach which would allow parametric statistical tests to be undertaken. In statistics working with logarithms of data instead of actual measurements have several mathematical properties which in some cases allow the distribution of data to become more symmetrical than data which has not been transformed (Kirkwood, 1988). The process involves the transformation of every value in the dataset being replaced by its logarithm with only the base chosen determining the logarithm and not changing the measured value when the dataset is transformed. Mathematicians consider logarithms to the base e (\ln) a natural logarithm which can

simplify many formulae in the transformation of data which arises from nature when compared with the other commonly used logarithm to the base 10 (Evans, 1939). Using the process of data transformation the values obtained from circuit life measurements were mathematically formulated and following manipulation by the natural logarithm base e (ln) changed the positively skewed distribution curve to one which resembled a near normal dispersion of circuit life measurements. After completing the logarithm transformation the modified data set was subjected to parametric statistical testing using a paired-sample t-test.

Paired-sample t-test

A paired-sample t-test was selected to compare circuit life since CVVH and CVVHdf was administered to the same patient. The paired-sample t-test is a parametric statistical technique used when data is collected on the same group of individuals but during two different occasions or under two different conditions (Kirkwood, 1988). Once the assumption of normality in the distribution of circuit life measurements had been achieved by logarithm transformation a comparison of the mean performance in the lifespan of CVVHdf circuits was able to be made with that observed using the alternative treatment mode of CVVH.

Wilcoxon Signed Ranks Test

The other option for statistical testing was not to take the assumption of normality into consideration and instead compare circuit life measurements using a complementary non-parametric Wilcoxon signed ranks test. Non-parametric statistical techniques do not make assumptions about the underlying distribution of data when not shown to be normally distributed (Kirkwood, 1988). Instead of comparisons made between the mean scores, the Wilcoxon signed ranks test compares the median scores of the two groups. The scores are then converted on the continuous variable, in this case circuit life, to ranks and analysis undertaken of whether the ranks across the two groups, CVVH and CVVHdf, are significantly different.

Survival Analysis

A survival analysis is used in clinical studies when the research question requires the investigator to measure a predetermined outcome from the point of initiation to a fixed time or event (Daniel, 2005). Traditionally survival data analysis has been concerned with time to death after treatment but has been used in other areas

besides mortality to observe the response of a particular intervention. One field of enquiry where this type of statistical test has proved popular has been in the area of CRRT. A number of studies investigating this topic have used survival data analysis to make comparisons of circuit survival times (Prasad, et al., 2000; Reeves, et al., 1997). The statistical technique is able to determine the cumulative effect and probability of a specific event, in this case the time to circuit failure, and produce survival curves when data on circuit life measurements are plotted onto a graph. The distinguishing feature of survival data analysis is in some cases the event may not have occurred during the observation period. When the event is not observed survival time is reported to be censored.

The Kaplan-Meier method (E. L. Kaplan & Meier, 1958) was chosen to perform a survival analysis on the probability of circuit survival time for CVVH and CVVHDF. The length of time to the event of circuit failure due to clotting was recorded in minutes and represented a continuous time variable. This enabled the Kaplan-Meier method to be used for survival analysis as opposed to the alternative Cox Regression Model which is instead restricted to using time intervals when recording the event under investigation. Using the Kaplan-Meier method a survival analysis was performed on all circuits which had survived to clotting either as part of a treatment crossover or when taken down in isolation. The survival analysis on circuit life was also expressed as a measurement of the non-survival potential or hazard rate when comparing differences in circuit life using CVVH and CVVHDF. The circuit time of 960 min (16 hr) was used as the truncation point to determine the survival or failure rate of circuits using both treatment modes. This time was derived from past clinical experience using pre-dilutional CVVHDF at the study site. The truncation point represented a measurement of circuit life which has been reported by others using CVVH as sufficient to ensure adequate renal replacement therapy is delivered (Uchino, et al., 2003a).

Multiple Regression Analysis

A linear multiple regression analysis was undertaken on the 93 circuits which had survived to clotting. Multiple linear regression techniques investigate linear relationships between a set of independent variables against continuous dependent measurements (Draper & Smith, 1998). In the case of this study it was necessary to determine the relationship between the continuous dependent variable of circuit life against the independent variables of aPTT, platelets, heparin dose, haematocrit and urea. An important feature of multiple regression analysis is the ability to make predictions

about what the affect would be on the dependent variable when the outcome is measured against several independent variables (Draper & Smith, 1998). In order to determine whether the lifespan of the circuit as the dependent variable was solely due to the crossover between CVVH and CVVHDF it was necessary to explore the independent variables of aPTT, platelets, heparin dose, haematocrit and urea as predictors of circuit life. A number of different statistical tests are available for predicting the strength and direction in the relationship of individual variables with the dependent variable of interest to determine the response of a specific treatment.

Pearson's product-moment correlation

A Pearson product-moment correlation was used to determine whether the natural life of the 93 circuits which had clotted was influenced by differences in treatment mode alone and not by the other variables monitored which included measurements of aPTT, platelets, heparin dose, haematocrit and urea. This parametric statistical test is used for linear multiple regression analysis whereby all the independent variables are entered into the equation simultaneously and each variable is evaluated in terms of the effect each has on the other independent variables (Altman, 1991). As a precautionary measure in using multiple regression analysis which relies on a number of assumptions, the dataset was reviewed as part of the statistical test to determine compliance with the assumption of normality and the presence of outliers. The independent variables of platelets, haematocrit and urea were included in the multiple regression analysis, however heparin dose and aPTT values excluded since both variables could not be considered as independent of each other. A direct correlation between heparin dose and aPTT values was observed in one study when the impact of each variable was measured against circuit life (van de Wetering, et al., 1996). The presence of co-linearity amongst two variables can cause inaccuracies to occur and should be avoided when undertaking multiple regression analysis (Draper & Smith, 1998). Pearson product-moment correlation coefficients (r) range from -1 to +1 according to the linear relationship and whether it is a negative or positive correlation. A correlation that is either -1 or +1 indicates the relationship is perfect and the value of one variable is able to be determined if the other variable is known (Draper & Smith, 1998).

Spearman's Rank Order Correlation

A Spearman's Rank Order Correlation was undertaken for multiple regression analysis as a non-parametric alternative statistical technique to determine the existence or absence of a correlation which was different from those previously recorded using the alternative parametric statistical technique. The technique was applied to the 93 circuits which had survived to clotting and the potential for a correlation between the continuous dependent variable of circuit life observed against the independent variables of aPTT, platelets, heparin dose, haematocrit and urea.

Design Limitations

Although rigorous in approach this study was limited by a number of factors. It was a single-site analysis of circuit life in patients requiring CRRT as part of their clinical management in ICU. Operational variations in the application of CVVH and CVVHdf at the study site could be different to those carried out when the same treatment modes are performed in more than one ICU, and it is unknown if similar results would be obtained with different anticoagulation regimens or other types of vascular access catheters or the use of assorted CRRT machine hardware. While it was useful to determine if circuit life is extended by differences in treatment mode, due to the cross-over study design and daily blood sampling undertaken, it was not possible to evaluate the effectiveness on solute clearance between CVVH and CVVHdf. The nature of the intervention made it impossible to blind this kind of study and was open to bias if one treatment mode was seen by nursing staff as being more favourable in promoting circuit life or was viewed as easier to manage in the clinical setting.

Ethical Issues

The prospect of undertaking research involving the critically ill patient raises several important issues in regards to patient safety and the requirement for consent (Rischbieth & Blythe, 2005). The recruitment of patients who are critically ill comprise a cohort of individuals who are vulnerable and dependent on the Intensive Care Specialist and Critical Care Nurse for the supervision of treatment and in the delivery of care. Any investigator contemplating research involving the critically ill patient must have a sound knowledge of ethical principles governing the conduct of clinical studies and should be familiar with ethical guidelines followed by the institution where the study is planned to be undertaken. The research question under investigation and the conduct of this study was granted ethical approval by the Human Research Ethics

Committees at RPH, Edith Cowan University and Curtin University of Technology using guidelines consistent with those issued by the NHMRC on research involving humans (1999).

Patients admitted to ICU who required CRRT and enrolled to participate in this study were exposed to the same risks normally associated with extracorporeal renal support, but were open to the possibility of extended circuit life improving the effectiveness of the treatment being delivered. The risks associated with extracorporeal renal support were no different with CVVHdf than they were for CVVH. In view of the preference for CVVHdf at the study site the majority of nursing staff were unfamiliar with differences in the operational characteristics of CVVH, and it was necessary to provide training and supervision prior to and during the study period. Differences in the set-up and fluid exchanges required between the two treatment modes could lead to errors in fluid management and place the patient at risk of excessive removal or retention of body fluids.

The majority of patients who participated in the study were unconscious and unable to communicate normally due to impaired cognition as a result of sedation and the requirement for ventilatory assistance. In keeping with NHMRC guidelines involving unconscious persons highly dependent on medical care, permission to participate in the study was sought from individuals who had a close and continuing relationship with the patient (1999). The approach was made specifically to individuals who had been previously nominated by the patient as next-of-kin to make decisions and give consent on their behalf. Once the patient was no longer incapacitated the process followed for consent allowed the patient an opportunity to make a decision about whether to continue participation in the study.

Informed written consent was obtained from patients wherever possible prior to enrolment in the study, otherwise consent was sought from the patient's next-of-kin. A copy of the 'Information Sheet and Consent Form' used by the patient or next-of-kin to give authority for enrolment in the study is shown in Appendix C. Separate versions of the document were written and given to the patient and next-of-kin to reflect differences in wording required when providing an explanation of the study and what they were being asked to sign. Patients who were about to start or had already commenced CRRT were asked to consider whether they would agree to participate in this study. If the patient was incapable of speaking for themselves due to the severity of illness, the next-

of-kin was approached to voice an opinion on their behalf. The patient or next-of-kin were given an opportunity to ask questions before making a decision, with information about the study given verbally as well as in a written statement. The information sheet was kept by the patient or next-of-kin after the consent form had been signed. A copy of the consent form was given to the patient or next-of-kin whilst the patient's hospital identification number was attached to the signed original consent form and placed in the patient's medical notes for future reference. Patients who were initially incapable of informed consent but had participated in the study following next-of-kin consent were later given the opportunity to withdraw from the study. Initial consent to participate in this study was able to be withdrawn at anytime and had no effect on the patient's subsequent medical treatment.

Information collected from patients participating in the study complied with guidelines set out under the Privacy Act 1988 (Commonwealth) for the management and use of data containing personal information. Data obtained during the study was de-identified from the patient and coded to allow analysis capable of answering the research question. Storage of data was on-site at RPH secured in a locked filing cabinet or on computer where access was password protected. Access to data was only allowed by research personnel associated with the study, and by representatives of the hospital and university ethics committee assigned to review the validity and accuracy during the collection and in the reporting of data.

Summary

The research design and methodology used for this study was an attempt to adopt a rigorous approach in answering the research question. In choosing a randomised crossover research design the potential for bias in treatment selection was minimised and the affect on circuit life evaluated using the same patient to minimise differences in the severity of illness during sequential exposure to each treatment mode. The inclusion of power and calculation of sample size ensured that the study contained sufficient number of patients to compare circuit life. This was necessary to detect a difference in circuit life when patients were exposed to both treatment modes and make the prediction that the same result would occur again should the study be repeated on a similar group of patients. Using the patient as the control measure the approach was standardised for each treatment modality. The machine hardware and haemofilter were common to both CVVH and CVVHDf. Circuit life was compared with the same venous access catheter and vascular insertion site. Each circuit was exposed to a similar rate of

blood flow and the method used to anticoagulate the circuit did not differ. The process of standardisation allowed the investigation to separate circuit life as the variable of interest between the two treatment modes. Only circuits which had reached a natural circuit life were included and crossover to the alternative treatment mode suspended when the circuit was taken down for other reasons besides clotting. Measurements of circuit life were log transformed prior to undertaking a paired t-test in order to detect a mean difference in circuit life as the original data was not normally distributed. The cumulative effect of circuit life, when plotted onto a graph using survival analysis techniques, was used to identify differences in the probability of circuit survival for both treatment modes. A multiple linear regression analysis was undertaken to rule out the existence of relationships which would explain differences in circuit life other than the choice in treatment mode. The findings of parametric analysis were strengthened to exclude the potential for inconsistencies using non-parametric statistical procedures. Standards for research involving humans were in accordance with guidelines on ethical conduct imposed by hospital and university authorities during the investigation of circuit life using CVVH and CVVHDF.

CHAPTER 5

RESULTS

In this chapter data collected from patients who participated in the study between December 2004 and July 2006 is presented. The results contain analyses using descriptive statistics which included measures of central tendency and dispersion. Inferential statistics are also used on the sample of circuit life measurements observed during CVVH and CVVHdf. The linear relationship with independent variables associated with the two treatment modes is explored using parametric and non-parametric statistical tests.

Patient Characteristics

A total of 45 patients were recruited of whom 16 were women and 29 were men. The mean age of participants was 57.9 years, $SD \pm 15.6$ years. As shown in Table 5.1 there was a mixed group of surgical and medical patients. Major patient diagnostic categories included pneumonia, septic shock and ischaemic heart disease. The mean worst in first 24-hour APACHE II score of the 45 patients enrolled in the study was 25.5, $SD \pm 6.2$. The mean 24-hour APACHE II score for all patients admitted to ICU during the recruitment period was 17 for the period starting January 2005 and finishing January 2006 (RPH ICU Database). This suggests the majority of patients who were recruited during this time period with a higher illness severity APACHE II score had an increased risk of death when compared with other patients who did not require CRRT. Although 45 patients were randomised to receive CVVH and CVVHdf, the requirement for both circuits to have failed due to clotting, a successful crossover to the alternative technique only occurred in 31 patients. Despite the number of randomised patients not achieving a treatment crossover, the minimum sample size target of 30 patients was achieved as planned.

Table 5.1

Patient Characteristics

Patient No.	Age	Gender	APACHE II Score	Body Weight (kg)	Admission Diagnosis
1 _a	48	Female	29	92.3	Septic Shock
2 _a	40	Male	10	114	Septic Shock
3 _a	46	Female	23	84.5	Septic Shock
4 _a	64	Male	23	86.7	Cardiogenic Shock
5	57	Male	30	78	Septic Shock
6 _a	71	Female	21	60.5	Ischaemic Bowel
7 _a	42	Female	28	88.5	Septic Shock
8 _a	78	Male	31	76	Pneumonia
9 _a	62	Male	29	65.1	Pancreatitis
10 _a	66	Male	29	78	Septic Shock
11 _a	74	Male	21	109.3	Ischaemic Heart Disease
12 _a	73	Male	23	105.9	Septic Shock
13	71	Female	26	80	Septic Shock
14 _a	56	Male	21	81.3	Trauma
15 _a	72	Male	28	76.4	Pneumonia
16	63	Male	24	71.8	Cardiogenic Shock
17	59	Female	16	95.7	Pneumonia
18 _a	19	Female	32	68.1	Pneumonia
19	50	Female	17	88.5	Pancreatitis
20	53	Female	25	84.7	Pneumonia
21	63	Female	36	63.4	Ischaemic Bowel
22 _a	32	Male	36	94.4	Pneumonia
23 _a	53	Male	21	124.3	Septic Shock
24 _a	36	Male	23	100	Trauma
25 _a	41	Male	19	105	Septic Shock
26	57	Male	37	90	Cardiogenic Shock
27 _a	68	Male	27	111.8	Abdominal Aortic Aneurysm
28 _a	77	Male	24	91.9	Septic Shock
29 _a	65	Male	39	88.5	Abdominal Aortic Aneurysm
30	53	Male	23	111.7	Cardiogenic Shock
31	71	Female	36	80.3	Cardiogenic Shock
32 _a	82	Male	29	83.9	Pneumonia
33 _a	35	Female	18	99.3	Pneumonia
34 _a	47	Male	26	116.4	Pneumonia
35	73	Female	15	91.8	Ischaemic Heart Disease
36 _a	80	Male	22	82	Ischaemic Heart Disease
37 _a	70	Male	23	81.5	Pneumonia
38 _a	59	Male	22	97.4	Septic Shock
39 _a	55	Male	28	89.4	Septic Shock
40	70	Female	25	110.8	Chronic Renal Failure
41 _a	75	Male	19	59.1	Ischaemic Heart Disease
42	34	Female	34	76.4	Hepatic Failure
43 _a	36	Female	28	60.2	Pneumonia
44 _a	34	Male	27	63	Trauma
45	75	Male	26	106.5	Pneumonia

a. Successful treatment crossover

Randomisation

Out of 45 patients who participated in the study 21 patients were initially randomised to receive CVVH and 24 patients to CVVHDF. As a result of circuits taken down for reasons other than clotting, out of the 45 patients enrolled, cross-over to the alternative mode was not possible in 14 cases. This was due to death (3 patients), violations in study protocols (2 patients), stabilisation of the patient's condition allowing transfer out of the unit (1 patient), or elective discontinuation (8 patients). Clotting of the circuit in the remaining 31 patients occurred sequentially between the two modalities. Of the 31 patients who achieved a successful crossover 15 were initially randomised to receive CVVH and 16 to CVVHDF. A diagram illustrating the distribution in CRRT mode following randomisation and the number of successful versus unsuccessful treatment crossovers is shown in Figure 5.1.

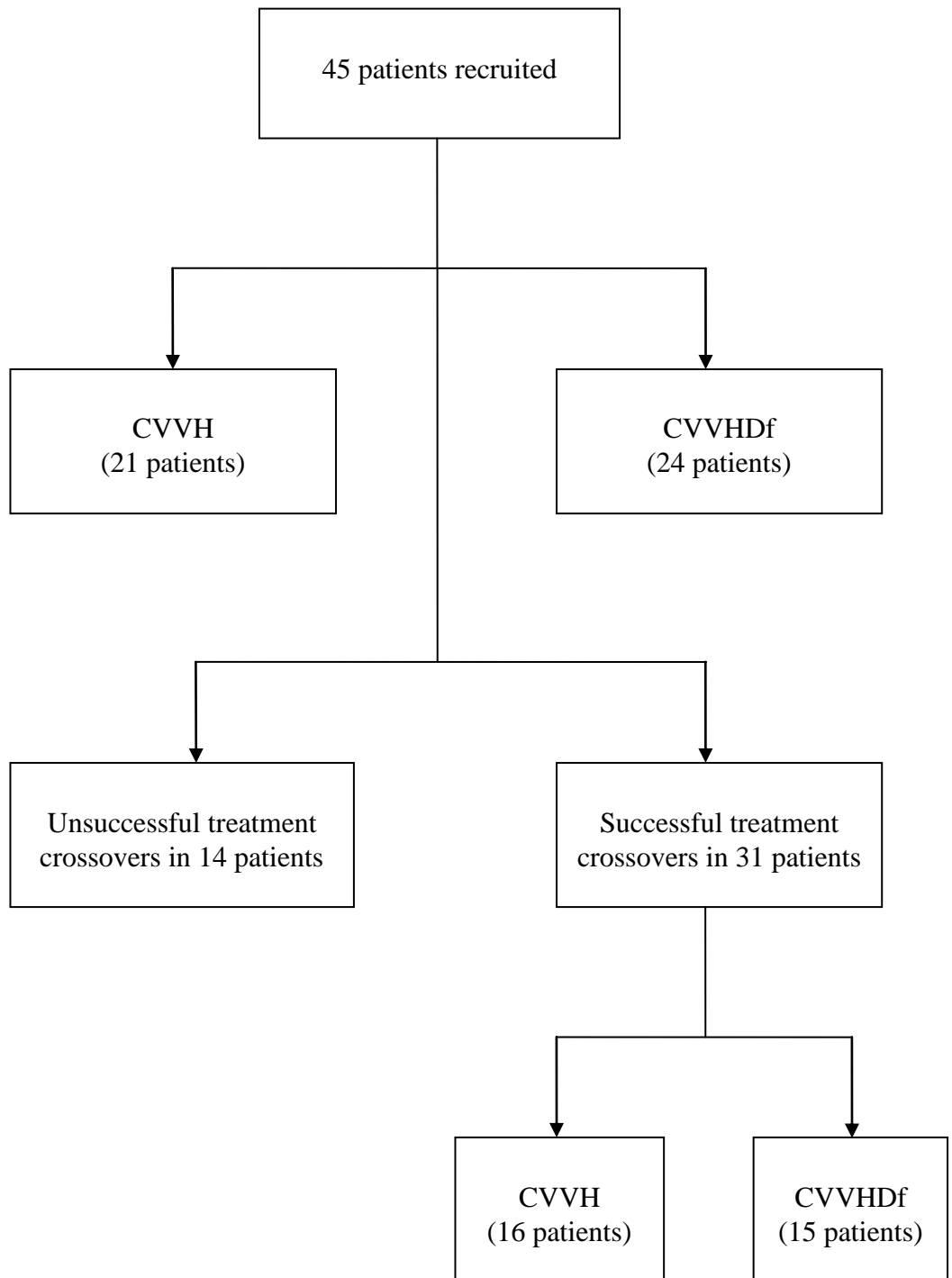

Figure 5.1. Mode of treatment distribution following initial randomisation and the number of successful versus unsuccessful treatment crossovers.

‘Natural’ Circuit Life

In the 45 patients treated 93 circuits reached a natural circuit life as previously defined. Of the 93 circuits, 62 were paired CVVH and CVVHdf circuits (31 of each), with the remaining 31 circuits reaching a natural circuit life but not able to be paired in

a crossover. Of the 93 circuits, 43 were CVVH circuits and 50 CVVHDf circuits had reached a natural circuit life. The bar chart shown in Figure 5.2 illustrates the 93 circuits and their respective circuit life in minutes. Blue coloured bars represent circuit life when treatment modality was by CVVH and the red coloured bars represent circuit life when treatment modality was by CVVHDf. A horizontal reference line has been drawn at 960 minutes which identifies the mean circuit life of 16.2hr which was previously recorded using CVVHDf as part of a quality improvement project conducted earlier at the study site (Leslie, 2003). Inspection of the bar chart reveals the majority of circuits (69) did not reach a lifespan that was greater than the 960min reference line. Out of the 24 circuits which exceeded the reference line a greater number occurred when the treatment modality was CVVHDf (21) compared to the treatment mode of CVVH (3).

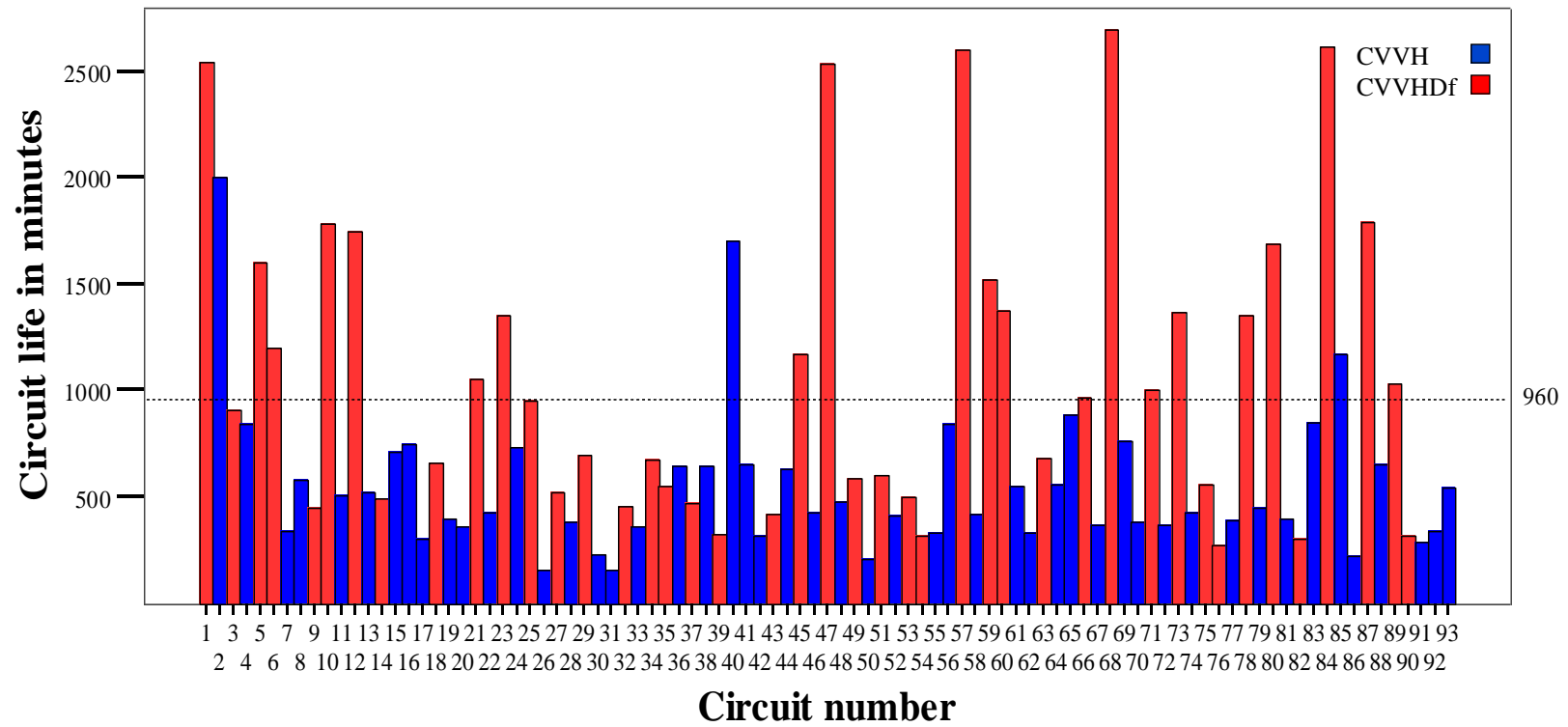

Figure 5.2. The circuit life of the 93 circuits which achieved a natural circuit life either in isolation or as part of a crossover.

Normality Tests

In order to determine what statistical approach should be taken in assessing circuit life differences the Kolmogorov-Smirnov goodness-of-fit statistical test was undertaken to evaluate the normality of data distribution. As shown in Table 5.2 the results from the Kolmogorov-Smirnov test (Statistic = 0.204, P-value = 0.000) indicate that the lifespan of the 93 circuits included in the sample does not have a normal distribution. Instead of a symmetrical bell-shaped distribution curve, the frequency of shortened circuit life caused the distribution curve to be positively skewed. The positively skewed distribution in circuit life measurements is demonstrated in Figure 5.3 when displayed as a scatter plot. Inspection of the scatter plot shows the observed values which are distributed along a curved line plotted against the expected linear measurements when normally distributed.

Table 5.2

The Kolmogorov-Smirnov goodness-of-fit statistical test for all circuit life measured in minutes

		All Circuit Life (min)
		n = 93
Normal Parameters	Mean	781.32
	Standard Deviation (SD)	602.016
Kolmogorov-Smirnov Z		0.204
Asymp. Sig. (2-tailed)		0.000

Normal Q-Q Plot of All circuit life in minutes

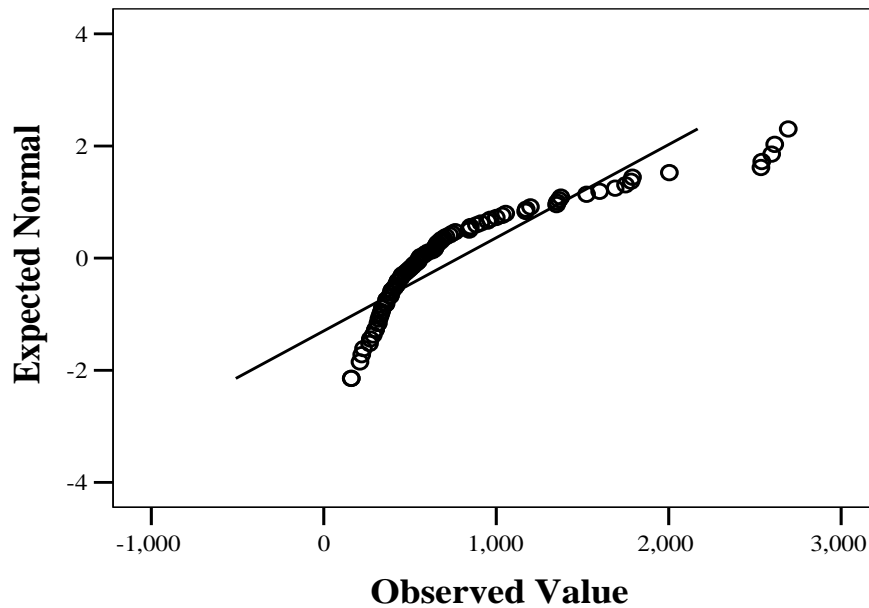

Figure 5.3. Circuit life measurements displayed as a scatter plot against expected measurements for a normal distribution.

Given the skewed data distribution, consideration was given to manipulating the data on circuit life measurements to allow the option of parametric as well as non-parametric statistical testing. Using the natural logarithm base e (\ln) dataset transformation, measurements of circuit life were mathematically formulated and modified to transform a positively skewed distribution curve to one that resembled a normal distribution. The distribution of logarithm transformed values was again evaluated for normality. As shown in Table 5.3 the Kolmogorow-Smirnov statistical test produced a non-significant result (Statistic = 0.755, P-value = 0.618) indicating after natural logarithm base e (\ln) dataset transformation the conditions of normality had been met by the mathematical manipulation of circuit life measurements. A repeat scatter plot of circuit life measurements after dataset transformation shown in Figure 5.4 reveals the distribution of values are in a reasonably straight line similar to the expected normal distribution of measurements.

Table 5.3
The Kolmogorov-Smirnov goodness-of-fit statistical test for all circuit life measurements after natural logarithm base e transformation (ln)

		All Circuit Life (min)
		n = 93
Normal Parameters a,b	Mean	6.429
	Standard Deviation (SD)	0.662
Most Extreme Differences	Absolute	0.078
	Positive	0.078
	Negative	-0.052
Kolmogorov-Smirnov Z		0.755
Asymp. Sig. (2-tailed)		0.618

a. Test distribution is Normal

b. Calculated from data

Normal Q-Q Plot of All Circuit Life Ln Log Transformation

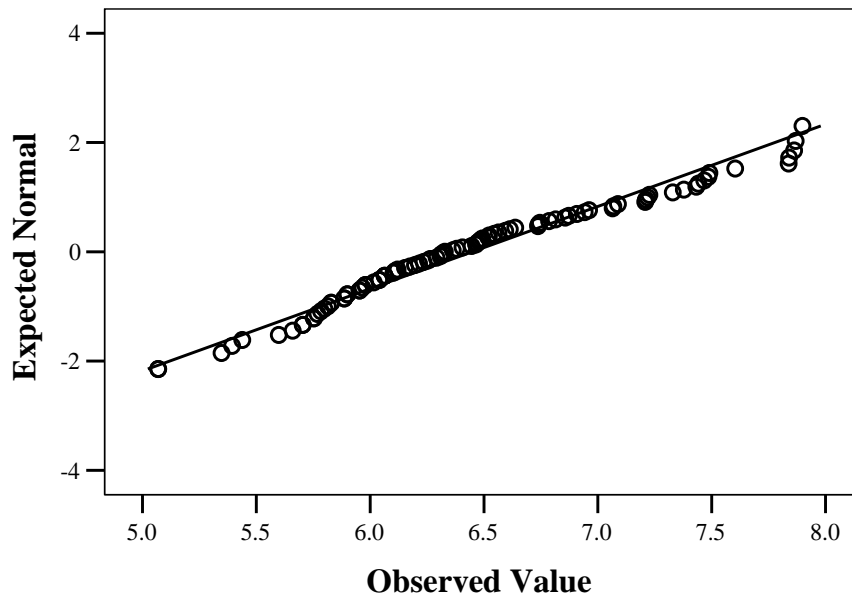

Figure 5.4. Circuit life measurements displayed as a scatter plot following natural logarithm base e (ln) dataset transformation against expected measurements for a normal distribution.

Sequential Treatment Crossovers

Sequential treatment crossovers and paired comparisons of circuit life occurred in 31 patients. To illustrate the pattern of the numerical difference in circuit life between the two modes of treatment, a bar chart shown in Figure 5.5 expressed the difference between each pair according to the order patients were recruited. The bar chart depicts circuit life in favour of CVVH as blue coloured bars and circuit life in favour of CVVHdf as red coloured bars. Several examples in the bar chart illustrate that in some cases there appeared to be large differences in circuit life for either treatment modes. For example the observed difference in circuit life for patient number one was in favour of CVVHdf with a longer circuit life of 536 min (8hr 56min) whilst for patient number 13 the difference in circuit life was in favour of CVVH with an extended circuit life of 320min (5hr 20min). Out of the paired circuits CVVHdf was observed in 25 patients to have a greater difference in circuit life compared with only six patients where the difference in circuit life was in favour of CVVH. Although the bar chart shows a difference in the pattern of circuit life which favoured CVVHdf, the estimated difference in circuit life favouring CVVH occurred throughout the duration of the study and not as a result of increased exposure to the 'new' treatment. This scattered result of circuit life shown in Figure 5.5 suggests the mode of treatment, rather than technique familiarity was possibly the dependent variable of differences observed in circuit life between CVVH and CVVHdf.

Pre-dilution Volume and Treatment Mode

Out of the 31 patients who achieved a successful treatment crossover the difference in pre-dilution volume delivered using CVVH varied considerably when compared with the volume of fluid delivered using the alternative technique of CVVHdf. As shown in Table 5.4 the difference in predilution volume delivered for each patient during a treatment crossover increased amongst patients who had large variations in body weight. The volume of replacement fluid required for CVVH was determined by body weight in contrast to the fixed volume of 600ml required for CVVHdf.

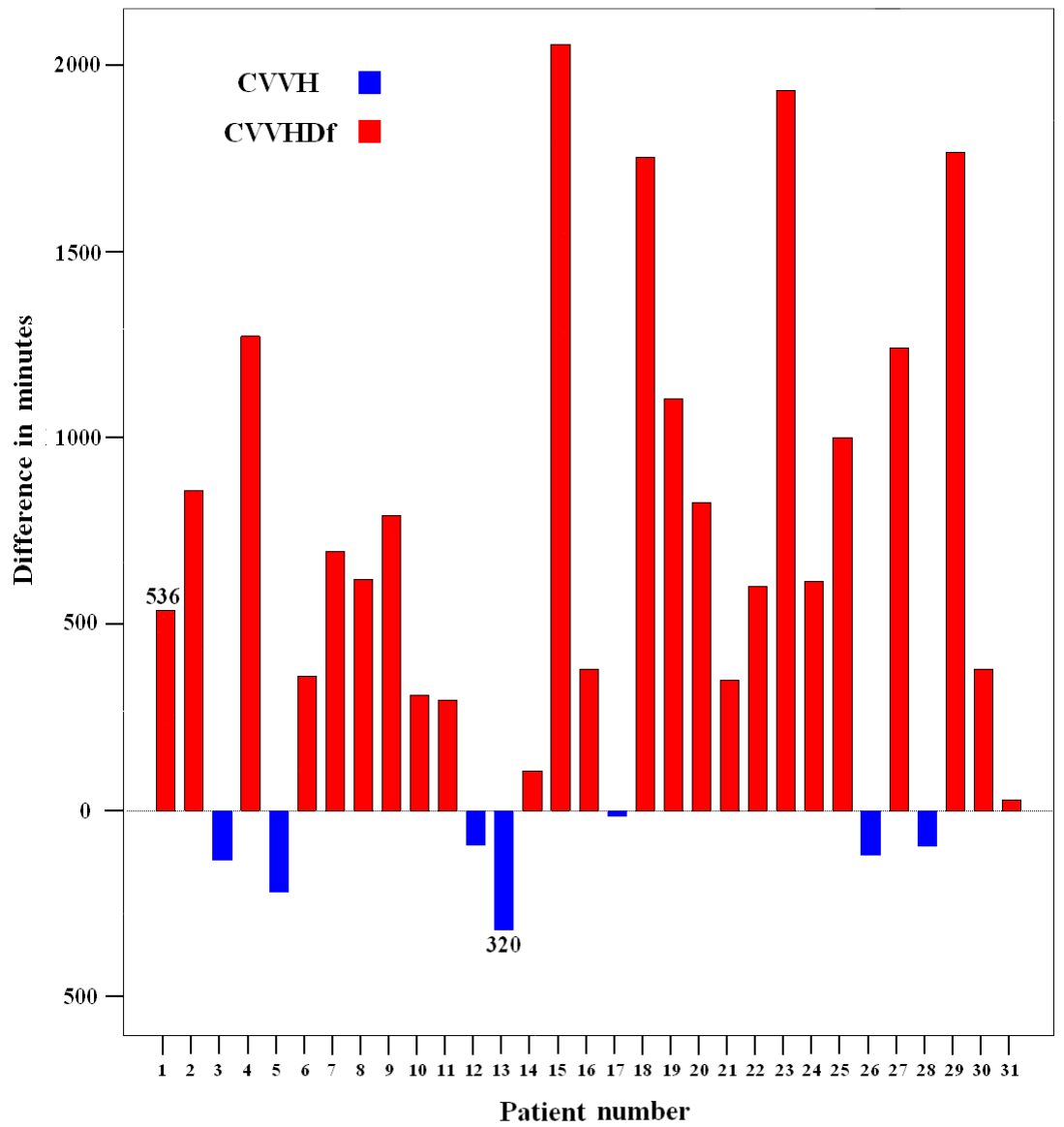

Figure 5.5. The pattern of paired difference in circuit life between CVVH and CVVHDF for 31 patients who received both techniques sequentially after each circuit had achieved a natural circuit life.

Table 5.4

Differences in pre-dilution volume of successful treatment crossovers according to body weight (CVVH) compared with a fixed pre-dilution volume of 600ml (CVVHdf)

Body Weight	Pre-dilution Volume CVVH (35ml/kg/hr)	Pre-dilution Volume CVVHdf	Difference in Pre-dilution Volume
92kg	3220ml/hr	600ml/hr	2620ml
114kg	3990ml/hr	600ml/hr	3390ml
85kg	2975ml/hr	600ml/hr	2375ml
87kg	3045ml/hr	600ml/hr	2445ml
61kg	2135ml/hr	600ml/hr	1535ml
89kg	3115ml/hr	600ml/hr	2515ml
76kg	2660ml/hr	600ml/hr	2060ml
65kg	2275ml/hr	600ml/hr	1675ml
78kg	2730ml/hr	600ml/hr	2130ml
109kg	3815ml/hr	600ml/hr	3215ml
106kg	3710ml/hr	600ml/hr	3110ml
81kg	2835ml/hr	600ml/hr	2235ml
76kg	2660ml/hr	600ml/hr	2060ml
68kg	2380ml/hr	600ml/hr	1780ml
94kg	3290ml/hr	600ml/hr	2690ml
124kg	4340ml/hr	600ml/hr	3740ml
100kg	3500ml/hr	600ml/hr	2900ml
105kg	3675ml/hr	600ml/hr	3075ml
112kg	3920ml/hr	600ml/hr	3320ml
92kg	3220ml/hr	600ml/hr	2620ml
89kg	3115ml/hr	600ml/hr	2515ml
84kg	2940ml/hr	600ml/hr	2340ml
99kg	3465ml/hr	600ml/hr	2865ml
116kg	4060ml/hr	600ml/hr	3460ml
82kg	2870ml/hr	600ml/hr	2270ml
82kg	2870ml/hr	600ml/hr	2270ml
97kg	3395ml/hr	600ml/hr	2795ml
89kg	3115ml/hr	600ml/hr	2515ml
59kg	2065ml/hr	600ml/hr	1465ml
60kg	2100ml/hr	600ml/hr	1500ml
63kg	2205ml/hr	600ml/hr	1605ml

Circuit Life during CVVH and CVVHDF

The descriptive measurement of circuit life for each treatment mode suggested lifespan differences shown in Table 5.4 occurred between CVVH and CVVHDF. The estimated mean circuit life for CVVH was eight hours 33min (SD±5hr 35 min) with an estimated median circuit life of six hours 35min and an estimated range of 30hr 45min. In comparison the mean circuit life for CVVHDF was 18hr 42min (SD±13hr 3 min), with a median circuit life of 16hr 5min and a range of 40hr 23min.

Table 5.5
Descriptive statistics of circuit life during CVVH and CVVHDF

Treatment Modality	Descriptive Statistic	
CVVH		
Mean	513.32min	(8hr and 33min)
Median	395min	(6hr and 35min)
Standard Deviation (SD)	335.21min	(5hr and 35min)
Minimum	159min	(2hr and 39min)
Maximum	2004min	(33hr and 24min)
Range	1845min	(30hr and 45min)
CVVHDF		
Mean	1122.13min	(18hr and 42min)
Median	965min	(16hr and 5min)
Standard Deviation (SD)	782.89	(13hr and 3min)
Minimum	270	(4hr and 30min)
Maximum	2693	(44hr and 53min)
Range	2423	(40hr and 23min)

Comparison of Circuit Life

Based not only on the transformed but also on the raw data distributions, the comparison of circuit life between CVVH and CVVHDf was made using both parametric and non-parametric statistical tests. The (parametric) paired-sample t test was applied to the normalised natural log transformed dataset and investigated the difference between the two sample means. The (non-parametric) alternative Wilcoxon signed ranks test was also carried out using the raw dataset. Application of both approaches was undertaken to demonstrate there was enough evidence from the datasets for the results to be considered statistically significant.

Paired-sample t-test

A paired-samples t-test was performed on the 31 paired circuit life comparisons for CVVH and CVVHDf using a natural logarithm base e (ln) logarithm transformation. This transformation was used to normalise the observed values of the paired circuit life so that the parametric test would be applied without violating the normality assumption. The transformed means and transformed standard deviations for both circuit life measurements are shown in Table 5.5. The t-test results for the transformed data set are shown in Table 5.6. Note that the mean difference was considered to be statistically significant and its P-value was 0.001.

Table 5.6

The transformed means and standard deviations (SD) for circuit life (CVVH and CVVHDf)

	Means	Standard Deviations (SD)
CVVH	6.101	0.516
CVVHDf	6.779	0.726

a. Natural logarithm base e transformation (ln)

Table 5.7

The parametric paired-sample t-test for 31 transformed comparisons of CVVH and CVVHDf circuit life

Mean	SD	SE a	95% CI b	t	df	P-value c
0.679	0.665	0.119	(0.435, 0.923)	5.682	30	0.001

a. Standard Error of the Mean (SE)

b. 95% Confidence Interval for the Mean (Lower, Upper)

c. P-value based on a two-tailed test

Wilcoxon Signed Ranks Test

The non-parametric Wilcoxon signed ranks test was applied to the raw data set and the Z-statistic was calculated based on the rank order for the 31 paired comparisons. The results are shown in Table 5.7 and there was enough evidence from the data set to suggest that there was a significant difference in circuit life between CVVH and CVVHDf ($Z = -4.076$, $P\text{-value} < 0.001$).

Table 5.8

The non-parametric Wilcoxon signed ranks test for 31 comparisons of CVVH and CVVHDf circuit life.

	N	Mean Rank	Sum of Ranks	Ties c	Total	Z d	P-value e
Negative Ranks	7 a	5.71	40.00	0	31	4.076	<0.001
Positive Ranks	24 b	19.00	456.00		6		

a. CVVHDf circuit life in minutes < CVVH circuit life in minutes

b. CVVHDf circuit life in minutes > CVVH circuit life in minutes

c. CVVHDf circuit life in minutes = CVVH circuit life in minutes

d. Statistic test: Z distribution

e. P-value based on a two-tailed test

Survival Analysis

A survival analysis was performed to appreciate the characteristics over time of circuit survival for both modes of CRRT studied. The survival curves for CVVH and CVVHdf are shown in Figure 5.6 after the probability of circuit survival time was estimated using Kaplan-Meier survival analysis.

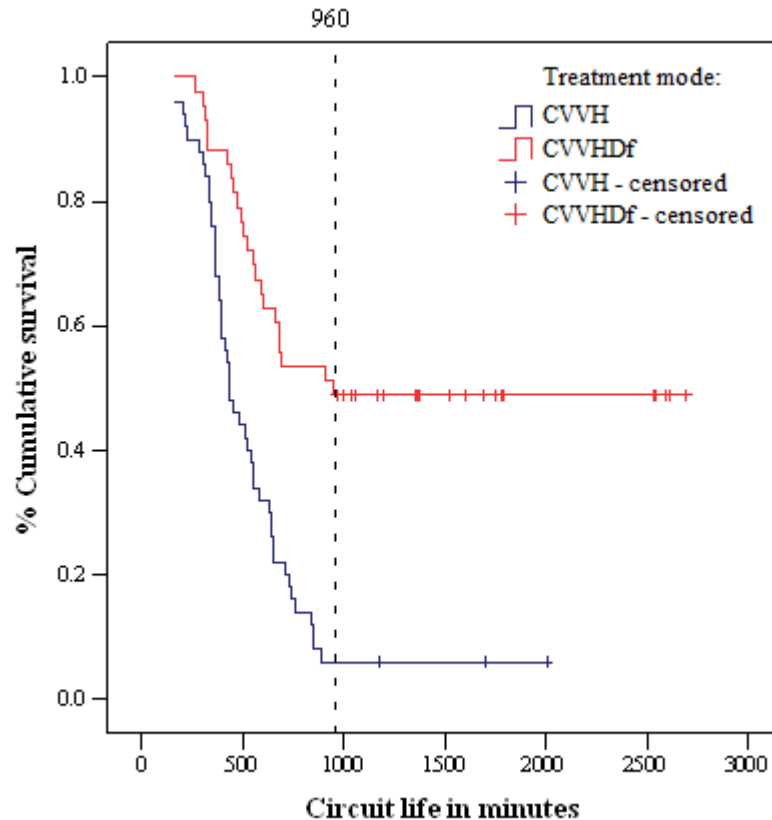

Figure 5.6. The Kaplan-Meier (percentage cumulative) survival curves for CVVH and CVVHdf treatment modes (Note the fixed truncation time line at 960 minutes was based on earlier data from the study site).

The analysis was performed on all 93 circuits which had reached a natural circuit life. The blue curve represents the survival of CVVH circuits and the red curve the survival of CVVHdf circuits. At zero minutes, that is the commencement of treatment, there is 100% survival of all circuits using the method of Kaplan-Meier for the survival analysis. After 500min (8hr 20min) there is a 40% chance of survival for CVVH circuits compared with CVVHdf circuits which at the same point in time have an 80% chance of survival. The mean circuit life of 960min (16hr) observed earlier at the study site (Leslie, 2003) was used as a predetermined truncation point for circuit life when comparisons of each treatment modality were made. The difference in chances of

survival between both treatment modalities increased to a 50% chance of CVVHdf circuits in operation at the predetermined truncation of 960min compared to the likelihood of only a 5% chance for CVVH circuits. The survival of circuits when expressed as a measurement of non-survival potential between the two treatment modalities is shown in Figure 5.7. The graph depicts the hazard or failure rate for CVVH circuits in blue and for CVVHdf circuits in red. At the truncation point of 960min the cumulative risk of circuit failure is lower with CVVHdf at 0.6, whilst the risk of circuit failure is higher at 2.5 using CVVH.

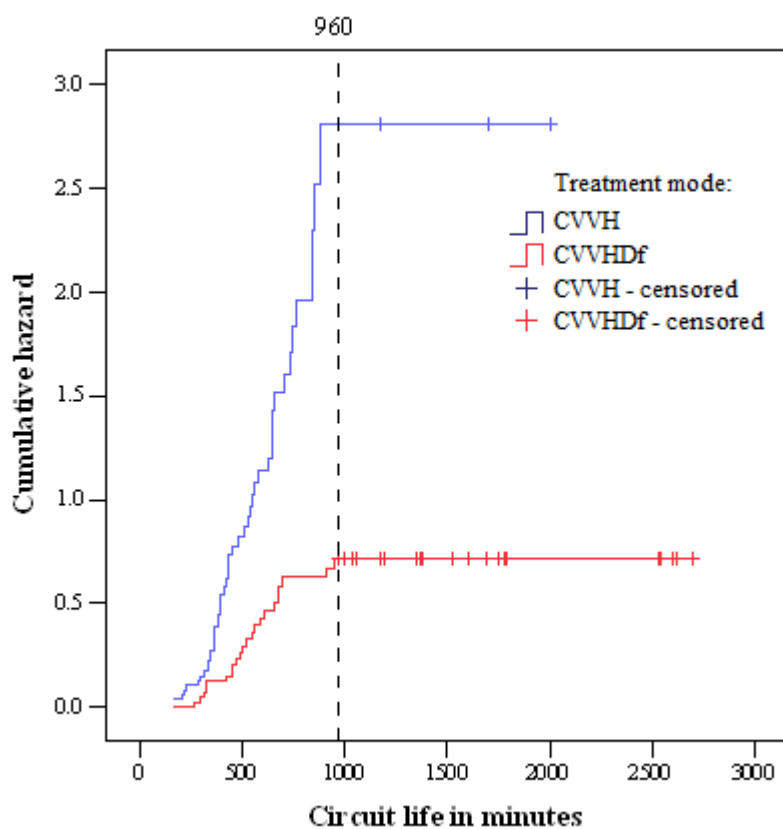

Figure 5.7. The hazard or failure rate of circuit survival between CVVH and CVVHdf.

A Multiple Linear Regression Analysis

A multiple linear regression analysis on the 93 circuits which had reached a natural circuit life and inclusive of the 31 paired comparisons formed the next and final stage of the statistical analysis. Exploration of linear relationships amongst variables was considered to determine whether circuit life was influenced by differences in

treatment mode alone, or influenced by exposure to other factors which could have impacted upon circuit life. The multiple linear regression analysis involved the evaluation of linear relationships or correlations between several independent variables against the dependent variable of circuit life.

Before conducting a correlation analysis a scatter plot was examined to check for possible violations of normality assumption. The Normal Probability Plot shown in Figure 5.8 displays the residual differences between the obtained and predicted values of the natural logarithm base e (\ln) circuit life measurements.

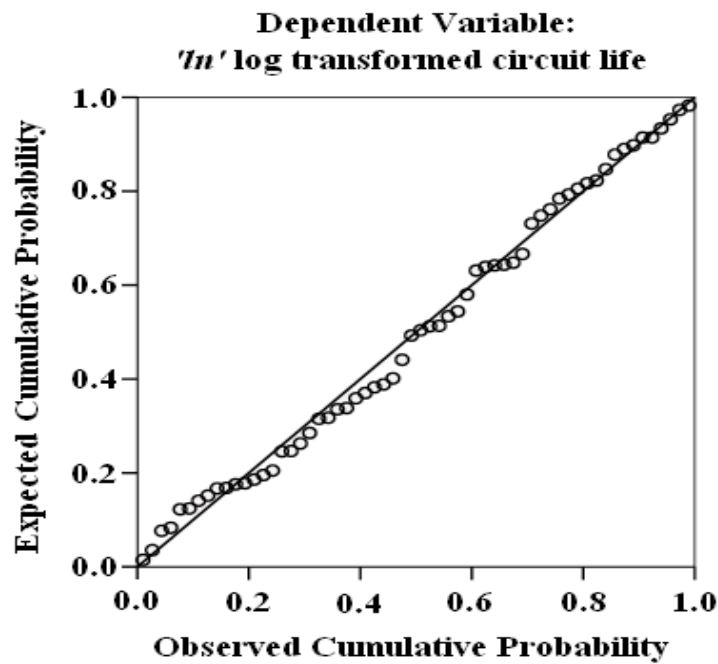

Figure 5.8. The Normal Probability Plot of the natural logarithm base e (\ln) circuit life measurements for the residual differences between the obtained and predicted values.

This was generated as part of the multiple linear regression analysis which assumes measured differences are normally distributed. The residual differences appeared to be lying in a line which is reasonably straight. A Normal Probability Plot showing points which are approximately in a straight line indicate normality in the distribution of measurements (Draper & Smith, 1998). The assumption of normality in the transformed distribution of the circuit life measurements is also investigated by a second plot (a scatter plot) generated from the multiple linear regression analysis. The scatter plot shown in Figure 5.9 of residual measurements against predicted values of the dependent variable is roughly located around the zero reference line.

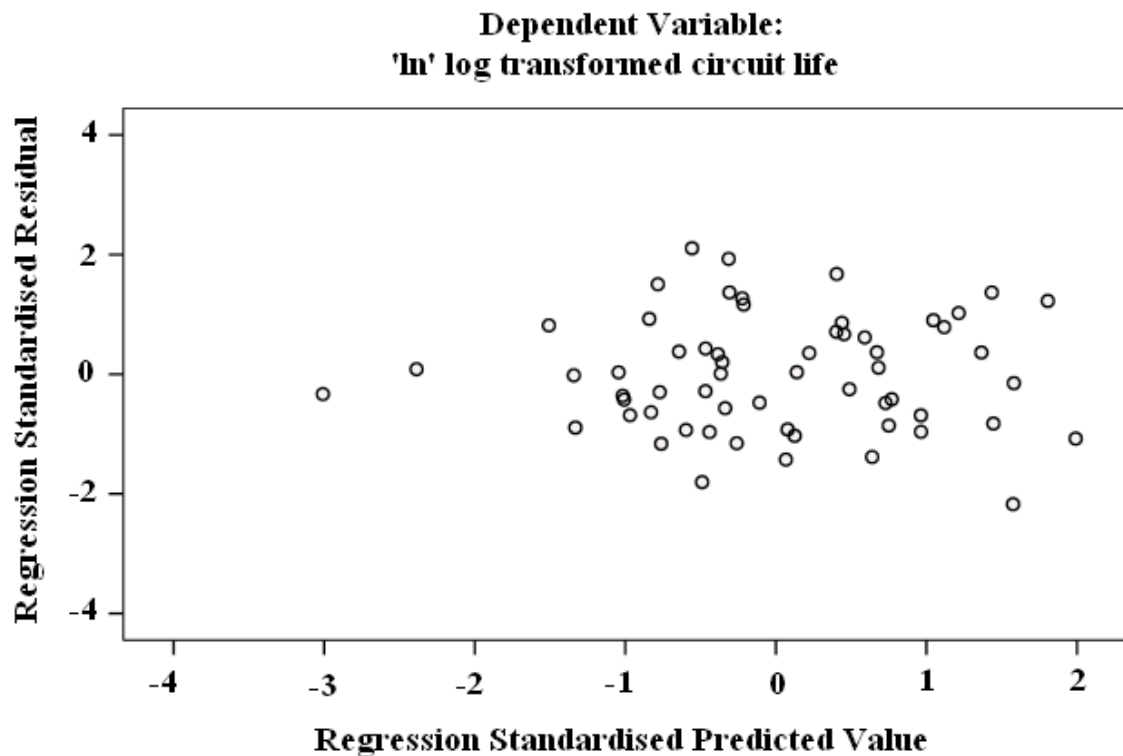

Figure 5.9. Scatter plot of residual measurements against predicted values of the dependent variable.

Most of the values are concentrated in the centre along the zero reference line. A scatter plot that is centralised suggests normality in the distribution of measurements (Draper & Smith, 1998). Review of the scatter plot also shows the absence of significant outliers. Tabachnick and Fidell (2001) define outliers as standardised residual values which are greater than 3.3 or less than -3.3. None of the standardised residual values in the scatter plot are greater than 2 or less than -3. Once it had been established that the distribution and shape of the scatter plot indicated measurements were roughly linear and randomly spread, a Pearson's product-moment correlation was performed.

Pearson's product-moment correlation

A Pearson product-moment correlation (parametric) test was chosen to evaluate the strength and direction of linear relationships between the dependent variable of circuit life and five independent variables. As shown in Table 5.8 the number of variables which were paired together totalled 60 and provided a sufficient quantity of pairs for the correlation analysis not to be influenced by the prevalence of missing data. A weak linear relationship with the independent variables of aPTT, platelets, heparin dose, haematocrit and urea was observed with the dependent variable of circuit life. None of the independent values had a correlation value greater than 0.4 or less than -0.4

indicating the strength of relationship was considerably weak. Out of the independent variables tested none were shown to have a correlation with each other which was statistically significant apart from the effect of heparin on aPTT (P-value = 0.011) and the impact of urea on both aPTT (P-value = 0.004) and platelets (P-value = 0.028).

Table 5.9

A linear multiple regression analysis demonstrating a weak correlation between the continuous dependent variable of circuit life against the independent variables of aPTT, platelets, heparin dose, haematocrit and urea

Statistical test		'ln' log transformed circuit life	aPTT in seconds	Platelets	Heparin dose in units/kg/hr	Haematocrit	Urea
Pearson Correlation	'ln' log transformed circuit life	1.000	0.145	-0.184	0.158	0.016	-0.174
	aPTT in seconds	0.145	1.000	-0.023	-0.297	-0.074	-0.344
	Platelets	-0.184	-0.023	1.000	0.092	0.052	0.247
	Heparin dose in units/kg/hr	0.158	-0.297	0.092	1.000	0.143	0.189
	Haematocrit	0.016	-0.074	0.052	0.143	1.000	0.079
	Urea	-0.174	-0.344	0.247	0.189	0.079	1.000
N	60	60	60	60	60	60	60

Table 5.9 (Cont'd)

		'ln' log transformed circuit life	aPTT in seconds	Platelets	Heparin dose in units/kg/hr	Haematocrit	Urea
	'ln' log transformed circuit life	-	0.134	0.079	0.114	0.451	0.091
	aPTT in seconds	0.134	-	0.429	0.011	0.288	0.004
P-value (1-tailed)	Platelets	0.079	0.429	-	0.243	0.348	0.028
	Heparin dose in units/kg/hr	0.114	0.011	0.243	-	0.138	0.074
	Haematocrit	0.451	0.288	0.348	0.138	-	0.274
	Urea	0.091	0.004	0.028	0.074	0.274	-
	N	60	60	60	60	60	60

The model summary of the multiple linear regression analysis displayed in Table 5.9 shows the estimated determination coefficient (R Square value) to be 0.117. The R Square value refers to the degree of variance in the dependent variable of circuit life which could be attributed to the independent variables of aPTT, platelets, heparin dose, haematocrit and urea. When the R Square value is expressed as a percentage the variance in circuit life is explained as a 12% chance that the variance observed in the dependent variable was caused by the independent variables.

Table 5.10

The model summary of the multiple linear regression analysis showing the degree of variance in the dependent variable of circuit life which could be attributed to the independent variables of aPTT, platelets, heparin dose, haematocrit and urea

R	R Square	Adjusted R Square
0.342	0.117	0.035

The analysis of variance for multiple independent variables (ANOVA) statistical test (Draper & Smith, 1998) shown in Table 5.10 shows an estimated P-value of 0.228 indicating that there was no linear relationship between the studied dependent and independent variables.

Table 5.11

Analysis of variance (ANOVA) between the dependent variable of circuit life and the independent variables of aPTT, platelets, heparin dose, haematocrit and urea

	Sum of Squares	df	Mean Square	F	P-value
Regression	2.870	5	0.574	1.432	0.228
Residual	21.641	54	0.401		
Total	24.511	59			

The final step of the multiple regression analysis required the evaluation of each independent variable to determine whether any of these variables contributed more than the other in the prediction of the dependent variable of circuit life. In Table 5.11 the estimated standardised coefficients (Standardised Beta values) are listed under the column labelled Standardised Coefficients, the independent variables of aPTT, platelets, heparin dose, haematocrit and urea have been converted to the same scale in order for a comparison to be made on the effect each of the independent variables had on circuit life. The individual contribution associated with influencing circuit life was heparin dose with a Beta Standardised Coefficient value of 0.246. None of the Beta Standardised Coefficient values of the independent variables including heparin dose appeared to be less than the significance value of 0.05.

Table 5.12
Estimated standardised coefficients (Beta values) for each independent variable

	Standardised Coefficients	
	Beta	P-value
aPTT in seconds	0.174	0.223
Platelets	-0.174	0.195
Heparin dose in units/kg/hr	0.246	0.076
Haematocrit	0.012	0.925
Urea	-0.119	0.403

Spearman's Rank Order Correlation

The strength of the linear relationship between the dependent variable of circuit life and the independent variables of aPTT, platelets, heparin dose, haematocrit and urea was calculated using the alternative non-parametric Spearman's Rank Order Correlation statistical test. None of the independent variables shown in Table 5.12 indicated to have a linear bivariate correlation with the dependent variable. However, among the bivariate

linear Spearman's correlation coefficients of the independent variables, there appeared to be a significant correlation between urea and aPTT (Spearman correlation coefficient = -0.409 and P-value = 0.001).

Table 5.13

The bivariate linear Spearman's Rank Order Correlation between the continuous dependent variable of circuit life and the converted measurements of the independent variables of aPTT, platelets, heparin dose, haematocrit and urea (Note that all the measurement units have been converted to the same scale).

Statistical test		Circuit life	aPTT	Platelets	Heparin	Haematocrit	Urea
Correlation coefficient	Circuit life	1.000	0.182	-0.101	0.071	0.093	-0.193
	aPTT	0.182	1.000	0.083	-0.187	-0.012	-0.409
	Platelets	-0.101	0.083	1.000	0.154	0.028	0.026
	Heparin	0.071	-0.187	0.154	1.000	0.188	0.089
	Haematocrit	0.093	-0.012	0.028	0.188	1.000	0.074
	Urea	-0.193	-0.409	0.026	0.089	0.074	1.000

Table 5.13 (Cont'd)

		Circuit life	aPTT	Platelets	Heparin	Haematocrit	Urea
	Circuit life	-	0.132	0.425	0.503	0.462	0.123
	aPTT	0.132	-	0.523	0.124	0.926	0.001
P- value (2- tailed)	Platelets	0.425	0.523	-	0.226	0.827	0.841
	Heparin	0.503	0.124	0.226	-	0.136	0.483
	Haematocrit	0.462	0.926	0.827	0.136	-	0.568
	Urea	0.123	0.001	0.841	0.483	0.568	-

Summary

The results based on the statistical analyses contain several important findings. A broad range of conditions was represented in the sample of patients exposed to both treatment modalities and could be considered representative of patients' who require CRRT at the study site. Distribution in the sequence of modes between CVVH and CVVHdf was randomly assigned with no treatment modality being repeatedly selected over another. Therefore the assignment would minimise the possibility of one mode being influenced by timing within the exposure to patient characteristics associated with the course of disease progression. For instance, higher urea values associated with the initiation of CRRT. A significant mean difference in circuit life was observed between CVVH and CVVHdf in 31 paired comparisons with patients acting as their own controls using a sequential crossover method. Out of the 93 circuits which had reached a natural circuit life regardless of whether they had been paired with the alternative treatment modality, the strength of linear relationship between the dependent variable of circuit life appeared to not be significant with the measurement of other independent variables. The results indicate significant differences in circuit life. The differences conferred a circuit survival advantage for CVVHdf over CVVH.

CHAPTER 6

DISCUSSION

The principal aim of this research was to measure and compare the lifespan of CRRT circuits according to differences in pre-dilution volume associated with the techniques of CVVH and CVVHDF. A statistically significant improvement in circuit life using CVVHDF was observed when compared with the circuit life achieved during CVVH. The difference in circuit life between the two modes of treatment was substantial and clinically significant with CVVHDF shown to reduce treatment ‘down time’ associated with circuit failure and thereby better meet the continuous requirement of RRT delivery to the patient.

Acute Kidney Injury leading to the development of severe ARF is a serious complication impacting upon the survival and recovery of critically ill patients (Thakar, Christianson, Freyberg, Almenoff, & Render, 2009). The option for extracorporeal RRT in the ICU setting has initially been limited to conventional IHD. The technique was associated with fluid management and haemodynamic problems when the approach was applied to the critically ill patient. In efforts to overcome these problems a continuous approach to RRT was developed (S. John & Eckardt, 2007; Kramer, et al., 1980). The original CRRT concept (such as CAVH and CAVHD) which relied on the patient’s arterial blood pressure gave way to pumped veno-venous circuits and the techniques of CVVH and CVVHDF in recognition of improved ultrafiltration performance without the requirement for arterial cannulation (Storck, et al., 1991). Other improvements made during the development of CRRT have followed further advances in extracorporeal membrane technology and the growth of purpose-built machines (Ricci, et al., 2004). Some of these technological improvements have been transferred across and are now used in the application of IHD where contemporary practice reduce episodes of hypotension and the evolution of hybrid therapies allow greater flexibility in fluid balance control (van Biesen, et al., 2007).

Although the practice of CRRT has been adopted by many as the preferred method to support renal function in the ICU (Ronco & Bellomo, 2007), others do not support the abandonment of intermittent therapies unless a clear advantage in using CRRT can be established (Himmelfarb, 2007). Any future comparison between CRRT

and IHD is unlikely to show a difference in patient outcomes when the advantages and disadvantages of both techniques are not singled out. Attempts made to define the value of CRRT based solely on patient survival have proven elusive and possibly too simplistic given the manifestation of ICU ARF as part of MOD syndrome (Uchino, et al., 2005). The demonstration of a benefit may instead be influenced by the approach taken during the course of treatment rather than the choice of technique being superior. A clear advantage in choosing CRRT over IHD is demonstrated by the ability over time to achieve physiological stability and greater flexibility in fluid and nutritional support.

The continuous approach has emerged following the ATN (Acute Renal Failure Trial Network, 2008) and RENAL (RENAL Replacement Therapy Study Investigators, 2009) studies as the most appropriate form of RRT for vasopressor dependent patients when they are most vulnerable to changes in haemodynamic stability and a reduced capacity to maintain adequate organ perfusion pressure. In the context of MOD the technique of CRRT is comparable to the similar uninterrupted use of mechanical ventilation as a continuous support measure for the management of respiratory failure. Attention should now focus on the superiority of CRRT to achieve slow removal of excess fluid and correct biochemical abnormalities in the presence of haemodynamic instability which may have a beneficial effect on facilitating the return of kidney function and offer protection in the failure of other organs.

The actual delivery of less than the prescribed dose to patients receiving CRRT has been identified as a specific problem. This occurs predominantly due to interruptions to the continuous nature of the technique leading to a reduction in the delivered dose. In two retrospective studies only 68% to 78% of patients treated with CRRT were found to have been delivered the prescribed dose (Uchino, et al., 2003a; Venkataraman, Kellum, & Palevsky, 2002). The clinical significance of delivery of less than the prescribed dose is uncertain. Although the ATN (Acute Renal Failure Trial Network, 2008) and RENAL (RENAL Replacement Therapy Study Investigators, 2009) studies did not show patient outcomes were improved when the intensity of treatment dose was increased above standard practice (20ml per kg per hr), the importance of achieving a minimum treatment threshold is necessary for the patient to receive adequate renal replacement and clinical benefit from the intervention. At what level the dosing threshold is, requires further investigation. Nevertheless, when seeking to improve treatment delivery the ability to achieve a predetermined dose is an important aspect of clinical practice. Some authors have expressed the opinion the

intensity of renal support prescribed against the actual dose delivered to the patient requires greater scrutiny (Overberger, et al., 2007). It is against this background an investigation of possible differences in circuit life between the techniques of CVVH and CVVHDf was considered appropriate in order to determine whether selection of mode influenced continuity of treatment. Although several studies discussed in the literature review have investigated the question using the same or different treatment modes none of the studies reviewed were designed as a prospective randomised crossover investigation.

Circuit Life with CVVH and CVVHDf

The objective of this research project was to evaluate the effect on circuit life of a higher patient adjusted pre-dilution dose volume associated with CVVH when compared to CVVHDf and the delivery of a lower fixed pre-dilution and dialysate volume. This was accomplished using a randomised comparative crossover study design using a sample of patients drawn from a single centre who required CRRT as part of their treatment in ICU. In comparison with the mean circuit life of eight hour and 33min for CVVH, the use of CVVHDf extended the lifespan by almost 12hr with a mean circuit life of 18hr and 42 min. The shorter circuit life experienced with CVVH occurred despite exposing the blood to increased dilution before the haemofilter when compared with the limited dilution which occurred during CVVHDf.

The lifespan of circuits observed during this study can be compared with those observed by other investigators. Similar to this research project Saudan and associates (2006) used the pre-dilution method for both CVVH and CVVHDf. No significant difference in circuit life between each treatment mode was reported but in this comparison, patients were randomised to receive only CVVH or CVVHDf and not the alternative technique. So unlike a crossover study design the comparison of circuit life was limited by not comparing exposure of both treatment modes with the same patient. Another example of how this finding can be compared with other investigations concerns the reported median circuit life of six hours and 35min for pre-dilution CVVH. The result was much shorter than the median lifespan observed by Uchino and associates (2003b) in both the pre-dilution and post-dilution methods of fluid replacement for CVVH (18hrs and 13hrs). Although these two examples are of studies that had different objectives regarding the purpose of the variable under investigation, they do allow a comparison to be made with observations made during this project in the differences in circuit life between CVVH and CVVHDf.

Conceptual Framework Revisited

The possible reasons why a superior circuit life was reported using CVVHDF can be explained using the conceptual framework as discussed in Chapter 3. In this framework physiological and mechanical factors were identified as potential contributors to the deterioration of the filter membrane and the development of blood clots that result in circuit failure. As shown in Figure 3.1 connections with circuit longevity are possible when the conceptual framework is used to identify these factors as both independent and interrelated variables which impact on the longevity of circuit life. By using the framework connections with circuit longevity can for example be made when coagulation activity is identified as a physiological factor or education and machine use is identified as a mechanical factor. Several measures were adopted in the research project to 'isolate' the variable of interest by standardising the research design and hardware and techniques. Differences in the treatment mode alone rather than the method used to perform each technique reduced the known impact of physiological and mechanical factors when comparisons of circuit life were made. Once these variables were controlled, the reason why differences occurred between CVVHDF and CVVH can be explored according to the dependent variable of treatment mode and differences in pre-dilution volume.

Solute Transport and Plasma Water Removal

The advantage in circuit life realised by CVVHDF over CVVH may be explained by the principal method each technique uses to accomplish solute transport and plasma water removal. The rate of solute clearance achieved using CVVHDF is primarily influenced by the concentration gradient in the diffusion of solutes across the semi-permeable membrane. The technique of CVVH relies on hydrostatic pressure applied to the movement of plasma water for solute clearance by convection. On commencement of either treatment the semi-permeable membrane is unsoiled with a similar sieving coefficient of one for both CVVH and CVVHDF. Over the duration of treatment using each technique there is gradual fouling of the membrane influenced in part by the processes of diffusion and convection. This establishes the potential for a relationship between solute transport and plasma water removal with a reduction in membrane efficiency and the possibility of circuit failure by clotting.

A larger volume of plasma water is required to pass through the semi-permeable membrane during CVVH when compared with the alternative technique of CVVHDF in

order to achieve a similar degree of solute clearance. The increased movement of plasma water which occurs during CVVH may result in greater protein adsorption and a reduction in the sieving coefficient of the membrane (Joannidis & Oudemans-Van Straaten, 2007). A theorised illustration portrayed in Figure 6.1 shows how the technique of CVVH facilitates the movement of plasma water and the transport of solutes by convection through the pores of the semi-permeable membrane. The movement of solutes by convection possibly leads to early saturation and occlusion of the membrane pores due to plasma proteins being forced by hydrostatic pressure against the membrane of the blood compartment. On the other hand CVVHDf uses diffusion much more so than convection as the primary mechanism of solute transport. Figure 6.2 is a theorised illustration that demonstrates a reduction in the adherence of plasma proteins to the surface area of the membrane as a result of reduced dependence on hydrostatic pressure for solute transport. In turn this causes a decrease in the movement of plasma water and the force applied to plasma proteins against the membrane surface area of the blood compartment.

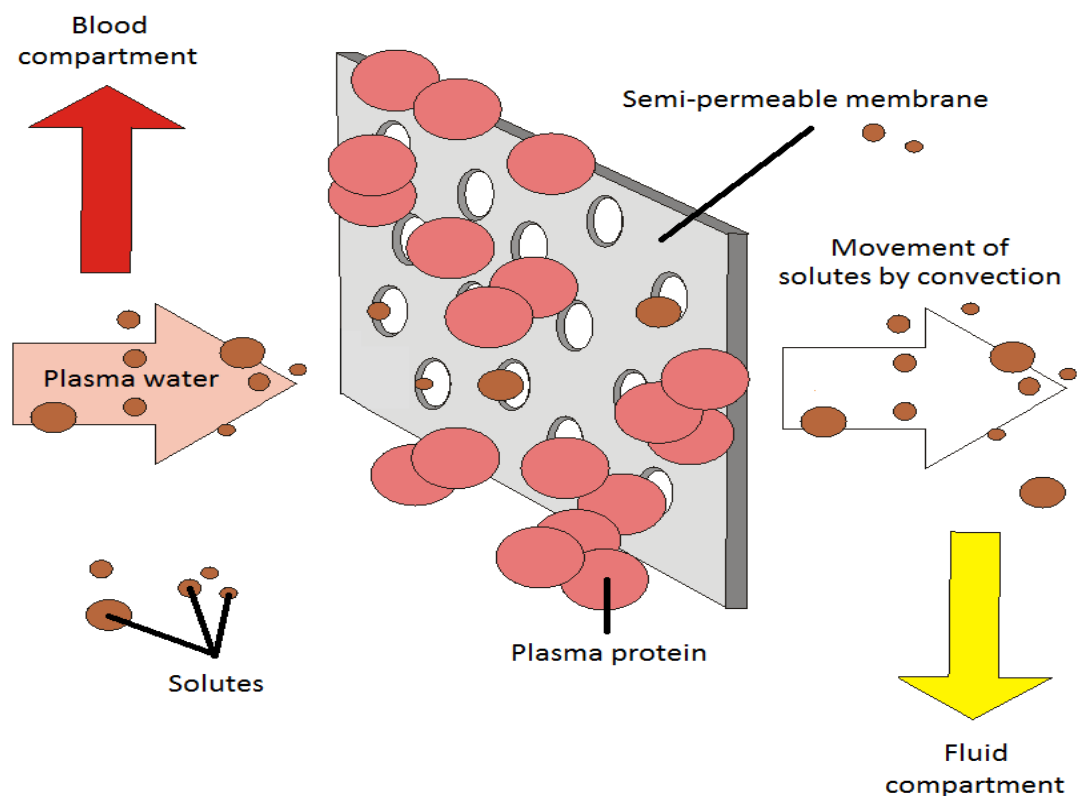

Figure 6.1. An illustration of CVVH using convection to achieve solute clearance shows protein adherence and fouling of the membrane may be increased due to greater reliance on the movement of plasma water

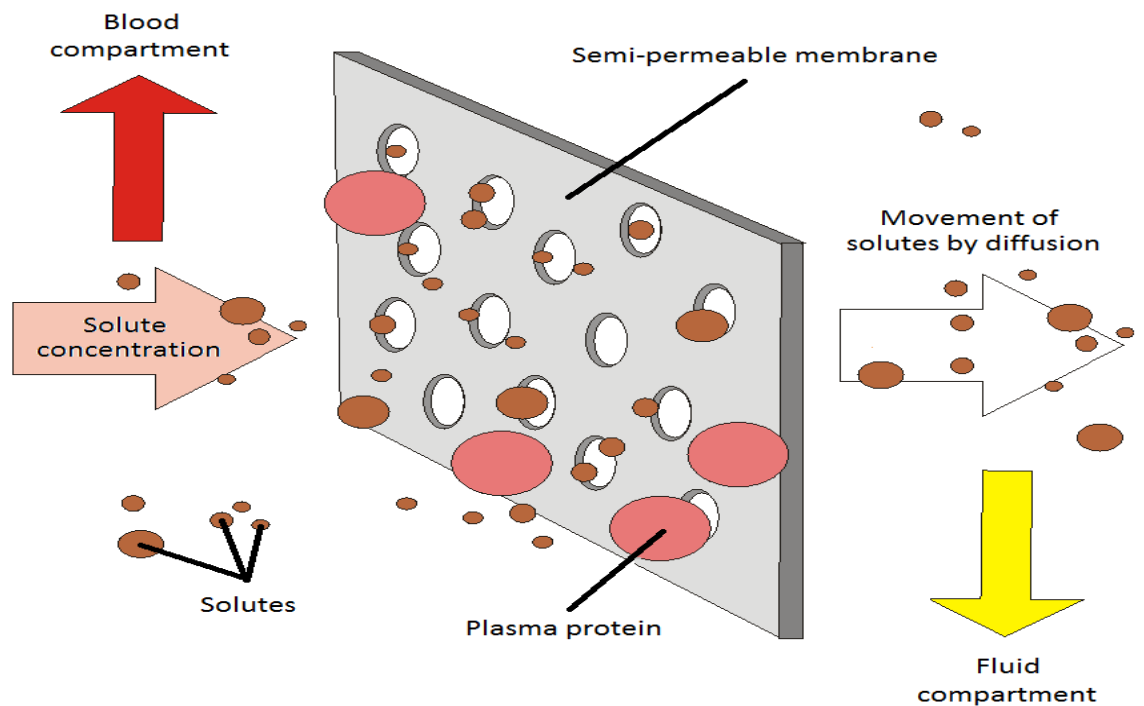

Figure 6.2. An illustration of CVVHDF using primarily diffusion to achieve solute clearance shows protein adherence and fouling of the membrane may be decreased due to less reliance on the movement of plasma water

The escalation of blood-membrane interaction which occurs with the convective more so than the diffusive transport of solutes may not only elevate protein saturation, but can also cause more pronounced activation of the coagulation pathway leading to the premature development of blood clots (Joannidis & Oudemans-Van Straaten, 2007). It is theorised soon after protein adsorption has occurred platelet adhesion appears on the membrane surface area. The adhesion of platelets stimulate the aggregation of platelets and the release of clotting factors which act as triggers for both the contact and tissue factor coagulation pathways (Black, 2008). This theoretical explanation in the activation of both coagulation pathways leads to the formation of thrombin and the generation of fibrin threads and the establishment of a stable clot. The presence of trapped red blood cells along the membrane surface area portrayed in Figure 6.3 encourages the further aggregation of platelets and the formation of larger blood clots, which inevitably leads to obstruction of the haemofilter blood channels and circuit failure. Surface reactions of blood to artificial membranes as theorised to occur during haemodialysis and haemofiltration in the diffusive and convective transport of solutes have been observed using electron microscopic imagery (von Baeyer et al., 1988). Observations of the inner surface area showed a continuous layer of protein molecules

deposited along the membrane when exposed to haemodialysis and haemofiltration. What differed in the study when the same polyacrylonitrile membrane was used for both techniques arose by the limited appearance of fibrin strands rarely visible after application of haemodialysis. This contrasted with a greater prevalence of fibrin strands observed by the authors along the membrane when blood-membrane interaction was associated with the application of haemofiltration.

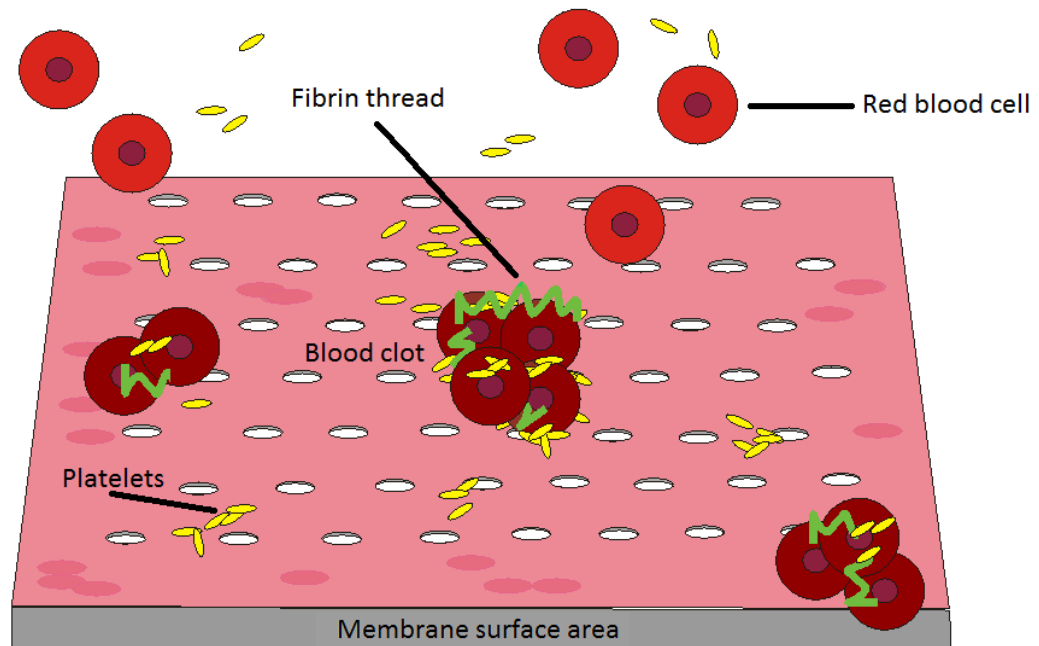

Figure 6.3. An illustration of red blood cells trapped within a fibrin mesh causing the formation of a stable clot and increased aggregation of platelets

The convection-based technique of CVVH has been shown in one study to be associated with elevated transmembrane pressures and premature clotting of the circuit, when compared with the same pressure measurements and incidence of clotting observed using the diffusion only-based technique of CVVHD (Ricci, Ronco, Bachetoni, et al., 2006). A requirement for the higher ultrafiltration volumes associated with CVVH was suggested by the authors as a possible reason why increased transmembrane pressure values were observed, when in comparison the same pressure values were decreased during CVVHD since the majority of solute clearance was instead achieved by dialysis. The elevation of transmembrane pressure and increased procoagulatory activity reported by Ricci and associates (2006) might explain why a similar difference in circuit life was observed between CVVH and CVVHDf, favouring

the diffusion-based technique when the ultrafiltrate volume required for CVVH was substantially reduced using CVVHdf. Although the removal of small and middle-sized molecules was observed by Ricci and associates (2006) to be similar, the authors nevertheless observed a gradual deterioration in solute clearance when using both treatment modes. This supports the premise that the performance of the membrane is decreased as progressive clogging of the membrane occurs and reduces the permeability of the membrane.

Strengths and Weaknesses

The research project had several strengths and weaknesses in the way the study was conducted. Education and training was given special consideration during the conduct of the study as a potential confounding factor if the study protocol was not strictly followed or there was a difference in technical ability in undertaking either mode of CRRT. The strengths and weaknesses of the project are accounted for through the study design and application of each technique.

Study Design

The investigation was limited to a single study site using a sample of patients whose characteristics were nevertheless consistent with those most likely to require CRRT. Over half of the patients randomised to receive CVVH or CVVHdf were admitted to ICU for medical reasons (67%), with the remainder of patients admitted after surgery (33%). A similar distribution of medical and surgical patients with ARF requiring RRT was reported during a world-wide survey (Uchino, et al., 2005). By using a sample of patients which included numerous physical disorders the comparison of circuit life between CVVH and CVVHdf represented a response that could be generalised to include a broad range of critically ill patients.

The investigation featured a study design that aimed to limit the effect of bias and uncontrolled variables in participant and mode selection. A randomised comparative crossover study design was used which successfully controlled for a variety of physiological and mechanical factors identified in the conceptual framework. The approach sought to minimise the influence each of the confounding variables associated with an individual patient such as severity of illness and coagulation status by using the patient as their own control. It also controlled for operator bias by predetermining the sequence of mode to be delivered to the participant at trial enrolment.

The number of enrolled participants met the pre-determined sample size estimate as outlined in the Methods chapter. This calculation was based upon a clinically significant difference in circuit life being 4 hours, with α set at 0.05 and β at 0.80, both of which are widely accepted statistical limits. Only circuits where a successful crossover had occurred in patients exposed to both CVVH and CVVHDF were included in the investigation and starting mode selection was randomised across the sample. The average mean difference observed when using CVVHDF exceeded the required effect of 4 hours and a 95% CI. Based on these findings there is reasonable evidence to suggest variations in circuit life ‘captured’ during the investigation are plausible and reflect a ‘true’ difference in circuit life between CVVH and CVVHDF.

The physiological factor severity of illness was also controlled for by using a within participant crossover design. Each patient was assigned an initial treatment mode through randomisation and the change in sequence of mode reduced the degree of influence the disease process may have impacted on circuit life. At the start of each crossover no treatment mode was observed to have been repeatedly selected with the opposite sequence of crossovers almost occurring with the same level of frequency, as would be expected through the randomisation process.

In addition to reducing the possible effects of circuit sequencing and physiological differences among patients, the study also placed control on how CVVH and CVVHDF was delivered to the patient. The control placed on confounding variables was applied to mechanical factors identified in the conceptual framework. Using the same hardware (Hygieia ‘Plus’TM CRRT machine) blood was pumped at 200ml per min through the same type of vascular access catheter (GamCatheterTM or Arrow-HowesTM or NiagaraTM or CookTM) and venous access site for both modes of CRRT. The decision to ‘standardise’ both techniques strengthened as much as possible the operational approach of the study (no control was placed on the site chosen for the insertion of the vascular access catheter which was determined by clinical judgement of the attending medical officer). This allowed the separation of differences in pre-dilution volume (the variable of interest) from mechanical factors confounding the comparison of circuit life between CVVH and CVVHDF.

The comparison of circuit life between CVVH and CVVHDF was aided by using the same haemofilter (Nephral 300ST) for both treatment modes. In this way, on commencement of each technique, the membrane common to both CVVH and

CVVHdf circuits caused a similar haemostatic reaction. It is known differences in the biocompatibility of the membrane can influence the degree of blood-membrane interaction and the extent of haemostatic activation which occurs when blood is exposed to non-biological surfaces (Pascual, Swinford, & Tolckoff-Rubin, 1997). By choosing the same material and membrane surface area to facilitate convection and diffusion the issue of biocompatibility identified as a physiological factor in the conceptual framework was controlled. The approach effectively met the diffusive requirements of CVVHdf and the convective requirements of CVVH, whilst standardising the exposure of blood to a foreign surface membrane area thereby controlling for the potential confounding physiological factor of biocompatibility.

The passage of plasma water through the membrane is of particular importance during CVVH and requires a surface area large enough to achieve adequate clearance since the technique is more reliant than CVVHdf on convection for solute removal. The selection of membranes which provide a larger surface area to facilitate solute removal have the potential to reduce the resistance of blood flow through the haemofilter and may offer the possibility of promoting circuit life by decreasing procoagulatory activity (Baldwin, 2007). Using a larger surface area within the haemofilter may influence the rate at which the membrane is exposed to protein layering and the amount of saturation tolerated by the membrane. The integrity of the haemofilter is then possibly sustained for longer by the larger surface area. Studies which have demonstrated the successful application of CVVH show the surface area of the membrane selected by investigators can vary considerably. A surface area of 0.7m² and 1.3m² was used by Ronco and associates (2000) when investigating the influence of haemofiltration dose on patient outcomes. The use of CVVH has also been reported with the haemofilter having a larger surface area of 1.4m² and 1.6m² (Chung et al., 2008; Monchi, et al., 2004). Based on the experiences of other investigators the decision to select a surface area of 1.3m² was considered sufficient to accommodate the convective capacity of CVVH.

Another strength in the study design addressed the physiological factor of coagulation activity as shown in the conceptual framework by the application of an identical anticoagulation regimen for both techniques. The same concentration of heparin 10,000IU diluted in 50ml; of 5% Dextrose delivered at the same circuit location to achieve a target systemic aPTT of 40 to 55s was used. Other studies have targeted a similar aPTT (Nagarik, et al., 2010; van de Wetering, et al., 1996) or a higher range of values (Reeves, et al., 1999) when monitoring the response of heparin to achieve

anticoagulation of the circuit. Patients who were unsuitable for heparin anticoagulation were excluded from study enrolment ensuring a consistent approach to circuit anticoagulation throughout the project.

A weakness of the study design was where variability in the *dose* of haemodialysis and haemofiltration delivered to the patient was allowed to occur which could potentially confound the comparison of circuit life between CVVH and CVVHDF. Using a hypothetical case of a 70kg and 100kg patient the contrast in dose delivery and effluent volume can be demonstrated. As shown in Table 6.1, the required effluent flow rate to achieve 35ml per kg per hr for CVVH equated to 2,450ml in a 70kg patient. In contrast, the CVVHDF dose when fixed irrespective of patient weight required an effluent volume of 1,600ml. This discrepancy in dose between the different treatment modes was further increased when the comparison was conducted on a 100kg patient as shown in Table 6.2. The difference in effluent volume can be explained as a result of the replacement fluid being routinely set at 600ml per hr and the dialysis dose for CVVHDF being prescribed at 1,000ml per hr despite the capacity in the study design to vary the volume from 500ml to 2,000ml per hr. The ultrafiltration dose for CVVH was on the other hand determined by the patient's weight and the volume of effluent required influenced by the body size of the patient. As a consequence of these differences the haemodialysis or haemofiltration *dose* between both techniques varied, with CVVH disadvantaged by the potential of increased procoagulatory activity when CVVHDF was not required to match a similar treatment dose.

Table 6.1

Variability of dose delivery using the example of a 70kg patient in effluent volume required for CVVH and CVVHDF

Treatment Mode	Effluent Volume	Dose
CVVH	$35 \times 70 \times 1 = 2,450\text{ml}^{\text{a}}$ (plus fluid balance requirements)	35ml per kg per hr
CVVHDF	$1000^{\text{b}} + 600^{\text{a}} = 1,600\text{ml}$ (plus fluid balance requirements)	22ml per kg per hr

a. Pre-dilution replacement fluid

b. Dialysate

Table 6.2

Variability of dose delivery using the example of a 100kg patient in effluent volume required for CVVH and CVVHDF

Treatment Mode	Effluent Volume	Dose
CVVH	$35 \times 100 \times 1 = 3,500\text{ml}^{\text{a}}$ (plus fluid balance requirements)	35ml per kg per hr
CVVHDF	$1000^{\text{b}} + 600^{\text{a}} = 1,600\text{ml}$ (plus fluid balance requirements)	16ml per kg per hr

a. Pre-dilution replacement fluid

b. Dialysate

It is unlikely that patients on this study received a *dose* which was under the treatment threshold where no beneficial effect was received and during the investigation the prescribed *dose* reflected widespread clinical practice used in support of renal function. When the study was conceived the *dose* debate was in its infancy and the importance of adjusting for body weight had not received much attention by clinicians. It was only after the study had been completed did the issue of dose become clearer and influence changes at the bedside.

Another weakness of the study design allowed the variable of interest to be unblinded and the possibility for bias to occur when CVVHDf was seen to extend circuit life more than CVVH. The impact of human behaviour may have influenced the results observed and produced the phenomena referred to as the ‘Hawthorne’ effect (Parsons, 1974). Although guidelines on what constituted a natural circuit life were defined (observations showing the appearance of blood clots against TMP > 200mmHg and P-venous > 150mmHg) the method used was open to interpretation with some circuits possibly being terminated earlier than would otherwise be the case had a more stringent criteria been applied. In operating the circuit to deliver CVVHDf the nurse performing the task may have had a more positive attitude to the technique and reacted differently to events during the lifespan of the circuit, compared with a more negative response to the prospect of shorter circuit life when CVVH was assigned to the patient. On reflection the study design may have caused a Hawthorne effect to occur but the nature of the investigation made attempts at blinding the study impracticable and unavoidable since awareness of treatment mode was necessary to perform both techniques safely.

Education and Training

The limited exposure of CVVH at the study site could have influenced circuit life when comparisons were made with measurements obtained by nurses only familiar with CVVHDf. A survey undertaken in Canada investigating the provision of CRRT training found limited exposure of staff to patients requiring CRRT increased the difficulty of maintaining competency in performing the technique (Langford, et al., 2008). Ongoing evaluation of clinical practice in the application of the technique is also considered essential and when not addressed adequately can be an important factor affecting the lifespan of the circuit (Baldwin, 2007). In an effort to address this issue a training programme to minimise the mechanical factor of technical inexperience as a variable possibly impacting on circuit longevity was introduced prior to and during the study. All nurses allocated to patients who were participating in the study had received

sufficient training and recent experience to proficiently operate the Hygieia 'Plus'TM CRRT machine and understood the requirements of CVVHdf. The ability to manage an alarm event and minimise interruptions due to stoppages in blood flow was included as part of the training programme and a requirement for this competency to be demonstrated. Variations in the operating procedures for CVVH were addressed separately by the provision of additional training and supervision to extend the knowledge of nursing staff already familiar with CVVHdf. Although circuit configuration and settings required were different for each mode, the semi-automated nature of the Hygieia 'Plus'TM CRRT machine also reduced the potential for operator error once the machine was activated. Ultimately, if experience using CVVH had been a confounding mechanical factor it might be expected to see a consistent improvement in CVVH circuit life over the length of the study as expertise was gained. Instead the shortened lifespan of CVVH was observed throughout the duration of the study occasionally interspersed by the survival of some circuits which were comparable with CVVHdf.

Summary

The research project successfully compared circuit life using the techniques of CVVH and CVVHdf according to the available technology and in the protocols followed at the study site. No other published study has reported the use of a randomised crossover study design to investigate differences using the pre-dilution method of fluid replacement in circuit life between CVVH and CVVHdf. Organisation of the investigation around a conceptual framework provided one way to accommodate physiological and mechanical factors known to influence the longevity of circuit life. By making reference to these factors as possible confounding variables their potential impact on circuit life was controlled for during the investigation. The randomised crossover study design exposed the same patient to both treatment modes limiting the impact of physiological differences in the severity of illness affecting the comparison of circuit life. Attention to operator competency in using both treatment modes also reduced the possibility of mechanical factors confounding circuit life comparisons, when the same education and training was given on how to operate both techniques minimised the potential for operational errors to influence circuit longevity. Each example given demonstrates how control was achieved on several physiological and mechanical factors which strengthen the reliability that technique alone was responsible for differences in circuit life observed during the comparison between CVVH and

CVVHDf. At the time of the investigation the findings of this research project supported the continued use of CVVHDf and not CVVH given the hardware and procedures followed at the study site. In choosing CVVHDf the opportunity to maximise treatment delivery and reach the desired level of dose intensity is possibly realised more easily than CVVH by the improvement of circuit life maintaining the continuous nature of the technique.

CHAPTER 7

CONCLUSIONS & RECOMMENDATIONS

This thesis reports the findings of a randomised crossover study which investigated the affect on circuit life of varying pre-dilution volumes associated with CVVH and CVVHDF. These findings suggest that for CRRT in the adult ICU patient, the lower pre-dilution volume and diffusive clearance required for CVVHDF will provide a longer functional circuit life. This was in contrast to CVVH which produced shorter circuit when higher pre-dilution volumes were required to achieve clearance by convection. The evaluation of treatment efficiency in terms of circuit life between the two different techniques is of clinical importance, since each treatment mode depends upon a measure of circuit longevity to achieve adequate replacement of renal function.

Concluding Comments

Taking into account the various study design factors, the findings from the study suggest circuit life is influenced by the choice of CRRT mode. The technique of prediluted CVVHDF as a diffusion-based treatment mode appears to have a protective effect on membrane interactivity. The transfer of solutes is predominantly a passive process across the semi-permeable membrane and as a result of less haemostatic activation the onset of clotting is delayed. The alternative technique of prediluted CVVH is a convection-based treatment mode which depends on plasma water removal in the transfer of solutes through the semi-permeable membrane. Whilst pre-dilution avoids haemoconcentration within the haemofilter fibres to some extent, it is theorised that an intensification of membrane interactivity occurs which exposes the CVVH circuit to greater haemostatic activation and changes in blood viscosity that is not compensated by the larger volumes of replacement fluid associated with the technique. The reduced circuit down-time observed with CVVHDF in the study may lead to more effective delivery of CRRT due to the increase of circuit life associated with this diffusion-based treatment mode.

The study has several limitations which should be considered when evaluating the finding of differences in circuit life between the two treatment modes. The nature of the intervention made it impossible to blind this type of study and there was a potential for bias to occur if CVVH or CVVHDF was observed to bring about longer circuit life

compared with the alternative technique. As a single-centre study which tightly controlled technical aspects of both modes of therapy, it is unknown if similar results would be obtained using different anticoagulation regimens or venous access catheters or machine hardware. In comparing circuit life using CVVH and CVVHDF the dose delivered to the patient and the effluent volume required were not the same for both treatment modes.

Recommendations for Future Research

A cautious approach should be exercised when making recommendations based on the findings of this study. Short circuit life for many critically ill patients on CRRT is a problem which requires more examination. The choice of treatment mode as a strategy to increase the lifespan of the extracorporeal circuit and maximise the beneficial effects of CRRT is one example where additional research is required. Several recommendations based on the findings of this study are suggested for where further research might follow. The recommendations include proposals to substantiate the reported increase of circuit lifespan during CVVHDF and the investigation of other strategies which have the potential to maximise treatment delivery:

- A repeat of the study using the lower dose of 25ml per kg per hr for CVVH would reduce the passage of plasma water required across the membrane when the same volume of effluent to be exchanged was used to compare circuit life with CVVHDF. Implementation of the lower dose proposed for this study would allow renal support to be above the minimum intensity required but provide a 'buffer' against the possibility of a delay in treatment continuity caused by the time taken for a new circuit to be made ready. Likewise the CVVHDF dose should be set at the same level and dialysate volume varied to achieve the desired dose.
- Further attempts made at repetition of the study should include the analysis of TMP values following the reported correlation of shorter circuit life with higher pressure readings (Ricci, Ronco, Bachetoni, et al., 2006). The decision to discontinue the circuit would continue to require visual inspection of the haemofilter, but evidence of clotting supported by TMP measurements indicating a natural circuit life had been reached could add further to how circuits are managed clinically and diagnosis of true circuit life.

- After the study was completed in 2006 the purchase of new CRRT machines at the study site offers technological improvements which allow the operator to adjust the volume of replacement fluid which can be split between the pre-dilution and post-dilution methods of fluid delivery. A more balanced approach may now be possible using these new machines during convective therapies like CVVH for reducing excessive haemoconcentration within the haemofilter but limiting the degree of dilution reducing the intensity of solute clearance. Following the abandonment of the 100% pre-dilution or post-dilution approach to replacement fluid delivery, the possibility of using an equal split between each method adds another area of interest which requires further investigation.
- A method of recording and displaying information acquired from CRRT circuits is recommended to be implemented for improving assessment of circuit function. The use of CRRT machines like the Hygieia 'Plus'TM used in the study provide real-time digital output of parameters, alarms and events that occur during treatment, but currently information remains under utilised by the bedside nurse due to lack of appropriate data capture and analysis software. Circuit pressure monitoring technology may provide the opportunity to improve the performance of CRRT by the graphical display in real-time of specific events which occur during the lifespan of each circuit. Understanding aspects of events which cause circuit failure, such as patient repositioning interrupting blood flow or changes in procoagulatory activity leading to premature clotting, are worth investigating to minimise the affect each may have in the delivery of treatment or during the evaluation of interventional studies. The information obtained has the potential to be used by the bedside nurse to minimise unexpected circuit failure by allowing appropriate action to be undertaken according to physiological factors associated with the patient, or the result of mechanical factors such as equipment malfunction. Alternatively the capture of information on circuit function may be archived and pressure trends reviewed for teaching purposes, or used in the development of protocols to direct areas of practice which match pressure profiles associated with natural circuit life.

- The study should be repeated again as a multi-centre investigation with the enrolment of larger patient numbers using assorted hardware to compare differences in circuit life between CVVH and CVVHDf. The possibility of operational variations might arise when both techniques are performed by more than one ICU and will require the development of standardised protocols for both CVVH and CVVHDf across each of the study sites.
- The decision to repeat the study again may instead involve the investigation based on comparisons using alternative circuit anticoagulation regimens. The emergence of citrate as a regional anticoagulant with CRRT is one example which could be applied to CVVH and CVVHDf. The use of citrate to anticoagulate the circuit can be performed using both techniques by the pre-dilution method of fluid replacement.
- The degree of interaction which occurs when blood comes into contact with the surface area of the membrane during convective versus diffusive mechanisms of solute removal should be investigated using electron microscopic imagery. A scoring system similar to the one used by Hofbauer and associates (1999) to measure the effect of different anticoagulation regimens on blood membrane interactions can provide a quantitative means to describe the degree of membrane haemostatic activity between CVVH and CVVHDf. The clotting score includes a description of thrombosis formation, evidence of fibrin threads, the level of platelet aggregation, the accumulation of trapped red blood cells, and the extent of occlusion in the fibre lumen. After each treatment was completed on the same patient the CVVH and CVVHDf circuits would be taken down and the haemofilter saved for electron microscopy analysis. The procedure would require the dissection of each haemofilter to expose individual fibres and the surface of the membrane. Once imagery of the membrane surface area was completed the morphology of thrombosis formation during CVVH and CVVHDf can compare haemostatic activity according to the clotting scoring system.

REFERENCES

- Abbenbroek, B., Baldwin, I., Boyle, M., Foster, M., Hunt, T., Leslie, G. D., et al. (2004). Nursing Guidelines for the use of Xigris (drotrecogin alfa [activated] rhu). Printed by Lilly.
- Abernethy, V. E., & Lieberthal, W. (2002). Acute renal failure in the critically ill patient. *Critical Care Clinics*, *18*, 203-222.
- Abosaif, N. Y., Tolba, Y. A., Heap, M., Russell, J., & Nahas, A. M. (2005). The outcome of acute renal failure in the intensive care unit according to RIFLE: Model application, sensitivity, and predictability. *American Journal of Kidney Diseases*, *46*(6), 1038-1048.
- Abramson, S., & Niles, J. L. (1999). Anticoagulation in continuous renal replacement therapy. *Current Opinion in Nephrology and Hypertension*, *8*, 701-707.
- Abuclo, J., Shemin, D., & Chazan, J. (1993). Acute symptoms produced by haemodialysis: A review of their causes and associations. *Seminars in Dialysis*, *6*, 59-69.
- Abuelo, J. G. (2007). Normotensive Ischemic Acute Renal Failure Current Concepts. *The New England Journal of Medicine*, *357*(8), 797-805.
- AcuteRenalFailureTrialNetwork. (2008). Intensity of Renal Support in Critically Ill Patients with Acute Kidney Injury. *The New England Journal of Medicine*, *359*(1), 7-20.
- Adroge, H. J., & Madias, N. E. (2000). Hyponatremia. *New England Journal of Medicine*, *342*(21), 1581-1589.
- Ahern-Gould, K., & Stark, J. (1998). Quick resource for electrolyte imbalance. *Critical Care Nursing Clinics of North America*, *10*(4), 477-490.
- Alonso, A., Lau, J., Jaber, B. L., Weintraub, A., & Sarnak, M. J. (2004). Prevention of Radiocontrast Nephropathy With N-Acetylcysteine in Patients With Chronic Kidney Disease: A Meta-Analysis of Randomised, Controlled Trials. *American Journal of Kidney Diseases*, *43*(1), 1-9.
- Alper Jr., A. B., Shenava, R. G., & Young, B. A. (2010). <http://emedicine.medscape.com/article/245296-overview>. Retrieved 23rd March 2010
- Altman, D. (1991). *Practical Statistics for Medical Research*. London: Chapman & Hall.
- Annane, D., Vignon, P., Renault, A., Ballaert, P.-E., Charpentier, C., Martin, C., et al. (2007). Norepinephrine plus dobutamine versus epinephrine alone for management of septic shock: a randomised trial. *Lancet*, *370*, 676-684.

- Antoun, T. A., & Palevsky, P. M. (2009). Selection of Modality of Renal Replacement Therapy. *Seminars in Dialysis*, 22(2), 108-113.
- Atherikul, K., Schwab, S. J., & Conlon, P. J. (1998). Adequacy of haemodialysis with cuffed central-vein catheters. *Nephrology Dialysis Transplantation*, 13, 745-749.
- Aucella, F., Paolo, S. D., & Gesualdo, L. (2007). Dialysate and Replacement Fluid Composition for CRRT. *Contributions to Nephrology*, 156, 287-296.
- Augustine, J. J., Sandy, D., Seifert, T. H., & Paganini, E. P. (2004). A randomized controlled trial comparing intermittent with continuous dialysis in patients with ARF. *American Journal of Kidney Diseases*, 44(6), 1000-1007.
- Bader, B. D., Berger, E. D., Heede, M. B., Silberbauer, I., Duda, S., Risler, T., et al. (2004). What is the best hydration regimen to prevent contrast media-induced nephrotoxicity? *Clinical Nephrology*, 62(1), 1-7.
- Baglin, T., Barrowcliffe, T. W., Cohen, A., & Greaves, M. (2006). Guidelines on the use and monitoring of heparin. *British Journal of Haematology*, 133, 19-34.
- Bagshaw, S. M., Bellomo, R., & Kellum, J. A. (2008). Oliguria, volume overload, and loop diuretics. *Critical Care Medicine*, 36(Suppl 4), S172-S178.
- Bagshaw, S. M., Berthiaume, L. R., Delaney, A., & Bellomo, R. (2008). Continuous versus intermittent renal replacement therapy for critically ill patients with acute kidney injury: A meta-analysis. *Critical Care Medicine*, 36(2), 610-617.
- Bagshaw, S. M., Delaney, A., Haase, M., Ghali, W. A., & Bellomo, R. (2007). Loop diuretics in the management of acute renal failure: A systematic review and meta-analysis. *Critical Care and Resuscitation*, 9(1), 60-68.
- Bagshaw, S. M., George, C., & Bellomo, R. (2007). Changes in the incidence and outcome for early acute kidney injury in a cohort of Australian intensive care units. *Critical Care*, 11(3), R68-R76.
- Bagshaw, S. M., Laupland, K. B., Boiteau, P. J. E., & Godinez-Luna, T. (2005). Is regional citrate superior to systemic heparin anticoagulation for continuous renal replacement therapy? A prospective observational study in an adult regional critical care system. *Journal of Critical Care*, 20(2), 155-161.
- Bagshaw, S. M., Laupland, K. B., Doig, C. J., Mortis, G., Fick, G. H., Mucenski, M., et al. (2005). Prognosis for long-term survival and renal recovery in critically ill patients with severe acute renal failure: A population-based study. *Critical Care*, 9(6), R700-R7009.
- Bagshaw, S. M., Uchino, S., Bellomo, R., Morimatsu, H., Morgera, S., Schetz, M., et al. (2007). Beginning and Ending Supportive Therapy for the Kidney (B.E.S.T. Kidney) Investigators. Septic Acute Kidney Injury in Critically Ill Patients: Clinical Characteristics and Outcomes. *Clinical Journal of the American Society of Nephrology*, 2, 431-439.
- Bagshaw, S. M., Uchino, S., Bellomo, R., Morimatsu, H., Morgera, S., Schetz, M., et al. (2009). Timing of renal replacement therapy and clinical outcomes in critically

- ill patients with severe acute kidney injury. *Journal of Critical Care*, 24, 129-140.
- Baldwin, I. (1997). Training, management, and credentialing for CRRT in the ICU. *American Journal of Kidney Diseases*, 30(5 Suppl. 4), S112-S116.
- Baldwin, I. (2007). Factors Affecting Circuit Patency and Filter 'Life'. *Contributions to Nephrology*, 156, 178-184.
- Baldwin, I., & Bellomo, R. (2004). Relationship between Blood Flow, Access Catheter and Circuit Failure during CRRT: A Practical Review. *Contributions to Nephrology*, 144, 203-213.
- Baldwin, I., Bellomo, R., & Koch, B. (2004). Blood flow reductions during continuous renal replacement therapy and circuit life. *Intensive Care Medicine*, 30(11), 2074-2079.
- Baldwin, I., Bridge, N., & Elderkin, T. (1998). Nursing issues, practices, and perspectives for the management of continuous renal replacement therapy in the intensive care unit. In C. Ronco & R. Bellomo (Eds.), *Critical Care Nephrology* (1st ed., pp. 1309-1325). Dordrecht: Kluwer Academic Publishers.
- Baldwin, I., Naka, T., Koch, B., Fealy, N., & Bellomo, R. (2007). A pilot randomised controlled comparison of continuous veno-venous haemofiltration and extended daily dialysis with filtration: Effect on small solutes and acid-base balance. *Intensive Care Medicine*, 33, 830-835.
- Baldwin, I., Tan, H. K., Bridge, N., & Bellomo, R. (2000). A prospective study of thromboelastography (TEG) and filter life during continuous veno-venous hemofiltration. *Renal Failure*, 22(3), 297-306.
- Baldwin, I., Tan, H. K., Bridge, N., & Bellomo, R. (2002). Possible strategies to prolong circuit life during hemofiltration: Three controlled studies. *Renal Failure*, 24(6), 839-848.
- Balk, R. A. (2000). Severe sepsis and septic shock: Definitions, epidemiology and clinical manifestations. *Critical Care Clinics*, 16(2), 179-192.
- Barenbrock, M., Hausberg, M., Matzkies, F., de la Motte, S., & Schaefer, R. M. (2000). Effects of bicarbonate- and lactate-buffered replacement fluids on cardiovascular outcome in CVVH patients. *Kidney International*, 58, 1751-1757.
- Begg, C., Cho, M., Eastwood, S., Horton, R., Moher, D., Olkin, I., et al. (1996). Improving the Quality of Reporting of Randomized Controlled Trials: The CONSORT Statement. *Journal of American Medical Association*, 276(8), 637-639.
- Bell, M., Granath, F., Schon, S., Ekblom, A., & Claes-Roland, M. (2007). Continuous renal replacement therapy is associated with less chronic renal failure than intermittent haemodialysis after acute renal failure. *Intensive Care Medicine*, 33, 773-780.
- Bell, M., Liljestam, E., Granath, F., Fryckstedt, J., Ekblom, A., & Martling, C.-R. (2005). Optimal follow-up time after continuous renal replacement therapy in

- actual renal failure patients stratified with the RIFLE criteria. *Nephrology Dialysis Transplantation*, 20, 354-360.
- Beller, E. M., GebSKI, V., & Keech, A. C. (2002). Randomisation in clinical trials. *Medical Journal of Australia*, 177, 565-567.
- Bellomo, R. (1996). Choosing a therapeutic modality: hemofiltration versus hemodialysis versus hemodiafiltration. *Seminars in Dialysis*, 9(2), 88-92.
- Bellomo, R. (2006). The epidemiology of acute renal failure: 1975 versus 2005. *Current Opinion in Critical Care*, 12, 557-560.
- Bellomo, R., Champman, M., Finfer, S., Hickling, K., & Myburgh, J. (2000). Low-dose dopamine in patients with early renal dysfunction: a placebo-controlled randomised trial. Australian and New Zealand Intensive Care Society (ANZICS) Clinical Trials Group. *Lancet*, 356, 2139-2143.
- Bellomo, R., Farmer, M., Wright, C., Parkin, G., & Boyce, N. (1995). Treatment of sepsis-associated severe acute renal failure with continuous hemodiafiltration: Clinical experience and comparison with conventional dialysis. *Blood Purification*, 13, 246-254.
- Bellomo, R., Mansfield, D., Rumble, S., Shapiro, J., Parkin, G., & Boyce, N. (1992). Acute renal failure in critical illness: Conventional dialysis versus acute continuous hemodiafiltration. *American Society of Artificial Internal Organs Journal*, 38, M654-M657.
- Bellomo, R., Parkin, G., Love, J., & Boyce, N. (1993). A Prospective Comparative Study of Continuous Arteriovenous Hemodiafiltration and Continuous Venovenous Hemodiafiltration in Critically Ill Patients. *American Journal of Kidney Diseases*, 21(4), 400-404.
- Bellomo, R., & Ronco, C. (1999). Renal replacement therapy in the intensive care unit. *Critical Care and Resuscitation*, 1, 13-24.
- Bellomo, R., & Ronco, C. (2000). Continuous haemofiltration in the intensive care unit. [Review]. *Critical Care*, 4(6), 339-345.
- Bellomo, R., & Ronco, C. (2002a). Anticoagulation during CRRT. In R. Bellomo, I. Baldwin, C. Ronco & T. Golper (Eds.), *Atlas of Haemofiltration* (pp. 63-68). Sydney: W. B. Saunders.
- Bellomo, R., & Ronco, C. (2002b). An Introduction to Continuous Renal Replacement Therapy. In R. Bellomo, I. Baldwin, C. Ronco & T. Golper (Eds.), *Atlas of Haemofiltration* (pp. 1-9). Sydney: W. B. Saunders.
- Bellomo, R., & Ronco, C. (2002c). Vascular access for continuous renal replacement therapy. In R. Bellomo, I. Baldwin, C. Ronco & T. Golper (Eds.), *Atlas of Haemofiltration* (pp. 77-82). Sydney: W.B. Saunders.
- Bellomo, R., Ronco, C., Kellum, J. A., Mehta, R. L., & Palevsky, P. M. (2004). Acute renal failure - definition, outcomes measures, animal models, fluid therapy and information technology needs: The second international consensus conference of

the Acute Dialysis Quality Initiative (ADQI) group. *Critical Care*, 8(4), R204-R212.

- Bellomo, R., Teede, H., & Boyce, N. (1993). Anticoagulant regimens in acute continuous hemodiafiltration. *Intensive Care Medicine*, 19, 329-332.
- Bellomo, R., Tipping, P., & Boyce, N. (1993). Continuous veno-venous hemofiltration with dialysis removes cytokines from the circulation of septic patients. *Critical Care Medicine*, 21(4), 522-526.
- Bellomo, R., Wan, L., & May, C. (2008). Vasoactive drugs and acute kidney injury. *Critical Care Medicine*, 36(Suppl. 4), S179-186.
- Berbec, A. N., & Richardson, R. M. A. (2006). Sustained low-efficiency dialysis in the ICU: Cost, anticoagulation and solute removal. *Kidney International*, 70(5), 963-968.
- Bernard, G. R., Vincent, J. L., Laterre, P. F., LaRosa, S. P., Dhainaut, J. F., Lopez-Rodriguez, A., et al. (2001). Efficacy and safety of recombinant human activated protein C for severe sepsis. *The New England Journal of Medicine*, 344(10), 699-709.
- Bersten, A. D., & Holt, A. W. (1995). Vasoactive Drugs and the Importance of Renal Perfusion Pressure. *New Horizons*, 3(4), 650-661.
- Betjes, M. G. H., Oosterom, M. V. A., & Wetering, J. (2007). Regional citrate versus heparin anticoagulation during venovenous hemofiltration in patients at low risk for bleeding: similar hemofilter survival but significantly less bleeding. *Journal of Nephrology*, 20(5), 602-608.
- Birck, R., Krzossok, S., Markowetz, F., Schnulle, P., van der Woude, F. J., & Braun, C. (2003). Acetylcysteine for prevention of contrast nephropathy: meta-analysis. *Lancet*, 362, 598-603.
- Black, K. (2008). Anticoagulation for Haemodialysis. *Renal Society of Australasia Journal*, 4(2), 95-98.
- Boldt, J., Menges, T., Wollbruck, M., Sonnerborn, S., & Hempelmann, G. (1994). Continuous hemofiltration and platelet function in critically ill patients. *Critical Care Medicine*, 22(7), 1155-1160.
- Bonventre, J. V., & Weinberg, J. M. (2003). Recent Advances in the Pathophysiology of ischemic Acute Renal Failure. *Journal of American Society of Nephrology*, 14, 2199-2210.
- Bosch, X., Poch, E., & Grau, J. M. (2009). Rhabdomyolysis and Acute Kidney Injury. *New England Journal of Medicine*, 361, 62-72.
- Bouchard, J., Soroko, S. B., Chertow, G. M., Himmelfarb, J., Ikizler, T. A., Paganini, E. P., et al. (2009). Fluid accumulation, survival and recovery of kidney function in critically ill patients with acute kidney injury. *Kidney International*, 76, 422-427.

- Bouman, C. S. C., Oudemans-Van Straaten, H. M., Tijssen, J. G. P., Zandstra, D. F., & Kesecioglu, J. (2002). Effects of early high-volume continuous venovenous hemofiltration on survival and recovery of renal function in intensive care patients with acute renal failure: A prospective, randomized trial. *Critical Care Medicine*, 30(10), 2205-2211.
- Boyle, M., & Baldwin, I. (2010). Understanding the Continuous Renal Replacement Therapy Circuit for Acute Renal Failure Support. *AACN Advanced Critical Care*, 21(4), 367-375.
- Brezis, M., & Rosen, S. (1995). Hypoxia of the renal medulla: Its implications for disease. *New England Journal of Medicine*, 332(10), 647-655.
- Brivet, G., Kleinknecht, D., Loirat, P., & Landais, P. (1996). Acute renal failure in intensive care units: causes, outcome, and prognostic features of hospital mortality: a prospective, multicentre study. French study group on acute renal failure. *Critical Care Medicine*, 24(2), 192-198.
- Brooks, G. (2006). Potassium additive algorithm for use in continuous renal replacement therapy. *Nursing in Critical Care*, 11(6), 273-280.
- Brophy, P. D., Somers, M. J., Baum, M. A., Symons, J. M., McAfee, N., Fortenberry, J. D., et al. (2005). Multi-centre evaluation of anticoagulation in patients receiving continuous renal replacement therapy (CRRT). *Nephrology Dialysis Transplantation*, 20(7), 1416-1421.
- Brower, R. G. (2009). Consequences of bed rest. *Critical Care Medicine*, 37(Suppl 10), S422-S428.
- Bugge, J. F. (2004). Influence of renal replacement therapy on pharmacokinetics in critically ill patients. *Best Practice & Research Clinical Anaesthesiology*, 18(1), 175-187.
- Canaud, B., Desmeules, S., Klouche, K., Leray-Moragues, H., & Beraud, J. J. (2004). Vascular access for dialysis in the intensive care unit. *Best Practice & Research Clinical Anaesthesiology*, 18(1), 159-174.
- Canaud, B., Leray-Moragues, H., Leblanc, M., Klouche, K., Vela, C., & Beraud, J. J. (1998). Temporary vascular access for extracorporeal renal replacement therapies in acute renal failure patients. *Kidney International*, 53(Suppl. 66), S142 - S150.
- Canaud, B., Mion, C., Arujo, A., N' Guyen, V. Q., Paleyrac, G., Hemmendinger, S., et al. (1988). Prostacyclin (Epoprostenol) as the sole antithrombotic agent in postdilutional hemofiltration. *Nephron*, 48, 206-212.
- Candela, L., & Yucha, C. (2004). Renal regulation of extracellular fluid volume and osmolality. *Nephrology Nursing Journal*, 31(4), 397-404.
- Cardigan, R., McGloin, H., Mackie, I., Machin, S., & Singer, M. (1999). Activation of the tissue factor pathway occurs during continuous venovenous hemofiltration. *Kidney International*, 55, 1568-1574.

- Carr, J. A., & Silverman, N. (1999). The heparin-protamine interaction: A review. *Journal of Cardiovascular Surgery*, 40(5), 659-666.
- Cerda, J., Sheinfeld, G., & Ronco, C. (2010). Fluid Overload in Critically Ill Patients with Acute Kidney Injury. *Blood Purification*, 29, 331-338.
- Charles, J. C., & Heilman, R. L. (2005). Metabolic Acidosis. *Hospital Physician*, 41(3), 37-42.
- Chmielewski, C. (2003). Renal anatomy and overview of nephron function. *Nephrology Nursing Journal*, 30(2), 185-190.
- Choi, P., Yip, G., Quinonez, L., & Cook, D. (1999). Crystalloids vs. colloids in fluid resuscitation: A systematic review. *Critical Care Medicine*, 27(1), 200-210.
- Chong, B. H. (2003). Heparin-induced thrombocytopenia. *Journal of Thrombosis and Haemostasis*, 1, 1471-1478.
- Chow, S.-C., & Liu, J.-P. (2004). *Analysis of Clinical Trials: Concepts and Methodologies* (2nd ed.). New York: John Wiley & Sons Inc.
- Chrysochoou, G., Marcus, R. J., Sureshkumar, K. K., McGill, R. L., & Carlin, B. W. (2008). Renal Replacement Therapy in the Critical Care Unit. *Critical Care Nursing Quarterly*, 31(4), 282-290.
- Chung, K. K., Juncos, L. A., Wolf, S. E., Mann, E. E., Renz, E. M., White, C. E., et al. (2008). Continuous Renal Replacement Therapy Improves Survival in Severely Burned Military Casualties With Acute Kidney Injury. *The Journal of Trauma Injury, Infection and Critical Care*, 64(2), S179-S187.
- Clark, W. R., & Ronco, C. (2001). Determinants of haemodialyser performance and the potential effect on clinical outcome. *Nephrology Dialysis Transplantation*, 16(5 Suppl.), 56-60.
- Clark, W. R., Turk, J. E., Kraus, M. A., & Gao, D. (2003). Dose determinants in continuous renal replacement therapy. *Artificial Organs*, 27(9), 815-820.
- Clermont, G., Acker, C. G., Angus, D. C., Sirio, C. A., Pinsky, M. R., & Johnson, J. P. (2002). Renal failure in the ICU: Comparison of the impact of acute renal failure and end-stage renal disease on ICU outcomes. *Kidney International*, 62, 986-996.
- CochraneInjuriesGroupAlbuminReviewers. (1998). Human albumin administration in critically ill patients: systematic review of randomised controlled trials. *British Medical Journal*, 317, 235-240.
- Cointault, O., Kamar, N., Bories, P., Lavayssiere, L., Angles, O., Rostaing, L., et al. (2004). Regional citrate anticoagulation in continuous venovenous haemodiafiltration using commercial solutions. *Nephrology Dialysis Transplantation*, 19, 171-178.
- Cole, L., Bellomo, R., Hart, G., Journois, D., Davenport, P., Tipping, P., et al. (2002). A phase II randomized, controlled trial of continuous hemofiltration in sepsis. *Critical Care Medicine*, 30(1), 100-106.

- Cole, L., Bellomo, R., Journois, D., Davenport, P., Baldwin, I., & Tipping, P. (2001). High-volume haemofiltration in human septic shock. *Intensive Care Medicine*, 27, 978-986.
- Columb, M. O., & Stevens, A. (2008). Power analysis and sample size calculations. *Current Anaesthesia & Critical Care*, 19, 12-14.
- Conger, J. D. (1990). Does hemodialysis delay recovery from acute renal failure? *Seminars in Dialysis*, 3(3), 146-148.
- Coraim, F. I., & Wolner, E. (1995). Continuous hemofiltration for the failing heart. *New Horizons*, 3(4), 725-731.
- Costanzo, M. R., Guglin, M. E., Saltzberg, M. T., Jessup, M. L., Bart, B. A., Teerlink, J. R., et al. (2007). Ultrafiltration versus intravenous diuretics for patients hospitalized for acute decompensated heart failure. *Journal of the American College of Cardiology*, 49(6), 675-683.
- Cree, L., & Rischmiller, S. (2001). *Science In Nursing* (4 ed.). Sydney: Mosby.
- Cridle, L. (2003). Rhabdomyolysis: Pathophysiology, Recognition, and Management. *Critical Care Nurse*, 23(6), 14-30.
- Cruz, D., Bobek, I., Lentini, P., Soni, S., Chionh, C. Y., & Ronco, C. (2009). Machines for Continuous Renal Replacement Therapy. *Seminars in Dialysis*, 22(2), 123-132.
- Dahaba, A. A., Elawady, G. A., Rehak, P. H., & List, W. F. (2002). Procalcitonin and proinflammatory cytokine clearance during continuous venovenous haemofiltration in septic patients. *Anaesthesia and Intensive Care*, 30(3), 269-274.
- Daniel, W. W. (2005). *Biostatistics: A Foundation for Analysis in the Health Sciences* (8th ed.). New York: John Wiley & Sons, Inc.
- Davenport, A. (1997). The coagulation system in the critically ill patient with acute renal failure and the effect of an extracorporeal circuit. *American Journal of Kidney Diseases*, 30(5 Suppl 4), S20-S27.
- Davenport, A. (1998). Anticoagulation in patients with acute renal failure treated with continuous renal replacement therapies. *Hemodialysis International*, 2, 41-59.
- Davenport, A. (2004a). Anticoagulation for continuous renal replacement therapy. *Contributions to Nephrology*, 144, 228-238.
- Davenport, A. (2004b). Heparin-induced thrombocytopenia during renal replacement therapy. *Hemodialysis International*, 8, 295-303.
- Davenport, A., & Tolwani, A. J. (2009). Citrate anticoagulation for continuous renal replacement therapy (CRRT) in patients with acute kidney injury admitted to the intensive care unit. *NDT Plus*, 2, 439-447.

- Davenport, A., Will, E. J., & Davison, A. M. (1990a). Adverse effects of prostacyclin administered directly into patients with combined renal and respiratory failure prior to dialysis. *Intensive Care Medicine*, *16*, 431-435.
- Davenport, A., Will, E. J., & Davison, A. M. (1990b). Effect of the direction of dialysate flow on the efficiency of continuous arteriovenous haemodialysis. *Blood Purification*, *8*, 329-336.
- Davenport, A., Will, E. J., & Davison, A. M. (1991). Continuous vs. intermittent forms of haemofiltration and/or dialysis in the management of acute renal failure in patients with defective cerebral autoregulation at risk of cerebral oedema. *Contributions to Nephrology*, *93*, 225-233.
- Davenport, A., Will, E. J., & Davison, A. M. (1994). Comparison of the use of standard heparin and prostacyclin anticoagulation in spontaneous and pump-driven extracorporeal circuits in patients with combined acute renal and hepatic failure. *Nephron*, *66*, 431-437.
- Davies, H., & Leslie, G. D. (2006). Maintaining the CRRT circuit: Non-anticoagulant alternatives. *Australian Critical Care*, *19*(4), 133-138.
- Davies, H., & Leslie, G. D. (2007). Anticoagulation in CRRT: Agents and strategies in Australian ICUs. *Australian Critical Care*, *20*(1), 15-26.
- Davies, H., Morgan, D., & Leslie, G. (2008). A regional citrate anticoagulation protocol for pre-dilutional CVVHDF: The 'Modified Alabama Protocol'. *Australian Critical Care*, *21*(3), 154-165.
- de Mendonca, A., Vincent, J. L., Suter, P., Moreno, R., Dearden, N. M., Antonelli, M., et al. (2000). Acute renal failure in the ICU: Risk factors and outcome evaluated by the SOFA score. *Intensive Care Medicine*, *26*, 915-921.
- de Pont, A. C. J. M., Bouman, C. S. C., Jonge, E. d., Vroom, M. B., Buller, H. R., & Levi, M. (2003). Treatment with recombinant human activated protein C obviates additional anticoagulation during continuous venovenous hemofiltration in patients with severe sepsis. *Intensive Care Medicine*, *29*(7), 1205.
- de Pont, A. C. J. M., Oudemans-van Straaten, H. M., Roozendaal, K. J., & Zandstra, D. F. (2000). Nadroparin versus dalteparin anticoagulation in high-volume continuous venovenous hemofiltration: a double blind, randomized, crossover study. *Critical Care Medicine*, *28*, 421-425.
- de Vriese, A. S., Colardyn, F. A., Philippe, J. J., Vanholder, R., de Sutter, J. H., & Lameire, N. (1999). Cytokine removal during continuous hemofiltration in septic patients. *Journal of the American Society of Nephrology*, *10*, 846-853.
- Dellinger, R. P., Levy, M. M., Carlet, J., Bion, J., Parker, M. M., Jaeschke, R., et al. (2008). Surviving Sepsis Campaign: International guidelines for management of severe sepsis and septic shock: 2008. *Critical Care Medicine*, *36*(1).
- Dhondt, A., van Holder, R., van Biesen, W., & Lameire, N. (2000). The removal of uremic toxins. *Kidney International*, *58*(Suppl 76), S47-S59.

- DiMari, J., Megyesi, J., Udvarhelyi, N., Price, P., Davis, R., & Safirstein, R. (1997). N-acetyl cysteine ameliorates ischemic renal failure. *American Journal of Physiology*, 272(3), F292-F298.
- Dirkes, S. M. (2000). Continuous renal replacement therapy: Dialytic therapy for acute renal failure in intensive care. *Nephrology Nursing Journal*, 27(6), 581-590.
- Dirkes, S. M., & Hodge, K. (2007). Continuous renal replacement therapy in the adult intensive care unit: History and current trends. *Critical Care Nurse*, 27(2), 61-80.
- DO-RE-MIStudyGroup. (2009). Delivered dose of renal replacement therapy and mortality in critically ill patients with acute kidney injury. *Critical Care*, 13(2), R57-R70.
- Draper, N. R., & Smith, H. (1998). *Applied Regression Analysis* (3rd ed.). New York: Wiley.
- du Cheyron, D., Bouchet, B., Bruel, C., Daubin, C., Ramakers, M., & Charbonneau, P. (2006). Antithrombin supplementation for anticoagulation during continuous hemofiltration in critically ill patients with septic shock: A case-control study. *Critical Care*, 10(2), R45-51.
- Dungen, H.-D., von Heymann, C., Ronco, C., Kox, W. J., & Spies, C. (2001). Renal replacement therapy: Physical properties of hollow fibres influence efficiency. *The International Journal of Artificial Organs*, 24(6), 357-366.
- Durham, J. D., Caputo, C., Dokko, J., Zaharakis, T., Pahlavan, M., Keltz, J., et al. (2002). A randomized controlled trial of N-acetylcysteine to prevent contrast nephropathy in cardiac angiography. *Kidney International*, 62, 2202-2207.
- Ejaz, A. A., Komorski, R. M., Ellis, G. H., & Munjal, S. (2007). Extracorporeal circuit pressure profiles during continuous venovenous haemofiltration. *Nursing in Critical Care*, 12(2), 81-85.
- Evans, J. E. (1939). Why Logarithms to the Base e Can Justly be Called Natural Logarithms. *National Mathematics Magazine*, 14(2), 91-95.
- Evanson, J. A., Himmelfarb, J., Wingard, R. L., Knights, S., Shyr, Y., Schulman, G., et al. (1998). Prescribed Versus Delivered Dialysis in Acute Renal Failure Patients. *American Journal of Kidney Diseases*, 32(5), 731-738.
- Evenepoel, P. (2004). Acute toxic renal failure. *Best Practice & Research Clinical Anaesthesiology*, 18(1), 37-52.
- Farese, S., Jakob, S. M., Kalicki, R., Frey, F. J., & Uehlinger, D. E. (2009). Treatment of Acute Renal Failure in the Intensive Care Unit: Lower Costs by Intermittent Dialysis Than Continuous Venous Hemodiafiltration. *Artificial Organs*, 33(8), 634-640.
- Fealy, N., Baldwin, I., Johnstone, M., Egi, M., & Bellomo, R. (2007). A pilot randomized controlled crossover study comparing regional heparinization to regional citrate anticoagulation for continuous venovenous hemofiltration. *The International Journal of Artificial Organs*, 30(4), 301-307.

- Fiaccadori, E., Maggiore, U., Rotelli, C., Minari, M., Melfa, L., Cappe, G., et al. (2002). Continuous haemofiltration in acute renal failure with prostacyclin as the sole anti-haemostatic agent. *Intensive Care Medicine*, 28, 586-593.
- Fieghen, H., Wald, R., & Jaber, B. L. (2009). Renal Replacement Therapy for Acute Kidney Injury. *Nephron Clinical Practice*, 112(4), c222-c229.
- Finfer, S., Bellomo, R., Boyce, N., French, J., Myburgh, J., & Norton, R. (2004). A Comparison of Albumin and Saline for Fluid Resuscitation in the Intensive Care Unit. *New England Journal of Medicine*, 350(22), 2247-2256.
- Fischer, K. G. (2002). Hirudin in renal insufficiency. *Seminars in Thrombosis and Hemostasis*, 28(5), 467-482.
- Fischer, K. G., van de Loo, A., & Bohler, J. (1999). Recombinant hirudin (lepirudin) as anticoagulant in intensive care patients treated with continuous hemodialysis. *Kidney International*, 56(Suppl. 72), S46-S50.
- Fleiss, J. L. (1986). *The Design and Analysis of Clinical Experiments*. New York: John Wiley & Sons.
- Fletcher, J. J., Bergman, K., Feucht, E. C., & Blostein, P. (2009). Continuous Renal Replacement Therapy for Refractory Intracranial Hypertension. *Neurocritical Care*, 11, 101-105.
- Foot, C. L., & Fraser, J. F. (2005). So you need to start renal replacement therapy on your ICU patient? *Current Anaesthesia & Critical Care*, 16, 321-329.
- Frank, D., Farber, H., Lanzmich, R., Floege, J., & Kierdorf, H. (2002). In vitro studies on hirudin elimination by haemofiltration: comparison of three high-flux membranes. *Nephrology Dialysis Transplantation*, 17, 1957-1963.
- Friedrich, J., Adhikari, N., Herridge, M., & Beyene, J. (2005). Meta-Analysis: Low-Dose Dopamine Increases Urine Output but Does Not Prevent Renal Dysfunction or Death. *Annals of Internal Medicine*, 142(7), 510-524.
- Gastaldello, K., Melot, C., Kahn, R.-J., Vanherweghem, J.-L., Vincent, J.-L., & Tielemans, C. (2000). Comparison of cellulose diacetate and polysulfone membranes in the outcome of acute renal failure. A prospective randomized study. *Nephrology Dialysis Transplantation*, 15, 224-230.
- Gattinoni, L., Brazzi, L., Pelosi, P., Latini, R., Tognoni, G., Pesenti, A., et al. (1995). A trial of goal-oriented hemodynamic therapy in critically ill patients. *The New England Journal of Medicine*, 333(16), 1025-1032.
- Gauthier, P. M., & Szerlip, H. M. (2002). Metabolic acidosis in the intensive care unit. *Critical Care Clinics*, 18, 289-308.
- Geronemus, R., & Schneider, N. (1984). Continuous arteriovenous haemodialysis: a new modality for the treatment of acute renal failure. *Transactions of the American Society for Artificial Internal Organs*, 30, 610-613.

- Gettings, L. G., Reynolds, H. N., & Scalea, T. (1999). Outcome in post-traumatic acute renal failure when continuous renal replacement therapy is applied early versus late. *Intensive Care Medicine*, 25, 805-813.
- Goldhill, D. R., & Sumner, A. (1998). APACHE II, data accuracy and outcome prediction. *Anaesthesia*, 53(10), 937-943.
- Golper, T. (2002). Solute Transport in CRRT. In R. Bellomo, I. Baldwin, C. Ronco & T. Golper (Eds.), *Atlas of Haemofiltration* (pp. 15 - 18). Sydney: W. B. Saunders.
- Greinacher, A., Volpel, H., Janssens, U., Hach-Wunderle, V., Kemkes-Matthes, B., Eichler, P., et al. (1999). Recombinant hirudin (Lepirudin) provides safe and effective anticoagulation in patients with heparin-induced thrombocytopenia: A prospective study. *Circulation*, 99, 73-80.
- Gretz, N., Quintel, M., Ragaller, M., Odenwalder, W., Bender, H. J., Rhomeiss, P., et al. (1995). Low dose heparinization for anticoagulation in intensive care patients on continuous hemofiltration. *Contributions to Nephrology*, 116, 130-135.
- Gunal, A. I., Celiker, H., Dogukan, A., Ozalp, G., Kirciman, E., Simsekli, H., et al. (2004). Early and Vigorous Fluid Resuscitation Prevents Acute Renal Failure in the Crush Victims of Catastrophic Earthquakes. *Journal of the American Society of Nephology*, 15, 1862-1867.
- Guthrie, D., & Yucha, C. (2004). Urinary concentration and dilution. *Nephrology Nursing Journal*, 31(3), 297-301.
- Hakim, R. M. (1993). Hemodialysis membrane biocompatibility. *Kidney International*, 44, 484-494.
- Hakim, R. M., Wingard, R. L., & Parker, R. A. (1994). Effect of the dialysis membrane in the treatment of patients with acute renal failure. *The New England Journal of Medicine*, 331(20), 1338-1342.
- Hall, N. A., & Fox, A. J. (2006). Renal replacement therapies in critical care. *Continuing Education in Anaesthesia, Critical Care & Pain*, 6(5), 197-202.
- Heering, P., Grabensee, B., & Brause, M. (2003). Cytokine removal in septic patients with continuous venovenous hemofiltration. *Kidney & Blood Pressure Research*, 26, 128-134.
- Heering, P., Ivens, K., Thumer, O., Morgera, S., Heintzen, M., Passlick-Deetjen, J., et al. (1999). The use of different buffers during continuous hemofiltration in critically ill patients with acute renal failure. *Intensive Care Medicine*, 25, 1244-1251.
- Heering, P., Morgera, S., Schmitz, F. J., Willers, R., Schultheisis, H. P., Strauer, B. E., et al. (1997). Cytokine removal and cardiovascular hemodynamics in septic patients with continuous venovenous hemofiltration. *Intensive Care Medicine*, 23, 288-296.

- Hein, O. V., von Heymann, C., Diehl, T., Ziemer, S., Ronco, C., Morgera, S., et al. (2004). Intermittent hirudin versus continuous heparin for anticoagulation in continuous renal replacement therapy. *Renal Failure*, 26(3), 297-303.
- Hein, O. V., von Heymann, C., Lipps, M., Ziemer, S., Ronco, C., Neumayer, H., et al. (2001). Hirudin versus heparin for anticoagulation in continuous renal replacement therapy. *Intensive Care Medicine*, 27, 673-679.
- Henderson, L. W., Besarab, A., Michaels, A., & Bluemle, L. W. J. (1967). Blood purification by ultrafiltration and fluid replacement (diafiltration). *Transactions of the American Society for Artificial Internal Organs*, 17, 216-221.
- Henderson, L. W., Ford, C. A., Colton, C. K., Bluemle, L. W. J., & Bixler, H. J. (1970). Uremic blood cleansing by diafiltration using a hollow fiber ultrafilter. *Transactions of the American Society for Artificial Internal Organs*, 16, 107-114.
- Henderson, L. W., Livoti, L. G., Ford, C. A., Kelly, A. B., & Lysaght, M. J. (1973). Clinical experience with intermittent hemodiafiltration. *Transactions of the American Society for Artificial Organs*, 19, 119-123.
- Heritier, S. R., GebSKI, V., & Keech, A. C. (2003). Inclusion of patients in clinical trial analysis: The intention-to-treat principle. *Medical Journal of Australia*, 179, 438-440.
- Hesselvik, J. F., Malm, J., Dahlback, B., & Blomback, M. (1991). Protein C, Protein S and C4b-Binding Protein in severe infection and septic shock. *Thrombosis and Haemostasis*, 65(2), 126-129.
- Hillman, R. S., & Ault, K. A. (2002). Clinical Approach to Bleeding Disorders *Hematology in Clinical Practice* (3rd ed., pp. 308-315). New York: McGraw-Hill.
- Hilton, R. (2006). Acute Renal Failure. *British Medical Journal*, 333, 786-790.
- Himmelfarb, J. (2007). Continuous dialysis is not superior to intermittent dialysis in acute kidney injury of the critically ill patient. *Nature Clinical Practice Nephrology*, 3(3), 120-121.
- Himmelfarb, J., Rubin, N. T., Chandran, P., Parker, R. A., Wingard, R. L., & Hakim, R. M. (1998). A multicenter comparison of dialysis membranes in the treatment of acute renal failure requiring dialysis. *Journal of the American Society of Nephrology*, 9, 257-266.
- Ho, K. M. (2006). Hyperlactataemia induced by CVVHDF with low lactate bicarbonate-buffered solutions in patients with liver dysfunction. *Nephrology Dialysis and Transplantation*, 21, 1096-1099.
- Ho, K. M., & Morgan, D. (2009). Meta-analysis of N-Acetylcysteine to Prevent Acute Renal Failure After Major Surgery. *American Journal of Kidney Diseases*, 53(1), 33-40.
- Ho, K. M., & Sheridan, D. J. (2006). Meta-analysis of frusemide to prevent or treat acute renal failure. *British Medical Journal*, 333(7565), 420-425.

- Hoenich, N. A. (2007). Membranes and Filters for Haemodiafiltration. *Contributions to Nephrology*, 158, 57-67.
- Hoenich, N. A., Ronco, C., & Levin, R. (2006). The importance of water quality and haemodialysis fluid composition. *Blood Purification*, 24, 11-18.
- Hofbauer, R., Moser, D., Frass, M., Oberbauer, R., Kaye, A. D., Wagner, O., et al. (1999). Effect of anticoagulation on blood membrane interactions during haemodialysis. *Kidney International*, 56, 1578-1583.
- Hofmann, R. M., Maloney, C., Ward, D. M., & Becker, B. N. (2002). A novel method for regional citrate anticoagulation in continuous venovenous hemofiltration (CVVHF). *Renal Failure*, 24(3), 325-335.
- Holechek, M. J. (2003a). Glomerular Filtration: An overview. *Nephrology Nursing Journal*, 30(3), 285-290.
- Holechek, M. J. (2003b). Renal hemodynamics: An overview. *Nephrology Nursing Journal*, 30(4), 441-446.
- Hollenberg, N., Adams, D., Mendall, P., Abrams, H., & Merrill, J. (1973). Renal vascular responses to dopamine: haemodynamic and angiographic observations in normal man. *Clinical Science*, 45(733-742).
- Holt, A. W., Bierer, P., Bersten, A. D., Bury, L. K., & Vedig, A. E. (1996). Continuous renal replacement therapy in critically ill patients: Monitoring circuit function. *Anaesthesia and Intensive Care*, 24(4), 423-429.
- Holt, A. W., Bierer, P., Glover, P., Plummer, J. L., & Bersten, A. D. (2002). Conventional coagulation and thromboelastograph parameters and longevity of continuous renal replacement circuits. *Intensive Care Medicine*, 28, 1649-1655.
- Homsí, E., Barreiro, M., Orlando, J., & Higa, E. (1997). Prophylaxis of acute renal failure in patients with rhabdomyolysis. *Renal Failure*, 19(2), 283-288.
- Horrow, J. C. (1985). Protamine: A review of its toxicity. *Anesthesia and Analgesia*, 64, 348-361.
- Hoste, E. A. J., Clermont, G., Kersten, A., Venkataraman, R., Angus, D. C., de Bacquer, D., et al. (2006). RIFLE criteria for acute kidney injury are associated with hospital mortality in critically ill patients: A cohort analysis. *Critical Care*, 10(3), R73-R82.
- Hou, S., Bushinsky, D. A., Wish, J. B., Cohen, J. J., & Harrington, J. T. (1983). Hospital-acquired renal insufficiency: A prospective study. *The American Journal of Medicine*, 74(2), 243-248.
- Huang, Z., Gao, D., Letteri, J. J., & Clark, W. R. (2009). Blood-Membrane Interactions During Dialysis. *Seminars in Dialysis*, 22(6), 623-628.
- Hyman, A., & Mendelssohn, D. C. (2002). Current canadian approaches to dialysis for acute renal failure in the ICU. *American Journal of Nephrology*, 22, 29-34.

- Isenbarger, D. W., Kent, S. M., & O'Malley, P. (2003). Meta-Analysis of Randomized Clinical Trials on the Usefulness of Acetylcysteine for Prevention of Contrast Nephropathy. *The American Journal of Cardiology*, 92, 1454-1458.
- Jacka, M. J., Ivancinova, X., & Gibbney, N. (2005). Continuous renal replacement therapy improves renal recovery from acute renal failure. *Canadian Journal of Anesthesia*, 52(3), 327-332.
- Jeffrey, R. F., Khan, A. A., Douglas, J. T., Will, E. J., & Davison, A. M. (1993). Anticoagulation with low molecular weight heparin (Fragmin) during continuous hemodialysis in the intensive care unit. *Artificial Organs*, 17, 717-720.
- Jenkins, R. D. (1998). The extra-corporeal circuit: Physical principles and monitoring. In C. Ronco & R. Bellomo (Eds.), *Critical Care Nephrology* (1st ed.). Dordrecht: Kluwe Academic Publishers.
- Joannidis, M., Kountchew, J., Grote, A., Bellmann, R., Mayr, A., & Wiedermann, C. (2004). Unfractionated versus low-molecular-weight heparin (enoxaparin) for anticoagulation in CVVH (abstract). *Intensive Care Medicine*, 30, S155.
- Joannidis, M., Metnitz, B., Bauer, P., Schusterschitz, N., Moreno, R., Druml, W., et al. (2009). Acute kidney injury in critically ill patients classified by AKIN versus RIFLE using the SAPS 3 database. *Intensive Care Medicine*, 35(10), 1692-1702.
- Joannidis, M., & Oudemans-Van Straaten, H. M. (2007). Clinical review: Patency of the circuit in continuous renal replacement therapy. *Critical Care*, 11(4), 218-227.
- Jochimsen, F., Schafer, J.-H., Maurer, A., & Distler, A. (1990). Impairment of renal function in medical intensive care: Predictability of acute renal failure. *Critical Care Medicine*, 18(5), 480-485.
- John, R., & Herzenberg, A. M. (2009). Renal toxicity of therapeutic drugs. *Journal of Clinical Pathology*, 62, 505-515.
- John, S., & Eckardt, K.-U. (2007). Renal Replacement Strategies in the ICU. *Chest*, 132(4), 1379-1388.
- Johnston, R. V., Boiteau, P., Charlebois, K., Long, S., & David, U. (2004). Responding to tragic error: Lessons from Foothills Medical Centre. *Canadian Medical Association Journal*, 170(11), 1659-1660.
- JointFacultyofIntensiveCareMedicine. (2003). *Minimum Standards for Intensive Care Units*. Melbourne.
- Jones, B., & Kenward, M. G. (1989). *Design and Analysis of Cross-Over Trials*. London: Chapman and Hall.
- Jones, C. H. (1998). Continuous renal replacement therapy in acute renal failure: Membranes for CRRT. *Artificial Organs*, 22(1), 2-7.
- Jorres, A., Gahl, G. M., Dobis, C., Polenakovic, M. H., Cakalaroski, K., Rutkowski, B., et al. (1999). Haemodialysis-membrane biocompatibility and mortality of

patients with dialysis-dependent acute renal failure: a prospective randomised multicentre trial. *The Lancet*, 354, 1337-1341.

Judson, J. A., & Fisher, M. (2006). Intensive Care in Australia and New Zealand. *Critical Care Clinics*, 22, 407-423.

Kanagasundaram, N. S., Larive, A. B., & Paganini, E. P. (2003). A preliminary survey of bacterial contamination of the dialysate circuit in continuous veno-venous haemodialysis. *Clinical Nephrology*, 59, 47-55.

Kaplan, A. A., Longnecker, R. E., & Folkert, V. W. (1984). Continuous arteriovenous hemofiltration: A report of six month's experience. *Annals of Internal Medicine*, 100, 358-367.

Kaplan, A. A., & Petrillo, R. (1987). Regional Heparinization for Continuous Arterio-Venous Hemofiltration (CAVH). *Trans American Society of Artificial Organs*, 33, 312-315.

Kaplan, E. L., & Meier, P. (1958). Nonparametric estimation from incomplete observations. *Journal of the American Statistical Association*, 53(282), 457-481.

Kay, J., Chow, W. H., Chan, T. M., Lo, S. K., Kwok, O. H., Yip, A., et al. (2003). Acetylcysteine for Prevention of Acute Deterioration of Renal Function Following Elective Coronary Angiography and Intervention. *Journal of American Medical Association*, 289(5), 553-558.

Kelley, K. T. (2004). How Peritoneal Dialysis Works. *Nephrology Nursing Journal*, 31(5), 481-489.

Kellum, J. A., Angus, D. C., Johnson, J. P., Leblanc, M., Griffin, M., Ramakrishnan, N., et al. (2002). Continuous versus intermittent renal replacement therapy: a meta-analysis. *Intensive Care Medicine*, 28, 29-37.

Kellum, J. A., Bellomo, R., & Ronco, C. (2007). The Concept of Acute Kidney Injury and the RIFLE Criteria. *Contributions to Nephrology*, 156, 10-16.

Kellum, J. A., & Decker, J. M. (2001). Use of Dopamine in acute renal failure: A meta-analysis. *Critical Care Medicine*, 29(8), 1526-1531.

Kemp, H. J., Parnham, A., & Tomson, C. R. (2001). Urea kinetic modelling: A measure of dialysis adequacy. *Annals of Clinical Biochemistry*, 38, 20-27.

Kern, H., Ziemer, S., & Kox, W. J. (1999). Bleeding after intermittent or continuous r-hirudin during CVVH. *Intensive Care Medicine*, 25, 1311-1314.

Kielstein, J. T., Kretschmer, U., Ernst, T., Hafer, C., Bahr, M. J., Haller, H., et al. (2004). Efficacy and cardiovascular tolerability of extended dialysis in critically ill patients: A randomised controlled study. *American Journal of Kidney Diseases*, 43(2), 342-349.

Kim, I. B., Fealy, N., Baldwin, I., & Bellomo, R. (2010). Premature Circuit Clotting due to Likely Mechanical Failure during Continuous Renal Replacement Therapy. *Blood Purification*, 30, 79-83.

- KIMALplc. (1999). *Hygieia Plus Operator Manual*. Middlesex, England.
- Kirby, S., & Davenport, A. (1996). Haemofiltration/dialysis treatment in patients with acute renal failure. *Care of the Critically Ill*, 12(2), 54-56.
- Kirk, R. E. (1995). *Experimental Design: Procedures for the Behavioral Sciences* (3rd ed.). Pacific Grove: Brooks/Cole Publishing Company.
- Kirkwood, B. R. (1988). *Essentials of Medical Statistics*. London: Blackwell Science Ltd.
- Klenzak, J., & Himmelfarb, J. (2005). Sepsis and the kidney. *Critical Care Clinics*, 21, 211-222.
- Klingel, R., Schaefer, M., Schwarting, A., Himmelsbach, F., Altes, U., Uhlenbusch-Korwer, I., et al. (2004). Comparative analysis of procoagulatory activity of haemodialysis, haemofiltration and haemodiafiltration with a polysulfone membrane (APS) and with different modes of enoxaparin anticoagulation. *Nephrology Dialysis Transplantation*, 19, 164-170.
- Klouche, K., Cavadore, P., Portales, P., Clot, J., Canaud, B., & Beraud, J. J. (2002). Continuous veno-venous hemofiltration improves hemodynamics in septic shock without modifying TNF and IL6 plasma concentrations. *Journal of Nephrology*, 15(2), 150-157.
- Knaus, W. A., Draper, E. A., Wagner, D. P., & Zimmerman, J. E. (1985). APACHE II: a severity of disease classification system. *Critical Care Medicine*, 13, 818-829.
- Kox, W. J., Rohr, U., & Waurer, H. (1996). Practical aspects of renal replacement therapy. *International Journal of Artificial Organs*, 19, 100-105.
- Kozek-Langenecker, S. A., Kettner, S. C., Oismueller, C., Gonano, C., Speiser, W., & Zimpfer, M. (1998). Anticoagulation with prostaglandin E1 and unfractionated heparin during continuous venovenous hemofiltration. *Critical Care Medicine*, 26(7), 1208-1212.
- Kramer, P., Bohler, J., Kehr, A., Grone, H. J., Schrader, J., Matthaei, D., et al. (1982). Intensive care potential of continuous arteriovenous hemofiltration. *Transactions of the American Society for Artificial Internal Organs*, 28, 28-32.
- Kramer, P., Kaufhold, G., Grone, H. J., Rieger, J., Matthaei, D., Stokke, T., et al. (1980). Management of anuric intensive-care patients with arterio-venous haemofiltration. *The International Journal of Artificial Organs*, 3, 225-230.
- Kramer, P., Wigger, W., Rieger, J., Matthaei, D., & Scheler, F. (1977). Arteriovenous haemofiltration: a new and simple method for treatment of over-hydrated patients resistant to diuretics. *Klin Wochensh*, 55, 1121-1122.
- Kuitunen, A., Vento, A., Suojaranta-Ylinen, R., & Pettila, V. (2006). Acute renal failure after cardiac surgery: Evaluation of the RIFLE classification. *Annals of Thoracic Surgery*, 81, 542-546.

- Kumar, V. A., Craig, M., Depner, T. A., & Yeun, J. Y. (2000). Extended daily dialysis: A new approach to renal replacement for acute renal failure in the intensive care unit. *American Journal of Kidney Diseases*, 36(2), 294-300.
- Kumar, V. A., Yeun, J. Y., Depner, T. A., & Don, B. R. (2004). Extended daily dialysis vs. continuous hemodialysis for ICU patients with acute renal failure: A two-year single center report. *The International Journal of Artificial Organs*, 27(5), 371-379.
- Kutsogiannis, D. J., Gibney, R. T., Stollery, D., & Gao, J. (2005). Regional citrate versus systemic heparin anticoagulation for continuous renal replacement in critically ill patients. *Kidney International*, 67, 2361-2367.
- Kutsogiannis, D. J., Mayers, I., Chin, W. D., & Gibney, R. T. (2000). Regional citrate anticoagulation in continuous veno-venous hemodiafiltration. *American Journal of Kidney Diseases*, 35(5), 802-811.
- Lameire, N. (2005). The pathophysiology of acute renal failure. *Critical Care Clinics*, 21, 197-210.
- Lameire, N., Biesen, W. V., Hoste, E. A. J., & van Holder, R. (2009). The prevention of acute kidney injury an in-depth narrative review Part 2: Drugs in the prevention of acute kidney injury. *NDT Plus*, 2, 1-10.
- Lameire, N., Biesen, W. V., & Vanholder, R. (2005). Acute renal failure. *The Lancet*, 365(9457), 417-430.
- Lameire, N., De Vriese, A. S., & Vanholder, R. (2003). Prevention and nondialytic treatment of acute renal failure. *Current Opinion in Critical Care*, 9, 481-490.
- Lameire, N., van Biesen, W., van Holder, R., & Colardyn, F. A. (1998). The place of intermittent hemodialysis in the treatment of acute renal failure in the ICU patient. *Kidney International*, 53(Suppl 66), S110-119.
- Langenecker, S. A., Felfernig, M., Werba, A., Mueller, C. M., Chiari, A., & Zimpfer, M. (1994). Anticoagulation with prostacyclin and heparin during continuous venovenous hemofiltration. *Critical Care Medicine*, 22(11), 1774-1781.
- Langford, S., Slivar, S., Tucker, S. M., & Bourbonnais, F. F. (2008). Exploring CRRT practices in ICU: A survey of Canadian hospitals. *Dynamics: Official Journal of the Canadian Association of Critical Care Nurses*, 19(1), 18-23.
- Lauer, A., Saccaggi, A., Ronco, C., Belledonne, M., Glabman, S., & Bosch, J. (1983). Continuous arteriovenous haemofiltration in the critically ill patient: clinical use and operational characteristics. *Annals of Internal Medicine*, 99, 455-460.
- Leslie, G. D. (2003). *Unpublished CRRT audit data*. Royal Perth Hospital: Western Australia.
- Leslie, G. D., Jacobs, I. G., & Clarke, G. M. (1996). Proximally delivered dilute heparin does not improve circuit life in continuous veno-venous haemodiafiltration. *Intensive Care Medicine*, 22, 1261-1264.

- Leslie, G. D., & Thomas, M. A. B. (1991). Filter life with veno venous (CVVHD) compared to arteriovenous (CAVHD) haemodiafiltration in intensive care acute renal failure (abstract). *Anaesthesia and Intensive Care*, 19(3), 465-466.
- Leunissen, K. M. L., & van Hooff, J. P. (1988). Acetate or bicarbonate for haemodialysis ? *Nephrology Dialysis Transplantation*, 3, 1-7.
- Leverve, X., & Barnoud, D. (1998). Stress metabolism and nutritional support in acute renal failure. *Kidney International*, 53(Suppl 66), S62-S66.
- Levy, E. M., Viscoli, C. M., & Horwitz, R. I. (1996). The Effect of Acute Renal Failure on Mortality: A Cohort Analysis. *Journal of the American Medical Association*, 275(19), 1489-1494.
- Leyboldt. (2000). Solute fluxes in different treatment modalities. *Nephrology Dialysis Transplantation*, 15(Suppl 1), 3-9.
- Liano, F., Junco, E., Pascual, J., Madero, R., & Verde, E. (1998). The spectrum of acute renal failure in the intensive care unit compared with that seen in other settings. Madrid acute renal failure study group. *Kidney International*, 53(Suppl 66), S16-S24.
- Liano, F., & Pascual, J. (1996). Epidemiology of acute renal failure: A prospective, multicentre community-based study. Madrid acute renal failure study group. *Kidney International*, 50, 811-818.
- Lindhoff-Last, E., Betz, C., & Bauersachs, R. (2001). Use of a low-molecular-weight heparinoid (Danaparoid sodium) for continuous renal replacement therapy in intensive care patients. *Clinical and Applied Thrombosis/Hemostasis*, 7(4), 300-304.
- Ludlow, M. (2003). Renal Handling of Potassium. *Nephrology Nursing Journal*, 30(5), 493-497.
- Macias, W. L., & Clark, W. R. (1996). Acid-Base Balance in Continuous Renal Replacement Therapy. *Seminars in Dialysis*, 9(2), 145-151.
- Macias, W. L., Mueller, B. A., Scarim, S. K., Robinson, M., & Rudy, D. W. (1991). Continuous venovenous hemofiltration: An alternative to continuous arteriovenous hemofiltration and hemodiafiltration in acute renal failure. *American Journal of Kidney Diseases*, 18(4), 451-458.
- Maher, E. R., Robinson, K. N., Scobie, J. E., Farrimond, J. G., Browne, D. R. G., Sweny, P., et al. (1989). Prognosis of critically-ill patients with acute renal failure: APACHE II score and other predictive factors. *Quarterly Journal of Medicine*, 72(269), 857-866.
- Manns, B., Doig, C. J., Lee, H., Dean, S., Tonelli, M., Johnson, D., et al. (2003). Cost of acute renal failure requiring dialysis in the intensive care unit: Clinical and resource implications of renal recovery. *Critical Care Medicine*, 31(2), 449-455.
- Manns, M., Sigler, M. H., & Teehan, B. P. (1997). Intradialytic renal haemodynamics - potential consequences for the management of the patient with acute renal failure. *Nephrology Dialysis Transplantation*, 12, 870-873.

- Marieb, E. N., & Hoehn, K. (2007). *Human Anatomy & Physiology* (7th ed.). San Francisco: Pearson Benjamin Cummings.
- Marik, P. E., & Varon, J. (1999). Severity Scoring and Outcome Assessment: Computerized Predictive Models and Scoring Systems. *Critical Care Clinics*, *15*(3), 633-646.
- Marshall, M. R., Golper, T., Shaver, M. J., & Chatoth, D. K. (2001). Hybrid renal replacement modalities for the critically ill. *Contributions to Nephrology*, *132*, 252-257.
- Marshall, M. R., Ma, T., Galler, D., Patrick, A., Rankin, N., & Williams, A. B. (2004). Sustained low-efficiency daily diafiltration (SLEDD-f) for critically ill patients requiring renal replacement therapy: towards an adequate therapy. *Nephrology Dialysis Transplantation*, *19*, 877-884.
- Marthaler, M., & Keresztes, P. (2004). Evidence-based Practice for the Use of N-acetylcysteine. *Dimensions of Critical Care Nursing* *23*(6), 270-273.
- Martin, C., Papazian, L., Perrin, G., Saux, P., & Gouin, F. (1993). Norepinephrine or dopamine for the treatment of hyperdynamic septic shock ? *Chest*, *103*, 1826-1831.
- Martin, P. Y., Chevrolet, J. C., Suter, P., & Favre, H. (1994). Anticoagulation in patients treated by continuous venovenous hemofiltration: a retrospective study. *American Journal of Kidney Diseases*, *24*, 806-812.
- Mattu, A., Brady, W. J., & Robinson, D. A. (2000). Electrocardiographic Manifestations of Hyperkalemia. *American Journal of Emergency Medicine*, *18*(6), 721-729.
- Mc Donald, B. R., & Mehta, R. L. (1991). Decreased mortality in patients with acute renal failure undergoing continuous arteriovenous hemodialysis. *Contributions to Nephrology*, *93*, 51-56.
- Mehta, R. L. (1996). Anticoagulation strategies for continuous renal replacement therapies: What works? *American Journal of Kidney Diseases*, *28*(5 Suppl 3), S8-S14.
- Mehta, R. L., Dobos, G. J., & Ward, D. M. (1992). Anticoagulation in continuous renal replacement procedures. *Seminars in Dialysis*, *5*(1), 61-68.
- Mehta, R. L., Kellum, J. A., Shah, S. V., Molitoris, B. A., Ronco, C., Warnock, D. G., et al. (2007). Acute kidney injury network: Report of an initiative to improve outcomes in acute kidney injury. *Critical Care*, *11*(2), R31-R38.
- Mehta, R. L., & Letteri, J. M. (1999). Current status of renal replacement therapy for acute renal failure. *American Journal of Nephrology*, *19*(3), 377-382.
- Mehta, R. L., Mc Donald, B. R., Aguilar, M. M., & Ward, D. M. (1990). Regional citrate anticoagulation for continuous arteriovenous hemodialysis in critically ill patients. *Kidney International*, *38*, 976-981.

- Mehta, R. L., McDonald, B., Gabbai, F. B., Pahl, M., Pascual, M. T. A., Farkas, A., et al. (2001). A randomized clinical trial of continuous versus intermittent dialysis for acute renal failure. *Kidney International*, *60*, 1154-1163.
- Mehta, R. L., Pascual, M., Soroko, S., Savage, B. R., Himmelfarb, J., Ikizler, T. A., et al. (2004). Spectrum of acute renal failure in the intensive care unit: The PICARD experience. *Kidney International*, *66*, 1613-1621.
- Metnitz, P. G. H., Krenn, C. G., Steltzer, H., Lang, T., Ploder, J., Lenz, K., et al. (2002). Effect of acute renal failure requiring renal replacement therapy on outcome in critically ill patients. *Critical Care Medicine*, *30*(9), 2051-2058.
- Misra, M. (2008). Basic mechanisms governing solute and fluid transport in hemodialysis. *Hemodialysis International*, *12*, S25-S28.
- Misset, B., Timsit, J.-F., Chevret, S., Renaud, B., Tamion, F., & Carlet, J. (1996). A randomized cross-over comparison of the hemodynamic response to intermittent hemodialysis and continuous hemofiltration in ICU patients with acute renal failure. *Intensive Care Medicine*, *22*, 742-746.
- Mitchell, A., Daul, A. E., Beiderlinden, M., Schafers, R. F., Heemann, U., Kribben, A., et al. (2003). A new system for regional citrate anticoagulation in continuous venovenous hemodialysis (CVVHD). *Clinical Nephrology*, *59*(2), 106-114.
- Moher, D., Schulz, K. F., & Altman, D. (2001). The CONSORT Statement: Revised Recommendations for Improving the Quality of Reports of Parallel-Group Randomized Trials. *Journal of American Medical Association*, *285*(15), 1987-1991.
- Monchi, M., Berghmans, D., Ledoux, D., Canivet, J. L., Dubois, B., & Damas, P. (2004). Citrate vs. heparin for anticoagulation in continuous venovenous hemofiltration: a prospective randomized study. *Intensive Care Medicine*, *30*, 260-265.
- Morabito, S., Guzzo, I., Solazzo, A., Muzi, L., Luciani, R., & Pierucci, A. (2003). Continuous renal replacement therapies: Anticoagulation in the critically ill at high risk of bleeding. *Journal of Nephrology*, *16*, 566-571.
- Moran, T. A., & Viele, C. S. (2005). Normal Clotting. *Seminars in Oncology Nursing*, *21*(4), 1-11.
- Morgera, S., Haase, M., Kuss, T., Vargas-Hein, O., Zuckermann-Becker, H., Melzer, C., et al. (2006). Pilot study on the effects of high cutoff hemofiltration on the need for norepinephrine in septic patients with acute renal failure. *Critical Care Medicine*, *34*(8), 2099-2104.
- Morgera, S., Scholle, C., Voss, G., Haase, M., Vargas-Hein, O., Krausch, D., et al. (2004). Metabolic complications during regional citrate anticoagulation in continuous venovenous hemodialysis: Single-center experience. *Nephron Clinical Practice*, *97*, c131-c136.
- Morimatsu, H., Uchino, S., Bellomo, R., & Ronco, C. (2002). Continuous renal replacement therapy: Does technique influence azotemic control? *Renal Failure*, *24*(5), 645-653.

- Morimatsu, H., Uchino, S., Bellomo, R., & Ronco, C. (2003). Continuous renal replacement therapy: Does technique influence electrolyte and bicarbonate control? *International Journal of Artificial Organs*, 26(4), 289-296.
- Morris, P. E., Goad, A., Thompson, C., Taylor, K., Harry, B., Passmore, L., et al. (2008). Early intensive care unit mobility therapy in the treatment of acute respiratory failure. *Critical Care Medicine*, 36(8), 2238-2243.
- Mueller, C., Buerkle, G., Buettner, H. J., Petersen, J., Perruchoud, A. P., Eriksson, U., et al. (2002). Prevention of Contrast Media-Associated Nephropathy. *Archives of Internal Medicine*, 162, 329-336.
- Murch, P. (2005). Optimizing the fluid management of ventilated patients with suspected hypovolaemia. *Nursing in Critical Care*, 10(6), 279-288.
- Nagarik, A., Soni, S., Adikey, G., & Raman, A. (2010). Comparative study of anticoagulation versus saline flushes in continuous renal replacement therapy. *Saudi Journal of Kidney Diseases and Transplantation*, 21(3), 478.
- Naka, T., & Bellomo, R. (2004). Bench-to-bedside review: Treating acid-base abnormalities in the intensive care unit - the role of renal replacement therapy. *Critical Care*, 8(2), 108-114.
- Naka, T., Egi, M., Bellomo, R., Cole, L., French, C., Botha, J., et al. (2005). Commercial low-citrate anticoagulation haemofiltration in high risk patients with frequent filter clotting. *Anaesthesia and Intensive Care*, 33(5), 601-608.
- Nash, K., Hafeez, A., & Hou, S. (2002). Hospital-acquired renal insufficiency. *American Journal of Kidney Diseases*, 39, 930-936.
- NationalHealthandMedicalResearchCouncil. (1999). *National Statement On Ethical Conduct In Research Involving Humans*. Canberra: Commonwealth of Australia.
- NationalHealthandMedicalResearchCouncil. (2005). *National Health and Medical Research Council (NHMRC) additional levels of evidence and grades for recommendations for developers of guidelines: Pilot program 2005-2007*. Canberra: Commonwealth of Australia.
- Nigwekar, S. U., & Kandula, P. (2009). N-Acetylcysteine in Cardiovascular-Surgery-Associated Renal Failure: A Meta-Analysis. *The Annals of Thoracic Surgery* 87, 139-147.
- Novak, J. D., & Canas, A. J. (2006). The theory underlying concept maps and how to construct them. Retrieved August 15, 2008, from <http://cmap.ihmc.us/Publications/ResearchPapers/TheoryUnderlyingConceptMaps.pdf>
- Nowak, G., & Bucha, E. (1996). Quantitative determination of hirudin in blood and body fluids. *Seminars in Thrombosis and Hemostasis*, 22(2), 197-202.
- Nurmohamed, M. T., Berckmans, R. J., Morrien-Salomons, W. M., Berends, F., Hommes, D. W., Rijniere, J. J. M. M., et al. (1994). Monitoring anticoagulant therapy by activated partial thromboplastin time: Hirudin assessment. *Thrombosis and Haemostasis*, 72(5), 685-692.

- Nyirenda, M. J., Tang, J. I., Padfield, P. L., & Seckl, J. R. (2009). Hyperkalaemia. *British Medical Journal*, 339, 1019-1024.
- O'Reilly, P., & Tolwani, A. J. (2005). Renal Replacement Therapy III: IHD, CRRT, SLED. *Critical Care Clinics*, 21, 367-378.
- Olbricht, C., Mueller, H., Schurek, H. J., & Stolte, H. (1982). Treatment of acute renal failure in patients with multiple organ failure by continuous spontaneous hemofiltration. *Transactions of the American Society for Artificial Internal Organs*, 28, 33-37.
- Oliver, M. J. (2001). Acute Dialysis Catheters. *Seminars in Dialysis*, 14(6), 432-435.
- Opatrny, K. J., Polanska, K., Krouzecky, A., Vit, L., Novak, I., & Kasal, E. (2002). The effect of heparin rinse on the biocompatibility of continuous veno-venous hemodiafiltration. *International Journal of Artificial Organs*, 25(6), 520-528.
- Oudemans-van Straaten, H. M., Wester, J. P. J., de Pont, A. C. J. M., & Schetz, M. (2006). Anticoagulation strategies in continuous renal replacement therapy: Can the choice be evidence based? [Review]. *Intensive Care Medicine*, 32, 188-202.
- Overberger, P., Pesacreta, M., & Palevsky, P. M. (2007). Management of renal replacement therapy in acute kidney injury: A survey of practitioner prescribing practices. *Clinical Journal of the American Society of Nephrology*, 2, 623-630.
- Paganini, E. P., Tapolyai, M., Goormastic, M., Halstenberg, W., Kozlowski, L., Leblanc, M., et al. (1996). Establishing a dialysis therapy/patient outcome link in intensive care unit acute dialysis for patients with acute renal failure. *American Journal of Kidney Diseases*, 28(5 Suppl. 3), S81-S89.
- Palevsky, P. M. (2009). Renal Support in Acute Kidney Injury-How Much Is Enough? [Editorial]. *New England Journal of Medicine*, 361(17), 1699-1701.
- Palsson, R., & Niles, J. L. (1999). Regional citrate anticoagulation in continuous venovenous hemofiltration in critically ill patients with a high risk of bleeding. *Kidney International*, 55, 1991-1997.
- Pannu, N., & Mehta, R. L. (2004). Effect of mechanical ventilation on the kidney. *Best Practice & Research Clinical Anaesthesiology*, 18(1), 189-203.
- Parianti, J.-J., Thirion, M., Megarbane, B., Souweine, B., Ouchikhe, A., Polito, A., et al. (2008). Femoral vs Jugular Venous Catheterization and Risk of Nosocomial Events in Adults Requiring Acute Renal Replacement Therapy: A Randomized Controlled Trial. *Journal of the American Medical Association*, 299(20), 2413-2422.
- Parikh, C. R., & Devarajan, P. (2008). New biomarkers of acute kidney injury. *Critical Care Medicine*, 36(4 suppl.), S159-S165.
- Parsons, H. M. (1974). What happened at Hawthorne? *Science*, 183, 922-932.
- Pascual, M., Swinford, R. D., & Tolkoff-Rubin, N. (1997). Acute Renal Failure: Role of Dialysis Membrane Biocompatibility. *Annual Review of Medicine*, 48, 467-476.

- Pastan, S., & Bailey, J. (1998). Dialysis Therapy. *New England Journal of Medicine*, 338(20), 1428-1437.
- Payen, D., Corneli e de Pont, A., Sakr, Y., Spies, C., Reinhart, K., & Vincent, J. L. (2008). A positive fluid balance is associated with a worse outcome in patients with acute renal failure. *Critical Care*, 12, R74-R80.
- Pendras, J. P., & Erickson, R. V. (1966). Hemodialysis: A Successful Therapy for Chronic Uremia. *Annals of Internal Medicine*, 64(2), 293-311.
- Pereira, S. M., & Leslie, G. (2009). Hypothesis testing. *Australian Critical Care*, 22(4), 187-191.
- Perkins, C., & Kisiel, M. (2005). Utilizing physiological knowledge to care for acute renal failure. *British Journal of Nursing*, 14(14), 768-773.
- Phu, N. H., Hien, T. T., Mai, N. T. H., Chau, T. T. H., Chuong, L. V., Loc, P. P., et al. (2002). Hemofiltration and peritoneal dialysis in infection-associated acute renal failure in Vietnam. *New England Journal of Medicine*, 347(12), 895-902.
- Polaschegg, H.-D. (1995). The Extracorporeal Circuit. *Seminars in Dialysis*, 8(5), 299-304.
- Polson, R. J., Park, G. R., Lindop, M. J., Farman, J. V., Calne, R. Y., & Williams, R. (1987). The prevention of renal impairment in patients undergoing orthotopic liver grafting by infusion of low dose dopamine. *Anaesthesia*, 42, 15-19.
- Ponikvar, J. B., Rus, R. R., Kenda, R. B., Bren, A. F., & Ponikvar, R. (2001). Low-flux versus high-flux synthetic dialysis membrane in acute renal failure: Prospective randomized study. *Artificial Organs*, 25(12), 946-950.
- Ponikvar, R., Kandus, A., Buturovic, J., & Kveder, R. (1991). Use of prostacyclin as the only anticoagulant during continuous venovenous hemofiltration. *Contributions to Nephrology*, 93, 218-220.
- Potzsch, B., Madlener, K., Seelig, C., Riess, C. F., Greinacher, A., & Muller-Berghaus, G. (1997). Monitoring of r-hirudin anticoagulation during cardiopulmonary bypass: Assessment of the whole blood ecarin clotting time. *Thrombosis and Haemostasis*, 77(5), 920-925.
- Prasad, G. V. R., Palevsky, P. M., Burr, R., Lesko, J. M., Gupta, B., & Greenberg, A. (2000). Factors affecting system clotting in continuous renal replacement therapy: results of a randomised, controlled trial. *Clinical Nephrology*, 53(1), 55-60.
- Prowle, J. R., Echeverri, J. E., Ligabo, E. V., Ronco, C., & Bellomo, R. (2010). Fluid balance and acute kidney injury. *Nature Reviews/Nephrology*, 6, 107-115.
- Ragaller, M., Theilen, H., & Koch, T. (2001). Volume replacement in critically ill patients with acute renal failure. *Journal of the American Society of Nephrology*, 12(Suppl 17), S33-S39.
- Rangel-Frausto, M. S., Pittet, D., Costigan, M., Hwang, T., Davis, C. S., & Wenzel, R. P. (1995). The natural history of the systemic inflammatory response syndrome

(SIRS): A prospective study. *Journal of the American Medical Association*, 273(2), 117-123.

- Reeves, J. H., Cumming, A. R., Gallagher, L., O'Brien, J. L., & Santamaria, J. D. (1999). A controlled trial of low-molecular-weight heparin (dalteparin) versus unfractionated heparin as anticoagulant during continuous venovenous hemodialysis with filtration. *Critical Care Medicine*, 27(10), 2224-2228.
- Reeves, J. H., Seal, P. F., Voss, A. L., & O'Connor, C. (1997). Albumin priming does not prolong hemofilter life. *American Society of Artificial Internal Organs Journal*, 43, 193-196.
- RENALReplacementTherapyStudyInvestigators. (2008). Renal replacement therapy for acute kidney injury in Australian and New Zealand intensive care units: A practice survey. *Critical Care and Resuscitation*, 10, 225-230.
- RENALReplacementTherapyStudyInvestigators. (2009). Intensity of Continuous Renal- Replacement Therapy in Critically Ill Patients. *The New England Journal of Medicine*, 361(17), 1627-1638.
- Ricci, Z., Bonello, M., Salvatori, G., Ratanarat, R., Brendolan, A., Dan, M., et al. (2004). Continuous renal replacement technology: From adaptive devices to flexible multipurpose machines. *Critical Care and Resuscitation*, 6, 180-187.
- Ricci, Z., & Ronco, C. (2005). Renal Replacement II: Dialysis Dose. *Critical Care Clinics*, 21, 357-366.
- Ricci, Z., & Ronco, C. (2008). Dose and efficiency of renal replacement therapy: Continuous renal replacement therapy versus intermittent hemodialysis versus slow extended daily dialysis. *Critical Care Medicine*, 36(4), S229-S237.
- Ricci, Z., Ronco, C., Bachetoni, A., D'amico, G., Rossi, S., Alessandri, E., et al. (2006). Solute removal during continuous renal replacement therapy in critically ill patients: Convection versus diffusion. *Critical Care*, 10(2), R67-R73.
- Ricci, Z., Ronco, C., D'amico, G., Felice, R. D., Rossi, S., Bolgan, I., et al. (2006). Practice patterns in the management of acute renal failure in the critically ill patient: An international survey. *Nephrology Dialysis and Transplantation*, 21, 690-696.
- Richardson, A., Reynolds, C., & Rodgers, R. (2006). Utilizing audit to evaluate improvements in continuous veno-venous haemofiltration practices in intensive therapy unit. *Nursing in Critical Care*, 11(4), 154-160.
- Rischbieth, A., & Blythe, D. (2005). *Ethics Handbook for Researchers*. Melbourne: The Australian and New Zealand Intensive Care Society (ANZICS) Clinical Trials Group (CTG).
- Rivers, E., Nguyen, B., Havstad, S., Ressler, J., Muzzin, A., Knoblich, B., et al. (2001). Early goal-directed therapy in the treatment of severe sepsis and septic shock. *The New England Journal of Medicine*, 345(19), 1368-1377.

- Roberts, M., & Winney, R. J. (1992). Errors in fluid balance with pump control of continuous hemodialysis. *The International Journal of Artificial Organs*, 15(2), 99-102.
- Ronco, C., & Bellomo, R. (2003). Prevention of acute renal failure in the critically ill. *Nephron Clinical Practice*, 93, c13-c20.
- Ronco, C., & Bellomo, R. (2007). Dialysis in Intensive Care Unit Patients with Acute Kidney Injury: Continuous Therapy is Superior. *Clinical Journal of the American Society of Nephrology*, 2, 597-600.
- Ronco, C., Bellomo, R., Homel, P., Brendolan, A., Maurizio, D., Piccinni, P., et al. (2000). Effects of different doses in continuous veno-venous haemofiltration on outcomes of acute renal failure: a prospective randomised trial. *The Lancet*, 356, 26-30.
- Ronco, C., Bellomo, R., & Ricci, Z. (2001). Continuous renal replacement therapy in critically ill patients. *Nephrology Dialysis Transplantation*, 16(Suppl5), 67-72.
- Ronco, C., Brendolan, A., & Bellomo, R. (2001). Continuous Renal Replacement Techniques. *Contributions to Nephrology*, 132, 236-251.
- Ronco, C., Crepaldi, C., Brendolan, A., Bragantini, L., D'Intini, V., Inguaggiato, P., et al. (2003). Evolution of synthetic membranes for blood purification: The case of the polyflux family. *Nephrology Dialysis Transplantation*, 18(Suppl. 7), vii10-vii20.
- Ronco, C., & Levin, N. (2005). Mechanisms of solute transport in extracorporeal therapies. *Contributions to Nephrology*, 149, 10-17.
- Ronco, C., Ricci, Z., Bellomo, R., & Bedogni, F. (2001). Extracorporeal ultrafiltration for the treatment of overhydration and congestive heart failure. *Cardiology*, 96, 155-168.
- Sakai, K. (2000). Dialysis membranes for blood purification. *Frontiers of Medical and Biological Engineering*, 10(2), 117-129.
- Sakr, Y., Vincent, J.-L., Reinhart, K., Groeneveld, J., Michalopoulos, A., Sprung, C., et al. (2005). High tidal volume and positive fluid balance are associated with worse outcome in Acute Lung Injury. *Chest*, 128(5), 3098-3108.
- Salmon, J., Cardigan, R., Mackie, I., Cohen, S. L., Machin, S., & Singer, M. (1997). Continuous venovenous haemofiltration using polyacrylonitrile filters does not activate contact system and intrinsic coagulation pathways. *Intensive Care Medicine*, 23, 38-43.
- Santos, W. J. Q., Zanetta, D. M. T., Pires, A. C., Lobo, S. M. A., Lima, E. Q., & Burdmann, E. A. (2006). Patients with ischaemic, mixed and nephrotoxic acute tubular necrosis in the intensive care unit - a homogeneous population? *Critical Care*, 10, R68-R76.
- Sarkar, S. (2009). Continuous Renal Replacement Therapy (CRRT). *The Internet Journal of Anesthesiology*, 21(1).

- Saudan, P., Niederberger, M., de Seigneux, S., Romand, J., Pugin, J., Perneger, T., et al. (2006). Adding a dialysis dose to continuous hemofiltration increases survival in patients with acute renal failure. *Kidney International*, 70(7), 1312-1317.
- Schaefer, J.-H., Jochimsen, F., Keller, F., Wegscheider, K., & Distler, A. (1991). Outcome prediction of acute renal failure in medical intensive care. *Intensive Care Medicine*, 17, 19-24.
- Scheeren, T., & Radermacher, P. (1997). Prostacyclin (PG12): New aspects of an old substance in the treatment of critically ill patients. *Intensive Care Medicine*, 23, 146-158.
- Schetz, M. (1998). Coagulation disorders in acute renal failure. *Kidney International*, 53(Suppl 66), S96-S101.
- Schetz, M. (2001). Anticoagulation for continuous renal replacement therapy. *Current Opinion in Anaesthesiology*, 14, 143-149.
- Schetz, M. (2004). Should we use diuretics in acute renal failure? *Best Practice & Research Clinical Anaesthesiology*, 18(1), 75-89.
- Schetz, M., Leblanc, M., & Murray, P. (2002). The Acute Dialysis Quality Initiative-part VII: Fluid composition and management in CRRT. *Advances in Renal Replacement Therapy*, 9(4), 282-289.
- Schiffl, H., Lang, S. M., & Fischer, R. (2002). Daily hemodialysis and the outcome of acute renal failure. *The New England Journal of Medicine*, 346(5), 305-310.
- Schiffl, H., Lang, S. M., Konig, A., Strasser, T., Haider, M. C., & Held, E. (1994). Biocompatible membranes in acute renal failure: prospective case-controlled study. *The Lancet*, 344, 570-572.
- Schortgen, F., Soubrier, N., Delclaux, C., Thuong, M., Girou, E., Brun-Buisson, C., et al. (2000). Hemodynamic tolerance of intermittent hemodialysis in critically ill patients. *American Journal of Respiratory and Critical Care Medicine*, 162, 197-202.
- Schrier, R. W. (2006). Role of diminished renal function in cardiovascular mortality. *Journal of the American College of Cardiology*, 47(1), 1-8.
- Schweickert, W. D., Pohlman, A. S., Nigos, C., Pawlik, A. J., Esbrook, C. L., Spears, L., et al. (2009). Early physical and occupational therapy in mechanically ventilated, critically ill patients: a randomised controlled trial. *Lancet*, 373, 1874-1882.
- Shilliday, I. R., Quinn, K. J., & Allison, M. E. M. (1997). Loop diuretics in the management of acute renal failure: A prospective, double-blind, placebo-controlled, randomized study. *Nephrology Dialysis Transplantation*, 12, 2592-2596.
- Shulman, R. I., Singer, M., & Rock, J. (2002). Keeping the circuit open: Lessons from the lab. *Blood Purification*, 20, 275-281.

- Sieffert, E., Mateo, J., Deligeon, N., & Payen, D. (1997). Continuous veno-venous hemofiltration (CVVH) using heparin-coated or non-heparin-coated membranes in critically ill patients (abstract). *Blood Purification*, 15, 125.
- Sigler, M. H., & Manns, M. (1996). Membranes and Devices Used in Continuous Renal Replacement Therapy. *Seminars in Dialysis*, 9(2), 98-106.
- Silvester, W., Bellomo, R., & Cole, L. (2001). Epidemiology, management and outcome of severe acute renal failure of critical illness in Australia. *Critical Care Medicine*, 29, 1910-1915.
- Singer, M., McNally, T., Screatton, G., Mackie, I., Machin, S., & Cohen, S. L. (1994). Heparin clearance during continuous veno-venous haemofiltration. *Intensive Care Medicine*, 20, 212-215.
- Singri, N., Ahya, S. N., & Levin, M. L. (2003). Acute Renal Failure. *Journal of the American Medical Association*, 289(6), 747-751.
- Solomon, R., Werner, C., Mann, D., D'Elia, J., & Silva, P. (1994). Effects of Saline, Mannitol and Furosemide on acute decreases in renal function induced by radiocontrast agents. *New England Journal of Medicine*, 331(21), 1416-1420.
- Stefanidis, I., Hagel, J., Frank, D., & Maurin, N. (1996). Hemostatic alterations during continuous venovenous hemofiltration in acute renal failure. *Clinical Nephrology*, 46(3), 199-205.
- Storck, M., Hartl, H. W., Zimmerer, E., & Inthorn, D. (1991). Comparison of pump-driven and spontaneous continuous haemofiltration in postoperative acute renal failure. *Lancet*, 337, 452-455.
- Subramanian, S., & Kellum, J. A. (2000). Convection of diffusion in continuous renal replacement therapy for sepsis. *Current Opinion in Critical Care*, 6, 426-430.
- Subramanian, S., Venkataraman, R., & Kellum, J. A. (2002). Influence of dialysis membranes on outcomes in acute renal failure: A meta-analysis. *Kidney International*, 62(5), 1819-1823.
- Swartz, R. D., Messana, J. M., Orzol, S., & Port, F. K. (1999). Comparing continuous hemofiltration with hemodialysis in patients with severe acute renal failure. *American Journal of Kidney Diseases*, 34(3), 424-432.
- Tabachnick, B. G., & Fidell, L. S. (2001). *Using multivariate statistics* (4th ed.). New York: Harper Collins.
- Tan, H. K., Baldwin, I., & Bellomo, R. (2000). Continuous veno-venous haemofiltration without anticoagulation in high-risk patients. *Intensive Care Medicine*, 26, 1652-1657.
- Tan, H. K., Bridge, N., Baldwin, I., & Bellomo, R. (2002). An ex-vivo evaluation of vascular catheters for continuous hemofiltration. *Renal Failure*, 24(6), 755-762.
- Tepel, M., van der Giet, M., Schwarzfeld, C., Laufer, U., Liermann, D., & Zidek, W. (2000). Prevention of radiographic-contrast-agent-induced reductions in renal

- function by acetylcysteine. *The New England Journal of Medicine*, 343(3), 180-184.
- Thadhani, R., Pascual, M., & Bonventre, J. V. (1996). Acute Renal Failure. *The New England Journal of Medicine*, 334(22), 1448-1460.
- Thakar, C. V., Christianson, A., Freyberg, R., Almenoff, P., & Render, M. L. (2009). Incidence and outcomes of acute kidney injury in intensive care units: A Veterans Administration study. *Critical Care Medicine*, 37(9), 2552-2558.
- The30thANZDATARegistryReport. (2007). Adelaide, South Australia: Australia and New Zealand Dialysis and Transplant Registry.
- Thomas, M. C., & Harris, D. C. H. (2002). Problems and advantages of continuous renal replacement therapy. *Nephrology*, 7(3), 110-114.
- Thomson, H., & Macnab, R. (2009). Fluid and electrolyte problems in renal dysfunction. *Anaesthesia and Intensive Care Medicine*, 10(6), 289-292.
- Tolwani, A. J., Campbell, R. C., Schenk, M. B., Allon, M., & Warnock, D. G. (2001). Simplified citrate anticoagulation for continuous renal replacement therapy. *Kidney International*, 60, 370-374.
- Tolwani, A. J., Prendergast, M. B., Speer, R. R., Stofan, B. S., & Wille, K. M. (2006). A practical citrate anticoagulation continuous venovenous hemodiafiltration protocol for metabolic control and high solute clearance. *Clinical Journal of the American Society of Nephrology*, 1(1), 79-87.
- Tolwani, A. J., & Wille, K. M. (2009). Anticoagulation for Continuous Renal Replacement Therapy. *Seminars in Dialysis*, 22(2), 141-145.
- Tonelli, M., Manns, B., & Feller-Kopman, D. (2002). Acute renal failure in the intensive care unit: a systematic review of the impact of dialytic modality on mortality and renal recovery. *American Journal of Kidney Diseases*, 40(5), 875-885.
- Troyanov, S., Geadah, D., Ghannoum, M., Cardinal, J., & Leblanc, M. (2004). Phosphate addition to hemofiltration solutions during continuous renal replacement therapy. *Intensive Care Medicine*, 30, 1662-1665.
- Tumlin, J., Stacul, F., Adam, A., Becker, C. R., Davidson, C., Lameire, N., et al. (2006). Pathophysiology of Contrast-Induced Nephropathy. *The American Journal of Cardiology*, 98, 14-20.
- Uchino, S. (2006). The epidemiology of acute renal failure in the world. *Current Opinion in Critical Care*, 12, 538-543.
- Uchino, S., Bellomo, R., Goldsmith, D., Bates, S., & Ronco, C. (2006). An assessment of the RIFLE criteria for acute renal failure in hospitalized patients. *Critical Care Medicine*, 34(7), 1913-1917.
- Uchino, S., Bellomo, R., Morimatsu, H., Morgera, S., Schetz, M., Tan, I., et al. (2007). Continuous renal replacement therapy: A worldwide practice survey. The

Beginning and Ending Supportive Therapy for the Kidney (B.E.S.T. Kidney) Investigators. *Intensive Care Medicine*, 33, 1563-1570.

Uchino, S., Bellomo, R., & Ronco, C. (2001). Intermittent versus continuous renal replacement therapy in the ICU: Impact on electrolyte and acid-base balance. *Intensive Care Medicine*, 27, 1037-1043.

Uchino, S., Doig, G. S., Bellomo, R., Morimatsu, H., Morgera, S., Schetz, M., et al. (2004). Diuretics and mortality in acute renal failure. *Critical Care Medicine*, 32(8), 1669-1677.

Uchino, S., Fealy, N., Baldwin, I., Morimatsu, H., & Bellomo, R. (2003a). Continuous is not continuous: the incidence and impact of circuit down-time on ureamic control during continuous veno-venous haemofiltration. *Intensive Care Medicine*, 29, 575-578.

Uchino, S., Fealy, N., Baldwin, I., Morimatsu, H., & Bellomo, R. (2003b). Pre-dilution versus Post-dilution during continuous veno-venous hemofiltration: impact on filter and azotemic control. *Nephron Clinical Practice*, 94, c94-c98.

Uchino, S., Fealy, N., Baldwin, I., Morimatsu, H., & Bellomo, R. (2004). Continuous venovenous hemofiltration without anticoagulation. *American Society of Artificial Internal Organs Journal*, 50, 76-80.

Uchino, S., Kellum, J. A., Bellomo, R., Doig, G. S., Morimatsu, H., Morgera, S., et al. (2005). Beginning and Ending Supportive Therapy for the Kidney (B.E.S.T. Kidney) Investigators. Acute renal failure in critically ill patients. A multinational, multicenter study. *Journal of the American Medical Association*, 294(7), 813-818.

Uehlinger, D. E., Jakob, S. M., Ferrari, P., Eichelberger, M., Huynh-Do, U., Marti, H.-P., et al. (2005). Comparison of continuous and intermittent renal replacement therapy for acute renal failure. *Nephrology Dialysis Transplantation*, 20, 1630-1637.

Uldall, R. (1996). Vascular access for continuous renal replacement therapy. *Seminars in Dialysis*, 9(2), 93-97.

van Biesen, W., Vanholder, R., & Lameire, N. (2003). Dialysis strategies in critically ill acute renal failure patients. *Current Opinion in Critical Care*, 9, 491-495.

van Biesen, W., Veys, N., & Vanholder, R. (2007). Intermittent Hemodialysis for Replacement Therapy in Intensive Care: New Evidence for Old Truths. *Contributions to Nephrology*, 156, 304-308.

van Bommel, E. F. H. (1995). Are continuous therapies superior to intermittent haemodialysis for acute renal failure on the intensive care unit? *Nephrology Dialysis Transplantation*, 10, 311-314.

van Bommel, E. F. H., Bouvy, N. D., So, K. L., Zietse, R., Vincent, H. H., Bruining, H. A., et al. (1995). Acute dialytic support for the critically ill: Intermittent hemodialysis versus continuous arteriovenous hemodiafiltration. *American Journal of Nephrology*, 15, 192-200.

- van Bommel, E. F. H., & Ponssen, H. H. (1997). Intermittent versus continuous treatment for acute renal failure: Where do we stand? *American Journal of Kidney Diseases*, 30(5 Suppl 4), S72-S79.
- van de Wetering, J., Westendorp, R. G. J., van der Hoeven, J. G., Stolk, B., Feuth, J. D. M., & Chang, P. C. (1996). Heparin use in continuous renal replacement procedures: the struggle between filter coagulation and patient haemorrhage. *Journal of the American Society of Nephology*, 7(1), 145-150.
- van der Voort, P. H. J., Gerritsen, R. T., Kuiper, M. A., Egbers, P. H. M., Kingma, W. P., & Boerma, E. C. (2005). Filter run time in CVVH: Pre-versus Post-dilution and Nadroparin versus Regional Heparin-Protamine anticoagulation. *Blood Purification*, 23, 175-180.
- van Holder, R., & de Smet, R. (1999). Pathophysiologic effects of uremic retention solutes. *Journal of the American Society of Nephology*, 10, 1815-1823.
- Venkataraman, R., Kellum, J. A., & Palevsky, P. M. (2002). Dosing Patterns for Continuous Renal Replacement Therapy at A Large Academic Medical Center in the United States. *Journal of Critical Care*, 17(4), 246-250.
- Vesely, T. M. (2003). Central Venous Catheter Tip Position: A Continuing Controversy. *Journal of Vascular and Interventional Radiology*, 14, 527-534.
- Vinsonneau, C., Camus, C., Combes, A., Costa de Beauregard, M. A., Klouche, K., Boulain, T., et al. (2006). Continuous venovenous haemodiafiltration versus intermittent haemodialysis for acute renal failure in patients with multiple-organ dysfunction syndrome: a multicentre randomised trial. *Lancet*, 368, 379-385.
- von Baeyer, H., Lajous-Petter, A., Debrandt, W., Hampl, H., Kochinkle, F., & Herbst, R. (1988). Surface reactions on blood contact during haemodialysis and haemofiltration with various membrane types. *Journal of Membrane Science*, 36, 215-229.
- Vun, C. M., Evans, S., & Chong, B. H. (1996). Cross-reactivity study of low molecular weight heparins and heparinoid in heparin-induced thrombocytopenia. *Thrombosis Research*, 81(5), 525-532.
- Waikar, S. S., Curhan, G. C., Wald, R., McCarthy, E. P., & Chertow, G. M. (2006). Declining mortality in patients with acute renal failure 1988 to 2002. *Journal of American Society of Nephology*, 17, 1143-1150.
- Waksman, R., Weiss, A. T., Gotsman, M. S., & Hasin, Y. (1993). Intra-aortic balloon counterpulsation improves survival in cardiogenic shock complicating acute myocardial infarction. *European Heart Journal*, 14, 71-74.
- Waldrop, J., Ciraulo, D. L., Milner, T. P., Gregori, D., Kendrick, A. S., Richart, C. M., et al. (2005). A comparison of continuous renal replacement therapy to intermittent dialysis in the management of renal insufficiency in the acutely ill surgical patient. *The American Surgeon*, 71(1), 36-39.
- Wan, L., Bellomo, R., Giantomasso, D. D., & Ronco, C. (2003). The pathogenesis of septic acute renal failure. *Current Opinion in Critical Care*, 9, 496-502.

- Waniewski, J. (2006). Mathematical modeling of fluid and solute transport in hemodialysis and peritoneal dialysis. *Journal of Membrane Science*, 274, 24-37.
- Ward, D. M., & Mehta, R. L. (1993). Extracorporeal management of acute renal failure patients at high risk of bleeding. *Kidney International*, 43(Suppl. 41), S237-S244.
- Warkentin, T. E., Levine, M. N., Hirsh, J., Horsewood, P., Roberts, R. S., Gent, M., et al. (1995). Heparin-induced thrombocytopenia in patients treated with low-molecular-weight heparin or unfractionated heparin. *New England Journal of Medicine*, 332(20), 1330-1335.
- Webb, A. R., Mythen, M. G., Jacobson, D., & Mackie, I. J. (1995). Maintaining blood flow in the extracorporeal circuit: haemostasis and anticoagulation. *Intensive Care Medicine*, 21, 84-93.
- Wendon, J., Smithies, M., Sheppard, M., Bullen, K., Tinker, J., & Bihari, D. (1989). Continuous high volume venous-venous haemofiltration in acute renal failure. *Intensive Care Medicine*, 15, 358-363.
- Wester, J. P. J. (2004). Guidelines for anticoagulation with danaparoid sodium and lepirudin in continuous venovenous hemofiltration. *Netherlands Journal of Critical Care*, 8(4), 293-301.
- Wiedemann, H. P., Wheeler, A. P., Bernard, G. R., Thompson, B. T., Hayden, D., deBoisblanc, B., et al. (2006). Comparison of Two Fluid-Management Strategies in Acute Lung Injury. *New England Journal of Medicine*, 354(24), 2564-2575.
- Wright, S. E., Bodenham, A., Short, A. I. K., & Turney, J. H. (2003). The provision and practice of renal replacement therapy on adult intensive care units in the United Kingdom. *Anaesthesia*, 58, 1063-1069.
- Ympa, Y. P., Sakr, Y., Reinhart, K., & Vincent, J.-L. (2005). Has mortality from acute renal failure decreased? A systematic review of the literature. *The American Journal of Medicine*, 118(8), 827-832.
- Yucha, C. (2004). Renal regulation of acid-base balance. *Nephrology Nursing Journal*, 31(2), 201-206.
- Yucha, C., & Guthrie, D. (2003). Renal Homeostasis of Calcium. *Nephrology Nursing Journal*, 30(6), 621-626.

APPENDIX A

MATERIAL SOURCED FOR THE LITERATURE REVIEW

Review Articles

Abbenbroek, B., Baldwin, I., Boyle, M., Foster, M., Hunt, T., Leslie, G. D., et al. (2004). Nursing Guidelines for the use of Xigris (drotrecogin alfa [activated] rhu). Printed by Lilly.

Abramson, S., & Niles, J. L. (1999). Anticoagulation in continuous renal replacement therapy. *Current Opinion in Nephrology and Hypertension*, 8, 701-707.

Abuclo, J., Shemin, D., & Chazan, J. (1993). Acute symptoms produced by haemodialysis: A review of their causes and associations. *Seminars in Dialysis*, 6, 59-69.

Abuelo, J. G. (2007). Normotensive Ischemic Acute Renal Failure Current Concepts. *The New England Journal of Medicine*, 357(8), 797-805.

Ahern-Gould, K., & Stark, J. (1998). Quick resource for electrolyte imbalance. *Critical Care Nursing Clinics of North America*, 10(4), 477-490.

Antoun, T. A., & Palevsky, P. M. (2009). Selection of Modality of Renal Replacement Therapy. *Seminars in Dialysis*, 22(2), 108-113.

Aucella, F., Paolo, S. D., & Gesualdo, L. (2007). Dialysate and Replacement Fluid Composition for CRRT. *Contributions to Nephrology*, 156, 287-296.

Baldwin, I. (2007). Factors Affecting Circuit Patency and Filter 'Life'. *Contributions to Nephrology*, 156, 178-184.

Baldwin, I., & Bellomo, R. (2004). Relationship between Blood Flow, Access Catheter and Circuit Failure during CRRT: A Practical Review. *Contributions to Nephrology*, 144, 203-213.

Bellomo, R., & Ronco, C. (1999). Renal replacement therapy in the intensive care unit. *Critical Care and Resuscitation*, 1, 13-24.

- Bellomo, R., & Ronco, C. (2000). Continuous haemofiltration in the intensive care unit. [Review]. *Critical Care*, 4(6), 339-345.
- Bosch, X., Poch, E., & Grau, J. M. (2009). Rhabdomyolysis and Acute Kidney Injury. *New England Journal of Medicine*, 361, 62-72.
- Bugge, J. F. (2004). Influence of renal replacement therapy on pharmacokinetics in critically ill patients. *Best Practice & Research Clinical Anaesthesiology*, 18(1), 175-187.
- Canaud, B., Leray-Moragues, H., Leblanc, M., Klouche, K., Vela, C., & Beraud, J. J. (1998). Temporary vascular access for extracorporeal renal replacement therapies in acute renal failure patients. *Kidney International*, 53(Suppl. 66), S142 - S150.
- Carr, J. A., & Silverman, N. (1999). The heparin-protamine interaction: A review. *Journal of Cardiovascular Surgery*, 40(5), 659-666.
- Chanard, J., Lavaud, S., Randoux, C., & Rieu, P. (2003). New insights in dialysis membrane biocompatibility: Relevance of adsorption properties and heparin binding. *Nephrology Dialysis and Transplantation*, 18, 252-257.
- Clark, W. R., & Ronco, C. (2001). Determinants of haemodialyser performance and the potential effect on clinical outcome. *Nephrology Dialysis Transplantation*, 16(5 Suppl.), 56-60.
- Clark, W. R., Turk, J. E., Kraus, M. A., & Gao, D. (2003). Dose determinants in continuous renal replacement therapy. *Artificial Organs*, 27(9), 815-820.
- Chong, B. H. (2003). Heparin-induced thrombocytopenia. *Journal of Thrombosis and Haemostasis*, 1, 1471-1478.
- Chrysochoou, G., Marcus, R. J., Sureshkumar, K. K., McGill, R. L., & Carlin, B. W. (2008). Renal Replacement Therapy in the Critical Care Unit. *Critical Care Nursing Quarterly*, 31(4), 282-290.
- Conger, J. D. (1990). Does hemodialysis delay recovery from acute renal failure? *Seminars in Dialysis*, 3(3), 146-148.
- Cruz, D., Bobek, I., Lentini, P., Soni, S., Chionh, C. Y., & Ronco, C. (2009). Machines for Continuous Renal Replacement Therapy. *Seminars in Dialysis*, 22(2), 123-132.

- Davenport, A. (1997). The coagulation system in the critically ill patient with acute renal failure and the effect of an extracorporeal circuit. *American Journal of Kidney Diseases*, 30(5 Suppl 4), S20-S27.
- Davenport, A. (2004). Anticoagulation for continuous renal replacement therapy. *Contributions to Nephrology*, 144, 228-238.
- Davenport, A. (2004). Heparin-induced thrombocytopenia during renal replacement therapy. *Hemodialysis International*, 8, 295-303.
- Davenport, A., & Tolwani, A. J. (2009). Citrate anticoagulation for continuous renal replacement therapy (CRRT) in patients with acute kidney injury admitted to the intensive care unit. *NDT Plus*, 2(6), 439-447.
- Davies, H., Morgan, D., & Leslie, G. (2008). A regional citrate anticoagulation protocol for pre-dilutional CVVHDF: The 'Modified Alabama Protocol'. *Australian Critical Care*, 21(3), 154-165.
- Dhondt, A., van Holder, R., van Biesen, W., & Lameire, N. (2000). The removal of uremic toxins. *Kidney International*, 58(Suppl 76), S47-S59.
- Dirkes, S. M. (2000). Continuous renal replacement therapy: Dialytic therapy for acute renal failure in intensive care. *Nephrology Nursing Journal*, 27(6), 581-590.
- Dirkes, S. M., & Hodge, K. (2007). Continuous renal replacement therapy in the adult intensive care unit: History and current trends. *Critical Care Nurse*, 27(2), 61-80.
- Hakim, R. M. (1993). Hemodialysis membrane biocompatibility. *Kidney International*, 44, 484-494.
- Heering, P., Grabensee, B., & Brause, M. (2003). Cytokine removal in septic patients with continuous venovenous hemofiltration. *Kidney & Blood Pressure Research*, 26, 128-134.
- Hoenich, N. A. (2007). Membranes and Filters for Haemodiafiltration. *Contributions to Nephrology*, 158, 57-67.
- Horrow, J. C. (1985). Protamine: A review of its toxicity. *Anesthesia and Analgesia*, 64, 348-361.

- Huang, Z., Gao, D., Letteri, J. J., & Clark, W. R. (2009). Blood-Membrane Interactions During Dialysis. *Seminars in Dialysis*, 22(6), 623-628.
- Joannidis, M., & Oudemans-Van Straaten, H. M. (2007). Clinical review: Patency of the circuit in continuous renal replacement therapy. *Critical Care*, 11(4), 218-227.
- John, S., & Eckardt, K.-U. (2007). Renal Replacement Strategies in the ICU. *Chest*, 132(4), 1379-1388.
- Johnston, R. V., Boiteau, P., Charlebois, K., Long, S., & David, U. (2004). Responding to tragic error: Lessons from Foothills Medical Centre. *Canadian Medical Association Journal*, 170(11), 1659-1660.
- Jones, C. H. (1998). Continuous renal replacement therapy in acute renal failure: Membranes for CRRT. *Artificial Organs*, 22(1), 2-7.
- Judson, J. A., & Fisher, M. (2006). Intensive Care in Australia and New Zealand. *Critical Care Clinics*, 22, 407-423.
- Kaplow, R., & Barry, R. (2002). Continuous Renal Replacement Therapies. *American Journal of Nursing*, 102(11), 26-33.
- Kelley, K. T. (2004). How Peritoneal Dialysis Works. *Nephrology Nursing Journal*, 31(5), 481-489.
- Kemp, H. J., Parnham, A., & Tomson, C. R. (2001). Urea kinetic modelling: A measure of dialysis adequacy. *Annals of Clinical Biochemistry*, 38, 20-27.
- Kirby, S., & Davenport, A. (1996). Haemofiltration/dialysis treatment in patients with acute renal failure. *Care of the Critically Ill*, 12(2), 54-56.
- Klenzak, J., & Himmelfarb, J. (2005). Sepsis and the kidney. *Critical Care Clinics*, 21, 211-222.
- Lameire, N., van Biesen, W., van Holder, R., & Colardyn, F. A. (1998). The place of intermittent hemodialysis in the treatment of acute renal failure in the ICU patient. *Kidney International*, 53(Suppl 66), S110-119.
- Leverve, X., & Barnoud, D. (1998). Stress metabolism and nutritional support in acute renal failure. *Kidney International*, 53(Suppl 66), S62-S66.

- Leypoldt. (2000). Solute fluxes in different treatment modalities. *Nephrology Dialysis Transplantation*, 15(Suppl 1), 3-9.
- Leunissen, K. M. L., & van Hooff, J. P. (1988). Acetate or bicarbonate for haemodialysis ? *Nephrology Dialysis Transplantation*, 3, 1-7.
- Ludlow, M. (2003). Renal Handling of Potassium. *Nephrology Nursing Journal*, 30(5), 493-497.
- Macias, W. L., & Clark, W. R. (1996). Acid-Base Balance in Continuous Renal Replacement Therapy. *Seminars in Dialysis*, 9(2), 145-151.
- Manns, M., Sigler, M. H., & Teehan, B. P. (1997). Intradialytic renal haemodynamics - potential consequences for the management of the patient with acute renal failure. *Nephrology Dialysis Transplantation*, 12, 870-873.
- Marshall, M. R., Golper, T., Shaver, M. J., & Chatoth, D. K. (2001). Hybrid renal replacement modalities for the critically ill. *Contributions to Nephrology*, 132, 252-257.
- Mehta, R. L. (1996). Anticoagulation strategies for continuous renal replacement therapies: What works? *American Journal of Kidney Diseases*, 28(5 Suppl 3), S8-S14.
- Mehta, R. L., Dobos, G. J., & Ward, D. M. (1992). Anticoagulation in continuous renal replacement procedures. *Seminars in Dialysis*, 5(1), 61-68.
- Misra, M. (2008). Basic mechanisms governing solute and fluid transport in hemodialysis. *Hemodialysis International*, 12, S25-S28.
- Moran, T. A., & Viele, C. S. (2005). Normal Clotting. *Seminars in Oncology Nursing*, 21(4), 1-11.
- Naka, T., & Bellomo, R. (2004). Bench-to-bedside review: Treating acid-base abnormalities in the intensive care unit - the role of renal replacement therapy. *Critical Care*, 8(2), 108-114.
- Oliver, M. J. (2001). Acute Dialysis Catheters. *Seminars in Dialysis*, 14(6), 432-435.
- O'Reilly, P., & Tolwani, A. J. (2005). Renal Replacement Therapy III: IHD, CRRT, SLED. *Critical Care Clinics*, 21, 367-378.

- Oudemans-van Straaten, H. M., Wester, J. P. J., de Pont, A. C. J. M., & Schetz, M. (2006). Anticoagulation strategies in continuous renal replacement therapy: Can the choice be evidence based? [Review]. *Intensive Care Medicine*, *32*, 188-202.
- Pastan, S., & Bailey, J. (1998). Dialysis Therapy. *New England Journal of Medicine*, *338*(20), 1428-1437.
- Riegel, W. (2003). Continuous renal replacement therapy in acute renal failure. *Kidney & Blood Pressure Research*, *26*, 123-127.
- Ricci, Z., & Ronco, C. (2008). Dose and efficiency of renal replacement therapy: Continuous renal replacement therapy versus intermittent hemodialysis versus slow extended daily dialysis. *Critical Care Medicine*, *36*(4), S229-S237.
- Ricci, Z., Bonello, M., Salvatori, G., Ratanarat, R., Brendolan, A., Dan, M., et al. (2004). Continuous renal replacement technology: From adaptive devices to flexible multipurpose machines. *Critical Care and Resuscitation*, *6*, 180-187.
- Ricci, Z., & Ronco, C. (2005). Renal Replacement II: Dialysis Dose. *Critical Care Clinics*, *21*, 357-366.
- Ronco, C., Brendolan, A., & Bellomo, R. (2001). Continuous Renal Replacement Techniques. *Contributions to Nephrology*, *132*, 236-251.
- Ronco, C., Crepaldi, C., Brendolan, A., Bragantini, L., D'Intini, V., Inguaggiato, P., et al. (2003). Evolution of synthetic membranes for blood purification: The case of the polyflux family. *Nephrology Dialysis Transplantation*, *18*(Suppl. 7), vii10-vii20.
- Ronco, C., & Levin, N. (2005). Mechanisms of solute transport in extracorporeal therapies. *Contributions to Nephrology*, *149*, 10-17.
- Ronco, C., Ricci, Z., Bellomo, R., & Bedogni, F. (2001). Extracorporeal ultrafiltration for the treatment of overhydration and congestive heart failure. *Cardiology*, *96*, 155-168.
- Ronco, C., Bellomo, R., & Ricci, Z. (2001). Continuous renal replacement therapy in critically ill patients. *Nephrology Dialysis Transplantation*, *16*(Suppl5), 67-72.
- Sakai, K. (2000). Dialysis membranes for blood purification. *Frontiers of Medical and Biological Engineering*, *10*(2), 117-129.

- Sarkar, S. (2009). Continuous Renal Replacement Therapy (CRRT). *The Internet Journal of Anesthesiology*, 21(1).
- Scheeren, T., & Radermacher, P. (1997). Prostacyclin (PG12): New aspects of an old substance in the treatment of critically ill patients. *Intensive Care Medicine*, 23, 146-158.
- Schetz, M. (2001). Anticoagulation for continuous renal replacement therapy. *Current Opinion in Anaesthesiology*, 14, 143-149.
- Schetz, M., Leblanc, M., & Murray, P. (2002). The Acute Dialysis Quality Initiative-part VII: Fluid composition and management in CRRT. *Advances in Renal Replacement Therapy*, 9(4), 282-289.
- Schetz, M. (2004). Should we use diuretics in acute renal failure? *Best Practice & Research Clinical Anaesthesiology*, 18(1), 75-89.
- Schrier, R. W. (2006). Role of diminished renal function in cardiovascular mortality. *Journal of the American College of Cardiology*, 47(1), 1-8.
- Shulman, R. I., Singer, M., & Rock, J. (2002). Keeping the circuit open: Lessons from the lab. *Blood Purification*, 20, 275-281.
- Sigler, M. H., & Manns, M. (1996). Membranes and Devices Used in Continuous Renal Replacement Therapy. *Seminars in Dialysis*, 9(2), 98-106.
- Thomas, M. C., & Harris, D. C. H. (2002). Problems and advantages of continuous renal replacement therapy. *Nephrology*, 7(3), 110-114.
- Tolwani, A. J., & Wille, K. M. (2009). Anticoagulation for Continuous Renal Replacement Therapy. *Seminars in Dialysis*, 22(2), 141-145.
- Uldall, R. (1996). Vascular access for continuous renal replacement therapy. *Seminars in Dialysis*, 9(2), 93-97.
- van Biesen, W., Veys, N., & Vanholder, R. (2007). Intermittent Hemodialysis for Replacement Therapy in Intensive Care: New Evidence for Old Truths. *Contributions to Nephrology*, 156, 304-308.

- van Biesen, W., Vanholder, R., & Lameire, N. (2003). Dialysis strategies in critically ill acute renal failure patients. *Current Opinion in Critical Care*, 9, 491-495.
- van Holder, R., & de Smet, R. (1999). Pathophysiologic effects of uremic retention solutes. *Journal of the American Society of Nephology*, 10, 1815-1823.
- Vesely, T. M. (2003). Central Venous Catheter Tip Position: A Continuing Controversy. *Journal of Vascular and Interventional Radiology*, 14, 527-534.
- Waniewski, J. (2006). Mathematical modeling of fluid and solute transport in hemodialysis and peritoneal dialysis. *Journal of Membrane Science*, 274, 24-37.
- Webb, A. R., Mythen, M. G., Jacobson, D., & Mackie, I. J. (1995). Maintaining blood flow in the extracorporeal circuit: haemostasis and anticoagulation. *Intensive Care Medicine*, 21, 84-93.
- Wester, J. P. J. (2004). Guidelines for anticoagulation with danaparoid sodium and lepirudin in continuous venovenous hemofiltration. *Netherlands Journal of Critical Care*, 8(4), 293-301.

Meta-analyses

Bagshaw, S. M., Berthiaume, L. R., Delaney, A., & Bellomo, R. (2008). Continuous versus intermittent renal replacement therapy for critically ill patients with acute kidney injury: A meta-analysis. *Critical Care Medicine*, 36(2), 610-617.

Kellum, J. A., Angus, D. C., Johnson, J. P., Leblanc, M., Griffin, M., Ramakrishnan, N., et al. (2002). Continuous versus intermittent renal replacement therapy: a meta-analysis. *Intensive Care Medicine*, 28, 29-37.

Subramanian, S., Venkataraman, R., & Kellum, J. A. (2002). Influence of dialysis membranes on outcomes in acute renal failure: A meta-analysis. *Kidney International*, 62(5), 1819-1823.

Tonelli, M., Manns, B., & Feller-Kopman, D. (2002). Acute renal failure in the intensive care unit: a systematic review of the impact of dialytic modality on mortality and renal recovery. *American Journal of Kidney Diseases*, 40(5), 875-885.

Randomised Controlled Trials

Acute Renal Failure Trial Network. (2008). Intensity of Renal Support in Critically Ill Patients with Acute Kidney Injury. *The New England Journal of Medicine*, 359(1), 7-20.

Augustine, J. J., Sandy, D., Seifert, T. H., & Paganini, E. P. (2004). A randomized controlled trial comparing intermittent with continuous dialysis in patients with ARF. *American Journal of Kidney Diseases*, 44(6), 1000-1007.

Baldwin, I., Naka, T., Koch, B., Fealy, N., & Bellomo, R. (2007). A pilot randomised controlled comparison of continuous veno-venous haemofiltration and extended daily dialysis with filtration: Effect on small solutes and acid-base balance. *Intensive Care Medicine*, 33, 830-835.

Baldwin, I., Tan, H. K., Bridge, N., & Bellomo, R. (2002). Possible strategies to prolong circuit life during hemofiltration: Three controlled studies. *Renal Failure*, 24(6), 839-848.

Barenbrock, M., Hausberg, M., Matzkies, F., de la Motte, S., & Schaefer, R. M. (2000). Effects of bicarbonate- and lactate-buffered replacement fluids on cardiovascular outcome in CVVH patients. *Kidney International*, 58, 1751-1757.

Bouman, C. S. C., Oudemans-Van Straaten, H. M., Tijssen, J. G. P., Zandstra, D. F., & Kesecioglu, J. (2002). Effects of early high-volume continuous venovenous hemofiltration on survival and recovery of renal function in intensive care patients with acute renal failure: A prospective, randomized trial. *Critical Care Medicine*, 30(10), 2205-2211.

Cole, L., Bellomo, R., Hart, G., Journois, D., Davenport, P., Tipping, P., et al. (2002). A phase II randomized, controlled trial of continuous hemofiltration in sepsis. *Critical Care Medicine*, 30(1), 100-106.

Davenport, A., Will, E. J., & Davison, A. M. (1991). Continuous vs. intermittent forms of haemofiltration and/or diaysis in the management of acute renal failure in patients with defective cerebral autoregulation at risk of cerebral oedema. *Contributions to Nephrology*, 93, 225-233.

Dungen, H.-D., von Heymann, C., Ronco, C., Kox, W. J., & Spies, C. (2001). Renal replacement therapy: Physical properties of hollow fibres influence efficiency. *The International Journal of Artificial Organs*, 24(6), 357-366.

Farese, S., Jakob, S. M., Kalicki, R., Frey, F. J., & Uehlinger, D. E. (2009). Treatment of Acute Renal Failure in the Intensive Care Unit: Lower Costs by Intermittent Dialysis Than Continuous Venous Hemodiafiltration. *Artificial Organs*, 33(8), 634-640.

Fealy, N., Baldwin, I., Johnstone, M., Egi, M., & Bellomo, R. (2007). A pilot randomized controlled crossover study comparing regional heparinization to regional citrate anticoagulation for continuous venovenous hemofiltration. *The International Journal of Artificial Organs*, 30(4), 301-307.

Gastaldello, K., Melot, C., Kahn, R.-J., Vanherweghem, J.-L., Vincent, J.-L., & Tielemans, C. (2000). Comparison of cellulose diacetate and polysulfone membranes in the outcome of acute renal failure. A prospective randomized study. *Nephrology Dialysis Transplantation*, 15, 224-230.

Hein, O. V., von Heymann, C., Lipps, M., Ziemer, S., Ronco, C., Neumayer, H., et al. (2001). Hirudin versus heparin for anticoagulation in continuous renal replacement therapy. *Intensive Care Medicine*, 27, 673-679.

Hein, O. V., von Heymann, C., Diehl, T., Ziemer, S., Ronco, C., Morgera, S., et al. (2004). Intermittent hirudin versus continuous heparin for anticoagulation in continuous renal replacement therapy. *Renal Failure*, 26(3), 297-303.

Joannidis, M., Kountchew, J., Grote, A., Bellmann, R., Mayr, A., & Wiedermann, C. (2004). Unfractionated versus low-molecular-weight heparin (enoxaparin) for anticoagulation in CVVH (abstract). *Intensive Care Medicine*, 30, S155.

Jorres, A., Gahl, G. M., Dobis, C., Polenakovic, M. H., Cakalaroski, K., Rutkowski, B., et al. (1999). Haemodialysis-membrane biocompatibility and mortality of patients with dialysis-dependent acute renal failure: a prospective randomised multicentre trial. *The Lancet*, 354, 1337-1341.

- Kielstein, J. T., Kretschmer, U., Ernst, T., Hafer, C., Bahr, M. J., Haller, H., et al. (2004). Efficacy and cardiovascular tolerability of extended dialysis in critically ill patients: A randomised controlled study. *American Journal of Kidney Diseases*, 43(2), 342-349.
- Kozek-Langenecker, S. A., Kettner, S. C., Oismueller, C., Gonano, C., Speiser, W., & Zimpfer, M. (1998). Anticoagulation with prostaglandin E1 and unfractionated heparin during continuous venovenous hemofiltration. *Critical Care Medicine*, 26(7), 1208-1212.
- Kutsogiannis, D. J., Gibney, R. T., Stollery, D., & Gao, J. (2005). Regional citrate versus systemic heparin anticoagulation for continuous renal replacement in critically ill patients. *Kidney International*, 67, 2361-2367.
- Langenecker, S. A., Felfernig, M., Werba, A., Mueller, C. M., Chiari, A., & Zimpfer, M. (1994). Anticoagulation with prostacyclin and heparin during continuous venovenous hemofiltration. *Critical Care Medicine*, 22(11), 1774-1781.
- Leslie, G. D., Jacobs, I. G., & Clarke, G. M. (1996). Proximally delivered dilute heparin does not improve circuit life in continuous veno-venous haemodiafiltration. *Intensive Care Medicine*, 22, 1261-1264.
- Mehta, R. L., McDonald, B., Gabbai, F. B., Pahl, M., Pascual, M. T. A., Farkas, A., et al. (2001). A randomized clinical trial of continuous versus intermittent dialysis for acute renal failure. *Kidney International*, 60, 1154-1163.
- Misset, B., Timsit, J.-F., Chevret, S., Renaud, B., Tamion, F., & Carlet, J. (1996). A randomized cross-over comparison of the hemodynamic response to intermittent hemodialysis and continuous hemofiltration in ICU patients with acute renal failure. *Intensive Care Medicine*, 22, 742-746.
- Monchi, M., Berghmans, D., Ledoux, D., Canivet, J. L., Dubois, B., & Damas, P. (2004). Citrate vs. heparin for anticoagulation in continuous venovenous hemofiltration: a prospective randomized study. *Intensive Care Medicine*, 30, 260-265.
- Mueller, C., Buerkle, G., Buettner, H. J., Petersen, J., Perruchoud, A. P., Eriksson, U., et al. (2002). Prevention of Contrast Media-Associated Nephropathy. *Archives of Internal Medicine*, 162, 329-336.

- Parienti, J.-J., Thirion, M., Megarbane, B., Souweine, B., Ouchikhe, A., Polito, A., et al. (2008). Femoral vs Jugular Venous Catheterization and Risk of Nosocomial Events in Adults Requiring Acute Renal Replacement Therapy: A Randomized Controlled Trial. *Journal of the American Medical Association*, 299(20), 2413-2422.
- Phu, N. H., Hien, T. T., Mai, N. T. H., Chau, T. T. H., Chuong, L. V., Loc, P. P., et al. (2002). Hemofiltration and peritoneal dialysis in infection-associated acute renal failure in Vietnam. *New England Journal of Medicine*, 347(12), 895-902.
- Ponikvar, J. B., Rus, R. R., Kenda, R. B., Bren, A. F., & Ponikvar, R. (2001). Low-flux versus high-flux synthetic dialysis membrane in acute renal failure: Prospective randomized study. *Artificial Organs*, 25(12), 946-950.
- Prasad, G. V. R., Palevsky, P. M., Burr, R., Lesko, J. M., Gupta, B., & Greenberg, A. (2000). Factors affecting system clotting in continuous renal replacement therapy: results of a randomised, controlled trial. *Clinical Nephrology*, 53(1), 55-60.
- Reeves, J. H., Cumming, A. R., Gallagher, L., O'Brien, J. L., & Santamaria, J. D. (1999). A controlled trial of low-molecular-weight heparin (dalteparin) versus unfractionated heparin as anticoagulant during continuous venovenous hemodialysis with filtration. *Critical Care Medicine*, 27(10), 2224-2228.
- Reeves, J. H., Seal, P. F., Voss, A. L., & O'Connor, C. (1997). Albumin priming does not prolong hemofilter life. *American Society of Artificial Internal Organs Journal*, 43, 193-196.
- RENAL Replacement Therapy Study Investigators. (2009). Intensity of Continuous Renal-Replacement Therapy in Critically Ill Patients. *The New England Journal of Medicine*, 361(17), 1627-1638.
- Ronco, C., Bellomo, R., Homel, P., Brendolan, A., Maurizio, D., Piccinni, P., et al. (2000). Effects of different doses in continuous veno-venous haemofiltration on outcomes of acute renal failure: a prospective randomised trial. *The Lancet*, 356, 26-30.
- Saudan, P., Niederberger, M., de Seigneux, S., Romand, J., Pugin, J., Perneger, T., et al. (2006). Adding a dialysis dose to continuous hemofiltration increases survival in patients with acute renal failure. *Kidney International*, 70(7), 1312-1317.

- Schiffl, H., Lang, S. M., & Fischer, R. (2002). Daily hemodialysis and the outcome of acute renal failure. *The New England Journal of Medicine*, *346*(5), 305-310.
- Schiffl, H., Lang, S. M., Konig, A., Strasser, T., Haider, M. C., & Held, E. (1994). Biocompatible membranes in acute renal failure: prospective case-controlled study. *The Lancet*, *344*, 570-572.
- Storck, M., Hartl, H. W., Zimmerer, E., & Inthorn, D. (1991). Comparison of pump-driven and spontaneous continuous haemofiltration in postoperative acute renal failure. *Lancet*, *337*, 452-455.
- Uehlinger, D. E., Jakob, S. M., Ferrari, P., Eichelberger, M., Huynh-Do, U., Marti, H.-P., et al. (2005). Comparison of continuous and intermittent renal replacement therapy for acute renal failure. *Nephrology Dialysis Transplantation*, *20*, 1630-1637.
- van der Voort, P. H. J., Gerritsen, R. T., Kuiper, M. A., Egbers, P. H. M., Kingma, W. P., & Boerma, E. C. (2005). Filter run time in CVVH: Pre-versus Post-dilution and Nadroparin versus Regional Heparin-Protamine anticoagulation. *Blood Purification*, *23*, 175-180.
- Vinsonneau, C., Camus, C., Combes, A., Costa de Beauregard, M. A., Klouche, K., Boulain, T., et al. (2006). Continuous venovenous haemodiafiltration versus intermittent haemodialysis for acute renal failure in patients with multiple-organ dysfunction syndrome: a multicentre randomised trial. *Lancet*, *368*, 379-385.

Prospective Observational Studies

Atherikul, K., Schwab, S. J., & Conlon, P. J. (1998). Adequacy of haemodialysis with cuffed central-vein catheters. *Nephrology Dialysis Transplantation*, *13*, 745-749.

Bagshaw, S. M., Uchino, S., Bellomo, R., Morimatsu, H., Morgera, S., Schetz, M., et al. (2009). Timing of renal replacement therapy and clinical outcomes in critically ill patients with severe acute kidney injury. *Journal of Critical Care*, *24*, 129-140.

Bagshaw, S. M., Laupland, K. B., Boiteau, P. J. E., & Godinez-Luna, T. (2005). Is regional citrate superior to systemic heparin anticoagulation for continuous renal replacement therapy? A prospective observational study in an adult regional critical care system. *Journal of Critical Care*, *20*(2), 155-161.

Baldwin, I., Bellomo, R., & Koch, B. (2004). Blood flow reductions during continuous renal replacement therapy and circuit life. *Intensive Care Medicine*, *30*(11), 2074-2079.

Baldwin, I., Tan, H. K., Bridge, N., & Bellomo, R. (2000). A prospective study of thromboelastography (TEG) and filter life during continuous veno-venous hemofiltration. *Renal Failure*, *22*(3), 297-306.

Bellomo, R., Farmer, M., Wright, C., Parkin, G., & Boyce, N. (1995). Treatment of sepsis-associated severe acute renal failure with continuous hemodiafiltration: Clinical experience and comparison with conventional dialysis. *Blood Purification*, *13*, 246-254.

Bellomo, R., Tipping, P., & Boyce, N. (1993). Continuous veno-venous hemofiltration with dialysis removes cytokines from the circulation of septic patients. *Critical Care Medicine*, *21*(4), 522-526.

Bellomo, R., Teede, H., & Boyce, N. (1993). Anticoagulant regimens in acute continuous hemodiafiltration. *Intensive Care Medicine*, *19*, 329-332.

Bellomo, R., Parkin, G., Love, J., & Boyce, N. (1993). A Prospective Comparative Study of Continuous Arteriovenous Hemodiafiltration and Continuous Venovenous Hemodiafiltration in Critically Ill Patients. *American Journal of Kidney Diseases*, *21*(4), 400-404.

Berbec, A. N., & Richardson, R. M. A. (2006). Sustained low-efficiency dialysis in the ICU: Cost, anticoagulation and solute removal. *Kidney International*, *70*(5), 963-968.

- Boldt, J., Menges, T., Wollbruck, M., Sonnerborn, S., & Hempelmann, G. (1994). Continuous hemofiltration and platelet function in critically ill patients. *Critical Care Medicine*, 22(7), 1155-1160.
- Canaud, B., Mion, C., Arujo, A., N' Guyen, V. Q., Paleyrac, G., Hemmendinger, S., et al. (1988). Prostacyclin (Epoprostenol) as the sole antithrombotic agent in postdilutional hemofiltration. *Nephron*, 48, 206-212.
- Cardigan, R., McGloin, H., Mackie, I., Machin, S., & Singer, M. (1999). Activation of the tissue factor pathway occurs during continuous venovenous hemofiltration. *Kidney International*, 55, 1568-1574.
- Cointault, O., Kamar, N., Bories, P., Lavayssiere, L., Angles, O., Rostaing, L., et al. (2004). Regional citrate anticoagulation in continuous venovenous haemodiafiltration using commercial solutions. *Nephrology Dialysis Transplantation*, 19, 171-178.
- Coraim, F. I., & Wolner, E. (1995). Continuous hemofiltration for the failing heart. *New Horizons*, 3(4), 725-731.
- Dahaba, A. A., Elawady, G. A., Rehak, P. H., & List, W. F. (2002). Procalcitonin and proinflammatory cytokine clearance during continuous venovenous haemofiltration in septic patients. *Anaesthesia and Intensive Care*, 30(3), 269-274.
- Davenport, A., Will, E. J., & Davison, A. M. (1994). Comparison of the use of standard heparin and prostacyclin anticoagulation in spontaneous and pump-driven extracorporeal circuits in patients with combined acute renal and hepatic failure. *Nephron*, 66, 431-437.
- Davenport, A., Will, E. J., & Davison, A. M. (1990). Adverse effects of prostacyclin administered directly into patients with combined renal and respiratory failure prior to dialysis. *Intensive Care Medicine*, 16, 431-435.
- Davenport, A., Will, E. J., & Davison, A. M. (1990). Effect of the direction of dialysate flow on the efficiency of continuous arteriovenous haemodialysis. *Blood Purification*, 8, 329-336.

de Pont, A. C. J. M., Bouman, C. S. C., Jonge, E. d., Vroom, M. B., Buller, H. R., & Levi, M. (2003). Treatment with recombinant human activated protein C obviates additional anticoagulation during continuous venovenous hemofiltration in patients with severe sepsis. *Intensive Care Medicine*, 29(7), 1205.

de Pont, A. C. J. M., Oudemans-vanStraaten, H. M., Roozendaal, K. J., & Zandstra, D. F. (2000). Nadroparin versus dalteparin anticoagulation in high-volume continuous venovenous hemofiltration: a double blind, randomized, crossover study. *Critical Care Medicine*, 28, 421-425.

de Vriese, A. S., Colardyn, F. A., Philippe, J. J., Vanholder, R., de Sutter, J. H., & Lameire, N. (1999). Cytokine removal during continuous hemofiltration in septic patients. *Journal of the American Society of Nephology*, 10, 846-853.

DO-RE-MISStudyGroup. (2009). Delivered dose of renal replacement therapy and mortality in critically ill patients with acute kidney injury. *Critical Care*, 13(2), R57-R70.

Ejaz, A. A., Komorski, R. M., Ellis, G. H., & Munjal, S. (2007). Extracorporeal circuit pressure profiles during continuous venovenous haemofiltration. *Nursing in Critical Care*, 12(2), 81-85.

Evanson, J. A., Himmelfarb, J., Wingard, R. L., Knights, S., Shyr, Y., Schulman, G., et al. (1998). Prescribed Versus Delivered Dialysis in Acute Renal Failure Patients. *American Journal of Kidney Diseases*, 32(5), 731-738.

Fiaccadori, E., Maggiore, U., Rotelli, C., Minari, M., Melfa, L., Cappe, G., et al. (2002). Continuous haemofiltration in acute renal failure with prostacyclin as the sole anti-haemostatic agent. *Intensive Care Medicine*, 28, 586-593.

Fischer, K. G., van de Loo, A., & Bohler, J. (1999). Recombinant hirudin (lepirudin) as anticoagulant in intensive care patients treated with continuous hemodialysis. *Kidney International*, 56(Suppl. 72), S46-S50.

Frank, D., Farber, H., Lanzmich, R., Floege, J., & Kierdorf, H. (2002). In vitro studies on hirudin elimination by haemofiltration: comparison of three high-flux membranes. *Nephrology Dialysis Transplantation*, 17, 1957-1963.

- Geronemus, R., & Schneider, N. (1984). Continuous arteriovenous haemodialysis: a new modality for the treatment of acute renal failure. *Transactions of the American Society for Artificial Internal Organs*, 30, 610-613.
- Gretz, N., Quintel, M., Ragaller, M., Odenwalder, W., Bender, H. J., Rhomeiss, P., et al. (1995). Low dose heparinization for anticoagulation in intensive care patients on continuous hemofiltration. *Contributions to Nephrology*, 116, 130-135.
- Hakim, R. M., Wingard, R. L., & Parker, R. A. (1994). Effect of the dialysis membrane in the treatment of patients with acute renal failure. *The New England Journal of Medicine*, 331(20), 1338-1342.
- Heering, P., Ivens, K., Thumer, O., Morgera, S., Heintzen, M., Passlick-Deetjen, J., et al. (1999). The use of different buffers during continuous hemofiltration in critically ill patients with acute renal failure. *Intensive Care Medicine*, 25, 1244-1251.
- Heering, P., Morgera, S., Schmitz, F. J., Willers, R., Schultheiss, H. P., Strauer, B. E., et al. (1997). Cytokine removal and cardiovascular hemodynamics in septic patients with continuous venovenous hemofiltration. *Intensive Care Medicine*, 23, 288-296.
- Henderson, L. W., Besarab, A., Michaels, A., & Bluemle, L. W. J. (1967). Blood purification by ultrafiltration and fluid replacement (diafiltration). *Transactions of the American Society for Artificial Internal Organs*, 17, 216-221.
- Henderson, L. W., Ford, C. A., Colton, C. K., Bluemle, L. W. J., & Bixler, H. J. (1970). Uremic blood cleansing by diafiltration using a hollow fiber ultrafilter. *Transactions of the American Society for Artificial Internal Organs*, 16, 107-114.
- Henderson, L. W., Livoti, L. G., Ford, C. A., Kelly, A. B., & Lysaght, M. J. (1973). Clinical experience with intermittent hemodiafiltration. *Transactions of the American Society for Artificial Organs*, 19, 119-123.
- Hesselvik, J. F., Malm, J., Dahlback, B., & Blomback, M. (1991). Protein C, Protein S and C4b-Binding Protein in severe infection and septic shock. *Thrombosis and Haemostasis*, 65(2), 126-129.

- Himmelfarb, J., Rubin, N. T., Chandran, P., Parker, R. A., Wingard, R. L., & Hakim, R. M. (1998). A multicenter comparison of dialysis membranes in the treatment of acute renal failure requiring dialysis. *Journal of the American Society of Nephrology*, *9*, 257-266.
- Hofmann, R. M., Maloney, C., Ward, D. M., & Becker, B. N. (2002). A novel method for regional citrate anticoagulation in continuous venovenous hemofiltration (CVVHF). *Renal Failure*, *24*(3), 325-335.
- Holt, A. W., Bierer, P., Glover, P., Plummer, J. L., & Bersten, A. D. (2002). Conventional coagulation and thromboelastograph parameters and longevity of continuous renal replacement circuits. *Intensive Care Medicine*, *28*, 1649-1655.
- Holt, A. W., Bierer, P., Bersten, A. D., Bury, L. K., & Vedig, A. E. (1996). Continuous renal replacement therapy in critically ill patients: Monitoring circuit function. *Anaesthesia and Intensive Care*, *24*(4), 423-429.
- Kaplan, A. A., Longnecker, R. E., & Folkert, V. W. (1984). Continuous arteriovenous hemofiltration: A report of six month's experience. *Annals of Internal Medicine*, *100*, 358-367.
- Kern, H., Ziemer, S., & Kox, W. J. (1999). Bleeding after intermittent or continuous r-hirudin during CVVH. *Intensive Care Medicine*, *25*, 1311-1314.
- Klingel, R., Schaefer, M., Schwarting, A., Himmelsbach, F., Altes, U., Uhlenbusch-Korwer, I., et al. (2004). Comparative analysis of procoagulatory activity of haemodialysis, haemofiltration and haemodiafiltration with a polysulfone membrane (APS) and with different modes of enoxaparin anticoagulation. *Nephrology Dialysis Transplantation*, *19*, 164-170.
- Klouche, K., Cavadore, P., Portales, P., Clot, J., Canaud, B., & Beraud, J. J. (2002). Continuous veno-venous hemofiltration improves hemodynamics in septic shock without modifying TNF and IL6 plasma concentrations. *Journal of Nephrology*, *15*(2), 150-157.
- Kramer, P., Wigger, W., Rieger, J., Matthaei, D., & Scheler, F. (1977). Arteriovenous haemofiltration: a new and simple method for treatment of over-hydrated patients resistant to diuretics. *Klin Wochensh*, *55*, 1121-1122.

- Kramer, P., Kaufhold, G., Grone, H. J., Rieger, J., Matthaei, D., Stokke, T., et al. (1980). Management of anuric intensive-care patients with arterio-venous haemofiltration. *The International Journal of Artificial Organs*, 3, 225-230.
- Kramer, P., Bohler, J., Kehr, A., Grone, H. J., Schrader, J., Matthaei, D., et al. (1982). Intensive care potential of continuous arteriovenous hemofiltration. *Transactions of the American Society for Artificial Internal Organs*, 28, 28-32.
- Kumar, V. A., Craig, M., Depner, T. A., & Yeun, J. Y. (2000). Extended daily dialysis: A new approach to renal replacement for acute renal failure in the intensive care unit. *American Journal of Kidney Diseases*, 36(2), 294-300.
- Kutsogiannis, D. J., Mayers, I., Chin, W. D., & Gibney, R. T. (2000). Regional citrate anticoagulation in continuous veno-venous hemodiafiltration. *American Journal of Kidney Diseases*, 35(5), 802-811.
- Lauer, A., Saccaggi, A., Ronco, C., Belledonne, M., Glabman, S., & Bosch, J. (1983). Continuous arteriovenous haemofiltration in the critically ill patient: clinical use and operational characteristics. *Annals of Internal Medicine*, 99, 455-460.
- Lindhoff-Last, E., Betz, C., & Bauersachs, R. (2001). Use of a low-molecular-weight heparinoid (Danaparoid sodium) for continuous renal replacement therapy in intensive care patients. *Clinical and Applied Thrombosis/Hemostasis*, 7(4), 300-304.
- Marshall, M. R., Ma, T., Galler, D., Patrick, A., Rankin, N., & Williams, A. B. (2004). Sustained low-efficiency daily diafiltration (SLEDD-f) for critically ill patients requiring renal replacement therapy: towards an adequate therapy. *Nephrology Dialysis Transplantation*, 19, 877-884.
- Mehta, R. L., Mc Donald, B. R., Aguilar, M. M., & Ward, D. M. (1990). Regional citrate anticoagulation for continuous arteriovenous hemodialysis in critically ill patients. *Kidney International*, 38, 976-981.
- Mitchell, A., Daul, A. E., Beiderlinden, M., Schafers, R. F., Heemann, U., Kribben, A., et al. (2003). A new system for regional citrate anticoagulation in continuous venovenous hemodialysis (CVVHD). *Clinical Nephrology*, 59(2), 106-114.

- Metnitz, P. G. H., Krenn, C. G., Steltzer, H., Lang, T., Ploder, J., Lenz, K., et al. (2002). Effect of acute renal failure requiring renal replacement therapy on outcome in critically ill patients. *Critical Care Medicine*, 30(9), 2051-2058.
- Morabito, S., Guzzo, I., Solazzo, A., Muzi, L., Luciani, R., & Pierucci, A. (2003). Continuous renal replacement therapies: Anticoagulation in the critically ill at high risk of bleeding. *Journal of Nephrology*, 16, 566-571.
- Nagarik, A., Soni, S., Adikey, G., & Raman, A. (2010). Comparative study of anticoagulation versus saline flushes in continuous renal replacement therapy. *Saudi Journal of Kidney Diseases and Transplantation*, 21(3), 478.
- Naka, T., Egi, M., Bellomo, R., Cole, L., French, C., Botha, J., et al. (2005). Commercial low-citrate anticoagulation haemofiltration in high risk patients with frequent filter clotting. *Anaesthesia and Intensive Care*, 33(5), 601-608.
- Nowak, G., & Bucha, E. (1996). Quantitative determination of hirudin in blood and body fluids. *Seminars in Thrombosis and Hemostasis*, 22(2), 197-202.
- Nurmohamed, M. T., Berckmans, R. J., Morrien-Salomons, W. M., Berends, F., Hommes, D. W., Rijniere, J. J. M. M., et al. (1994). Monitoring anticoagulant therapy by activated partial thromboplastin time: Hirudin assessment. *Thrombosis and Haemostasis*, 72(5), 685-692.
- Olbricht, C., Mueller, H., Schurek, H. J., & Stolte, H. (1982). Treatment of acute renal failure in patients with multiple organ failure by continuous spontaneous hemofiltration. *Transactions of the American Society for Artificial Internal Organs*, 28, 33-37.
- Palsson, R., & Niles, J. L. (1999). Regional citrate anticoagulation in continuous venovenous hemofiltration in critically ill patients with a high risk of bleeding. *Kidney International*, 55, 1991-1997.
- Payen, D., Cornelle de Pont, A., Sakr, Y., Spies, C., Reinhart, K., & Vincent, J. L. (2008). A positive fluid balance is associated with a worse outcome in patients with acute renal failure. *Critical Care*, 12, R74-R80.
- Ponikvar, R., Kandus, A., Buturovic, J., & Kveder, R. (1991). Use of prostacyclin as the only anticoagulant during continuous venovenous hemofiltration. *Contributions to Nephrology*, 93, 218-220.

Potzsch, B., Madlener, K., Seelig, C., Riess, C. F., Greinacher, A., & Muller-Berghaus, G. (1997). Monitoring of r-hirudin anticoagulation during cardiopulmonary bypass: Assessment of the whole blood ecarin clotting time. *Thrombosis and Haemostasis*, 77(5), 920-925.

Ricci, Z., Ronco, C., Bachesoni, A., D'amico, G., Rossi, S., Alessandri, E., et al. (2006). Solute removal during continuous renal replacement therapy in critically ill patients: Convection versus diffusion. *Critical Care*, 10(2), R67-R73.

Roberts, M., & Winney, R. J. (1992). Errors in fluid balance with pump control of continuous hemodialysis. *The International Journal of Artificial Organs*, 15(2), 99-102.

Sakr, Y., Vincent, J.-L., Reinhart, K., Groeneveld, J., Michalopoulos, A., Sprung, C., et al. (2005). High tidal volume and positive fluid balance are associated with worse outcome in Acute Lung Injury. *Chest*, 128(5), 3098-3108.

Salmon, J., Cardigan, R., Mackie, I., Cohen, S. L., Machin, S., & Singer, M. (1997). Continuous venovenous haemofiltration using polyacrylonitrile filters does not activate contact system and intrinsic coagulation pathways. *Intensive Care Medicine*, 23, 38-43.

Sieffert, E., Mateo, J., Deligeon, N., & Payen, D. (1997). Continuous veno-venous hemofiltration (CVVH) using heparin-coated or non-heparin-coated membranes in critically ill patients (abstract). *Blood Purification*, 15, 125.

Stefanidis, I., Hagel, J., Frank, D., & Maurin, N. (1996). Hemostatic alterations during continuous venovenous hemofiltration in acute renal failure. *Clinical Nephrology*, 46(3), 199-205.

Tan, H. K., Baldwin, I., & Bellomo, R. (2000). Continuous veno-venous haemofiltration without anticoagulation in high-risk patients. *Intensive Care Medicine*, 26, 1652-1657.

Tan, H. K., Bridge, N., Baldwin, I., & Bellomo, R. (2002). An ex-vivo evaluation of vascular catheters for continuous hemofiltration. *Renal Failure*, 24(6), 755-762.

Tolwani, A. J., Prendergast, M. B., Speer, R. R., Stofan, B. S., & Wille, K. M. (2006). A practical citrate anticoagulation continuous venovenous hemodiafiltration protocol for metabolic control and high solute clearance. *Clinical Journal of the American Society of Nephrology*, 1(1), 79-87.

- Tolwani, A. J., Campbell, R. C., Schenk, M. B., Allon, M., & Warnock, D. G. (2001). Simplified citrate anticoagulation for continuous renal replacement therapy. *Kidney International*, 60, 370-374.
- Troyanov, S., Geadah, D., Ghannoum, M., Cardinal, J., & Leblanc, M. (2004). Phosphate addition to hemodiafiltration solutions during continuous renal replacement therapy. *Intensive Care Medicine*, 30, 1662-1665.
- Uchino, S., Doig, G. S., Bellomo, R., Morimatsu, H., Morgera, S., Schetz, M., et al. (2004). Diuretics and mortality in acute renal failure. *Critical Care Medicine*, 32(8), 1669-1677.
- Uchino, S., Kellum, J. A., Bellomo, R., Doig, G. S., Morimatsu, H., Morgera, S., et al. (2005). Beginning and Ending Supportive Therapy for the Kidney (B.E.S.T. Kidney) Investigators. Acute renal failure in critically ill patients. A multinational, multicenter study. *Journal of the American Medical Association*, 294(7), 813-818.
- Uchino, S., Fealy, N., Baldwin, I., Morimatsu, H., & Bellomo, R. (2004). Continuous venovenous hemofiltration without anticoagulation. *American Society of Artificial Internal Organs Journal*, 50, 76-80.
- Uchino, S., Fealy, N., Baldwin, I., Morimatsu, H., & Bellomo, R. (2003). Continuous is not continuous: the incidence and impact of circuit down-time on ureamic control during continuous veno-venous haemofiltration. *Intensive Care Medicine*, 29, 575-578.
- Uchino, S., Fealy, N., Baldwin, I., Morimatsu, H., & Bellomo, R. (2003). Pre-dilution versus Post-dilution during continuous veno-venous hemofiltration: impact on filter and azotemic control. *Nephron Clinical Practice*, 94, c94-c98.
- van de Wetering, J., Westendorp, R. G. J., van der Hoeven, J. G., Stolk, B., Feuth, J. D. M., & Chang, P. C. (1996). Heparin use in continuous renal replacement procedures: the struggle between filter coagulation and patient haemorrhage. *Journal of the American Society of Nephrology*, 7(1), 145-150.
- Vun, C. M., Evans, S., & Chong, B. H. (1996). Cross-reactivity study of low molecular weight heparins and heparinoid in heparin-induced thrombocytopenia. *Thrombosis Research*, 81(5), 525-532.

Ward, D. M., & Mehta, R. L. (1993). Extracorporeal management of acute renal failure patients at high risk of bleeding. *Kidney International*, 43(Suppl. 41), S237-S244.

Weiss, L., Danielson, B. G., Wikstrom, B., Hedstrand, U., & Wahlberg, J. (1989). Continuous arteriovenous hemofiltration in the treatment of 100 critically ill patients with acute renal failure: Report on clinical outcome and nutritional aspects. *Clinical Nephrology*, 31(4), 184-189.

Retrospective Observational Studies

Bellomo, R., Mansfield, D., Rumble, S., Shapiro, J., Parkin, G., & Boyce, N. (1992). Acute renal failure in critical illness: Conventional dialysis versus acute continuous hemodiafiltration. *American Society of Artificial Internal Organs Journal*, 38, M654-M657.

Gettings, L. G., Reynolds, H. N., & Scalea, T. (1999). Outcome in post-traumatic acute renal failure when continuous renal replacement therapy is applied early versus late. *Intensive Care Medicine*, 25, 805-813.

Kim, I. B., Fealy, N., Baldwin, I., & Bellomo, R. (2010). Premature Circuit Clotting due to Likely Mechanical Failure during Continuous Renal Replacement Therapy. *Blood Purification*, 30, 79-83.

Manns, B., Doig, C. J., Lee, H., Dean, S., Tonelli, M., Johnson, D., et al. (2003). Cost of acute renal failure requiring dialysis in the intensive care unit: Clinical and resource implications of renal recovery. *Critical Care Medicine*, 31(2), 449-455.

Martin, P. Y., Chevrolet, J. C., Suter, P., & Favre, H. (1994). Anticoagulation in patients treated by continuous venovenous hemofiltration: a retrospective study. *American Journal of Kidney Diseases*, 24, 806-812.

Morimatsu, H., Uchino, S., Bellomo, R., & Ronco, C. (2003). Continuous renal replacement therapy: Does technique influence electrolyte and bicarbonate control? *International Journal of Artificial Organs*, 26(4), 289-296.

Schortgen, F., Soubrier, N., Delclaux, C., Thuong, M., Girou, E., Brun-Buisson, C., et al. (2000). Hemodynamic tolerance of intermittent hemodialysis in critically ill patients. *American Journal of Respiratory and Critical Care Medicine*, 162, 197-202.

Thakar, C. V., Christianson, A., Freyberg, R., Almenoff, P., & Render, M. L. (2009). Incidence and outcomes of acute kidney injury in intensive care units: A Veterans Administration study. *Critical Care Medicine*, 37(9), 2552-2558.

Uchino, S., Bellomo, R., & Ronco, C. (2001). Intermittent versus continuous renal replacement therapy in the ICU: Impact on electrolyte and acid-base balance. *Intensive Care Medicine*, 27, 1037-1043.

van Bommel, E. F. H., Bouvy, N. D., So, K. L., Zietse, R., Vincent, H. H., Bruining, H. A., et al. (1995). Acute dialytic support for the critically ill: Intermittent hemodialysis versus continuous arteriovenous hemodiafiltration. *American Journal of Nephrology*, *15*, 192-200.

Venkataraman, R., Kellum, J. A., & Palevsky, P. M. (2002). Dosing Patterns for Continuous Renal Replacement Therapy at A Large Academic Medical Center in the United States. *Journal of Critical Care*, *17*(4), 246-250.

Surveys

Langford, S., Slivar, S., Tucker, S. M., & Bourbonnais, F. F. (2008). Exploring CRRT practices in ICU: A survey of Canadian hospitals. *Dynamics: Official Journal of the Canadian Association of Critical Care Nurses*, 19(1), 18-23.

Overberger, P., Pesacreta, M., & Palevsky, P. M. (2007). Management of renal replacement therapy in acute kidney injury: A survey of practitioner prescribing practices. *Clinical Journal of the American Society of Nephrology*, 2, 623-630.

RENAL Replacement Therapy Study Investigators. (2008). Renal replacement therapy for acute kidney injury in Australian and New Zealand intensive care units: A practice survey. *Critical Care and Resuscitation*, 10, 225-230.

Richardson, A., Reynolds, C., & Rodgers, R. (2006). Utilizing audit to evaluate improvements in continuous veno-venous haemofiltration practices in intensive therapy unit. *Nursing in Critical Care*, 11(4), 154-160.

Silvester, W., Bellomo, R., & Cole, L. (2001). Epidemiology, management and outcome of severe acute renal failure of critical illness in Australia. *Critical Care Medicine*, 29, 1910-1915.

Case Reports

Fletcher, J. J., Bergman, K., Feucht, E. C., & Blostein, P. (2009). Continuous Renal Replacement Therapy for Refractory Intracranial Hypertension. *Neurocritical Care, 11*, 101-105.

Ho, K. M. (2006). Hyperlactataemia induced by CVVHDF with low lactate bicarbonate-buffered solutions in patients with liver dysfunction. *Nephrology Dialysis Transplantation, 2006*, 1096-1099.

Quality Assurance Projects

Brooks, G. (2006). Potassium additive algorithm for use in continuous renal replacement therapy. *Nursing in Critical Care, 11*(6), 273-280.

Mehta, R. L., Kellum, J. A., Shah, S. V., Molitoris, B. A., Ronco, C., Warnock, D. G., et al. (2007). Acute kidney injury network: Report of an initiative to improve outcomes in acute kidney injury. *Critical Care, 11*(2), R31-R38.

Editorial/Viewpoints

Himmelfarb, J. (2007). Continuous dialysis is not superior to intermittent dialysis in acute kidney injury of the critically ill patient. *Nature Clinical Practice Nephrology, 3*(3), 120-121.

Palevsky, P. M. (2009). Renal Support in Acute Kidney Injury-How Much Is Enough? [Editorial]. *New England Journal of Medicine, 361*(17), 1699-1701.

Ronco, C., & Bellomo, R. (2007). Dialysis in Intensive Care Unit Patients with Acute Kidney Injury: Continuous Therapy is Superior. *Clinical Journal of the American Society of Nephrology, 2*, 597-600.

APPENDIX B

OUTPUT OF RANDOM NUMBERS

17/11/2004

www.randomizer.org/form

CVVH = 1

CVVHdf = 2

“Research Randomizer” results:

1 set of 150 non-unique numbers per set

Range: From 1 to 2 – unsorted

1	2	17	2	33	2	49	2	65	1	81	2
2	1	18	2	34	1	50	1	66	1	82	2
3	1	19	2	35	2	51	2	67	1	83	2
4	1	20	1	36	1	52	1	68	2	84	2
5	2	21	1	37	2	53	1	69	2	85	1
6	2	22	1	38	1	54	2	70	1	86	1
7	1	23	1	39	2	55	1	71	2	87	2
8	2	24	2	40	1	56	2	72	2	88	2
9	1	25	1	41	2	57	1	73	1	89	1
10	2	26	2	42	1	58	1	74	1	90	1
11	1	27	1	43	2	59	2	75	1	91	2
12	1	28	1	44	1	60	2	76	2	92	2
13	2	29	2	45	2	61	2	77	2	93	1
14	2	30	2	46	2	62	1	78	1	94	1
15	2	31	2	47	2	63	1	79	1	95	2
16	1	32	2	48	1	64	1	80	2	96	1

97	2	106	1	115	1	124	2	133	1	142	2
98	1	107	2	116	2	125	2	134	1	143	1
99	1	108	1	117	1	126	2	135	2	144	2
100	1	109	1	118	1	127	2	136	1	145	2
101	1	110	2	119	2	128	2	137	1	146	1
102	1	111	2	120	1	129	2	138	1	147	2
103	1	112	2	121	2	130	1	139	1	148	1
104	2	113	2	122	1	131	2	140	1	149	2
105	2	114	2	123	2	132	1	141	1	150	2

APPENDIX C

PATIENT CONSENT FORMS

A RANDOMISED COMPARATIVE CROSSOVER STUDY TO ASSESS THE AFFECT ON CIRCUIT LIFE OF VARYING PRE-DILUTION VOLUMES ASSOCIATED WITH CONTINUOUS VENO-VENOUS HAEMOFILTRATION (CVVH) AND CONTINUOUS VENO-VENOUS HAEMODIAFILTRATION (CVVHDF).

Principle Investigator: Hugh Davies, RN

Research Supervisors:

Dr Gavin Leslie, Associate Professor Critical Care Nursing, Royal Perth Hospital

Dr Steve Webb, Intensivist, Royal Perth Hospital

Information Sheet and Consent Form (Patient)

Trial Summary

You are being asked to participate in a study comprising patients who have been admitted to intensive care diagnosed with kidney failure. Kidney failure is a common complication of severe illness. The treatment for kidney failure in the intensive care setting is continuous renal replacement therapy (CRRT). One way of achieving this is the use of a haemofilter which acts as an artificial kidney. The removal of substances dissolved in blood and the management of body fluid volume can be achieved by using two types of CRRT: continuous veno-venous haemofiltration (CVVH) and continuous veno-venous haemodiafiltration (CVVHDF). Both techniques provide adequate treatment for kidney failure but differ in the way this is achieved. Standard therapy for kidney failure at Royal Perth Hospital ICU has been CVVHDF. We wish to evaluate CVVH, a treatment used in over 25% of Australian ICUs for its effect on the life of the haemofilter and blood circuit.

Although CRRT is described as a continuous treatment, stoppages in treatment usually occur due to circulating blood outside of the body through the artificial kidney. Other reasons include the need for procedures to be carried outside the ICU, such as

surgery or special x-rays. These stoppages can result in a delay in treatment because a new haemofilter and blood line has to be prepared. Should clotting of the system occur, the quality and quantity of renal replacement therapy that is delivered can be impaired. We wish to test whether one type of CRRT, either CVVH or CVVHDF, can reduce the down-time caused by premature clotting of the blood line. This study has been deemed to be a quality assurance exercise by the Ethics Committee at Royal Perth Hospital but has been cleared on ethical aspects by the chairman. It has also been approved by Edith Cowan University Ethics Committee.

Your Role In The Study

Once you consent you will be randomised to have a ‘fifty-fifty’ chance of initially receiving either CVVH or CVVHDF. You will alternate between these two techniques whilst treated for kidney failure. Blood samples will be taken as part of normal treatment, but no additional blood samples will be required. Should your kidneys recover whilst in ICU then CRRT will be stopped irrespective of technique used.

Risks Associated With The Study

The risks associated with blood lines, such as loss of blood through inadvertent disconnection of the circuit. Are no different with CVVH than they are with CVVHDF. While the two techniques differ in terms of fluid delivery there has been no demonstrated difference in the occurrence of problems or complications associated with the administration of CVVH or CVVHDF. Both treatments are delivered by a fully automated kidney replacement machine (the KimalTM CRRT machine). Monitoring of the machine’s performance and the patient’s progress is the same for both treatments. It is not proposed that there will be any difference in the drugs routinely used to stop blood clotting for either CVVH or CVVHDF. While nursing staff are experienced in the running of CVVHDF using the KimalTM, training and ongoing supervision will be given to highlight the differences for CVVH.

Voluntary Participation

Regardless of the differences in techniques used (CVVH or CVVHDF), other treatments prescribed for kidney failure are not affected by the study and individuals participating in the study will not be disadvantaged in anyway. Your participation in this study is entirely voluntary. You are free to refuse to give consent or can withdraw

consent at any time should you change your mind. Refusal to take part in, or subsequent withdrawal from the study, will have no adverse effects on your medical treatment. You will continue to receive appropriate intensive care treatment whether or not you give consent for participation in this study.

Further Information

If you require further information or have any questions about this study, please contact:

For enquiries in regards to the specifics or design of the study:

Hugh Davies PhD Student

RN, B.Nurs, Grad Dip Nurs (Intensive Care), MHM

Clinical Nurse, Intensive Care Unit, Royal Perth Hospital, Wellington Street,

PERTH WA 600

Phone 08 9224 2727

For enquiries in regards to ethical concerns of the study:

Clinical Professor J. A. Miller

Chairman of the Ethics Committee

Phone 08 9224 2244

If after reading this sheet you are interested in participating, you will be asked to sign a written statement agreeing to participation in the study.

**CONSENT TO PARTICIPATION IN A STUDY TO INVESTIGATE
THE AFFECT ON CIRCUIT LIFE OF VARYING PRE-DILUTION
VOLUMES ASSOCIATED WITH CONTINUOUS VENO-VENOUS
HAEMOFILTRATION (CVVH) AND CONTINUOUS VENO-
VENOUS HAEMODIAFILTRATION (CVVHDF).**

I,.....agree to participate in the above study and allow the researcher access to my medical records to collect data relevant to this project. I have read and understood the attached information sheet and I have retained a copy of the signed document. I have been given the opportunity to ask questions about the study by the investigator. I understand that I may withdraw from the study at any time without affecting any future medical treatment, or the treatment of the condition which is the subject of the trial.

Signed.....

Date.....

Signature of Investigator.....

Date.....

A RANDOMISED COMPARATIVE CROSSOVER STUDY TO ASSESS THE AFFECT ON CIRCUIT LIFE OF VARYING PRE-DILUTION VOLUMES ASSOCIATED WITH CONTINUOUS VENO-VENOUS HAEMOFILTRATION (CVVH) AND CONTINUOUS VENO-VENOUS HAEMODIAFILTRATION (CVVHDF).

Principle Investigator: Hugh Davies, RN

Research Supervisors:

Dr Gavin Leslie, Associate Professor Critical Care Nursing, Royal Perth Hospital

Dr Steve Webb, Intensivist, Royal Perth Hospital

Information Sheet and Consent Form (Next-of-Kin)

Trial Summary

You are being asked to agree to your relative's participation in a study comprising patients who have been admitted to intensive care diagnosed with kidney failure. Kidney failure is a common complication of severe illness. The treatment for kidney failure in the intensive care setting is continuous renal replacement therapy (CRRT). One way of achieving this is the use of a haemofilter which acts as an artificial kidney. The removal of substances dissolved in blood and the management of body fluid volume can be achieved by using two types of CRRT: continuous veno-venous haemofiltration (CVVH) and continuous veno-venous haemodiafiltration (CVVHDF). Both techniques provide adequate treatment for kidney failure but differ in the way this is achieved. Standard therapy for kidney failure at Royal Perth Hospital ICU has been CVVHDF. We wish to evaluate CVVH, a treatment used in over 25% of Australian ICUs for its effect on the life of the haemofilter and blood circuit.

Although CRRT is described as a continuous treatment, stoppages in treatment usually occur due to circulating blood outside of the body through the artificial kidney. Other reasons include the need for procedures to be carried outside the ICU, such as surgery or special x-rays. These stoppages can result in a delay in treatment because a new haemofilter and blood line has to be prepared. Should clotting of the system occur, the quality and quantity of renal replacement therapy that is delivered can be impaired. We wish to test whether one type of CRRT, either CVVH or CVVHDF, can reduce the

down-time caused by premature clotting of the blood line. This study has been deemed to be a quality assurance exercise by the Ethics Committee at Royal Perth Hospital but has been cleared on ethical aspects by the chairman. It has also been approved by Edith Cowan University Ethics Committee.

Your Relative's Role In The Study

Once consent for your relative's participation has been given, your relative will be randomised to have a 'fifty-fifty' chance of initially receiving either CVVH or CVVHDF. Your relative will then alternate between these two techniques whilst treated for kidney failure. Blood samples will be taken as part of normal treatment, but no additional blood samples will be required. Should your relative's kidneys recover whilst in ICU then CRRT will be stopped irrespective of technique used.

Risks Associated With The Study

The risks associated with blood lines, such as loss of blood through inadvertent disconnection of the circuit, are no different with CVVH than they are with CVVHDF. While the two techniques differ in terms of fluid delivery there has been no demonstrated difference in the occurrence of problems or complications associated with the administration of CVVH or CVVHDF. Both treatments are delivered by a fully automated kidney replacement machine (the KimalTM CRRT machine). Monitoring of the machine's performance and the patient's progress is the same for both treatments. It is not proposed that there will be any difference in the drugs routinely used to stop blood clotting for either CVVH or CVVHDF. While nursing staff are experienced in the running of CVVHDF using the KimalTM, training and ongoing supervision will be given to highlight the differences for CVVH.

Voluntary Participation

Regardless of the differences in techniques used (CVVH or CVVHDF), other treatments prescribed for kidney failure are not affected by the study and individuals participating in the study will not be disadvantaged in anyway. Your relative's participation in this study is entirely voluntary. You are free to refuse to give consent or can withdraw consent at any time should you change your mind. Refusal to take part in, or subsequent withdrawal from the study, will have no adverse effects on your relative's medical treatment. Your relative will continue to receive appropriate intensive care treatment whether or not you give consent for participation in this study.

Further Information

If you require further information or have any questions about this study, please contact:

For enquiries in regards to the specifics or design of the study:

Hugh Davies PhD Student

RN, B.Nurs, Grad Dip Nurs (Intensive Care), MHM

Clinical Nurse, Intensive Care Unit, Royal Perth Hospital, Wellington Street,

PERTH WA 600

Phone 08 9224 2727

For enquiries in regards to ethical concerns of the study:

Clinical Professor J. A. Miller

Chairman of the Ethics Committee

Phone 08 9224 2244

If after reading this sheet you permit your relative to participate, you will be asked to sign a written statement on their behalf agreeing to their participation in the study.

**CONSENT TO PARTICIPATION IN A STUDY TO INVESTIGATE
THE AFFECT ON CIRCUIT LIFE OF VARYING PRE-DILUTION
VOLUMES ASSOCIATED WITH CONTINUOUS VENO-VENOUS
HAEMOFILTRATION (CVVH) AND CONTINUOUS VENO-
VENOUS HAEMODIAFILTRATION (CVVHDF).**

I, agree for my relative to participate in the above study. I have read and understood the attached information sheet and I have retained a copy of the signed document. I have been given the opportunity to ask questions about the study by the investigator. I understand that I may withdraw my relative from the study at any time without affecting any future medical treatment, or the treatment of the condition which is the subject of the study.

Signed.....

Date.....

Relationship to patient.....

Signature of Investigator.....

Date.....