

## SOUNDSENSE: SONIFYING PYROELECTRIC SENSOR DATA FOR AN INTERACTIVE MEDIA EVENT

John E. Bower<sup>\*‡</sup>, Scott Lindroth<sup>‡</sup>, John Burchett<sup>†</sup>,  
Steven D. Feller<sup>†</sup>, David J. Brady<sup>†</sup>, Rachael Brady<sup>\*</sup>

<sup>\*</sup>Center for Computational Science, Engineering and Medicine

<sup>†</sup>Fitzpatrick Center for Photonics and Communications

<sup>‡</sup>Department of Music

Duke University,

Durham, NC 27708, USA

john.bower@duke.edu, scott.lindroth@duke.edu, johnb@ee.duke.edu,  
sfeller@ee.duke.edu, dbrady@duke.edu, rbrady@duke.edu

### ABSTRACT

Collaborations between artists, engineers, and scientists often occur when creating new media works. These interdisciplinary efforts must overcome the ideals and practical-limitations inherent in both artistic and research pursuits. In turn, successful projects may truly be greater than the sum of their parts, enabling each collaborator to gain insight into their own work. *soundSense*, a cooperative effort between engineers, composers, and other specialists, sonifies pyroelectric sensor data to create a novel interactive-media event. Signals generated by multiplexing pyroelectric detectors inform data-driven audio and visual displays articulating – in real-time – the presence and motion of individuals within the sensed space.

### 1. INTRODUCTION

The development of a sonification facilitates interaction within a rewarding intersection of disciplines. While a particular investigator may seek the input of an artist or musician to provide guidance in creating an information display, the opposite proves true as well: many artists embrace the allure of some data set as the basis of a new work. Often the goals of science and art are not mutually exclusive. This paper serves to document the *soundSense* event at Duke University during November, 2004. *soundSense* leverages ongoing work with computational sensors and human tracking, sonification, and music composition to create an aesthetically engaging public event which links crowd behaviour in a space to musical events.

#### 1.1. Background

Sonification may generally be described as the mapping of some absolute, quantitative data to qualitative, representational structures of sound. Numerous studies establish the validity of sonification as a useful – if not ideal – means of information display [1]. Successful implementations include intraoperative monitoring devices [2]. These displays allow the user to devote attention to various tasks while retaining awareness of the information display's content [3]. The non-speech aural material within a sonification tends to vary widely, from ambient "nature" sounds to more musical structures.

Sonification does not portend a novel or exclusive intersection of art and science. Historically, composers have employed quantitative extramusical devices as the basis of a piece: e.g., Belá Bartók's use of the Fibonacci sequence in numerous compositions, statistical models in the work of Iannis

Xenakis, or geophysical data values in Charles Dodge's *Earth's Magnetic Field*. Some recent projects engage extramusical material in ways that explicitly communicate features of those devices. Composer John Dunn and biologist Mary Ann Clark's collaboration, *Life Music*, uses amino acid sequences in DNA as the seed for a series of algorithmically generated compositions [4]. Marty Quinn's piece, *The Climate Symphony*, maps multi-dimensional data from historical climate models to various parameter spaces in the music [5]. Ocean buoy data serves as the basis for a successful series of sonifications by Bob L. Sturm [6,7]. These projects and many others initially motivated by artistic and intellectual curiosity have often proven revelatory even to scientists familiar with the source data [4,6].

In addition to using the well-defined data sets described above, many artists develop or use some means of real-time, dynamic data acquisition to enable human interaction within a work. The integration of sensing technologies and performing arts appears frequently in the literature. Technologies explored for these implementations include: photoelectric detectors (*Variations V* by John Cage and David Tudor in collaboration with the Merce Cunningham Dance Company, 1965), piezo-electric, flex, and other resistive sensors as found in Laetitia Sonami's *lady's glove* devices [8], video-based motion detection and tracking such as David Rokeby's *Very Nervous System* [9], as well as electromagnetic and ultrasonic tracking systems [10,11].

Many projects embrace sensing technologies as an extension of the performer, facilitating new expressive possibilities through the integration of performance modalities. These interactions may occur as a dancer's motions generate a musical accompaniment or when a musician or group of musicians play a virtual "meta-instrument." With such compelling expressive possibilities, many artists have chosen not to apply these technologies in a manner that upholds traditional ideas of performer/audience segregation. Tod Machover's *Brain Opera* and *Toy Symphony* depend upon audience participation in their performance; the audience interacts with custom devices ("hyperinstruments" that integrate various sensing technologies) to generate or control musical events. Ryan Ulyate and David Bianciardi's *Interactive Dance Club* at 1998's 25th ACM SIGGRAPH conference encouraged exhibit visitors to interactively control many elements of the club's audio and visual environment [12]. To this end Ulyate and Bianciardi create different interaction "zones" using photoelectric detectors, infrared cameras, infrared proximity sensors, manual interfaces, and other devices. Although the audience imparts some influence on Machover's compositions

and Ulyate's and Bianciardi's installation, controlling elements of the works' designs manage how and to what extent these interactions effect the overall work: a very composition-centric design.

The augmented reality environment is another paradigm for the exploitation of sensing technologies and information (audio) display. The LISTEN project created an augmented-audio environment for the "Macke Labor" exhibition at the Kunstmuseum Bonn (Germany) in October, 2003 [13]. Exhibition visitors wear motion-tracked, wireless headphones. As the visitors explore the exhibit, each receives independent, spatialised audio based upon his or her location and field of view. The audio program articulates relationships between Macke's work and the visitors' historical perspectives within the exhibit.

### 1.2. soundSense

A collaboration between the Fitzpatrick Center for Photonics and Communications, the Department of Music, and the Information Science + Information Studies program at Duke University, *soundSense* translates a vision of a physical environment into a musical space. The impetus for the event was the opening and dedication of the university's new Fitzpatrick Center for Interdisciplinary Engineering, Medicine, and Applied Sciences which houses the Fitzpatrick Center's photonics studio space. The photonics studio contains a network of dual-element pyroelectric sensors. This sensor network detects thermal patterns (body heat) created by the presence and motion of people in the room. Since the resultant data is not easily interpreted through visual or other means, sonifying the sensor data enables participants in the sensor-space to associate the generated music with details of their particular physical setting, including individuals' location and behaviour.

*soundSense's* auditory display creates several simultaneous data mappings from a one-dimensional interpretation of the sensor data. These mappings favor trend analysis over discreet point estimation, allowing listeners to detect continuous movement through a hierarchy of thresholded data states. Both substantive and qualitative changes in the auditory display signify a change in data state.

## 2. SYSTEM

### 2.1. Sensors

The Fitzpatrick Center's Duke Integrated Sensing & Processing (DISP) research group provided the sensors used in *soundSense*. DISP's research entails creating a network of pyroelectric sensors that determines both the location and characteristics of human subjects within a sensed space; these attributes are resolved by observing a subject's thermal imprint on the sensors over time. Each sensor consists of a dual-element pyroelectric detector which senses light in the infrared range – such as radiated body heat. Changes in this thermal imprint results in a corresponding change in the sensor's output voltage. A Fresnel lenslet array placed above the detector functions as a reference structure between the source and detection spaces. The reference structure allows the sensor to map multiple projections from the physical sensor environment to a single detector's focal plane. This multiplexing enables a more efficient system by expressing complex states with minimal data [14]. Eight of these detectors are arranged together as one



Figure 1. Prototype sensor node.

hardware unit; the resulting hardware is hereafter referred to as a sensor node (see Figure 1). Each sensor node contains an embedded microcontroller which performs analog to digital conversion on an amplified signal from each of the node's eight detectors. The sensor node packetizes and transmits this data over radio frequency to a receiving "master" node that collects data from multiple sensor nodes, aggregates the data, and makes it available to a workstation over a serial connection. The photonics studio currently contains eighteen sensor nodes attached to the ceiling that produce 144 discreet detection signals for analysis.

### 2.2. Data Topology

The *soundSense* installation relies upon a multi-tiered network of workstations to realize its constituent elements (see Figure 2). A ShuttleBox running Windows XP hosts the radio frequency receivers and acts as the sensor data server. An Apple G5 audio master node runs the sensor client program written in ObjectiveC; this client collects the sensor data, converts the data into OSC format [15], and makes it accessible to the SuperCollider-based sonification program running on the same machine [16]. The sensor client program performs a variety of signal processing routines to filter individual data samples, and also features a real-time implementation of the Isomap dimensionality-scaling algorithm for time-based analysis of high-dimensional sample vectors [17].

The SuperCollider code manages the interpretation and display of the sensor data. A SensorPlatform class within SuperCollider performs analysis on the sensor data and creates relevant metadata. This class also manages a data-dependency dictionary for each sensor node that allows specific analysis or sonification objects and functions to be registered to any independent data element. When this data element changes, its

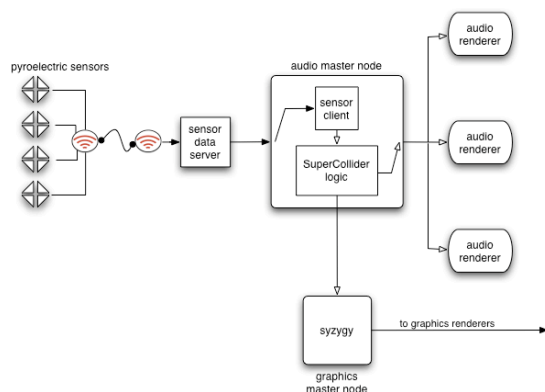

Figure 2. *soundSense* network topology.

registered dependent objects and functions are evaluated. Other classes manage synthesis routines and evaluate logic to determine spatial segmentation, localization, clustering, and other relevant information from the sensor data.

The audio master node's SuperCollider logic distributes OSC messages to the SuperCollider server application, scsynth. Three Apple G5 workstations each run two instances of scsynth. All scsynth audio computation occurs in a single thread; enabling two scsynth processes on each workstation allows full exploitation of the machine's multi-processing architecture. Parallel rendering discreet events in this manner allows easy expansion of processing resources. Although transmitting OSC over UDP introduces some network latency, the results are not at all objectionable in this implementation. In fact, the very slight timing variations may help "humanize" the "performance" of the audio. The rendering system's latency is roughly 10 ms, while the total system's latency varies from roughly 20 to 167 ms dependant upon sensor load and RF interference. Each of the three rendering computers contain an eight-channel capable audio interface. The signals of these three interfaces are mixed together and sent to an octaphonic speaker array that provides three-dimensional, free-field sound within the sensor space.

The sonification program also sends relevant metadata about the sensor space to a linux workstation. This workstation serves as a master node for the syzygy framework [18]. syzygy enables virtual-reality environments or display tiles to be distributed across clusters of commodity computers. The *soundSense* display space consists of forty-eight 19" led monitors deployed throughout the room (see Figure 3). A syzygy program interprets its received metadata and dynamically renders graphics and poetic text across the display tiles. The visual displays enhance the experience aesthetically and provide another modality of information display to correlate with the audio display.

### 3. SONIFICATION

Although *soundSense* involves mapping data in a presumably communicative form, any proven suitability of particular sounds for conveying data metrics was not considered. Instead, artistic desires determined the design of the particular synthesis instruments. These instruments were not insularly selected, however: the sonification designers relied upon formal training and experience as composers to create an instrumental palette with complimentary characteristics. This virtual ensemble creates aesthetically compelling sound spaces. The participant interprets the sensor data as displayed by the aggregate of these individual musical devices. Other work [19] suggests that good

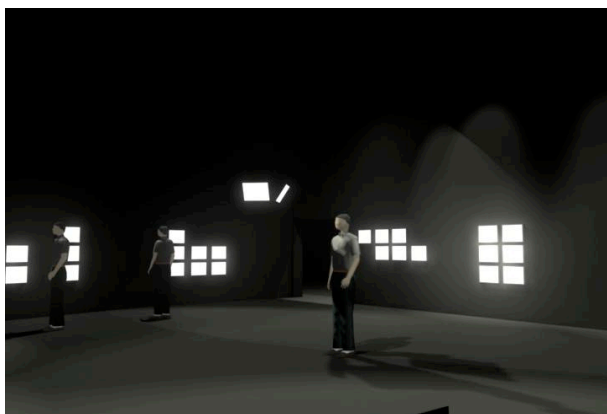

Figure 3. Rendering of the photonics studio.

orchestration technique should both facilitate and enhance the independent parsing of simultaneous display dimensions so long as timbre, spatial, registeral, temporal and other characteristics of any one component does not disrupt cognition of another. *soundSense's* instrumentation includes modeled percussion instruments (within the guise of a wind chime), a vocal choir, and a cello choir as well as a collection of more fantastic instruments.

#### 3.1. Sound Design

Many of the synthesis designs in *soundSense* implement banded waveguide systems, including the "wind chime" percussion, bowed "vibraphone", phoneme synthesizer, and a general reverberation instrument. Based upon work by Perry Cook, Julius O. Smith, *et al* [20], a banded waveguide system qualitatively approximates the spectral response of a passively or impulsively excited vibrating system by modeling the propagation of waves around a particular spatial mode. The excitation feeds into a bank of second-order Butterworth bandpass filters coupled to linearly-interpolating digital delays (see Figure 4). Each delay is tuned to a particular resonant mode of the sound; the number of samples to delay the signal is determined by multiplying the reciprocal of a modal frequency by the sample rate of the system. The output of the filter bank is summed and fed-back into the system at some wave impedance. The bandpass filters reject neighboring resonant modes created by the signal recursion's comb-response. Each bandpass filter's center frequency corresponds to the modal frequency of its coupled delay. An appropriately narrow filter bandwidth enables the rejection of any neighboring modes. Increasing the bandwidth of the bandpass filters changes the spectral response of the system due to the added "noise" around each modal frequency: an interesting feature for dynamically manipulating timbre.

Both the vocal choir and the cello choir employ granular synthesis techniques [21]. Granular synthesis creates a complex composite spectrum through a stream of discreet sonic events. Each event, or "grain", consists of a short waveform coupled to an amplitude envelope. These grains are brief events, usually between 1 and 100 milliseconds in duration. Streaming these grains – each with its own complex parameter space including but not limited to waveform, phase, transposition, envelope, duration, and amplitude – over time yields a rich sonic result.

The vocal choir in *soundSense* uses samples of a soprano singing sustained tones non-vibrato as the waveform sources for its granular stream. SuperCollider logic determines at what point in the sample-file to index, the nature of the grain's amplitude envelope, overall amplitude and duration of

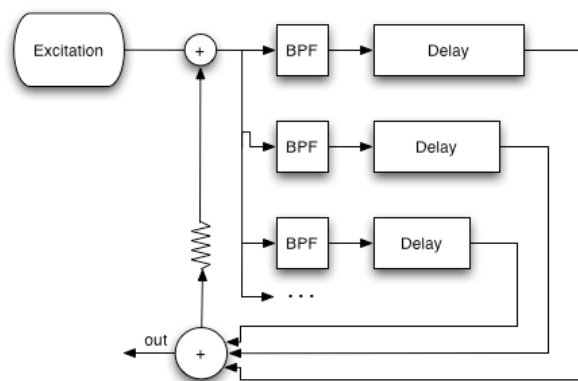

Figure 4. Simple banded waveguide signal flow.

each grain, as well as at what speed the file should be read – thereby effecting the transposition of the resulting grain. A richly diffuse choral sound emerges as the result of both slight variations in individual grain intonation and by processing the entire granular stream with some light phase-shifting and comb-delay. The cello choir is created in a similar fashion as the vocal choir, however its individual grain characteristics differ slightly from those of the vocal choir and its stream does not receive any phase shifting.

The remaining *soundSense* instruments emerge from much simpler synthesis methods. The FMsustain instrument does just that: it renders sustained tones generated by classic fm-synthesis techniques. This instrument features sinusoidal carrier and modulator tones which are dynamically modified over the note event's duration by logic in the SuperCollider sonification program. The resulting tone is then processed with phase shifting and a comb delay, the latter of which reinforces the instrument's timbral shifts. Simple sine tones provide low-frequency pitch-reinforcement within select contexts; these instantiations typically occur between 46 and 65 Hz (pitches F#1 and C).

### 3.2. Mappings

The *soundSense* sonification maps sensor data in two ways: directly and through a hierarchical superimposition of various musical layers. A thresholded measure of local and global sensor activity levels trigger these layers. The photonics studio features a tripartite division of space in order to articulate distinct regions of interest within the larger whole (see Figure 5). Examination of the sensor's raw voltage output determines when a person has entered the sensor's field of view. These output voltages are tracked over time and two sixth-order Kalman filters [22] are applied to the signal for noise reduction. This filtered signal indicates when a person moves into or out of a sensor's field of view creating three visibility states for each individual sensor: person entering (1), person leaving (-1), and no motion (0). To further simplify the data, the SuperCollider sonification program only considers the absolute value of the visibility state to determine whether a particular sensor currently detects motion. Pre-processing the output from each sensor node simplifies the data to an eight-dimensional vector of binary data. This data allows for the creation of measured activity levels within the overall space and – independently – each of the three sub-regions by examining the actual amount of registered motion versus the potential for detected motion over some delta of time. Since the absolute value of some activity level would likely be poorly perceived [23] in a direct mapping, the sonification program translates these values into one of several thresholded activity levels which should facilitate easier determination [3]. No sound occurs when the sensors do not register any activity.

The instrumental "wind chime" percussion is driven through a direct mapping of the sensor data. The wind chime metaphor serves to express a tangible and familiar parallel to the movement of people and their thermal signatures within the space. A single instance of the wind chime instrument exists for every sensor node in the studio space. The detection of motion by any sensor within that node creates a short note event ( $\approx 0.5$  seconds) by the appropriate wind chime. Spatialising each wind chime in a manner that corresponds to the physical location of its reciprocal sensor node helps the participant establish a sense of place and relativity within the space. No reverberation is applied to the wind chimes so as to not complicate identifying their spatial location [24].

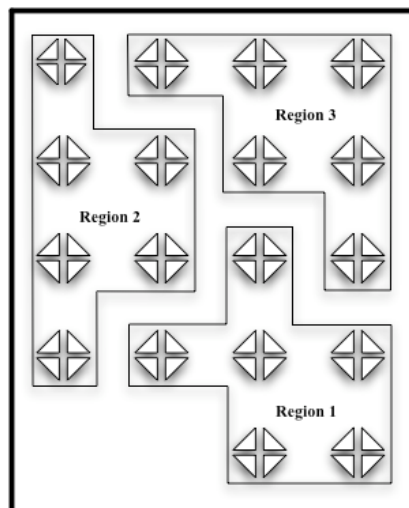

Figure 5. *The sensor space and its divisions.*

Although each instance of a wind chime note event communicates something about the state of the space, *soundSense* exploits the wind chimes more fully. The parameter space of the banded-waveguide construction allows for the transmission of multiple metrics by each wind chime. As such, each wind chime is considered within the context of its particular region in the larger sensed space. Each region features a unique set of modal frequencies upon which the wind chimes are based; this relates a region's spatial distinction to a basic timbral quality. The sonification program then uses the thresholded activity level within each region to modulate parameters of the region's wind chime instruments; these parameters include pitch, amplitude, resonance/timbre, and spatialisation (zenith). Table 1 shows how the wind chimes' parameters change in tandem with differing activity levels. A trial-and-error process determined the value of the thresholds that delineate each activity level; both the anticipated number of simultaneous participants and the desired responsiveness of the system informed these decisions. Table 1 also contextualizes the wind chime mappings within the greater sonification design.

Studies indicate that pitch change alone may not provide a reliable metric of data change [25]; independent modification of the wind chimes' non-pitch parameters may result in a similar lack of clarity. However, modifying all of these parameters in tandem monotonically emphasizes changes in a region's activity level. As activity increases within a region, the wind chimes "descend" into the space through modified panning along the vertical Y-axis. The increased amplitude and more resonant, brighter timbre reinforce the proximity effect. The pitch range of each wind chime also ascends in register allowing fuller articulation of the underlying musical harmony through a greater repertory of pitches; the presence of higher pitches may also convey a sense of urgency not present at lower activity levels [26]. The phoneme and FMsustain instruments provide subtle reinforcement of the underlying harmony during activity states two and three (as shown in Table 1). Both of these instruments are randomly spatialised within their respective regions and serve to possibly highlight a more active region during otherwise inactive periods.

The vocal choir and bowed "vibraphones" elucidate changes in the global activity level. Similar to the individual regions, the global sonification's particular characteristics depend upon a thresholded measure of the global activity level

level:	0	1	2	3	4	5	6	"exception"
<b>Regional Mappings</b>								
FMsustain & Phoneme	off			on		Off		
Wind Chimes	off	pch: 2; amp: 15%; res: 16.7%; zen: 85.8%	pch: 3; amp: 20%; res: 20%; zen: 71.6%	pch: 4; amp: 25%; res: 25%; zen: 57.4%	pch: 5; amp: 30%; res: 33%; zen: 43.2%	pch: 6; amp: 35%; res: 50%; zen: 29%	pch: 7; amp: 40%; res: 100%; zen: 14.8%	Off
<b>Global Mappings</b>								
Vocal Choir	off			soprano solo	soprano, alto	soprano, alto, tenor	soprano, alto, tenor, bass	Off
Bowed Vibraphones	off			soprano solo	soprano, alto	soprano, alto, tenor	soprano, alto, tenor, bass	Off
Cello Choir	off							On
Sine Tones	off							On
syzygy Graphics	off	behaviour one		behaviour two		behaviour three		behaviour four

Table 1. soundSense data mappings. Key: pch = pitch; amp = amplitude; res = resonance; zen = zenith;

within the sensor space. The vocal choir and bowed vibraphones are only present during four levels of global activity (Table 1) and each is presented within in its own area of the three-dimensional spatialised sound field. Unlike the wind chimes, changing activity levels do not modify the basic quality of these instruments; instead, their content changes in correlation to waxing and waning activity levels. When instantiated, the vocal choir chooses one of two isorhythmic patterns and acquires a randomly selected phrase from a dictionary of predefined melodies; this dictionary is keyed with the current harmony. Each melody, a cyclical structure of  $n$  pitches, is iterated with a random function which results in between  $n$  and  $n + 3$  note events per occurrence. The dictionary maintains the last pitch index for each melody. This index memory elides instantiations of the same melody type providing cohesion between events while avoiding repetition of the same melodic fragment. The bowed vibraphones work in a similar manner. The sonification program provides the same repertoire of melodies to the bowed vibraphones as to the vocal choir; however, the bowed vibraphone melodies are displaced two octaves lower in register and occur in a unique and constant isorhythm.

The sonification designers consciously chose not to encode data content within the melodies themselves. *soundSense* does not presume any user training prior to entering the exhibition space (however, a short animation and a textual description of the system are provided). Although training might enable participants to better recognize individual melodies and data states associated with them, other work that involves mapping data to melodic devices has proven discouraging for a general population [27,28]. Instead, the sonification program maps the global activity level within the sensor space in a manner more conducive to qualitative interpretation. The global activity level incrementally determines the number of voices performed by both the vocal choir and the bowed vibraphones – from a "soprano" line to full four-part harmony. This method allows for a perception of the content's "fullness" or richness, reinforced by a more concrete measure of greater polyphony and an expansion in register. Both the vocal choir and the bowed vibraphones self-manage

their polyphony, adding or removing voices – or turning themselves off completely – as the global activity level changes.

When the global activity level crosses a predefined threshold, an "exception" state occurs. This state serves metaphorically as an alarm, indicating a state of particular interest. The exception state features a relatively-fixed teleology and orchestration as the cello choir enters and cycles through the sonification's underlying harmonies in a faster harmonic rhythm. A percussion battery articulates these chords in a rhythmically distinct manner further emphasizing the novelty of the cello's appearance; sine tones reinforce the bass notes. The other global and regional mappings also become tacit in order to avoid aural conflicts during this state. The exception state, while intended to provide musical variety to the sonification, also informs the participant of a different state within the room: in this case a large amount of relatively rapid motion. The other global and regional mappings are re-instantiated once this state completes its course.

Within the sensor space, a sensor "kiosk" hangs from the ceiling. The kiosk consists of one sensor node – which the sonification system considers independent of the other sensor nodes – and four lcd displays which also have independence from the syzygy-based display tiles. The kiosk effectively acts as its own (fourth) local region: an instance of the wind chime instrument here only considers the data local to this sensor node; the wind chime also has a unique set of modal frequencies and other parameters to further distinguish it from other wind chime instruments in the space (beyond its spatialisation). The lcds provide visual feedback of this sensor node's excitation through four visualizations: an oscilloscope, parallel coordinate plotting, a star plot, and raw data streaming. The kiosk provides the participant a more accessible relationship with the technology in the space. Multiple modes of feedback (aural and visual) empower the participants to discover more about how their actions elicit a response from the system and therefore enable them to learn more about the space as a whole.

Finally, the sonification program controls elements of the visual feedback within the space. The program relays messages containing a thresholded representation of the global activity level to the syzygy master node (Table 1). The syzygy program responds by changing the content shown on the display

tiles. Each activity level has a corresponding and visually distinct display behaviour that distinguishes one level from another. These easily identifiable changes in display characteristics should readily correlate to simultaneous alterations in the sonification.

### 3.3. Composition

*soundSense* strives to provide a musical experience for a participant while simultaneously communicating information about the space with reticent immediacy. The musical structure's underlying foundation resembles the Baroque chaconne. A chaconne features melodic and contrapuntal variations on top of a static, repeating harmonic progression. This basic musical form creates stability through the familiarity of its conventions. The cyclical harmonic progression (see Figure 6) also enables the development of a sense of place within what may otherwise be an unfamiliar harmonic world. A slow harmonic rhythm – on the order of 45 - 60 seconds per harmony – allows the listener time to explore the quality of each sonority. Complex, non-functional harmonic structures appealed to the sonification's creators for their aesthetic qualities. However, they also serve a practical purpose as well. Preliminary work of ours that employs more functional tonal harmonies and quicker harmonic rhythm proved fatiguing to hear over long periods of time. Mapping data to tonal progressions – with their associative musical weight – may prove difficult to interpret while instilling possible listener fatigue due to a generated progression's possible conflict with well-conditioned musical expectations. Although unfamiliar harmonies may address these circumstantial issues of defeated musical assumptions, their recognition would likely prove much more difficult. Therefore no data is mapped to the harmonies.

The musical layers exist within their own temporal space through the use of isorhythms. An isorhythm periodically repeats a particular rhythmic pattern and is usually not limited to any specific melodic content. The vocal choir chooses between two isorhythms for each instance of a new melodic event. The bowed vibraphones appear in a characteristic rhythm of their own. This temporal separation helps to enable both recognition of textural polyphony and independent parsing of each musical stream. Although they are not periodic by design, the other instruments also make use of temporal separation through note events of a unique amplitude envelope and fixed duration. The phoneme and FMSustain instruments always occur as singular events characterized by a trapezoidal amplitude envelope and a duration of several seconds. The wind chimes' percussive nature and short duration further distinguish them from the other sounds. In fact, in an active room the wind chimes create an underlying pulse in the space. The radio frequency transmission of the sensor data limits the transmission rate to roughly 6 Hz. The wind chimes have a tendency to "quantize" to this rate as people move about the space and trigger the sensors. This effect helps establish



Figure 6. Chaconne harmonic progression.



Figure 7. Sample *soundSense* melody.

regularity within a musical texture that does not force its constituent events to adopt temporal quantization to a master clock or fundamental tempo.

The composition treats each harmony within the chaconne progression as a "key of the moment". The musical material which occurs during the tenure of each harmony pandiatonically explores that harmony's pitch collection. This treatment resembles commonly employed practices throughout the canon of most Western musics, from Claude Debussy to Miles Davis and beyond. Figure 7 presents an example of a *soundSense* melody that coincides with the first chaconne harmony's pitch collection. All the pitches within this four-part chorale correspond to those pitches in the first harmony with the exception of the D# leading-tone to the final E. The melodies that correspond to each of the first four harmonies are identical to each other except in their transpositions. The nature of the harmony allows this, since these four harmonies are merely reordered variations of a common, base structure. Musically, this characteristic helps enable another layer of form above that which the chaconne itself provides. The structurally similar material in the chaconne's first half creates a relative stasis compared to the more varied material in the progression's second half. This motion further enables a sense of propulsion through the music which is reinforced by oscillating Bb-C voice leading – doubled at the octave – within each half of the chaconne progression.

## 4. GENERAL DISCUSSION

*soundSense* shows both the potential of and reward from interdisciplinary collaborations within Duke. Composers, engineers, and computer scientists collectively realized a project that necessitated each collaborator to apply their expertise towards unfamiliar ends. The Duke University collaborators recognize the novel interactions that *soundSense* encouraged within their own institution. The DISP research group found *soundSense* useful since it presents a number of complex, time-varying data streams in a manner conducive to easy interpretation. One scientist comments that he now relies on the sonification to confirm the system's working order. The composers feel an equal degree of satisfaction from the challenge of composing an interesting yet unobtrusive foundation for the sonification.

The *soundSense* event was well received. Participants remarked on the evocative nature of the space and its aural and visual displays; for many, the experience provided a novel means for interaction with art and technology. The inclusion of the single sensor kiosk and accompanying visualizations enabled the participants to learn about aspects of detection and causality within the aggregate system. As such, people quickly recognize how their movements correspond to the rendered audio.

Although aural events in *soundSense* are data-driven, the underlying compositional conceits unify constituent events into a greater musical structure for the participants to discover. As participants learn about causality within the system, they may also begin to recognize elements of this musical structure. In turn, a sufficiently suggestive sound design encourages participants to purposefully "play the space", consciously moving in order to generate a "desired" musical state.

*soundSense* is musically evocative with rich and dynamic instrumentation. These sounds, in tandem with the chaconne progression and multiple isorhythmic layers, create an austere and quite beautiful musical space. These same qualities also create a sense of detachment in the music. Although not necessarily aesthetically undesirable, the time scales of different

isorhythmic devices – especially the vocal choir – could benefit from a deeper, more intimate connection with the transient ebb and flow of sensor activity levels. Overall, *soundSense* could apply a greater musical engagement with rhythmic causality in tandem with the textural one already present, should the data and accrued network latency enable this change. Furthermore, an expanded sonic palette might also allow a greater distinction between activity levels due to more dramatic changes in orchestration.

The sonification, while an effective information display, is not without its limitations. The computational sensors deployed for the event are prototypes, inchoate products of an ongoing and constantly evolving research endeavour. Substantial overlap of each sensor node's field of view impedes highly resolved interpretation of participant location. This lack of spatial resolution limits the sonification's effectiveness. The pyroelectric detectors require a change in the presence of thermal radiation to create a signal and thus effect the activity level. Large crowds saturate the detectors due to the sensors' large field of view: although motion is present, the detectors do not always detect this motion accurately. Therefore, *soundSense* is most effective with a smaller number of participants.

The one-dimensional sonification of activity levels proved to be a prudent design decision. Efficient algorithms for demultiplexing the sensor data were not available at the time of the event: therefore, higher level interpretations of the sensor data were not possible. As the sensor system matures, less rudimentary data will create more complex detections of the room state and the actions of the people within. Some available analytical methods (correlating/clustering excited sensors, the Isomap technique) are not exploited by *soundSense* due to issues of scalability and the amount of time available to "tune" the system before the event. Nevertheless, the thresholding of activity levels, spatial segmentation of the sensor field, and hierarchical superimposition of aural devices creates a meaningful mediation of the sensor data. The current lack of high spatial resolution also masks any perceivable system latency and further co-opts isolated events into the greater whole: an advantageous characteristic for the *soundSense* application.

The technologies around *soundSense* clearly offer promising opportunities for both auditory displays and artistic installations. More refined versions of the sensor nodes will enable better data acquisition from a sensed space. Future sonification work includes devising new mappings from the more sophisticated sensor data. We hope to conduct a user study to determine the tactical applicability of these mappings for recognizing the presence and behavior of – and interaction between – tracked individuals within the sensor space. Should a reprisal of the *soundSense* event occur, the interim research progress should enable a much more sophisticated level of interaction for the participants and a more substantial means of musical expression for the composers.

## 5. ACKNOWLEDGMENTS

The *soundSense* event exists only due to the tremendous effort of many people – far too many to list here. However, primary accolades need to be given to the Fitzpartick Center's David Brady and his entire DISP research group for creating the sensors and providing the space, DISP's Steve Feller for infrastructure and logistical support, John Bower and Scott Lindroth who co-wrote the music and designed the sonification, Joseph Donahue who provided the textual material, David Zielinski for the syzygy programming, and Casey Alt for the

flash animation and documentation. Additional thanks must go to members of the Information Science + Information Studies program, the Visualization Technology Group, and Duke's Center for Computational Science, Engineering, and Medicine.

## 6. REFERENCES

- [1] S. Bly, "Presenting Information in Sound," in *Proc. of the 1982 Conference on Human factors in Computing Systems*, 1982, pp. 371-375.
- [2] R. G. Loeb and W. T. Fitch, "A Laboratory Evaluation of an Auditory Display Designed to Enhance Intraoperative Monitoring," *Anesthesia & Analgesia*, vol. 94, pp. 362-368, 2002.
- [3] B. S. Mauney and B. N. Walker, "Creating Functional and Livable Soundscapes for Peripheral Monitoring of Dynamic Data," in *Proc. of the 2004 International Conference on Auditory Display*, Sydney, Australia, 2004.
- [4] J. Dunn and M. A. Clark, "Life Music: The Sonification of Proteins," *Leonardo*, vol. 32, no. 1, pp. 25-32, 1999.
- [5] M. Quinn and L. D. Meeker, "Research Set to Music: The Climate Symphony and Other Sonifications of Ice Core, Radar, DNA, Seismic and Solar Wind Data," in *Proc. of the 2001 International Conference on Auditory Display*, Espoo, Finland, 2001.
- [6] B. L. Sturm, "Surf Music: Sonification of Ocean Buoy Spectral Data," in *Proc. of the 2002 International Conference on Auditory Display*, Kyoto, Japan, 2002.
- [7] B. L. Sturm, "Ocean Buoy Spectral Data Sonification: Research Update," in *Proc. of the 2003 International Conference on Auditory Display*, Boston, MA, USA, 2003.
- [8] L. Sonami, "Lady's Glove," April 2005, <http://www.sonami.net>.
- [9] D. Rokeby, "The Very Nervous System," April 2005, <http://www.interlog.com/~drokeby/vns.html>.
- [10] R. Morales-Manzanares, E. F. Morales, R. Dannenberg and J. Berger, "SICIB: An Interactive Music Composition System Using Body Movements," *Computer Music Journal*, vol. 25, no. 2, pp. 25-37, 2001.
- [11] M. Reynolds, B. Schoner, J. Richards, K. Dobson and N. Gershenfeld, "An Immersive, Multi-User, Musical Stage Environment," *SIGGRAPH '01: Proc. of the 28th Annual Conference on Computer Graphics and Interactive Technologies*, 2001, pp. 553-560.
- [12] R. Ulyate and D. Bianciardi, "The Interactive Dance Club: Avoiding Chaos in a Multi-Participant Environment," *Computer Music Journal*, vol. 26, no. 3, pp. 40-49, 2002.
- [13] J. Goßmann, "Connecting Virtual Sound and Physical Space in Audio-Augmented Environments," in *Proc. of the 2004 International Conference on Auditory Display*, Sydney, Australia, 2004.
- [14] U. Gopinathan, D. J. Brady and N. P. Pitsianis, "Coded apertures for efficient pyroelectric motion tracking," *Optics Express*, vol. 11, no. 18, pp. 2142-2152, 2003.
- [15] Center for New Music and Audio Technologies, University of California at Berkeley, "OpenSoundControl," April 2005, <http://www.cnmat.berkeley.edu/OpenSoundControl>.
- [16] "SuperCollider", April 2005, <http://supercollider.sourceforge.net>.
- [17] J. B. Tenenbaum, V. de Silva and J. C. Langford, "A Global Geometric Framework for Nonlinear Dimensionality Reduction," *Science*, vol. 290, no. 5500, 2319-2323, 2000.
- [18] Integrated Systems Laboratory, University of Illinois at Urbana-Champaign, "syzygy," <http://www.isl.uiuc.edu/syzygy.htm>.

- [19] C. Cullen and E. Coyle, "Orchestration within the Sonification of basic Data Sets," in *Proc. of the 2004 International Conference on Auditory Display*, Sydney, Australia, 2004.
- [20] G. Essl, S. Serafin, P. R. Cook and J. O. Smith, "Theory of Banded Waveguides," *Computer Music Journal*, vol. 28, no. 1, pp. 37-50, 2004.
- [21] C. Roads, *Microsound*. Cambridge: MIT Press, 2001.
- [22] University of North Carolina at Chapel Hill, "The Kalman Filter," April 2005, <http://www.cs.unc.edu/~welch/kalman>.
- [23] A. Sándor and D. M. Lane, "Sonification of Absolute Values With Single and Multiple Dimensions," in *Proc. of the 2003 International Conference on Auditory Display*, Boston, MA, USA, 2003.
- [24] S. Devore and B. Shinn-Cunningham, "Perceptual Consequences of Including Reverberation in Spatial Auditory Displays," in *Proc. of the 2003 International Conference on Auditory Display*, Boston, MA, USA, 2003.
- [25] J. G. Neuhoff, R. Knight and J. Wayand, "Pitch Change, Sonification, and Musical Expertise: Which Way Is Up?" in *Proc. of the 2002 International Conference on Auditory Display*, Kyoto, Japan, 2002.
- [26] J. Häkkinen and S. Ronkainen, "Dynamic Auditory Cues for Event Importance Level," in *Proc. of the 2003 International Conference on Auditory Display*, Boston, MA, USA, 2003.
- [27] F. L. Van Scoy, "Sonification of Remote Sensing Data: Initial Experiment," presented at Information Visualization 2000, London, UK, 2000.
- [28] G. Johannsen, "Auditory Displays in Human-Machine Interfaces," *Proc. of the IEEE*, Vol. 92, no. 4, pp. 742-758, 2004.