



Abstract

The security of oil transportation through pipeline grids is of paramount importance. One of the security methods currently used in this field is a monitoring and supervision system. This poster represents a proposal to blend Internet of Things (IoT) with artificial intelligence (AI) to create a knowledge-based system to monitor and supervise oil transportation through the pipeline grid. The reliability of IoT allows the user to gain lots of useful data to satisfy the needs, analyse health, gain the direction, achieve better communication and have a higher accuracy percentage [1]. In this research, the Internet of things were the pressure and volume sensors near the valves and pumps. Nowadays, AI has proven its effectiveness in many disciplines and therefore Neuro-Fuzzy (NF) [2] will be used as the prediction tool in the system.

The supervision system is developed in phases; three simulation systems should be produced. Phase one; a wired centralized supervision system, phase two; a wired decentralized supervision system and finally phase three; a wireless decentralized supervision system. The first phase showed promising results, while the work will continue with the other two phases.

Introduction

Oil companies and governments are investing in security to improve efficiency. The main factors of improvement can be: better quality of service, reduced losses in products and resources (such as equipment, devices and manpower) and reduced damage to the environment. Monitoring and supervision systems provide a better understanding of the transportation process, allowing appreciation of the transportation time required, better communication and lower financial losses. However, some established oil companies are already putting into practice advanced technologies to help better protect their oil transportation, but the search will continue to find advanced technologies that are more reliable and economical to implement. For example, oil pipeline leakages have harsh effects both environmentally and financially. Although, the financial effect may be catastrophic the environmental impact will be more long-term [3]. The search to find a methodology, technology, device or system which can reduce this impact is still on.

Research Aim

Apply an intelligent system (Fig. 1) in oil pipeline transportation grids to decrease environmental and financial losses whilst achieving better communication.

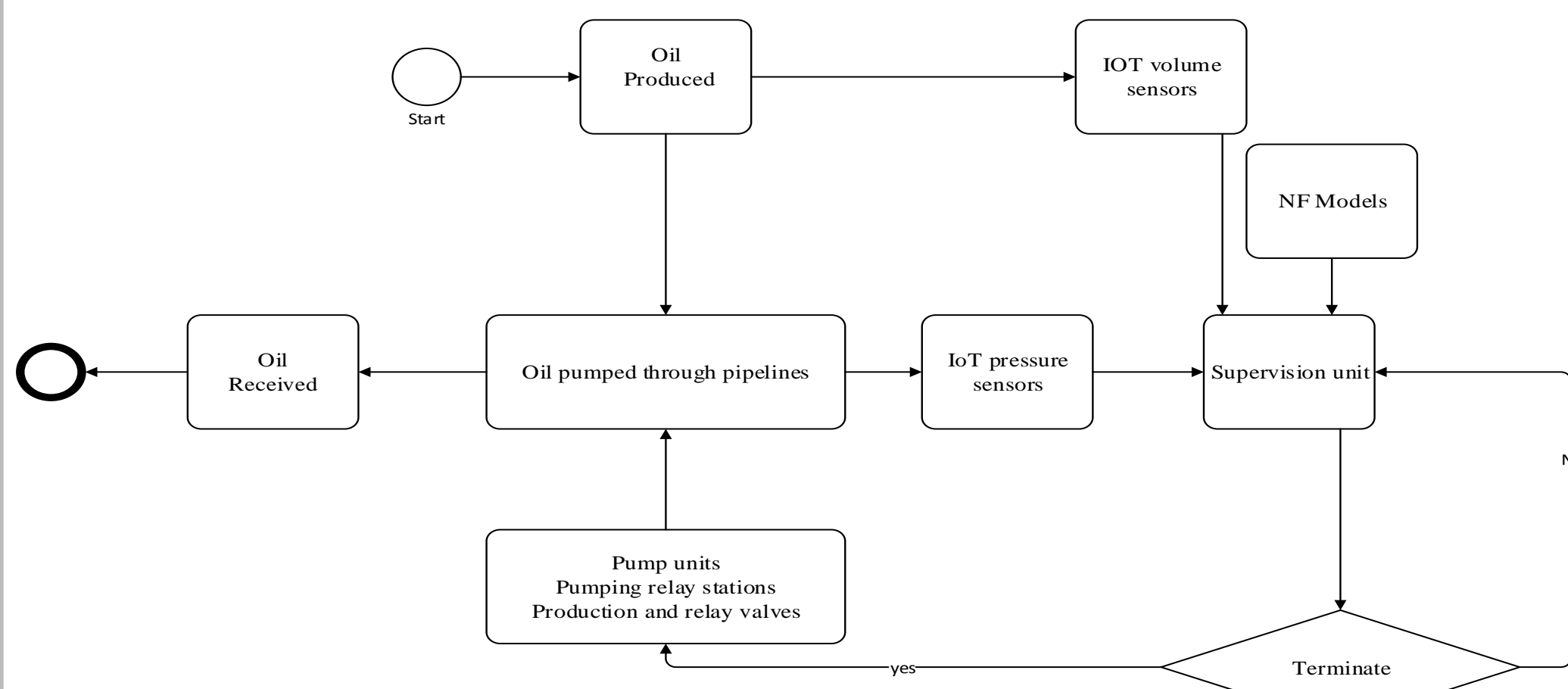

Fig. 1: Oil Pipeline Supervision System Flowchart

Conclusions

Promising results were obtained from the centred wired supervision system for oil pipeline transportation grids. It showed a remote control on the process if a leakage existed with the support of IoT and AI. The results encouraged the start of the next phase.

Methodology

The first phase includes simulating the oil transportation process with Simscape/MATLAB (Fig. 2), collecting data for a normal conditions process, creating NF models, embedding the NF models in the supervision system. To test the NF supervision system's effectiveness, an oil pipeline leakage scenario is created, and the results were collected for the transportation process with and without the NF supervision system. This leads onto the beginning of the second phase of research; creating sub-networks.

The IoT sensors and actuators create self-diagnosing decentralized sub-networks in oil pipelines transportation grids. The AI systems should be embedded in sub-networks to analyse the information received. The sub-networks are all connected to the main supervision system.

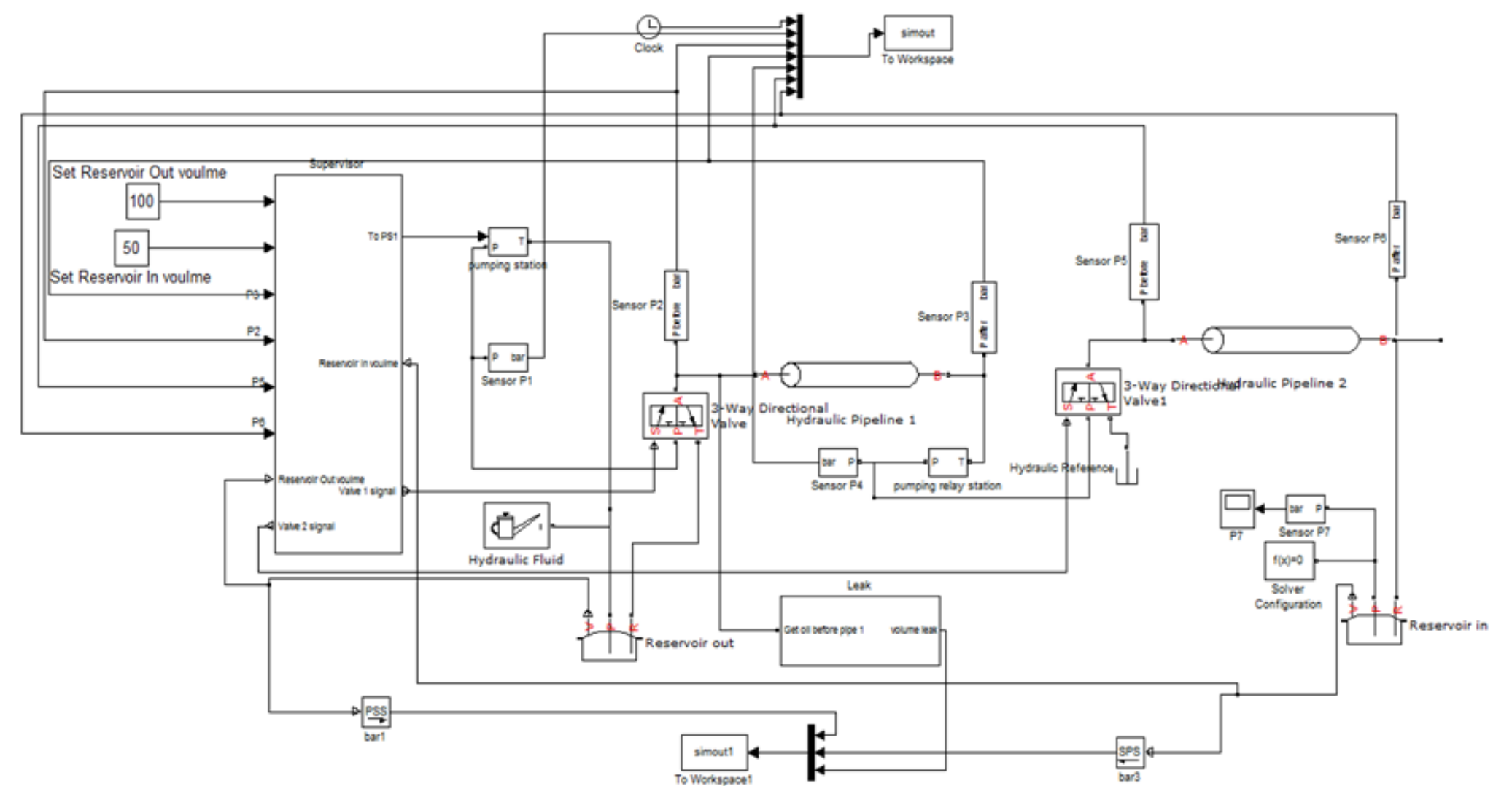

Fig. 2: Oil Pipeline Supervision System in Simscape

P2 NF model (in Fig. 3) for Pressure against volume in and volume out through the time. Model created for varies simulation data will be the prediction tool for the supervision system.

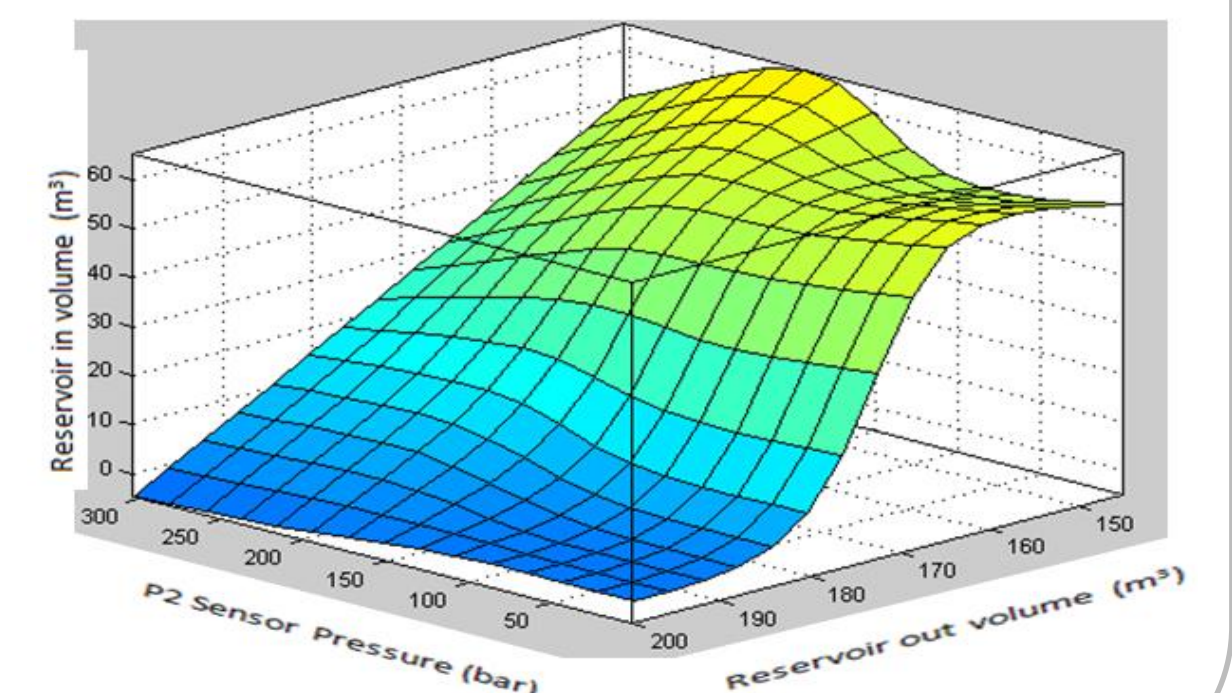

Fig. 3: 3D NF Model Surface for the pressure in P2 location

Phase One Results

Fig. 4 illustrates the consequence of the NF model in the transportation process. As shown by terminating the process the loss will be reduced.

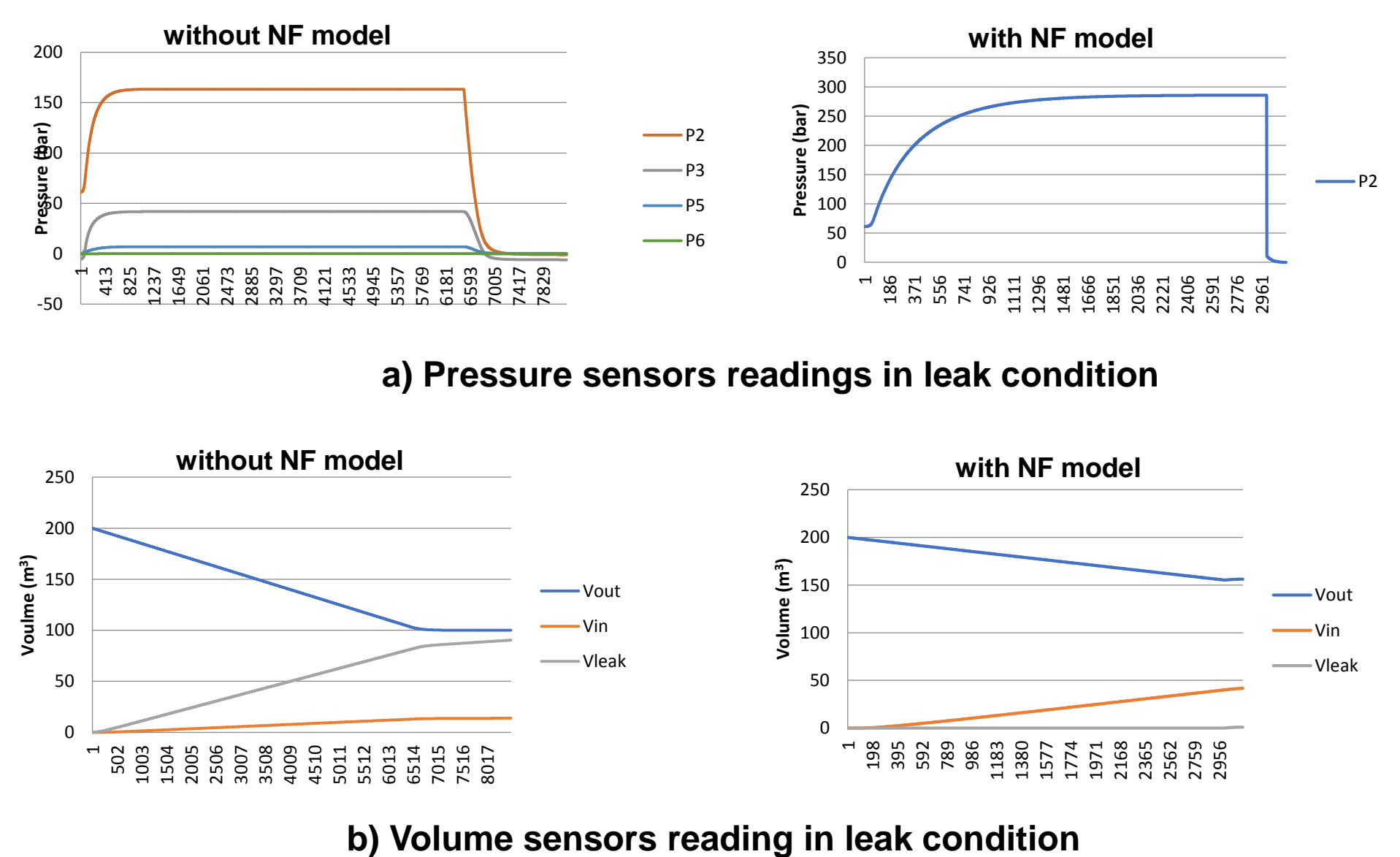

Fig. 4 : Pressure and volume sensor readings with and without NF model in leak condition

References

- [1] Al-Fuqaha, M. Guizani, M. Mohammadi, M. Aledhari, and M. Ayyash, "Internet of Things: A survey on enabling technologies, protocols, and applications," *IEEE Commun. Surv. Tuts.*, vol. 17, no. 4, pp. 2347–2376, 4th Quart., 2015.
- [2] Jang, J.-S.R. and Sun, C.-T., "Neuro-Fuzzy Modeling and Control", *Proc. IEEE*, v. 83, n. 3, pp. 378-406, March, 1995.
- [3] The second Iraqi conference IEHS-Uk 2017, RSK presentation, RSK.