

Opportunities for Optical Access Network Transceivers Beyond OOK [Invited]

Domaņić Lavery, *Member, IEEE*, Thomas Gerard, Sezer Erkılınc, *Member, IEEE*, Zhixin Liu, *Member, IEEE*, Polina Bayvel, *Fellow, IEEE*, and Robert I. Killey, *Member, IEEE*

Abstract—In response to the ever-growing challenge of using conventional direct modulation/direct detection transceivers for upgrading passive optical networks, there has recently been a surge in interest in alternative transceiver technologies. Candidate systems include (simplified) coherent receivers, and digital signal processing in combination with direct detection. Beyond these mainstream solutions, other, more esoteric, system designs have been proposed, including networks based on general purpose signal processing hardware, split carrier transmitters, and ultra-wide bandwidth coherent receivers. Herein, we review these techniques, and detail an experimental investigation of an ultra-wide bandwidth coherent receiver. It is found that the use of a dual-local oscillator receiver in an ultra-dense wavelength division multiplexed passive optical network (UDWDM-PON) enables the simultaneous detection of multiple upstream channels whilst efficiently using the complete receiver optoelectronic bandwidth.

Index Terms—Access Networks, Passive Optical Networks (PON), Digital Signal Processing, Coherent Receivers.

I. INTRODUCTION

OPTICAL access networks have reached a tipping point. Their inception as a passive optical network (PON) based on directly-modulated lasers, on-off keying (OOK), and time division multiplexing (TDM) was a revolution in the late 20th century. However, in the intervening two decades surprisingly little has changed.

This could, in part, be attributed to the cost-sensitivity of the access network; the cost-per-bit cannot exceed what an end user is prepared to pay. Nonetheless, within this challenging cost envelope, the aggregate line rate of the network has increased by two orders of magnitude; from the 622 Mbit/s APON (ITU Recommendation G.983.x) 1998, to the 40 Gbit/s NG-PON2 (ITU Recommendation G.989.x) 2013, and soon 50 Gbit/s with the advent of the 50G EPON (IEEE 802.3ca). This has mainly been enabled by advances in the optoelectronic bandwidth of transceiver components although more recently, as with NG-PON2, this has been facilitated by a move to TDM signalling across several coarse wavelength division multiplexed (WDM) channels (also known as TWDM).

The use of WDM in optical access networks was an unavoidable break with convention, due to the limitations within single channel transmission. For any link using intensity modulation with direct detection (IM-DD), an increase in symbol rate will lead to an increased dispersion penalty. At the same time, the increased symbol rate inherently requires

a greater optical power to maintain link budget, and also a greater optoelectronic bandwidth to avoid further penalties. Alternatively, higher order modulation formats [1] can be used to reduce the bandwidth requirements and dispersion penalty, but the reduced Euclidean distance between discrete signalling levels degrades the receiver sensitivity. Further, generating such formats using direct modulation can result in a significantly reduced signal power at the transmitter. By contrast, WDM allows lower line rate channels to be transmitted simultaneously, and detected independently, provided that a tunable optical filter is available in the receiver to reject the other WDM channels.

Despite a wide range of proposals to change the access network (reflective PON [2], [3], SuperPON [4], [5], Long reach PON [6], [7]), in reality there has been little appetite to move away from standards based on a power-splitting ODN with a relatively modest reach and split ratio. The reasons for this include the simplicity of network deployment and management, the ease of upgrades, and backwards compatibility. Going forward, it seems clear that further scaling the number of WDM channels in combination with upgraded transceiver designs, will be required to increase the aggregate network line rate.

Therefore, in this paper, we briefly compare transceiver technologies which could be used for future optical access networks. Section II reviews the relative merits of a range of modulation formats, receiver technologies (direct detection, coherent, and quasi-coherent), and transmission techniques, all of which are tailored to the specific challenges of multi-user optical access networks. Section III outlines the challenge of transmission using a large number of WDM channels, and provides a detailed description of a new technique for channel aggregation in a wide bandwidth coherent receiver within an optical line terminal (OLT). The details of an experimental validation of this technique are given in Sections IV and V and, finally, the conclusions are in Section VI.

II. OPTIONS FOR LOW COMPLEXITY TRANSCEIVERS: BEYOND ON-OFF KEYING

There have been many competing and complementary innovations in the area of low complexity transceivers, all seeking a solution for transmission beyond IM-DD with binary modulation. This section is intended to provide a summary of the salient transceiver designs and recent results for optical access networks, with a focus on the more unusual designs of recent years. However, this is a very diverse area of study.

The authors are with the Department of Electronic and Electrical Engineering, University College London, London, WC1E 7JE, United Kingdom e-mail: d.lavery@ucl.ac.uk

Considering this, the following references cover the key topics discussed in this section in a level of detail that would not be desirable in a single paper.

For a summary of the technical rationale behind the recent ITU standards, the reader is referred to [8], [9]. For a detailed discussion of coherent techniques for PON, we refer to the summaries in [10], [11], [12], [13]. Finally, for a discussion of the advanced direct detection techniques, see the review and experimental investigations in [14].

A. Analog Solutions

Many solutions for future access networks have recently been proposed, however some of the most promising options for transceiver design actually date back to the previous century; this is because such transceivers can be implemented without digital signal processing. The stalwart of access networks, on-off keying, suffers from an increased dispersion penalty as data rates increase, which limits transmission reach. Further, the near equivalence between the optoelectronic bandwidth requirements and the data rate mean that the generation of OOK signals (via direct or external modulation), becomes very challenging beyond 50 Gb/s, and the transmission reach at 100 Gb/s is correspondingly short; for example, the demonstration in [15] had a transmission reach of just 2 km.

Perhaps the simplest modification to direct detection with OOK is 4-ary pulse amplitude modulation (PAM4), which encodes two bits of data into four amplitude levels per symbol period. The reduced bandwidth requirements versus OOK provide enhanced dispersion tolerance and reduced optoelectronic bandwidth requirements. In order to maintain a high extinction ratio, PAM4 is typically generated with an electroabsorption modulator (EAM) as part of an externally modulated laser (EML). To date there have been many demonstrations of PAM4, and efforts have focussed on maintaining transmission performance, despite the inherent sensitivity penalty of higher order modulation formats. Aside from the technical challenge, there is a practical issue of how best to receive the PAM4 signals. A low complexity, analog detector was recently demonstrated in [16] which achieves this by using high speed combinatorial logic to extract the two data bits from each PAM4 symbol, enabling the reuse of low cost components designed for OOK.

Some of the limitations of PAM4 have been overcome using electrical duobinary (EDB), which also encodes two bits per symbol period. The advantage of EDB is the inherently reduced spectral width of the signal, which can be exploited to minimise dispersion penalty. This was recently compared with PAM4 at 50 Gb/s, where it was shown that EDB not only outperformed PAM4 in terms of back-to-back sensitivity, but also retained its sensitivity after 20 km transmission over standard single mode fibre [1]. As an alternative to EDB, unequally-spaced PAM4 have been employed in [17], specifically for access networks. This is a type of one-dimensional geometric shaping, which compensates for the nonlinearity of the direct detection process in order to reduce the probability of making an error versus uniform PAM4 (in the referenced work, the sensitivity improved by more than 1 dB).

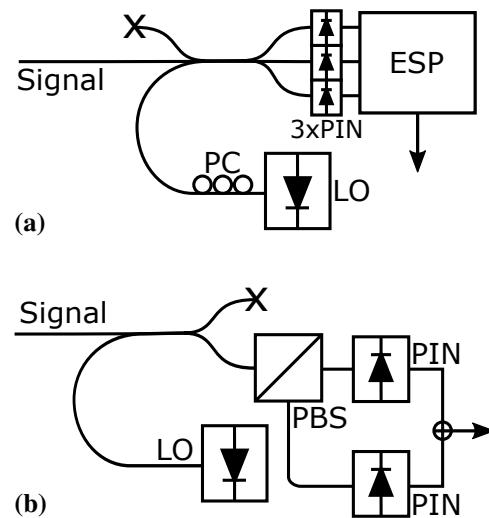

Fig. 1. Quasi-coherent receivers. (a) The balanced receiver used for burst mode OOK detection in [1] (this uses analog electrical signal processing (ESP), but is not polarization-independent), and (b) the single-ended receiver demonstrated in [20], [21] (this is also analog, but exploits a polarization beam splitter for polarization insensitivity). Key – PBS: Polarization Beam Splitter, PIN: PIN Photodiode, LO: Local Oscillator Laser, PC: Polarization Controller.

Although geometric shaping could also be applied to a higher order modulation format, such as PAM8, the use of only a single dimension for modulation (i.e., amplitude) impairs the sensitivity, and only increases the data rate per symbol by 50% versus EDB or PAM4. Nevertheless, PAM8 has been investigated in, e.g., [18], where this format was used as part of an adaptive modulation scheme to increase the per-channel rate up to 30 Gb/s using 10G-class optics .

Although most amplification schemes, such as erbium amplifiers or distributed Raman amplification, are prohibitively complex for a PON (particularly as an ONU preamplification method), it is possible to combine a low-complexity semiconductor optical amplifier (SOA) with a PIN photodetector to improve sensitivity [19], [17]. This is in contrast to using a high sensitivity photodiode, such as an avalanche photodetector (APD). The relative cost and merit of APDs versus SOAs is still a subject of investigation, although it should be noted that SOAs are, for the purposes of a PON, bandwidth-insensitive, and format-agnostic.

A promising alternative to direct detection is *quasi-coherent detection*, also known as coherent amplification. These names are given to receivers that use a local oscillator laser (LO) to provide a local reference signal for detection (thereby enhancing sensitivity), but are otherwise operating as a standard, analog, direct detection receiver. There are several analog coherent receivers that fall into this class, and these have been reviewed in [10]. One proposed approach to move incrementally towards coherent detection in access networks is to use a 3-photodiode (i.e., balanced and phase diverse) coherent receiver (see Fig. 1(a)) to detect a TDM upstream signal, in such a way that the chirp of upstream signal is not detrimental to the process of coherent detection. An exceptionally high power budget of 40 dB was demonstrated at 25 Gb/s in [1], taking a negligible penalty for burst mode operation.

However, a shortcoming of this class of receivers is that they are polarization sensitive; the LO and the signal must have the same state of polarization. All receivers which fall into this class must be modified in some way to allow them to receive a signal, irrespective of the signal state of polarization. The first example of a coherent receiver explicitly and generally addressing this problem was developed by Glance *et al.* in 1987 [20]. The proposed technique involved detecting both states of polarization simultaneously, and simply summing the magnitude of the detected polarization components. Although there is a minimum penalty of 3 dB for this approach (6 dB if the phase components are not independently detected), the receiver does not require polarization alignment to detect a signal. This technique, shown in Fig. 1(b), has since been adapted for the modern PON standards [21], but the operating principle is very similar.

The relative merits of these approaches are detailed in [10], so we will not reiterate here. However, an important point to note about quasi-coherent, analog receivers is that they are not, in general, scalable to high order modulation formats. Several designs (e.g., [22], which implicitly relies on polarization scrambling) are constrained to OOK, and others rely on envelope detection, which destroys phase information. Therefore, as with IM-DD systems, quasi-coherent solutions cannot easily be used to scale bandwidth efficiency beyond PAM4. Notwithstanding this limitation, 25 Gb/s PAM4 was recently demonstrated using a polarization independent design (a hybrid between the two designs shown in Fig. 1), although achieving a power budget of only 17 dB after 21 km transmission [23].

B. Digital Solutions

Echoing the rapid advance of DSP-aided coherent receivers in long-haul networks, there is now an interest in DSP-aided receivers for access networks. Naturally, the benefits of DSP in long-haul networks are different to access. In long-haul, the accumulated chromatic dispersion is orders of magnitude greater than in access networks, and other effects such as polarization mode dispersion, stochastic polarization rotations and, to a certain extent, Kerr nonlinearity, all become significant, and can all be mitigated by DSP.

In an access networks, DSP has been proposed, primarily, to extend the operating capability of the current generation of low cost optics, and there are two competing models for this. One is to enhance direct detection transceivers by using DSP (also known as DD+DSP). The other is to use DSP to enable phase detection in a coherent receiver (sometimes called simplified digital coherent receivers), and then exploit this phase recovery for advanced modulation and channel mitigation. Unless otherwise noted, all the receivers discussed in this subsection employ an analog-to-digital converter (ADC) to enable the DSP solution.

Starting with the direct detection options, perhaps the simplest use of DSP is to enable a bandwidth extension of the current optoelectronic hardware generation. Although not strictly for access networks, a recent demonstration of high symbol rate OOK used DSP to enable transmission

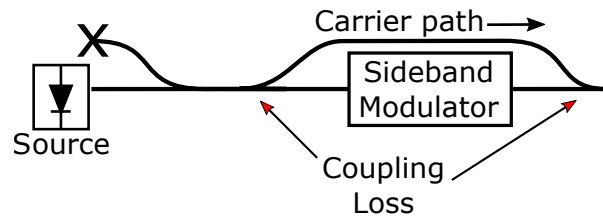

Fig. 2. A split carrier transmission scheme. This method of generating single- or double-side band signals has been successfully tested in inter- and intra-data center networks. Provided the carrier path has a lower insertion loss than the modulator path, then this scheme will be more power efficient than passing the carrier through the modulator, and will inherently produce a carrier-to-signal power ratio greater than unity.

of 140 GBd and 204 GBd OOK signals over 80 km and 10 km, respectively [24]. The hardware used is of an infeasible complexity for the next generation of PONs, but it is perhaps of interest to note that OOK could still be a possibility, even for per-channel rates beyond 100 Gbit/s. The DSP used to achieve this involved a 5-tap feed forward equalizer (FFE) and 3-tap maximum *a posteriori* (MAP) processing.

For advanced modulation formats, other equalization techniques have been applied to further improve performance. For example, in [25], PAM4 was enabled by a combination of maximum likelihood sequence estimation (MLSE) and a channel shortening filter (which trades off improved channel response with additional inter-symbol interference, which is then compensated by the MLSE).

However, for simplicity in access network specific demonstrations, it is now common for the FFE to be used in isolation to improve bandwidth and dispersion tolerance, or combined with a relatively simple decision feedback equaliser (DFE). There are many examples where these DSP techniques are applied, however we highlight [26], which used a combination of FFE and DFE, as well as an SOA-PIN and an EML, to enable transmission of PAM4 at 50 Gb/s/λ over 20 km, whilst achieving a 32.5 dB power budget. This is a particularly impressive demonstration, as it shows the feasibility of using DSP to enable a 50 Gb/s transmission system, with very little additional optical complexity versus a 25 Gb/s system.

When considering new transceiver designs for PON, it is instructive to look to the research in intra- and inter-data center networks, as they have similar volumes to access networks, and similar complexity and data rate requirements. The recent work by [27] on ‘coherent-lite’ transmission systems (which, again, is an analog coherent system) provides insight into how DSP complexity can be avoided in short reach networks, at the expense of optical complexity. Here, a homodyne system is enabled by using a fibre pair to send a signal plus a carrier, which is then used as a LO source. Conversely, however, one may wish to minimise the optical complexity, at the expense of DSP. The latter scenario is much more applicable to the current research direction in access networks, and was recently addressed in [28]. Here, 4×112 Gb/s PAM4 signals were transmitted over 300 km using a dispersion-pre-compensating transmitter but a single photodiode receiver. A power preserving modulation scheme (see Fig. 2) meant that a high power carrier could be inserted into the signal, whilst avoiding the loss of

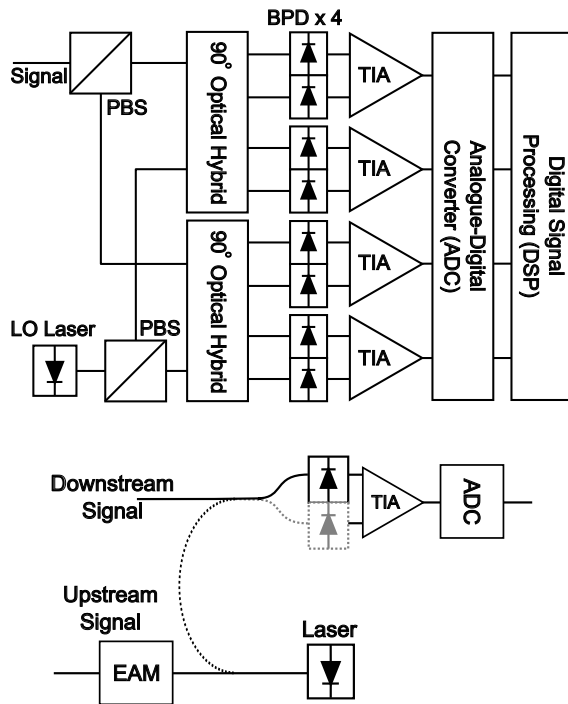

Fig. 3. [top] A conventional polarization- and phase-diverse coherent receiver. [bottom] a direct detection ONU, which can be converted to a simplified, balanced, heterodyne, coherent ONU with the addition of the dashed paths (the addition of a BPD, as shown in grey, is optional). Despite being little more complex than a direct detection ONU, it is compatible with some coherent transmission schemes, such as Alamouti coding. Key – BPD: Balanced Photodetector, TIA: Transimpedance Amplifier.

the external modulator. This approach has since been used in an intra-datacenter scenario, where a lower complexity, double side-band modulation scheme could be used, due to the low accumulated dispersion [29]. This technique inherently enables a power-efficient generation of advanced modulation formats at high data rates, but requires transmitter- and receiver-side DSP. Nevertheless, this transceiver design has potential for use in optical access networks, as it preserves carrier power after external modulation and so increases power budget for a fixed laser output power.

For completeness, we note a relatively new technique which has been applied to direct detection receivers, called Kramers-Kronig (KK) detection [30]. Square law detection is inherent to standard photodetectors. That is, photodetectors measure the magnitude of the incident electromagnetic field, rather than the field itself. Phase information is, therefore, destroyed in this process. It is possible to partially linearise the receiver using KK DSP, and this was shown for an access network scenario in [31]. It should be emphasised that, whilst this does not convert a direct detection receiver into a coherent receiver, it does, to some extent, enable advanced modulation formats and digital chromatic dispersion compensation. However, as this is an inherently nonlinear process, there is a requirement for oversampling of the signal before the DSP is applied [32].

So far we have discussed direct detection, DD+DSP, and quasi-coherent receivers, however it is DSP combined with coherent detection that is currently the gold standard of long-haul communications. In PON scenarios, research has shown

that digital coherent receivers can enable an entire restructuring of the network, especially concerning the wavelength plan and the use of time division multiplexing. A typical four-dimensional coherent receiver¹ is shown at the top of Fig. 3; this receiver includes two 90 degree optical hybrids for phase recovery, and four balanced photodiodes (one per dimension).

Despite the comparison with long-haul communications, digital coherent receivers need not be high complexity. For example, a prototype demonstration of a cost-effective transistor outline (TO)-can package including an EML-based coherent transceiver (with a single fiber access and single RF data input) which achieved transmission of up to 7.5 Gb/s with a 20 dB power budget [33]. Although these are rather modest results, it should be noted that this was the first demonstration of a dual use EML (as both transmitter and receiver), and arguably has a lower complexity than many of the DD+DSP solutions described, above. For reasons described later in this section, a high data rate may not be as important for coherent systems.

A further example of a low complexity coherent transceiver design is the polarization-diverse transmitter single-photodiode receiver; the receiver structure is shown in Fig. 3 (bottom). Here, the assumption is that, within any ONU, there must be at least a single photodetector² and a laser (here assumed to be an EML). The laser can be simultaneously used as an LO and as a source for upstream transmission³. Provided that the signal has been precoded such that the information is redundantly coded across both polarizations, then this receiver structure can be used to receive the signal.

The simplest method for this is polarization *scrambling* (e.g., using an external polarization modulator). Provided that the signal is present in both polarisation states for half of the symbol period, the signal can be recovered, albeit at an expense of a doubling in bandwidth requirement (as the symbol state changes at twice the symbol rate). An alternative approach is polarization-time block coding (also known as Alamouti coding), which *modulates* the data with 100% overhead across pairs of symbol periods and two polarizations. In this way, a receiver is able to recover all of the transmitted data, but without increasing bandwidth requirements. Additionally, Alamouti coding exhibits a fundamental 3 dB sensitivity advantage over polarization scrambling. It should be noted, however, that Alamouti coding requires DSP, whereas polarization scrambling can also be implemented without DSP and may, therefore, be simpler to implement than Alamouti coding [10]. Scrambling was demonstrated in [34]. As the scrambling must be performed at twice the symbol rate (and thus bandwidth limited), the data rates per wavelength in this work are relatively low (1.25 Gb/s). Notwithstanding this issue, this system is compatible with a dense WDM system (only one polarization scrambler is required, in principle), and the performance in a multi-channel scenario has been verified,

¹Phase and amplitude in two polarizations.

²Single photodetector coherent receivers are impaired by relative intensity noise from the LO laser, but this can be easily mitigated by instead using a balanced photodetector [13]. This is shown in grey in Fig. 3 (bottom).

³Although this would not be compliant with any of the ITU standards, to date, as this requires bidirectional transmission in the same wavelength band. However, the wavelength plan of any future standard could be adapted to accommodate this approach.

with receiver sensitivities as low as -45 dBm per channel. Alamouti coding has been shown to outperform scrambling, but at a greater complexity (polarization-diverse modulation is required for each channel). Nevertheless, in [35], bidirectional transmission was demonstrated over 100 km of installed fibre, verifying the principle of polarization independence in a practical scenario, whilst operating using 16-ary quadrature amplitude modulation (16QAM) to obtain a high bandwidth efficiency.

Given that the optical front end of the receiver shown in Fig. 3 is almost identical to a conventional direct detection receiver, it is natural to ask about the complexity of the ADC. The challenge with ADCs is that they have, in general, a high power consumption. However this can be mitigated if the number of quantization levels is reduced. The work in [36] describes a hypothetical receiver that employs a 2-bit ADC, thereby making the receiver complexity equivalent to that of the simplified PAM4 receiver described above [16], which used combinatorial logic to implement a 2-bit receiver. The 2-bit receiver was recently experimentally demonstrated in [37], where a combination of receiver-side clipping and DSP enabled the detection of 25 Gb/s Alamouti-coded 4QAM signals. The receiver sensitivity outperformed a near identical PAM4 ONU by 18.6 dB, albeit at the expense of DSP, and a more complex transmitter in the OLT. There is no fundamental reason why this approach would not work for the polarization scrambled transmitter configuration, which may also allow for a reduced OLT complexity; the exact performance of this configuration has not been experimentally verified.

For a power consumption estimate, we refer to the work of López *et al.* [38], where a 2-bit flash ADC and transimpedance amplifier was implemented for a high speed PAM4 receiver. The power consumption of this device was verified up to 24 GBd, and drew just 650 mW. This device's low power consumption could be a key enabler for either low complexity coherent receivers, or 50 Gb/s PAM4 receivers.

One seldom-discussed issue in this research area is the development and, therefore, the amortisation of the initial investment in, for example, application specific integrated circuits (ASIC) for the DSP. There will come a point when the demand for such ASICs is sufficient, and they are effectively commodified. However, in the meantime, there may be a high initial cost for any commercial deployment. An approach to deal with this issue was recently proposed, and is known as the Flexible Access System Architecture (FASA). The FASA proposes the use of general purpose hardware to enable real-time operation of DSP and forward error correction (FEC), without the development of ASICs. In [39], it was shown that, by using a central processing unit (CPU) and graphics processing unit (GPU), the DSP and FEC for a 5 Gb/s coherent QPSK signal could be executed in realtime, even when the signal was transmitted over 20 km. The FASA, therefore, demonstrates the possibility of cost-effectively accelerating both research and deployment in the area of DSP-aided access networks, and underlines the inherent feasibility of all the aforementioned techniques.

III. NETWORK IMPLICATIONS OF WAVELENGTH DIVISION MULTIPLEXING: A COHERENT SOLUTION

So far in this manuscript, we have discussed the motivation for receiver simplification in optical access networks. However, in this section, we describe a commonly investigated WDM transmission scenario, and show how a high complexity, wide bandwidth receiver can be exploited in this scenario to achieve an overall reduction in receiver complexity⁴.

A. Ultra Dense Wavelength Division Multiplexing

In contrast to earlier standards, one of the key additions of NG-PON2 was the use of TWDM. One could view this as inevitable; at the point when tunable ONU filters and lasers becomes cost-effective, it is easier to expand the transmission bandwidth in the optical domain, rather than in the optoelectronic domain. And yet, there is an inherent logic to using WDM in a multi-user access network scenario: why separate users in the time domain, when there is ample bandwidth available in the frequency domain?

This is the rationale behind the ultra-dense WDM (UDWDM) PON proposal, which abandons TDM altogether, and separates users only in the spectral domain. This requires tens, or even hundreds, of wavelengths per PON, hence the term *ultra dense*.

The UDWDM PON is only really practical with coherent receivers (although DSP is not a requirement) because coherent receivers have an inherent frequency selectivity – only the frequencies close to the LO frequency are detected. This means that, by changing the wavelength of the LO within an ONU, the channel of interest can be selected⁵.

Consider the network schematic shown in Fig. 4, which shows the wavelength plan of a UDWDM PON. For these networks, the frequency spacing is necessarily comparable to the symbol rate. A small spectral gap is required to facilitate bidirectional transmission, preventing in-band reflections from degrading performance⁶. Given the low symbol rate, and the narrow channel spacing, it is possible to receive multiple channels at the OLT using a single receiver.

In [43], for example, a coherent receiver-based OLT was able to detect 5×10 Gb/s upstream channels simultaneously. Despite using a full four dimensional coherent receiver, there is a potential cost advantage to be gained by using a single device to receive several channels. Clearly, aggregating a greater number of channels would increase the cost advantage, and this is the subject of the remainder of this section.

B. Operating Principle of a Dual-LO Coherent Receiver

A coherent receiver detects only channels that are (i) coherently mixed with the LO laser, and (ii) signals which then fall within the bandwidth of the optical and electronic receiver

⁴This technique and the accompanying results were first presented, in part, in [40].

⁵In contrast to an NG-PON2 system, a tunable filter is therefore not required in the receiver.

⁶The issue of reflections for UDWDM coherent PON was observed in [41], and mitigation strategies based on this wavelength plan were described in [42], [43].

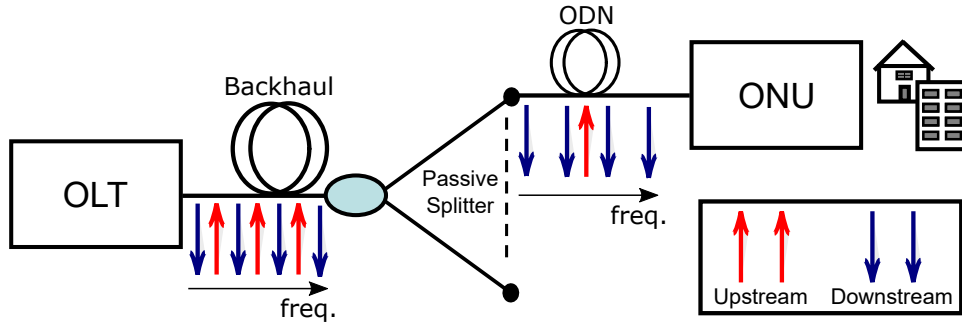

Fig. 4. Schematic of bidirectional (full duplex) transmission in a UDWDM PON, including the fiber backhaul and the optical distribution network (ODN). The wavelength plan is indicated. Note that each ONU communicates on an upstream frequency which is locked to, but frequency offset from, the downstream channels [46].

front end. As noted previously, this means that, bandwidth permitting, multiple channels can be received.

Now, if two LOs are combined into a receiver at different wavelengths, then different frequency ranges are simultaneously detected. Provided that these frequency ranges contain channels with sufficient gaps in the spectral domain, then a wider range of channels can be simultaneously received. In the case of a UDWDM PON, the linear crosstalk between channels in each frequency range can be avoided due to the spectral gaps inherent to the PON configuration (Fig. 4), as shown in Fig. 5.

Moreover, if upstream signals are frequency locked to the downstream signal (which is necessary when reusing the ONU LO for upstream transmission, as in Fig. 3) then a regular frequency grid is maintained. The received signal configuration at the OLT for this scenario is shown in Fig. 5 (left). The dual LO configuration produces the bandwidth-efficient digital spectrum shown in Fig. 5 (right).

To eliminate linear crosstalk when using this technique, channels on a $2f$ [Hz] frequency grid must be detected with a LOs spaced at $(n + 0.5)f$, where $n \in \mathbb{N}_0$.

Assuming the use of balanced photodetection, as in Fig. 3[top], the linear detection characteristic of the receiver is preserved when using the dual-LO technique. This is intuitive, as the detection characteristic of an ideal coherent receiver is linear, thus the separate LOs do not nonlinearly interfere. However, if the receiver is optically preamplified (as is the case, herein) then the use of additional LO lasers increases LO-noise beating terms [13], [44], which gives the following signal-to-noise ratio (SNR):

$$\text{SNR}_{\text{symbol}} = P_S / n_{\text{sp}} h\nu B N_{\text{LO}}, \quad (1)$$

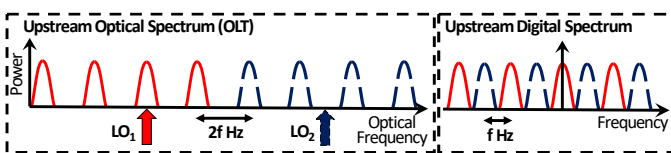

Fig. 5. Principle of a dual LO receiver: the two local oscillator lasers are frequency-centered as shown in the optical spectrum schematic [left]. After coherent detection, the high frequency channels (blue dashed) are mixed into the spectral gaps [right]. Channels with a $2f$ [Hz] frequency spacing in the optical domain, have a f [Hz] spacing in the digital domain.

where P_S is the channel power, $h\nu$ is the photon energy, n_{sp} is the erbium doped fiber (pre-)amplifier (EDFA) spontaneous emission factor, B is the channel bandwidth, and N_{LO} is the number of LOs used. For a dual-LO system, this performance degradation is 3 dB, which is potentially acceptable when considering the significantly decreased number of receivers required at the coherent OLT⁷. Note that the use of optical preamplification is not essential, and was used in the following investigation as the high speed BPDs used in this work did not incorporate TIAs.

IV. EXPERIMENTAL CONFIGURATION

To ease the comparison with earlier work, the system parameters were selected similarly to [43], where polarization multiplexing at the ONU was not considered. The experiment was conducted as shown in Fig. 6. For the experiment presented herein, 32 wavelength division multiplexed channels were generated to represent the upstream signal (i.e., from ONU to OLT). Four external cavity lasers (ECL)⁸ ($\lambda = 1549.6, 1550.0, 1550.4, 1550.8$ nm) were modulated using ‘IQ’ modulators (15 GHz electrical bandwidth), driven by 90 GSa/s digital-to-analog converters (DAC). The signals were precoded such that each seed generated 8 channels via subcarrier multiplexing. In total, 32×3 Gbd root raised cosine pulse shaped (roll-off factor, 0.1) single polarization 16QAM signals were generated. The subcarrier spacing was set to 6.5 GHz, which is slightly beyond the Nyquist limit.

The signal power was set to 2.5 dBm per subcarrier and attenuated using a variable optical attenuator (VOA) to emulate the loss of a 1:32-way power splitter/combiner. This signal was then transmitted over 80 km standard single mode optical fibre with a total span attenuation of 15.6 dB, before being passed to the OLT.

The OLT comprised an EDFA preamplifier (5.5 dB noise figure), followed by a phase- and polarization-diverse coherent receiver, as in Fig. 3, but where two LO lasers were coupled

⁷If a periodic filter, such as an optical interleaver, is included between the EDFA and the receiver, then the noise in the spectral gaps can be filtered and this penalty can, theoretically, be eliminated.

⁸These external cavity lasers have a performance (linewidth 100 kHz, relative intensity noise -150 dBc/Hz) in line with modern, C-band tunable, commercial, volume-production semiconductor lasers; for example the digital supermode distributed Bragg reflector (DS-DBR) laser [45]. Therefore, their use is meant to be indicative of the performance using this type of laser.

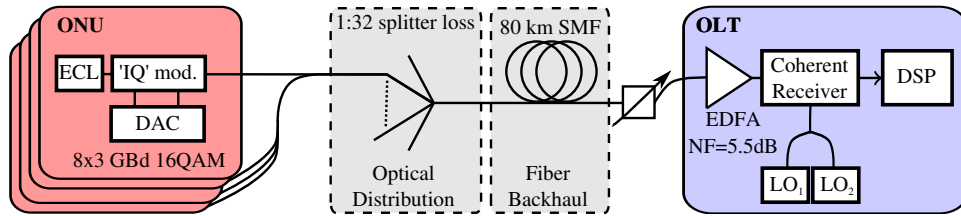

Fig. 6. Experimental configuration. The four transmitters combined emulate the upstream signal from 32 ONUs (8×4 subcarrier multiplexed channels). The two LO lasers extend the usable bandwidth of the receiver.

into the receiver instead of the usual one. The photodetectors used in this work did not include TIAs, so the EDFA was required to provide sufficient signal power to the photodetectors – preamplification is not a general requirement of this technique. Following the photodetectors, the signal was digitised using ADCs at 160 GSa/s, which thus provided a combined effective optical bandwidth of 120 GHz. The two LOs used in this experiment were frequency-separated by 103 GHz, and centered close to 1549.8 and 1550.6 nm, with a power per LO onto each balanced photodiode of -8 dBm.

The first step of the DSP chain was to frequency shift each of the 32 channels in the detected signal to baseband, and resample to 2 samples-per-symbol. Subsequently, for each of the 32 channels, a conventional DSP chain was used for signal recovery. From the perspective of a real hardware implementation of this technique, aside from the initial frequency shift and reampling step, the remainder of the DSP can operate at a much lower sample rate and, therefore, a lower ASIC clock frequency. The per-channel DSP used a 2×2 butterfly, 31-tap adaptive equaliser updated using the multi-modulus algorithm, which simultaneously compensated fiber chromatic dispersion, applied the matched pulse shape, and recovered the signal state of polarization. This was followed by a fourth power frequency offset estimator, a 16-tap decision-directed phase recovery and bit error rate (BER) estimation.

V. RESULTS AND DISCUSSION

In order to verify that the linearity of the receiver was preserved, as predicted theoretically, the system was investigated in both a back-to-back configuration (as a control case) and after 80 km transmission. In the latter case, a significant additional penalty would have been expected if the receiver were in any way nonlinear, as this would impair the performance of the chromatic dispersion compensation DSP.

In the back-to-back configuration, the principle is shown to work, and can be visualised in the spectra shown in Fig. 7(a). The bottom trace shows the optical spectrum (as measured by an optical spectrum analyzer) and the top trace shows the digitally measured signal. The spectrum of the digital signal no longer has large spectral gaps.

The performance of the best- and worst-performing channels is shown in Fig. 7(b). Due to the experimental technique used (subcarrier modulation), and the limited bandwidth of the IQ modulators, the outer channels from each group of 8 exhibited a performance penalty. Again, this is not inherent to the technique, and it is anticipated that this would not manifest in a real system, using separate modulators for each channel.

For this investigation, we considered BER thresholds for FEC of 3.8×10^{-3} and 1.5×10^{-2} , as in [43]. No significant performance difference was noted between the signal quality in the back-to-back and transmission configurations at these BER thresholds, meaning that the linear detection characteristic is, indeed, preserved. In Fig. 7(c), after 80 km transmission, the performance is maintained, despite the non-deterministic received state of polarization or the accumulated chromatic dispersion. With these sensitivities (at either FEC threshold), it is possible to transmit 80 km with a 1:32-way split. We observe a 4.9 dB (8.9 dB) excess power budget at the 7% (20%) FEC thresholds, respectively.

Ideally, in this work, we would have also investigated the performance of photodetectors integrated with TIAs. However, the commercial availability of TIAs at such high bandwidths is currently very limited. Nonetheless, it is still rational to use EDFAs in this context, as this is a shared component at the OLT, and therefore less sensitive to cost. As noted, above, the inherent 3 dB penalty stated in Eq. (1) can be mitigated if an optical interleaver is placed after the amplifier. This would be in place of the arrayed waveguide grating which would otherwise be required for separate receivers, and thus does not represent an increase in complexity.

The results in Fig. 7 show the feasibility of using a dual-LO receiver to simultaneously detect 32×10 Gb/s channels in a single receiver, thus sharing the cost of the EDFA and all receiver components between 32 users. By sharing such a large part of the total cost of the OLT, it changes the economics of the PON. Conventional wisdom suggests that transceivers should be designed that are the lowest possible complexity for the target bit rate (as described in Section II). But, could high complexity receivers, which offer a greater *functionality*, actually be more cost effective?

To highlight the effectiveness of this approach, we provide some examples. For a comparable configuration to the aforementioned 1.92 Tb/s PON[43], just 6 coherent receivers would be required at the OLT to receive all 192 channels using the high bandwidth receiver combined with the dual LO technique. Although the dual-LO technique was demonstrated for a UDWDM-PON configuration, it can be applied to other configurations, such as time and wavelength division multiplexed PONs. The coarser frequency grid (typically 50 GHz for NG-PON2 [9]), leaves substantial spectral gaps which can be exploited to detect several upstream channels simultaneously. The receiver used in this work has sufficient bandwidth to aggregate four NGPON2 wavelengths with two LOs. Finally, we note that the ability of the dual-LO configuration to

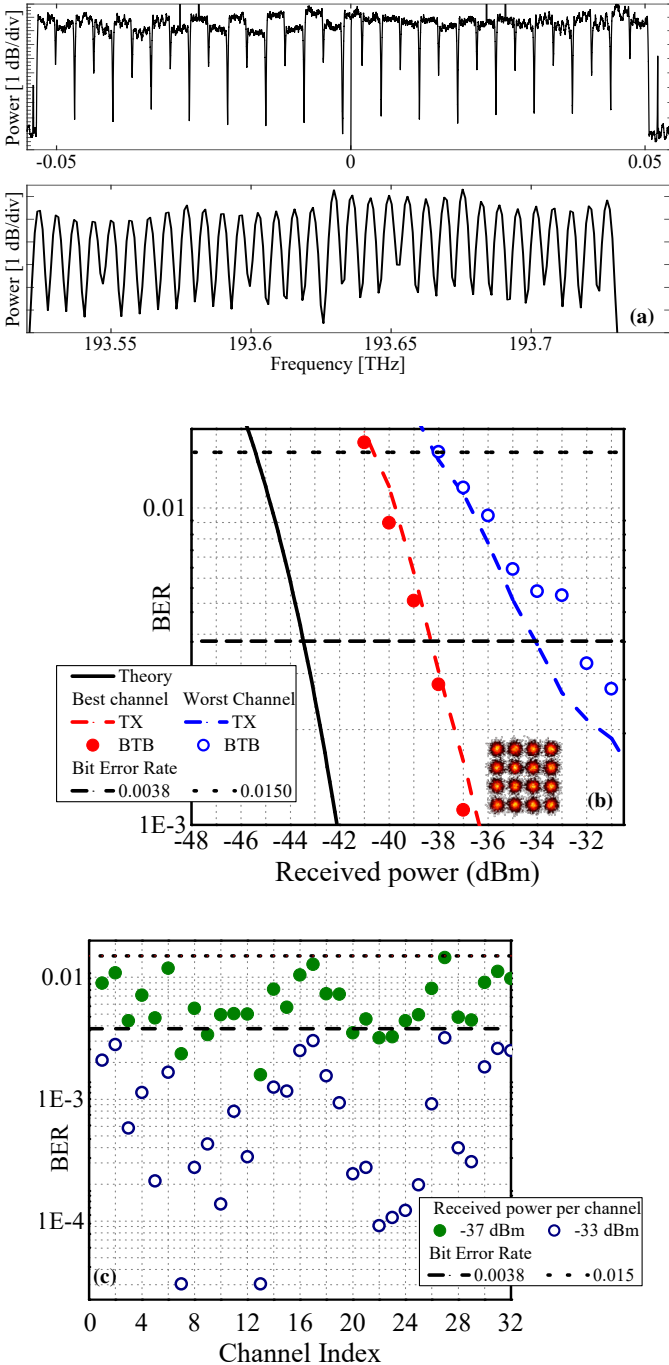

Fig. 7. (a) Digital (top) and optical 0.02 nm resolution (bottom) spectra for the upstream UDWDM-PON, (b) back-to-back and transmission performance for the best- and worst-performing channels (the constellation indicates the best-performing channel after transmission at -37 dBm). The theoretical curve is calculated using Eq. (1). (c) The sensitivity at the FEC thresholds after transmission.

mix disparate wavelengths down to baseband means that this configuration can also be used for dual homing, or legacy PON upgrades.

VI. CONCLUSION

The capability of the transceivers used for optical fibre communications has come a long way in the last two decades. However, due to the stringent cost constraints of access networks, PON standards are still almost exclusively based on TDM-OOK with direct detection. Herein, we reviewed the most likely techniques to supersede TDM-OOK. The contenders included the conventional approaches – DD+DSP, and simplified coherent – but also some more unusual techniques, including quasi-coherent and polarization-independent coherent receivers, split carrier transmitters, hybrid transmitter-receiver EMLs, and the Kramers-Kronig receiver linearization technique.

One of the proposed techniques was a wide-bandwidth coherent receiver, which used two local oscillator lasers in order to double the bandwidth efficiency at the OLT (upstream) of a UDWDM-PON. This was shown, experimentally, to allow the simultaneous detection of 32×10 Gb/s channels.

We single out this technique as particularly unusual, as it requires optical components which would be state-of-the-art, even for, say, a long-haul optical fiber communications system. However, by detecting so many channels simultaneously, the per-user cost of this technique is potentially acceptable. Further, by using coherent detection in this system, the receiver sensitivity and bandwidth efficiencies are significantly beyond what can be achieved with DD+DSP. Finally, by combining coherent detection with digital signal processing, chromatic dispersion can be readily compensated without penalty.

In theory, through simultaneous use of the coherent optical front end, just 6 receivers are required for a 192-channel UDWDM-PON. This enables a cost-effective coherent OLT, as significantly fewer components (i.e., optical hybrids, lasers, photodetectors, and polarization beam splitters) are required.

ACKNOWLEDGMENT

Supported by the Royal Academy of Engineering under the Research Fellowships scheme, and EPSRC programme grants EP/J017582/1 ‘UNLOC’ and EP/R035342/1 ‘TRANSNET’.

REFERENCES

- [1] D.v. Veen and V. Houtsma, “Bi-directional 25G/50G TDM-PON with extended power budget using 25G APD and coherent amplification,” in Proc. Optical Fiber Communication Conference, PDP Th5A.4, 2017.
- [2] K. Y. Cho, Y. Takushima and Y. C. Chung, “10-Gb/s Operation of RSOA for WDM PON,” in IEEE Photonics Technology Letters, vol. 20, no. 18, pp. 1533-1535, Sept.15, 2008.
- [3] M. Brunero *et al.*, “WDM PON RSOA-based self-tuning transmitters: An insight from the EU FP7 ERMES project,” 2015 17th International Conference on Transparent Optical Networks (ICTON), Budapest, 2015, pp. 1-4.
- [4] D. J. G. Mestdagh and C. M. Martin, “The super-PON concept and its technical challenges,” Proceedings of the International IFIP-IEEE Conference on Broadband Communications, Global Infrastructure for the Information Age, 1996, pp. 333-345.
- [5] L. B. Du *et al.*, “Long-reach wavelength-routed TWDM PON: technology and deployment,” in Journal of Lightwave Technology, PP

- [6] D. P. Shea and J. E. Mitchell, "Long-Reach Optical Access Technologies," in IEEE Network, vol. 21, no. 5, pp. 5-11, Sept.-Oct. 2007.
- [7] P. Ossieur *et al.*, "A 135-km 8192-Split Carrier Distributed DWDM-TDMA PON With 2, *times*, 32, *times*, 10 Gb/s Capacity," in Journal of Lightwave Technology, vol. 29, no. 4, pp. 463-474, Feb.15, 2011.
- [8] J. S. Wey *et al.*, "Physical layer aspects of NG-PON2 standards - Part 1: Optical link design [Invited]," in IEEE/OSA Journal of Optical Communications and Networking, vol. 8, no. 1, pp. 33-42, January 1 2016.
- [9] Y. Luo *et al.*, "Physical layer aspects of NG-PON2 standards Part 2: System design and technology feasibility [Invited]," in IEEE/OSA Journal of Optical Communications and Networking, vol. 8, no. 1, pp. 43-52, January 1 2016.
- [10] M. S. Erkilinç *et al.*, "Comparison of Low Complexity Coherent Receivers for UDWDM-PONs (*lambda*-to-the-User)," in Journal of Lightwave Technology, vol. 36, no. 16, pp. 3453-3464, Aug.15, 15 2018.
- [11] A. Shahpari *et al.*, "Coherent Access: A Review," in Journal of Lightwave Technology, vol. 35, no. 4, pp. 1050-1058, Feb.15, 15 2017.
- [12] N. Suzuki, H. Miura, K. Matsuda, R. Matsumoto and K. Motoshima, "100 Gb/s to 1 Tb/s Based Coherent Passive Optical Network Technology," in Journal of Lightwave Technology, vol. 36, no. 8, pp. 1485-1491, April15, 15 2018.
- [13] D. Lavery *et al.*, "Digital Coherent Receivers for Long-Reach Optical Access Networks," in Journal of Lightwave Technology, vol. 31, no. 4, pp. 609-620, Feb.15, 2013.
- [14] V. Houtsma and D. van Veen, "A Study of Options for High-Speed TDM-PON Beyond 10G," in Journal of Lightwave Technology, vol. 35, no. 4, pp. 1059-1066, Feb.15, 15 2017.
- [15] J. Verbist *et al.*, "First Real-Time 100-Gb/s NRZ-OOK Transmission over 2 km with a Silicon Photonic Electro-Absorption Modulator," in Optical Fiber Communication Conference Postdeadline Papers, OSA Technical Digest (online) (Optical Society of America, 2017), paper Th5C.4.
- [16] D. v. Veen *et al.*, "Demonstration of symmetrical 25 Gbps quaternary PAM/duobinary TDM-PON with multilevel interleaving of users," in Proc. European Conference on Optical Communication, 2015, pp. 1-3.
- [17] J. Zhang *et al.*, "Experimental Demonstration of Unequally Spaced PAM-4 Signal to Improve Receiver Sensitivity for 50-Gbps PON with Power-Dependent Noise Distribution," in Optical Fiber Communication Conference, OSA Technical Digest (online) (Optical Society of America, 2018), paper M2B.3.
- [18] R. V. Der Linden, N. C. Tran, E. Tangdionga and A. M. J. Koonen, "Increasing flexibility and capacity in real PON deployments by using 2/4/8-PAM formats," in IEEE/OSA Journal of Optical Communications and Networking, vol. 9, no. 1, pp. A1-A8, Jan. 2017.
- [19] C. Caillaud *et al.*, "Integrated SOA-PIN Detector for High-Speed Short Reach Applications," in Journal of Lightwave Technology, vol. 33, no. 8, pp. 1596-1601, April15, 15 2015.
- [20] B. Glance, "Polarization independent coherent optical receiver," J. Lightw. Technol., vol. LT-5, no. 2, pp. 274-276, Feb. 1987.
- [21] J. A. Altabas *et al.*, "Real-time 10Gbps Polarization Independent Quasi-coherent Receiver for NG-PON2 Access Networks," in Optical Fiber Communication Conference, OSA Technical Digest (online) (Optical Society of America, 2018), paper Th1A.3.
- [22] E. Ciaramella, "Polarization-Independent Receivers for Low-Cost Coherent OOK Systems," in IEEE Photonics Technology Letters, vol. 26, no. 6, pp. 548-551, March15, 2014.
- [23] M. G. Saber *et al.*, "DSP-free 25 Gbit/s PAM-4 Transmission using 10G Transmitter and Coherent Amplification," to appear in IEEE Photonics Technology Letters (preprint).
- [24] H. Mardoyan *et al.*, "204-Gbaud On-Off Keying Transmitter for Inter-Data Center Communications," in Optical Fiber Communication Conference, OSA Technical Digest (online) (Optical Society of America, 2018), paper Th4A.4.
- [25] M. H. Eiselt, N. Eiselt, and A. Dochhan, "Direct Detection Solutions for 100G and Beyond," in Optical Fiber Communication Conference, OSA Technical Digest (online) (Optical Society of America, 2017), paper Tu3I.3.
- [26] J. Zhang *et al.*, "Symmetrical 50-Gb/s PAM-4 TDM-PON in O-band with DSP and Semiconductor Optical Amplifier Supporting PR-30 Link Loss Budget," in Optical Fiber Communication Conference, OSA Technical Digest (online) (Optical Society of America, 2018), paper M1B.4.
- [27] M. Morsy-Osman *et al.*, "DSP-free 'coherent-lite' transceiver for next generation single wavelength optical intra-datacenter interconnects," Opt. Express 26, pp. 8890-8903 (2018).
- [28] Z. Liu, T. Xu, G. Saavedra, and P. Bayvel, "448-Gb/s PAM4 Transmission Over 300-km SMF-28 Without Dispersion Compensation Fiber," in Optical Fiber Communication Conference, OSA Technical Digest (online) (Optical Society of America, 2018), paper W1J.6.
- [29] T. Gerard *et al.*, "A Low-Loss Split-Carrier Transmitter Architecture for Intra-Datacenter Communications," In Proceedings ECOC 2018: 44th European Conference on Optical Communication, 23-27 September 2018 paper We2.53
- [30] A. Mecozzi *et al.*, "Kramers-Kronig coherent receiver," Optica 3, 1220 (2016).
- [31] D. Li *et al.*, "Bidirectional long-reach PON using Kramers-Kronig-based receiver for Rayleigh Backscattering noise and SSBI interference elimination," Opt. Express 26, 19020-19036 (2018)
- [32] Z. Li *et al.*, "Joint Optimisation of Resampling Rate and Carrier-to-Signal Power Ratio in Direct-Detection Kramers-Kronig Receivers," In Proc. 2017 European Conference on Optical Communication (ECOC), Gothenburg, 2017, pp. 1-3.
- [33] B. Schrenk and F. Karinou, "Worlds First TO-can Coherent Transceiver," in Optical Fiber Communication Conference, OSA Technical Digest (online) (Optical Society of America, 2018), paper Th1A.4.
- [34] I. N. Cano, A. Lern, V. Polo and J. Prat, "Polarization independent single-PD coherent ONU receiver with centralized scrambling in udWDM-PONs," 2014 The European Conference on Optical Communication (ECOC), Cannes, 2014, paper P.7.12.
- [35] M. S. Erkilinç *et al.*, "Bidirectional symmetric 8x10.7Gb/s WDM-PON over 108 km installed fiber using low complexity polarization-insensitive coherent ONUs," M1.E2 in Proc. European Conference on Optical Communication 2016.
- [36] D. Lavery, S. Erkilinç, P. Bayvel and R. I. Killey, "Recent Progress and Outlook for Coherent PON," 2018 Optical Fiber Communications Conference and Exposition (OFC), San Diego, CA, 2018, pp. 1-3.
- [37] M. S. Erkilinç *et al.* "Bidirectional Symmetric 25G Coherent ONU Using a Single Laser, Single-ended PIN and a 2-bit ADC," paper We2.67 in Proceedings of European Conference on Optical Communications.
- [38] I. G. López, P. Rito, A. C. Ulusoy, A. Awny and D. Kissinger, "PAM-4 receiver with integrated linear TIA and 2-bit ADC in 0.13 m SiGe:C BiCMOS for high-speed optical communications," 2017 IEEE MTT-S International Microwave Symposium (IMS), Honolulu, HI, 2017, pp. 582-585.
- [39] S. Y. Kim, T. Suzuki, J. i. Kani, A. Otaka and T. Hanawa, "Coherent Receiver DSP Implemented on a General-Purpose Server for Full Software-Defined Optical Access," 2018 Optical Fiber Communications Conference and Exposition (OFC), San Diego, CA, 2018, pp. 1-3.
- [40] D. Lavery, L. Galdino, Z. Liu, S. Erkilinç and P. Bayvel, "A 32x10 Gb/s OLT using a single ultra-wide bandwidth dual local oscillator coherent receiver," 2017 IEEE Photonics Conference (IPC) Part II, Orlando, FL, 2017, pp. 1-2
- [41] D. Lavery, C. Behrens, and S. J. Savory, "On the Impact of Backreflections in a Bidirectional 10 Gbit/s Coherent WDM-PON," paper OTh1F.3 in Proceedings of Optical Fiber Communication Conference 2012
- [42] D. Lavery, M. Paskov, S.J. Savory, "Spectral Shaping for Mitigating Backreflections in a Bidirectional 10 Gbit/s Coherent WDM-PON," OM2A.6 in Proceedings of Optical Fiber Communication Conference 2013.
- [43] J. D. Reis *et al.*, "Terabit+ (192x10 Gb/s) Nyquist Shaped UDWDM Coherent PON With Upstream and Downstream Over a 12.8 nm Band," in Journal of Lightwave Technology, vol. 32, no. 4, pp. 729-735, 2014.
- [44] K. Kikuchi and S. Tsukamoto, "Evaluation of Sensitivity of the Digital Coherent Receiver," in Journal of Lightwave Technology, vol. 26, no. 13, pp. 1817-1822, 2008.
- [45] S. C. Davies *et al.*, "Narrow linewidth, high power, high operating temperature digital supermode distributed Bragg reflector laser," paper Th.1.B.3 in Proc. European Conference on Optical Communication 2013.
- [46] D. Lavery *et al.*, "Reduced Complexity Equalization for Coherent Long-Reach Passive Optical Networks [Invited]," J. Opt. Commun. Netw. 7, A16-A27 (2015).