

# W-band Radio-over-fiber Link Based on Self-oscillating Optical Frequency Comb Generator

G.K.M. Hasanuzzaman<sup>1</sup>, Atsushi Kanno<sup>2</sup>, Pham Tien Dat<sup>2</sup> and Stavros Iezekiel<sup>1\*</sup>

<sup>1</sup>Microwave Photonics Research Laboratory, Department of Electrical and Computer Engineering, University of Cyprus, 1678, Nicosia, Cyprus

<sup>2</sup>Network System Research Institute, National Institute of Information and Communication Technology, Tokyo 184-8795, Japan  
*ghasan01@ucy.ac.cy, kanno@nict.go.jp, ptdat@nict.go.jp, iezekiel@ucy.ac.cy\**

**Abstract:** A 94.8 GHz radio-over-fiber link was implemented with a self-oscillating frequency comb. An LTE Advanced OFDM FDD 64-QAM signal of 20 MHz bandwidth was transmitted over 1.3 m wireless distance with an EVM of 2.23%.

**OCIS codes:** (060.5625) Radio frequency photonics; (060.2840) Heterodyne; (230.0250) Optoelectronics; (350.4010) Microwave.

## 1. Introduction

Two of the most useful microwave photonics-based sources are the optoelectronic oscillator (OEO) and the optical frequency comb generator (OFCG). The former (OEO) provides very high spectral purity signals as both microwave and optical outputs [1], while the latter (OFCG) is a convenient way to generate phase correlated and accurately spaced optical tones with many applications, including millimeter-wave and THz signal generation, generation of optical multi-carriers, optical signal processing and optical coherence tomography [2-3]. Typically, a recirculating delay line-based OFCG relies on an external microwave oscillator to provide the seed tone, but in recent work this has been replaced with OEOs, resulting in self-oscillating optical frequency comb generators (SOFCG) [3-4]. One advantage is that the OEO has superior phase noise performance compared to commercial microwave synthesizers, which in turn means that the SOFCG is able to generate low phase noise millimeter-wave and THz waves compared to conventional OFCGs. This is due to the use of high-Q optical storage elements (such as long fibers or whispering gallery mode resonators).

In recent years optical frequency combs have been used in radio-over-fiber systems (RoF) [5-7], where they have the advantage of forming multiple carriers. However, to the best of our knowledge the use of SOFCG in RoF systems has not been attempted to date.

Here, we propose and experimentally demonstrate a RoF link based on a SOFCG for photonic generation of millimeter-wave signals. A proof-of-concept system using a dual-loop OEO architecture shows that up to 23 comb lines with a frequency spacing of 11.84 GHz can be generated; by selecting two comb lines, it is possible in principle to generate (through heterodyning) a mm-wave signal up to 260.48 GHz. A RoF link operating at W band (94.8 GHz) has been implemented, in which an LTE Advanced (LTE-A) downlink signal centered at 1 GHz with a bandwidth of 20 MHz and 64-QAM was transmitted over a 1.3 m wireless link with an error vector magnitude (EVM) as low as 2.35%. A throughput of 100 Mbps was achieved in the physical layer without any overhead.

## 2. Experimental set-up

The proof-of-concept experimental set-up is shown in Fig.1. A fiber laser (FL) of 15 Hz linewidth and 13 dBm output power at 1550.22 nm is used as a continuous-wave optical source for a dual drive Mach-Zehnder modulator (DDMZM). The DDMZM functions both as the E/O converter for the OEO loop and as a frequency comb generator. For the latter function, we used the technique in [8] to generate the optical frequency comb, with the RF input being formed from the OEO loop instead of an external microwave source. The output of the DDMZM is then amplified by an erbium-doped fiber amplifier (EDFA) and split into two paths by a 50:50 coupler. One output is used to close the OEO loop, and the other is used for optical two-tone generation and data modulation for the RoF link. A dual loop balanced detection configuration is used in the feedback loop of the OEO, with short and long fiber lengths of  $L_1 = 2$  m and  $L_2 = 2$  km respectively, which then feed a balanced photodiode (Finisar BPDV2150R, with a 3-dB bandwidth of 43 GHz and responsivity of 0.45 A/W). A microwave band pass filter (EBPF) (Tamagawa SBF-203 BPF with a 3-dB bandwidth of 300 MHz) is used to select desired RF signal. The filtered signal is then amplified by a low noise amplifier (SHF 806E with 26 dB gain) prior to a RF power splitter, one output of which is connected to the RF port of the DDMZM to close the OEO loop and the other is connected to the electrical signal analyzer (Agilent N9030A PXA) for monitoring the spectrum and measuring the phase noise performance.

After passing through a 95:5 coupler (for optical spectrum monitoring with a Yenista Optics OSA-20 with a resolution of 0.02 nm), the other output of the first 50:50 coupler is used for optical two-tone generation and data modulation. A Finisar waveshaper (16000S) is used to select two comb lines (spaced by 94.8 GHz) and route them

into two different output ports. One of these output tones is fed into a MZM for modulation with an LTE-A standard downlink signal centered at 1 GHz with a bandwidth of 20MHz and modulation format 64 QAM generated from an Agilent PSG vector signal generator (E8267D).

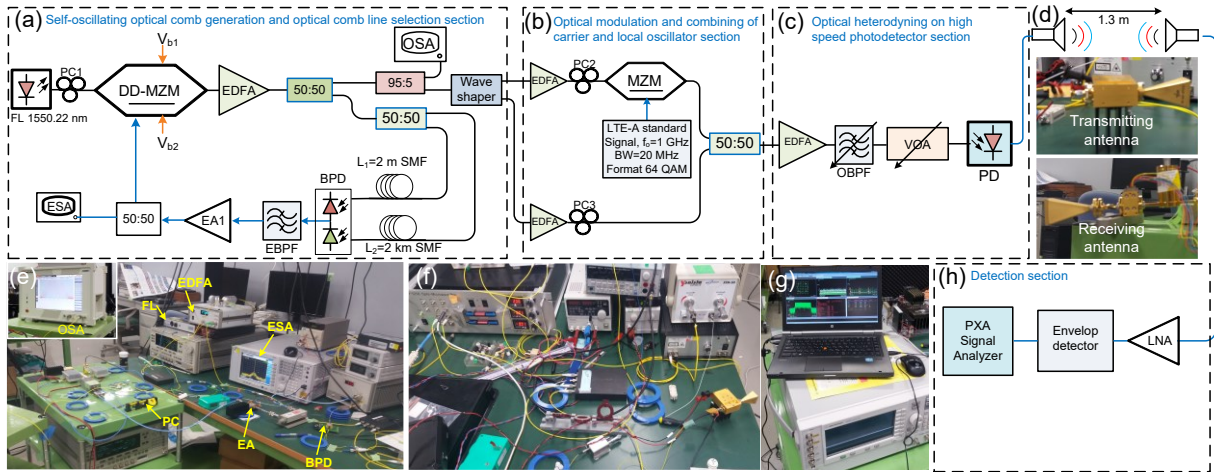

Fig. 1: Experimental setup of the SOFCG based radio over fiber link. (a) schematic diagram of SOFCG (b) optical modulation and combining of carrier and local oscillator (c) optical heterodyning on high speed photodetector (d) wireless section (e) photo of OFCG section (f) photo of optical modulation and heterodyning section (g) DSP processing (h) detection section. The optical path and electrical path are represented by black line and blue line respectively.

This is combined with the other optical tone for subsequent mm-wave signal generation. The combined two tone signal is then amplified by an EDFA; filtered by a 1 nm tunable optical band pass filter to remove the out-of-band amplified spontaneous emission (ASE); and adjusted by a variable optical attenuator (VOA) to control the input optical power before heterodyning in a high speed photodiode (Finisar XPDV4120R). The output of the photodetector is connected to a horn antenna with a 23 dBi gain and propagated over a 1.3 m wireless link. A second identical horn antenna placed in the same polarization is used to receive the radiated signal. The received W band signal is then amplified and down converted by an envelope detector and analyzed by a signal analyzer (Agilent N9030A PXA).

### 3. Results and discussion

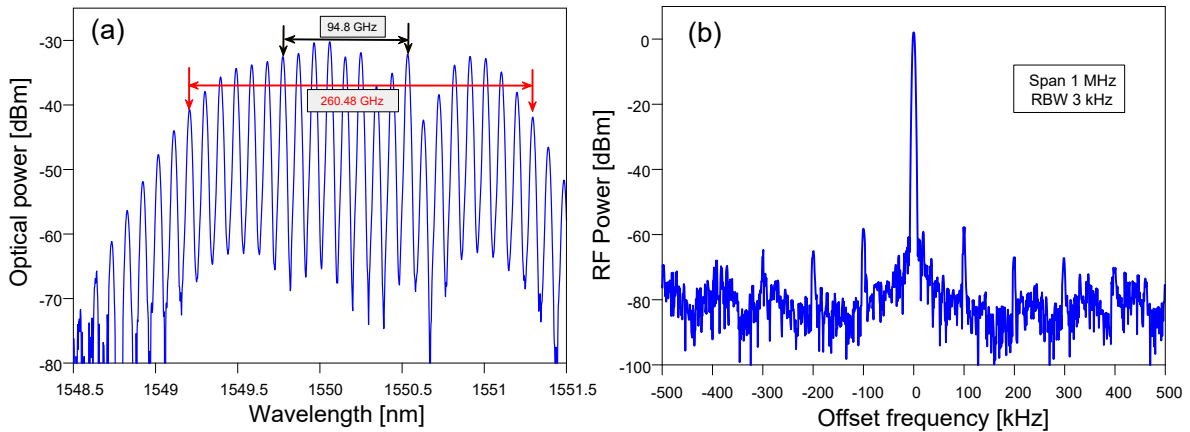

Fig.2: (a) Optical spectrum of the generated optical 23-line optical frequency comb with a frequency spacing of 11.84 GHz at the center wavelength of 1550.22 nm (measured at OSA in Fig. 1(a)). (b) Electrical spectrum of the generated signal (measured at ESA in Fig. 1(a)).

The optical spectrum of the generated comb lines from the SOFCG section is shown in Fig. 2(a). The comb spacing is 11.84 GHz which corresponds to the oscillation frequency of the OEO loop, and 23 comb lines are generated. Figure 2(b) shows the electrical spectrum of the 11.84 GHz oscillation generated by the OEO loop; the single side band (SSB) phase noise of the generated oscillation was measured by the phase noise measurement functionality of the signal analyzer. The measured SSB phase noise of the OEO is compared with a commercial microwave source (HP 83620A) in Fig. 3(a). The SSB phase noise of the 11.84 GHz signal at a 10 kHz offset is much lower for the OEO (-110 dBc/Hz) than for the HP 83620A (-88 dBc/Hz).

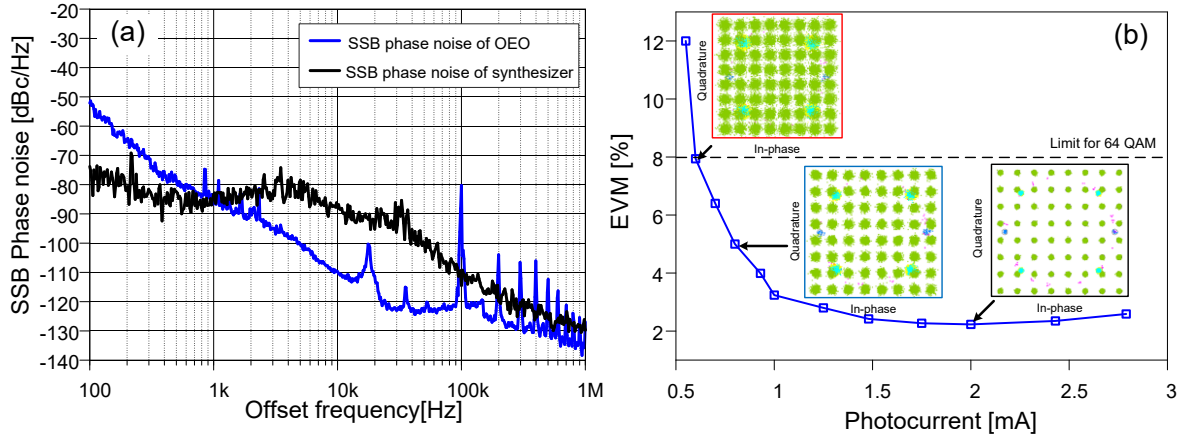

Fig. 3: (a) SSB phase noise of the 11.84 GHz oscillation obtained by OEO (blue line). SSB phase noise of HP 83620A synthesizer (black line) (b) EVM vs photocurrent of the transmission system. The insets are the constellation diagram of (64 QAM OFDM signal, 1.3 m wireless transmission distance).

The measured EVM is plotted against photocurrent ( $I_p$ ) in Fig. 3(b) for a transmitted LTE-A 64 QAM signal over a 1.3 m wireless distance. A variable optical attenuator in front of the photodiode is used to adjust the incident optical power and hence the generated  $I_p$ . The obtained EVMs are 2.23% at  $I_p = 2$  mA. For values of  $I_p$  above 2 mA, the EVM increases due to the saturation effect in the amplifier stage at the receiver as shown in Fig. 3(b). The measured EVMs are degraded by 45% for a 50% reduction of  $I_p$ . The insets show the corresponding constellation diagrams.

#### 4. Conclusion

We demonstrated a self-oscillating optical frequency comb generator and used this to implement a radio-over-fiber link at 94.8 GHz. The SOFCG provides 23 comb lines with 11.84 GHz spacing that can potentially generate mm-waves up to 260 GHz. The SSB phase noise of the 11.84 GHz oscillation is -110 dBc/Hz at a 10 kHz offset. An LTE Advanced standard 64 QAM signal was sent over a wireless path of 1.3 m with an EVM as low as 2.35%.

#### 5. Acknowledgement

This project has received funding from the European Union's Horizon 2020 research and innovation programme under the Marie Skłodowska-Curie grant agreement No. 642355. G.K.M Hasanuzzaman also thanks the National Institute of Information and Communication Technology (NICT), Japan for providing a research internship.

#### 6. References

- [1] X. S. Yao and L. Maleki, "Optoelectronic microwave oscillator," J. Opt. Soc. Am. B **13**, 1725 (1996).
- [2] D. Hillerkuss, T. Schellinger, M. Jordan, C. Weimann, F. Parmigiani, B. Resan, K. Weingarten, S. Ben-Ezra, B. Nebendahl, C. Koos, W. Freude, and J. Leuthold, "High-quality optical frequency comb by spectral slicing of spectra broadened by SPM," IEEE Photonics J. **5**, (2013).
- [3] M. Wang and J. Yao, "Tunable optical frequency comb generation based on an optoelectronic oscillator," IEEE Photonics Technol. Lett. **25**, 2035–2038 (2013).
- [4] J. Dai, X. Xu, Z. Wu, Y. Dai, F. Yin, Y. Zhou, J. Li, and K. Xu, "Self-oscillating optical frequency comb generator based on an optoelectronic oscillator employing cascaded modulators," Opt. Express **23**, 30014 (2015).
- [5] S. Koenig, D. Lopez-Diaz, J. Antes, F. Boes, R. Henneberger, A. Leuther, A. Tessmann, R. Schmogrow, D. Hillerkuss, R. Palmer, T. Zwick, C. Koos, W. Freude, O. Ambacher, J. Leuthold, and I. Kallfass, "Wireless sub-THz communication system with high data rate," Nat. Photonics **7**, 977–981 (2013).
- [6] H. Shams, T. Shao, M. J. Fice, P. M. Anandarajah, C. C. Renaud, F. Van Dijk, L. P. Barry, and A. J. Seeds, "100 Gb/s multicarrier THz wireless transmission system with high frequency stability based on a gain-switched laser comb source," IEEE Photonics J. **7**, (2015).
- [7] A. Kanno, P. T. Dat, N. Sekine, I. Hosako, and T. Kawanishi, "High-Speed Coherent Transmission Using Advanced Photonics in Terahertz Bands," IEICE Transactions on Electronics, **98**, 1071–1080 (2015).
- [8] T. Sakamoto, T. Kawanishi, and M. Izutsu, "Asymptotic formalism for ultraflat optical frequency comb generation using a Mach-Zehnder modulator," Opt. Lett. **32**, 1515–1517 (2007).