

Multicore Fiber Based mm-wave Generation, Radio over-Fiber and Power-over-Fiber

G. K.M. Hasanuzzaman, Stavros Iezekiel

Microwave Photonics Research Laboratory

Department of Electrical and Computer Engineering, University of Cyprus

1678 Nicosia, Cyprus

iezekiel@ucy.ac.cy

Abstract— We propose a multi-core fiber (MCFs) based concept which simultaneously use to generate millimeter wave (mm-wave) signal; a radio over fiber link; and a power over fiber link. In the proposed system, some cores of MCFs are used to generate mm-wave signal using an optoelectronic oscillator (OEO) topology, few of the cores are used to transport data modulated mm-wave signal through radio-over-fiber (RoF) technology while others are used to transmit optical power for biasing the amplifier in the remote antenna unit with help of power over fiber (PoF) technology and photonic power converter in a small cell architecture of the future 5G technology.

Keywords—Multi-core fiber; mm-wave generation; radio-over-fiber; power-over-fiber.

I. INTRODUCTION

A number of technologies have been considered in order to meet the demand for high wireless and wireline data rates with low latency. These include mm-wave radio-over-fiber (RoF), distributed antenna systems (DAS) in micro- or nanocell architectures, and spatial division multiplexing (SDM) using multicore fiber (MCF) [1][2].

In both RoF and DAS micro- and nanocell access networks, a key need is to have remote antenna units (RAU) of small footprint, low complexity, low cost and low power consumption. For the latter requirement, zero-biased untravelling carrier photodiodes (UTC-PD) and the delivery of power-over-fiber (PoF) help to eliminate the use of electrical supply lines and also lead to simpler RAU architectures. PoF is an emerging technology where electrical power is transmitted over fiber to/from a remote location with the aid of photonic power converters (PPC) and high power laser diodes [3]. Initially, PoF was considered for on-line monitoring systems in high voltage power lines and for improving lightning protection of microwave radio equipment [4]. More recently however, PoF technology was demonstrated in a MCF-based RoF link to bias the microwave components of a RAU in a microcell architecture as shown in Fig.1. In [5] an optical link feeding 60W along with bidirectional radio over fiber was demonstrated.

Generation of spectrally pure microwave and mm-wave carrier signals is also a key aspect of high speed data links since higher phase noise introduces jitter and results in a high error vector magnitude (EVM). Optoelectronic oscillators

(OEO) can provide low phase noise microwave and mm-wave oscillation, with the phase noise being independent of the oscillation frequency since it is controlled by the high Q energy storage element in the OEO loop [6]. The state of the art OEO can provide a carrier with a phase noise as low as -163 dBc/Hz at an offset frequency of 6 kHz [7]. Recently MCF has been proposed for implementing a multi-loop OEO topology in [8] and experimentally demonstrated in [9] with a phase noise of -85 dBc/Hz at a 10-kHz offset from a 4.494 GHz carrier.

In this paper, we extend the above concepts by proposing the use of a single MCF to implement three key functions, namely: (i) an OEO for low phase noise mm-wave generation (ii) radio over fiber link for providing high capacity low latency access network and (iii) power over fiber for biasing the RAU.

II. PROPOSED MCF ARCHITECTURE

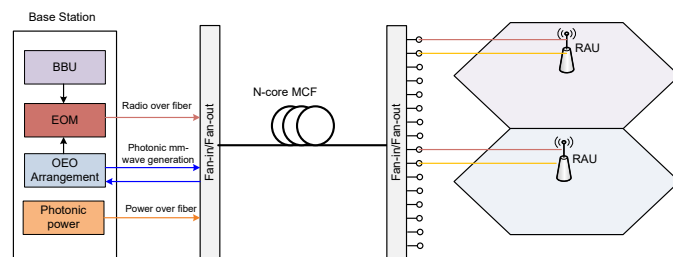

Fig. 1: Conceptual illustration of MCF-based mm-wave generation, RoF link and PoF. (BBU: Base band unit, RAU: Remote antenna unit, EOM: Electro-optic modulator, OEO: Optoelectronic oscillator)

The proposed architecture for the simultaneous generation of a microwave carrier, its subsequent implementation in a RoF link and the use of PoF for this link is shown in Fig. 2. Here a 9-core MCF is used to illustrate the concept for a single microcell; six of these cores are used to implement a dual-loop OEO, two are allocated to PoF and the final core is employed for the RoF link. The number of cores depends on the number of cells by the relation $6+2N$, where N is the number of microcells. Generally, a large mode area (LMA) fiber provides better performance in power over fiber transmission. However, more recently a conventional 7-core MCF (45- μm pitch) has been considered to transmit power and radio simultaneously [10][11]. Referring to Fig.2, the optical

signal from a fiber laser (FL) is fed to a dual drive Mach-Zehnder modulator (DD-MZM), which functions both as an optical frequency comb generator (OFCG) for optical multi-tone generation and an E/O converter for the OEO loop. After being amplified by an erbium doped fiber amplifier (EDFA), the optical comb passes through a programmable wavelength selective switch (WSS) where four comb lines are selected and then diverted to four different output ports. Of these, two tones (port-1 and port-2 of the WSS) are used for the dual-loop OEO loop, in which the short loop (L_1) comprises two cores (core-4 and core-5) while the long loop (L_2) is formed from four cores (cores 3, 6, 7, and 8). In order to implement the short loop (L_1) the output from core-5 is connected to core-4 in lower fan-in/fan-out module. For the long loop, the output from core-8 is connected to core-7, the output from core-7 is connected to core-6 and finally the output from core-6 is connected to core-3. The outputs from core-3 and core-4 are then connected to the two input ports of a balanced photodetector (BPD). The photodetected signal is then amplified and filtered by an electrical amplifier and bandpass filter respectively. Prior to connecting to the DD-MZM for completing the optoelectronic loop, the electrical signal is divided into two by an 180-degree hybrid. Two electrical phase shifter is placed after the 180-degree to obtain the flat comb condition described in [12]. Through appropriate biasing and phase condition the

optoelectronic loop can be configured to act as a self-oscillating comb generator [13]. A dual-loop balanced detection scheme helps to overcome the limitation of a small microwave free spectral range (FSR) that single-loop OEOs suffer from, and balanced photodetection helps to reduce the impact of RIN induced from the fiber laser. The length of the multicore fiber plays some important role on the performance of the generated electrical carrier e.g. the phase noise and the side mode suppression ratio (SMSR). Increasing the fiber length enhance the quality factor and reduces the phase noise of the oscillating signal [6].

$$Q = \frac{2\pi f_0 \tau_d^2}{\delta} \quad (1)$$

where f_0 is the frequency of the oscillation, τ_d is the delay induced by the optical fiber which is proportional to the length of the fiber and δ is the signal to noise ratio after photo-detection in the OEO loop. However, chromatic dispersion of the fiber also degrades the phase noise of the oscillation as indicated by the following equation [14].

$$\delta\psi = 2\pi f_0 \lambda_0^2 D_\lambda \frac{L}{c} \delta\nu \quad (2)$$

where $\delta\psi$ is the phase fluctuation induced due to chromatic dispersion, f_0 is the oscillation frequency, D_λ is the fiber chromatic dispersion, L is the length of the fiber, c is the speed

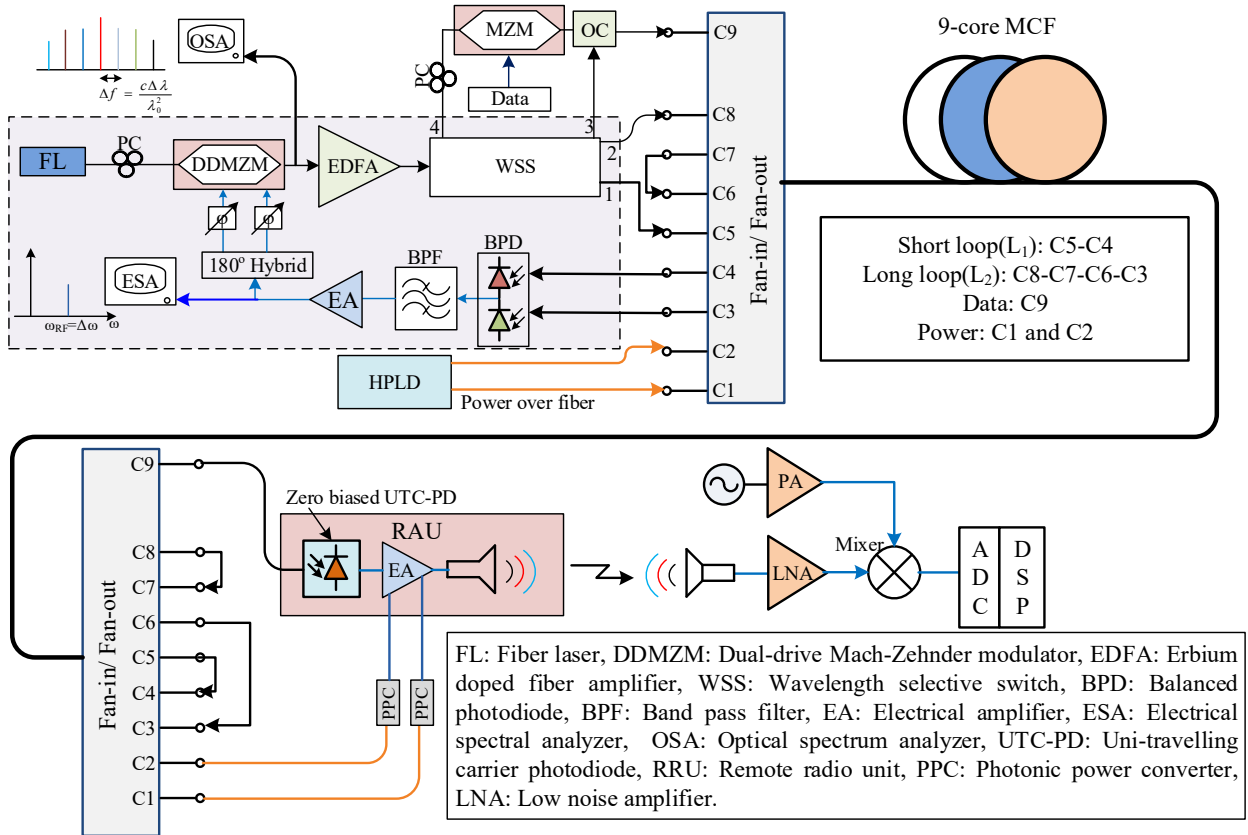

Fig.2: Schematic structure of multicore fiber based microwave and millimeter wave generation, radio over fiber link and power over fiber link. The optical and electrical paths are indicated by black and blue lines respectively. The orange lines indicate the power over fiber link.

of the light and $\delta\nu$ is the laser linewidth. Additionally, the chromatic dispersion induced power fading also limits the fiber length (L) [15] at a specific frequency of oscillation. Therefore, the MCF length selection depends on the dispersion of the fiber, phase noise requirement of the system, bandwidth of the electrical filter in the OEO loop, and distance from the base station to remote radio unit.

The other two tones selected by the WSS (at port 3 and port 4) are used for mm-wave generation (via heterodyning at the RAU) and data modulation as shown in Fig.2. A MZM is used for data modulation and an optical coupler (OC) is then used to combine the modulated tone with the other CW tone. Then the combined signal is propagated through core-9 of the MCF and heterodyne detected in a zero-biased UTC-PD. The photodetected mm-wave signal is then amplified before wireless propagation via the antenna. The amplifier in the remote radio unit is biased through the photonic power converted signal which is transmitted to the RAU using core-1 and core-2 of the MCF as illustrated in Fig.2. A second identical antenna of the same polarization is used to receive the transmitted signal mm-wave signal. Subsequently the received signal is amplified by a low noise amplifier, down-converted by a mixer and analyzed with a digital signal processor (DSP).

III. CONCLUSION

In this paper, we have outlined the proposed implementation of a MCF to simultaneously implement three key functions in microwave photonics, viz.: (i) an OEO for low phase noise mm-wave generation (ii) radio over fiber link for providing high capacity low latency access network and (iii) power over fiber for biasing the RAU. Such an approach has the potential to simplify the remote radio unit in future microcell based communication technology.

IV. ACKNOWLEDGEMENT

This project has received funding from the European Union's Horizon 2020 research and innovation programme under the Marie Skłodowska-Curie grant agreement No. 642355.

V. REFERENCES

[1] K. Saitoh and S. Matsuo, "Multicore fiber technology," *J. Light. Technol.*, vol. 34, no. 1, pp. 55–66, 2016.

[2] G. K. M. Hasanuzzaman *et al.*, "Performance Enhancement of Multi-Core Fiber Transmission Using Real-Time FPGA Based Pre-Emphasis," in *[ACP] Asia Communications and Photonics Conference*, p. M2H.1.

[3] T. Umezawa *et al.*, "100-GHz Fiber-Fed Optical-To-Radio Converter for Radio-And Power-Over-Fiber Transmission," *IEEE J. Sel. Top. Quantum Electron.*, vol. 23, no. 3, 2017.

[4] K. Ikeda, "Lightning protection of microwave radio equipment using radio on fiber and power over fiber experimental demonstration of communication quality," *2014 Int. Top. Meet. Microw. Photonics / 9th Asia-Pacific Microw. Photonics Conf. MWP/APMP 2014 - Proc.*, pp. 185–188, 2014.

[5] M. Matsuura, H. Furugori, and J. Sato, "60 W power-over-fiber feed using double-clad fibers for radio-over-fiber systems with optically powered remote antenna units," *Opt. Lett.*, vol. 40, no. 23, pp. 5598–5601, 2015.

[6] X. S. Yao and L. Maleki, "Optoelectronic microwave oscillator," *J. Opt. Soc. Am. B*, vol. 13, no. 8, p. 1725, 1996.

[7] D. Eliyahu, D. Seidel, and L. Maleki, "Phase noise of a high performance OEO and an ultra low noise floor cross-correlation microwave photonic homodyne system," in *2008 IEEE International Frequency Control Symposium, FCS*, 2008, pp. 811–814.

[8] S. García and I. Gasulla, "Multi-cavity optoelectronic oscillators using multicore fibers," *Opt. Express*, vol. 23, no. 3, pp. 2403–15, 2015.

[9] S. García and I. Gasulla, "Experimental demonstration of multi-cavity optoelectronic oscillation over a multicore fiber," *Opt. Express*, vol. 25, no. 20, pp. 23663–23668, 2017.

[10] T. Umezawa, P. T. Dat, A. Kanno, and N. Yamamoto, "110 GHz zero-bias based UTC-PD for radio-over-fiber transmission through multicore fiber," in *2017 IEEE Photonics Conference (IPC)*, 2017, pp. 97–98.

[11] U. Toshimasa, P. T. Dat, K. Kashima, A. Kanno, N. Yamamoto, and T. Kawanishi, "100-GHz Radio and Power Over Fiber Transmission Through Multicore Fiber Using Optical-to-Radio Converter Toshimasa," *J. Light. Technol.*, vol. 36, no. 2, pp. 617–623, 2018.

[12] T. Sakamoto, T. Kawanishi, and M. Izutsu, "Asymptotic formalism for ultraflat optical frequency comb generation using a Mach-Zehnder modulator," *Opt. Lett.*, vol. 32, no. 11, pp. 1515–1517, 2007.

[13] G. K. M. Hasanuzzaman, A. Kanno, P. T. Dat, and S. Iezekiel, "W-band radio-over-fiber link based on self-oscillating optical frequency comb generator," in *Optical Fiber Communication Conference*, 2018, p. paper W1F.6.

[14] K. Volyanskiy, Y. K. Chembo, L. Larger, and E. Rubiola, "Contribution of laser frequency and power fluctuations to the microwave phase noise of optoelectronic oscillators," *J. Light. Technol.*, vol. 28, no. 18, pp. 2730–2735, 2010.

[15] G. H. Smith, "Overcoming chromatic-dispersion effects in fiber-wireless systems incorporating external modulators," *IEEE Trans. Microw. Theory Tech.*, vol. 45, no. 8 PART 2, pp. 1410–1415, 1997.