

Is angiotensin-(3–4) (Val-Tyr), the shortest angiotensin II-derived peptide, opening new vistas on the renin–angiotensin system?

Journal of the Renin–Angiotensin–Aldosterone System
January–March 2017: 1–7
© The Author(s) 2017
Reprints and permissions:
sagepub.co.uk/journalsPermissions.nav
DOI: 10.1177/1470320316689338
journals.sagepub.com/home/jra

Juliana Dias^{1,2,3}, Flavia Axelband¹, Lucienne S. Lara^{3,4},
Humberto Muzi-Filho^{2,3} and Adalberto Vieyra^{2,3,5}

Abstract

Angiotensin-(3–4) (Ang-(3–4) or Val-Tyr) is the shorter angiotensin (Ang) II-derived peptide, formed through successive hydrolysis that culminates with the release of Val-Tyr as a dipeptide. It is formed both in plasma and in kidney from Ang II and Ang III, and can be considered a component of the systemic and organ-based renin–angiotensin system. It is potently antihypertensive in humans and rats, and its concerted actions on proximal tubule cells culminate in the inhibition of fluid reabsorption, hyperosmotic urinary excretion of Na⁺. At the renal cell signaling level, Ang-(3–4) counteracts Ang II-type I receptor-mediated responses by acting as an allosteric enhancer in Ang II-type 2 receptor populations that target adenosine triphosphate-dependent Ca²⁺ and Na⁺ transporters through a cyclic adenosine monophosphate-activated protein kinase pathway.

Keywords

Ang-(3–4), local renal RAS, AT₁R/AT₂R heterodimer dissociation, cyclic adenosine monophosphate-dependent protein kinase, Na⁺-ATPase, hyperosmotic urinary Na⁺ excretion, antihypertensive action

Date received: 17 October 2016; accepted: 15 December 2016

Introduction

During the past three decades research has progressively shown a new and fascinating world behind the century-old history of the pressoric renin–angiotensin system (RAS), discovered in several seminal steps between 1898¹ and 1941.^{2–7} The new world is that of shorter peptides originating from both the decapeptide angiotensin I (Ang I) and the octapeptide angiotensin II (Ang II),⁸ with Ang-(1–7) being the best known in terms of physiological effects and intracellular signaling pathways (reviewed in Alenina and Santos).⁹ Interestingly, this early representative of the Ang I/Ang II-derived peptides soon emerged as a potent counterbalance to the vasoconstrictive actions of RAS.

In parallel with the discovery of the structure and actions of the shorter Ang I/Ang II-derived peptides, the simple and earlier view of RAS as a classic endocrine system shifted to a dual concept involving the coexistence of the systemic RAS – mainly regarding cardiovascular actions – with the so-called organ-based RAS.¹⁰ In this system described in heart,¹¹ kidney,¹² brain¹³ and liver,¹⁴ among other organs, the main event is the local formation of Ang

II.¹⁵ Interestingly, crosstalk between different local RAS systems has physiological and pathological relevance for heart and kidney.¹⁶ Even though the ‘organ uptake theory’ dominated this new view of RAS because it could explain the significant amounts of Ang II found in several organs/tissues,¹⁷ the concept was soon expanded to include genes involved in the synthesis of renin,^{18,19} precursors such as

¹National Institute of Cancer, Rio de Janeiro, Brazil

²Carlos Chagas Institute of Biophysics, Federal University of Rio de Janeiro, Brazil

³National Center of Structural Biology and Bioimaging, Federal University of Rio de Janeiro, Brazil

⁴Institute of Biomedical Sciences, Federal University of Rio de Janeiro, Brazil

⁵Translational Biomedicine Graduate Program, Grande Rio University, Brazil

Corresponding author:

Adalberto Vieyra, Carlos Chagas Institute of Biophysics, Federal University of Rio de Janeiro, Rio de Janeiro, Brazil.
Email: avieyra@biof.ufrj.br



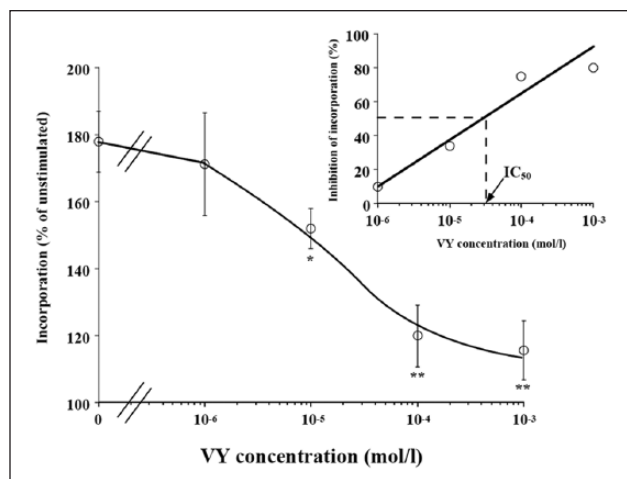

Figure 1. Proliferation of angiotensin II (Ang II)-stimulated vascular smooth muscle cells is inhibited by angiotensin-(3–4) (Ang-(3–4)) (represented by VY) in a dose-dependent manner. This figure shows WST-8 reduction by nicotinamide adenine dinucleotide (NADH) in the presence of 1 $\mu\text{mol/L}$ Ang II and increasing concentrations of Ang-(3–4). The inset shows that antiproliferative action of Ang-(3–4) has a 50% inhibitory concentration (IC_{50}) in the micromolar range. Reproduced from Matsui et al.,²⁸ with permission.

angiotensinogen^{11,20} and enzymes (from renin to the angiotensin II-converting enzymes, ACE and ACE2).^{8,21,22} These components were encountered in many different organs, together with local Ang II concentrations significantly higher than those of the circulating peptide.²³

Angiotensin-(3–4)

Moving on beyond Ang-(1–7) to the myriad of very short Ang I/Ang II-derived peptides, their formation and their potential functional role were first described in animal and plant tissues and their effects were demonstrated using extracts of these tissues.^{24,25} One of the shorter peptides that was soon identified for its important physiological relevance was the dipeptide angiotensin-(3–4) (Ang-(3–4) or Val-Tyr). Ang-(3–4) was first purified from rice extracts (sake)²⁵ and promptly assayed for cardiovascular actions.^{26,27} Earlier work on isolated luminal proximal tubule membranes and Ang II provided evidence that Ang-(3–4) was a metabolite of local renal RAS.⁸ In plasma, Ang-(3–4) can be formed from angiotensin III (Ang III),²⁷ thus making it a component of both the local and systemic RAS.

A few reports indicated that Ang-(3–4) had significant physiological effects in cardiovascular homeostasis. As well as its clear inhibitory effect of ACE *in vitro*,²⁷ Ang-(3–4) was antiproliferative in cultured smooth muscle cells²⁸ (Figure 1), and had vasodilatory effects on the aorta in hypertensive and non-hypertensive rats.^{29,30} These vascular antagonistic actions with Ang II could also be helped by its free radical reducing and scavenging ability,³⁰ which

can be related to the very hydrophobic nature of its molecular moiety.³¹ Interestingly, Ang-(3–4) is effective when administered orally,^{26,32,33} a property associated with its resistance to hydrolysis and its high capacity to permeate intestinal cells.³⁴ One mechanism proposed to explain these effects involves L-type Ca^{2+} channels, independently of Ang II receptors.²⁸ In phase 1 clinical trials, Ang-(3–4) purified from sardine extracts administered orally depressed Ang II and aldosterone plasma levels (Figure 2(a)) and had clear antihypertensive effects in mildly hypertensive adults (Figure 2(b)).³² Increased Ang I plasma levels indicated that the inhibition of ACE *in vivo* also occurred.³² Interestingly, the plasma levels of Ang-(3–4) are markedly lower in hypertensive than in healthy individuals, levels negatively correlated with systolic pressure.³⁵

Basal renal levels of Ang-(3–4) are higher than in other tissues and plasma, and renal accumulation was also observed after a single oral administration (Figure 3).³⁶ This raises the question as to whether this renal accumulation of Ang-(3–4) was the result of uptake from the circulating plasma or arose from local synthesis, thus being a component of the renal local RAS? From combined use of fluorescent substrates for proteolytic enzymes, specific inhibitors, high performance chromatographic analyses and a family of synthetic peptides derived from Ang I and Ang II, it was found that successive conversion, i.e. of Ang II \rightarrow Ang-(1–7) \rightarrow Ang-(1–5) \rightarrow Ang-(1–4) \rightarrow Ang-(3–4), is the main route for the formation of Ang-(3–4) in basolateral membranes of proximal kidney tubule cells (Figure 4).²¹ This compartmentalisation of synthesis in basolateral membranes was indicative of a role in the important and varied transport processes – some mediated by ATPases – that carry ions across these membranes towards the renal interstitium. These processes are mostly linked to the homeostasis of body fluid compartments and the regulation of arterial blood pressure.^{37,38}

Ang-(3–4) and Ca^{2+} and Na^{+} transporters in kidney: interaction with Ang II receptors?

Plasma membrane Ca^{2+} -ATPase (PMCA) is considered to be the primary active transporter responsible for fine-tuning of Ca^{2+} extrusion from the cytosol.³⁹ In kidney proximal tubule cells, Ca^{2+} stimulates the Ang II-regulated reabsorption of fluid³⁸ and, therefore, small fluctuations of the cation within the cells are significant in homeostasis in body fluid compartments. Ang-(3–4), with a very high affinity, is a potent counteracting agent ($A_{1/2}$ in the femtomolar range) inhibiting PMCA exerted by Ang II in physiological concentrations in tissues (Figure 5(a)).⁴⁰ Mechanistically, Ang-(3–4) acts through a signaling pathway that starts with Ang II-type 2 receptors (AT_2R) and includes regulatory phosphorylation mediated by cAMP-activated protein kinase (PKA), which is upregulated by Ang-(3–4)-induced dissociation of

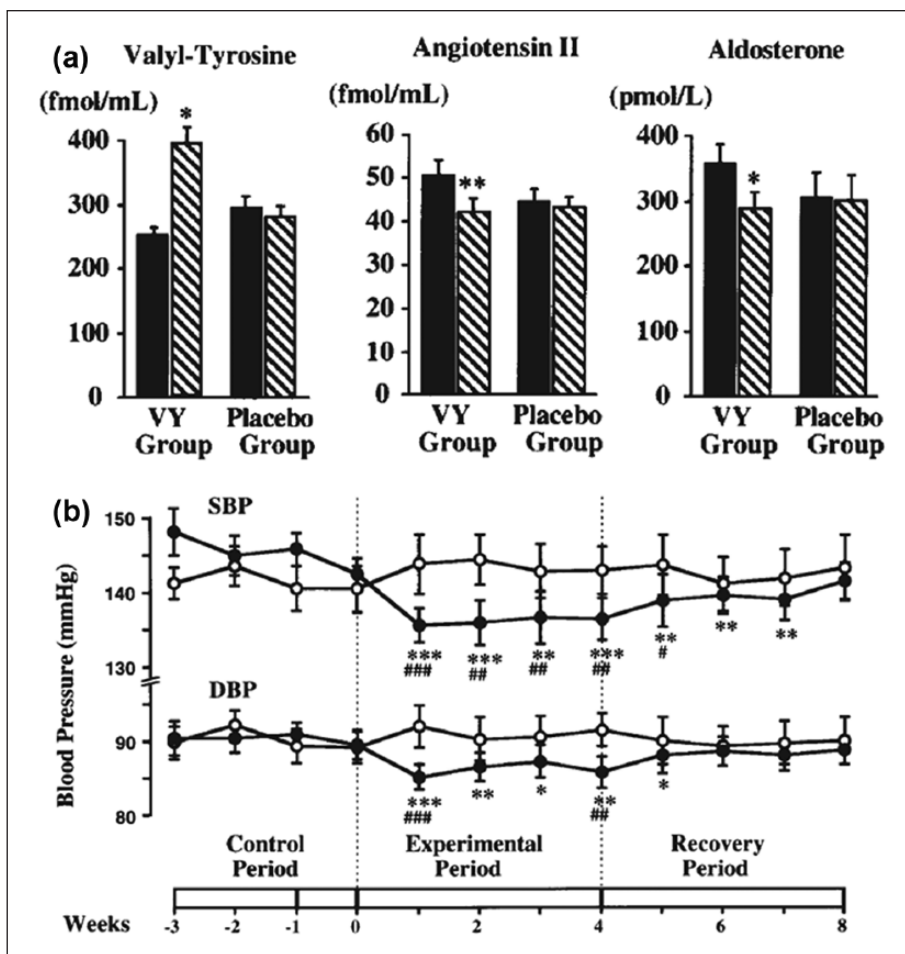

Figure 2. Oral treatment of mild hypertensive individuals with 3 mg angiotensin-(3–4) (Ang-(3–4)) (represented by VY), twice daily. (a) Plasma concentration of Ang-(3–4), angiotensin II (Ang II) and aldosterone before and after a 4-week experimental period. Increased levels of circulating Ang-(3–4) are seen in parallel with reduced plasma Ang II and aldosterone, supporting the idea that the dipeptide acts as a systemic angiotensin-converting enzyme inhibitor. (b) Systolic and diastolic blood pressure of hypertensive individuals were reduced during treatment with Ang-(3–4), which persisted for up to 7 weeks after the treatment was interrupted. Modified from Kawasaki et al.,³² with permission.

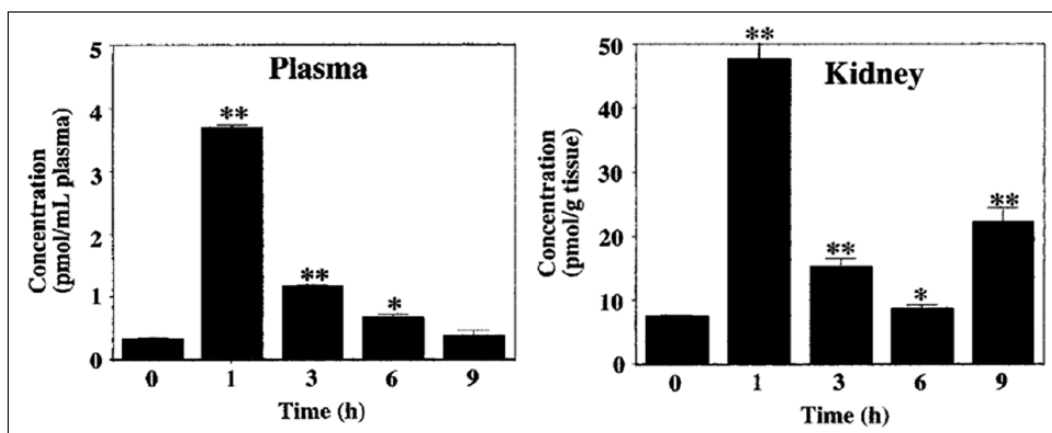

Figure 3. Plasma and kidney levels of angiotensin-(3–4) (Ang-(3–4)) after a single oral dose (10 mg/kg) in 18-week old spontaneously hypertensive rats. Although circulating concentrations of the dipeptide return to base levels 6 hours after administration, its level remains higher in the kidney, indicating the existence of a mechanism of tissue concentration or local production of Ang-(3–4). Modified from Matsui et al.,³⁶ with permission.

AT₁R/AT₂R heterodimers.^{40,41} Using a transfected renal cell line overexpressing AT₂R, Ang-(3–4) acts as an ‘allosteric enhancer’ and generates very high-affinity Ang II binding sites in this family of receptors (Figure 5(b)).⁴¹ This seems to be the first step by which Ang-(3–4) switches on an AT₂R-mediated signaling pathway that counteracts the inhibition of PMCA through the AT₁R-mediated pathway.

The antihypertensive effects of Ang-(3–4) in spontaneously hypertensive rats (SHRs)^{26,27} can also be explained

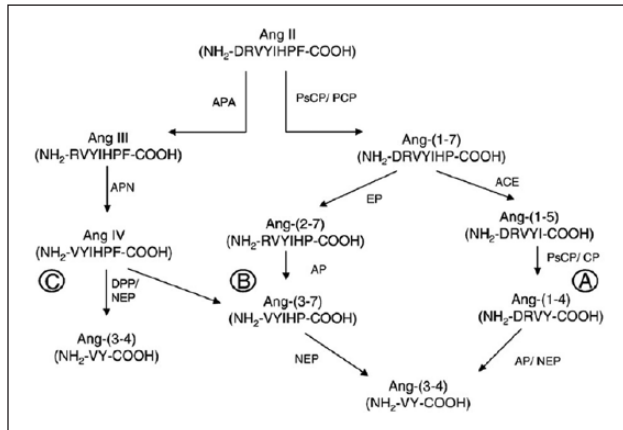

Figure 4. Enzymes and pathways responsible for angiotensin-(3–4) (Ang-(3–4)) formation in basolateral membranes from sheep kidney proximal tubule cells. Aminopeptidases and neprilysin are key enzymes required for at least one step of each pathway. AP: aminopeptidase; NEP: neprilysin; EP: endopeptidase; APA: aminopeptidase A; PsCP: Plummer’s sensitive carboxypeptidase; PCP: prolylcarboxypeptidase; ACE: angiotensin-converting enzyme; APN: aminopeptidase N; DPP: dipeptidylpeptidase. Reproduced from Axelband et al.,²¹ with permission.

by the specific targeting of Ang-(3–4) on Na⁺ transport in renal proximal tubules, in a local tissular environment pathologically modified due to hypertension. Ang-(3–4) strongly inhibits basolateral ouabain-resistant Na⁺-ATPase of SHRs, without any effect on the ouabain-sensitive (Na⁺+K⁺)ATPase or the ouabain-resistant Na⁺-ATPase of healthy rats.³³ Orally administered, it promotes a hypertonic natriuresis only in SHRs. Again, and probably as an indicator of the common mechanism exerted in the basolateral membranes: (a) the physiological effects of Ang-(3–4) requires dissociation of AT₁R/AT₂R heterodimers in normal rats (Figure 6(a)); and (b) inhibition of SHR Na⁺-ATPase is due to AT₂R upregulating PKA (Figure 6(b)).³³ The idea of a common cell signaling mechanism receives further support because the counteracting effects of Ang-(3–4) are exerted against AT₁R-mediated protein kinase C (PKC), one of the most important Ang II-stimulated modulators of transepithelial Na⁺ fluxes in the kidney.^{10,37,38,42,43} Although the actions of Ang-(3–4) in renal ion-transporting ATPases are significant when intrarenal Ang II levels are high, we should note the hierarchy in these effects: at very low (femtomolar) concentrations range, Ang-(3–4) reactivates the basolateral plasma membrane Ca²⁺-ATPase (Figure 5(a)), whereas nanomolar concentrations can inhibit Ang II-stimulated Na⁺-ATPase.³³ The resulting effect, requiring a continuous increase in Ang-(3–4) levels (formed from Ang II; Figure 4), would first lead *in vivo* to depressed intracellular Ca²⁺, diminished Ca²⁺-dependent PKC activity, recovery of lower basal Na⁺-pumping activity, and depressed active Na⁺ flux towards the peritubular space. Further inhibition of the Na⁺ pump itself – also by down-regulating PKC activity and upregulating PKA^{41–43} will occur as Ang-(3–4) increases in concentration.

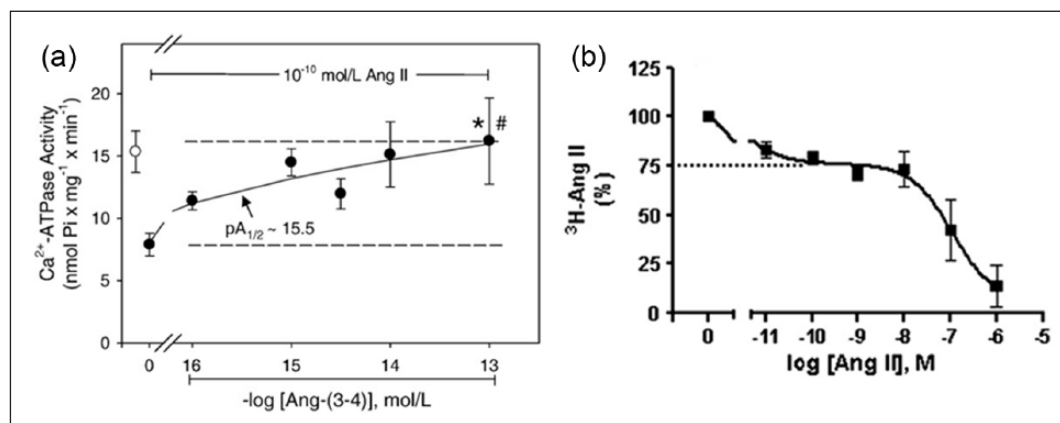

Figure 5. (a) Angiotensin-(3–4) (Ang-(3–4)) reactivates, with a very high affinity ($pA_{1/2} \sim 15.5$), the angiotensin II (Ang II)-inhibited basolateral plasma membrane Ca²⁺-ATPase. Ca²⁺ pump activity was assayed with 10⁻¹⁰ mol/L Ang II and increasing concentrations of Ang-(3–4). Modified from Axelband et al.,⁴⁰ with permission. (b) Ang-(3–4) creates a probable high affinity site for Ang II at Ang II-type 2 receptors at $\sim 10^{-12}$ mol/L, i.e. with an affinity ~ 5 orders of magnitude higher than in the absence of Ang-(3–4) (10⁻⁷ mol/L). The competition binding assay was carried out in HEK 293T cells overexpressing AT₂R in 10⁻¹⁰ mol/L Ang-(3–4). Modified from Axelband et al.,⁴¹ with permission.

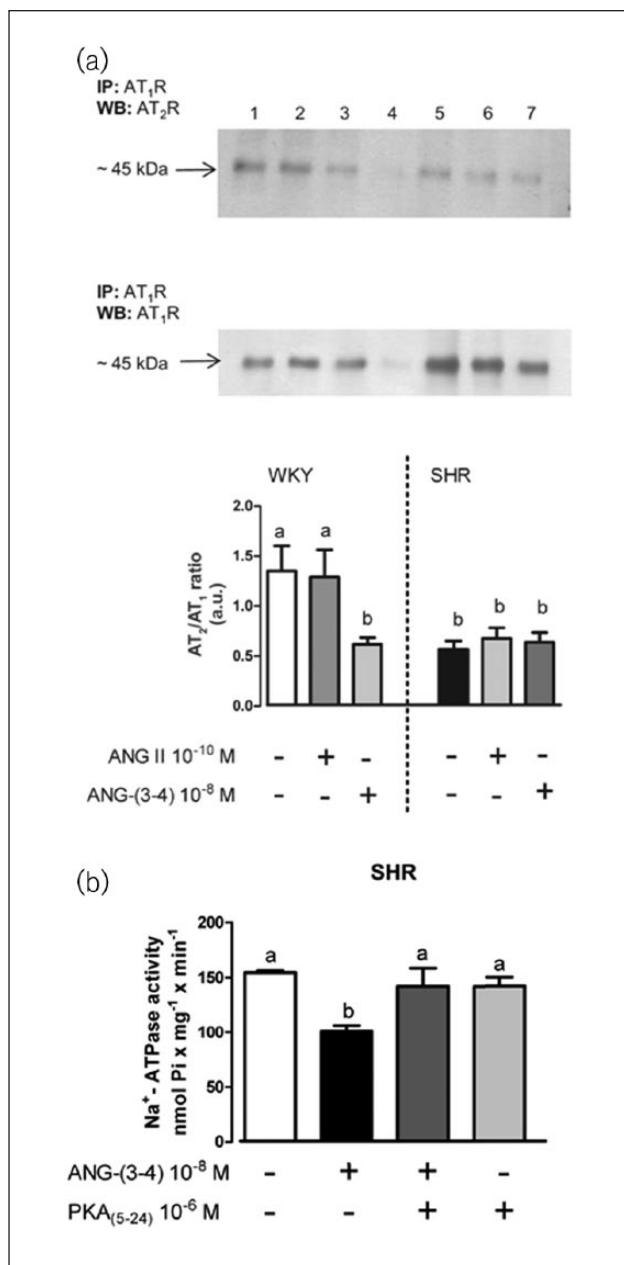

Figure 6. (a) Angiotensin-(3–4) (Ang-(3–4)) induces dissociation of Ang II-type 1 receptor (AT₁R)/Ang II-type 2 receptor (AT₂R) heterodimers in normotensive rats, but not in spontaneously hypertensive rats (SHRs). SHRs have a constitutively lower content of heterodimers. Immunoprecipitation assays were carried out using specific AT₁R antibody, followed by western blotting using specific AT₂R antibody. The specificity of the antibodies was confirmed by preadsorption of the antibodies onto the recombinant immunogenic peptide.⁴⁸ (b) Inhibition of SHR hyperactive Na⁺ pump by Ang-(3–4) is mediated by protein kinase A (PKA), downstream AT₂R activation. Na⁺-ATPase activity was assayed without any peptide, or in 10⁻⁸ mol/L Ang-(3–4) and 10⁻⁶ mol/L PKA inhibitor peptide PKA₍₅₋₂₄₎ in the combinations shown on the abscissae. Reproduced from Dias et al.,³³ with permission.

Even though interaction with AT₂R seems to play a pivotal role in Ang-(3–4) actions in renal tissue, little is known about its effects and related signaling mechanisms in other organs and tissues. As AT₂R are associated with a myriad of physiological actions in many different organs, and seem to be a common target of small peptides derived from natural proteins,⁴⁴ Ang-(3–4) actions might have much broader targets than initially thought. Thus it can be speculated that the AT₂R-mediated effects of Ang-(3–4) might include – beyond blood pressure control, natriuresis and vasorelaxation – neural and gastrointestinal actions, as demonstrated for other small peptides that bind to AT₂R.^{44–47} Furthermore, AT₂R-independent mechanisms might also mediate Ang-(3–4) actions in other tissues. The antiproliferative actions of this dipeptide in rat aorta were demonstrated to be independent of angiotensin receptors, but influenced by Ca²⁺-mediated pathways.²⁸ As the Ang-(3–4) influence on Ca²⁺ homeostasis seems to be a critical event in kidney cells,^{21,40,41} Ca²⁺ would be a signaling intermediate of the dipeptide actions in different tissues.

Conclusion

In summary, Ang-(3–4) can be considered one of the most potent counter-regulators of systemic and local RAS, with an important impact on body-fluid homeostasis through common mechanisms that target renal active transporters of Ca²⁺ and Na⁺, showing natriuretic and antihypertensive effects. As Ang-(3–4) permeates intestinal cells³⁴ and is effective when given orally,^{26,32,33} it is a potential antagonist of local and systemic Ang II effects for therapeutic purposes.

Acknowledgements

The excellent technical assistance of Glória Costa-Sarmiento is acknowledged. The authors are grateful to Dr Adriana K Carmona and Antonio Miranda (Federal University of São Paulo), Dr Claudio Costa-Neto (University of São Paulo) and Fernanda M Ferrão (State University of Rio de Janeiro) for helpful discussions and experimental collaboration. Correction of the English by BioMedES (UK) is gratefully acknowledged.

Declaration of conflicting interests

The author(s) declared no potential conflicts of interest with respect to the research, authorship, and/or publication of this article.

Funding

The author(s) disclosed receipt of the following financial support for the research, authorship, and/or publication of this article: Research in our laboratories receives financial support from the Brazilian National Research Council/CNPq, the Rio de Janeiro Research State Foundation/Faperj, the Ministry of

Health (Department of Science and Technology), the Brazilian Federal Agency for Support and Evaluation of Graduate Education/CAPES, and the Brazilian National Institutes of Science and Technology.

References

1. Tigerstedt R and Bergman PG. Niere und Kreislauf. *Skand Arch Physiol* 1898; 8: 223–271.
2. Houssay BA and Fasciolo JC. Secreción hipertensora del riñón isquemado. *Rev Soc Arg Biol* 1937; 13: 284–287.
3. Page IH. Vasopressor action of extracts of plasma of normal dogs and dogs with experimentally produced hypertension. *Proc Soc Exp Biol* 1937; 35: 112–116.
4. Braun-Menéndez E and Fasciolo JC. Acción vasoconstrictora e hipertensora de la sangre venosa del riñón en isquemia incompleta aguda. *Rev Soc Arg Biol* 1939; 15: 161–172.
5. Leloir LF, Muñoz JM, Braun-Menéndez E, et al. La secreción de la renina y la formación de hipertensina. *Rev Soc Arg Biol* 1940; 16: 75–80.
6. Fasciolo JC, Leloir LF, Muñoz JM, et al. On the Specificity of Renin. *Science* 1940; 92: 554–555.
7. Page IH, McSwain B, Knapp GM, et al. The origin of renin activator. *Amer J Physiol* 1941; 135: 214–222.
8. Shaltout HA, Westwood BM, Averill DB, et al. Angiotensin metabolism in renal proximal tubules, urine, and serum of sheep: evidence for ACE2-dependent processing of angiotensin II. *Am J Physiol Renal Physiol* 2007; 292: F82–F91.
9. Alenina N and Santos RAS. Angiotensin-(1–7) and Mas: a brief history. In: Unger T, Stecklings UM and Santos RAS (eds). *The Protective Arm of the Renin Angiotensin System (RAS), Functional Aspects and Therapeutic Implications*. 1st ed. Boston: Academic Press, 2015, pp. 155–159.
10. Paul M, Poyan Mehr A and Kreutz R. Physiology of local renin–angiotensin systems. *Physiol Rev* 2006; 86: 747–803.
11. Lyu L, Wang H, Li B, et al. A critical role of cardiac fibroblast-derived exosomes in activating renin angiotensin system in cardiomyocytes. *J Mol Cell Cardiol* 2015; 89: 268–279.
12. Vieitez P, Gómez O, Uceda ER, et al. Systemic and local effects of angiotensin II blockade in experimental diabetic nephropathy. *J Renin Angiotensin Aldosterone Syst* 2008; 9: 96–102.
13. Wright JW and Harding JW. The brain renin–angiotensin system: a diversity of functions and implications for CNS diseases. *Pflugers Arch* 2013; 465: 133–151.
14. Goto M, Hoxha N, Osman R, et al. Renin–angiotensin system (RAS) activation in congenital hepatic fibrosis in the PCK rat model of autosomal recessive polycystic kidney disease (ARPKD). *J Pediatr Gastroenterol Nutr* 2010; 50: 639–644.
15. Campbell DJ, Kladis A and Duncan AM. Nephrectomy, converting enzyme inhibition, and angiotensin peptides. *Hypertension* 1993; 22: 513–522.
16. De Mello WC and Frohlich ED. Clinical perspectives and fundamental aspects of local cardiovascular and renal renin–angiotensin systems. *Front Endocrinol (Lausanne)* 2014; 5: 16.
17. Zhuo JL, Imig JD, Hammond TG, et al. Ang II accumulation in rat renal endosomes during Ang II-induced hypertension: role of AT₁ receptor. *Hypertension* 2002; 39: 116–121.
18. Sun Y, Zhang J, Zhang JQ, et al. Renin expression at sites of repair in the infarcted rat heart. *J Mol Cell Cardiol* 2001; 33: 995–1003.
19. Lavoie JL, Cassell MD, Gross KW, et al. Localization of renin expressing cells in the brain, by use of a REN-eGFP transgenic model. *Physiol Genomics* 2004; 16: 240–246.
20. Shao W, Miyata K, Katsurada A, et al. Increased angiotensinogen expression, urinary angiotensinogen excretion, and tissue injury in nonclipped kidneys of two-kidney, one-clip hypertensive rats. *Am J Physiol Renal Physiol* 2016; 311: F278–F290.
21. Axelband F, Dias J, Miranda F, et al. A scrutiny of the biochemical pathways from Ang II to Ang-(3–4) in renal basolateral membranes. *Regul Pept* 2009; 158: 47–56.
22. Pang XF, Zhang LH, Bai F, et al. Attenuation of myocardial fibrosis with curcumin is mediated by modulating expression of angiotensin II AT₁/AT₂ receptors and ACE2 in rats. *Drug Des Devel Ther* 2015; 9: 6043–6054.
23. Navar LG and Nishiyama A. Why are angiotensin concentrations so high in the kidney? *Curr Opin Nephrol Hypertens* 2004; 13: 107–115.
24. Matsufuji H, Matsui T, Seki E, et al. Angiotensin I-converting enzyme inhibitory peptides in an alkaline protease hydrolyzate derived from sardine muscle. *Biosci Biotech Biochem* 1994; 58: 2244–2245.
25. Saito Y, Wanezaki K, Kawato A, et al. Structure and activity of angiotensin I converting enzyme inhibitory peptides from sake and sake lees. *Biosci Biotechnol Biochem* 1994; 58: 1767–1771.
26. Saito Y, Wanezaki K, Kawato A, et al. Antihypertensive effects of peptide in sake and its by-products on spontaneously hypertensive rats. *Biosci Biotechnol Biochem* 1994; 58: 812–816.
27. Matsufuji H, Matsui T, Ohshige S, et al. Antihypertensive effects of angiotensin fragments in SHR. *Biosci Biotech Biochem* 1995; 59: 1398–1401.
28. Matsui T, Ueno T, Tanaka M, et al. Antiproliferative action of an angiotensin I-converting enzyme inhibitory peptide, Val-Tyr, via an L-type Ca²⁺ channel inhibition in cultured vascular smooth muscle cells. *Hypertens Res* 2005; 28: 545–552.
29. Tanaka M, Matsui T, Ushida Y, et al. Vasodilating effect of di-peptides in thoracic aortas from spontaneously hypertensive rats. *Biosci Biotechnol Biochem* 2006; 70: 2292–2295.
30. Vercurysse L, Morel N, Van Camp J, et al. Antihypertensive mechanism of the dipeptide Val-Tyr in rat aorta. *Peptides* 2008; 29: 261–267.
31. Borawska J, Darewicz M, Pliszka M, et al. Antioxidant properties of salmon (*Salmo salar* L.) protein fraction hydrolysates revealed following their *ex vivo* digestion and *in vitro* hydrolysis. *J Sci Food Agric* 2016; 96: 2764–2772.
32. Kawasaki T, Seki E, Osajima K, et al. Antihypertensive effect of valyl-tyrosine, a short chain peptide derived from sardine muscle hydrolyzate, on mild hypertensive subjects. *J Hum Hypertens* 2000; 14: 519–523.
33. Dias J, Ferrão FM, Axelband F, et al. ANG-(3–4) inhibits renal Na⁺-ATPase in hypertensive rats through a mechanism that involves dissociation of ANG II receptors, heterodimers, and PKA. *Am J Physiol Renal Physiol* 2014; 306: F855–F863.

34. Pentzien AK and Meisel H. Transepithelial transport and stability in blood serum of angiotensin-I-converting enzyme inhibitory dipeptides. *Z Naturforsch* 2008; 63: 451–459.
35. Matsui T, Tamaya K, Matsumoto K, et al. Plasma concentrations of angiotensin metabolites in young male normotensive and mild hypertensive subjects. *Hypertens Res* 1999; 22: 273–277.
36. Matsui T, Imamura M, Oka H, et al. Tissue distribution of antihypertensive dipeptide, Val-Tyr, after its single oral administration to spontaneously hypertensive rats. *J Pept Sci* 2004; 10: 535–545.
37. Féraille E and Doucet A. Sodium-potassium-adenosinetriphosphatase-dependent sodium transport in the kidney: hormonal control. *Physiol Rev* 2001; 81: 345–418.
38. Du Z, Ferguson W and Wang T. Role of PKC and calcium in modulation of effects of angiotensin II on sodium transport in proximal tubule. *Am J Physiol Renal Physiol* 2003; 284: F688–F692.
39. Carafoli E. The calcium pumping ATPase of the plasma membrane. *Annu Rev Physiol* 1991; 53: 531–547.
40. Axelband F, Assunção-Miranda I, de Paula IR, et al. Ang-(3–4) suppresses inhibition of renal plasma membrane calcium pump by Ang II. *Regul Pept* 2009; 155: 81–90.
41. Axelband F, Dias J, Miranda F, et al. Angiotensin-(3–4) counteracts the angiotensin II inhibitory action on renal Ca^{2+} -ATPase through a cAMP/PKA pathway. *Regul Pept* 2012; 177: 27–34.
42. Silva PA, Muzi-Filho H, Pereira-Acácio A, et al. Altered signaling pathways linked to angiotensin II underpin the upregulation of renal Na^{+} -ATPase in chronically undernourished rats. *Biochim Biophys Acta* 2014; 1842: 2357–2366.
43. Vieira-Filho V, Cabral EV, Farias JS, et al. Renal molecular mechanisms underlying altered Na^{+} handling and genesis of hypertension during adulthood in prenatally undernourished rats. *Br J Nutr* 2014; 111: 1932–1944.
44. Yoshikawa M. Bioactive peptides derived from natural proteins with respect to diversity of their receptors and physiological effects. *Peptides* 2015; 72: 208–225.
45. Fändriks L. The angiotensin II type 2 receptor and the gastrointestinal tract. *J Renin Angiotensin Aldosterone Syst* 2010; 11: 43–48.
46. Umschweif G, Liraz-Zaltsman S, Shabashov D, et al. Angiotensin receptor type 2 activation induces neuroprotection and neurogenesis after traumatic brain injury. *Neurotherapeutics* 2014; 11: 665–678.
47. Zhang Y, Xiu M, Jiang J, et al. Novokinin inhibits gastric acid secretion and protects against alcohol-induced gastric injury in rats. *Alcohol* 2016; 56: 1–8.
48. Silva PA, Monnerat-Cahli G, Pereira-Acácio A, et al. Mechanisms involving Ang II and MAPK/ERK1/2 signaling pathways underlie cardiac and renal alterations during chronic undernutrition. *PLOS ONE* 2014; 9: e100410.