

Louisa Sadler: Multiple Controllers in Nominal Modification
Argumentum 15 (2019), 617–638
Debreceni Egyetemi Kiadó

Louisa Sadler

Multiple Controllers in Nominal Modification

Abstract

The standard view of predicate-argument agreement in LFG is based on co-specification, such that both the target and the controller specify values of f-structure features of the controller. The same co-specificational view is generally extended to cases of NP-internal concord. For both types of agreement, a feature-sharing approach, in which the agreement features are represented in the f-structures of both the target and the controller, is also possible. Recent work by Haug & Nikitina (2012, 2015) motivates a symmetrical feature-sharing analysis in a case of long-distance agreement in which an agreement target itself operates as a controller in a further agreement domain. We argue that a feature-sharing analysis is also motivated in the analysis of a particular class of adjectivally headed nominal modifiers in Arabic in which a single agreement target reflects the intrinsic properties of two different controllers.

Keywords: Modern Standard Arabic, Lexical Functional Grammar, agreement, multiple controllers

1 Introduction

The standard view of predicate-argument agreement in LFG is based on co-specification, such that both the target and the controller specify values of f-structure features of the controller: the most typical case is that of a finite verb, specifying values for the agreement attributes of the INDEX of its SUBJ. The same co-specificational view is generally extended to cases of NP-internal concord. For both types of agreement, of course, the choice between a co-specificational view and a feature-sharing view, in which the agreement features are represented in the f-structures of both the target and the controller, depends on the facts of the language in question. In recent work on the Latin dominant participle, Haug & Nikitina (2012, 2015) motivate a symmetrical feature-sharing account of a case of long-distance agreement in which an agreement target essentially operates as a controller in a further agreement domain. In this paper we hope to make a further contribution to the ongoing discussion of agreement phenomena within LFG. We discuss a case of NP-internal agreement in Modern Standard Arabic (MSA) in which a single agreement target reflects the intrinsic properties of two different controllers. We show how

-
- (3) a. al-lajnat-u l-mushrifat-u
 DEF-committee.FSG-NOM DEF-supervise.ACT.PTCP.FSG-NOM
 the supervisory committee Ryding (2005: 260)
- b. mihnat-un shāqqat-un
 profession.FSG-NOM.INDEF demand.ACT.PTCP.FSG-NOM.INDEF
 a demanding profession Ryding (2005: 260)
- (4) a. al-salmūn-u l-mudaxxan-u
 DEF-salmon.MSG-NOM DEF-smoke.PASS.PTCP.MSG-NOM
 smoked salmon Ryding (2005: 261)
- b. al-ʔraaḍī l-muḥtallat-u
 DEF-land.MPL DEF-occupy.PASS.PTCP.FSG-NOM
 the occupied lands Ryding (2005: 261)

Adjectival modifiers precede any PP or sentential complements of the head noun, and also precede any modifying relative clauses. They are positioned immediately after the head noun unless the noun is in an ‘annexation structure’ (construct phrase or *ʔidāfa*) with another NP. In this case, any adjectival modifiers follow the whole annexation or construct phrase. In this extremely common structure the second NP (in genitive case) may be related to the head noun by a large number of semantic relationships, including, but not limited to, those of possession, whole-part, measurement and purpose. The examples in (5) illustrate, and also show that when the second NP is pronominal, it is expressed synthetically as an affixal pronoun.² The f-structure analysis of this construction, and especially the question of the grammatical function of the second term (the *muḍāf ʔilay-hi* in Arabic grammatical terminology), raises many questions which we do not pursue in any detail here. From the point of view of c-structure, the annexation structure itself in analytic examples such as (5a,b) is a possible expansion of N' in (6).

- (5) a. tabīb-u ʔasnān-in jayyid-un
 dentist.MSG-NOM tooth.MPL-GEN.INDEF good.MSG-NOM.INDEF
 a good dentist Ryding (2005: 213)
- b. jawaaz-u l-safari l-masrūq-u
 permit.MSG-NOM DEF-travel.MSG-GEN DEF-steal.PASS.PTCP.MSG-NOM
 the stolen passport Ryding (2005: 213)
- c. ḥimār-u-hu
 donkey.MSG-NOM-3MSG.GEN
 his donkey Badawi et al. (2003: 132)

² In this structure, the definiteness value of the head noun is inherited from the second NP: the head noun itself is not inflected with either the definite article or *-n* (nunation), the marker of syntactic indefiniteness seen in examples such as (1a) and (3b) above.

(6) NP → N' AP*
 ↑ = ↓ ↓ ∈ (↑ ADJ)

Naturally enough, the (somewhat unexceptional) agreement behaviour of attributive adjectives can be accommodated very straightforwardly following standard assumptions. We can assume that the lexical entries of attributive adjectives place constraints directly on the agreement features of the head Noun, with (7) being relevant to the adjective in (1a). In combination with the relevant c-structure rules and lexical entry for *qiṣṣat-un* ‘story.FSG-NOM.INDEF’, this gives rise to the f-structure in (8). Wechsler & Zlatić (2003) and much subsequent work in LFG motivates the distinction between two sets of syntactic agreement features, INDEX and CONCORD. The distinction between these two sets of features was originally motivated in relation to ‘hybrid’ elements, which control different values of NUM and GEND features on different agreement targets. The features in the INDEX feature bundle (typically PERS, NUM and GEND) are more closely related to semantic features and tend to be implicated in more semantically-grounded agreement phenomena such as pronominal anaphora and predicate-argument agreement, while those in the CONCORD feature bundle (typically NUM, GEND and CASE) are more closely related to morphological inflectional classes and tend to be implicated in NP-internal agreement phenomena - in Arabic, DEF is an additional CONCORD feature. A comprehensive overview of work on INDEX and CONCORD in LFG can be found in Dalrymple et al (in press).

(7) *ṭawīl-at-un* A (↑ PRED) = ‘LONG’
 ((ADJ ∈ ↑) CONCORD) = %AGR
 (%AGR GEND) = FEM
 (%AGR NUM) = SG
 (%AGR DEF) = –
 (%AGR CASE) = NOM

(8)
$$\left[\begin{array}{l} \text{PRED} \quad \text{‘STORY’} \\ \text{INDEX} \quad \left[\begin{array}{ll} \text{NUM} & \text{SG} \\ \text{PERS} & 3 \\ \text{GEND} & \text{FEM} \end{array} \right] \\ \text{CONC} \quad \left[\begin{array}{ll} \text{NUM} & \text{SG} \\ \text{GEND} & \text{FEM} \\ \text{CASE} & \text{NOM} \\ \text{DEF} & \text{–} \end{array} \right] \\ \text{ADJ} \quad \{ \left[\text{PRED} \quad \text{‘LONG’} \right] \} \end{array} \right]$$

In a slightly different approach, we might model the agreement facts using feature sharing, as proposed by Haug & Nikitina (2012) for Latin participles (and see also Haug & Nikitina (2015)). In this approach both the f-structure of the noun and that of the adjective would contain the relevant agreement features and either the c-structure rule (by adding the appropriate annotation to the AP category) or the lexical entry for the attributive adjective would introduce feature sharing by means of functional control.

Replacing the local name %AGR in (7) with (\uparrow AGR) gives the f-description in (9), and would result in the f-structure in (10).³

- (9) *ṭawīl-at-un* A (\uparrow PRED) = ‘LONG’
 ((ADJ \in \uparrow) CONCORD) = (\uparrow AGR)
 (\uparrow AGR GEND) = FEM
 (\uparrow AGR NUM) = SG
 (\uparrow AGR DEF) = –
 (\uparrow AGR CASE) = NOM

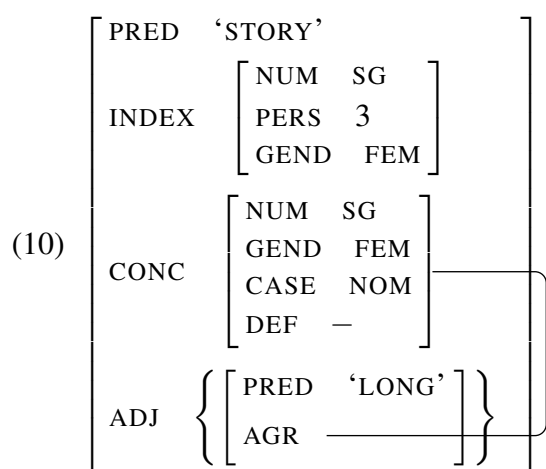

Examples such as (3) with simple N-modifying participles would receive the same analysis. The ACT.PTCP in (3a) would have the lexical description in (11) and the f-structure would be as in (12).

- (11) *l-mushrifat-u* A (\uparrow PRED) = ‘SUPERVISING’
 ((ADJ \in \uparrow) CONCORD) = (\uparrow AGR)
 (\uparrow AGR GEND) = FEM
 (\uparrow AGR NUM) = SG
 (\uparrow AGR DEF) = +
 (\uparrow AGR CASE) = NOM

³ Haug & Nikitina (2012) use the annotation (\uparrow AGR) = ((ADJ \in \uparrow) AGR), using a feature AGR on both controller and target to group the agreement features, but here we maintain the use of CONCORD for the inherent/intrinsic features.

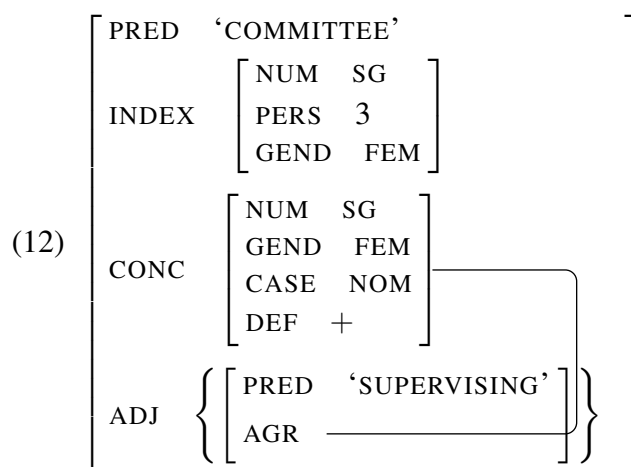

We see therefore that both the co-specificational approach and the feature sharing approach provide a straightforward account of agreement of attributive adjectival modifiers in MSA.

3 Predicative Adjective Agreement

Adjectives, nouns and prepositions can all serve as main clausal predicates in Arabic receiving a present tense interpretation by default. Adjectival predicates in such verbless sentences show predicate-argument (INDEX) agreement in NUM and GEND with their subject. In the absence of a copula they appear in the NOM, INDEF form. In the presence of the tense-carrying copula verb (e.g. in sentences with past or future time reference) they appear in the ACC, INDEF form).⁴ Notice that this alternation might itself be taken as evidence that these predicates have intrinsic AGR features, which are constructionally constrained in the case of the ‘null’/overt copula constructions, because the CASE and DEF features are not required to be identical to those of the subject itself.

- (13) a. al-waqt-u šatawiyy-un
 DEF-time.MSG-NOM wintry.MSG-NOM.INDEF
 The time is wintry. Badawi et al. (2003: 309)
- b. kāna l-jaww-u ḥārr-an
 be.PV.3MSG DEF-weather.MSG-NOM hot.MSG-ACC.INDEF
 The weather was hot. Badawi et al. (2003: 400)

The NUM and GEND features of the predicative adjective are controlled by (the INDEX features of) the SUBJ, an agreement relation which could also in principle be modelled in terms of co-specification (of the features of the SUBJ) or feature-sharing between the SUBJ and the AGR attribute on the adjectival head. Since there is no evidence (e.g. from independence of feature) to support the alternative, we will adopt the co-specificational view, excluding cases

⁴ We do not develop an analysis of copula clauses here.

of INDEX agreement from determining values of AGR on agreement targets. The lexical description for the predicative *šatawiyy-un*, given co-specification, is (14). (In what follows, we will indicate by means of a subscript on the category label whether the adjective is predicative or attributive. This is simply for greater clarity in presentation and does not constitute part of our theory of lexical categories.) The lexical description for the attributive *šatawiyy-un* ‘wintry.MSG-NOM.INDEF’ is shown in (15).

- (14) *šatawiyy-un* A_{pred} (↑ PRED) = ‘WINTRY< SUBJ>’
 (↑ SUBJ INDEX GEND) = MASC
 (↑ SUBJ INDEX NUM) = SG
 (↑ AGR DEF) = –
 (↑ AGR CASE) = NOM

- (15) *šatawiyy-un* A_{attr} (↑ PRED) = ‘WINTRY’
 ((ADJ ∈ ↑) CONCORD) = (↑ AGR)
 (↑ AGR GEND) = MASC
 (↑ AGR NUM) = SG
 (↑ AGR DEF) = –
 (↑ AGR CASE) = NOM

We can abbreviate entries such as these using templates which will allow us to capture some generalizations about linguistic information, such as the fact that CASE and DEF do not share the same distributional behaviour as NUM and GEND. Templates are named lexical descriptions, which simply contain the information which may be expressed in f-descriptions. Templates can be parameterised, that is, they can take arguments so that information can be fed into the template. For example, the templates in (16) have an argument X which is given a value in the call to the template (as shown in the lexical entries (17) and (18)), and which specifies the path to the f-structure for which the features (DEF and CASE for (16a) and GEND and NUM for (16b)) are defined. We assume the templates in (16) and corresponding other feature-value pairs (e.g. there will be a template ACCINDEF(X) defining CASE = ACC and DEF = – for the f-structure denoted by X, and a template FPL(X) defining GEND = FEM and NUM = PL for the f-structure denoted by X, and so on).

- (16) a. NOMINDEF(X) = (↑ X DEF) = –
 (↑ X CASE) = NOM
- b. MSG(X) = (↑ X GEND) = MASC
 (↑ X NUM) = SG

Revisiting the lexical entries in the light of these gives us the following for predicative and attributive uses respectively.

- (17) *šatawiyy-un* A_{pred} (↑ PRED) = ‘WINTRY< SUBJ>’
 @MSG(SUBJ INDEX)
 @NOMINDEF(AGR)

- (18) *šatawiyy-un* A_{attr} (\uparrow PRED) = ‘WINTRY’
 (\uparrow AGR) = ((ADJ \in \uparrow) CONCORD)
 @MSG(AGR)
 @NOMINDEF(AGR)

4 Semantically Linked Qualifiers

The focus of this paper is on an adjectivally-headed construction which differs in several respects from the simple attributive and predicative APs described in the previous sections. The Arabic term for this noun modifying construction is *naʕt sababī* ‘semantically linked qualifier’, capturing the idea that there is an obligatory resumptive pronoun within the AP which links the content of the modifier to the nominal head. (19) illustrates this construction. In boldface in (19) we have an AP attributive modifier which has a more complex internal structure than those discussed above. In particular, the head of the AP *l-mutaqaddim-i* ‘DEF-preceding.MSG-GEN’ has a NOM-marked dependent corresponding to its own arg1 (or external argument), which itself contains a resumptive pronominal argument (corresponding to its own arg2 or internal argument) referring back to the nominal head of the whole construction, namely *l-ğazāʕir-i* DEF-island.FPL-GEN. This pronominal affix is (glossed as) GEN because it is the dependent of the nominal (maʕdar) head *ḍikr-u* ‘mentioning.MSD.MSG-NOM’ in a (synthetic) annexation structure (see (5c) above), and **not** because its antecedent in this example is also GEN.

- (19) *li -l-ğazāʕir-i_i* **-l-mutaqaddim-i**
 to DEF-island.FPL-GEN DEF-preceding.MSG-GEN
ḍikr-u-hā_i
 mentioning.MSD.MSG-NOM-FSG.GEN
 to the aforementioned islands

Kremers (2003: 99)

Note in particular the agreement pattern in (19). As expected, the head of the AP agrees in CASE and DEF with the N which it modifies (the GEN case on the nominal head is governed by the preposition *li* ‘to’). However the NUM and GEND of the adjectival modifier (which is MSG) are determined in agreement with its own NOM-marked argument. As a result the adjectival head shows a mixed agreement pattern (responding to two different controllers). The affixal resumptive pronoun (referring back to the nominal head of the whole construction) is FSG because non-human plurals control deflected, FSG agreement.

While the adjectival modifier in (19) is headed by a PTCP form, the occurrence of this construction in MSA is not limited to participial modifiers.⁵ The PASS.PTCP form in (20) agrees in CASE and DEF with the N which it modifies, but is FSG in agreement with the NUM and GEND of its own (Nominative) argument *šidd-at-u* ‘strength-FSG-NOM’. In (21) the head of the modifying phrase is the adjective *šaʕb* ‘difficult’. This adjective is MSG in agreement with

⁵ This is an important point. Doron & Reintges (2006) discuss this construction as inherently participial in nature, but Kremers (2003) makes explicit the fact that it extends to non-participial adjectives. Although we concentrate only on MSA here, it is worth noting that we find examples corresponding to the non-participial cases in vernacular Arabics, which do not seem to permit the participial cases.

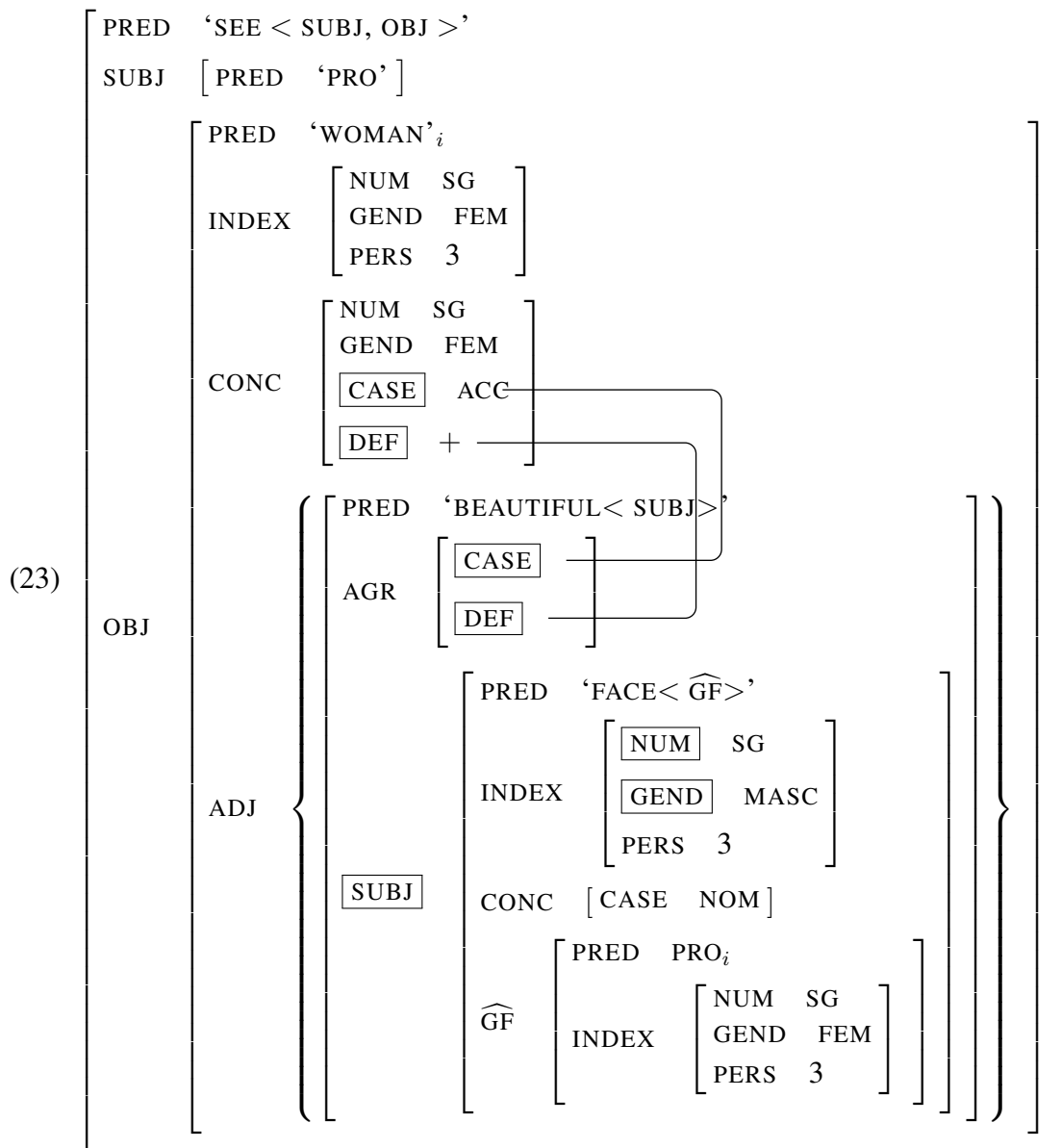

Note first that this is wholly consistent with the lexical descriptions for predicative adjectives discussed above. Following the standard view, we have suggested above that predicative adjectives co-specify the INDEX (NUM, GEND) features of their SUBJ. The examples in (13) also show that they have constructionally determined intrinsic values for CASE and DEF. The lexical description for the predicative adjective *ġamīl-an* 'beautiful.MSG-ACC.INDEF' shown in (24) defines the f-structure in (25).

- (24) *ġamīl-an* A_{pred} (\uparrow PRED) = 'BEAUTIFUL < SUBJ >'
 @MSG(SUBJ INDEX)
 @ACCINDEF(AGR)

$$(25) \left[\begin{array}{l} \text{PRED} \quad \text{'BEAUTIFUL< SUBJ>'} \\ \text{AGR} \quad \left[\begin{array}{l} \text{CASE} \quad \text{ACC} \\ \text{DEF} \quad - \end{array} \right] \\ \text{SUBJ} \quad \left[\begin{array}{l} \text{INDEX} \quad \left[\begin{array}{l} \text{NUM} \quad \text{SG} \\ \text{GEND} \quad \text{MASC} \end{array} \right] \end{array} \right] \end{array} \right]$$

In terms of agreement it would be necessary to ensure that the AGR features specified on the predicative adjective match those of the noun it modifies. Suppose for the moment that we alter the treatment of NP-internal concord so that it is constructionally rather than lexically specified. That is, we replace the c-structure rule (6), which introduces noun-modifying APs, by (26), in which the feature-sharing specification for attributive AP modifiers is expressed in the rule itself. In line with this, we would simplify the attributive entries, replacing (27) by (28).

$$(26) \text{ NP} \rightarrow \quad \text{N}' \quad \quad \quad (\text{AP}) \quad \quad \quad \dots\dots$$

$$\quad \quad \quad \uparrow = \downarrow \quad \quad \quad \downarrow \in (\uparrow \text{ ADJ})$$

$$\quad \quad \quad (\downarrow \text{ AGR}) = (\uparrow \text{ CONCORD})$$

$$(27) \text{ } \dot{t}\text{aw}\dot{i}l\text{-at-un} \quad A_{attr} \quad (\uparrow \text{ PRED}) = \text{'LONG'}$$

$$\quad \quad \quad ((\text{ ADJ} \in \uparrow) \text{ CONCORD}) = (\uparrow \text{ AGR})$$

$$\quad \quad \quad @\text{FSG}(\text{AGR})$$

$$\quad \quad \quad @\text{NOMINDEF}(\text{AGR})$$

$$(28) \text{ } \dot{t}\text{aw}\dot{i}l\text{-at-un} \quad A_{attr} \quad (\uparrow \text{ PRED}) = \text{'LONG'}$$

$$\quad \quad \quad @\text{FSG}(\text{AGR})$$

$$\quad \quad \quad @\text{NOMINDEF}(\text{AGR})$$

Taking into account the constraints associated with the c-structure rule in (26) and the lexical description of the predicative *ğamīl-an*, the (partial) f-structure for (22) would then be (29).

$$(29) \left[\begin{array}{l} \text{CONC} \quad \left[\begin{array}{l} \text{NUM} \quad \text{SG} \\ \text{GEND} \quad \text{FEM} \\ \text{CASE} \quad \text{ACC} \\ \text{DEF} \quad + \end{array} \right] \\ \text{ADJ} \quad \left\{ \begin{array}{l} \left[\begin{array}{l} \text{PRED} \quad \text{'BEAUTIFUL< SUBJ>'} \\ \text{AGR} \quad \left[\begin{array}{l} \text{NUM} \quad \text{SG} \\ \text{GEND} \quad \text{MASC} \\ \text{PERS} \quad 3 \end{array} \right] \end{array} \right\} \\ \left[\begin{array}{l} \text{PRED} \quad \text{'FACE< } \widehat{\text{GF}} \text{'>} \\ \text{INDEX} \quad \left[\begin{array}{l} \text{NUM} \quad \text{SG} \\ \text{GEND} \quad \text{MASC} \\ \text{PERS} \quad 3 \end{array} \right] \\ \dots\dots \end{array} \right] \end{array} \right]$$

Several issues arise with respect to an analysis based on the assumption that externally the (predicative) AP simply fills the normal attributive AP position. The adjectival head would be associated with AGR NUM and AGR GEND features which do not match those which it actually ‘spells out’ (which are the co-specified SUBJ INDEX NUM and SUBJ INDEX GEND features), though this may not in itself have serious consequences. However, the analysis also assumes a c-structure in which the SUBJ of the predicative AP appears *within* the AP, which is elsewhere unattested. In fact, the internal structure resembles that of a verbless predication, with an in-bound resumptive dependency, suggestive of an analysis as a type of non-finite relative clause (as noted above, working with a very different set of theoretical assumptions, Doron & Reintges (2006) discuss the participial instances of this construction as participial relatives). We might postulate an internal structure using a predicate-initial configurational subject-predicate construction as in (30) for examples such as (20) *maʿrūf-at-in šidd-at-u ḥarārat-i-hi* (in context: ‘famous for the strength of its heat’).

(30) S → XP NP
 ↑ = ↓ (↑ SUBJ) = ↓

(31)

maʿrūfatin
 know.PASS.PTCP-FSG-GEN.INDEF

In the rest of this paper we develop an analysis of these adjectivally headed semantically linked qualifiers as a non-finite relative structures, exploring how the LFG analysis of relative clauses with resumptives can be extended to accommodate this class of examples.

6 Relative Clauses

The basic treatment of restrictive relative clauses (RRCs) involves an unbounded dependency within an ADJ to a nominal head, as illustrated by the f-structure (32) for *man who Chris saw* (Dalrymple 2001: 415-421).

(32)

The various components of the analysis can be seen from the following rules for English (Dalrymple 2001: 402, 419). The CP rule introduces a TOPIC function which contains somewhere within it a relative pronoun (allowing for pied piping in English) and states that the TOPIC also corresponds to some within-clause grammatical function; the paths RELPATH and RTOPICPATH are given appropriate definitions. In the case of relative clauses which contain no relative pronoun (such as the English *man Chris saw*), a TOPIC PRED) = ‘PRO’ associated with the lack of c-structure constituent as sister of C’ ensures that syntactic completeness and coherence are satisfied.

- (33) $N' \longrightarrow$ N' CP^*
 $\uparrow = \downarrow$ $\downarrow \in (\uparrow \text{ ADJ})$
- (34) $CP \longrightarrow$ $\{ \text{RelP} \mid \epsilon \}$ C'
 $(\uparrow \text{ TOPIC}) = \downarrow$ $(\uparrow \text{ TOPIC PRED}) = \text{‘PRO’}$ $\uparrow = \downarrow$
 $(\uparrow \text{ TOPIC RELPATH}) = (\uparrow \text{ RELPRO})$ $(\uparrow \text{ TOPIC}) = (\uparrow \text{ RELPRO})$ **[rel]**
 $(\uparrow \text{ TOPIC}) = (\uparrow \text{ RTOPICPATH})$ $(\uparrow \text{ TOPIC}) = (\uparrow \text{ RTOPICPATH})$
 $(\uparrow \text{ RELPRO PRONTYPE}) =_c \text{REL}$

Semantic composition within the relative clause itself will produce a meaning of type $\langle e, t \rangle$. Continuing with the example from Dalrymple (2001), for *who Chris saw* this will be $\lambda X. \text{person}(X) \wedge \text{see}(\text{Chris}, X)$. The lexical meaning of *who* is simply $\lambda X. \text{person}(X)$; no lexical meaning associated with the TOPIC where there is no overt relative pronoun (i.e. when the ϵ disjunct is selected in the c-structure rule).

The meaning constructor **[rel]** takes care of the semantic composition of the relative clause as a modifier, integrating its semantics with that of the nominal head. In the case of *man who Chris saw* this is $\lambda X. \text{person}(X) \wedge \text{see}(\text{Chris}, X) \wedge \text{man}(X)$. This can be stated as in (35) (Dalrymple 2001: 417), Asudeh (2012: 176)).

(35) **Relative Modifier Resource (rel):**

$$\lambda P \lambda Q \lambda x. Q(x) \wedge P(x):$$

$$[(\uparrow \text{ TOPIC})_\sigma \multimap \uparrow_\sigma] \multimap [(((\text{ ADJ } \in \uparrow)_\sigma \text{ VAR}) \multimap ((\text{ ADJ } \in \uparrow)_\sigma \text{ RESTR})) \multimap$$

$$(((\text{ ADJ } \in \uparrow)_\sigma \text{ VAR}) \multimap ((\text{ ADJ } \in \uparrow)_\sigma \text{ RESTR}))]$$

Things are a little more complicated when the unbounded dependency involves a resumptive pronoun rather than a ‘gap’, a matter discussed extensively from an LFG point of view in Asudeh (2011, 2012). We can illustrate the approach in relation to the Irish data Asudeh discusses, which usefully combines the lack of an overt relative pronoun with the use of syntactic resumptives (Asudeh 2012: 181) from McCloskey (1979: 6)).

- (36) an scríbhneoir a molann na mic léinn é
 the writer aN praise the students him
 the writer who the students praise Irish

Firstly, the relation between the TOPIC (in the case of a relative clause) and the within-clause function involves a pronominal binding dependency, such as (37), which Asudeh (2012) associates with the complementising particle *aN* in Irish. This ensures that the discourse function is

correctly integrated and the Extended Coherence Condition is satisfied. Asudeh (2011, 2012) uses UDF as a cover term corresponding to the use of TOPIC and FOCUS for the discourse functions.

(37) **Binding Dependency:** Asudeh (2012: 181)
 $(\uparrow \text{UDF})_\sigma = ((\uparrow \text{GF}^+)_\sigma \text{ ANTECEDENT})^6$

Secondly, the pronominal constitutes an additional, unwanted resource in the semantics, which must be removed during the course of semantic composition. The standard approach to pronominal anaphora in this approach is variable-free — pronouns are functions on their antecedents. The pronoun consumes its antecedent and reintroduces a conjunction of the antecedent’s resource and its own resource (the glue side of this constructor is shown in (38)). This surplus resource is removed by a manager resource associated with the construction in which the resumptive use of the pronominal occurs (for example, in the case of Asudeh (2012)’s analysis of Irish, it is associated with (this use of) the complementiser *aN*). The manager resource (of which the glue side is shown in (39)) removes the pronoun (whose antecedent is a discourse function) and produces a function which itself consumes and reintroduces the resource of the antecedent.

(38) **Pronominal Resource:** Asudeh (2012: 84)
 $\lambda z.z \times z:$
 $(\uparrow_\sigma \text{ ANTECEDENT})_e \multimap ((\uparrow_\sigma \text{ ANTECEDENT})_e \otimes \uparrow_{\sigma e})$

(39) **Manager Resource (mr):** Asudeh (2012: 139)
 $[(\uparrow \text{UDF})_\sigma \multimap ((\uparrow \text{UDF})_\sigma \otimes (\text{GF}^+)_\sigma)] \multimap [(\uparrow \text{UDF})_\sigma \multimap (\uparrow \text{UDF})_\sigma]$

The easiest way to understand this is from these schematic representations of the lexically contributed resources Asudeh (2012: 128).

- | | |
|--|----------------------------------|
| 1. A | Lex. (antecedent) |
| 2. $A \multimap (A \otimes P)$ | Lex. (pronoun) |
| 3. $[A \multimap (A \otimes P)] \multimap (A \multimap A)$ | Lex. (manager resource) |

7 Analysis as Relative Modifiers

We now consider how an analysis of our adjectivally-headed construction can be developed on the basis of the approach to relative clauses with resumptive pronouns and without relative pronouns. Rather than (23) we suggest that the f-structure for an example such as (22) (repeated here as (40)) actually has much in common with a relative clause.

(40) raʔaytu -mraʔ-at-an **ğamīl-an** **wağh-u-hā**
 I.saw woman-FSG-ACC.INDEF beautiful.MSG-ACC.INDEF face.MSG-NOM-FSG.GEN
 I saw a woman with a beautiful face. Kremers (2003: 100)

⁶ Only pronominals have the semantic structure feature ANTECEDENT.

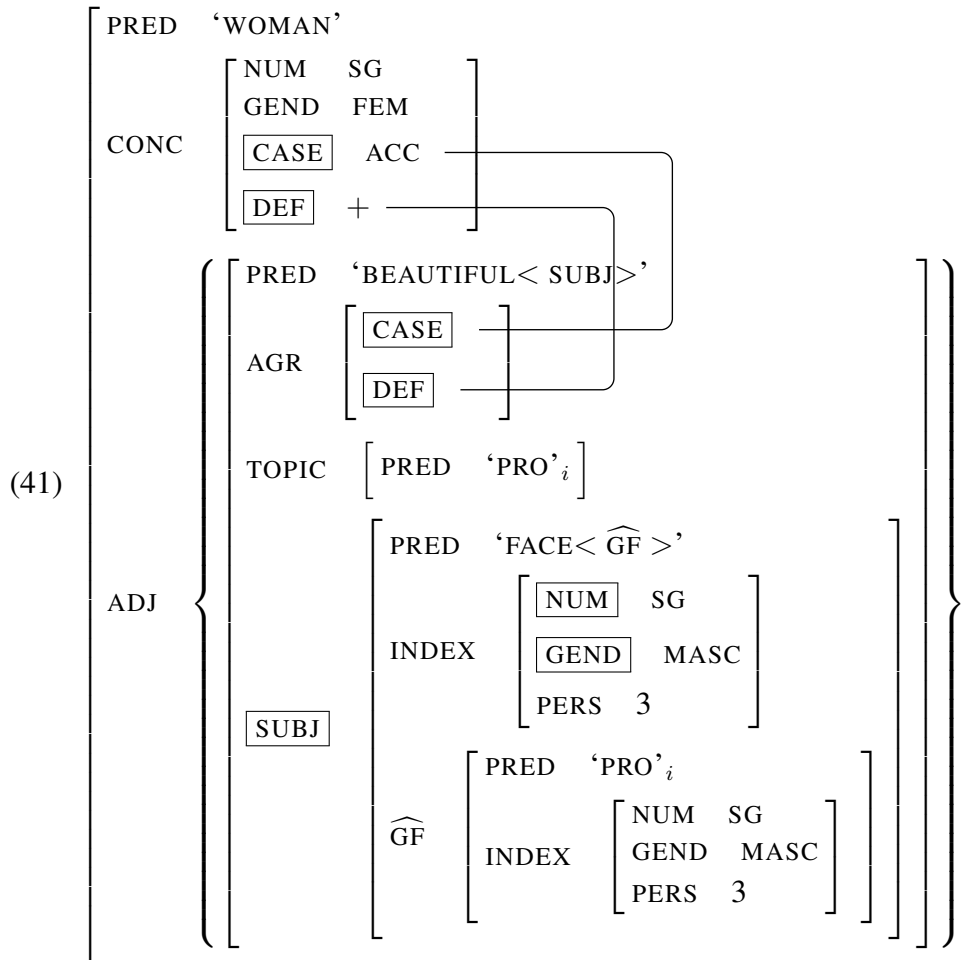

We propose the following c-structure rule (to be elaborated further) which introduces an S as the single daughter of a CP. The inside-out annotation ($ADJ \in \uparrow$) requires that the CP is a relative clause, and the rule also introduces an (unexpressed) pronominal TOPIC and a functional uncertainty equation providing a binder-resumptive relationship which will ensure satisfaction of the Extended Coherence Condition. This specifies that the TOPIC is the value of the ANTECEDENT attribute in the semantic structure associated with the (resumptive) pronominal.

$$\begin{aligned}
 (42) \quad CP &\longrightarrow S \\
 &\quad (ADJ \in \uparrow) \\
 &\quad (\uparrow \text{TOPIC PRED}) = \text{'PRO'} \\
 &\quad (\uparrow \text{TOPIC})_{\sigma} = ((\uparrow \text{GF}^+)_{\sigma} \text{ ANTECEDENT}) \\
 &\quad (\uparrow \text{TOPIC})_{\sigma} \neq ((\uparrow \text{SUBJ})_{\sigma} \text{ ANTECEDENT})
 \end{aligned}$$

The rule in (42) gives a maximally general statement of the anaphoric binding relationship, restricting neither the path nor the GF of the pronominal itself. In fact, the resumptive is not found in the highest subject position. Asudeh (2012: 203) suggests that a similar (but not identical) restriction⁷ on resumptives in Irish could be captured by an anti-binding condition

⁷ In the context of Asudeh (2012)'s analysis of Irish, (43) also rules out UDF-bound resumptives in embedded SUBJ positions.

This is the accurate formula such that finding the practical stages that have a chance of implementing it is cast upon the Palestinian leadership.

Doron & Reintges (2006: 44)

We have argued that the construction in (42) should be analysed as a sort of (non-finite) relative clause. It will therefore introduce the **rel** meaning constructor given in (35) above, which takes the semantics of the relative clause and turns it into a modifier, a function of type $\langle\langle e, t \rangle\langle e, t \rangle\rangle$, which will consume the semantic contribution of the nominal head and produce a modified semantics. It must also introduce a manager resource to remove the surplus pronominal resource contributed by the resumptive pronominal, that is a version of (39) (with the attribute name **TOPIC** substituted for the attribute name **UDF**). (47) extends and replaces (42).

$$\begin{array}{l}
 (47) \text{ CP} \longrightarrow \text{S} \\
 \quad (\text{ADJ} \in \uparrow) \\
 \quad (\uparrow \text{TOPIC PRED}) = \text{'PRO'} \\
 \quad (\uparrow \text{TOPIC})_{\sigma} = ((\uparrow \text{GF}^+)_{\sigma} \text{ ANTECEDENT}) \\
 \quad (\uparrow \text{TOPIC})_{\sigma} \neq ((\uparrow \text{SUBJ})_{\sigma} \text{ ANTECEDENT}) \\
 \quad \quad \quad \mathbf{[REL]} \\
 \quad \quad \quad \mathbf{[MR]}
 \end{array}$$

There is one more issue to consider before working through an example, which is that of the agreement we see between the resumptive pronoun and the ultimate antecedent, namely the nominal head which the relative clause modifies. This can be enforced syntactically by adding explicit agreement constraints to the c-structure rule, giving (48).

$$\begin{array}{l}
 (48) \text{ CP} \longrightarrow \text{S} \\
 \quad (\text{ADJ} \in \uparrow) \\
 \quad (\uparrow \text{TOPIC PRED}) = \text{'PRO'} \\
 \quad \quad \% \text{RPN} = (\text{GF}^+) \\
 \quad (\uparrow \text{TOPIC})_{\sigma} = ((\% \text{RPN})_{\sigma} \text{ ANTECEDENT}) \\
 \quad (\uparrow \text{TOPIC})_{\sigma} \neq ((\uparrow \text{SUBJ})_{\sigma} \text{ ANTECEDENT}) \\
 \quad ((\text{ADJ} \in \uparrow) \text{ INDEX}) = (\% \text{RPN INDEX}) \\
 \quad \quad \quad \mathbf{[REL]} \\
 \quad \quad \quad \mathbf{[MR]}
 \end{array}$$

In (48) a local name $\% \text{RPN}$ picks out the f-structure of the resumptive pronoun and the equation $((\text{ADJ} \in \uparrow) \text{ INDEX}) = (\% \text{RPN INDEX})$ states that it shares its **INDEX** with the nominal head. Alternatively, we might consider that since the **TOPIC** serves as the semantic **ANTECEDENT** of the resumptive pronoun, it is coherent to expect that agreement between these elements based on normal assumptions about this semantic relationship, which would have the consequence that we would only need to specify syntactic agreement between the **TOPIC** and the nominal head itself, because the relation between these is not one of semantic antecedence (for discussion of this point in relation to Irish, see Asudeh (2012: 206)), giving us (49).

- (53) *balad-in* N (\uparrow PRED) = ‘COUNTRY’
 @MSG(INDEX)
 (\uparrow INDEX PERS) = 3
 @GENINDEF(CONCORD)
- (54) *šidd-at-u* N (\uparrow PRED) = ‘STRENGTH< \widehat{GF} >’
 @FSG(INDEX)
 (\uparrow CONCORD CASE) = NOM
 ($\uparrow \widehat{GF}$ CONCORD CASE) = GEN
- (55) *ħarārat-i-hi* (\uparrow PRED) = ‘HEAT< \widehat{GF} >’
 @FSG(INDEX)
 @GENDEF(CONCORD)
 ($\uparrow \widehat{GF}$ PRED) = ‘PRO’
 ($\uparrow \widehat{GF}$ INDEX PERS) = 3
 @MSG(\widehat{GF} INDEX)
 @GENDEF(\widehat{GF} CONCORD)

The c-structure associated with this example is shown in (56).

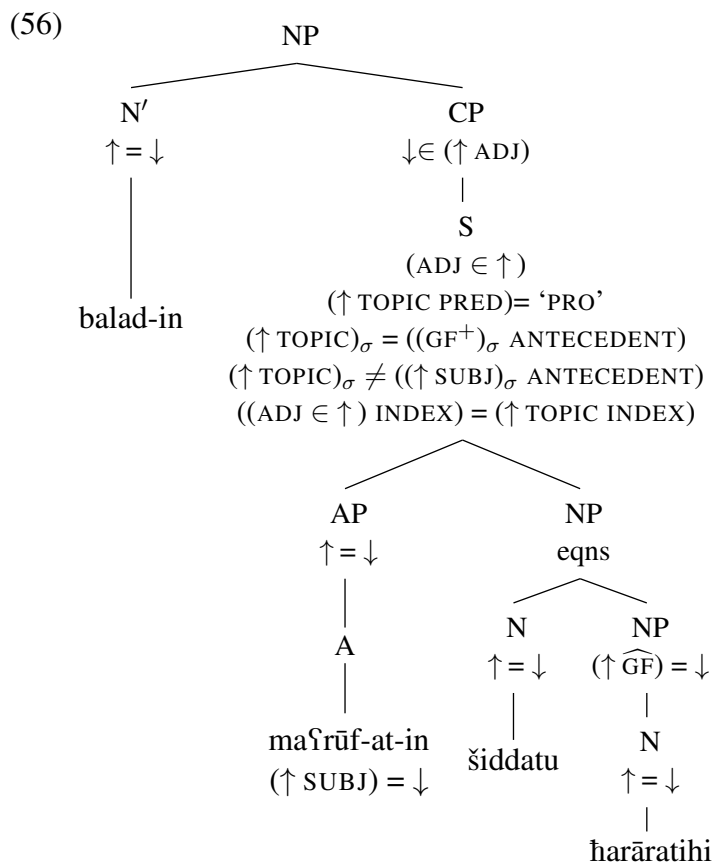

DEF and CONCORD CASE features of the nominal head *balad-in*. These means that as things stand, forms differing in CASE or DEF (such as *maḡrūf-at-an* (ACC.INDEF) and *maḡrūf-at-un* (NOM.INDEF)) are incorrectly predicted as grammatical here. This is fixed by amending (51) to (58).

$$\begin{array}{lcl}
 (58) \text{ NP} \longrightarrow & \text{N}' & \text{AP*} \qquad \qquad \text{CP*} \\
 & \uparrow = \downarrow & \downarrow \in (\uparrow \text{ ADJ}) \qquad \downarrow \in (\uparrow \text{ ADJ}) \\
 & & (\downarrow \text{ AGR}) = (\uparrow \text{ CONC}) \qquad (\downarrow \text{ AGR CASE}) = (\uparrow \text{ CONC CASE}) \\
 & & \qquad \qquad \qquad (\downarrow \text{ AGR DEF}) = (\uparrow \text{ CONC DEF})
 \end{array}$$

The annotations $(\downarrow \text{ AGR CASE}) = (\uparrow \text{ CONC CASE})$ and $(\downarrow \text{ AGR DEF}) = (\uparrow \text{ CONC DEF})$ on the CP ensure that the CASE and DEF features of the CP match those of the head Noun. These features will only be realized when the head of the construction (or one of the co-heads) is able to give them morphological expression, as it is in the case of an adjectivally headed non-finite relative clause. An interesting side-effect of this agreement constraint on the CP is that it might provide some account of the agreement which is seen in finite relative clauses in MSA. An overt relativising complementiser occurs *only* in relative clauses which modify definite nominal heads, a phenomenon which might be interpreted as some form of DEF agreement. This relativising element also shows overt agreement in CASE with the definite nominal head when it is DUAL in number.

9 Conclusion

In this paper we have discussed an adjectival construction in MSA in which a single agreement target (the adjective) agrees with two distinct controllers. We have argued that the construction should be viewed as a sort of non-finite relative clause headed by a predicative adjective, with a resumptive dependency relating the relativised position to the head noun. The adjective shows INDEX agreement with its SUBJ, modelled in terms of co-specification. However as (the head of) a nominal modifier, it also agrees in CASE and DEF which the noun which it modifies. We propose that this agreement process is modelled in terms of (constructionally induced) feature sharing between AGR features of the adjective and CONCORD features of the noun which it modifies.

References

- Asudeh, A. (2011): Towards a unified theory of resumption. In: Rouveret, A. (ed.): *Resumptive Pronouns at the interfaces*. Amsterdam: John Benjamins.
- Asudeh, A. (2012): *The logic of pronominal resumption*. Oxford: Oxford University Press.
- Badawi, E., Carter, M., & Gully, A. (2003): *Modern Written Arabic: A Comprehensive Grammar*. London: Routledge.
- Dalrymple, M. (2001): *Lexical Functional Grammar*. San Diego, CA.: Academic Press.
- Dalrymple, M., Lowe, J., & Mycock, L. (in press): *The Oxford Reference Guide to Lexical Functional Grammar*. Oxford: Oxford University Press.

- Doron, E. & Reintges, C. H. (2006): On the Syntax of Participial Modifiers. Ms, Hebrew University.
- Falk, Y. (2006): *Subjects and Universal Grammar: An Explanatory Theory*. Cambridge: Cambridge University Press.
- Haug, D. & Nikitina, T. (2015): Feature sharing in agreement. *Natural Language and Linguistic Theory*, 34(3), 865–910.
- Haug, D. T. T. & Nikitina, T. (2012): The Many Cases of Non-Finite Subjects: The Challenge of "Dominant" Participles. In: Butt, M. & King, T. H. (eds.): *Proceedings of the LFG12 Conference*, Stanford, CA. 292–311. CSLI Publications: <http://www-csli.stanford.edu/publications>.
- Kremers, J. (2003): *The Arabic noun phrase: a Minimalist approach*. Ph.D. thesis. University of Utrecht, Utrecht, The Netherlands.
- McCloskey, J. (1979): *Transformational Syntax and Model Theoretic Semantics: A Case Study in Modern Irish*. Dordrecht: D. Reidel.
- Ryding, K. (2005): *A Reference Grammar of Modern Standard Arabic*. Cambridge: Cambridge University Press.
- Wechsler, S. & Zlatić, L. (2003): *The Many Faces of Agreement*. Stanford, CA.: CSLI Publications.

Louisa Sadler
Department of Language and Linguistics,
University of Essex,
louisa@essex.ac.uk