

Department of Public Health and Finnish Institute for Molecular Medicine,
University of Helsinki, Finland

HERITABILITY OF TYPE 2 DIABETES AND RELATED TRAITS

Mikko Lehtovirta

ACADEMIC DISSERTATION

To be presented, with the permission of the Faculty of Medicine
at the University of Helsinki, for public examination in the Biomedicum 1 lecture hall 1,
Helsinki on January 24th 2014, at 12 noon.

Helsinki 2014

Publications of Public Health M220:2014

Supervisors

Professor Jaakko Kaprio
Department of Public Health
Hjelt-institute, University of Helsinki
Finnish Institute of Molecular Medicine (FIMM), University of Helsinki
National Institute for Health and Welfare (THL), Helsinki

Professor Leif Groop
Finnish Academy FiDiPro-professor
Finnish Institute of Molecular Medicine (FiMM), University of Helsinki
Department of Clinical Science Malmö, Diabetes & Endocrinology,
Lund University

Reviewed by

Docent Leo Niskanen, MD, PhD
University of Eastern Finland, Kuopio, Finland

Associate Professor Sofia Carlsson, PhD
Karolinska Institute, Stockholm, Sweden

Opponent

Docent Heikki Koistinen, MD, PhD
Department of Medicine, Division of Endocrinology
Helsinki University Central Hospital

ISSN 0355-7979
ISBN 978-952-10-6605-4 (paperback)
ISBN 978-952-10-9654-9 (PDF) ethesis.helsinki.fi

Unigrafia
Helsinki 2014

*I dedicate this work to my father, medical counsellor
Erkki Lehtovirta, MD, PhD, who is an exceptional colleague.
What more, he is a monozygotic twin, has participated in
the Finnish Twin Cohort Study and wrote his doctoral thesis
about obesity and glucose tolerance.*

TABLE OF CONTENTS

1. LIST OF ORIGINAL PUBLICATIONS.....	5
1.1 PUBLICATIONS NOT INCLUDED IN THE DOCTORAL THESIS	6
2. ABBREVIATIONS	8
3. LIST OF TABLES.....	12
4. LIST OF FIGURES	13
5. LIST OF EQUATIONS.....	14
6. ABSTRACT	17
7. INTRODUCTION	21
8. REVIEW OF THE LITERATURE	25
8.1 TYPE 2 DIABETES MELLITUS AND RELATED METABOLIC DISTURBANCES.....	25
8.1.1 OBESITY.....	25
Definition and diagnosis of obesity	25
Assessment of obesity.....	25
Genetics of obesity.....	27
8.1.2. TYPE 2 DIABETES MELLITUS	28
Definition and diagnosis of type 2 diabetes	28
Epidemiology of type 2 diabetes	29
Genetics of type 2 diabetes	29
8.1.3 INSULIN SECRETION	30
Physiology of insulin secretion.....	31
Genetics of insulin secretion	32
Assessment of insulin secretion	32
Fasting values and indices.....	33
Non-steady-state methods	34

	Steady-state methods: hyperglycaemic clamp.....	37
	Minimal model and approaches to insulin secretion using C-peptide kinetics	37
	Measurement of pulsatile insulin secretion.....	42
8.1.4	INSULIN ACTION	43
	Insulin sensitivity and insulin resistance.....	44
	History of insulin resistance.....	44
	Definition of insulin resistance	45
	Genetics of insulin resistance.....	46
	Assessment of insulin sensitivity or insulin resistance	47
	Fasting values and indices.....	48
	Non-steady-state methods	49
	Steady-state methods	55
	Limb balance techniques.....	57
	Combined methods.....	58
8.1.5	REPRODUCIBILITY OF ASSESSMENT METHODS	59
8.2	METHODOLOGY FOR THE STUDY OF VARIABILITY AMONG INDIVIDUALS	60
8.2.1	HISTORY OF QUANTITATIVE GENETICS	60
8.2.2	TWIN STUDIES	62
8.2.3	HERITABILITY.....	63
	Definition of the statistics of similarity.....	64
	Genotypes and population frequencies.....	65
	Decomposition of variances	66
	Bivariate model.....	67
	Heritability.....	69
	Intraclass correlations and concordances.....	69
8.2.4	STATISTICAL METHODS.....	70
	Structural equation modelling and path analysis.....	70

8.3 GENETICS OF COMPLEX DISORDERS	72
9. AIMS OF THE STUDY	76
10. MATERIALS AND METHODS	77
10.1 STUDY SUBJECTS.....	77
10.1.1 THE FINNISH TWIN COHORT STUDY	77
10.1.2 THE BOTNIA STUDY	77
10.1.3 DATA COMPILATION	78
Studies I to III.....	78
Study IV	78
Study V.....	79
10.2 METHODS.....	80
10.2.1 ANTHROPOMETRIC, BODY COMPOSITION AND BLOOD PRESSURE MEASUREMENTS.....	80
10.2.2 ASSESSMENT OF INSULIN SECRETION AND GLUCOSE METABOLISM.....	80
OGTT: studies II, III and V	80
IVGTT and clamp tests	81
IVGTT: studies I and II	81
Clamp tests: studies I and II.....	81
Botnia clamp.....	81
10.2.3 LABORATORY ASSAYS.....	82
10.2.4 CALCULATIONS.....	82
Beta cell function	82
Insulin sensitivity	83
10.2.5 STATISTICAL METHODS.....	83
Twin correlations and variance components in studies I to IV.....	84
Heritability of type 2 diabetes and quantitative traits in the Botnia Study, study V	85
11. RESULTS.....	87

11.1	CLINICAL CHARACTERISTICS.....	87
11.2	PHENOTYPIC CORRELATIONS.....	89
11.3	BMI AND THE RISK OF DEVELOPING TYPE 2 DIABETES MELLITUS (STUDY IV).....	89
11.4	TWIN CORRELATIONS	89
11.5	HERITABILITY OF TYPE 2 DIABETES AND ASSOCIATED TRAITS	91
11.5.1	DIRECT ESTIMATES OF HERITABILITY	91
11.5.2	INDIRECT ESTIMATES OF HERITABILITY	92
11.5.3	BIVARIATE ANALYSIS	93
12.	DISCUSSION.....	95
13.	SUMMARY AND CONCLUSIONS.....	99
14.	ACKNOWLEDGEMENTS	101
15.	REFERENCES	105
16.	ORIGINAL PUBLICATIONS	133

1. LIST OF ORIGINAL PUBLICATIONS

This thesis is based upon already published research (Table 1).

Table 1. Original publications.

Study	Paper
I	Lehtovirta M, Kaprio J, Forsblom C, Eriksson J, Tuomilehto J, Groop L. Insulin secretion and insulin sensitivity in monozygotic and dizygotic twins. <i>Diabetologia</i> 43:285–293, 2000.
II	Lehtovirta M, Kaprio J, Groop L, Trombetta M, Bonadonna RC. Heritability of model-derived parameters of beta cell secretion during intravenous and oral glucose tolerance tests: a study of twins. <i>Diabetologia</i> 48:1604–1613, 2005.
III	Katoh S, Lehtovirta M, Kaprio J, Harjutsalo V, Koskenvuo M, Eriksson J, Tajima N, Tuomilehto J. Genetic and environmental effects on fasting and postchallenge plasma glucose and serum insulin values in Finnish twins. <i>Journal of Clinical Endocrinology & Metabolism</i> 90:2642–2647, 2005.
IV	Lehtovirta M, Pietiläinen KH, Levälähti E, Heikkilä K, Groop L, Silventoinen K, Koskenvuo M, Kaprio J. Evidence that BMI and type 2 diabetes share only a minor fraction of genetic variance A follow-up study of 23585 monozygotic and dizygotic twins from the Finnish Twin Cohort Study. <i>Diabetologia</i> 53:1314–1321, 2010. doi 10.1007/s00125-010-1746-4
V	Almgren P, Lehtovirta M, Isomaa B, Sarelin L, Taskinen MR, Lyssenko V, Tuomi T, Groop L for the Botnia Study Group. Heritability and familiarity of type 2 diabetes and related quantitative traits in the Botnia Study. <i>Diabetologia</i> . 54:2811–2819, 2011. doi 10.1007/s00125-011-2267-5

Data and other material from the original publications are reproduced with permission of the copyright holders.

1.1 PUBLICATIONS NOT INCLUDED IN THE DOCTORAL THESIS

- Harrela M, Koistinen H, Kaprio J, Lehtovirta M, Tuomilehto J, Eriksson J, Toivanen L, Koskenvuo M, Leinonen P, Koistinen R, Seppälä M. Genetic and environmental components of interindividual variation in circulating levels of IGF-I, IGF-II, IGFBP-1 and IGFBP-3. *J Clin Invest* Vol 98: 2612–2615, 1996.
- Groop L, Forsblom C, Lehtovirta M, Tuomi T, Karanko S, Nissén M, Ehrnström BO, Forsén B, Snickars B and Taskinen MR. Metabolic consequences of a family history of NIDDM. (The Botnia Study). *Diabetes*. Vol 45: 1585–1593, 1996.
- Ferrannini E, Andrea Natali, Brunella Capaldo, Mikko Lehtovirta, Stefan Jacob, Hannele Yki-Järvinen, for the European Group for the Study of Insulin Resistance (EGIR). Insulin Resistance, Hyperinsulinemia, and Blood Pressure: Role of Age and Obesity. *Hypertension*. Vol 30, No 5, November, 1144–1149, 1997.
- Forsblom CM, Kanninen T, Lehtovirta M, Kaprio J, Saloranta C, Groop LC. Heritability of albumin excretion rate in families of patients with Type II diabetes. *Diabetologia*. Vol 42 (11): 1359–1366, 1999.
- Kaprio J, Eriksson J, Lehtovirta M, Tuomilehto J, Koskenvuo M: Heritability of leptin levels, and shared genetic influences on BMI and leptin. *Int J Obes*. Vol 25 (1): 132–137, 2001.
- Parker A, Meyer J, Lewitzky S, Rennich JS, Chan G, Thomas JD, Orho-Melander M, Lehtovirta M, Forsblom C, Hyrkkö A, Carlsson M, Lindgren C, Groop LC: A Gene Conferring Susceptibility to Type 2 Diabetes in Conjunction With Obesity Is Located on Chromosome 18p11. *Diabetes*. Vol 50: 675–680, 2001.
- Cretti A, Lehtovirta M, Bonora E, Brunato B, Zenti MG, Tosi F, Caputo M, Caruso B, Groop LC, Muggeo M, Bonadonna RC: Assessment of β -cell function during the oral glucose tolerance test by a minimal model of insulin secretion. *European J Clin Invest*. Vol 31 (5), 405–416, 2001.
- Lehtovirta M, Forsén B, Gullström M, Häggblom M, Eriksson JG, Taskinen MR, Groop L: Metabolic effects of metformin in patients with impaired glucose tolerance. A placebo-controlled intervention within the Botnia Study. *Diabetic Medicine*. Vol 18 (7), 578–583, 2001.
- Vaag A, Lehtovirta M, Thyse-Rönn P, Groop L: Metabolic impact of a family history of Type 2 diabetes. Results from a European multicentre study (EGIR). *Diabetic Medicine*. Vol 18 (7), 533–540, 2001.

Eriksson JG, Lehtovirta M, Ehrnström B, Salmela S, Groop L. Long-term beneficial effects of glipizide treatment on glucose tolerance in subjects with impaired glucose tolerance. *Journal of Internal Medicine*. 259 (6): 553–560, 2006.

Waller K, Kaprio J, Lehtovirta M, Silventoinen K, Koskenvuo M, Kujala UM. Leisure-time physical activity and the prevention of type 2 diabetes during a 28-year follow-up in twins. *Diabetologia*. 53(12): 2531–2537, 2010. doi 10.1007/s00125-010-1875-9

2. ABBREVIATIONS

A, D, C, E	latent variables representing additive and dominant genetic as well as shared (common) and unique (error) influences in a path model
A-V	arterio-venous
ADA	American Diabetes Association
AIC	Akaike information criterion
AIR	acute insulin response (in minimal model IVGTT)
AIR _G	AIR corrected for glucose
ANOVA	analysis of variance
ATPIII	Adult Treatment Panel III (USA)
AUC	area under curve
BMI	body mass index
BP	blood pressure
CDCV	common disease, common variant (hypothesis)
CI	confidence interval
CIGMA	Continuous Infusion of Glucose with Model Assessment
COV	covariance
CV	coefficient of variance
ctct	cross-twin cross-trait
DBP	diastolic blood pressure
<i>df</i>	degrees of freedom
DI	disposition index
DNA	deoxyribonucleic acid
DZ	dizygotic
EGIR	European Group for the Study of Insulin Resistance
FFA	free (non-esterified) fatty acids
FFM	fat-free mass
FPI	first-phase insulin secretion in IVGTT
FSIVGTT	frequently sampled IVGTT (minimal model IVGTT)
GAD	glutamic acid decarboxylase

GCTA	genome-wide complex trait analysis
GIP	glucose-dependent insulinotropic polypeptide
GLP-1	glucagon-like peptide 1
GWAS	genome-wide association study
h^2	heritability in the narrow sense
H^2	heritability in the broad sense
HapMap	International Haplotype Map Project
HDL	high-density lipoprotein
HOMA-BETA	homeostasis model assessment estimate of beta cell function
HOMA-R, HOMA-IR	homeostasis model assessment estimate of insulin resistance
HR	hazard ratio
HRR	haplotype relative risk
HWE	Hardy–Weinberg equilibrium
IBD	identity by descent
IBS	identity by state
IC	intraclass correlation, correlation within members of a twin pair
IDF	International Diabetes Federation
IFG	impaired fasting glycaemia
IG30, IG_{30}	insulinogenic index, insulin corrected for glucose at 30 min (OGTT)
IGT	impaired glucose tolerance
Ins ₀ , Ins ₁₂₀	Fasting and 120 min (2 hour) insulin concentration in OGTT, original publication III
Intraclass r	intraclass correlation, correlation within members of a twin pair
ISI	insulin sensitivity index
ITT	insulin tolerance test
IVGTT	intravenous glucose tolerance test
K_g , k-value	glucose disappearance rate
KGMM	Kurt George Matthew Mayer
kITT	k-value in ITT
LD	linkage disequilibrium
LDL	low-density lipoprotein
LISREL	linear structural relations (software)

LPI	late-phase insulin secretion in IVGTT
LPL	lipoprotein lipase
LR	likelihood ratio
<i>M</i>	M-value, glucose uptake i.e. “glucose metabolized” in a clamp test
MAF	minor allele frequency
MCR	metabolic clearance rate
MeSH	Medical Subject Heading
MGTT	meal glucose tolerance test
MODY	maturity-onset diabetes of the young
MPlus	MPlus – software
Mx	Mx – software
MZ	monozygotic
NEFA	non-esterified (free) fatty acids
NGS	next-generation sequencing
NIH	National Institutes of Health (USA)
OGTT	oral glucose tolerance test
PPARG	peroxisome proliferator-activated receptor gamma
QUICKI	quantitative insulin sensitivity check index
QTL	quantitative trait locus
r_e	correlation between environmental variance components
RFLP	restriction fragment length polymorphism
r_g	correlation between genetic variance components
RIA	radio immunoassay
RRI	readily releasable insulin in IVGTT
SBP	systolic blood pressure
SD	standard deviation
SEM	structural equation modelling
S_1	insulin sensitivity index used in minimal model
SNP	single-nucleotide polymorphism
SOLAR	Sequential Oligogenic Linkage Analysis Routines (software)
SSLP	simple sequence-length polymorphism
$T_{1/2}$	half-life, time for a measure to reach half of its maximum

T2D	type 2 diabetes (mellitus)
TDT	transmission disequilibrium test
V_A, V_D, V_C, V_E	variance due to additive, dominant, shared (common) and unique environmental latent effects
VLDL	very low-density lipoprotein
WES	whole exome sequencing
WGS	whole genome sequencing
WHO	World Health Organization
WHR	waist-to-hip ratio
YLD	years lived with disability
λ_s	sibling relative risk

Not included in the list of abbreviations are gene names and symbols used only in equations.

3. LIST OF TABLES

Table 1. Original publications.

Table 2. World Health Organization criteria for the classification of body mass index in adults.

Table 3. The threshold values for diagnosing diabetes, impaired glucose tolerance (IGT) and impaired fasting glucose (IFG) according to World Health Organization 2006 criteria.

Table 4. Varying criteria used for the definition of insulin resistance syndrome.

Table 5. Basic statistics used in the quantitation of similarity between relatives.

Table 6. Equations for calculation of covariance between relatives.

Table 7. Population correlations in terms of bivariate model parameters for MZ and DZ twins.

Table 8. Explanation of other statistics used for quantitation of similarity between twins.

Table 9. Summary of the number of participating twin pairs.

Table 10. Statistical packages.

Table 11. Clinical characteristics of MZ and DZ twins in studies I to IV.

Table 12. Clinical characteristics of individuals in study V.

Table 13. Intraclass correlation coefficients of type 2 diabetes and selected metabolic traits from the Finnish Twin Cohort Study.

Table 14. Heritability estimates of type 2 diabetes and selected diabetes-related traits from the Finnish Twin Cohort Study (studies I to IV) and the Botnia Study (study V).

Table 15. Heritability of type 2 diabetes in different age groups in the Botnia Study (study V).

4. LIST OF FIGURES

Figure 1. Distribution of differences in weight of identical and fraternal twins and siblings (Newman 1937). With permission from the University of Chicago Press.

Figure 2. Two-compartment C-peptide model. According to Eaton 1980.

Figure 3. Glucose minimal model including hepatic glucose extraction. According to Bergman 1979.

Figure 4. Minimal model of insulin secretion. According to Bergman 1981.

Figure 5. Minimal model of glucose and C-peptide (insulin) kinetics including both oral and intravenous administration routes for glucose. Adapted from Eaton 1980, Bergman 1979, 1981, Cretti 2001, Breda 2001 and Mari 2002.

Figure 6. The main targets of insulin action (Magkos 2010). With permission from Elsevier.

Figure 7. Two-compartment model for insulin secretion and insulin sensitivity in the minimal model. According to Bergman 1979.

Figure 8. Graphical representation of the relations between gene dose of homozygotes and heterozygotes and the genotypic effect in a one-locus model with two alleles (Neale 2004). With permission from Springer Netherlands.

Figure 9. Example of a univariate (one-variable) model with a phenotypic trait P of twin pair members P_1 and P_2 and with the latent variance components. In panel a) the variances are fixed to 1.0 and the path coefficients are calculated. In b) the variance components will be estimated from data (Neale 2004). With permission from Springer Netherlands.

5. LIST OF EQUATIONS

		Page
Equation 1	HOMA-BEA index (Matthews 1985)	33
Equation 2	Incremental area under curve, AUC_1 (Yeh 1978)	35
Equation 3	Insulinogenic index (Phillips 1994)	35
Equation 4	Φ_1 , the rapid release of insulin from beta cells in response to glucose bolus (Toffolo 1980) .	38
Equation 5	Φ_2 , the second-phase pancreatic sensitivity to glucose (Toffolo 1980)	38
Equation 6	Change in total intravascular C-peptide pool as function of time according to Eaton (Eaton 1980)	39
Equation 7	Change in total extravascular C-peptide pool as function of time according to Eaton (Eaton 1980)	39
Equation 8	A linear term for the influence of glucose on beta cells in the minimal model by Bergman (Bergman 1979)	41
Equation 9	Provision of new C-peptide in response to a glucose stimulus in the minimal model by Bergman (Bergman 1979)	41
Equation 10	Dynamic secretory component of the pancreatic response to glucose according to Cobelli et al. 2001 (Breda 2001)	42
Equation 11	The static pancreatic secretory component in response to glucose (Mari 2001)	42
Equation 12	HOMA-IR index (Matthews 1985)	48
Equation 13	Quantitative insulin sensitivity check index, QUICKI (Katz 2000)	49
Equation 14	Matsuda (Matsuda–DeFronzo) insulin sensitivity index (Matsuda 1999)	49
Equation 15	Stumvoll index of insulin sensitivity (Stumvoll 2000)	50
Equation 16	Belfiore insulin sensitivity index with glycaemia correction (Belfiore 1998) .	50
Equation 17	Belfiore insulin sensitivity with FFA correction (Belfiore 1998)	50
Equation 18	Cederholm insulin sensitivity index, long version (Cederholm 1985)	50
Equation 19	Cederholm insulin sensitivity index, short version (Cederholm 1985)	51
Equation 20	Gutt index of insulin sensitivity (Gutt 2000)	51
Equation 21	Glucose uptake component in the Gutt index (Gutt 2000)	51
Equation 22	Soonthornpun index of insulin sensitivity (Soonthornpun 2003)	52
Equation 23	Glucose disappearance rate or k-value (Lundbaek 1962)	52

Equation 24	Change of glucose concentration as a function of time in the minimal model (Bergman 1979)	53
Equation 25	Change of insulin concentration in the remote compartment as a function of time in the minimal model (Bergman 1979)	53, 55
Equation 26	Change of glucose concentration as a function of time after solving for the peripheral glucose flux p_1 (Bergman 1979)	53
Equation 27	Change of glucose concentration as a function of time in the minimal model in a meal test (Caumo 2000)	55
Equation 28	Relation between glucose uptake and glucose infusion in the steady state in an insulin suppression test by (Shen 1970)	57
Equation 29	Impedance, i.e. resistance of glucose uptake to insulin (Shen 1970)	57
Equation 30	Rate of glucose metabolized in the forearm balance model (Andres 1956)	57
Equation 31	\bar{x} , arithmetic mean of a distribution	64
Equation 32	s^2 , variance	64
Equation 33	$s_{x,y}$, covariance	64
Equation 34	r , correlation	64
Equation 35	SD, standard deviation	64
Equation 36	Genetic variance partitioned to variance components	66
Equation 37	Environmental variance partitioned to variance components	66
Equation 38	Total phenotypic variance of a trait partitioned to variance components	66
Equation 39	Covariance between two family members when kinship coefficient is used	66
Equation 40	Covariance between MZ twins, using allele frequencies and genotypic effects	67
Equation 41	Covariance between MZ twins, using variance components .	67
Equation 42	Covariance between DZ twins, using allele frequencies and genotypic effects	67
Equation 43	Covariance between DZ twins, using variance components	67
Equation 44	Covariance between unrelated siblings, using allele frequencies and genotypic effects	67
Equation 45	Covariance between unrelated siblings, using variance components	67
Equation 46	Covariance between half sibs, using allele frequencies and genotypic effects	67
Equation 47	Covariance between half sibs, using variance components	67
Equation 48	Covariance between parents and offspring, using allele frequencies and genotypic effects	67

Equation 49	Covariance between parents and offspring, using variance components	67
Equations 50–52	Population correlations for trait x among MZ twins in a bivariate (x,y) model using three variance component models AE, CE and ACE (Visscher 2006)	68
Equations 53–55	Population correlations for trait x among DZ twins in a bivariate (x,y) model using three variance component models AE, CE and ACE (Visscher 2006)	68
Equations 56–58	Population correlations for trait y among MZ twins in a bivariate (x,y) model using three variance component models AE, CE and ACE (Visscher 2006)	68
Equations 59–61	Population correlations for trait y among DZ twins in a bivariate (x,y) model using three variance component models AE, CE and ACE (Visscher 2006)	68
Equations 62–64	Population correlations between traits x and y among MZ twins in a bivariate (x,y) model using three variance component models AE, CE and ACE (Visscher 2006)	68
Equations 65–67	Population correlations between traits x and y among DZ twins in a bivariate (x,y) model using three variance component models AE, CE and ACE (Visscher 2006)	68
Equations 68–70	The total population correlation between traits x and y in a bivariate (x,y) model using three variance component models AE, CE and ACE (Visscher 2006)	68
Equation 71	The sum of the variance ratios under an ACE model (Visscher 2006)	68
Equation 72	h^2 , heritability in the narrow sense	69
Equation 73	H^2 , heritability in the broad sense	69
Equation 74	The relation between MZ and DZ intraclass correlations under the presence of purely additive genetic variance	69
Equation 75	Intraclass correlation calculated using mean-squared deviations	70
Equation 76	Pairwise concordance rate	70
Equation 77	Casewise concordance rate	70
Equation 78	General equation for linear regression	70
Equation 79	General equation for least squares	70
Equation 80	Likelihood ratio (LR) for the comparison of AE and ADE models	72
Equation 81	The degrees of freedom for the LR presented in Equation 80	72

6. ABSTRACT

This study investigated the extent to which insulin action and insulin secretion, measured using oral glucose tolerance tests (OGTT), euglycaemic hyperinsulinaemic clamp technique (clamp) and intravenous glucose tolerance tests (IVGTT), are controlled for by genetic factors among middle-aged non-diabetic twins (studies I to III). Then, a large population-based cohort of twins and a generation-long follow-up were used to assess the heritability (h^2) for type 2 diabetes (T2D) (study IV). Finally, for the families participating in the Botnia Study, h^2 was estimated for an array of metabolic traits associated with T2D (study V).

A subset of the older Finnish Twin Cohort Study participated in studies I to III, consisting of 151 twin pairs: 66 monozygotic (MZ; 28 female/38 male) and 85 dizygotic (DZ; 33/52). In study IV, the complete older cohort was used, with 23,585 twins in 4,076 MZ (1,911/2,165) and 9,109 DZ (4,570/4,539) pairs. In study V, the Botnia Study, information was obtained for 25,962 individuals from 1,131 families with at least one member with T2D. The current study was restricted to families with phenotype information from at least two members: 5,810 individuals (of which 1,707 have T2D) in 942 families. The average family size was 6.17.

In studies I to III, all 151 pairs underwent an OGTT, while 42 pairs (22 MZ and 20 DZ) took part in a 160-min euglycaemic hyperinsulinaemic (45 mU/m²min) clamp preceded by a 60-min IVGTT (Botnia clamp). In study IV, the twins' self-reported weight and height from 1975 were used to assess their baseline BMI. The T2D-incidence data was collected through linking records from death certificates, the National Hospital Discharge and the Medication Registers between 1976 and 1995. Use of the Medication Register was extended until 2004. In study V, all non-diabetic individuals and those with T2D with fasting glucose less than 10 mmol·l⁻¹ underwent OGTT. Insulin sensitivity and secretion were assessed using the Botnia clamp.

Insulin-stimulated glucose uptake (M-value) was measured from the last hour of clamp. Incremental insulin secretion was obtained using the trapezoidal rule for the first 10 min (first-phase insulin – FPI) and the last 50 min (late-phase insulin – LPI) of IVGTT. In study II, a mathematical model used the IVGTT and OGTT data to assess the first- (readily releasable insulin – RRI) and second-phase (sigma) insulin secretion levels (IVGTT), as well as a global beta cell performance index (OGTT beta index).

For studies I to III, the intraclass-correlation (IC) coefficients of the MZ and DZ pairs were first compared. In study II, also cross-twin cross-trait (ctct) correlations (trait 1 of twin 1 vs. trait 2 of twin 2, and vice versa) were calculated by looking for common genetic factors between RRI and sigma. Maximum likelihood univariate analyses were used to estimate the additive (A), non-additive (D), shared (C) and unique (E) environmental components of variance for all traits of interest, using the Mx software. In studies III and IV, bivariate analyses were performed to study the latent genetic (r_g) and environmental (r_e) correlations for fasting and 2-hour insulin values (III) and BMI and T2D (IV). In study V, the h^2 values of T2D and anthropometric and metabolic traits were estimated using the SOLAR software.

In study IV, the hazard ratios (HRs) of incident T2D were calculated by categories, as integer values and as well per unit of BMI and per SD of BMI. Age-adjusted bivariate genetic factor models were estimated separately for male and female twin pairs using the mean and variance weighted least-squares method. The bivariate model yielded, along with the variance components, phenotypic correlation coefficients as well as IC, r_g and r_e .

In study I, insulin secretion (IVGTT) correlated significantly only between MZ twins, giving $h^2 = 0.55$ for FPI and 0.58 for LPI. The clamp glucose uptake had only a modest MZ correlation ($h^2 = 0.37$; $p = 0.015$).

In study II, the intraclass correlations (MZ/DZ) were 0.78/0.23 for RRI, 0.67/0.32 for sigma and 0.57/0.42 for OGTT beta index. The h^2 values were 0.76 for RRI, 0.28 for sigma and 0.53 for OGTT beta index. The ctct correlations between RRI and sigma were non-significant, indicating that they represent distinct processes.

In study III, the h^2 value of fasting insulin was 0.43. For 2-hour insulin h^2 was 0.51 in female twins, whereas in male twins, no significant evidence for a genetic effect was found. The genetic effects on fasting and 2-hour insulin levels were highly correlated ($r_g = 0.81$).

In study IV, altogether 1,332 twins (6.3% of the men and 5.1% of the women) developed T2D. The HR for T2D increased with a mean of 1.22 (95% CI 1.20–1.24) per BMI unit, 1.97 (95% CI 1.87–2.08) per SD of BMI. The HRs for normal weight, overweight, obese and morbidly obese groups were 0.59, 2.96, 6.80 and 13.64 compared with normal weight twins. The model-based h^2 values for bivariate variance due to an additive genetic component and non-shared environmental component were 0.75 (men) and 0.71 (women) for BMI, and 0.73 and 0.64, respectively, for T2D. According to the bivariate model r_g , one fifth of the covariance of BMI and T2D was due to shared genetic influences.

In study V, the strongest heritability for T2D was among those aged 35–60 years at onset ($h^2 = 0.69$). Among quantitative traits, the highest h^2 values for all individuals and non-diabetic individuals were seen for lean body mass ($h^2 = 0.53$ –0.65), HDL-cholesterol (0.52–0.61) and suppression of NEFA during OGTT

(0.63–0.76), followed by measures of insulin secretion (insulinogenic index, IG30 = 0.41–0.50) and insulin action (insulin sensitivity index, ISI = 0.37–0.40). Family means of these traits differed two- to fivefold between families belonging to the lowest and highest quartiles of the traits ($p < 0.00001$).

SUMMARY

1. Genetic factors explained most of the risk for type 2 diabetes mellitus. This conclusion is based upon the finding that genes accounted for as much as 64% of the T2D risk in female and 73% in male twins during a 28-year follow-up. The h^2 of 69% for T2D among middle-aged Botnia Study family members was in line with the twin study.

2. The variance of glucose-stimulated insulin secretion included a significant genetic component. For the intravenously stimulated first phase of insulin secretion, h^2 varied between 58% and 76%. The h^2 values of oral glucose-stimulated insulin secretion ranged from 46% to 53%.

3. The h^2 values of insulin-stimulated glucose disposal, insulin sensitivity, was 37% for the gold standard method, hyperinsulinaemic euglycaemic clamp. For surrogate techniques, the h^2 values of insulin sensitivity varied between 37% and 42%.

4. Genetic covariation with BMI explained 16% and 21% of the genetic covariance of T2D in men and women, respectively.

CONCLUSION

In the light of these twin and family studies, the majority of the risk for type 2 diabetes mellitus is due to genes. While most of the heritability of T2D remains unexplained, the early phase of the pancreatic insulin secretion appears to be an aspect of metabolism that encompasses promising phenotypes for genomic studies.

7. INTRODUCTION

The global prevalence of diabetes mellitus is surging and it was ranked as ninth in the 2010 report on the global burden of disease, defined as years lived with disability (YLD) (Vos 2012). The number of individuals with diabetes was approximated to be 118 million in 1990 (Murray 1996). Recent predictions suggest that this figure will exceed 500 million by 2030 (Wild 2004, Shaw 2010) and in more than 9 out of 10 cases that will mean type 2 diabetes (WHO 2006). The expected relative increase in the prevalence varies between 20% and 100%, being highest in Africa, the Middle East and the eastern Mediterranean region (Shaw 2010). In Finland, the 2007 the number of incident cases of type 2 diabetes was 30 000 and there were 245 000 prevalent cases, respectively. The latter has been predicted to double every 12 years (Koski 2010).

The diabetes epidemic is driven by urbanization, decreasing physical activity and increasing calorific intake, and is paralleled by the obesity pandemic. Albeit not evenly dispersed, the proportion of people who are overweight or obese is increasing in all continents. The rate is already high in European and North American countries, higher in the Pacific region and varies more among African and Middle Eastern countries (Prentice 2006). According to the WHO, since 1980 worldwide obesity has more than doubled (WHO 2013). In 2008, 1.5 billion adults aged 20 or older were overweight having a BMI over $25 \text{ kg}\cdot\text{m}^{-2}$. Of these, over 200 million men and nearly 300 million women were obese, i.e. their BMI was over $30 \text{ kg}\cdot\text{m}^{-2}$. In 2010, nearly 43 million children under five were overweight. In Finland, between 1978 and 2010 the proportion of overweight adults increased from 42% to 58% among men, and from 37% to 50% among women (Helakorpi 2011).

Type 2 diabetes develops as a consequence of relative hypoinsulinaemia and insulin resistance of glucose metabolism in the liver and peripheral tissues, especially in skeletal muscle. The progress and changing views of the pathophysiology of type 2 diabetes is illustrated by two ADA award lectures from 1987 and 2008, by Ralph DeFronzo. In the Lilly Lecture 1987 (DeFronzo 1988), he nominated three disturbances, a “triumvirate”, as responsible for chronic hyperglycaemia: skeletal muscle insulin resistance and decreased glucose uptake, impaired insulin secretion by pancreatic beta cells and increased hepatic glucose production. In the Banting Lecture 2008, amid global escalation of both the type 2 diabetes pandemic and its research, the triumvirate had evolved to an octet (DeFronzo 2009). The additional five members were: overproduction of glucagon from pancreatic alpha cells, decreased influence of gut incretin hormones, increased lipolysis in adipose tissue, increased glucose reabsorption in the kidneys and an impaired neurotransmitter function in the parts of the brain regulating glucose homeostasis. In addition to

these, at least impaired ability of subcutaneous adipose tissue to expand under a fuel surfeit, hyperadiponectinaemia and chronic inflammation of adipose tissue have been suggested (Nolan 2011), suggesting defects in multiple pathways cause type 2 diabetes.

Our group was among the first to demonstrate, that healthy first-degree relatives of type 2 diabetes patients needed less external glucose to keep their plasma glucose normal during hyperinsulinaemia (Eriksson 1989). In other words, they were insulin resistant. The method used in the study, the hyperinsulinaemic euglycaemic clamp test, was and is still regarded as the gold standard for quantifying insulin sensitivity (DeFronzo 1979, Muniyappa 2008). Camilla Schalin-Jääntti from our group showed in 1992 that normoglycaemic but insulin-resistant relatives of type 2 diabetes patients had impairment in the action of glycogen synthase in their skeletal muscle (Schalin-Jääntti 1992). Taken together, these findings implied that an inherited defect in skeletal muscle might render offspring of type 2 diabetes patients vulnerable to the same disease.

These findings set in motion a Finnish, later Finnish–Swedish, effort to find out which metabolic defects are inherited in families with type 2 diabetes. The Botnia Study was initiated in 1990 in four Ostrobothnia primary health-care units (a fifth was added in 1992). It collected data from all families with type 2 diabetes in the region (Groop 1996), and since then it has grown to become one of the leading projects in the world focusing on type 2 diabetes genetics (Demenais 2003).

At the same time as the onset of the Botnia Study, a population-based Finnish twin study on the cumulative incidence, concordance and heritability of both type 1 and type 2 diabetes was conducted by Helsinki University (Kaprio 1992). The twins were identified using the Finnish Twin Cohort Study, which is a national resource for genetic epidemiological studies (Kaprio 1978, 1994). Somewhat unexpectedly, heritability for type 1 diabetes was found to be higher than for type 2 diabetes (Kaprio 1992).

There were, thus, two differing results regarding the importance of genetic factors for the risk of type 2 diabetes. Even the apparently healthy first-degree relatives of the type 2 diabetes patients seemed to be insulin resistant, while a population-based actuarial study showed only modest concordance between MZ twins. We hypothesized that by applying the classical twin study approach to non-diabetic subjects, who would undergo assessment of insulin sensitivity as measured with clamp, we could get an answer to the question: is insulin sensitivity an inherited trait? The preliminary discussions between the two research groups were successful and in addition to euglycaemic hyperinsulinaemic clamp, an intravenous glucose tolerance test was added to the protocol. The rationale was that type 2 diabetes manifests only when insulin secretion fails to overcome peripheral insulin resistance.

Both the Botnia and Twin Cohort studies thrived. They yielded large amounts of information regarding type 2 diabetes and metabolic traits both within families

and during a long follow-up of more than 15 years. That was why the original study protocol including non-diabetic twin pairs was amended to estimate the heritability of metabolic traits within a large number of families with type 2 diabetes. In addition, as time had passed, there was an opportunity to return to the same twins used for the 1992 *Diabetologia* article, and re-estimate heritability for type 2 diabetes after a generation-long follow-up.

8. REVIEW OF THE LITERATURE

8.1 TYPE 2 DIABETES MELLITUS AND RELATED METABOLIC DISTURBANCES

8.1.1 OBESITY

Definition and diagnosis of obesity

The World Health Organization (WHO) defines overweight and obesity as abnormal or excessive fat accumulation that may impair health. They are caused by the energy imbalance between calories consumed and expended (WHO 2013). According to the Medical Subject Heading Browser (MeSH, http://www.nlm.nih.gov/mesh/2013/mesh_browser/MBrowser.html), obesity is “a status with body weight that is grossly above the acceptable or desirable weight, usually due to accumulation of excess fats in the body. The standards may vary with age, sex, genetic or cultural background.” The word “obesity” comes from the Latin expressions *ob*, meaning “against” or “over”, and *edere*, “to eat” (Waife 1955).

Assessment of obesity

The assessment of obesity extends from an estimation of ponderosity to an estimation of the amount and distribution of bodily fat tissue. These may include: (1) comparing measured weight with the population average or a desirable weight obtained from respective weight tables, (2) calculating indices based on height and weight, (3) quantifying the amount of subcutaneous fat, (4) estimating whole body fat mass with a variety of techniques, (5) estimating the proportion of intra-abdominal fat either indirectly by measuring waist or waist and hip circumferences or directly with the use of X-ray or magnetic resonance imaging techniques (Lehtovirta 1973, Kissebah 1982, Ashwell 1985, Franssila-Kallunki 1992, Ross 1992, Browning 2010).

Belgian mathematician and polymath Adolphe Quetelet developed the best-known measure of obesity (Eknayan 2008). In his 1835 published book entitled *A Treatise of Man and the development of his faculties* (English translation: Quetelet 1842), Quetelet showed, that other than growth spurts after birth and during puberty, weight of an average man increases as the square of the height (Quetelet 1842, Eknayan 2008). The epidemiological validity of the Quetelet Index, or ponderal index, was first confirmed in the Framingham study (Floreay 1970), and renamed as Body Mass Index, BMI, by epidemiologist Ancel Keys (Keys 1972). Although the specificity of BMI to detect people with excess adiposity is

high, it is not a sensitive measure: as many as every other individual with normal BMI may yet have excess adiposity (Okorodudu 2010). However, because of its affordability and universal availability, BMI has maintained the position as the gold standard in the classification of adiposity among adults (Table 2) (WHO 2000).

Table 2. World Health Organization criteria for the classification of body mass index in adults.

Classification	BMI (kg·m ⁻²)	
	Principal cut-off points	Additional cut-off points
Underweight	< 18.50	< 18.50
Normal range	18.50–24.99	18.50–22.99
		23.00–24.99
Overweight	≥ 25.00	≥ 25.00
Pre-obese	25.00–29.99	25.00–27.49
		27.50–29.99
Obese	≥ 30.00	≥ 30.00
Obese class I	30.00–34.99	30.00–32.49
		32.50–34.99
Obese class II	35.00–39.99	35.00–37.49
		37.50–39.99
Obese class III	≥ 40.00	≥ 40.00

Genetics of obesity

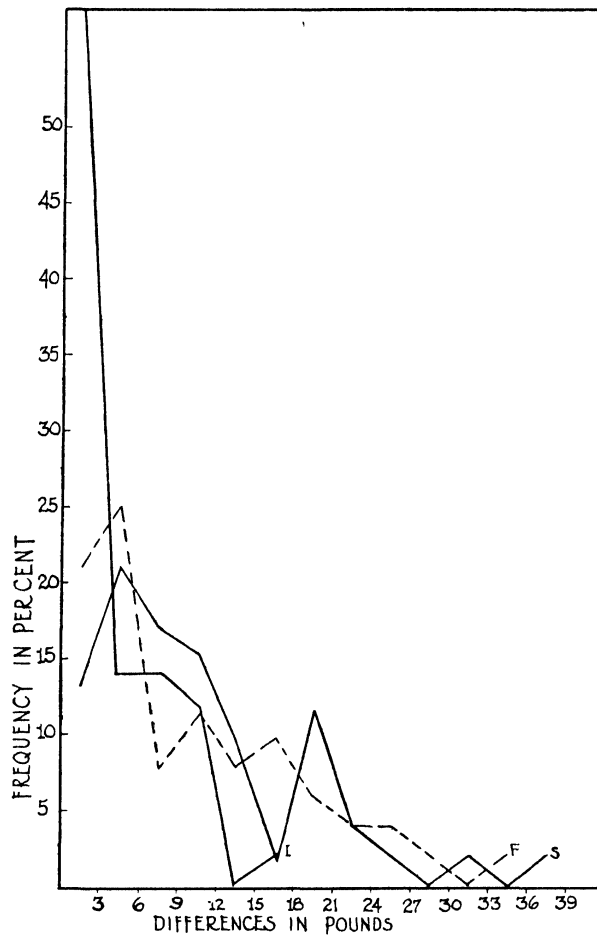

Figure 1. Distribution of differences in weight of identical and fraternal twins and siblings (Newman 1937). With permission of the University of Chicago Press.

Although Sir Francis Galton described the familial clustering of stature and collected a large dataset of anthropometric measures including weight, he did not differentiate “nature from nurture” (Galton 1889). Several researchers confirmed the resemblance of weight between family members some decades later (Davenport 1923). In the twin study by Newman et al., a striking similarity of weights of identical twin pair members was observed, compared to those among fraternal twin pairs and sibling pairs. The authors concluded that the difference must be due to genetic factors and that environmental factors are more important in the variability of weight than for height (Newman 1937). The contribution of genetic factors to weight, and weight

gain, were confirmed by MZ overfeeding studies (Bouchard 1990) and studies of twins reared apart (Stunkard 1990). According to population-based follow-up data from the Finnish Twin Cohort Study, the h^2 values of baseline BMI were 0.80 in male twins and 0.82 in female twins and the h^2 values for the rate of change of BMI from early adulthood to middle age were 0.58 and 0.64, while the respective genetic correlations between baseline and the rate of change were only -0.07 and 0.04 (Hjelmborg 2008).

Monogenic and syndromic forms of obesity are rare (Bell 2005) and the preponderant inheritance mode for obesity seems to be associated with polymorphisms in multiple genes (Cheung 2012). James Neel proposed in his “thrifty genotype” hypothesis in 1962 that genes and gene combinations, selected in the ancient environment of scarcity, have been rendered detrimental in modern environments where plenty of food is available without disruption (Neel 1962). Other obesogenic genotypes include those influencing satiety, levels of physical activity, lipid oxidation and adipogenesis (Bouchard 2007). It is, however, the environment that provides the major stimulus for the globally observed increase in overweight and obesity.

The latest version of the Human Obesity Gene Map from 2005 reports 176 individual cases of obesity caused by a single gene defect and 253 QTLs from 61 genome-wide location studies, including 52 regions supported in more than two studies (Rankinen 2006). Since then, genome-wide association studies (GWASs) have provided at least 52 new obesity-associated trait gene regions (Loos 2012), the most promising among them being the fat mass and obesity gene (FTO) (Frayling 2007) and a locus near the melanocortin 4 receptor (M4CR) gene (Farooqi 2003, Chambers 2008). Despite the abundance of obesity-related gene regions, their combined contribution to the trait variance was found to be less than 5% in 2010 (Speliotes 2010). One of the most recent genome-wide complex trait analyses (GCTAs) estimated that common variant heritability of BMI is 20% (Visscher 2012).

8.1.2. TYPE 2 DIABETES MELLITUS

Definition and diagnosis of type 2 diabetes

Type 2 diabetes mellitus and intermediate forms of hyperglycaemia lie on a continuum of metabolic disturbances where blood (plasma) glucose concentration exceeds the normal range either in the postprandial or fasting state or in both states (WHO 2006). The current WHO threshold values for diagnosing diabetes, impaired glucose tolerance (IGT) and impaired fasting glycaemia (IFG) are shown in Table 3 (WHO 2006).

Table 3. Threshold values for diagnosing diabetes, impaired glucose tolerance (IGT) and impaired fasting glycaemia (IFG) according to the World Health Organization's 2006 criteria.

Value	Diabetes	Impaired glucose tolerance (IGT)	Impaired fasting glycaemia (IFG)
Fasting plasma glucose	≥ 7.0 mmol·l ⁻¹ (126 mg·dl ⁻¹)	< 7.0 mmol·l ⁻¹ (126 mg·dl ⁻¹)	6.1–6.9 mmol·l ⁻¹ (110–125 mg·dl ⁻¹)
	or	and	and, if measured
2-hour plasma glucose*	≥ 11.1 mmol·l ⁻¹ (200 mg·dl ⁻¹)	≥ 7.8 mmol·l ⁻¹ (140 mg·dl ⁻¹) and < 11.1 mmol·l ⁻¹ (200 mg·dl ⁻¹)	< 7.8 mmol·l ⁻¹ (140 mg·dl ⁻¹)
Random glucose	≥ 11.1 mmol·l ⁻¹ (200 mg·dl ⁻¹) with classic symptoms		
HbA1C	$\geq 6.5\%$		

* 2-hour plasma glucose is the venous plasma glucose level 2 hours after ingestion of 75 g oral glucose load. If it cannot be measured, the diabetic status is rendered unclear as diabetes or IGT cannot be excluded.

Epidemiology of type 2 diabetes

Type 2 diabetes seems to cluster in families regardless of ethnicity (Knowler 1981, Köbberling 1982, Gardner 1984, Shaten 1993, Mitchell 1993, Lee 1995, Bjørnholt 2000, Meigs 2000, Sargeant 2000, Erasmus 2001). A family history of type 2 diabetes has been associated with defects in insulin action, insulin secretion or both (Lillioja 1987, Eriksson 1989, Vauhkonen 1998). The sibling relative risk of type 2 diabetes, compared to the risk for the background population, is around 3 (Lyssenko 2005). Having one parent with type 2 diabetes increases the lifetime risk for an offspring for the same disease by 40%. If both parents are affected, then the offspring risk for diabetes is 70% (Köbberling 1982, Groop 1996). Twin studies have provided support for the hypothesis that there are genetic influences on type 2 diabetes, both from the higher concordance rates in MZ than in DZ twins and from the significant h^2 estimates (Then Berg 1938, Harvald 1963, Gottlieb 1968, Pollin 1969, Tattersall 1972, Pyke 1976, 1978, 1979, Barnett 1981a, 1981b, Köbberling 1982, Newman 1987, Anon 1988, Kaprio 1992, Matsuda 1994, Medici 1999, Poulsen 1999). Using population-based Finnish twin data, the h^2 for type 2 diabetes was calculated as 79% (Kaprio 1992).

Genetics of type 2 diabetes

Although it is axiomatic that environmental factors drive diabetogenesis, it is as evident that major differences exist in the individual responses to fuel surfeit. These differences have genetic origins. Understanding the genetics of type 2

diabetes has increased through technological innovation. The candidate gene approach is based on a known function of a gene for a trait and on the search for the association of these gene variants with the trait in the study population. Genes for peroxisome proliferator-activated receptor gamma (PPARG) (Deeb 1998), potassium inwardly-rectifying channel, subfamily J, member 11 (KCNJ11) (Hani 1998), insulin receptor substrate-1 (IRS1) (Almind 1993), hepatocyte nuclear factor 1 homeobox B (HNF1B) (Winckler 2005) and Wolfram syndrome 1 (wolframin, WFS1) (Minton 2002) are the few type 2 diabetes genes that have been found by identifying candidate genes. An earlier approach was linkage analysis, which used 400–500 markers covering the entire genome. The search for linkages using data from affected families identified two genes: calpain 10 and transcription factor 7-like 2 (Hanis 1996, Grant 2006).

The identification of single-nucleotide polymorphism (SNP) variations enabled simultaneous genotyping of hundreds of thousands of SNPs. This, especially via the International Haplotype Map Project, HapMap (International HapMap Consortium 2005), paved the way for genome-wide association studies of type 2 diabetes, several of which were published between 2007 and 2009. These were followed by three large meta-analyses, which combined information from several GWASs and extended SNP coverage (Saxena 2007, Scott 2007, Zeggini 2007, Sladek 2007, Steinthorsdottir 2007, The Wellcome Trust Case Consortium 2007, Unoki 2008, Yasuda 2008, Tsai 2010, Kong 2009, Jonsson 2009, Zeggini 2008, Qi 2010, Dupuis 2010).

At present more than 65 type 2 diabetes gene loci have been identified. More than half are associated with beta cell function and insulin secretion, five are associated with insulin sensitivity and one, the fat mass and obesity (FTO) gene, with BMI (Dina 2007, Frayling 2007). Most rare monogenic forms of type 2 diabetes seem to result from defects in insulin secretion (Murphy 2008). Despite the impressive number of loci found, they are estimated to explain only 10–15% of the total variance of type 2 diabetes. The rest, sometimes called the “genetic dark matter” or “missing heritability”, is assumed to consist of rare (low frequency) genetic variants, gene–gene interactions and epigenetic phenomena (Sparsø 2009; Simmons 2007).

8.1.3 INSULIN SECRETION

Insulin was originally discovered in 1921 and named pancreine by Nicolae Paulescu, a Romanian physician. However, the published work of the Canadians George Banting and Charles Best led to the recognition of insulin as a treatment for diabetes in 1922 (Banting 1922). For this, Banting and his supervisor John Macleod received the Nobel Prize for physiology or medicine in 1923. James Collip, who purified the insulin extract, was nominated years later (1935) and Best as late as 1950 (de Leiva-Pérez 2010). Measuring insulin secretion and insulin sensitivity were not

possible until the development of the radioimmunoassay of insulin by Rosalyn Yalow and Solomon Berson in 1960 (Yalow 1960), another discovery awarded the Nobel Prize (Kahn 2004).

Physiology of insulin secretion

Insulin is a small 51-amino acid polypeptide hormone, which has a major role in the regulation of glucose metabolism, directly by suppressing endogenous glucose production and indirectly by suppressing glucagon secretion and lipolysis. Native insulin is a globular protein with a zinc-coordinated hexamer. Each insulin monomer contains two chains, A (21 residues) and B (30 residues), linked by two disulphide bonds (Conlon 2001). The precursor protein of insulin, proinsulin (Steiner 1967), is formed in the rough endoplasmic reticulum of beta cells, and then it moves to the Golgi region, where its enzymatic cleavage to insulin and C-peptide is initiated (Steiner 1969). Insulin and C-peptide are stored in storage granules in equimolar amounts, and secreted to the circulation in an active exocytotic process (Steiner 2004). When nutrients evoke insulin secretion, the beta cell response is biphasic (Curry 1968). The first phase can also be triggered by other, non-metabolizable stimuli (Rorsman 2003). It is assumed that the slower second phase is energy dependent. Less than 5% of insulin-containing exocytotic granules constitute a readily releasable pool, which can be mobilized immediately (Rorsman 2000). The first phase has been shown to undergo a selective loss before type 2 diabetes ensues (Ward 1984).

The oscillatory manner of insulin secretion was detected in the late 1970s (Goodner 1977, Lang 1979) and was explained by the existence of a “pancreatic pacemaker” (Lang 1981). Kenneth Polonsky, by deconvoluting peripheral C-peptide concentrations, demonstrated that both 8–15 min as well as ultradian (1.5–2 h) oscillations are present (Polonsky 1988). The former persisted despite deterioration of glucose homeostasis while both the temporal and amplitude characteristics of the latter changed during the transition from normal glucose tolerance to type 2 diabetes (Polonsky 1995). Today it is assumed that delivery of portal insulin from the pancreas occurs with a steady interval of approximately 5 min between bursts. The amplitude and, hence, the mass of insulin in each burst varies depending upon the secretory stimuli (Meier 2005). Recent research suggests that the pulsatile secretion results from two superimposing oscillations in the beta cells: metabolically controlled ones, less dependent on plasma glucose concentration, as well as fast ones, which affect the amount of insulin in the bursts (Bertram 2007). Matveyenko demonstrated for dogs and rats that hepatic insulin resistance, an early defect in diabetes, follows a deterioration in timing of the pancreatic insulin bursts (Matveyenko 2012).

In addition to impaired beta cell function, cumulating evidence supports the role of diminished beta cell mass in the pathogenesis of type 2 diabetes (Butler 2003, Kahn 2008) although reliable methods to assess both beta cell function and mass are not yet available (Kahn 2008); therefore most results for impaired beta cell function and reduced beta cell mass in type 2 diabetes are not conclusive (Rahier 2008).

Genetics of insulin secretion

The first studies of insulin secretion to use twins were Scandinavian. Erol Cerasi and Rolf Luft from Sweden studied diabetes discordant MZ twin pairs using intravenous glucose infusions (Cerasi 1967) and concluded in 1967 that a “low insulin response” indicated an increased genetic risk for diabetes. Allan Vaag et al. from Denmark confirmed the findings by applying both euglycaemic and hyperglycaemic clamps to MZ twins discordant for type 2 diabetes in 1995 (Vaag 1995). Our group (Eriksson 1989) was among the first (O’Rahilly 1986, Bogardus 1989, Pimenta 1995) to illustrate the same among non-diabetic family members of individuals with type 2 diabetes. Steven Elbein et al. obtained the first estimate for insulin secretion h^2 values as late as 1999. They studied 120 individuals from sibships where at least one sib had type 2 diabetes. The h^2 values for the acute insulin response to intravenous glucose was 38% in all and 33% in normoglycaemic subjects, and 67% and 70% when insulin sensitivity was accounted for, respectively (Elbein 1999). The lack of population-based h^2 values for insulin secretion motivated us to perform the studies included in the current thesis.

The first few years of GWASs almost quadrupled the number of genetic loci associated with type 2 diabetes (Sparsø 2009) and most novel loci were involved in beta cell function. Schäfer et al. classified the loci into those affecting: (1) glucose-stimulated insulin secretion, (2) proinsulin to insulin conversion and (3) incretin secretion or incretin sensitivity (Schäfer 2011). One of the main type 2 diabetes risk genes, TCF7L2, interferes with all three mechanisms (Lyssenko 2007).

In general, the study of the genetics of insulin secretion is and will be dependent on how precisely the respective phenotype can be defined. Accordingly, diabetes risk estimation is and will be based upon clinical criteria, not upon individual risk genotypes (Herder 2011).

Assessment of insulin secretion

Measuring insulin secretion from plasma insulin concentrations involves a compromise: 50–80% of the secreted insulin is extracted during the hepatic first pass, which also attenuates the amplitude of the insulin secretory bursts by a factor of 100

(Polonsky 1995, Meier 2005). Furthermore, insulin clearance decreases in response to hyperglycaemia (Byrne 1995). In addition, both the variability of insulin assays as well as the satiability of the whole body insulin clearance must be taken into account in the reconstruction of the actual secretory pattern of beta cells (Camastra 2007).

Basal insulin secretion is usually estimated from samples of plasma taken after an overnight fast of 10 to 12 hours. Tests of stimulated insulin secretion are based on introducing a finite amount of glucose or a secretagogue, either intravenously or orally, and sampling plasma to estimate insulin or C-peptide concentrations. The interpretation of the results using oral glucose loads differs from that of using intravenous glucose because orally administered nutrients stimulate the secretion of several gastrointestinal peptides, incretin hormones like GLP-1 and GIP, which further stimulate insulin secretion during a meal and modulate pancreatic glucagon responses (Rask 2004).

In the following, I have compiled a description of the methods used to assess insulin secretion. Because the minimal model and C-peptide kinetics constitute a central theme in the study of beta cell function in vivo, they are in a separate section.

Fasting values and indices

Fasting insulin concentration

Although often used to mean the basal insulin secretion, the fasting plasma insulin concentration reflects both insulin secretion between meals as well as the insulin sensitivity of glucose metabolism, and thus is merely a proxy for insulin resistance and basal insulin clearance (Ferrannini 2003). This, of course, has not prevented researchers from using it and its derivatives as measures for beta cell function (Bille 2011).

Homeostasis model assessment of insulin secretion: the HOMA-BETA index

The assumption that the pancreas and liver function using a negative feedback loop led Robert Turner et al. to model an interaction where fasting glucose and insulin concentrations reflect both the degree of beta cell deficiency and insulin resistance (Turner 1979). While the most cited outcome of the work by Matthews has been the insulin resistance index, HOMA-IR (Matthews 1985), the work also yielded the basis for the beta cell index known as HOMA-BETA. It quantitates the percentage of beta cell capacity of an individual compared to that of an “ideal individual” younger than 35 years with maximal beta cell capacity. The calculation of the HOMA-BETA index is simple:

$$\text{HOMA-BETA} = 20 \cdot \text{insulin} \div (\text{glucose} - 3.5) \quad (\text{Equation 1})$$

It is, however, difficult to interpret beta cell function without a secretory stimulus. We, among others, have shown that HOMA-BETA is a poor predictor of first-phase insulin secretion (Tripathy 2004). Festa et al. concluded that HOMA-BETA has practically no value in detecting beta cell secretory defects in individuals with impaired glucose metabolism (Festa 2008).

Non-steady-state methods

When administered orally, glucose and nutrients evoke an integrated pancreatic response due both to an increase of plasma glucose and to activation of the entero-insular axis, i.e. the incretin system (McIntyre 1965, Diab 2010). In epidemiological studies, oral tests have been favoured because of their simplicity and affordability. In a clinical setting, a standard 2-hour OGTT is regarded as the gold standard method for the clinical diagnosis of type 2 diabetes.

Oral glucose tolerance test (OGTT)

In the oral glucose tolerance test, blood samples are taken before and at least 2 hours after ingestion of 75 g glucose. These are used in diabetes clinics to characterize individual glucose tolerance status and as a research tool to assess insulin secretion and insulin sensitivity simultaneously.

The glucose dose has varied between 50 g and 100 g, and has been assessed as 1 g per kg weight (Svensgaard 1931, WHO 1965). The current standard regimen requires fasting and the administration of 75 g dextrose in 250–350 ml solution. Glucose levels are measured at least 2 hours later. This was recommended by the WHO in 1980 (WHO 1980). Insulin concentrations were measured in OGTT as soon as this became possible, but they have only been used for research. During the GWAS era, a need for more detailed metabolic phenotypes increased interest in insulin sensitivity indices. The utility of the vast epidemiological OGTT databases has, therefore, also increased.

In practice: After fasting glucose and insulin samples have been drawn, 75 g of glucose in 250–350 ml solution is ingested. Venous blood is sampled at 30, 60, 90 and 120 min later to determine plasma glucose, insulin and/or C-peptide levels. The timing of ingestion has been shown to affect entero-insular responses and the glucose disappearance rate (Heine 1983); however, no detailed OGTT instructions have been made available. In clinical use, the most prevalent protocol includes samples only at the baseline and after 120 min. Extended OGTTs may include taking multiple samples during 240–300 min (Cobelli 2007). Instead of insulin, C-peptide concentrations have been increasingly used to estimate beta cell function, especially when diabetic patients are studied (Toyota 1977, Eaton 1980, van Cauter 1992).

OGTT-derived insulin secretion indices

Insulin area under OGTT curve (0–120 min)

With the OGTT type of data with repeated measures where both the magnitude and the distance from a neighbouring value define each data point, it is feasible to use the area under the curve (AUC) to summarize the information (Fekedulegn 2007). Most researchers use the trapezoidal method for this (Yeh 1978). The commonest way to quantitate insulin secretion has been to calculate the incremental AUC (AUC_I), which takes into account the increase of insulin concentration above the fasting level. The equation for this is:

$$AUC_I = \left(\sum_{i=1}^{n-1} \frac{1}{2} \cdot (m_{(i+1)} + m_i) \cdot t_i \right) - \left(m_i \cdot \sum_{i=1}^{n-1} t_i \right) \quad (\text{Equation 2})$$

where t_i is the individual time distance between measurements, m_i is the individual measurement and n is the total number of measures.

One of the limitations of AUC_I is that it may yield negative values. Some authors set negative areas to zero and report only positive AUC_I values but this introduces a bias into the variability of the data (Le Floch 1990). Fekedulegn et al. recommend that the biological characteristics of the trait in question should determine the most optimal measures (Fekedulegn, 2007). This implies, for instance, that the secretory dynamics of the hormone should be taken into account: in addition to AUC_I , the maximal concentration, average concentration and the time from stimulus to maximal concentration may characterize the trait.

Insulinogenic index (IG_{30} or $IG30$)

Originally introduced in 1959 by Holbrooke Seltzer and Walter Smith, the insulinogenic index was defined as the 1-hour incremental insulin level divided by the incremental glucose concentration after ingestion of 100 g of glucose (Seltzer 1959). The purpose was to define the insulin secretion capacity in subjects whose glucose tolerance varied from healthy to overt diabetes. The most common version of the insulinogenic index is the ratio of the incremental increase of insulin and glucose levels during the first 30 min of OGTT (Phillips 1994):

$$\frac{\Delta Ins30'}{\Delta Gluc30'} \quad (\text{Equation 3})$$

The insulinogenic index was originally calculated using either the OGTT or the IVGTT (Seltzer 1967, Cerasi 1975) but currently OGTT is preferred (Tripathy 2004).

Intravenous glucose tolerance test (IVGTT)

The intravenous glucose tolerance test uses a single intravenous bolus of glucose after which plasma samples are collected to reconstruct the pancreatic insulin secretory response elicited by the bolus.

In practice: A simple modern version of IVGTT consists of a short intravenous infusion of 50% glucose with a dose of $0.3 \text{ g}\cdot\text{kg}^{-1}$. Samples for plasma glucose and insulin are taken at 0, 2, 4, 6, 8, 10, 20, 30, 40, 50 and 60 min later (Tripathy 2003). The minimal model and FSIVGTT will be discussed later.

Various numbers of blood samples have been used and variability also exists regarding the method. The glucose dose can be between $0.3 \text{ g}\cdot\text{kg}^{-1}$ and $0.5 \text{ g}\cdot\text{kg}^{-1}$ (Bingley 1992), the maximal glucose dose between 25 g (Henriksen 2010) and 35 g (Bingley 1992) and the concentration of glucose solution between 20% (Colman 1992) and 50% (Smith 1988). The infusion time has varied between 1 min and 2 min (Coates 1995). These factors tend to affect the early insulin response most (Colman 1992).

As insulin secretion is related to glucose tolerance, a bolus of $0.5 \text{ U}\cdot\text{kg}^{-1}$ of short-acting insulin (Coates 1995) or 300–500 g of tolbutamide (Beard 1986) has been given at 20 min, in some studies at 8 min (Valle 1998), to verify the maximal insulin effect on glucose removal.

The current way to calculate insulin secretion from IVGTT is to calculate two incremental insulin areas: an early (first) phase insulin secretion, calculated as the incremental insulin area between 0 min and 10 min after glucose infusion, and a late (second) phase, as the incremental insulin area between 10 min and 60 min after glucose infusion (Tripathy 2003).

Graded glucose infusion

The graded glucose infusion technique and the hyperglycaemic clamp test (see below) are similar and differ mainly in the predetermination of the plasma glucose level in the latter and the use of C-peptide deconvolution in the former.

Ken Polonsky et al. from the University of Chicago introduced the modern version of graded glucose infusion (Byrne 1995). Their work was based on pancreas perfusion experiments and studies of consecutive glucose boluses in “staircase”-like dosing by Gerold Grodsky (Grodsky 1972, Karam 1974). In Polonsky’s study, glucose infusions of 1, 2, 3, 4, 6 and 8 mg/kg weight, each lasting 40 min, were used and glucose and C-peptide concentrations measured every 10 min. Individual C-peptide kinetics were resolved and the insulin secretion rate estimated using a two-compartmental model (Byrne 1995).

Other secretagogues

Glucagon was shown to be a useful insulin secretagogue in 1965 (Samols 1965). The 6-min glucagon test using C-peptide concentrations to reflect beta cell function was

validated by Ole Faber and Christian Binder from Hvidovre Hospital in Denmark in 1977 (Faber 1977). The test is mainly used to estimate the residual insulin secretion capacity in diabetic patients. The amino acid arginine on its own acts as a moderate stimulator of insulin secretion, but with glucose it is a potent stimulator of insulin secretion (Gerich 1974). It was first used to study insulin and glucagon secretion (Palmer 1976) and later it was used to measure the maximal residual insulin secretory capacity (Ward 1984). Yalow demonstrated in 1960 that a potassium channel blocker, the sulphonylurea drug tolbutamide, was able to elicit a short but intensive burst of insulin from beta cells (Yalow 1960). Cerasi et al. later showed that the duration of the effect was dependent upon the glucose concentration (Cerasi 1969). Tolbutamide is currently used with FSIVGTT to produce a sufficient insulin peak to estimate glucose disappearance and insulin sensitivity (Beard 1986).

Steady-state methods: hyperglycaemic clamp

In a hyperglycaemic clamp test, a square wave of glucose infusion is used to increase plasma glucose to a chosen level in association with frequent sampling for insulin (DeFronzo 1979).

In practice: A variable 2-hour intravenous infusion of 20% glucose solution with a 15-min priming dose is administered to increase the venous plasma glucose concentration with to $6.9 \text{ mmol}\cdot\text{l}^{-1}$ (125 mg/dl in the original publication) (DeFronzo 1979). The variable rate of the glucose maintenance infusion is computed every 5 min taking into account both the glucose needed to cover the amount of glucose metabolized as well as the amount needed to account for the concentration change in the total glucose distribution space.

The simplest way to measure insulin secretion during a hyperglycaemic clamp test is to use the glucose-corrected insulin AUC_t or, alternatively, the sum of the insulin concentrations from the first 10 min (first-phase insulin secretion) and the glucose-corrected incremental mean insulin concentration from the last 60 min (second-phase insulin secretion) (Mitrakou 1992). A minimal model approach can also be used with hyperglycaemic clamp insulin and/or C-peptide data (Weiss 2005).

Minimal model and approaches to insulin secretion using C-peptide kinetics

The reason for the extensive review of minimal model and C-peptide kinetics here is twofold. First, we used an adjusted minimal model in study II. Second, while the euglycaemic clamp is the gold standard for measuring glucose uptake, the minimal model has been widely used to study insulin secretion using both

OGTTs and IVGTTs. The following includes both an introduction to estimating insulin secretion according to the original publication (Bergman 1981) as well as a short review of minimal models applied to C-peptide kinetics. The minimal model assessment of insulin sensitivity is presented in section Insulin action.

Richard Bergman, Claudio Cobelli et al. fitted variable compartmental models to FSIVGTT glucose and insulin data and chose a non-linear model, which included the hepatic glucose input and output, for the glucose kinetics (Bergman 1979) and a model with two separate pancreatic responses to glucose for the insulin secretion (Bergman 1981). After the implementation of C-peptide kinetics, the minimal model has been widely used to study beta cell function under different in vivo settings. It can be used with IVGTT, OGTT and meal tests as well as to hyperglycaemic clamp tests.

In FSIVGTT, a 60-sec intravenous infusion of 50% glucose at a dose of $0.3 \text{ g}\cdot\text{kg}^{-1}$ is administered. Blood samples are collected at 0, 2, 4, 6, 8, 10, 12, 14, 16, 19, 22, 27, 32, 42, 52, 62, 72, 82, 92, 102, 122, 142, 162 and 182 min to estimate plasma glucose, insulin and/or C-peptide levels (Bergman 1981).

Minimal model of insulin secretion

Analogously with non-modelled approaches to IVGTT and hyperglycaemic clamp testing, in the minimal model the pancreatic response after a glucose bolus is divided into two components. These are called the first- and second-phase pancreatic sensitivity, or responsiveness, to glucose: ϕ_1 and ϕ_2 (Toffolo 1980), respectively. The term ϕ_1 represents the (rapid) release of insulin from beta cells in response to the glucose bolus and can be expressed with the equation:

$$\phi_1 = \frac{I_o}{n \cdot \Delta G} \quad (\text{Equation 4})$$

I_o is the incremental value of the peak plasma insulin concentration following glucose administration, n is a time constant for insulin disappearance and ΔG is the maximal incremental glucose concentration increase. In other words, ϕ_1 is the incremental maximal insulin concentration corrected for the incremental glucose concentration.

The second-phase pancreatic sensitivity to glucose (ϕ_2) is calculated as:

$$\phi_2 = \gamma(G(t) - h) \cdot t - n \cdot I(t) \quad (\text{Equation 5})$$

In the equation, γ is the glucose sensitivity of beta cell response, $G(t)$ is the glucose concentration at each time moment (t), h is a glucose threshold for the beta cells response and $I(t)$ is the plasma insulin concentration at each time moment.

There is no consensus about the terminology: I_o has also been termed the “acute insulin response” (AIR) (Nittala 2006), and AIR_g (AIR corrected for glucose) has

been used as a synonym for ϕ_I . Several authors, furthermore, use these acronyms, AIR and AIR_g, without using the minimal model but AUC calculations instead.

As the relation between beta cell function and insulin sensitivity has been shown to be hyperbolic (Turner 1979), the authors tested the separate products of either ϕ_I or ϕ_2 and the minimal model insulin sensitivity index S_I , and in the original study concluded that the latter, $\phi_2 \cdot S_I$ was the best single measure to separate glucose intolerant from glucose tolerant subjects (Bergman 1981). The product, known as the disposition factor or disposition index (DI), has been widely estimated using other measures for insulin sensitivity and secretion (Dorkhan 2008, Laakso 2008).

Insulin secretion using C-peptide concentrations

The inter-individual volatility of insulin disappearance can be circumvented by using C-peptide, which is co-secreted in an equimolar ratio with insulin. In 1980, R. Philip Eaton from the University of New Mexico assessed prehepatic insulin delivery using peripheral C-peptide concentrations and validated a two-compartment model for C-peptide concentrations (Figure 2) (Eaton 1980). Eaton's work served as a starting point for all major OGTT C-peptide models, including our own (Cretti 2001, Breda 2001, Mari 2002).

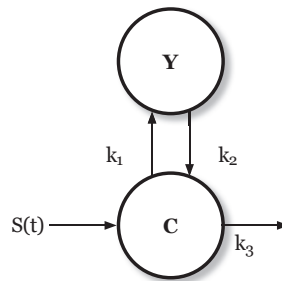

Figure 2. Two-compartment C-peptide model. According to Eaton 1980.

The total intravascular C-peptide pool C is in dynamic equilibrium with the non-accessible total extravascular C-peptide pool Y ; $S(t)$ is the production of C-peptide, i.e. the insulin secretion rate, and k_1 , k_2 and k_3 are fractional turnover rates. Mathematically, the time derivatives of the compartments are:

$$\frac{d}{dt}C(t) = -(k_1 + k_3)C(t) + k_2Y(t) + S(t) \quad (\text{Equation 6})$$

$$\frac{d}{dt}Y(t) = k_1C(t) - k_2Y(t) \quad (\text{Equation 7})$$

By combining the above equations and solving for $S(t)$, a single equation describing C-peptide production can be obtained. While beyond the scope of this thesis, it

deserves to be noted that, thanks to Eve van Cauter et al., $k_1 - k_3$ can be satisfactorily estimated from sex, age, body surface area and information about diabetic status and obesity (van Cauter 1992).

The second basis of glucose/C-peptide models is the non-linear glucose minimal model including hepatic glucose extraction and output (Figure 3) (Bergman 1979).

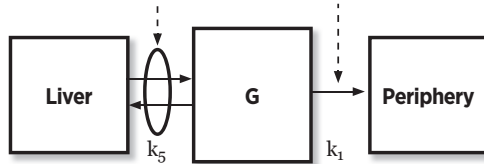

Figure 3. Glucose minimal model including hepatic glucose extraction. According to Bergman 1979.

The third component is the minimal model of insulin secretion (Figure 4) (Bergman 1981).

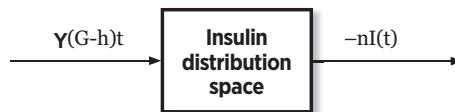

Figure 4. Minimal model of insulin secretion. According to Bergman 1981.

Different approaches have been taken to combine these three submodels. The robust rudiments of these approaches are shown in Figure 5, which displays the minimal model of glucose and C-peptide (insulin) kinetics. The glucose kinetics in the figure are shown in grey to highlight the beta cell model. When glucose or other nutrients are administered orally (*) both the delay and incretin effects must be taken into account.

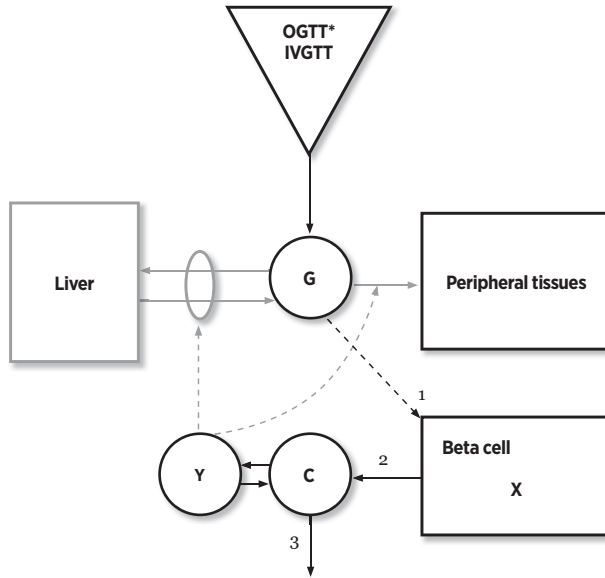

Figure 5. Minimal model of glucose and C-peptide (insulin) kinetics including both oral and intravenous administration routes for glucose. Glucose kinetics are shown in grey to highlight the beta cell model. Adapted from Eaton 1980, Bergman 1979, 1981, Cretti 2001, Breda 2001 and Mari 2002.

In the original, as well as in our model, the influence of glucose on beta cells (arrow 1) is given by a linear term with a rate constant (γ or σ) and a threshold (h or θ) (Bergman 1981, Cretti 2001):

$$\gamma(G(t) - h) \quad \text{(Equation 8)}$$

The provision of new C-peptide (insulin) to be secreted (X) in response to the glucose stimulus (arrow 2) is

$$\gamma(G(t) - h) - nX(t) \quad \text{(Equation 9)}$$

We have used τ^{-1} instead of n (Cretti 2001). The secretion rate, thus, has the same structure as the minimal model ϕ_2 (see Equation 5 above). In our model, the basal C-peptide secretion rate (arrow 3) is estimated to be constant throughout the experiment and related to basal C-peptide concentration, its estimated volume of distribution and body surface area.

Cobelli et al. (Breda 2001) added a dynamic secretory component to the model. It is different from zero only if glucose concentration is between basal (G_b) and threshold (G_t) levels (where threshold G_t is different from threshold h). This adds the first-phase insulin secretion component to OGTT. The equation for the dynamic secretory component according to these authors is:

$$SR_D = K_d \cdot \left(1 - \frac{G(t) - G_b}{G_t - G_b}\right) \cdot \dot{G}(t) \quad (\text{Equation 10})$$

In this equation, K_d is a constant and $\dot{G}(t) = \frac{dG(t)}{d(t)}$.

Mari et al., on the other hand, studied 24-hour glucose and C-peptide profiles in people under free-living conditions (Mari 2001) and modelled the influence of the Staub–Traugott effect, which facilitates glucose disposal following closely spaced successive glucose loads (Staub 1921, Traugott 1922, Abaira 1978). As a result, the original model was supplemented with a “potentiation factor”, which influences the static secretory component. The mathematical form is:

$$S_g(t) = e^{Q(t)} f(G) \quad (\text{Equation 11})$$

In this equation, $e^{Q(t)}$ is the potentiation factor, which varies around a mean value of 1, depending upon the term $Q(t)$, which varies around zero in a piece-wise linear manner over 5 min intervals. Term $f(G)$, representing the static secretory component, has a mathematical expression different from the previous ones (Cretti, Cobelli), but basically expresses a linear relation between glucose and C-peptide (Mari 2002).

An advantage of applying a minimal model to C-peptide (insulin) secretion is that the kinetic and secretion parameters can be solved despite physiological differences between OGTT and IVGTT. This has partly been due to the development of commercially available software designed for compartmental modelling; most of the referred studies have relied on SAAM software (Barrett 1998).

Measurement of pulsatile insulin secretion

In the original study in humans, Lang, Matthews, Turner et al. sampled peripheral plasma insulin every minute for one or two hours and detected frequent 13-min oscillations of plasma insulin with a mean amplitude of 1.6 mU/L (Lang 1979). Polonsky et al. used 28-hour constant or oscillatory glucose infusions with samples taken every 10 min to estimate glucose and C-peptide levels. The concentration values were smoothed using software, followed by identification and temporal analysis of the pulse data (Polonsky 1988). Little progress regarding methodologies has been made since, and there is still no method for reliably and economically detecting and classifying the oscillatory patterns of C-peptide or insulin secretion in larger study samples. Recently, however, commercial software using deconvolution has been released, which can analyse the oscillatory patterns of fasting insulin concentrations. The sampling interval is 30 sec and a study can be performed in just 1 hour (Johnson 2010).

8.1.4 INSULIN ACTION

Insulin has three major target organs. It decreases the hepatic output of glucose (both gluconeogenesis and glycogenolysis) (Bearn 1951, Craig 1961, Pilkis 1986) and it increases glucose uptake in skeletal muscle (Andres 1962) and adipose tissue (Rodbell 1964).

Insulin increases lipid synthesis in liver and fat cells and suppresses the release of fatty acids from triglycerides both in muscle and fat cells. It suppresses protein breakdown in muscle, lipoprotein and triglyceride secretion in the liver and stimulates lipoprotein lipase activity in fat. Figure 6 summarizes the main targets of insulin action (Magkos 2010).

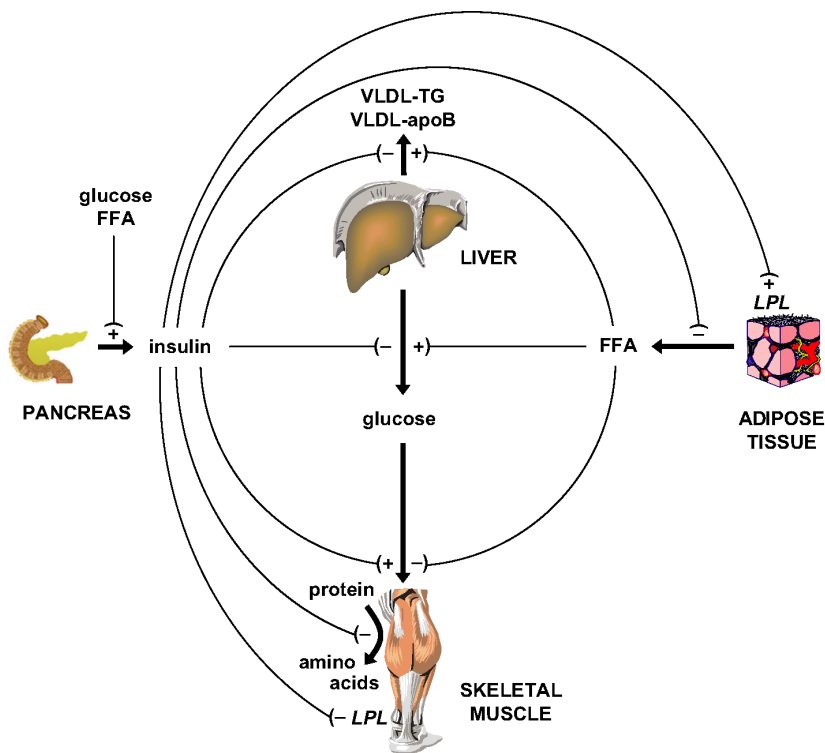

Figure 6. The main targets of insulin action (Magkos 2010). With permission from Elsevier.

Insulin functions by binding to specific receptors, which are abundantly located on the cell surfaces of insulin-sensitive tissues. The extracellular paired alpha-subunits serve as binding sites, from where the signal is transferred to intracellular beta-subunits, three tyrosine kinases of which are subsequently activated (White 1988). In skeletal muscle and in fat cells, the phosphorylation reactions following insulin binding to receptors activate several pathways.

In the present study we have focused on the gluco-regulatory effects of insulin, as measured using the euglycaemic hyperinsulinaemic clamp method.

Insulin sensitivity and insulin resistance

Insulin sensitivity and the lack of it, insulin resistance, are among the most studied and debated topics in medicine. Insulin resistance is not only the epicentre of the metabolic disorder type 2 diabetes mellitus but also precedes its onset. It is present in normoglycaemic relatives of patients with diabetes, characterizes the metabolic profile of multiple other disease states and is an independent risk factor for a multitude of cardiovascular disorders as well as for certain cancers.

History of insulin resistance

Sir Harold P Himsforth from University College London studied healthy humans and published a series of pioneering articles about insulin action and insulin resistance in diabetes. In his most prominent work, published in 1936 in the *Lancet*, Himsforth discussed issues that are still at the core of insulin resistance research today. In addition to covering insulin action in peripheral tissues and the role of liver in insulin resistance, he also described a novel form of diabetes, the insulin-insensitive type, currently known as type 2 diabetes mellitus, and estimated it to be more prevalent than the insulin-sensitive type of diabetes, i.e. type 1 diabetes (Himsforth 2011).

As late as 1970, insulin resistance was used to characterize diabetic patients needing large insulin doses. This was noted in the article by Shiao-Wei Shen, Gerald M. Reaven and John M. Farquhar from Stanford University, CA: “The word impedance is used as a synonym for hindrance, insensitivity, or resistance, but it is preferred to the latter to avoid confusion with the special use of resistance in diabetics who have acquired antibodies to exogenous insulin” (Shen 1970). The article, however, heralded the era of modern studies on insulin sensitivity. The term impedance did not become general and the insulin suppression test, although still used today (Liu 2013), lost out to other methods, mainly because of its limited usefulness among very insulin-sensitive and, on the other hand, highly insulin-resistant subjects (Kim 2011).

In an insulin suppression test, the normal insulin concentration is maintained with exogenous insulin and the resulting glucose concentration is measured. In the mid-1970s researchers from the NIH published two studies in which insulin infusion was used to generate hyperinsulinaemia and plasma glucose was maintained at normal levels with a variable glucose infusion (Sherwin 1974, Insel

1975). The primary aim of Sherwin, Insel, Andres, Tobin et al. was to describe the compartmentalization of insulin into pools with different equilibrium velocities. Their most eminent accomplishment was, however, that they developed the euglycaemic hyperinsulinaemic clamp technique (DeFronzo 1979). In addition to steady-state techniques like the clamp test, there are several methods where insulin sensitivity is estimated from non-steady-state data, the minimal model FSIVGTT being the best known (Bergman 1979).

The first association studies comparing fasting insulin concentration and anthropometric measures were published soon after Yalow and Berson had introduced the insulin RIA (Karam 1963). During the 1970s and 1980s several studies confirmed the association of fasting hyperinsulinaemia with insulin resistance, obesity, dyslipidaemia, impaired glucose tolerance and non-insulin-dependent diabetes (Joffe 1975, Berglund 1976, Stout 1977, Pyörälä 1979, Garcia-Webb 1983, Haffner 1986, Eriksson 1989). Terms like insulin resistance syndrome, metabolic syndrome, multimetabolic syndrome and syndrome X all referred to the clustering of risk factors for type 2 diabetes and cardiovascular diseases. These risk factors included dyslipidaemia, impaired insulin action on glucose metabolism, glucose intolerance, hyperinsulinaemia, obesity, central obesity and hypertension. The concept of insulin resistance was promoted in research meetings of the late 1980s (DeFronzo 1988, Reaven 1988). Despite deviating views, for instance about insulin's role as a cardiovascular risk factor (Jarrett 1992), by the early 1990s insulin resistance had been solidified as one of the central concepts of modern medicine.

Definition of insulin resistance

Insulin resistance is not a disease, merely a physiological state. Identification of insulin resistance is important for the treatment of the disorders it glues together (Reaven 2005). Over the past 30 years, the list of disturbances associated with insulin resistance or included as components of insulin resistance syndrome has continuously expanded (Nolan 2011). Different classifications of insulin resistance syndrome are shown in Table 4.

Table 4. Varying criteria used for the definition of insulin resistance syndrome.

Trait	WHO 1999 (Alberti 1998)	EGIR 1999 (Balkau 1999)	ATPIII (* 2001)	IDF 2005 (Alberti 2005)
Type 2 diabetes	Primary criterion			Type 2 diabetes or fasting hyperglycaemia
Impaired glucose tolerance	Primary criterion			
Insulin resistance or hyperinsulinaemia	Primary criterion	Primary criterion		
Fasting hyperglycaemia		Fasting plasma glucose ≥ 6.1 mmol·l ⁻¹	Fasting plasma glucose ≥ 6.1 mmol·l ⁻¹	Fasting plasma glucose ≥ 5.6 mmol·l ⁻¹
Central obesity	WHR > 0.9 M WHR > 0.85 F	Waist ≥ 94 cm M Waist ≥ 80 cm F	Waist ≥ 102 cm M Waist ≥ 88 cm F	Primary criterion with ethnic and gender specific cut points for waist
Obesity	BMI ² > 30 kgm ⁻²			
Hypertriglyceridemia	Triglycerides ≥ 1.7 mmol·l ⁻¹	Triglycerides > 2.0 mmol·l ⁻¹	Triglycerides ≥ 1.7 mmol·l ⁻¹	Triglycerides ≥ 1.7 mmol·l ⁻¹ or specific treatment
Low HDL cholesterol	HDL ≤ 0.9 mmol·l ⁻¹ M HDL ≤ 1.0 mmol·l ⁻¹ F	HDL < 1.0 mmol·l ⁻¹	HDL < 1.03 mmol·l ⁻¹ M HDL < 1.29 mmol·l ⁻¹ F	HDL < 1.03 mmol·l ⁻¹ M HDL < 1.29 mmol·l ⁻¹ F or specific treatment
Hypertension	BP $\geq 140/90$ mmHg or medication	BP $\geq 140/90$ mmHg or medication	BP $\geq 135/85$ mmHg or medication	Systolic ≥ 130 mmHg or Diastolic ≥ 85 mmHg or medication
Microalbuminuria	Albumin excretion rate ≥ 20 μ g·min ⁻¹ or albumin : creatine ratio ≥ 30 mg·g ⁻¹			
Number of secondary criteria needed	Two or more	Two or more	Three or more	Two or more

* Reference: Expert Panel on Detection, Evaluation, and Treatment of High Blood Cholesterol in Adults

Genetics of insulin resistance

When the current study was initiated, practically all published twin study h^2 estimates of insulin sensitivity or resistance were based on fasting insulin and glucose concentrations (Hong 1997, Narkiewicz 1997, Mayer 1996, Snieder 1999). The fasting insulin and glucose-based h^2 estimates varied between 0.20 and 0.54. The heritability for insulin sensitivity among Pima Indian families using euglycaemic hyperinsulinaemic clamp tests ranged from 0.38 to 0.49, depending upon the level of hyperinsulinaemia (Sakul 1997). With FSIVGTT and the minimal model, the h^2 for the insulin sensitivity index (S_I) was 0.38 for all, and 0.29 for family members with normal glucose tolerance among European sib pairs from families with type 2 diabetes (Elbein 1999). Likewise, the h^2 for S_I among Finnish families with type 2 diabetes was 0.28 (Watanabe 1999).

Until the development of DNA chip technology, only a couple of genes associated with insulin resistance had been identified. The most prominent, and practically the only one that was replicated by several independent research groups, was the peroxisome proliferator-associated receptor gamma gene, PPARG (Greene 1995), identified by us using a parent–offspring design (Altshuler 2000).

Although the majority of new loci suggested by the first two waves of GWASs were associated with insulin secretion, some interesting gene regions associated with insulin action were found as well. An allele of an SNP close to the ADAMTS9 (a disintegrin and metalloproteinase with thrombospondin type 1 motif 9) gene, included in the DIAGRAM Consortium meta-analysis (Zeggini 2008), was shown to be associated with decreased insulin sensitivity of peripheral tissues (Boesgaard 2009). The third and fourth waves of GWASs added to the list, among other genes, insulin receptor substrate 1 (IRS1) (Rung 2009, Sun 1991), glucokinase regulator (GCKR) (Dupuis 2010, Warner 1995) and glucokinase (GCK) (Dupuis 2010), which was originally linked to type 2 diabetes in 1992 (Hattersley 1992).

Assessment of insulin sensitivity or insulin resistance

The focus here is restricted to methods for quantitating insulin sensitivity or insulin resistance of glucose metabolism. In an excellent review of whole body glucose metabolism, Kenneth Zierler, developer of the forearm technique, subdivided glucose uptake estimation methods into those based on measurement of single organ input-output differences and those based on whole body steady-state estimations, and regarded the rest, including all compartmental models, as representations of “lumped” models (Zierler 1999). I chose, however, to classify insulin sensitivity assessment methods as: (1) fasting values and indices built around them, (2) non-steady-state methods and (3) steady-state methods, where there is a progression in the requirements of the techniques.

In general, all estimations of insulin sensitivity are performed after an overnight (10–16 h) fast after the study subjects have been on a weight-maintaining diet for 3 to 7 days. The basic weight-maintaining diet is expected to include at least 250 g, or 5 g/kg weight, of carbohydrates. The most common macronutrient composition used before metabolic studies has been described as 50–60% carbohydrates, 20–30% fat and 15–20% protein.

Fasting values and indices

Fasting insulin concentration

The correlation of fasting insulin with insulin sensitivity was 0.58 among first-degree relatives of type 2 diabetes patients in the Botnia Study, Finland (Groop 1996), 0.61 among healthy volunteers in Stanford, CA, USA (Yeni-Komshian 2000) and 0.81 among diet-treated type 2 diabetes patients in Oxford, UK (Matthews 1985). Skeletal muscle insulin sensitivity, however, explains only part (at most 30%) of the variance of fasting insulin levels. When insulin-stimulated glucose uptake and fasting insulin concentrations from 1,308 subjects in the EGIR (European Group for the study of Insulin Resistance) database were compared, the overlap of insulin resistance criteria using both methods was only 60% (Ferrannini 2002). As the authors wrote: “The explanation for this finding lies in the fact that insulin resistance is only one of the determinants of FPI. Systemic plasma insulin concentrations are the result of β -cell release and plasma removal of the hormone. Other known positive modulators of the fasting insulin secretory rate are the fasting plasma glucose concentration and the degree of obesity.”

Homeostasis model assessment of insulin resistance, HOMA-IR (HOMA-R) index

By studying the relation between fasting plasma glucose and insulin concentrations in 65 newly diagnosed non-complicated diabetes patients, Robert Turner developed a single-compartment model based on a feedback loop between the liver and beta cells. The model can be used to estimate the degree of individual insulin resistance and beta cell defect (Turner 1979). A simplification of the model, HOMA-IR, was later shown to reflect satisfactorily insulin resistance measured using more sophisticated methods, both among healthy and diabetic subjects (Matthews 1985). Due to the modest amount of sampling and analytics needed, HOMA indices became widely used in epidemiological and genetic studies. HOMA-IR is calculated from fasting plasma glucose and insulin concentrations as:

$$\text{HOMA-IR} = \frac{\text{insulin}}{22.5 \cdot e^{-\ln(\text{glucose})}} = \text{insulin} \cdot \frac{\text{glucose}}{22.5} \quad (\text{Equation 12})$$

There are two caveats with HOMA-IR. In the original work by Matthews, the HOMA-IR equation was reserved for normal weight, young subjects with a hypothetical 100% of their insulin secretory capacity. Second, the major contributors to fasting insulin and glucose concentrations are the pancreas and liver, not skeletal muscle. This was, in fact, clearly stated by Turner in the original work (Turner 1979). Among others, we have confirmed this by comparing HOMA-IR with clamp glucose uptake in 467 subjects with varying degrees of glucose tolerance (Tripathy 2004).

The quantitative insulin sensitivity check index QUICKI

Developed and published by Arie Katz et al. from NIH in Bethesda, MD, and the University of Indiana, USA, QUICKI stands for the quantitative insulin sensitivity check index. The equation is analogous to HOMA-IR in that it is based upon fasting glucose and insulin values (Katz 2000):

$$\text{QUICKI} = \frac{1}{\log(\text{insulin}) + \log(\text{glucose})} \quad (\text{Equation 13})$$

In the original study, the authors found QUICKI to be as representative, if not better, a measure of insulin sensitivity as HOMA-IR, when benchmarked against hyperinsulinaemic euglycaemic clamp and FSIVGTT (Katz 2000). However, both QUICKI and HOMA-IR solely use fasting glucose and insulin concentrations and they only differ from each other in the constants used.

Non-steady-state methods

Oral glucose tolerance test (OGTT)

Details of the OGTT method are given in Section 8.1.3. OGTT-derived indices used for the estimation of insulin sensitivity include indexes by Matsuda, Stumvoll, Belfiore, Cederholm, Gutt and Soonthornpun.

Matsuda (Matsuda–DeFronzo) index

This index was developed by Masafumi Matsuda and Ralph DeFronzo from the University of Texas (Matsuda 1999). While incorporating both fasting and mean glucose and insulin concentrations without the need for modelling, the Matsuda index (or insulin sensitivity index) has been widely applied to estimate insulin sensitivity from OGTT data:

$$\text{ISI} = \frac{10000}{\sqrt{((\text{fasting glucose} \cdot \text{fasting insulin}) \cdot (\text{mean glucose} \cdot \text{mean insulin}))}} \quad (\text{Equation 14})$$

The correlation between ISI and glucose uptake measured using euglycaemic hyperinsulinaemic clamp tests was 0.73 in the original study (Matsuda 1999) and similar associations have been observed in other research as well (Lorenzo 2010, Henderson 2011).

Stumvoll index

Michael Stumvoll from the University of Tübingen, Germany, with a collaborative group from five universities in Europe and USA, performed a multiple regression analysis, where OGTT insulin and glucose values were used as independent

parameters and clamp and anthropometric data as dependent parameters (Stumvoll 2000). The authors later returned to their data, and presented, in a letter to *Diabetes Care*, a series of equations with a reduced set of time points, with and without information on BMI (Stumvoll 2001). The original index relates the clamp metabolic clearance rate of glucose (MCR) with information from OGTT and BMI as follows:

$$\text{MCR} = 18.8 - 0.271 \cdot \text{BMI} - 0.0052 \cdot \text{insulin}_{120\text{min}} - 0.27 \cdot \text{glucose}_{90\text{min}}$$

(Equation 15)

Although appealing, the equation is based on data from only 104 Caucasian subjects.

Belfiore index

Francesco Belfiore et al. from the University of Catania, Italy, combined two insulin sensitivity indices, one calculated using OGTT insulin and glucose values and the other using insulin and FFA values (Belfiore 1998). The equations are as follows:

$$\text{ISI}(\text{gly}) = \frac{2}{\text{INS}_p \cdot \text{GLY}_p} + 1$$

(Equation 16)

$$\text{ISI}(\text{ffa}) = \frac{2}{\text{INS}_p \cdot \text{FFA}_p} + 1$$

(Equation 17)

where ISI(gly) is the insulin sensitivity based on insulin-corrected glycaemia level and ISI(ffa) is insulin sensitivity based on the insulin-corrected FFA level. INS_p is the population mean-corrected OGTT insulin area, GLY_p is the OGTT glucose area and FFA_p the OGTT FFA area. The areas can be calculated using a minimum of two OGTT time points (e.g. 0 and 2 hours). The authors emphasized the clinical applicability of the indices, compared to gold standard methods like euglycaemic hyperinsulinaemic clamp testing. They also recommended that each clinical centre should estimate the local population's reference values. In comparison with other indices, the ones by Belfiore have produced equivalent results as glucose uptake measured using clamp testing (Soonthornpun 2003).

Cederholm index

Like the Belfiore index, the one by Jan Cederholm and Lars Wibell from the University of Uppsala, Sweden, can be applied to OGTTs where only fasting and 2-hour samples are available (Cederholm 1985). There are two forms of the index:

$$M = \frac{\text{glucose load}}{120} + (\text{glucose}_0 - \text{glucose}_{2\text{h}}) \cdot 1.15 \cdot 180 \cdot 0.19 \cdot \frac{\text{weight}}{120}$$

(Equation 18)

$$M = 625 + (\text{glucose}_0 - \text{glucose}_{2h}) \cdot 0.19 \cdot \text{weight} \cdot A \quad (\text{Equation 19})$$

where M is the metabolized glucose and the glucose load is the amount of oral glucose. The constants are: 1.15 is to transform whole blood values to plasma values, 180 is to transform glucose mmol to mg values, 0.19 is to convert the volume of the glucose compartment from the body weight and 120 is convert to values per minute. Equation 19 applies when standard 75 g OGTT is used. Constant A depends on glucose measurement and on the units used. A specific feature, and also limitation, of the Cederholm index is that it does not include any insulin parameters at all.

Gutt index

An insulin sensitivity index developed by Miriam Gutt et al. in 2000 is another example that uses only a fasting OGTT and 2-hour concentrations (Gutt 2000). The equation for the Gutt index, $ISI_{0,120}$, is in practice a Cederholm index normalized for both mean glucose and $\log(\text{insulin})$:

$$ISI_{0,120} = \frac{\text{MCR}}{\log \text{MSI}} = \frac{m/\text{MPG}}{\log \text{MSI}} \quad (\text{Equation 20})$$

where

$$m = \frac{(75000 \text{ mg} + (\text{glucose}_0 - \text{glucose}_{2h}) \cdot 0.19 \cdot \text{weight})}{120} \quad (\text{Equation 21})$$

The index uses misleading terminology. The glucose uptake by peripheral tissues is denoted with m , the lowercase probably chosen to distinguish it from the M -value (see the section on euglycaemic hyperinsulinaemic clamp testing below). MCR, the metabolic clearance of glucose, is, analogously to clamp testing, calculated as m/MPG (where MPG is the average of fasting and 2-hour glucose concentrations). This is then normalized by $\log(\text{MSI})$ (where MSI is the average of the fasting and 2-hour insulin concentrations), which bears, finally, no analogy to clamp studies: studies on glucose uptake normalized for both mean glucose and insulin concentrations are not available.

Soonthornpun index

Like the Gutt index, the index developed by Supamai Soonthornpun, from the Prince of Songkla University, Thailand, imitates the clamp approach by taking into account the loss of glucose to urine and by correcting glucose disposal for insulin levels and for the glucose distribution volume (Soonthornpun 2003). The plasma samples are taken every 30 min for 3 hours after a conventional 75 g oral glucose load. The index is calculated using:

$$\text{ISI}_{\text{OGTT}} = \left[\left(\frac{1.9}{6} \text{weight} \cdot \text{fgluc} \right) + \left(520 \cdot \frac{1.9}{18} \text{weight} \cdot \text{AUC}_{\text{gluc}} \right) - \left(\frac{U_{\text{gluc}}}{1.8} \right) \right] \cdot \frac{1000}{(\text{AUC}_{\text{ins}} - \text{weight})}$$

(Equation 22)

where fgluc is the fasting glucose, AUC_{gluc} is the OGTT glucose area, U_{gluc} is the urinary loss of glucose during OGTT and AUC_{ins} is the OGTT insulin area. The derivation of the equation in the original article is scarcely documented and it is based major simplifications and assumptions. These include the proportion of the glucose load estimated to be absorbed by the intestine as well as the use of $0.19 \times$ weight in the calculation of glucose space.

Intravenous glucose tolerance test (IVGTT) and frequently sampled IVGTT (FSIVGTT)

Details of the IVGTT method are given in Section 8.1.3. Stefan Jörgensen and Tage Plum from Copenhagen used an intravenous glucose infusion (“grape sugar”) in the early 1920s to characterize individuals with different degrees of glycosuria (Jörgensen 1923). Twenty years later, a method developed by Eugene Lozner from Harvard Medical School included most elements of modern IVGTTs, excluding the insulin part (Lozner 1941). In 1962 Knud Lundbaek from the University of Århus described how a measure for glucose tolerance, the k-value, could be calculated from the half-life of the declining glucose concentration (Lundbaek 1962).

Measures of glucose disappearance: k-value or K_g

Originally presented by Lundbaek in 1962, the k-value is based on a one-compartment model and represents the glucose disappearance rate after an intravenous glucose bolus (Lundbaek 1962). It is calculated as:

$$k = \frac{\ln \text{glucose}_1 - \ln(0.5 \cdot \text{glucose}_1)}{T_{1/2}} = \frac{\ln 2}{T_{1/2}} = \frac{0.693}{T_{1/2}}$$

(Equation 23)

where $T_{1/2}$ is the time for $\ln(\text{glucose})$ to halve and glucose_1 is the initial concentration. The usefulness of the k-value as a proxy for insulin sensitivity is weak, as it merely reflects the combined influences of peripheral glucose disappearance and hepatic output (Alvarsson 2005).

Minimal model assessment of insulin sensitivity

The following includes the basic modelling used for the calculation of insulin sensitivity indices as presented in the original publications (Bergman 1979, Cobelli 1986). The two-compartment model used for determining insulin and glucose kinetics is shown in Figure 7.

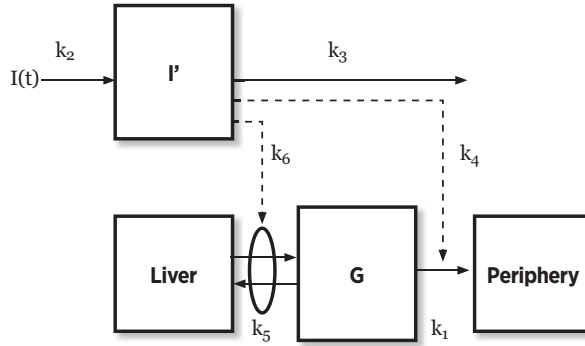

Figure 7. Two-compartment model for insulin secretion and insulin sensitivity in the minimal model. According to Bergman 1979.

$$\frac{d(G)}{d(t)} = (p_1 - X)G + p_4 \quad (\text{Equation 24})$$

$$\frac{d(X)}{d(t)} = p_2X + p_3I(t) \quad (\text{Equation 25})$$

The first equation (24) shows the change of glucose (G) as a function of time (t). On the right side of the equation, p_1 is the total peripheral glucose flux, which is a sum of the measured glucose concentration and glucose incorporated into liver glycogen: $p_1 = -(k_1 + k_5)$. The extrapolated hepatic glucose output at basal glucose concentration can also be expressed as, $p_4 = p_1G_b$ where G_b is the basal plasma glucose concentration. Therefore:

$$\frac{d(G)}{d(t)} = (p_1 - X)G + (p_1G_b) \quad (\text{Equation 26})$$

The second equation (25) shows the change of insulin (X) in the remote (non-measurable) compartment (I) as a function of time (t). In the equation, p_2 is the flux of insulin out of the compartment and p_3 is the influence that the insulin flux k_2 to the compartment has on the glucose fluxes k_1 and k_5 (via k_4 and k_6). $I(t)$ is the time course of (measurable) plasma insulin concentration.

The insulin sensitivity indices obtained from FSIVGTT are:

S_I – insulin sensitivity index: Expresses the fractional glucose disappearance per unit of insulin. Obtained by solving the ratio $-\frac{p_3}{p_2}$ from Equations 25 and 26.

S_G – glucose effectiveness: Expresses the quantitative enhancement of glucose disappearance due to an increase in the plasma glucose concentration. Obtained by solving p_1 from the same Equations 25 and 26.

The developers of the forearm technique, Kenneth Zierler and Reubin Andres, who also helped to develop the euglycaemic clamp test, later questioned the utility of S_G by demonstrating that, in the absence of hyperinsulinaemia, hyperglycaemia per se does not increase forearm glucose uptake (Zierler 2002).

Other non-steady-state methods

Insulin tolerance test (ITT)

The insulin tolerance test, which follows glucose concentrations after a standardized intravenous dose of insulin, is one of the oldest methods for assessing insulin sensitivity. Cyril Macbryde from Washington University in St Louis, USA, described it in 1936 and was probably the first to describe to do so. His aim was to identify those diabetic patients who became glucose intolerant under a high carbohydrate diet (Macbryde 1936). The method was soon applied not only to studies of insulin sensitivity in diabetics (Klatskin 1938) but of counter regulatory hormonal responses to hypoglycaemia (Mirsky 1950). The version known as the short insulin tolerance test, shortened to ITT, was described decades later (Akinmoku 1992).

In practice: After an overnight fast, an intravenous bolus of 0.05–0.1 units per kg weight of short-acting insulin is administered. Arterialized venous plasma samples are collected before and after the bolus every minute for 15 min.

The glucose disappearance rate (kITT or KITT) is calculated either from the log-transformed glucose concentrations between 3 min and 15 min (Bonora 1989) or by dividing $\ln(2)$ (i.e. 0.693) with the time it takes log glucose concentrations to halve, the same procedure that Lundbaek applied to IVGTT (Lundbaek 1962). Concerns about safety (hypoglycaemia) and reproducibility have prompted discussions about and limited the usability of ITT (Chen 1998, Alberti 1999).

Himsworth test

In the test developed by Sir Harold Himsworth, an intravenous insulin bolus is followed immediately by an oral glucose dose and blood glucose is measured at frequent intervals for 90 min. The test is used to differentiate insulin-sensitive and insensitive diabetes patients.

In practice: An intravenous bolus of short-acting insulin (5 units per m^2 body surface area) is followed by ingestion of glucose (30 g per m^2 body surface area) dissolved in $\frac{1}{2}$ pint of water. Blood samples are taken at the basal state and then every 10 min for 60 min, then at 75 and 90 min.

Himsworth used dual sampling from peripheral veins and ear lobe capillaries to get an estimate of the capillary (arterial)–venous difference. Although interpretation of test results is more observatory than quantitative, Himsworth was able to differentiate insulin-sensitive from insensitive subjects by comparing their test glucose profiles. The time course of the capillary–venous differences further supported the observations (Himsworth 2011, Kim 2011).

If the insulin tolerance test is straightforward, representing “an American approach” to metabolic questions, then the Himsworth test was typically European: it was intricate, included several questions and as many answers. Besides Himsworth himself, the test has been mentioned in only a few publications, the last one probably being by Tan, Gerich et al. in 1980 (Tan 1980).

Meal test

Although meal tests have long been used to study glucose tolerance (Mellinkoff 1956), most of the study protocols have been ad hoc. No meal test protocol was available to estimate insulin action until in 2000 Claudio Cobelli et al. from the University of Padua published a meal glucose tolerance test (MGTT) with a minimal model approach for glucose disappearance (Caumo 2000). The approach is principally identical to the minimal model described above, with oral glucose or mixed meal input appended to the glucose time course equation in the following way:

$$\frac{d(G)}{d(t)} = (p_1 - X)G + p_1 G_b + \frac{r_\alpha(t)}{V} \quad (\text{Equation 27})$$

$$\frac{d(X)}{d(t)} = p_2 X + p_3 I(t) \quad (\text{Equation 25})$$

where r_α is the per unit body weight rate of entry of exogenous glucose into the system as a function of time and V is the distribution volume. Insulin sensitivity is expressed as p_3/p_2 , as usual (Caumo 2000). The approach was later improved, using C-peptide instead of insulin measurements, to account for insulin secretion and hepatic insulin extraction as well (Cobelli 2007).

Steady-state methods

Euglycaemic hyperinsulinaemic clamp

The version of the euglycaemic hyperinsulinaemic clamp test published by Ralph DeFronzo, Jordan Tobin and Reuben Andres in 1979 has remained practically unchanged over 30 years. It is the gold standard method for estimating insulin-stimulated glucose uptake (DeFronzo 1979).

In the test, hyperinsulinaemia is induced and a chosen plasma glucose level is maintained using intravenous insulin and glucose infusions. The amount of glucose infused to maintain glycaemia reflects the whole body glucose uptake and, hence, characterizes the insulin sensitivity of the subject.

In practice: A priming stepwise-decreasing infusion of short-acting insulin (100 IU/ml) is given intravenously and followed by a steady infusion for the rest of the

study. Plasma glucose is analysed at the bedside at 5 min intervals. Euglycaemia is maintained with a variable intravenous infusion of 20% glucose. In our studies, plasma glucose has been kept at $5.5 \text{ mmol}\cdot\text{l}^{-1}$ and the insulin dose calculated as $45 \text{ mU per min} \cdot \text{m}^2$ of body surface area. Mean glucose and insulin concentrations from the last 60 min of the 120 min protocol have been used to calculate steady-state parameters (Tripathy 2004). Glucose uptake (glucose that is “metabolized”, hence letter M) is calculated from the glucose infusion rate during the steady-state period and expressed as an M-value ($\text{mg per min} \cdot \text{kg}$ of fat-free mass), and often also as a steady-state plasma insulin concentration (M/I).

An advantage of the clamp technique is that several components can be varied: insulin dose, clamp glucose level, study duration as well as accessory protocols for the clamp. In the original study by Sherwin, two insulin doses were used: $1 \text{ mU per kg weight}$ (corresponding to 40 mU per m^2) and 2 mU per kg (Sherwin 1974). Much higher doses of insulin, up to $4,000 \text{ mU per m}^2$, resulting in plasma insulin concentrations of $20,000 \mu\text{U/ml}$, have been used especially in very insulin-resistant individuals (Bonadonna 1990). Sherwin et al. defined euglycaemia as the basal blood glucose concentration of the study subject, varying over $4.7\text{--}5.6 \text{ mmol}\cdot\text{l}^{-1}$ ($85\text{--}100 \text{ mg}\cdot\text{dl}^{-1}$) (Sherwin 1974). Today, steady-state glucose concentrations of $4.0\text{--}5.5 \text{ mmol}\cdot\text{l}^{-1}$ are called either euglycaemic or isoglycaemic: in euglycaemic individuals the clamp state may be called isoglycaemic, and in hyperglycaemic individuals euglycaemic (Riccardo Bonadonna, personal communication 18 December 2012).

Hyperglycaemic clamp test

Details of the hyperglycaemic clamp technique can be found in Section 8.1.3. In hyperglycaemic clamp testing the M-value is the amount of glucose infused per unit weight or per fat-free mass, corrected for the amount of glucose lost in urine (DeFronzo 1979). Even the authors of the original paper admitted that the estimate of glucose uptake obtained via the hyperglycaemic clamp technique is more or less a measure of intravenous glucose tolerance where the glucose concentration, not the amount infused, is fixed.

Continuous infusion of glucose with model assessment (CIGMA)

Robert Turner presented CIGMA (Hosker 1985) back to back with HOMA (Matthews 1985) as a short and easily manageable test of both insulin action and secretion. It consists of a 60-min constant intravenous low-dose infusion of glucose ($5 \text{ mg per kg ideal body weight}$) with only three venous blood samples at 50, 55 and 60 min. Insulin resistance R and beta cell function β are simply estimated by reading the values from a predetermined grid with plasma glucose (a mean of three measured values) on the x -axis and insulin on the y -axis. Turner designed the grid by fitting empirical data into a model with separate one-compartment models for both glucose and insulin concentrations.

Insulin suppression test

In the test developed by Shiao-Wei Shen, Gerald Reaven and John Farquhar from Stanford University, endogenous insulin secretion is suppressed with a propranolol-adrenalin infusion. Exogenous insulin is infused at a constant rate and glucose uptake is quantified from the amount of infused glucose needed to maintain a steady plasma glucose concentration. The higher the glucose concentration during the steady state, the more insulin resistant the subject (Shen 1970). The interrelationship between glucose uptake and glucose infusion during the steady state is expressed as:

$$V = k_u G \quad (\text{Equation 28})$$

where V is the glucose uptake in mg per kg body weight, G is the (steady-state) plasma glucose concentration and k_u is a diffusion constant. The impedance, that is the resistance to insulin action, is

$$\frac{1}{k_u} \quad (\text{Equation 29})$$

In a modification of the test by Yukio Harano, the propranolol-adrenalin infusion was substituted by somatostatin (Harano 1977). KGMM Alberti used somatostatin to suppress endogenous insulin secretion in 1973 (Alberti 1973). This was later modified for the somatostatin version of the insulin suppression test (Heine 1985).

Limb balance techniques

The method developed by Reubin Andres, Gordon Cader and Kenneth Zierler from Johns Hopkins University (Andres 1956) is still in use today (Vicini 1998, Zierler 2002). It requires cannulation of both the brachial artery and a deep forearm vein and exclusion of blood flow distal to the wrist. An indicator dye is used for the simultaneous measurement of blood flow (F) through the forearm. The method is based upon the Fick principle: the rate of substrate use is proportional to the product of flow and difference between output and input (Andres 1956). The rate of glucose metabolized per unit of forearm (limb) mass can thus be expressed as:

$$\dot{Q}_M = \frac{a}{b} \cdot \frac{F_T \cdot (A - V_M)}{M_T} \quad (\text{Equation 30})$$

where F_T is the total forearm flow, A is the glucose concentration in the artery, V_M is the deep vein glucose concentration, M_T is the total forearm mass, a is the

fraction of the total flow perfusing muscle and b is the fraction of muscle mass in the forearm (Andres 1956).

History: The effect of insulin on arterio-venous (A-V) difference in glucose concentration was studied soon after the discovery of insulin (Cori 1928). Himsworth used the capillary-venous difference in his glucose tolerance test (Himsworth 2011). In 1950 Michael Somogyi from St Louis Jewish Hospital described the influence of subcutaneous epinephrine on the glucose A-V difference (Somogyi 1950) and the fundamentals of the modern limb balance technique were described 6 years later by Andres (Andres 1956), who, more than 6 years later, also characterized insulin action on forearm glucose uptake (Andres 1962). In 1990, Alain Baron with post-doctoral student Markku Laakso from Indianapolis University used the forearm technique to estimate leg glucose uptake in obese individuals (Laakso 1990).

Combined methods

Although a combination of hyperglycaemic and euglycaemic clamp techniques would represent the gold standard for assessing insulin secretion and action, they are so time-consuming and invasive that they must be performed on separate days. Therefore, there is a need for cost-effective and simple measurements of insulin secretion and action during a single study session.

Botnia clamp technique

The Botnia clamp technique is a combination of an IVGTT (samples at 0, 2, 4, 6, 8, 10, 20, 30 and 40 min) followed by a conventional 2-hour, 45 mU per min · m² hyperinsulinaemic euglycaemic clamp, which begins after 60 min (Tripathy 2003). It yields the conventional first-phase insulin response to intravenous glucose (dose 0.3 g·kg⁻¹), calculated as the incremental rise in insulin concentration during the first 10 min, as well as a second-phase insulin response, calculated as the incremental rise in insulin concentration between 10 and 60 min. Glucose uptake is measured from the glucose infusion rate during the last 60 min of the clamp. As insulin secretion and insulin sensitivity are measured during a single test, a disposition index can be estimated as the product of the first-phase insulin secretion and glucose uptake (Tripathy 2003).

FSIVGTT and minimal model

FSIVGTT and the minimal model have been described in Section 8.1.3 and earlier in the current section.

Glucagon-stimulated C-peptide test and insulin-tolerance test (GITT)

Compared to the Botnia clamp test and FSIVGTT, a shorter method was recently proposed by Mozghan Dorkhan from Malmö University Hospital (Dorkhan 2008). A low-dose glucagon bolus is administered (0.5 mg) followed 30 min later by a low-dose insulin bolus (0.05 IU per kg of short-acting human insulin). C-peptide and glucose levels are sampled at 0, 6, 30, 31, 33, 35, 37, 39, 41, 43, 45, 50 and 60 min. The incremental C-peptide level at 6 min is used as a beta cell response to glucagon and the slope of the regression line of the glucose concentration after insulin bolus at 30 min is used for the calculation of insulin sensitivity, expressed as a K-value or KITT. The authors show that, unlike IVGTT and hyperglycaemic clamp testing, GITT can also be used for subjects with type 2 diabetes, whose impaired beta cell function influences both the assessment of insulin secretion and insulin sensitivity.

Meal test

The meal test has been described under steady-state methods.

8.1.5 REPRODUCIBILITY OF ASSESSMENT METHODS

Goodarzi et al. demonstrated recently, that fasting insulin concentration in Mexican Americans was influenced by several factors including BMI, glucose uptake, insulin clearance, fasting glucose and waist circumference (Goodarzi 2011). The authors warranted that interpretation of insulin action and secretion measures based on fasting insulin should, therefore, be done with caution. In general, the coefficient of variation (CV) for fasting insulin and related indices has varied between 7.8 and 19.0 %, respectively (Bonora 2000, Tripathy 2003). The interindividual variation of clamp FSIVGTT have varied from study to study, with CV's for the former ranging between 14.4% (Ferrari 1991) and 20.2% (Steil 1994), and for the latter between 9.0% (Tripathy 2003) and 38% (Morris 1997), respectively. The intra-individual CV for the first phase insulin (FPI) secretion, calculated as the incremental area under insulin curve during the first 10 min of an IVGTT, has varied between 6.0% (McNair 1995) and 27% (Tripathy 2003), respectively.

8.2 METHODOLOGY FOR THE STUDY OF VARIABILITY AMONG INDIVIDUALS

8.2.1 HISTORY OF QUANTITATIVE GENETICS

Augustinian priest Gregor Johann Mendel (1822–1884) from Brno, in what now is the Czech Republic, was the first to study the ratio of different trait variants in consecutive generations. He wrote: “Pea hybrids form germinal and pollen cells that in their composition correspond in equal numbers to all the constant forms resulting from the combination of traits united through fertilization” (Stern 1966). This incorporates the principles now known as Mendel’s laws of segregation and independent assortment. Mendel did not receive recognition from his colleagues and almost 35 years passed until 1900, when three scientists, DeVries, Correns and Tschermak, independently replicated Mendel’s results and credited him for the original work (Roberts 1929).

The mathematical modelling of inheritance is based upon the work of Sir Francis Galton (1822–1911), a half-cousin of Darwin. He published 340 works and introduced the concepts of regression and correlation for studying continuous variation in humans (Galton 1889). Galton’s work was developed by his co-worker Karl Pearson (1857–1936). Pearson showed that what Galton meant by regression, designated by the letter r , was actually (Pearson’s) correlation (Magnello 2004). In 1901 Galton, Pearson and Walter Weldon (1860–1906) founded the scientific journal *Biometrika*, which published articles about the biometrical theory of inheritance. They postulated that both near and distant relatives contributed to heredity and that trait variation in a population was continuous. This was fiercely opposed by the Mendelians, who claimed that distinct hereditary units must yield discontinuous variation (Rushton 2000). The Mendelians were led by an embryologist from St Johns College, Cambridge, William Bateson (1861–1925), who in 1905 coined the term genetics, and in 1908 became the world’s first professor of Genetics, at Cambridge University. Bateson worked with Hugo de Vries, the first scientist to use the term mutation (de Vries 1902).

The debate between the biometricians and the Mendelians came to end only when a British statistician, Ronald A. Fisher (1890–1962), credited as probably the most influential statistician of the 20th century, solved the discrepancies in a groundbreaking article “The correlation between relatives on the supposition of Mendelian inheritance” (Fisher 1918). During his almost 50-year career Fisher introduced several statistical methods and concepts, including the distribution of correlation coefficient, maximum likelihood, analysis of variance and (Fisher) information (Fienberg 1980). His book *The Genetical Theory of Natural Selection* (Edwards 2000), which Fisher dictated and his wife wrote down, is regarded as one of the most important scientific publications since Darwin’s *On the Origin*

of Species (Fisher 1999). It was a comprehensive synthesis of Darwin's theory of evolution and natural selection and Mendel's theory of heredity, tied together using biometrical statistics. Fisher, Sewall Wright (1889–1988) and John B.S. (Jack) Haldane (1892–1964) are regarded as the founders of theoretical population genetics. Wright introduced concepts like the inbreeding coefficient, genetic drift and path analysis (Wright 1921, 1931, 1934).

Genetic epidemiology would not exist in its present form without the contributions of a German physician, geneticist and twin-study pioneer, Wilhelm Weinberg (1862–1937), and a British mathematician, Godfrey H. Hardy (1877–1947). Weinberg, owing to his clinical work in helping those who could not afford proper health care, had already become acknowledged for his studies on cancer and had been developing a differential method for determining the frequencies in twinning (Mayo 2008). In January 1908 he presented a paper where he derived the general equilibrium principle for a single locus with two alleles (Provine 1971). In February 1908, Bateson's co-worker in Cambridge, zoologist Reginald C. Punnett (1875–1967), was asked after a lecture in London why recessive phenotypes were not removed from the population. Punnett was not able to answer satisfactorily, and turned to his friend in Cambridge, G.H. Hardy, who answered (with "a little mathematics of the multiplication-table type") that "if the parental genotypic proportions were $p AA : 2q Aa : r aa$, then they would be $(p + q)^2 : 2(p + q)(q + r) : (q + r)^2$ among the offspring" (Edwards 2008). As *Nature* was at that time a hostile publishing environment for Mendelians, Hardy published his result in the July 1908 issue of the journal *Science* (Hardy 1908). The multiplication table for the calculation of genotypic proportion, the "checkerboard", has since the 1950s been named Punnett's square (Davis 1993).

The development of quantitative genetics speeded up when Fisher brought geneticist Kenneth Mather (1911–1990) as a lecturer to University College, London, in 1934. In collaboration with his student John L. Jinks (1929–1987), in 1971 Mather wrote the book *Biometrical Genetics* (Mather 1982), the first version of which Mather had written on his own in 1949 (Mather 1949). While the model-fitting developed by Mather and Jinks was applicable to plants, David W. Fulker (1937–1998), a student of Jinks, applied biometrical models to human behavioural genetics (Jinks 1970). Norton E. Morton from the University of Hawaii implemented path analysis in biometrical modelling (Morton 1974, 1974a, 1974b, Rao 1974, 1974a, MacLean 1975). Norton's work was followed by three publications from John Rice, Robert Cloninger and Theodore Reich from Washington University (Rice 1978, Cloninger 1979a, 1979b), where they described a general linear model of familial resemblance, allowing for cultural transmission from parent to offspring, polygenic inheritance, phenotypic assortative mating, common environment, maternal and paternal effects, threshold effects and genic-cultural correlation. When, Nicholas Martin and Lindon Eaves from the University of Birmingham published their work in 1977, in which

the analysis of covariance structures was adapted to the simultaneous maximum likelihood estimation of genetical and environmental factor loading and specific variances (Martin 1977), the methodology in genetic epidemiology for studying resemblance between relatives had practically been laid out.

Karl Jöreskog, then in Princeton, NJ, working on covariance structures, produced the first computer algorithms for parameter estimation and hypothesis-testing (Jöreskog 1973). The collaboration between Jöreskog (1972) and Dag Sörbom at the University of Uppsala, Sweden, led to the development of the computer program LISREL (linear structural relations; <http://www.ssicentral.com/lisrel/references.html>), which went through several versions and became the most used tool for structural equation modelling (SEM) during the 1970s and 1980s. In 1990, based partly upon his experience in using and teaching LISREL, Michael Neale from Virginia Commonwealth University, together with Steve Boker, began to develop the Mx software, which among other features provided a graphical user interface for drawing path diagrams prior to the statistical processing of the models (Neale 1992, 2004). Mx became the most used SEM program during the 1990s, and since then it has become the core of OpenMx, open-source software for estimating a wide variety of advanced multivariate statistical models (<http://openmx.psyc.virginia.edu>) (Boker 2011).

8.2.2 TWIN STUDIES

The credit of the first scientific publication to use twin data is usually given to Sir Francis Galton (Galton 1875) although he recommends the paper *Die Lehre von den Zwillingen* by Dr Ludwig Kleinwächter (Kleinwächter 1871). Possibly the first twin study where the twins were tested was conducted by Edward Thorndike in 1905 (Thorndike 1905). A systematic presentation of what is now known as the classical twin method, was in 1924 described independently by Hermann Werner Siemens (Siemens 1924) and Curtis Merriman (Merriman 1924). The same year, the first Norwegian female professor, Kristine Bonnevie, studied fingerprint patterns using twin pair data, and proposed them to be a result of polygenic influences (Bonnevie 1924).

The first large twin study was performed and published as a monograph by Horatio Newman, Frank Freeman and Karl Holzinger from the University of Chicago (Newman 1937). The twins were followed for 10 years, their physical measures recorded, parents interviewed and an array of psychological characteristics estimated. The statistical methods included analysis of concordance and discordance, and the estimation of heritability with analysis of variance (ANOVA), as developed by Holzinger. The ANOVA method was the prevailing one until the introduction of structural modelling during the 1970s. In addition to the main study, which included

50 identical (MZ) and 50 fraternal (DZ) twin pairs, Newman also published, in a series of articles in the *Journal of Heredity* between 1929 and 1940, the first study of 19 twin pairs reared apart (Newman 1937).

In Finland, psychologist Arvo Lehtovaara from the University of Jyväskylä published the first twin studies in 1938 in the form of a doctoral thesis. He studied psychological and behavioural traits of 144 twin pairs between the ages of 3 months and 17 years (Lehtovaara 1938). The Finnish Foundation for Alcohol Studies funded a study between 1958 and 1960, consisting of all male twin pairs ($n = 1050$) born between 1920 and 1929. A series of publications followed, including also the first Finnish twin studies on blood glucose and serum cholesterol (Sammalisto 1961, Pikkarainen 1964a, 1964b, Kumento 1965, Partanen 1966, Pikkarainen 1966, Kulonen 1967, Frey 1968). The latter studies were performed independently before the launch of the Finnish Twin Cohort Study in 1974 (Sarna 1976, Koskenvuo 1976, Sarna 1978, Kaprio 1978), of which the current thesis is part.

8.2.3 HERITABILITY

The detailed theory of the genetic epidemiology used in this study is available in several textbooks (Falconer 1996, Khoury 1993, Neale 2004) and only a couple of conceptual issues will be covered here.

The study of familial resemblance in genetic epidemiology aims at answering questions about the degree and causes of similarities and differences between parents and their children and between children within families (Khoury 1993). Genetic epidemiology asks: How important are genetic effects on human differences? What kind of actions and interactions occur between gene products in the pathways between genotype and phenotype? Are the genetic effects on a trait consistent across sexes? It does not, on the other hand, try to give answers to questions about which genes cause what or where in the genome they might be found (Neale 2004).

The use of the terminology in the current study follows that presented by John Fuller and William Thompson in their textbook of behavioural genetics (Fuller 1979): phenotypes are observable characteristics, genotypes are the chromosomal complements of gene alleles. Genes are the unit factors of inheritance influencing observable traits. Alleles are maternal or paternal forms of genes in the same locus on a chromosome. The Hardy–Weinberg equilibrium (HWE) holds, that is, allele and genotypic frequencies remain unchanged in an (infinitely) large population where migration and mutation are not acting and other selective forces do not exist (Stern 1943). In theory, random mating is also assumed, though recent studies show that certain types of non-random mating allow the HWE to be maintained (Li 1988), or that random mating is merely an extreme case of non-random mating (Stark 2006). The preconditions used for the structural equation modelling are: the genes

and environmental effects are independent, environmental effects are independent across individuals and the polygenic effect is due to many independent additive genetic effects each of small size.

Definition of the statistics of similarity

Table 5 lists the explanations and equations for the most common twin statistics, which also are the basic interactions used in the path models. The core statistic of twin data is covariance, which is a measure of how values for each twin pair differ from the respective population (sample) means. Correlation is the covariance corrected with the standard deviation. Variance is a special covariance as it is the covariance of a variable with itself.

Table 5. Basic statistics used in the quantitation of similarity between relatives.

Statistic, symbol	Definition	Equation number
Mean, \bar{x}	Arithmetic mean of a distribution	
	$\frac{(x_1 + x_2 + x_3 + \dots + x_n)}{n}$	Equation 31
Variance, s^2 or V_{MZ} or V_{DZ}	Variability of a trait, a measure of the spread of individual values	
	$\frac{[(x_1 - \bar{x})^2 + (x_2 - \bar{x})^2 + (x_3 - \bar{x})^2 + \dots + (x_n - \bar{x})^2]}{n - 1}$	Equation 32
Covariance, $s_{x,y}$ or Cov_{MZ} or Cov_{DZ}	A measure of how much sets of variables change together	
	$\frac{[(x_1 - \bar{x}) \cdot (y_1 - \bar{y}) + (x_2 - \bar{x}) \cdot (y_2 - \bar{y}) + \dots + (x_n - \bar{x}) \cdot (y_n - \bar{y})]}{n - 1}$	Equation 33
Correlation, r	Covariance, normalized by the deviation of observations from the mean	
	$\frac{s_{x,y}}{\sqrt{(s_x^2 \cdot s_y^2)}}$	Equation 34
Standard deviation, SD	Square root of variance	
	$\sqrt{\left(\frac{[(x_1 - \bar{x})^2 + (x_2 - \bar{x})^2 + (x_3 - \bar{x})^2 + \dots + (x_n - \bar{x})^2]}{n - 1}\right)}$	Equation 35

Genotypes and population frequencies

In a randomly mating population under HWE, the genotypic effect is thought to be a measurable property that is dependent on the gene dose, i.e. the presence of 0, 1 or 2 dominant alleles in a gene locus plus additive or dominant effects that deviate the heterozygote genotypic effect from the midpoint between the two homozygotes. A schematic representation is shown in Figure 8.

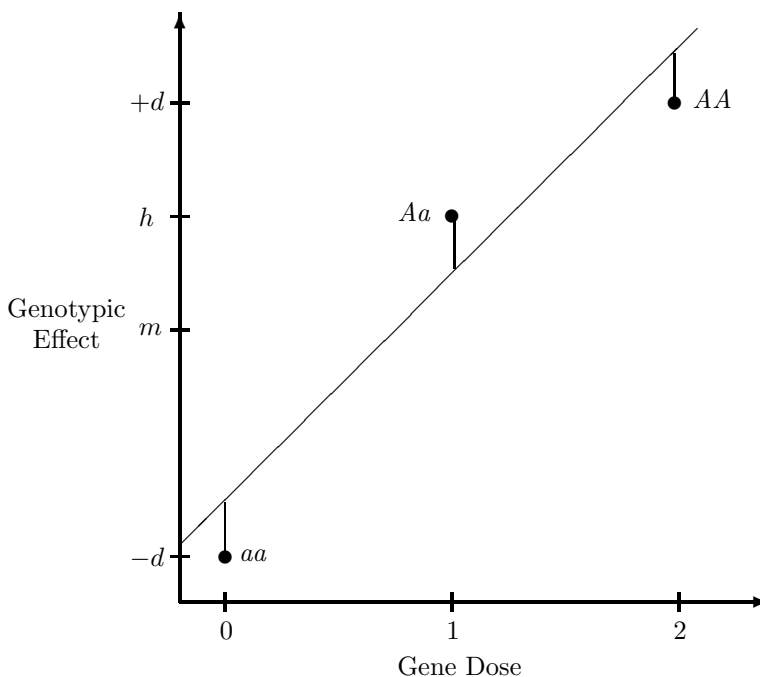

Figure 8. Graphical representation of the relations between gene dose of homozygotes and heterozygotes and the genotypic effect in a one-locus model with two alleles (Neale 2004). With permission from Springer Netherlands.

Consider a one-locus, two-allele model with genotypes AA , Aa and aa , respectively. The homozygotes (AA , aa) cause, on the population level, a deviation from the trait mean m . The heterozygote (Aa) causes a deviation h ($h > m$ or $h < m$). In case where $h \neq m$, it is assumed that the alleles A and a have unequal effects on the trait. This is called dominance. The dots represent the observed values of the genotypes plotted against the gene dose. The allele A is considered to increase the trait value. A regression line has been fitted using least squares. In HWE, with allele

frequencies u for A , and v for a , for the genotypes AA , Aa and aa , with genotypic effects d , h , $-d$ and gene A doses of 2, 1, 0, the genotypic frequencies are u^2 , $2vu$ and v^2 , respectively.

Decomposition of variances

In short, under the preconditions listed above, SEM is based on the following: MZ twins share all their genes and gene combinations. On average, DZ twins as well as full sibs share half, half sibs a quarter and parents and offspring half of their genes and gene combinations, respectively. Unrelated siblings (children with different biological parents but raised by common parents) do not share genetic influences.

1. The shared environment is assumed to be similar between all siblings reared together.
2. The variance of a trait can be partitioned to latent genetic and environmental effects.
3. The genetic variance can further be partitioned to additive variance, variance due to dominance and variance due to epistasis, i.e. the interaction of loci over different alleles:

$$V_G = V_A + V_D + V_I \quad \text{(Equation 36)}$$

4. The variance due to environmental influences can be partitioned into variance shared between family members, variance due to repetitive measures and unique environmental influences including error:

$$V_C + V_R + V_E \quad \text{(Equation 37)}$$

5. In case gene-environment covariation and gene-environment interaction are also included, the total phenotypic variance of a trait, V_p , can, thus, be decomposed as to:

$$V_P = V_A + V_D + V_I + V_C + V_R + V_E + 2V_{G,E} + V_{G \times E}^2 \quad \text{(Equation 38)}$$

6. The covariance between two family members is:

$$\text{Cov}(Y_1, Y_2) = 2 \cdot \Phi_{ij} \cdot V_G \quad \text{(Equation 39)}$$

where the term Φ_{ij} is the theoretical kinship coefficient.

In most twin studies V_P , V_R and covariance and interaction between genes and environment cannot be estimated (Visscher 2008).

Table 6. Equations for calculation of covariance between relatives.

Covariance between relatives both using allele frequencies and genotypic effects (I) and variance components (II)			
Cov _{MZ}	I	$2uv[d + (v - u)h]^2 + 4u^2v^2h^2$	Equation 40
	II	$V_A + V_D$	Equation 41
Cov _{DZ}	I	$uv[d + (v - u)h]^2 + u^2v^2h^2$	Equation 42
	II	$\frac{1}{2}V_A + \frac{1}{4}V_D$	Equation 43
Cov _{unrelated siblings}	I	0	Equation 44
	II	0	Equation 45
Cov _{half sibs}	I	$\frac{1}{2}uv[d + (v - u)h]^2$	Equation 46
	II	$\frac{1}{4}V_A$	Equation 47
Cov _{parent-offspring}	I	$uv[d + (v - u)h]^2$	Equation 48
	II	$\frac{1}{2}V_A$	Equation 49

Bivariate model

With two traits, it is possible to observe variances of the individual traits, correlations and covariances of the same traits between twins as well as the cross-twin cross-trait (ctct) correlations and covariances. Table 7 is an elegant summary by Peter Visscher of the population correlations for MZ and DZ twins in a bivariate model. The correlations are displayed separately for three variance component models: AE, CE and ACE, which represent the partitioning of the total phenotypic variance V_P to either $V_A + V_E$ (AE), $V_C + V_E$ (CE, no genes involved) or $V_A + V_C + V_E$ (ACE).

Table 7. Population correlations in terms of bivariate model parameters for MZ and DZ twins.

Correlation	Model for both x and y			Equation numbers
	AE	CE	ACE	
$r_{x(\text{MZ})} =$	h_x^2	c_x^2	$h_x^2 + c_x^2$	Equations 50–52
$r_{x(\text{DZ})} =$	$\frac{1}{2}h_x^2$	c_x^2	$\frac{1}{2}h_x^2 + c_x^2$	Equations 53–55
$r_{y(\text{MZ})} =$	h_y^2	c_y^2	$h_y^2 + c_y^2$	Equations 56–58
$r_{y(\text{DZ})} =$	$\frac{1}{2}h_y^2$	c_y^2	$\frac{1}{2}h_y^2 + c_y^2$	Equations 59–61
$r_{xy(\text{MZ})} =$	$r_g h_x h_y$	$r_c c_x c_y$	$r_g h_x h_y + r_c c_x c_y$	Equations 62–64
$r_{xy(\text{DZ})} =$	$\frac{1}{2}r_g h_x h_y$	$r_c c_x c_y$	$\frac{1}{2}r_g h_x h_y + r_c c_x c_y$	Equations 65–67
$r_p =$	$r_g h_x h_y + r_e e_x e_y$	$r_c c_x c_y + r_e e_x e_y$	$r_g h_x h_y + r_c c_x c_y + r_e e_x e_y$	Equations 68–70

Published with the permission from Peter Visscher (Visscher 2006).

The variance ratios in the population are denoted h_i^2 , c_i^2 and e_i^2 , for traits $I = x, y$. The covariance ratios are $r_g h_x h_y$, $r_c c_x c_y$, and $r_e e_x e_y$. Hence, r_g , r_c , and r_e are the correlations of the additive genetic effects, common environmental effects and individual environmental effects, respectively. The total variance ratio is equal to one, i.e.

$$h_i^2 + c_i^2 + e_i^2 = 1 \quad (\text{Equation 71})$$

The sum of covariance ratios, i.e. the products of the covariances and correlations of the respective additive genetic, common environmental and unique environmental effects, sum up to r_p , the correlation between x and y in the population, measured for the same individual:

$$r_g h_x h_y + r_c c_x c_y + r_e e_x e_y = r_p \quad (\text{Equation 70})$$

Heritability

Heritability is the proportion of the total variance of a trait that is explained by genetic influences. In the absence of non-additivity, heritability in the narrow sense is written as:

$$h^2 = \frac{V_A}{V_P} \quad (\text{Equation 72})$$

The proportion of the total genotypic variance of the total phenotypic variance is the heritability in the broad sense:

$$H^2 = \frac{V_G}{V_P} \quad (\text{Equation 73})$$

Intraclass correlations and concordances

A simplified approach is to compare MZ and DZ intraclass (intrapair) correlations, where the trait value of twin 1 is correlated to the value of twin 2 within a twin pair. This method is less accurate than the model-fitting procedure, because the correlation coefficient is a function of both covariances and variances (Neale 2004), but lends itself to easier interpretation. In the presence of purely additive genetic variance (besides non-genetic influences from the unique environment):

$$\text{intraclass } r(\text{MZ}) = 2 \cdot \text{intraclass } r(\text{DZ}) \quad (\text{Equation 74})$$

Environmental factors shared by the twins tend to decrease the ratio of $\frac{\text{intraclass } r(\text{MZ})}{\text{intraclass } r(\text{DZ})}$, whereas non-additive genetic factors increase it (Neale 2004).

Table 8. Explanation of other statistics used for quantitation of similarity between twins.

Statistic	Explanation	Equation Equation number
Intraclass correlation	Normalized difference of the squared deviations between pairs MSA = mean-squared deviation among pairs MSW = mean-squared deviation between pairs	$\frac{(MSA - MSW)}{(MSA + MSW)}$ Equation 75
Concordance, pairwise	Conditional probability that both members of a twin pair are affected if at least one of the members is	$\frac{N_{\text{concordant}}}{(N_{\text{concordant}} + N_{\text{discordant}})}$ Equation 76
Concordance, casewise	Conditional probability that a twin is affected if the co-twin is	$\frac{2N_{\text{concordant}}}{(2N_{\text{concordant}} + N_{\text{discordant}})}$ Equation 77

8.2.4 STATISTICAL METHODS

Regression (simple, multiple or logistic) is used to determine whether a variable or variables predict a variable of interest. At its simplest, the regression equation is in the form of a straight line, i.e.

$$y = \alpha + \beta x + e \tag{Equation 78}$$

where y is the dependent variable, x is the independent variable, α is the intercept, β is the regression coefficient and e is an error term (residuals). In the least-squares method, α and β are calculated by solving β by summing over the squares of all deviations of the observed data from the predicted line and finding α from:

$$\bar{y} = \alpha - \beta \bar{x} \tag{Equation 79}$$

In ordinary least squares, the squared deviations are summed with equal weights. In weighted least squares, different weights are assigned to each deviation (e.g. zero for outliers). Multiple regression analysis is an extension of the simple regression where y is predicted by several independent x_i each with unique β_i .

Structural equation modelling and path analysis

Path diagrams are a graphical way to display relations between manifest variables (measured traits), latent influencing (genetic and environmental) factors, the “strength” of paths between them as well as the similarity between relatives. They

are used to describe theoretical structures (i.e. models) and fit models to real data using an array of statistical approaches. Figure 9 is a typical univariate (one-variable) model where a phenotypic trait P of twin pair members P_1 and P_2 is shown with the latent additive (A), dominance (D), shared environmental (C) and unique environmental (error) (E) variance components.

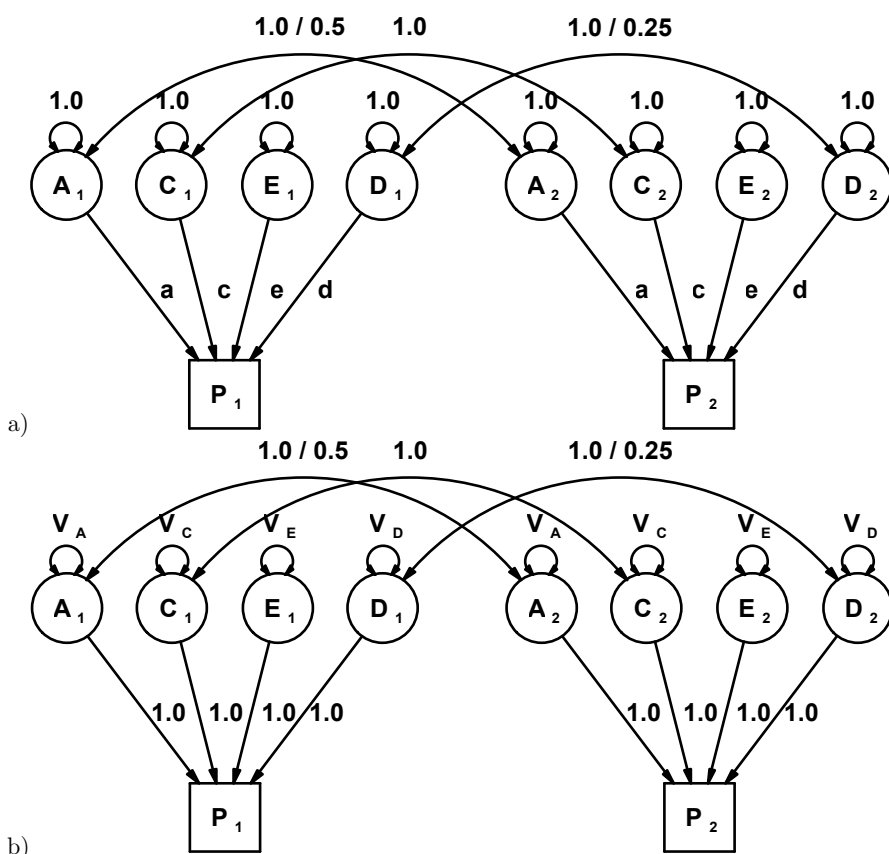

Figure 9. Example of a univariate (one-variable) model with a phenotypic trait P of twin pair members P_1 and P_2 and with the latent variance components. In panel a) the variances are fixed to 1.0 and the path coefficients are calculated. In b) the variance components will be estimated from data (Neale 2004). With permission from Springer Netherlands.

The covariances between twins 1 and 2 have a value 1.0 for both A and D for MZ twins, and 0.5 and 0.25, respectively, for DZ twins. In SEM, the chi-squared goodness-of-fit statistics are used to assess how well a model fits the data. The relative goodness of fit of different models can be tested using the likelihood ratio

test, which is based on the more general model (like AE) being nested in a detailed model (for example ADE). Comparing the AE and ADE models gives the following likelihood ratio:

$$LR = \chi^2(AE) \pm \chi^2(ADE) \quad (\text{Equation 80})$$

with degrees of freedom:

$$df = df(AE) \pm df(ADE) \quad (\text{Equation 81})$$

If the new chi-squared χ^2 , thus obtained, i.e. the likelihood ratio, is significant at $p = 0.05$, this means that there is deterioration in the fit of the model when the extra variable, D in the example, is fixed at zero (Neale 2004).

8.3 GENETICS OF COMPLEX DISORDERS

As estimation of heritability from twin and family data comes under quantitative epidemiology. The molecular genetics of complex disorders are only briefly mentioned here.

The major successes in genetics have been for rare monogenic disorders, the number of which now exceeds 5,000. In approximately half of these, a mutation has been identified (Gilissen 2012). Most common conditions, like diabetes and obesity, are, however, complex and do not follow a single-gene dominant or recessive pattern of inheritance (Smith 2003).

Regardless of the mode of inheritance, the basic genetic approach has in outline remained the same: identify the trait or disease, decide how to approach its genetic variance component, collect biological samples, isolate the DNA, get the phenotype information and try to associate a chromosomal region, a gene locus or a causative variant for the trait or disease phenotype in question. Some designs used commonly only a few years ago are rarely used now, but are described below for the sake of completeness.

If a trait seems to follow Mendelian inheritance, the commonest way to explore its genetics is to ascertain pedigrees, identify phenotypes and search for a linkage between a genetic marker and the affected phenotype. The underlying assumption is that affected pedigree members in a generation are identical by descent (IBD): they have all inherited the genotype causing the trait from the same ancestor.

Before recombinant DNA technologies, the only available genetic markers were blood groups and human leukocyte (HLA) antigens. In fact, in genetic studies blood was collected from family members, centrifuged and the buffy coat containing the DNA was discarded (Hinrichs 2011). Today, polymorphic

DNA regions are used as markers. Polymorphism implies that the base pair variability is sufficient to segregate individual differences. The early markers were restriction fragment polymorphisms (RFLPs), which were followed by simple sequence-length polymorphisms (SSLPs) and microsatellites (Gilissen 2012). The most commonly used markers today are single-nucleotide polymorphisms (SNPs). They are densely present throughout the genome and stable compared to microsatellite markers and, because of their binary nature, can be used for automated high-throughput genotyping (Sachidanandam 2001).

Only approximately one-fourth of diseases follow Mendelian inheritance and the rest have more or less complex genetics (Jin 2012). According to Lander and Schork, “The term complex trait refers to any phenotype that does not exhibit classic Mendelian recessive or dominant inheritance attributable to a single gene locus. In general, complexities arise when the simple correspondence between genotype and phenotype breaks down, either because the same genotype can result in different phenotypes (due to the effects of chance, environment, or interactions with other genes) or different genotypes can result in the same phenotype” (Lander 1994). An interesting additional observation by Jin et al. was that 13% of diseases had both Mendelian and complex modes of inheritance and that 54% of the Mendelian genes were also associated with complex disorders (Jin 2012). This has also been seen for diabetes, where common variants of the genes that cause MODY are associated with common type 2 diabetes.

A fundamental reason for the complexity is the nature of disease diagnosis, which is very often based on signs and symptoms (as is common in psychiatric conditions), extremes of normal physiology (such as diabetes, obesity and hypertension) that carry an elevated risk of clinical complications or descriptions of abnormal findings in medical imaging or organs (many pathology diagnoses). All of these share the characteristic that the causal agent or mechanism is rarely known. As disease variants become identified for cases, those that remain are “idiopathic or essential” cases of unknown cause.

Several features complicate the identification of non-Mendelian disease genes. These include incomplete penetrance, phenocopies, heterogeneity, polygenic inheritance including additive effects and epistatic interactions, high frequency alleles and other genetic mechanisms of inheritance. A variety of methods have been used to overcome these difficulties. The affected sib-pair method, originally described in 1935 (Penrose 1935), has been widely used, especially for disorders with a large gene effect (Suarez 1978). The sib-pair approach has more power when there is information not only of affected sibs, who are identical by state (IBS), but also of their parents. Weeks and Lange developed the affected pedigree member method by substituting IBS relations with information about generalized IBD relations (Weeks 1988).

Linkage-based studies rely only on information about allele segregation for a trait or disease. Association studies ask, on the other hand, whether an allele of a gene (related to a protein) assumed to be involved in the disease process, is more prevalent among cases than controls. Finding genetically matched cases and controls is often challenging in case–control studies. This has led to the use of internal controls, like the untransmitted allele of the parents of an affected sib in the transmission disequilibrium test (TDT) and haplotype relative risk test (HRR) (Spielman 1996).

In 1996 Risch and Merikangas showed that an association scan using one million genetic variants dispersed throughout the genome would be more powerful than a linkage using hundreds of markers (Risch 1996). That became reality ten years later, and genome-wide association studies have since 2007 been the main method for studying complex diseases. According to the National Institutes of Health, a GWAS is defined as “any study of genetic variation across the entire human genome that is designed to identify genetic associations with observable traits (such as blood pressure or weight), or the presence or absence of a disease or condition”. In addition, to meet the definition of a GWAS, the density of genetic markers and the extent of linkage disequilibrium should be sufficient to capture a large proportion of the common variation in the genome of the population under study, and the number of samples (in a case–control or trio design) should provide sufficient power to detect variants of modest effect (Anon 2007).

An optimal set-up for a GWAS includes well-defined quantitative or dichotomous phenotypes, and an ethnically homogeneous study population. These criteria must often be compromised: the trait is classified as either present or absent (affected versus unaffected), populations must be pooled and the allele frequencies therefore corrected for population stratification (Bush 2012).

Complex disorder genetics is based upon how genomes at the population level change over time. The shorter the distance between two alleles in a chromosome, the more likely it is that they are passed together in meiosis, a condition called linkage disequilibrium (LD). Linkage disequilibrium measures the fragmentation of the genome at the population level. Fragmentation increases generation after generation and populations move from LD towards linkage equilibrium (Lange 1993).

A gene search attempts to identify alleles in LD with disease genes. Alleles, including SNPs, segregate as haplotypes, i.e. knowing a “tag” SNP enables identification of the rest. The International Haplotype Map Project (HapMap) was set up in 2002 to identify groups of SNPs that are highly correlated (designated as having a high r^2) throughout the genome for different ethnic populations (Anon 2005). According to HapMap, a sufficient coverage (over 80%) of the genome can be attained using 550,000–1,100,000 SNPs with a minor allele frequency (MAF) of at least 5% (Frazer 2007). The basis for setting the MAF limit to 5% has been not only economical and practical but also theoretical. According to the common disease, common variant hypothesis (CDCV), common gene alleles dispersed throughout the

genome are responsible, each via a small effect and in undefined ways, for the risk for common diseases (Lander 1996). The CDCV hypothesis has been challenged as it has become clear that Mendelian disease genes are involved in common diseases and that a significant gap exists between population-based complex disease h^2 values and the observed h^2 values based on GWAS (Jin 2012).

The increase in the power and cost-effectiveness of nucleotide research techniques has occurred in parallel with the increasing number of identified SNPs. The development of DNA arrays with 0.5 to 1 million oligonucleotides on a thumb-sized computer-compatible microchip has enabled real genome-wide association studies, and the first results came in 2007 (DiStefano 2011). By 2013, more than 9,000 GWAS reports had been published, with each year surpassing the previous one (Hindorff 2013).

A major change in methodologies took place in 2008, when laboratories shifted from automated Sanger-sequencing techniques to next-generation sequencing (NGS) (Metzker 2010). Although comparing results from the different commercial NGS platforms is demanding, the speed and unit cost of sequencing have improved drastically over the last five years. To sequence a genome in 2007 cost approximately 10 million USD. In 2012 the same procedure cost less than 10,000 USD and the aim is to reach 1,000 USD per genome (Wetterstrand 2013). Despite the progress, whole genome sequencing (WGS) still is resource intensive and targeted sequencing strategies have been favoured. The most common of these is whole exome sequencing (WES), which analyses only protein-coding regions. Exomes comprise approximately 2% of the human genome and WES costs on average a tenth of what is needed for WGS (Myllykangas 2013). In addition, the huge amount of data poses huge challenges for bioinformatics and obtaining and storing detailed individual genetic information raises ethical questions. However, the main challenge is to understand the NGS results. This was formulated by the Human Genome Variation Society in a meeting report from 2013: “The ability to create this information has been noted, but the ability to understand the effect of a genetic variant on disease, or disease predisposition, is still in its infancy” (Ellard 2013).

9. AIMS OF THE STUDY

1. To study the extent to which insulin action and insulin secretion, as measured with gold standard methods, are affected by genetic factors for middle-aged twins without diabetes.
2. To estimate the heritability, that is the proportion of the risk for type 2 diabetes due to genetic factors, by using generation-long follow-up data from a population-based twin cohort study.
3. To compare the twin-study based heritability estimates with those obtained from a large collection of families with type 2 diabetes mellitus.

10. MATERIALS AND METHODS

10.1 STUDY SUBJECTS

10.1.1 THE FINNISH TWIN COHORT STUDY

The twins participating in the current study comprise the so-called older cohort of the Finnish Twin Cohort Study, which is attempting to identify the genetic and environmental determinants of chronic diseases and their risk factors (Kaprio 1978, 2002). A baseline questionnaire was given in 1975 to twin pairs of the same gender born before 1958, and the individual response rate was 89%. Twin zygosity was determined in 1975 from the responses of the members of each pair to two questions on the similarity of their appearance at primary school age. A set of decision rules was used to classify 93.1% of the twin pairs as MZ or DZ, while 6.9% remained undetermined. A validation study using genetic markers showed that this questionnaire method is highly accurate (Sarna 1978).

10.1.2 THE BOTNIA STUDY

The Botnia Study was originally initiated in 1990 in four primary care centres (Narpes, Malax-Korsnas, Korsholm and Jakobstad) in Western Finland near the Gulf of Botnia. Swedish and Finnish incomers, whose descendants remained in this mixed rural and urban area, settled the region about 1,000 years ago. The prevalence of diabetes is about 3%. About 85% of patients have type 2 diabetes (Eriksson 1992) and the initial treatment was diet alone or oral anti-diabetic agents for at least 6 months. All 1,164 patients with known type 2 diabetes from the centres were invited to participate in the study. The response rate was 95% and patients with type 2 diabetes who had at least two living first-degree family members (parents, siblings or children) were selected for further study. All first-degree family members were invited to participate in the study; 76% of them ($n = 2,152$) were examined within the first two years. There was an average of 2.8 persons in each of the 732 families. Most of the non-respondents were emigrants living in Sweden or in the US. A total of 528 randomly chosen spouses without a family history of diabetes served as control subjects.

10.1.3 DATA COMPILATION

Studies I to III

Twin pairs resident in Helsinki and the surrounding communities, with no diabetes according to earlier questionnaires, were randomly selected from the Twin Cohort and invited to participate in the studies. All subjects underwent an OGTT (plasma glucose and serum insulin at 0 and 120 min). Altogether 210 twin pairs were identified and the response rate was about 74%. The study protocols have been reviewed and approved by the local ethics committee. Informed written consent was obtained from all subjects before their participation. Some pairs were excluded because they were taking anti-diabetic drugs ($n = 4$) or because of unclear zygosity ($n = 1$). The final study sample consisted of 151 twin pairs. Of these 302 individuals, there were 24 (9 MZ), 54 (23 MZ) and 14 (6 MZ) subjects with impaired fasting glycaemia (IFG), impaired glucose tolerance (IGT) and diabetes, respectively, following WHO criteria (WHO 1999). Among these, there were 1 DZ pair concordant for IFG, 1 MZ and 4 DZ pairs concordant for IGT and a single MZ pair concordant for type 2 diabetes.

Study IV

Data on the incidence of type 2 diabetes mellitus in twins between 1976 and 1987 was first collected through linking computerized records, using the unique personal ID assigned to all Finns, from death certificates, the National Hospital Discharge Register and the Medication Register of the Social Insurance Institution. The results were published in 1992 (Kaprio 1992). The same information resources were used to gather information on new cases of diabetes between 1988 and 1995 for the same cohort of twins. This data was examined by two research physicians using the same classification of diabetes as in the earlier report, who determined a date for the diagnosis. Finally, the Medication Register was used in 2006 to update the information on all medical certificates for diabetes between 1996 and 2004 for the twin cohort. This compilation included only a general diagnosis of diabetes, birth date and the date for certificate admission. As all study subjects were 38 or older in 1996, it was assumed that all of them had type 2 diabetes and that the date of diagnosis was the date of certification. Individuals with diabetes in 1975, based upon a questionnaire or from the registers, were excluded from the analysis. During a follow-up, the vital status was obtained from the Population Register Centre of Finland, including information on deaths, migration and the current address in Finland.

After combining the datasets, there were 32,778 twin individuals (16,507 males and 16,271 females) in the cohort. After removing subjects with diabetes at the

baseline or undefined zygosity (mainly due to non-responses in the questionnaire) or who had moved abroad or died before 1 January 1976, there were 23,585 twin individuals with self-reported BMI available (11,446 men and 12,139 women; 7,374 MZ and 16,211 DZ). Among them, there were 4,076 MZ and 9,109 DZ pairs, respectively. In the analyses, after considering possible confounders, there were 23,238 twins remaining (11,292 males and 11,946 females; 7,269 MZ and 15,969 DZ), as twins with missing covariate data (information on educational level, occupation, social class, leisure time physical activity and alcohol consumption) were removed. In the calculation of concordances, only pairs with both members with complete information available were used (3,327 MZ and 7,182 DZ).

The numbers are summarized in Table 9.

Table 9. Summary of the number of participating twin pairs in studies I to IV.

Numbers of pairs	Study I	Study II			Study III	Study IV
		IVGTT	OGTT	IVGTT & OGTT		
Number of MZ pairs (male/female)	21 (15/6)	21 (15/6)	33 (16/17)	13 (9/4)	66 (28/38)	4,076 (1,911/2,165)
Number of DZ pairs (male/female)	20 (13/7)	20 (13/7)	23 (12/11)	14 (9/5)	85 (33/52)	9,109 (4,570/4,539)

Study V

Family information was obtained for 25,962 individuals from 1,131 families participating in the Botnia Study. For the heritability estimates of quantitative traits and type 2 diabetes, we restricted the analysis to families with phenotype information from at least two members, which resulted in 5,810 individuals from 942 families with an average family size of 6.16. Of these, 1,707 had type 2 diabetes. Diabetes was diagnosed using the WHO 1999 criteria (WHO 1999). Patients with GAD antibodies or known MODY mutations were excluded. The clinical and metabolic characteristics were recorded for all individuals and non-diabetic individuals 16 years or older.

10.2 METHODS

10.2.1 ANTHROPOMETRIC, BODY COMPOSITION AND BLOOD PRESSURE MEASUREMENTS

Height (to the nearest centimetre without shoes) and weight (to the nearest kilogram in light indoor clothing) were recorded. The body mass index (BMI) was calculated as weight/height² (kg·m⁻²). The waist circumference (to the nearest centimetre without clothes) was measured with a non-elastic soft tape midway between the lowest rib and the iliac crest on standing subjects. The hip circumference (to the nearest centimetre without clothes) was measured over the widest part of the gluteal region. The waist-to-hip ratio (WHR) was calculated as a measure of abdominal obesity. The fat-free mass (FFM) and fat mass (percentage) were measured using bioelectrical impedance (Segal 1985, Franssila-Kallunki 1992). In study V, lean body mass was estimated by measuring the absorption of infrared light in subcutaneous tissue (Futrex, Gaithersburg, MD, USA). Systolic (SBP) and diastolic (DBP) blood pressure was measured with a mercury sphygmomanometer (Speidel and Keller, Jungingen, Germany) from the right arm of the subjects after a 15-min rest. The results were expressed as the mean of three consecutive readings for studies I to IV with the patients in a sitting position, and as the mean of two recordings for study V with the patients in a supine position.

In study IV, the twins were asked for their current weight (kg) and height (cm), which were used to assess their BMI (kg·m⁻²) at baseline. The validity of the self-reported BMIs was tested for a subsample of twins (100 men and 125 women) from the same cohort by first asking for their weight and height in a questionnaire in 1990, and then measuring them in 1992–1993. The correlation coefficients between self-reported and measured BMIs in men and women were 0.89 and 0.90, respectively (Korkeila 1998).

10.2.2 ASSESSMENT OF INSULIN SECRETION AND GLUCOSE METABOLISM

A polyethylene cannula was placed in an antecubital vein of the study subjects after an overnight fast and baseline blood samples were drawn to measure fasting plasma glucose, serum insulin and plasma C-peptide concentrations.

OGTT: studies II, III and V

OGTT was used to characterize the glucose tolerance status and to estimate beta cell function. Subjects ingested 75 g glucose solution over 5 min. After 120 min,

blood samples were drawn to measure plasma glucose, serum insulin, and plasma C-peptide (study III) concentrations. A subset of twin pairs underwent OGTT with additional blood sampling at 30, 60 and 90 min (study II). For study V, the blood samples for plasma glucose and serum insulin concentrations were drawn at -5, 0, 30, 60 and 120 min.

IVGTT and clamp tests

In the IVGTT and euglycaemic hyperinsulinaemic clamp tests, the blood was sampled using a polyethylene cannula inserted retrogradely into a dorsal hand or a distal forearm vein. The hand was placed in a heated (70° C) box to arterialize the venous blood (Liu 1992).

IVGTT: studies I and II

IVGTT was used to measure insulin secretion: 0.3 g/kg body weight of glucose (maximum dose 35 g) was infused intravenously for 2 min and arterialized blood samples were drawn at 0, 2, 4, 6, 8,10, 20, 30, 40, 50 and 60 min to measure plasma glucose and serum insulin concentrations.

Clamp tests: studies I and II

The whole-body glucose uptake was quantified with a 160-min euglycaemic hyperinsulinaemic clamp test (DeFronzo 1979, Eriksson 1989): an intravenous primed continuous insulin infusion of 45 mU/min per m² was administered and maintained for 160 min, while euglycaemia was maintained using a variable intravenous infusion of 5% glucose. The plasma glucose level was assessed at the bedside from samples of arterialized blood drawn every 5 min.

Botnia clamp

IVGTT and clamp testing were carried out on separate days for 14 MZ and 5 DZ twin pairs and on the same day for 8 MZ and 15 DZ pairs (Tripathy 2003). When done on the same day, the clamp test was started 30 min after the end of the IVGTT. In these subjects, the glucose uptake was adjusted for the influence of the preceding IVGTT. Overall, a preceding IVGTT resulted in a 7% increase in the glucose uptake during the clamp test. Both members of a twin pair participated in the same protocol.

10.2.3 LABORATORY ASSAYS

Plasma glucose was measured in duplicate with a glucose oxidase method using a Beckman Glucose Analyzer II (Beckman Instruments, Fullerton, CA). Serum insulin concentrations in studies I to IV were measured by RIA (Pharmacia, Uppsala, Sweden) with an interassay CV of 5%, and in study V by an enzyme immunoassay (DAKO, Cambridgeshire, UK) with an interassay CV of 7.5%. Serum C-peptide concentrations were measured by RIA with an interassay CV of 9% (Linco, USA).

10.2.4 CALCULATIONS

Beta cell function

IVGTT: studies I and II

In study I, the first-phase insulin secretion (FPI) was calculated as the incremental area under the insulin curve during the first 10 min and the late-phase insulin secretion (LPI) was calculated as the incremental area under the insulin curve during the last 50 min of the IVGTT. The area under the curve was calculated using the trapezoidal rule. In study II, beta cell secretion during IVGTT was estimated by applying a model of glucose-induced insulin secretion to the glucose and insulin curves of each subject. This model is similar to the one proposed for C-peptide during hyperglycaemic clamp testing (Bonadonna 2003), which was based primarily on the minimal model for C-peptide during IVGTT (Toffolo 1995). It is described in the appendix of study II. Both readily releasable insulin (RRI; $\text{pmol}\cdot\text{l}^{-1}$) quantifying first-phase insulin secretion as well as sigma, that is beta cell sensitivity to glucose during the second phase of insulin secretion ($[\text{pmol}\cdot\text{l}^{-1}\cdot\text{min}^{-1}]$ per $[\text{mmol}\cdot\text{l}^{-1}]$), were estimated by implementing this model of insulin secretion in the commercially available software package SAAM. This package was used to create ordinary differential equations from a compartmental model structure, to simulate complex experimental protocols for the model, to solve the model and to fit it to the data (Barrett 1998).

OGTT: studies II, III and V

In study II, beta cell secretion during OGTT was estimated by applying a model of glucose-induced insulin secretion to the glucose and C-peptide curves of each subject, as previously described by us (Cretti 2001). The model for C-peptide kinetics and secretion was resolved with the aid of the SAAM software package, and in all studies it was used to calculate the OGTT beta index (log units), a compound parameter of beta cell function during OGTT. The parameters for glucose-induced beta cell secretion were estimated to good precision, as shown by the CVs for RRI:

11.7 ± 0.9%; sigma: 28.8 ± 1.7% and the OGTT beta index: 10.5 ± 1.2%. In study V, the beta cell response to oral glucose was assessed using the insulinogenic index (Equation 3). In studies III and V, beta cell function was also estimated by calculating the HOMA-BETA index (Equation 1).

Insulin sensitivity

Clamp testing: studies I and II

In studies I and II, insulin sensitivity was assessed using the euglycaemic hyperinsulinaemic clamp method by calculating the amount of infused glucose needed to maintain euglycaemia during the last 40 min of the study (120–160 min). The insulin sensitivity was expressed as glucose uptake in mg/min per kg of weight and per kg of FFM. The latter was used in the calculations.

Other indices of insulin sensitivity: studies III and V

The homeostasis model index for insulin resistance (HOMA-IR) (Equation 12) was used in studies III and V. In study V, the insulin sensitivity index (ISI) was also calculated from OGTT as suggested by Matsuda (Equation 14).

10.2.5 STATISTICAL METHODS

Data are expressed as means ± SD. Trait values were transformed to normality as indicated. The data were also analysed separately for female and male twins whenever sex-related effects were detected. The clustering of data, since the study population consisted of twin pairs, was taken into account in the comparison of the MZ and DZ mean values (studies II to IV). Differences between the MZ and DZ twin pairs were tested with a two-tailed *t* test. If not otherwise stated, a *p* value was considered significant if less than 0.05. For study V, asymmetrically distributed variables were log-transformed before analysis, and all quantitative trait analyses were adjusted for age, sex, the interaction between age and sex, age² and affection status (type 2 diabetes). In addition, all traits except BMI were adjusted for BMI. The covariates not found to be significant after covariate screening were removed from the final models.

In study IV, the Cox proportional hazard regression was used to estimate the relative risk of incident type 2 diabetes mellitus by BMI category (underweight: under 18.5 kg·m⁻², normal weight: 18.5 to 24.9 kg·m⁻², overweight: 25 to 29.9 kg·m⁻², obese: 30 to 34.9 kg·m⁻² and morbidly obese: 35 kg·m⁻² and over), by integer values of BMI, as well as per unit BMI and per SD of BMI. For type 2 diabetes cases, the follow-up ended at the date of diagnosis, while other subjects were censored at the

time of death, migration from Finland or end of follow-up (31 December 2004). Regression models were adjusted for age and sex only as well as for additional covariates.

In study V, sibling relative risk (λ_s) was calculated as the risk of diabetes in siblings of patients with type 2 diabetes compared with the background population, following the method proposed by Olson and Cordell (Olson 2000). Differences in Pearson correlation coefficients between parent–son and parent–daughter pairs were evaluated using the corcor function (Goldstein 1996), which is a test for dependent correlation coefficients in Stata (StataCorp 2003).

The statistical packages used are summarized in Table 10.

Twin correlations and variance components in studies I to IV

Standard univariate twin analyses were carried out (Williams 1992), including the test for homogeneity of the mean values and variances across the twin type. Maximum likelihood analyses based on sample covariance matrices were used to estimate the components of variance (Williams 1992, Neale 2004). In a study of twins reared together, it is possible to model four separate components: (A) an additive genetic component, (D) effects due to dominance and (C) shared and (E) non-shared environmental components. One can fit the models based on different combinations of these variables (AE, ACE, ADE and CE) but the effects due to dominance and shared environmental effects cannot be simultaneously modelled with data from twins reared together (Neale 2004). Chi-squared goodness-of-fit statistics were used to assess how well the model fitted the data. The relative goodness of fit of different models was tested using the likelihood ratio (Equations 56 and 57). The simplified alternative comparison of intraclass-correlation coefficients for MZ and DZ pairs was also used (Equation 50).

In study II, a cross-twin cross-trait (ctct) correlation (the correlation of trait 1 values for twin 1 vs. trait 2 values for twin 2, and vice versa) of RRI and sigma was also performed, to see if there was a common genetic factor.

Bivariate analyses were performed to study the degree of correlation of the latent genetic and environmental factors influencing both Ins_0 and Ins_120 (study III) and BMI and type 2 diabetes (study IV). In study III, variance components were estimated by applying the maximum likelihood method to fit the models to the raw data, using age and sex as covariates. In study IV, age-adjusted bivariate genetic factor models were estimated separately for male and female twin pairs, using the mean and variance weighted least-squares method (WLSMV) implemented in the MPlus software system (Prescott 2004). BMI was included as a continuous trait and type 2 diabetes as a dichotomous trait. The bivariate model in study IV yielded, along with the variance components, the coefficients for phenotypic (r), intraclass (IC)

and genetic (r_g) correlations and the correlation between environmental variance components (r_e). The bias-corrected 95% confidence intervals were estimated using a bootstrap method with 1,000 draws.

Heritability of type 2 diabetes and quantitative traits in the Botnia Study, study V

The SOLAR software package provides a maximum likelihood estimate of heritability, taking into account additive genetic effects and residual errors (Almasy 1998). Heritability is the proportion of the phenotypic variance that is due to additive genetic effects after adjustment for covariates. The heritability of type 2 diabetes was estimated using a liability threshold model implemented in SOLAR (Duggirala 1997). In addition to the common covariates (age, sex, age•sex, age•age and BMI), the SNP in TCF7L2, rs7903146, was added as a covariate for the analysis of h^2 of type 2 diabetes.

Table 10. Statistical packages .

Study	Name	Purpose	Reference
IV	MPlus	Twin variance component analysis	www.statmodel.com Prescott 2004
I, II, III	Mx	Twin variance component analysis	www.vcu.edu/mx/ Neale 2004
II	SAAM (Simulation, Analysis And Modeling)	Compartmental model simulation and solving	www.saam.com Barrett 1998
V	SOLAR (Sequential Oligogenic Linkage Analysis Routines)	Genetic variance component analysis	Almasy 1998
I	SOLO	Descriptive statistics, phenotypic correlations	www.ncss.com Lovie 1989
II, III, IV	Stata versions 7 & 8	Descriptive statistics, phenotypic correlations, hazard ratios	www.stata.com StataCorp 2003
I,II,III	Twinan	Twin correlations	Williams 1992

11. RESULTS

Detailed results are given in the original publications and only briefly summarized here.

11.1 CLINICAL CHARACTERISTICS

A summary of the clinical characteristics of twins participating in studies I to IV and the individuals in study V are shown in Tables 11 and 12. The twins in studies I to III were selected from the cohort for study IV. The age and BMI in study IV are from 1975, when the follow-up for that study began. All twins participated in at least two studies. The glucose tolerance of the twins was normal in studies I to IV.

Table 11. Clinical characteristics of MZ and DZ twins.

	Study I	Study II	Study III	Study IV
Number of MZ pairs (female/male)	21 (6/15)	42 (20/22)	66 (38/28)	3,289 (1,782/1,507)
Number of DZ pairs (female/male)	20 (7/13)	28 (12/16)	85 (52/33)	7,090 (3,639/3,451)
Age MZ (years)	61.4 ± 4.3	63.1 ± 4.9	59.8 ± 0.9	35.8 ± 14.7
Age DZ (years)	63.5 ± 2.3	66.5 ± 3.5	59.0 ± 0.8	35.8 ± 14.1
BMI MZ (kg·m ⁻²)	26.2 ± 3.1	26.8 ± 0.5	26.9 ± 0.4	22.6 ± 3.4
BMI DZ (kg·m ⁻²)	26.5 ± 3.0	26.6 ± 0.4	26.9 ± 0.4	22.9 ± 3.3
WHR MZ male	0.94 ± 0.01		0.947 ± 0.009	
WHR DZ male	0.98 ± 0.01		0.959 ± 0.008	
WHR MZ female	0.82 ± 0.01		0.837 ± 0.011	
WHR DZ female	0.85 ± 0.01		0.839 ± 0.010	
Fasting glucose MZ (mmol·l ⁻¹)	5.6 ± 0.1		5.6 ± 0.1	
Fasting glucose DZ (mmol·l ⁻¹)	5.9 ± 0.1		5.7 ± 0.1	
Fasting insulin MZ (pmol·l ⁻¹)	50 ± 4		8 ± 0	
Fasting insulin DZ (pmol·l ⁻¹)	48 ± 3		9 ± 0	
2-hour glucose OGTT MZ (mmol·l ⁻¹)	6.8 ± 0.2		6.7 ± 0.2	
2-hour glucose OGTT DZ (mmol·l ⁻¹)	7.7 ± 0.4		6.7 ± 0.2	
2-hour insulin OGTT MZ (mmol·l ⁻¹)			44 ± 4	
2-hour insulin OGTT DZ (mmol·l ⁻¹)			48 ± 4	

The individuals in study V were patients with type 2 diabetes and their family members, all of whom are participating in the Botnia Study. There was no overlap between them and the populations for studies I to IV.

The 5,810 individuals in the Botnia Study were from 942 families with an average family size of 6.17. The average number of individuals with type 2 diabetes per family was 2.28 and the average number of individuals not affected was 5.08. OGTT was performed on those patients with type 2 diabetes whose fasting plasma glucose was less than 10 mmol·l⁻¹. The average age, BMI, WHR, fasting glucose and insulin, 2-hour glucose and insulin of individuals with type 2 diabetes were higher and insulin sensitivity and acute beta cell stimulatory responses lower than the respective values in non-diabetic subjects (Table 12).

Table 12. Clinical characteristics of individuals in study V.

Characteristic	All individuals		Non-diabetic individuals	
	<i>n</i>	Mean ± SD	<i>n</i>	Mean ± SD
Male/female	2,691/3,119		1,854/2,168	
T2D (%)	1,707 (29.8)			
Age (years)	5,810	52.68 ± 17.26	4,022	47.22 ± 15.97
BMI (kg·m ⁻²)	5,655	26.58 ± 4.52	3,978	25.79 ± 4.10
WHR	5,554	0.9 ± 0.09	3,930	0.88 ± 0.09
Fasting glucose (mmol·l ⁻¹)	5,744	6.48 ± 2.27	4,008	5.52 ± 0.59
2-hour glucose OGTT (mmol·l ⁻¹)	4,865	7.79 ± 4.23	3,806	6.24 ± 1.58
Fasting Insulin (pmol·l ⁻¹)	5,371	73 ± 63	3,781	50 ± 35
2-hour Insulin OGTT (pmol·l ⁻¹)	4,599	366 ± 337	3,608	328 ± 301
HOMA-R (mmol·mU·l ⁻²)	5,344	3.32 ± 4.08	3,770	2.08 ± 1.35
ISI ((mmol·l) ⁻² ·(mU·l) ²)	4,488	5.56 ± 3.41	3,535	6.24 ± 3.4
HOMA-BETA (%)	5,344	85.89 ± 89.48	3,770	89.63 ± 84.63
IG ₃₀ (%)	4,460	21.41 ± 37.59	3,506	24.6 ± 41.44
DI (mmol·mU·l ⁻²)	4,460	53.35 ± 99.54	3,506	54.69 ± 105.85

T2D: Type 2 diabetes mellitus, ISI: Matsuda insulin sensitivity index, IG₃₀: Insulinogenic index (OGTT ratio of 30 min incremental increase of insulin and glucose), DI: Disposition index (product of HOMA-R and IG₃₀)

11.2 PHENOTYPIC CORRELATIONS

The phenotypic correlations between variables are given in the original publications for studies I to V.

11.3 BMI AND THE RISK OF DEVELOPING TYPE 2 DIABETES MELLITUS (STUDY IV)

The phenotypic correlations between BMI and type 2 diabetes was 0.40 in men and 0.38 in women. The overall HR of type 2 diabetes was 1.22 (95% CI 1.20–1.24) per BMI unit and 1.97 (95% CI 1.87–2.08) per 1 SD of BMI (see Figure 2 in the original publication for study IV). The risk for diabetes increased monotonously after BMI = 20 over the entire BMI spectrum. Altogether 1,332 twins (6.3% of males and 5.1% of females) developed type 2 diabetes by the end of the follow-up, with no significant difference associated with zygosity (HR = 0.93 for DZ twin individuals with 95% CI of 0.82–1.06). The HR of developing type 2 diabetes increased linearly from 1.00 among subjects with normal weight, to 6.80 among obese subjects (BMI = 30–35 kg·m⁻²), when age, sex, physical activity, alcohol consumption, educational status and social class were all used as covariates. In morbidly obese subjects (BMI = 35 kg·m⁻² or more), the risk for type 2 diabetes was twofold, compared with individuals classified as obese.

11.4 TWIN CORRELATIONS

An intraclass correlation coefficient, or intraclass r , measures the similarity of a trait between members within a twin pair: a trait value of twin 1 is compared to the same trait value of twin 2. Monozygotic twins share all their genes and gene combinations, and therefore often display higher intraclass r than DZ twins do. Table 13 is a pooled presentation of the intraclass r values from studies I to IV.

Table 13. Intraclass correlation coefficients of type 2 diabetes and selected metabolic traits from the Finnish Twin Cohort Study.

Pool	Studies I and II		Study III		Study IV	
	MZ	DZ	MZ	DZ	MZ	DZ
T2D female					0.63	0.34
T2D male					0.74	0.34
BMI	0.60	0.04	0.63	0.28		
BMI female			0.67	0.25	0.71	0.34
BMI male			0.62	0.45	0.71	0.41
WHR female	0.89	-0.13	0.69	0.28		
WHR male	0.68	0.08	0.46	0.32		
Fasting glucose	0.46	0.24	0.50	0.37		
Fasting insulin	0.49	-0.06	0.43	0.15		
HOMA-R			0.38	0.04		
Glucose uptake	0.46	0.01				
FPI	0.55	0.24				
LPI	0.66	0.11				
RRI	0.78	0.32				
Sigma	0.67	0.42				
Beta index	0.57	0.23				

T2D: Type 2 diabetes mellitus, FPI: IVGTT first-phase insulin secretion, LPI: IVGTT late-phase insulin secretion, RR: IVGTT readily releasable insulin secretion, Sigma: IVGTT beta cell sensitivity to glucose during the second phase of insulin secretion, Beta index: OGTT compound parameter of beta cell function.

The BMI intraclass r values for study IV represent the situation in 1975. For study III, they were obtained using a subset of the same twins, almost 20 years later. By comparing the ratio of MZ/DZ intraclass r values we can see, that among females, the ratio increased from 2.09 to 2.6 whereas among males it decreased from 1.73 to 1.38. This could indicate that dominance effects increased among women twins while shared environmental influences became more important among aging male twins. However, as the intraclass r values represent the complete populations in studies III and IV, they are not directly comparable.

11.5 HERITABILITY OF TYPE 2 DIABETES AND ASSOCIATED TRAITS

11.5.1 DIRECT ESTIMATES OF HERITABILITY

Heritability, h^2 , is the proportion of trait variance explained by genetic factors. Table 14 summarizes h^2 estimates of the most important traits from all included studies. Also shown in the table are h^2 values of the non-diabetic study population from study V.

Table 14. Heritability estimates of type 2 diabetes and selected diabetes-related traits from the Finnish Twin Cohort Study (studies I to IV) and the Botnia Study (study V).

	Studies I and II		Study III		Study IV		Study V	
	h^2	95% CI	h^2	95% CI	h^2	95% CI	h^2	95% CI
T2D, all							0.25	0.15–0.35
T2D, 35–60 years							0.69	0.38–1.00
T2D, female					0.64	0.52–0.74		
T2D, male					0.73	0.64–0.81		
BMI, all	0.54	0.15–0.93	0.68	0.53–0.78			0.46	0.40–0.52
BMI, non-diabetic							0.53	0.45–0.61
BMI, female			0.75	0.50–1.00	0.71	0.68–0.75		
BMI, male			0.61	0.29–0.93	0.75	0.71–0.78		
WHR, all							0.27	0.21–0.33
WHR, female	0.76	0.13–1.00	0.73	0.47–0.99				
WHR, male	0.70	0.13–1.00	0.48	0.13–0.84				
Fasting glucose	0.14	0.00–0.53	0.45	0.27–0.60			0.58	0.50–0.66
Fasting insulin	0.41	0.02–0.80	0.43	0.23–0.59			0.34	0.26–0.42
HOMA-R			0.42	0.22–0.59			0.37	0.29–0.45
Glucose uptake	0.37	0.00–0.82						
FPI	0.55	0.20–0.90						
LPI	0.58	0.25–0.91						
RRi	0.76	0.53–0.88						
Sigma	0.28	0.00–0.79						
Beta index	0.53	0.26–0.72						
IG ₃₀							0.50	0.42–0.58
DI							0.46	0.38–0.54
ISI							0.40	0.32–0.48

T2D: Type 2 diabetes mellitus, FPI: IVGTT first-phase insulin secretion, LPI: IVGTT late-phase insulin secretion, RR: IVGTT readily releasable insulin secretion, Sigma: IVGTT beta cell sensitivity to glucose during the second phase of insulin secretion, Beta index: OGTT compound parameter of beta cell function, IG₃₀: Insulinogenic index (OGTT ratio of 30 min incremental increase of insulin and glucose), DI: Disposition index (product of HOMA-R and IG₃₀), ISI: Matsuda insulin sensitivity index.

The h^2 values have been discussed in each of the original publications. Only some of the estimates could be compared between studies. The body mass index was measured in all studies and its h^2 was the most constant. The confidence intervals for h^2 for type 2 diabetes did not even overlap when the group 35–60 years, which received the highest estimate, was compared with the group for all individuals (study V). A summary of h^2 estimates of several age groups from study V is separately shown in table 15.

Table 15. Heritability of type 2 diabetes in different age groups in the Botnia Study (study V).

Age group	Number of individuals in the age group	Number (%) of individuals with type 2 diabetes	Heritability estimate (SE) using basic covariates
All	5,326	1,349 (25.3)	0.25 (0.05)
16–60 years	3,760	718 (19.1)	0.50 (0.12)
16–65 years	4,291	949 (22.1)	0.46 (0.10)
16–75 years	5,070	1,262 (24.9)	0.27 (0.07)
35–60 years	2,746	663 (24.1)	0.69 (0.16)
35–65 years	3,277	894 (27.3)	0.56 (0.12)
35–75 years	4,056	1,207 (29.8)	0.31 (0.09)

Basic covariates used: age, sex, age-sex, age-age and BMI

The h^2 for type 2 diabetes among twins in study IV was high among both men (0.73) and women (0.64). This was indirectly also demonstrated in the progression of zygosity-specific relative risk of the non-diabetic co-twin in pairs discordant for type 2 diabetes.

Although studies I to III with small populations were in general characterized by large confidence intervals, traits used for the quantitation of insulin sensitivity (fasting insulin, HOMA-R, clamp glucose uptake and OGTT insulin sensitivity index) all had h^2 estimates around 0.40, regardless of the study, method and population size.

11.5.2 INDIRECT ESTIMATES OF HERITABILITY

The relative risk of a non-affected twin (study III)

Because study III included a follow-up, the time it took for the non-diabetic co-twin of an affected twin to develop type 2 diabetes was measured. The MZ concordance rates (0.41 proband-wise and 0.34 pairwise) were higher than those among DZ twins (0.19 and 0.12). Approximately half of the MZ twins and a third of the DZ twins with an affected co-twin developed type 2 diabetes (Figure 3 in the original publication for study IV). The mean age at the start of the follow-up, sex or the age

at which the first of the twins in a pair was diagnosed with type 2 diabetes, were not significant predictors.

Distribution of quantitative traits across families (study V)

Histograms of Botnia Study family means of the insulinogenic index (IG30) and the insulin sensitivity index (ISI) had a symmetric Gaussian distribution (Figure 1 in the online supplementary material in the original publication for study V). We selected the family means and ranges for 20 families from the lower tail (5%) and 20 families from the upper tail of the trait distributions (Figure 3 in the online supplementary material in the original publication for study V). Although both the insulinogenic index and ISI showed large intrafamilial variance, their interfamily differences were larger.

11.5.3 BIVARIATE ANALYSIS

In study III, Ins_0 and Ins_120 were influenced by a shared genetic factor. Using AE as the final bivariate model, the genetic correlation coefficient (r_g) between the latent polygenetic factors, influencing the variances of both fasting and 2-hour (post-challenge) insulin values, was estimated to be 0.81 and the correlation between the unique environmental influences (r_e) 0.54.

In study IV, up to 28 years of follow-up of 23,585 twins enabled the calculation of r_g between BMI and type 2 diabetes mellitus. Using a bivariate AE model, r_g was estimated to be 0.40 in men and 0.45 in women. To express the result in another way, the genetic covariation with BMI explained 16% (men) and 21% (women) of the genetic covariance of type 2 diabetes mellitus. The coefficients for r_e were 0.37 in men and 0.22 in women.

12. DISCUSSION

This study is the fruit of two successful activities in Finnish medical research: studying type 2 diabetes mellitus and studying twins.

The Finnish Twin Cohort Study (Kaprio 1978, 1994) is a national resource for genetic epidemiological studies. Twins and their families have been ascertained in three different times from the Central Population Register to study the genetic and environmental determinants of common, chronic diseases. In 1992, this data on Finnish twins was used to estimate the cumulative incidence, concordance and heritability of type 1 (insulin-dependent) and type 2 (non-insulin-dependent) diabetes in Finland (Kaprio 1992). The somewhat unexpected observation, that heritability for type 1 diabetes was higher than that for type 2 diabetes, whetted our appetite for testing the extent to which insulin sensitivity and insulin secretion were controlled for by genetic factors. Methods for studying this were already available at the IV Department of Medicine of Helsinki University. Our group there had recently shown for the first time that non-diabetic family members of individuals with type 2 diabetes mellitus were insulin resistant (Eriksson 1989). It was, further, no coincidence that the finding had also inspired the Botnia Study, which included most families with type 2 diabetes in the Ostrobothnia region of western Finland, in a search for the genetic origins of type 2 diabetes (Groop 1996).

These assumptions can be found in the original publications: three publications on insulin-mediated glucose metabolism, insulin secretion and glucose tolerance in a subsample of the Finnish Twin Cohort Study, a prospective study on the heritability of type 2 diabetes using all older cohort twins from the Finnish Twin Cohort Study and, finally, a study on the heritability of type 2 diabetes and related metabolic traits with all available families from the Botnia Study.

One strength of the current thesis is the careful delineation of heritability of type 2 diabetes, insulin sensitivity and insulin secretion. The h^2 estimates for glucose uptake and IVGTT-derived insulin secretion were the first to be published (study I) and have been cited by several authors (Poulsen 2001, Hong 2001, Ashley 2002, Geluk 2004, Stumvoll 2005, Simonis-Bik 2011, Gjesing 2012). The provided h^2 of 0.37 for insulin-stimulated glucose uptake has proven to be in accordance with other studies using euglycaemic hyperinsulinaemic clamp testing (Goodarzi 2005, Poulsen 2005). The significance of h^2 obtained using the clamp technique is increased by studies showing that the genetic correlation between insulin sensitivity estimated using the clamp technique and using HOMA-IR is only moderate (Rasmussen-Torvik 2007).

The timeliest observation from studies I and II has been that the variance of insulin secretion, especially the early phase, is mostly accounted for by genetic factors. The conclusion that IVGTT early insulin secretion could be used as a quantitative

trait, agrees with findings from genome-wide studies, which have highlighted genes associated with insulin secretion rather than with insulin sensitivity. In the NHGRI GWAS Catalogue, accessed on 15 June 2013, out of a total of 100 mapped type 2 diabetes genes, 43 were associated with insulin secretion or the pancreas in general and 24 genes with insulin resistance (Hindorff 2009).

With regard to finding optimal beta cell function phenotypes for genetic studies, two observations from studies I to III deserve mention: (1) genetic factors explained up to three-quarters of the variance of early insulin secretion and (2) in OGTT, the same set of genes seemed to be responsible for 65% of the additive variance of both fasting and 2-hour insulin concentrations. If the early insulin response is the most sensitive predictor for the transition from normoglycaemia to impaired glucose tolerance (Giannini 2012), a model-based estimate obtained from IVGTT would be an optimal phenotyping tool in a search of genes that control beta cell function.

Heritability for type 2 diabetes using all of the Botnia family data was lower than using age groups (study V) or when compared to h^2 obtained from twin data (study IV). The latter estimate can be regarded as the most reliable, as it was based on a follow-up of 28 years. With this in mind, the gender-specific bivariate-model-based h^2 for type 2 diabetes of 64% in male twins and 73% in female twins, and of 69% in Botnia Study individuals of 35–60 years, seem quite comparable.

The weaknesses of both the design and implementation of the current studies have been discussed in the original publications. A principal concern, however, is the use of heritability as an instrument to measure the influence of genetic factors on a trait. The question has taken centre stage since it is apparent that despite the GWASs finding numerous new loci associated with complex traits, the combined effects of these loci seem only to cover a minor part of the estimated trait's h^2 . We, for instance, have shown, that at least two-thirds of the variance of the risk for type 2 diabetes should be due to genes. That is over six times more than the 10% obtained by combining information from all loci in the major GWAS (Voight 2010). At present, there is no clear explanation for this “missing heritability” for type 2 diabetes, or other complex traits (Maher 2008, Manolio 2009). There has been considerable scientific discussion, however, and some of the perspectives raised are mentioned here.

1. The h^2 estimates are inflated.

The preconditions for SEM should be remembered: independency of genetic and environmental effects, independency of environmental effects across individuals and the joint effect of independent additive small genetic effects. Differences in shared environmental influences have, to some extent, been shown to exist (Plomin 1976, Eaves 2003, Richardson 2005) between MZ and DZ twin pairs. Epistatic influences, like DNA methylation and differences in DNA copy number variants seem to accumulate in MZ twins during

their lifetime (Fraga 2005, Bruder 2008). A fundamental feature of studies of phenotypic resemblance within pedigrees is the nature of the kinship coefficient, Φ_{ij} , since heritability estimates are based on a probability-based relatedness of the pedigree members. The h^2 obtained in this way is high compared to the case–control set-up of a GWAS (Visscher 2010).

With these in mind, it is of interest that we, by using (a) a population-based twin approach with a long follow-up and (b) a proband-based large family approach, obtained almost identical h^2 values for type 2 diabetes.

2. The GWASs underestimate h^2 .

According to Peter Visscher, the observed underestimation of GWAS-based heritabilities could be due to a “dilution” of h^2 in case–control approaches of unrelated individuals (Visscher 2010) as well as to the conceptual features of the GWAS approaches in question. The latter includes both the chosen SNP mean allele frequency of 5%, which ignores most of the rarer variants, and the primary question of whether the common disease, common variant idea is relevant at all (Lupski 2011). In 1908 Punnett had to explain why recessive genotypes are not removed, and similarly Gabor Marth wrote in 2011, based upon the 1000 Genomes Exon Pilot Project, that “variants conferring direct changes on protein function will be present mostly at low population frequency” (Marth 2011). This would imply that alleles with a large effect are cleared from a population during evolution and, hence, the expected polygenic variance of common traits would include the input from rare variants. Furthermore, this can be interpreted to mean that recent mutations in populations may have a larger influence on disease susceptibility, or protection, than older ones, which have been attenuated by evolutive forces. Lupski called this “clan genomics” (Lupski 2011).

3. What to do next?

A lively discussion has been ongoing for a number of years and possible ways to lower the MAF to 1% or below have been proposed. In 2010 Yang published an analysis of a GWAS on human height, where all information from 300,000 SNPs was used simultaneously and the relatedness between study subjects was reconstructed using only this SNP information. As a result, the SNP-based h^2 was 45% while using the conventional GWAS approach, it had been around 5% (Yang 2010). Zuk and Lander proposed recently that in addition to calculating the allelic status, a component reflecting the function of the biological processes should be implemented. Using Crohn’s disease as a model, by introducing a variable degree of rate-limiting pathway inputs they were able to explain 80% of Crohn’s disease’s missing h^2 (Zuk 2012). Finally, Finnish researchers recently published a study combining metabolomic

information from nuclear magnetic resonance (NMR) spectroscopy and GWAS data for densely mapped SNPs, and were able to cover 40% of the genetic variance component observed among twins from the Finnish Twin Cohort study (Kettunen 2012).

These approaches outline the future directions for the study of h^2 values of type 2 diabetes as well. We have entered an era of systems biology and tools are emerging that for the first time will enable a fast exploration of the complete genome along with a characterization of phenotypes using hundreds of information points simultaneously. Combined with the increase in computing power, this may be sufficient to begin unravelling the stratified networks that constitute the genome-metabolomes associated with type 2 diabetes mellitus.

This thesis can be seen in the light of the discussion above. It is a compilation of Finnish twin and family studies of complex disorders and, as such, represents groundwork for projects like the Sequencing Initiative Suomi (SISu), which aims to make an almost complete genome variant set available for customized genotyping of samples stored in the National Biobank (Palotie 2013).

13. SUMMARY AND CONCLUSIONS

In this study we have combined information for the older cohort of twins in the population-based Finnish Twin Cohort Study with information for individuals participating in the Botnia Study, which comprises 1,400 families with type 2 diabetes mellitus. Based on the detailed information for the glucose-insulin metabolic axis provided by our investigation and the long follow-up of non-diabetic twins and the pedigree data of type 2 diabetes and related metabolic traits, the following observations can be made:

1. Genetic factors explained much of the risk of getting type 2 diabetes mellitus. The heritability, that is the proportion of variance accounted for by genetic influences, of type 2 diabetes was 64% among female twins and 73% among male twins followed for 28 years, and 69% among 35–65-year-old members of affected families.
2. The variance of glucose-stimulated insulin secretion included a significant genetic component. For the intravenously stimulated first phase of insulin secretion, the heritability varied, according to the model used, from 58% to as high as 76%. The heritability of oral glucose stimulated insulin secretion ranged from 46% to 53%.
3. The heritability of insulin-stimulated glucose disposal, that is insulin sensitivity, was measured as 37% by hyperinsulinaemic euglycaemic clamp testing. Using more surrogate measures, the heritability of insulin sensitivity varied between 37% and 42%.
4. Genetic covariation with BMI explained 16% and 21% of the genetic covariance of type 2 diabetes mellitus in men and women, respectively.

In conclusion, type 2 diabetes mellitus clusters in families, has a high lifetime concordance among MZ twins and results from the complex interplay of genes and the environment. The pancreatic secretion of insulin, and especially the early phase of the secretion, appears to be that part of the metabolism that encompasses the most promising phenotypes for genomic studies of type 2 diabetes.

14. ACKNOWLEDGEMENTS

Originally this work was to be carried out where it began, in the IV Department of Medicine of Helsinki University Hospital, Unioninkatu 38. Nothing, however, is more permanent than change. The institutions where this thesis has been "pending" have changed their names and organizational structures several times. The final affiliations are the Finnish Institute of Molecular Medicine and Department of Public Health in the Hjelt Institute, University of Helsinki.

This work received grant funding from the following institutions, which all are gratefully acknowledged: Finska Läkaresällskapet, Novo Nordisk Foundation, Biomedicum Helsinki Foundation, HUCH Institute, University of Helsinki Funds, The Finnish Medical Foundation, Paulo Foundation, Maud Kuistila Foundation, Foundation for Diabetes Research, The Finnish-Norwegian Medical Foundation, Orion Research Foundation and Doctoral Programs in Public Health (DPPH).

I am grateful to the head of the IV Department of Medicine, Professor Frej Fyhrquist, MD, PhD, for giving me the opportunity to start the work both as a clinician and as a PhD student.

I have had the privilege to work under the supervision of two world class researchers, Professor Leif Groop, MD, PhD and Professor Jaakko Kaprio, MD, PhD. Leif originally introduced me to type 2 diabetes, metabolic syndrome and insulin resistance. This thesis actually started when I, as an assistant physician attending to the diabetes clinic in the small Unioninkatu office, asked him: "So you think adult type diabetes is an inherited muscle disease?" Jaakko has personally taken care that I learned the basics of twin research and has guided me step by step to take over the process of writing and finalizing this thesis. I admire my both supervisors for their everlasting enthusiasm for their disciplines. Thank you, Leif and Jaakko, for your unshakable conviction that this work would be finished!

Every young researcher needs a mentor. I am proud to say that, for me, the mentor has been Professor Riccardo Bonadonna, now the head of the Endocrinology Division in the University of Parma. Riccardo's vast knowledge of mathematics, physics and medicine never stops impressing me! In 1993, Leif told me that I will have an opportunity to host an Italian researcher and that "you will also get a real friend in him." How right Leif was. It is a great pleasure to acknowledge that Riccardo, Marina, Ester and Marco are friends to me and to my family.

The precise work of the official reviewers of this thesis by Professor Sofia Carlsson and Docent Leo Niskanen is gratefully appreciated.

I have greatly benefited from the constructive criticism regarding quantitative genetics by Professor Peter Visscher. I appreciate the feedback offered by Professor Harold Snieder for my first of the original publications. Professor Michael Neale

is thanked, not only for the permission to use figures 8 and 9, but also for his contribution to the development of Mx and OpenMx software.

I acknowledge all the coauthors for their insightful and encouraging comments towards the original publications. I would especially like to express my deepest gratitude and appreciation to Carol Forsblom, Karri Silventoinen and Tiinamaija Tuomi, who have not only coauthored but also primed me to work as a researcher. The collaboration with Kauko Heikkilä, Peter Almgren, Kirsi Pietiläinen, Markku Koskenvuo, Jaakko Tuomilehto, Johan Eriksson and Suichi Katoh has been a pleasure.

My heartfelt appreciation goes to all the skillful laboratory and research staff I have had the pleasure to work with from 1992 onwards: Seija Heikkinen, Esa Laurila, Marja Ben-Ami, Arja Tapio, Helena Åkerfeldt, Leila Pääрни, Leena Sarelin and Maikki Parkkonen. I want to thank Markku Lehto, Timo Kanninen and Auli Kultavirta, as well as all who have participated in the Botnia Study in Finland and in Sweden for their presence in different phases of this work.

I have always felt at home among twin researchers in the Department of Public Health and thank you for collaboration, both past and hopefully also future.

The invaluable and kind support in arranging trips, permissions and contacts by Viveca Metsäaho, Eila Voipio, Ulrika Blom-Nilsson and Sari Kivikko is warmly acknowledged.

I thank diabetologist Timo Valle, MD, for sporty competition during the 90's and for some great spin offs in Keskuskatu and Terveystalo.

I want to thank Giti Khalighi Sikaroudi for the co-work in compiling the diabetic twins database for the original publication IV.

I like to offer my special thanks to Jani Penttinen and Jonathan Webley in Transfluent for the meticulous and superbly fast language editing. I also thank AnnaRosa Lappalainen for introducing me to Jani.

I am indebted to graphic designer Päivi Talonpoika-Ukkonen and Koroste for the fast and skillfull layout.

It has always been a great pleasure to do business with Unigrafia and its predecessors. Thank you Sirpa Pirttipерä and Sara Viuha for producing and printing this thesis.

I owe an important debt to all the institutions that have helped me to earn at least some of our living throughout the years: the HUCH Clinic of Infectious Diseases Aurora Hospital, Terveystalo Mäkelänkatu and Kamppi and Lääkärikeskus Aava Travel Clinic. I have especially enjoyed the weeks spent in writing in the Eastern Finland Sports Institute ISLO and working in Terveystalo Torikatu, Joensuu.

I owe a special debt to Outi Havia, MSc. Without her persistent support this thesis would not have been finished.

I thank also my mobile and agile nutrition-oriented collaborators for the inspiration, as well as pressure, to get this thesis done as soon as possible. Here you have it, Michael Quarshie, Maijaliisa Erkkola, Mikael Fogelholm, Henna Vepsäläinen, Anna Aistrich, Jonna Kekäläinen and Sanna Ritola!

I would like to express my deepest appreciation to all twins participating in the Finnish Twin Cohort Study as well as to all patients and their family members participating in the Botnia Study.

There is a special place in my heart for my cousin Johanna, who scared me to get this thesis done by, without warning finishing her work last year. And, neväforget!, thanks and love to all my friends from and since the medical school: Tero, KK, Jussi, Jose, Tipi, Moe, Juhana, Markus M. as well as Anu, Kirmo, Markus P. and all other brilliant ones.

I express my love for my "family in the broad sense," without whom not a single vacation has passed and with whom I have shared all the important as well as less important moments: Irja, Viki, Vilja, Arttu, Kukka, Leena, Seppo, Ilkka, Laura, Tomi, Tuukka and Atte.

My heartfelt gratitude and love belongs to my "family in the narrow sense": to my parents Liisa and Erkki Lehtovirta and to my brother Matti. You have never let me down and have always been there to provide support and comfort. With you, I have learned to see the world the way I do.

Finally, there is the core of my life: my family in the present tense. No words can convey the love I feel and share with my wife, Päivi, and with our children, Suvituuli and Matias. Thank you for being the most important part of my life!

I have waited for this moment!

In this moist and mild mid-winter morning I am glad and proud to write these words: I finally close the my life chapter of "PhD student."

Helsinki 8.1.2014

Mikko Lehtovirta

15. REFERENCES

- Abraira C, Lawrence AM. The Staub–Traugott phenomenon. III. Effects of starvation. *The American journal of clinical nutrition* 31, 213–21, 1978
- Akinmokun A, Selby PL, Ramaiya K, Alberti KG. The short insulin tolerance test for determination of insulin sensitivity: a comparison with the euglycaemic clamp. *Diabetic medicine : a journal of the British Diabetic Association* 9, 432–7, 1992
- Alberti KG, Christensen NJ, Christensen SE, Hansen AP, Iversen J, Lundbaek K, Seyer-Hansen K, Orskov H. Inhibition of insulin secretion by somatostatin. *Lancet* 2, 1299–301, 1973
- Alberti KG, Zimmet PZ. Definition, diagnosis and classification of diabetes mellitus and its complications. Part 1: diagnosis and classification of diabetes mellitus provisional report of a WHO consultation. *Diabetic medicine : a journal of the British Diabetic Association* 15, 539–53, 1998
- Alberti KG, Daly ME, Robinson A, Marshall SM, Mathers JC. The short insulin tolerance test is safe and reproducible. *Diabetic medicine : a journal of the British Diabetic Association* 16, 352–3, 1999
- Alberti KGMM, Zimmet P, Shaw J. The metabolic syndrome—a new worldwide definition. *Lancet* 366, 1059–62, 2005
- Almasy L, Blangero J. Multipoint quantitative-trait linkage analysis in general pedigrees. *American journal of human genetics* 62, 1198–211, 1998
- Almind K, Bjørbaek C, Vestergaard H, Hansen T, Echwald S, Pedersen O. Aminoacid polymorphisms of insulin receptor substrate-1 in non-insulin-dependent diabetes mellitus. *Lancet* 342, 828–32, 1993
- Altshuler D, Hirschhorn JN, Klannemark M, Lindgren CM, Vohl MC, Nemesh J, Lane CR, Schaffner SF, Bolk S, Brewer C, Tuomi T, Gaudet D, Hudson TJ, Daly M, Groop L, Lander ES. The common PPARgamma Pro12Ala polymorphism is associated with decreased risk of type 2 diabetes. *Nature genetics* 26, 76–80, 2000
- Alvarsson M, Wajngot a, Cerasi E, Efendic S. K-value and low insulin secretion in a non-obese white population: predicted glucose tolerance after 25 years. *Diabetologia* 48, 2262–8, 2005
- Andres R, Baltzan MA, Cader G, Zierler KL. Effect of insulin on carbohydrate metabolism and on potassium in the forearm of man. *The Journal of clinical investigation* 41, 108–15, 1962
- Andres R, Cader G, Zierler KL. The quantitatively minor role of carbohydrate in oxidative metabolism by skeletal muscle in intact man in the basal state; measurements of oxygen and glucose uptake and carbon dioxide and lactate production in the forearm. *The Journal of clinical investigation* 35, 671–82, 1956
- Anon Diabetes mellitus in twins: a cooperative study in Japan. Committee on Diabetic Twins, Japan Diabetes Society. *Diabetes research and clinical practice* 5, 271–80, 1988

- Anon A haplotype map of the human genome. *Nature* 437, 1299–320, 2005
- Anon Notice NOT-OD-07-088. <http://www.grants.nih.gov/grants/guide/notice-files/NOT-OD-07-088.html> (accessed 30 June 2013). 2007
- Ashley MA, Buckley AJ, Criss AL, Ward JA, Kemp A, Garnett S, Cowell CT, Baur LA, Thompson CH. Familial, anthropometric, and metabolic associations of intramyocellular lipid levels in prepubertal males. *Pediatric research* 51, 81–6, 2002
- Ashwell M, Cole TJ, Dixon AK. Obesity: new insight into the anthropometric classification of fat distribution shown by computed tomography. *British medical journal (Clinical research ed.)* 290, 1692–4, 1985
- Balkau B, Charles MA. Comment on the provisional report from the WHO consultation. European Group for the Study of Insulin Resistance (EGIR). *Diabetic medicine : a journal of the British Diabetic Association* 16, 442–3, 1999
- Banting FG, Best CH, Collip JB, Campbell WR, Fletcher AA. Pancreatic extracts in the treatment of Diabetes Mellitus. *Canadian Medical Association journal* 12, 141–6, 1922
- Barnett AH, Eff C, Leslie RD, Pyke DA. Diabetes in identical twins. A study of 200 pairs. *Diabetologia* 20, 87–93, 1981a
- Barnett AH, Spiliopoulos AJ, Pyke DA, Stubbs WA, Burrin J, Alberti KG. Metabolic studies in unaffected co-twins of non-insulin-dependent diabetics. *British medical journal (Clinical research ed.)* 282, 1656–8, 1981b
- Barrett PH, Bell BM, Cobelli C, Golde H, Schumitzky A, Vicini P, Foster DM. SAAM II: Simulation, Analysis, and Modeling Software for tracer and pharmacokinetic studies. *Metabolism: clinical and experimental* 47, 484–92, 1998
- Beard JC, Bergman RN, Ward WK, Porte D. The insulin sensitivity index in nondiabetic man. Correlation between clamp-derived and IVGTT-derived values. *Diabetes* 35, 362–9, 1986
- Bearn AG, Billing BH, Sherlock S. Hepatic glucose output and hepatic insulin sensitivity in diabetes mellitus. *Lancet* 2, 698–701, 1951
- Belfiore F, Iannello S, Volpicelli G. Insulin sensitivity indices calculated from basal and OGTT-induced insulin, glucose, and FFA levels. *Molecular genetics and metabolism* 63, 134–41, 1998
- Bell CG, Walley AJ, Froguel P. The genetics of human obesity. *Nature reviews. Genetics* 6, 221–34, 2005
- Berglund G, Larsson B, Andersson O, Larsson O, Svärdsudd K, Björntorp P, Wilhelmsen L. Body composition and glucose metabolism in hypertensive middle-aged males. *Acta medica Scandinavica* 200, 163–9, 1976
- Bergman RN, Ider YZ, Bowden CR, Cobelli C. Quantitative estimation of insulin sensitivity. *The American journal of physiology* 236, E667–77, 1979
- Bergman RN, Phillips LS, Cobelli C. Physiologic evaluation of factors controlling glucose tolerance in man: measurement of insulin sensitivity and beta-cell glucose sensitivity from the response to intravenous glucose. *The Journal of clinical investigation* 68, 1456–67, 1981

- Bertram R, Sherman A, Satin LS. Metabolic and electrical oscillations: partners in controlling pulsatile insulin secretion. *American journal of physiology. Endocrinology and metabolism* 293, E890–900, 2007
- Bille DS, Banasik K, Justesen JM, Sandholt CH, Sandbæk A, Lauritzen T, Jørgensen T, Witte DR, Holm J-C, Hansen T, Pedersen O. Implications of central obesity-related variants in LYPLAL1, NRXN3, MSRA, and TFAP2B on quantitative metabolic traits in adult Danes. *PLoS one* 6, e20640, 2011
- Bingley PJ, Colman P, Eisenbarth GS, Jackson R a, McCulloch DK, Riley WJ, Gale E a. Standardization of IVGTT to predict IDDM. *Diabetes care* 15, 1313–6, 1992
- Bjørnholt J V, Erikssen G, Liestøl K, Jervell J, Thaulow E, Erikssen J. Type 2 diabetes and maternal family history: an impact beyond slow glucose removal rate and fasting hyperglycemia in low-risk individuals? Results from 22.5 years of follow-up of healthy nondiabetic men. *Diabetes care* 23, 1255–9, 2000
- Boesgaard TW, Gjesing AP, Grarup N, Rutanen J, Jansson P-A, Hribal ML, Sesti G, Fritsche A, Stefan N, Staiger H, Häring H, Smith U, Laakso M, Pedersen O, Hansen T. Variant near ADAMTS9 known to associate with type 2 diabetes is related to insulin resistance in offspring of type 2 diabetes patients—EUGENE2 study. *PLoS one* 4, e7236, 2009
- Bogardus C, Lillioja S, Nyomba BL, Zurlo F, Swinburn B, Esposito-Del Puente A, Knowler WC, Ravussin E, Mott DM, Bennett PH. Distribution of in vivo insulin action in Pima Indians as mixture of three normal distributions. *Diabetes* 38, 1423–32, 1989
- Boker S, Neale M, Maes H, Wilde M, Spiegel M, Brick T, Spies J, Estabrook R, Kenny S, Bates T, Mehta P, Fox J. OpenMx: An Open Source Extended Structural Equation Modeling Framework. *Psychometrika* 76, 306–317, 2011
- Bonadonna RC, Groop L, Kraemer N, Ferrannini E, Del Prato S, DeFronzo RA. Obesity and insulin resistance in humans: a dose-response study. *Metabolism: clinical and experimental* 39, 452–9, 1990
- Bonadonna RC, Stumvoll M, Fritsche A, Muggeo M, Häring H, Bonora E, Van Haeften TW. Altered homeostatic adaptation of first- and second-phase beta-cell secretion in the offspring of patients with type 2 diabetes: studies with a minimal model to assess beta-cell function. *Diabetes* 52, 470–80, 2003
- Bonnevie K. Studies on papillary patterns of human fingers. *Journal of Genetics* 15, 1–111, 1924
- Bonora E, Moghetti P, Zaccanaro C, Cigolini M, Querena M, Cacciatori V, Corgnati A, Muggeo M. Estimates of in vivo insulin action in man: comparison of insulin tolerance tests with euglycemic and hyperglycemic glucose clamp studies. *The Journal of clinical endocrinology and metabolism* 68, 374–8, 1989
- Bonora E, Targher G, Alberiche M, Bonadonna RC, Saggiani F, Zenere MB, Monauni T, Muggeo M. Homeostasis model assessment closely mirrors the glucose clamp technique in the assessment of insulin sensitivity: studies in subjects with various degrees of glucose tolerance and insulin sensitivity. *Diabetes Care* 23, 57–63, 2000
- Bouchard C, Tremblay A, Després JP, Nadeau A, Lupien PJ, Thériault G, Dussault J, Moorjani S, Pinault S, Fournier G. The response to long-term overfeeding in identical twins. *The New England journal of medicine* 322, 1477–82, 1990

- Bouchard C. The biological predisposition to obesity: beyond the thrifty genotype scenario. *International journal of obesity (2005)* 31, 1337–9, 2007
- Breda E, Cavaghan MK, Toffolo G, Polonsky KS, Cobelli C. Oral glucose tolerance test minimal model indexes of beta-cell function and insulin sensitivity. *Diabetes* 50, 150–8, 2001
- Browning LM, Mugridge O, Chatfield MD, Dixon AK, Aitken SW, Joubert I, Prentice AM, Jebb SA. Validity of a new abdominal bioelectrical impedance device to measure abdominal and visceral fat: comparison with MRI. *Obesity (Silver Spring, Md.)* 18, 2385–91, 2010
- Bruder CEG, Piotrowski A, Gijsbers A a CJ, Andersson R, Erickson S, Diaz de Ståhl T, Menzel U, Sandgren J, Von Tell D, Poplawski A, Crowley M, Crasto C, Partridge EC, Tiwari H, Allison DB, Komorowski J, Van Ommen G-JB, Boomsma DI, Pedersen NL, Den Dunnen JT, Wirdefeldt K, Dumanski JP. Phenotypically concordant and discordant monozygotic twins display different DNA copy-number-variation profiles. *American journal of human genetics* 82, 763–71, 2008
- Bush WS, Moore JH. Chapter 11: Genome-wide association studies. *PLoS computational biology* 8, e1002822, 2012
- Butler AE, Janson J, Bonner-Weir S, Ritzel R, Rizza RA, Butler PC. Beta-cell deficit and increased beta-cell apoptosis in humans with type 2 diabetes. *Diabetes* 52, 102–10, 2003
- Byrne MM, Sturis J, Polonsky KS. Insulin secretion and clearance during low-dose graded glucose infusion. *The American journal of physiology* 268, E21–7, 1995
- Camasta S, Manco M, Mari A, Greco A V, Frascerra S, Mingrone G, Ferrannini E. Beta-cell function in severely obese type 2 diabetic patients: long-term effects of bariatric surgery. *Diabetes care* 30, 1002–4, 2007
- Caumo a, Bergman RN, Cobelli C. Insulin sensitivity from meal tolerance tests in normal subjects: a minimal model index. *The Journal of clinical endocrinology and metabolism* 85, 4396–402, 2000
- Van Cauter E, Mestrez F, Sturis J, Polonsky KS. Estimation of insulin secretion rates from C-peptide levels. Comparison of individual and standard kinetic parameters for C-peptide clearance. *Diabetes* 41, 368–77, 1992
- Cederholm J, Wibell L. Evaluation of insulin release and relative peripheral resistance with use of the oral glucose tolerance test: a study in subjects with normoglycaemia, glucose intolerance and non-insulin-dependent diabetes mellitus. *Scandinavian journal of clinical and laboratory investigation* 45, 741–51, 1985
- Cerasi E, Chowers I, Luft R, Widström A. The significance of the blood glucose level for plasma insulin response to intravenously administered tolbutamide in healthy subjects. *Diabetologia* 5, 343–8, 1969
- Cerasi E, Luft R. Insulin response to glucose infusion in diabetic and non-diabetic monozygotic twin pairs. Genetic control of insulin response? *Acta endocrinologica* 55, 330–45, 1967
- Cerasi E. Mechanisms of glucose stimulated insulin secretion in health and in diabetes: some re-evaluations and proposals. *Diabetologia* 11, 1–13, 1975

- Chambers JC, Elliott P, Zabaneh D, Zhang W, Li Y, Froguel P, Balding D, Scott J, Kooner JS. Common genetic variation near MC4R is associated with waist circumference and insulin resistance. *Nature genetics* 40, 716–8, 2008
- Chen CC, Wang TY, Hsu SY, Chen RH, Chang CT, Chen SJ. Is the short insulin tolerance test safe and reproducible? *Diabetic medicine : a journal of the British Diabetic Association* 15, 924–7, 1998
- Cheung WW, Mao P. Recent advances in obesity: genetics and beyond. *ISRN endocrinology* 2012, 536905, 2012
- Cloninger CR, Rice J, Reich T. Multifactorial inheritance with cultural transmission and assortative mating. II. a general model of combined polygenic and cultural inheritance. *Am. J. Hum. Genet.* 31, 176–198, 1979
- Cloninger CR, Rice J, Reich T. Multifactorial inheritance with cultural transmission and assortative mating. III. Family structure and the analysis of separation experiments. *American journal of human genetics* 31, 366–88, 1979
- Coates P a, Luzio SD, Brunel P, Owens DR. Comparison of estimates of insulin sensitivity from minimal model analysis of the insulin-modified frequently sampled intravenous glucose tolerance test and the isoglycemic hyperinsulinemic clamp in subjects with NIDDM. *Diabetes* 44, 631–5, 1995
- Cobelli C, Pacini G, Toffolo G, Saccà L. Estimation of insulin sensitivity and glucose clearance from minimal model: new insights from labeled IVGTT. *Am. J. Physiol.* 250, E591–8, 1986
- Cobelli C, Toffolo GM, Dalla Man C, Campioni M, Denti P, Caumo A, Butler P, Rizza R. Assessment of beta-cell function in humans, simultaneously with insulin sensitivity and hepatic extraction, from intravenous and oral glucose tests. *American journal of physiology. Endocrinology and metabolism* 293, E1–E15, 2007
- Colman PG, Stewart V, Kean J, Koschmann M, Alford F, Ward G, Deam D, Harrison LC. Comparison of two commonly used standard IVGTTs. *Diabetes care* 15, 1053–5, 1992
- Conlon JM. Evolution of the insulin molecule: insights into structure-activity and phylogenetic relationships. *Peptides* 22, 1183–93, 2001
- Cori C, Cori G. The mechanism of epinephrine action II. The influence of epinephrine and insulin on the carbohydrate metabolism of rats in the postabsorptive state. *Journal of Biological Chemistry* 79, 321–341, 1928
- Craig JW, Drucker WR, Miller M, Woodward H. A prompt effect of exogenous insulin on net hepatic glucose output in man. *Metabolism: clinical and experimental* 10, 212–20, 1961
- Cretti A, Lehtovirta M, Bonora E, Brunato B, Zenti MG, Tosi F, Caputo M, Caruso B, Groop LC, Muggeo M, Bonadonna RC. Assessment of beta-cell function during the oral glucose tolerance test by a minimal model of insulin secretion. *European journal of clinical investigation* 31, 405–16, 2001
- Curry DL, Bennett LL, Grodsky GM. Dynamics of insulin secretion by the perfused rat pancreas. *Endocrinology* 83, 572–84, 1968
- Davenport CB. *Body-build and its inheritance*. Carnegie Institution of Washington, Washington, 1923

- Davis LC. Origin of the Punnett's square. *The American Biology Teacher* 55, 209–212, 1993
- Deeb SS, Fajas L, Nemoto M, Pihlajamäki J, Mykkänen L, Kuusisto J, Laakso M, Fujimoto W, Auwerx J. A Pro12Ala substitution in PPAR γ 2 associated with decreased receptor activity, lower body mass index and improved insulin sensitivity. *Nature genetics* 20, 284–7, 1998
- DeFronzo R a. Banting Lecture. From the triumvirate to the ominous octet: a new paradigm for the treatment of type 2 diabetes mellitus. *Diabetes* 58, 773–95, 2009
- DeFronzo RA, Tobin JD, Andres R. Glucose clamp technique: a method for quantifying insulin secretion and resistance. *The American journal of physiology* 237, E214–23, 1979
- DeFronzo RA. Lilly lecture 1987. The triumvirate: beta-cell, muscle, liver. A collusion responsible for NIDDM. *Diabetes* 37, 667–87, 1988
- Demenais F, Kanninen T, Lindgren CM, Wiltshire S, Gaget S, Dandrieux C, Almgren P, Sjögren M, Hattersley A, Dina C, Tuomi T, McCarthy MI, Froguel P, Groop LC. A meta-analysis of four European genome screens (GIFT Consortium) shows evidence for a novel region on chromosome 17p11.2-q22 linked to type 2 diabetes. *Human molecular genetics* 12, 1865–73, 2003
- De Vries H. The origin of species by mutation. *Science (New York, N.Y.)* 15, 721–9, 1902
- Diab DL, D'Alessio D a. The contribution of enteroinsular hormones to the pathogenesis of type 2 diabetes mellitus. *Current diabetes reports* 10, 192–8, 2010
- Dina C, Meyre D, Gallina S, Durand E, Körner A, Jacobson P, Carlsson LMS, Kiess W, Vatn V, Lecoeur C, Delplanque J, Vaillant E, Pattou F, Ruiz J, Weill J, Levy-Marchal C, Horber F, Potoczna N, Hercberg S, Le Stunff C, Bougnères P, Kovacs P, Marre M, Balkau B, Cauchi S, Chèvre J-C, Froguel P. Variation in FTO contributes to childhood obesity and severe adult obesity. *Nature genetics* 39, 724–6, 2007
- DiStefano JK, Taverna DM. Technological issues and experimental design of gene association studies. *Methods in molecular biology (Clifton, N.J.)* 700, 3–16, 2011
- Dorkhan M, Tripathy D, Malm G, Asgharian H, Tuomi T, Groop L. Independent measures of insulin secretion and insulin sensitivity during the same test: the glucagon-insulin tolerance test. *Journal of internal medicine* 264, 62–71, 2008
- Duggirala R, Williams JT, Williams-Blangero S, Blangero J. A variance component approach to dichotomous trait linkage analysis using a threshold model. *Genetic epidemiology* 14, 987–92, 1997
- Dupuis J, Langenberg C, Prokopenko I, Saxena R, Soranzo N, *et al.* New genetic loci implicated in fasting glucose homeostasis and their impact on type 2 diabetes risk. *Nature genetics* 42, 105–16, 2010
- Eaton RP, Allen RC, Schade DS, Erickson KM, Standefer J. Prehepatic insulin production in man: kinetic analysis using peripheral connecting peptide behavior. *The Journal of clinical endocrinology and metabolism* 51, 520–8, 1980
- Eaves L, Foley D, Silberg J. Has the “Equal Environments” assumption been tested in twin studies? *Twin research : the official journal of the International Society for Twin Studies* 6, 486–9, 2003
- Edwards AW. The genetical theory of natural selection. *Genetics* 154, 1419–26, 2000

- Edwards AWF, G. H. Hardy (1908) and Hardy-Weinberg equilibrium. *Genetics* 179, 1143–50, 2008
- Eknoyan G, Adolphe Quetelet (1796-1874)–the average man and indices of obesity. *Nephrol. Dial. Transplant* 23, 47–51, 2008
- Elbein SC, Hasstedt SJ, Wegner K, Kahn SE. Heritability of pancreatic beta-cell function among nondiabetic members of Caucasian familial type 2 diabetic kindreds. *The Journal of clinical endocrinology and metabolism* 84, 1398–403, 1999
- Ellard S, Patrinos GP, Oetting WS. Clinical Applications of Next Generation Sequencing: The 2013 Human Genome Variation Society Scientific Meeting. *Human mutation* (August 17, 2013). doi: 10.1002/humu.22400
- Erasmus RT, Blanco Blanco E, Okesina AB, Mesa Arana J, Gqweta Z, Matsha T. Importance of family history in type 2 black South African diabetic patients. *Postgraduate medical journal* 77, 323–5, 2001
- Eriksson J, Forsén B, Häggblom M, Teppo AM, Groop L. Clinical and metabolic characteristics of type 1 and type 2 diabetes: an epidemiological study from the Närpes community in western Finland. *Diabetic medicine : a journal of the British Diabetic Association* 9, 654–60, 1992
- Eriksson J, Franssila-Kallunki A, Ekstrand A, Saloranta C, Widén E, Schalin C, Groop L. Early metabolic defects in persons at increased risk for non-insulin-dependent diabetes mellitus. *The New England journal of medicine* 321, 337–43, 1989
- Expert Panel on Detection, Evaluation and T of HBC in A. Executive Summary of The Third Report of The National Cholesterol Education Program (NCEP) Expert Panel on Detection, Evaluation, And Treatment of High Blood Cholesterol In Adults (Adult Treatment Panel III). *JAMA : the journal of the American Medical Association* 285, 2486–97, 2001
- Faber OK, Binder C. C-peptide response to glucagon. A test for the residual beta-cell function in diabetes mellitus. *Diabetes* 26, 605–10, 1977
- Falconer DS, Mackay TFC. *Introduction to quantitative genetics*. 4th Edtn. Benjamin Cummings, 1996
- Farooqi IS, Keogh JM, Yeo GSH, Lank EJ, Cheetham T, O’Rahilly S. Clinical spectrum of obesity and mutations in the melanocortin 4 receptor gene. *The New England journal of medicine* 348, 1085–95, 2003
- Fekedulegn DB, Andrew ME, Burchfiel CM, Violanti JM, Hartley T a, Charles LE, Miller DB. Area under the curve and other summary indicators of repeated waking cortisol measurements. *Psychosomatic medicine* 69, 651–9, 2007
- Ferrannini E, Balkau B. Insulin: in search of a syndrome. *Diabetic medicine : a journal of the British Diabetic Association* 19, 724–9, 2002
- Ferrannini E, Gastaldelli A, Miyazaki Y, Matsuda M, Pettiti M, Natali A, Mari A, DeFronzo R a. Predominant role of reduced beta-cell sensitivity to glucose over insulin resistance in impaired glucose tolerance. *Diabetologia* 46, 1211–9, 2003
- Ferrari P, Alleman Y, Shaw S, Riesen W, Weidmann P. Reproducibility of insulin sensitivity measured by the minimal model method. *Diabetologia* 34, 527–30, 1991

- Festa A, Williams K, Hanley AJG, Haffner SM. Beta-cell dysfunction in subjects with impaired glucose tolerance and early type 2 diabetes: comparison of surrogate markers with first-phase insulin secretion from an intravenous glucose tolerance test. *Diabetes* 57, 1638–44, 2008
- Fienberg SE, Hinkley D V. *R.A. Fisher: An Appreciation*. Springer, 1980
- Fisher RA. The correlation between relatives on the supposition of Mendelian inheritance. *Transactions of the Royal Society of Edinburgh* 52, 399–433, 1918
- Fisher RA. *The Genetical Theory of Natural Selection – A Complete Variorum Edition*. Ed: Henry Bennett. Oxford University Press, Oxford, 1999
- Le Floch JP, Escuyer P, Baudin E, Baudon D, Perlemuter L. Blood glucose area under the curve. Methodological aspects. *Diabetes care* 13, 172–5, 1990
- Florey C du V. The use and interpretation of ponderal index and other weight-height ratios in epidemiological studies. *J. Chronic Dis.* 23, 93–103, 1970
- Fraga MF, Ballestar E, Paz MF, Ropero S, Setien F, Ballestar ML, Heine-Suñer D, Cigudosa JC, Urioste M, Benitez J, Boix-Chornet M, Sanchez-Aguilera A, Ling C, Carlsson E, Poulsen P, Vaag A, Stephan Z, Spector TD, Wu Y-Z, Plass C, Esteller M. Epigenetic differences arise during the lifetime of monozygotic twins. *Proceedings of the National Academy of Sciences of the United States of America* 102, 10604–9, 2005
- Franssila-Kallunki A. Comparison of near-infrared light spectroscopy, bioelectrical impedance and tritiated water techniques for the measurement of fat-free mass in humans. *Scandinavian journal of clinical and laboratory investigation* 52, 879–85, 1992
- Frayling TM, Timpson NJ, Weedon MN, Zeggini E, Freathy RM, Lindgren CM, Perry JRB, Elliott KS, Lango H, Rayner NW, Shields B, Harries LW, Barrett JC, Ellard S, Groves CJ, Knight B, Patch A-M, Ness AR, Ebrahim S, Lawlor DA, Ring SM, Ben-Shlomo Y, Jarvelin M-R, Sovio U, Bennett AJ, Melzer D, Ferrucci L, Loos RJF, Barroso I, Wareham NJ, Karpe F, Owen KR, Cardon LR, Walker M, Hitman GA, Palmer CNA, Doney ASF, Morris AD, Smith GD, Hattersley AT, McCarthy MI. A common variant in the FTO gene is associated with body mass index and predisposes to childhood and adult obesity. *Science (New York, N.Y.)* 316, 889–94, 2007
- Frazer KA, Ballinger DG, Cox DR, Hinds DA, Stuve LL, *et al.* A second generation human haplotype map of over 3.1 million SNPs. *Nature* 449, 851–61, 2007
- Frey H, Nântö V, Kulonen E. Serum proteins in Finnish twins. *Acta genetica et statistica medica* 18, 23–30, 1968
- Fuller JL, Thompson RW. *Foundations of behavior genetics*. Mosby, 1979
- Galton F. The history of twins, as a criterion of the relative powers of nature and nurture. *Fraser's Mag. T. Ctry.* : 566–576, 1875
- Galton F. *Natural Inheritance*. Macmillan & co., London, New York, 1889
- Garcia-Webb P, Bonser AM, Whiting D, Masarei JR. Insulin resistance—a risk factor for coronary heart disease? *Scandinavian journal of clinical and laboratory investigation* 43, 677–85, 1983
- Gardner LI, Stern MP, Haffner SM, Gaskill SP, Hazuda HP, Relethford JH, Eifler CW. Prevalence of diabetes in Mexican Americans. Relationship to percent of gene pool derived from native American sources. *Diabetes* 33, 86–92, 1984

- Geluk CA, Halkes CJM, De Jaegere PPT, Plokker TWM, Cabezas MC. Daytime triglyceridemia in normocholesterolemic patients with premature atherosclerosis and in their first-degree relatives. *Metabolism: clinical and experimental* 53, 49–53, 2004
- Gerich JE, Charles MA, Grodsky GM. Characterization of the effects of arginine and glucose on glucagon and insulin release from the perfused rat pancreas. *The Journal of clinical investigation* 54, 833–41, 1974
- Giannini C, Weiss R, Cali A, Bonadonna R, Santoro N, Pierpont B, Shaw M, Caprio S. Evidence for early defects in insulin sensitivity and secretion before the onset of glucose dysregulation in obese youths: a longitudinal study. *Diabetes* 61, 606–14, 2012
- Gilissen C, Hoischen A, Brunner HG, Veltman JA. Disease gene identification strategies for exome sequencing. *European journal of human genetics : EJHG* 20, 490–7, 2012
- Gjesing AP, Ekstrøm CT, Eiberg H, Urhammer SA, Holst JJ, Pedersen O, Hansen T. Fasting and oral glucose-stimulated levels of glucose-dependent insulinotropic polypeptide (GIP) and glucagon-like peptide-1 (GLP-1) are highly familial traits. *Diabetologia* 55, 1338–45, 2012
- Goldstein R. Testing dependent correlation coefficients sg52. *Stata Technical Bulletin STB-32*. : 18, 1996
- Goodarzi MO, Taylor KD, Guo X, Quiñones MJ, Cui J, Li X, Hang T, Yang H, Holmes E, Hsueh WA, Olefsky J, Rotter JI. Variation in the gene for muscle-specific AMP deaminase is associated with insulin clearance, a highly heritable trait. *Diabetes* 54, 1222–7, 2005
- Goodarzi MO, Cui J, Chen Y-DI, Hsueh WA, Guo X, Rotter JI. Fasting insulin reflects heterogeneous physiological processes: role of insulin clearance. *Am. J. Physiol. Endocrinol. Metab.* 301, E402–8, 2011
- Goodner CJ, Walike BC, Koerker DJ, Ensinek JW, Brown AC, Chideckel EW, Palmer J, Kalnasy L. Insulin, glucagon, and glucose exhibit synchronous, sustained oscillations in fasting monkeys. *Science (New York, N.Y.)* 195, 177–9, 1977
- Gottlieb MS, Root HF. Diabetes mellitus in twins. *Diabetes* 17, 693–704, 1968
- Grant SF a, Thorleifsson G, Reynisdottir I, Benediktsson R, Manolescu A, Sainz J, Helgason A, Stefansson H, Emilsson V, Helgadóttir A, Styrkarsdóttir U, Magnusson KP, Walters GB, Palsdóttir E, Jonsdóttir T, Gudmundsdóttir T, Gylfason A, Saemundsdóttir J, Wilensky RL, Reilly MP, Rader DJ, Bagger Y, Christiansen C, Gudnason V, Sigurdsson G, Thorsteinsdóttir U, Gulcher JR, Kong A, Stefansson K. Variant of transcription factor 7-like 2 (TCF7L2) gene confers risk of type 2 diabetes. *Nature genetics* 38, 320–3, 2006
- Greene ME, Blumberg B, McBride OW, Yi HF, Kronquist K, Kwan K, Hsieh L, Greene G, Nimer SD. Isolation of the human peroxisome proliferator activated receptor gamma cDNA: expression in hematopoietic cells and chromosomal mapping. *Gene expression* 4, 281–99, 1995
- Grodsky GM. A threshold distribution hypothesis for packet storage of insulin and its mathematical modeling. *The Journal of clinical investigation* 51, 2047–59, 1972
- Groop L, Forsblom C, Lehtovirta M, Tuomi T, Karanko S, Nissén M, Ehrnström BO, Forsén B, Isomaa B, Snickars B, Taskinen MR. Metabolic consequences of a family history

- of NIDDM (the Botnia Study): evidence for sex-specific parental effects. *Diabetes* 45, 1585–93, 1996
- Gutt M, Davis CL, Spitzer SB, Llabre MM, Kumar M, Czarnecki EM, Schneiderman N, Skyler JS, Marks JB. Validation of the insulin sensitivity index (ISI(0,120)): comparison with other measures. *Diabetes research and clinical practice* 47, 177–84, 2000
- Haffner SM, Stern MP, Hazuda HP, Pugh JA, Patterson JK. Hyperinsulinemia in a population at high risk for non-insulin-dependent diabetes mellitus. *The New England journal of medicine* 315, 220–4, 1986
- Hani EH, Boutin P, Durand E, Inoue H, Permutt MA, Velho G, Froguel P. Missense mutations in the pancreatic islet beta cell inwardly rectifying K⁺ channel gene (KIR6.2/BIR): a meta-analysis suggests a role in the polygenic basis of Type II diabetes mellitus in Caucasians. *Diabetologia* 41, 1511–5, 1998
- Hanis CL, Boerwinkle E, Chakraborty R, Ellsworth DL, Concannon P, Stirling B, Morrison VA, Wapelhorst B, Spielman RS, Gogolin-Ewens KJ, Shepard JM, Williams SR, Risch N, Hinds D, Iwasaki N, Ogata M, Omori Y, Petzold C, Rietzch H, Schröder HE, Schulze J, Cox NJ, Menzel S, Boriraj V V, Chen X, Lim LR, Lindner T, Mereu LE, Wang YQ, Xiang K, Yamagata K, Yang Y, Bell GI. A genome-wide search for human non-insulin-dependent (type 2) diabetes genes reveals a major susceptibility locus on chromosome 2. *Nature genetics* 13, 161–6, 1996
- Harano Y, Ohgaku S, Hidaka H, Haneda K, Kikkawa R, Shigeta Y, Abe H. Glucose, insulin and somatostatin infusion for the determination of insulin sensitivity. *The Journal of clinical endocrinology and metabolism* 45, 1124–7, 1977
- Hardy GH. Mendelian proportions in a mixed population. *Science (New York, N.Y.)* 28, 49–50, 1908
- Harvald B, Hauge M. Selection in diabetes in modern society. *Acta medica Scandinavica* 173, 459–65, 1963
- Hattersley AT, Turner RC, Permutt MA, Patel P, Tanizawa Y, Chiu KC, O’Rahilly S, Watkins PJ, Wainscoat JS. Linkage of type 2 diabetes to the glucokinase gene. *Lancet* 339, 1307–10, 1992
- Heine RJ, Hanning I, Morgan L, Alberti KG. The oral glucose tolerance test (OGTT): effect of rate of ingestion of carbohydrate and different carbohydrate preparations. *Diabetes care* 6, 441–5, 1983
- Heine RJ, Home PD, Poncher M, Orskov H, Hammond V, McCulloch AJ, Hanning I, Alberti KG. A comparison of 3 methods for assessing insulin sensitivity in subjects with normal and abnormal glucose tolerance. *Diabetes research (Edinburgh, Scotland)* 2, 113–20, 1985
- Helakorpi S, Pajunen T, Jallinoja P, Virtanen S, Uutela A. Suomalaisen aikuisväestön terveyskäyttäytyminen ja terveys, kevät 2010: Health Behaviour and Health among the Finnish Adult Population, Spring 2010. Helsinki, 2011
- Henderson M, Rabasa-Lhoret R, Bastard J-P, Chiasson J-L, Baillargeon J-P, Hanley JA, Lambert M. Measuring insulin sensitivity in youth: How do the different indices compare with the gold-standard method? *Diabetes & metabolism* 37, 72–8, 2011

- Henriksen JE, Alford F, Ward G, Thyse-Rønn P, Levin K, Hother-Nielsen O, Rantza C, Boston R, Beck-Nielsen H. Glucose effectiveness and insulin sensitivity measurements derived from the non-insulin-assisted minimal model and the clamp techniques are concordant. *Diabetes/metabolism research and reviews* 26, 569–78, 2010
- Herder C, Roden M. Genetics of type 2 diabetes: pathophysiologic and clinical relevance. *European journal of clinical investigation* 41, 679–92, 2011
- Himsworth HP. Diabetes mellitus: its differentiation into insulin-sensitive and insulin-insensitive types. (Republication of the original in *Lancet* 1936). *Diabetic medicine : a journal of the British Diabetic Association* 28, 1440–4, 2011
- Hindorf LA, Sethupathy P, Junkins HA, Ramos EM, Mehta JP, Collins FS, Manolio TA. Potential etiologic and functional implications of genome-wide association loci for human diseases and traits. *Proceedings of the National Academy of Sciences of the United States of America* 106, 9362–7, 2009
- Hindorf LA, MacArthur J (European Bioinformatics Institute), Morales J (European Bioinformatics Institute), Junkins HA, Hall PN, Klemm AK, Manolio TA. A Catalog of Published Genome-Wide Association Studies. www.genome.gov/gwastudies. (accessed 23 August 2013).
- Hinrichs AL, Suarez BK. Incorporating linkage information into a common disease/rare variant framework. *Genetic epidemiology* 35 Suppl 1, S74–9, 2011
- Hjelmberg J v B, Fagnani C, Silventoinen K, McGue M, Korkeila M, Christensen K, Rissanen A, Kaprio J. Genetic influences on growth traits of BMI: a longitudinal study of adult twins. *Obesity (Silver Spring, Md.)* 16, 847–52, 2008
- Hong Y, Pedersen NL, Brismar K, De Faire U. Genetic and environmental architecture of the features of the insulin-resistance syndrome. *American journal of human genetics* 60, 143–52, 1997
- Hong Y, Weisnagel SJ, Rice T, Sun G, Mandel SA, Gu C, Rankinen T, Gagnon J, Leon AS, Skinner JS, Wilmore JH, Bergman RN, Bouchard C, Rao DC. Familial resemblance for glucose and insulin metabolism indices derived from an intravenous glucose tolerance test in Blacks and Whites of the HERITAGE Family Study. *Clinical genetics* 60, 22–30, 2001
- Hosker JP, Matthews DR, Rudenski AS, Burnett MA, Darling P, Bown EG, Turner RC. Continuous infusion of glucose with model assessment: measurement of insulin resistance and beta-cell function in man. *Diabetologia* 28, 401–11, 1985
- Insel PA, Liljenquist JE, Tobin JD, Sherwin RS, Watkins P, Andres R, Berman M. Insulin control of glucose metabolism in man: a new kinetic analysis. *The Journal of clinical investigation* 55, 1057–66, 1975
- Jarrett RJ. In defence of insulin: a critique of syndrome X. *Lancet* 340, 469–71, 1992
- Jin W, Qin P, Lou H, Jin L, Xu S. A systematic characterization of genes underlying both complex and Mendelian diseases. *Human molecular genetics* 21, 1611–24, 2012
- Jinks JL, Fulker DW. Comparison of the biometrical genetical, MAVA, and classical approaches to the analysis of human behavior. *Psychological bulletin* 73, 311–49, 1970
- Joffe BI, Goldberg RB, Seftel HC, Distiller LA. Insulin, glucose and triglyceride relationships in obese African subjects. *The American journal of clinical nutrition* 28, 616–20, 1975

- Johnson ML, Veldhuis PP, Grimmichova T, Farhy LS, Evans WS. Validation of a deconvolution procedure (AutoDecon) for identification and characterization of fasting insulin secretory bursts. *Journal of diabetes science and technology* 4, 1205–13, 2010
- Jonsson A, Isomaa B, Tuomi T, Taneera J, Salehi A, Nilsson P, Groop L, Lyssenko V. A variant in the KCNQ1 gene predicts future type 2 diabetes and mediates impaired insulin secretion. *Diabetes* 58, 2409–13, 2009
- Jöreskog KG, Van Thillo M. LISREL: A General Computer Program for Estimating a Linear Structural Equation System Involving Multiple Indicators of Unmeasured Variables. Princeton, NJ, 1972
- Jöreskog KG. Analysis of covariance structures. In: Krishnaiah PR (ed). *Multivariate analysis – III: proceedings*. 3rd Edtn. Pp 263–270. Academic Press, New York, 1973
- Jörgensen S, Plum T. On the differential diagnosis between benign and malignant glycosuria by means of intravenous injections of small quantities of grape-sugar. *Acta Medica Scandinavica* 58, 161–200, 1923
- Kahn CR, Roth J, Berson, Yalow, and the JCI: the agony and the ecstasy. *The Journal of clinical investigation* 114, 1051–4, 2004
- Kahn SE, Carr DB, Faulenbach M V, Utzschneider KM. An examination of beta-cell function measures and their potential use for estimating beta-cell mass. *Diabetes, obesity & metabolism* 10 Suppl 4, 63–76, 2008
- Kaprio J, Koskenvuo M. Genetic and environmental factors in complex diseases: the older Finnish Twin Cohort. *Twin research : the official journal of the International Society for Twin Studies* 5, 358–65, 2002
- Kaprio J, Sarna S, Koskenvuo M, Rantasalo I. The Finnish Twin Registry: formation and compilation, questionnaire study, zygosity determination procedures, and research program. *Progress in clinical and biological research* 24 Pt B, 179–84, 1978
- Kaprio J, Tuomilehto J, Koskenvuo M, Romanov K, Reunanen A, Eriksson J, Stengård J, Kesäniemi YA. Concordance for type 1 (insulin-dependent) and type 2 (non-insulin-dependent) diabetes mellitus in a population-based cohort of twins in Finland. *Diabetologia* 35, 1060–7, 1992
- Kaprio J. Lessons from twin studies in Finland. *Annals of medicine* 26, 135–9, 1994
- Karam JH, Grodsky GM, Ching KN, Schmid F, Burrill K, Forsham PH. “Staircase” glucose stimulation of insulin secretion in obesity. Measure of beta-cell sensitivity and capacity. *Diabetes* 23, 763–70, 1974
- Karam JH, Grodsky GM, Forsham PH. Excessive insulin response to glucose in obese subjects as measured by immunochemical assay. *Diabetes* 12, 197–204, 1963
- Katz A, Nambi SS, Mather K, Baron AD, Follmann D a, Sullivan G, Quon MJ. Quantitative insulin sensitivity check index: a simple, accurate method for assessing insulin sensitivity in humans. *The Journal of clinical endocrinology and metabolism* 85, 2402–10, 2000
- Kettunen J, Tukiainen T, Sarin A-P, Ortega-Alonso A, Tikkanen E, Lyytikäinen L-P, Kangas AJ, Soininen P, Würtz P, Silander K, Dick DM, Rose RJ, Savolainen MJ, Viikari J, Kähönen M, Lehtimäki T, Pietiläinen KH, Inouye M, McCarthy MI, Jula A, Eriksson J, Raitakari OT, Salomaa V, Kaprio J, Järvelin M-R, Peltonen L, Perola M, Freimer NB,

- Ala-Korpela M, Palotie A, Ripatti S. Genome-wide association study identifies multiple loci influencing human serum metabolite levels. *Nature genetics* 44, 269–76, 2012
- Keys A, Fidanza F, Karvonen MJ, Kimura N, Taylor HL. Indices of relative weight and obesity. *J. Chronic Dis.* 25, 329–43, 1972
- Khoury MJ, Beaty TH, Cohen BH. *Fundamentals of genetic epidemiology*. 1st Edtn. Oxford University Press, New York, 1993
- Kim SH. Measurement of insulin action: a tribute to Sir Harold Himsworth. *Diabetic medicine : a journal of the British Diabetic Association* 28, 1487–93, 2011
- Kissebah AH, Vydellingum N, Murray R, Evans DJ, Hartz AJ, Kalkhoff RK, Adams PW. Relation of body fat distribution to metabolic complications of obesity. *The Journal of clinical endocrinology and metabolism* 54, 254–60, 1982
- Klatskin G. The response of diabetics to a standard test dose of insulin. *The Journal of clinical investigation* 17, 745–50, 1938
- Kleinwächter L. *Die Lehre von den Zwillingen*. Prag Haerpfer, 1871
- Knowler WC, Pettitt DJ, Savage PJ, Bennett PH. Diabetes incidence in Pima indians: contributions of obesity and parental diabetes. *American journal of epidemiology* 113, 144–56, 1981
- Kong A, Steinthorsdottir V, Masson G, Thorleifsson G, Sulem P, Besenbacher S, Jonasdottir A, Sigurdsson A, Kristinsson KT, Jonasdottir A, Frigge ML, Gylfason A, Olason PI, Gudjonsson S a, Sverrisson S, Stacey SN, Sigurgeirsson B, Benediktsdottir KR, Sigurdsson H, Jonsson T, Benediktsson R, Olafsson JH, Johannsson OT, Hreidarsson AB, Sigurdsson G, Ferguson-Smith AC, Gudbjartsson DF, Thorsteinsdottir U, Stefansson K. Parental origin of sequence variants associated with complex diseases. *Nature* 462, 868–74, 2009
- Korkeila M, Kaprio J, Rissanen A, Koshenvuo M, Sörensen TI. Predictors of major weight gain in adult Finns: stress, life satisfaction and personality traits. *International journal of obesity and related metabolic disorders : journal of the International Association for the Study of Obesity* 22, 949–57, 1998
- Koskenvuo M, Sarna S, Kaprio J. Methodology and structure of the Finnish Twin Registry. 1976
- Koski S. *Diabetesbarometri 2009*. Suomen Diabetesliitto ry, 2010
- Kulonen E. Experience with clinical chemical data of Finnish twins. *Annales medicinae experimentalis et biologiae Fenniae* 45, 178–81, 1967
- Kumento A, Kulonen E. Urinary excretion of 3-methoxy-4-hydroxymandelic acid in Finnish twins. *Acta genetica et statistica medica* 15, 319–26, 1965
- Köbberling J, Tillil H. Empirical risk figures for first degree relatives of non-insulin dependent diabetics. In: Köbberling J, Tattersall R (eds). *The Genetics of Diabetes Mellitus*. Pp 201–209. Academic Press, London, 1982
- Laakso M, Edelman S V, Brechtel G, Baron AD. Decreased effect of insulin to stimulate skeletal muscle blood flow in obese man. A novel mechanism for insulin resistance. *The Journal of clinical investigation* 85, 1844–52, 1990

- Laakso M, Zilinskaite J, Hansen T, Boesgaard TW, Vanttinen M, Stancáková A, Jansson P, Pellmé F, Holst JJ, Kuulasmaa T, Hribal ML, Sesti G, Stefan N, Fritsche A, Häring H, Pedersen O, Smith U. Insulin sensitivity, insulin release and glucagon-like peptide-1 levels in persons with impaired fasting glucose and/or impaired glucose tolerance in the EUGENE2 study. *Diabetologia* 51, 502–11, 2008
- Lander ES, Schork NJ. Genetic dissection of complex traits. *Science New York NY* 265, 2037–48, 1994
- Lander ES. The new genomics: global views of biology. *Science (New York, N.Y.)* 274, 536–9, 1996
- Lang D a, Matthews DR, Burnett M, Turner RC. Brief, irregular oscillations of basal plasma insulin and glucose concentrations in diabetic man. *Diabetes* 30, 435–9, 1981
- Lang DA, Matthews DR, Peto J, Turner RC. Cyclic oscillations of basal plasma glucose and insulin concentrations in human beings. *The New England journal of medicine* 301, 1023–7, 1979
- Lange K. A stochastic model for genetic linkage equilibrium. *Theoretical population biology* 44, 129–48, 1993
- Lee ET, Howard B V, Savage PJ, Cowan LD, Fabsitz RR, Oopik AJ, Yeh J, Go O, Robbins DC, Welty TK. Diabetes and impaired glucose tolerance in three American Indian populations aged 45–74 years. The Strong Heart Study. *Diabetes care* 18, 599–610, 1995
- Lehtovaara A. Psychologische Zwillingsuntersuchungen Vol 39 *Annales Academiae scientiarum Fennicae. Series B, ISSN 0066-2011. Finnischen Literaturgesellschaft, 1938*
- Lehtovirta E. Obesity in relation to glucose tolerance. A cross-sectional anthropometric and retrospective study on Helsinki policemen. *Annals of clinical research* 5, Suppl 10:1–124, 1973
- De Leiva-Pérez A, Brugués-Brugués E, De Leiva-Hidalgo A. From pancreatic extracts to artificial pancreas: history, science and controversies about the discovery of the pancreatic antidiabetic hormone V: The controversy. Who discovered insulin? *Avances en Diabetología* 26, 373–382, 2010
- Li CC. Pseudo-random mating populations. In celebration of the 80th anniversary of the Hardy-Weinberg law. *Genetics* 119, 731–7, 1988
- Lillioja S, Mott DM, Zawadzki JK, Young AA, Abbott WG, Knowler WC, Bennett PH, Moll P, Bogardus C. In vivo insulin action is familial characteristic in nondiabetic Pima Indians. *Diabetes* 36, 1329–35, 1987
- Liu A, Kushida C a, Reaven GM. Risk for obstructive sleep apnea in obese, nondiabetic adults varies with insulin resistance status. *Sleep & breathing = Schlaf & Atmung* 17, 333–8, 2013
- Liu D, Moberg E, Kollind M, Lins PE, Adamson U, Macdonald IA. Arterial, arterialized venous, venous and capillary blood glucose measurements in normal man during hyperinsulinaemic euglycaemia and hypoglycaemia. *Diabetologia* 35, 287–90, 1992
- Loos R.JF. Genetic determinants of common obesity and their value in prediction. *Best practice & research. Clinical endocrinology & metabolism* 26, 211–26, 2012

- Lorenzo C, Haffner SM, Stancáková A, Laakso M. Relation of direct and surrogate measures of insulin resistance to cardiovascular risk factors in nondiabetic finnish offspring of type 2 diabetic individuals. *The Journal of clinical endocrinology and metabolism* 95, 5082–90, 2010
- Lovie P. Statistical software for microcomputers: News and reviews. *British Journal of Mathematical and Statistical Psychology* 42, 273–278, 1989
- Lozner EL, Winkler AW, Taylor FH, Peters JP. The intravenous glucose tolerance test. *The Journal of clinical investigation* 20, 507–15, 1941
- Lundbaek K. Intravenous glucose tolerance as a tool in definition and diagnosis of diabetes mellitus. *British medical journal* 1, 1507–13, 1962
- Lupski JR, Belmont JW, Boerwinkle E, Gibbs R a. Clan genomics and the complex architecture of human disease. *Cell* 147, 32–43, 2011
- Lyssenko V, Almgren P, Anevski D, Orho-Melander M, Sjögren M, Saloranta C, Tuomi T, Groop L. Genetic prediction of future type 2 diabetes. *PLoS medicine* 2, e345, 2005
- Lyssenko V, Lupi R, Marchetti P, Del Guerra S, Orho-Melander M, Almgren P, Sjögren M, Ling C, Eriksson K-F, Lethagen A-L, Mancarella R, Berghlund G, Tuomi T, Nilsson P, Del Prato S, Groop L. Mechanisms by which common variants in the TCF7L2 gene increase risk of type 2 diabetes. *The Journal of clinical investigation* 117, 2155–63, 2007
- Macbryde CM. Response to insulin as an index to the dietary management of diabetes. *The Journal of clinical investigation* 15, 577–89, 1936
- MacLean CJ, Morton NE, Lew R. Analysis of family resemblance. IV. Operational characteristics of segregation analysis. *American journal of human genetics* 27, 365–84, 1975
- Magkos F, Wang X, Mittendorfer B. Metabolic actions of insulin in men and women. *Nutrition (Burbank, Los Angeles County, Calif.)* 26, 686–93, 2010
- Magnello E. Victorian Values: The Origin of Modern Statistics. Icon Books, Ltd., 2004
- Maher B. Personal genomes: The case of the missing heritability. *Nature* 456, 18–21, 2008
- Manolio TA, Collins FS, Cox NJ, Goldstein DB, Hindorff LA, Hunter DJ, McCarthy MI, Ramos EM, Cardon LR, Chakravarti A, Cho JH, Guttmacher AE, Kong A, Kruglyak L, Mardis E, Rotimi CN, Slatkin M, Valle D, Whittemore AS, Boehnke M, Clark AG, Eichler EE, Gibson G, Haines JL, Mackay TFC, McCarroll SA, Visscher PM. Finding the missing heritability of complex diseases. *Nature* 461, 747–53, 2009
- Mari A, Camastra S, Toschi E, Giancaterini A, Gastaldelli A, Mingrone G, Ferrannini E. A model for glucose control of insulin secretion during 24 h of free living. *Diabetes* 50 Suppl 1, S164–8, 2001
- Mari A, Tura A, Gastaldelli A, Ferrannini E. Assessing insulin secretion by modeling in multiple-meal tests: role of potentiation. *Diabetes* 51 Suppl 1, S221–6, 2002
- Marth GT, Yu F, Indap AR, Garimella K, Gravel S, Leong WF, Tyler-Smith C, Bainbridge M, Blackwell T, Zheng-Bradley X, Chen Y, Challis D, Clarke L, Ball E V, Cibulskis K, Cooper DN, Fulton B, Hartl C, Koboldt D, Muzny D, Smith R, Sougnez C, Stewart C, Ward A, Yu J, Xue Y, Altshuler D, Bustamante CD, Clark AG, Daly M, DePristo

- M, Flicek P, Gabriel S, Mardis E, Palotie A, Gibbs R. The functional spectrum of low-frequency coding variation. *Genome biology* 12, R84, 2011
- Martin NG, Eaves LJ. The genetical analysis of covariance structure. *Heredity* 38, 79–95, 1977
- Mather K, Jinks JL. *Biometrical genetics: the study of continuous variation*. 3rd Edtn. Chapman and Hall, London, 1982
- Mather K. *Biometrical Genetics: The study of continuous variation*. Dover Publications, 1949
- Matsuda A, Kuzuya T. Relationship between obesity and concordance rate for type 2 (non-insulin-dependent) diabetes mellitus among twins. *Diabetes research and clinical practice* 26, 137–43, 1994
- Matsuda M, DeFronzo R a. Insulin sensitivity indices obtained from oral glucose tolerance testing: comparison with the euglycemic insulin clamp. *Diabetes care* 22, 1462–70, 1999
- Matthews DR, Hosker JP, Rudenski AS, Naylor BA, Treacher DF, Turner RC. Homeostasis model assessment: insulin resistance and beta-cell function from fasting plasma glucose and insulin concentrations in man. *Diabetologia* 28, 412–9, 1985
- Matveyenko A V, Liuwantara D, Gurlo T, Kirakossian D, Dalla Man C, Cobelli C, White MF, Copps KD, Volpi E, Fujita S, Butler PC. Pulsatile portal vein insulin delivery enhances hepatic insulin action and signaling. *Diabetes* 61, 2269–79, 2012
- Mayer EJ, Newman B, Austin M a, Zhang D, Quesenberry CP, Edwards K, Selby J V. Genetic and environmental influences on insulin levels and the insulin resistance syndrome: an analysis of women twins. *American journal of epidemiology* 143, 323–32, 1996
- Mayo O. A century of Hardy-Weinberg equilibrium. *Twin research and human genetics : the official journal of the International Society for Twin Studies* 11, 249–56, 2008
- McIntyre N, Holdsworth CD, Turner DS. Intestinal factors in the control of insulin secretion. *The Journal of clinical endocrinology and metabolism* 25, 1317–24, 1965
- McNair PD, Colman PG, Alford FP, Harrison LC. Reproducibility of the first-phase insulin response to intravenous glucose is not improved by retrograde cannulation and arterialization or the use of a lower glucose dose. *Diabetes Care* 18, 1168–73, 1995
- Medici F, Hawa M, Ianari A, Pyke D a, Leslie RD. Concordance rate for type II diabetes mellitus in monozygotic twins: actuarial analysis. *Diabetologia* 42, 146–50, 1999
- Meier JJ, Veldhuis JD, Butler PC. Pulsatile insulin secretion dictates systemic insulin delivery by regulating hepatic insulin extraction in humans. *Diabetes* 54, 1649–56, 2005
- Meigs JB, Cupples LA, Wilson PW. Parental transmission of type 2 diabetes: the Framingham Offspring Study. *Diabetes* 49, 2201–7, 2000
- Mellinkoff SM, Frankland M, Greipel M. Effect of amino acid and glucose ingestion on arteriovenous blood sugar and appetite. *Journal of applied physiology* 9, 85–7, 1956
- Merriman C. The intellectual resemblance of twins. *Psychol. Monogr.* 33, i–58, 1924
- Metzker ML. Sequencing technologies - the next generation. *Nature reviews. Genetics* 11, 31–46, 2010
- Minton JAL, Hattersley AT, Owen K, McCarthy MI, Walker M, Latif F, Barrett T, Frayling TM. Association studies of genetic variation in the WFS1 gene and type 2 diabetes in U.K. populations. *Diabetes* 51, 1287–90, 2002

- Mirsky IA, Kaplan SM, Podore CJ, Broh-Kahn RH. The insulin tolerance test in patients with essential hypertension. *The Journal of clinical investigation* 29, 297–301, 1950
- Mitchell BD, Valdez R, Hazuda HP, Haffner SM, Monterrosa A, Stern MP. Differences in the prevalence of diabetes and impaired glucose tolerance according to maternal or paternal history of diabetes. *Diabetes care* 16, 1262–7, 1993
- Mitrakou A, Vuorinen-Markkola H, Raptis G, Toft I, Mokan M, Strumph P, Pimenta W, Veneman T, Jenssen T, Bolli G. Simultaneous assessment of insulin secretion and insulin sensitivity using a hyperglycemia clamp. *The Journal of clinical endocrinology and metabolism* 75, 379–82, 1992
- Morris AD, Ueda S, Petrie JR, Connell JM, Elliott HL, Donnelly R. The euglycaemic hyperinsulinaemic clamp: an evaluation of current methodology. *Clin. Exp. Pharmacol. Physiol.* 24, 513–8, 1997
- Morton NE, MacLean CJ. Analysis of family resemblance. 3. Complex segregation of quantitative traits. *American journal of human genetics* 26, 489–503, 1974
- Morton NE. Letter: Controversial issues in human population genetics. *American journal of human genetics* 26, 259–62, 1974a
- Morton NE. Analysis of family resemblance. I. Introduction. *American journal of human genetics* 26, 318–30, 1974b
- Muniyappa R, Lee S, Chen H, Quon MJ. Current approaches for assessing insulin sensitivity and resistance in vivo: advantages, limitations, and appropriate usage. *American journal of physiology. Endocrinology and metabolism* 294, E15–26, 2008
- Murphy R, Ellard S, Hattersley AT. Clinical implications of a molecular genetic classification of monogenic beta-cell diabetes. *Nature clinical practice. Endocrinology & metabolism* 4, 200–13, 2008
- Murray CJL, Lopez AD. In: *Global Health Statistics: Global Burden of Disease and Injury Series 2*. Harvard University Press, Boston, MA, 1996
- Mylykangas S, Koskenvuo JW, Alastalo T-P. [Novel high-throughput sequencing strategies in genetic diagnostics]. *Duodecim; lääketieteellinen aikakauskirja* 129, 141–8, 2013
- Narkiewicz K, Chrostowska M, Kuchta G, Szczech R, Welz A, Rynkiewicz A, Lysiak-Szydłowska W, Pawłowski R, Krupa-Wojciechowska B. Genetic influences on insulinemia in normotensive twins. *American journal of hypertension* 10, 467–70, 1997
- Neale MC, Cardon LR. *Methodology for genetic studies of twins and families number 67* NATO ASI Series: Series D: Behavioural and social sciences. Springer, 1992
- Neale MC, Maes HH. *Methodology for genetic studies of twins and families*. Kluwer Academic Publishers B.V., Dordrecht, the Netherlands, 2004
- Neel J V. Diabetes mellitus: a “thrifty” genotype rendered detrimental by “progress”? *American journal of human genetics* 14, 353–62, 1962
- Newman B, Selby J V, King MC, Slemenda C, Fabsitz R, Friedman GD. Concordance for type 2 (non-insulin-dependent) diabetes mellitus in male twins. *Diabetologia* 30, 763–8, 1987
- Newman HH, Freeman FN, Holzinger KL. *Twins A study of heredity and environment*. The University of Chicago Press, Chicago, IL, 1937

- Nittala A, Ghosh S, Stefanovski D, Bergman R, Wang X. Dimensional analysis of MINMOD leads to definition of the disposition index of glucose regulation and improved simulation algorithm. *Biomedical engineering online* 5, 44, 2006
- Nolan CJ, Damm P, Prentki M. Type 2 diabetes across generations: from pathophysiology to prevention and management. *Lancet* 378, 169–81, 2011
- Okorodudu DO, Jumean MF, Montori VM, Romero-Corral A, Somers VK, Erwin PJ, Lopez-Jimenez F. Diagnostic performance of body mass index to identify obesity as defined by body adiposity: a systematic review and meta-analysis. *Int. J. Obes. (Lond)*. 34, 791–9, 2010
- O’Rahilly SP, Nugent Z, Rudenski AS, Hosker JP, Burnett MA, Darling P, Turner RC. Beta-cell dysfunction, rather than insulin insensitivity, is the primary defect in familial type 2 diabetes. *Lancet* 2, 360–4, 1986
- Olson JM, Cordell HJ. Ascertainment bias in the estimation of sibling genetic risk parameters. *Genetic epidemiology* 18, 217–35, 2000
- Palmer JP, Benson JW, Walter RM, Ensink JW. Arginine-stimulated acute phase of insulin and glucagon secretion in diabetic subjects. *The Journal of clinical investigation* 58, 565–70, 1976
- Palotie A, Widén E, Ripatti S. From genetic discovery to future personalized health research. *New biotechnology* 30, 291–5, 2013
- Partanen J, Bruun K, Markkanen T. Inheritance of drinking behavior: A study on intelligence, personality, and use of alcohol of adult twins. Finnish Foundation for Alcohol Studies, Helsinki, 1966
- Penrose LS. The detection of autosomal linkage in data which consist of pairs of brothers and sisters of unspecified parentage. *Annals of Eugenics* 6, 133–138, 1935
- Phillips DI, Clark PM, Hales CN, Osmond C. Understanding oral glucose tolerance: comparison of glucose or insulin measurements during the oral glucose tolerance test with specific measurements of insulin resistance and insulin secretion. *Diabetic medicine : a journal of the British Diabetic Association* 11, 286–92, 1994
- Pikkarainen J, Kulonen E. Variation of blood haemoglobin in Finnish twins. *Clinica chimica acta; international journal of clinical chemistry* 10, 496–504, 1964a
- Pikkarainen J, Kulonen E. Variation of blood sugar in Finnish twins. *Annales medicinae experimentalis et biologiae Fenniae* 42, 117–20, 1964b
- Pikkarainen J, Takkunen J, Kulonen E. Serum cholesterol in Finnish twins. *American journal of human genetics* 18, 115–26, 1966
- Pilkis SJ, Fox E, Wolfe L, Rothbarth L, Colosia A, Stewart HB, El-Maghrabi MR. Hormonal modulation of key hepatic regulatory enzymes in the gluconeogenic/glycolytic pathway. *Annals of the New York Academy of Sciences* 478, 1–19, 1986
- Pimenta W, Korytkowski M, Mitrakou A, Jenssen T, Yki-Jarvinen H, Evron W, Dailey G, Gerich J. Pancreatic beta-cell dysfunction as the primary genetic lesion in NIDDM. Evidence from studies in normal glucose-tolerant individuals with a first-degree NIDDM relative. *JAMA : the journal of the American Medical Association* 273, 1855–61, 1995

- Plomin R, Willerman L, Loehlin JC. Resemblance in appearance and the equal environments assumption in twin studies of personality traits. *Behavior genetics* 6, 43–52, 1976
- Pollin W, Allen MG, Hoffer A, Stabenau JR, Hrubec Z. Psychopathology in 15,909 pairs of veteran twins: evidence for a genetic factor in the pathogenesis of schizophrenia and its relative absence in psychoneurosis. *The American journal of psychiatry* 126, 597–610, 1969
- Polonsky KS, Given BD, Van Cauter E. Twenty-four-hour profiles and pulsatile patterns of insulin secretion in normal and obese subjects. *The Journal of clinical investigation* 81, 442–8, 1988
- Polonsky KS. Lilly Lecture 1994. The beta-cell in diabetes: from molecular genetics to clinical research. *Diabetes* 44, 705–17, 1995
- Poulsen P, Kyvik KO, Vaag A, Beck-Nielsen H. Heritability of type II (non-insulin-dependent) diabetes mellitus and abnormal glucose tolerance—a population-based twin study. *Diabetologia* 42, 139–45, 1999
- Poulsen P, Levin K, Petersen I, Christensen K, Beck-Nielsen H, Vaag A. Heritability of insulin secretion, peripheral and hepatic insulin action, and intracellular glucose partitioning in young and old Danish twins. *Diabetes* 54, 275–83, 2005
- Poulsen P, Vaag A. Glucose and insulin metabolism in twins: influence of zygosity and birth weight. *Twin research: the official journal of the International Society for Twin Studies* 4, 350–5, 2001
- Prentice AM. The emerging epidemic of obesity in developing countries. *International journal of epidemiology* 35, 93–9, 2006
- Prescott CA. Using the Mplus computer program to estimate models for continuous and categorical data from twins. *Behavior genetics* 34, 17–40, 2004
- Provine WB. *The Origins of Theoretical Population Genetics*. University of Chicago Press, Chicago, IL, 1971
- Pyke DA, Theophanides CG, Tattersall RB. Genetic origin of diabetes: Re-evaluation of twin data. *Lancet* 2, 464, 1976
- Pyke DA. Twin studies in diabetes. *Progress in clinical and biological research* 24 Pt C, 1–11, 1978
- Pyke DA. Diabetes: the genetic connections. *Diabetologia* 17, 333–43, 1979
- Pyörälä K. Relationship of glucose tolerance and plasma insulin to the incidence of coronary heart disease: results from two population studies in Finland. *Diabetes care* 2, 131–41, 1979
- Qi L, Cornelis MC, Kraft P, Stanya KJ, Linda Kao WH, Pankow JS, Dupuis J, Florez JC, Fox CS, Paré G, Sun Q, Girman CJ, Laurie CC, Mirel DB, Manolio T a, Chasman DI, Boerwinkle E, Ridker PM, Hunter DJ, Meigs JB, Lee C-H, Hu FB, Van Dam RM. Genetic variants at 2q24 are associated with susceptibility to type 2 diabetes. *Human molecular genetics* 19, 2706–15, 2010
- Quetelet AM. *A Treatise of Man and the Development of his Faculties*. First. William and Robert Chambers, Edinburgh, 1842

- Rahier J, Guiot Y, Goebbels RM, Sempoux C, Henquin JC. Pancreatic beta-cell mass in European subjects with type 2 diabetes. *Diabetes, obesity & metabolism* 10 Suppl 4, 32–42, 2008
- Rankinen T, Zuberi A, Chagnon YC, Weisnagel SJ, Argyropoulos G, Walts B, Pérusse L, Bouchard C. The human obesity gene map: the 2005 update. *Obesity (Silver Spring, Md.)* 14, 529–644, 2006
- Rao DC, Morton NE, Yee S. Analysis of family resemblance. II. A linear model for familial correlation. *American journal of human genetics* 26, 331–59, 1974
- Rao DC, Morton NE. Path analysis of family resemblance in the presence of gene-environment interaction. *American journal of human genetics* 26, 767–72, 1974a
- Rask E, Olsson T, Söderberg S, Holst Jj J j, Tura A, Pacini G, Ahrén B. Insulin secretion and incretin hormones after oral glucose in non-obese subjects with impaired glucose tolerance. *Metabolism: clinical and experimental* 53, 624–31, 2004
- Rasmussen-Torvik LJ, Pankow JS, Jacobs DR, Steffen LM, Moran AM, Steinberger J, Sinaiko AR. Heritability and genetic correlations of insulin sensitivity measured by the euglycaemic clamp. *Diabetic medicine : a journal of the British Diabetic Association* 24, 1286–9, 2007
- Reaven GM. Banting lecture 1988. Role of insulin resistance in human disease. *Diabetes* 37, 1595–607, 1988
- Reaven GM. The metabolic syndrome: requiescat in pace. *Clinical chemistry* 51, 931–8, 2005
- Reinauer H, Home PD, Kanagasabapathy AS, Heuck C-C. World Health Organization Laboratory diagnosis and monitoring of diabetes mellitus. 2002
- Rice J, Cloninger CR, Reich T. Multifactorial inheritance with cultural transmission and assortative mating. I. Description and basic properties of the unitary models. *American journal of human genetics* 30, 618–43, 1978
- Richardson K, Norgate S. The equal environments assumption of classical twin studies may not hold. *The British journal of educational psychology* 75, 339–50, 2005
- Risch N, Merikangas K. The future of genetic studies of complex human diseases. *Science (New York, N.Y.)* 273, 1516–7, 1996
- Roberts HF, Mendel G (1822–1884). *Plant hybridization before Mendel*. Princeton University Press, Princeton, NJ, 1929
- Rodbell M. Metabolism of isolated fat cells. I. Effects of hormones on glucose metabolism and lipolysis. *The Journal of biological chemistry* 239, 375–80, 1964
- Rorsman P, Eliasson L, Renström E, Gromada J, Barg S, Göpel S. The cell physiology of biphasic insulin secretion. News in physiological sciences : an international journal of physiology produced jointly by the International Union of Physiological Sciences and the American Physiological Society 15, 72–77, 2000
- Rorsman P, Renström E. Insulin granule dynamics in pancreatic beta cells. *Diabetologia* 46, 1029–45, 2003
- Ross R, Léger L, Morris D, De Guise J, Guardo R. Quantification of adipose tissue by MRI: relationship with anthropometric variables. *Journal of applied physiology (Bethesda, Md. : 1985)* 72, 787–95, 1992

- Rung J, Cauchi S, Albrechtsen A, Shen L, Rocheleau G, Cavalcanti-Proença C, Bacot F, Balkau B, Belisle A, Borch-Johnsen K, Charpentier G, Dina C, Durand E, Elliott P, Hadjadj S, Järvelin M-R, Laitinen J, Lauritzen T, Marre M, Mazur A, Meyre D, Montpetit A, Pisinger C, Posner B, Poulsen P, Pouta A, Prentki M, Ribel-Madsen R, Ruokonen A, Sandbaek A, Serre D, Tichet J, Vaxillaire M, Wojtaszewski JFP, Vaag A, Hansen T, Polychronakos C, Pedersen O, Froguel P, Sladek R. Genetic variant near *IRS1* is associated with type 2 diabetes, insulin resistance and hyperinsulinemia. *Nature genetics* 41, 1110–5, 2009
- Rushton AR. Nettleship, Pearson and Bateson: the biometric-Mendelian debate in a medical context. *Journal of the history of medicine and allied sciences* 55, 134–57, 2000
- Sachidanandam R, Weissman D, Schmidt SC, Kakol JM, Stein LD, Marth G, Sherry S, Mullikin JC, Mortimore BJ, Willey DL, Hunt SE, Cole CG, Coggill PC, Rice CM, Ning Z, Rogers J, Bentley DR, Kwok PY, Mardis ER, Yeh RT, Schultz B, Cook L, Davenport R, Dante M, Fulton L, Hillier L, Waterston RH, McPherson JD, Gilman B, Schaffner S, Van Etten WJ, Reich D, Higgins J, Daly MJ, Blumenstiel B, Baldwin J, Stange-Thomann N, Zody MC, Linton L, Lander ES, Altshuler D. A map of human genome sequence variation containing 1.42 million single nucleotide polymorphisms. *Nature* 409, 928–33, 2001
- Sakul H, Pratley R, Cardon L, Ravussin E, Mott D, Bogardus C. Familiality of physical and metabolic characteristics that predict the development of non-insulin-dependent diabetes mellitus in Pima Indians. *American journal of human genetics* 60, 651–6, 1997
- Sammalisto L. The determination of zygosity in a study of Finnish twins. *Acta genetica et statistica medica* 11, 251–64, 1961
- Samols E, Marri G, Marks V. Promotion of insulin secretion by glucagon. *Lancet* 2, 415–6, 1965
- Sargeant LA, Wareham NJ, Khaw KT. Family history of diabetes identifies a group at increased risk for the metabolic consequences of obesity and physical inactivity in EPIC-Norfolk: a population-based study. The European Prospective Investigation into Cancer. *International journal of obesity and related metabolic disorders : journal of the International Association for the Study of Obesity* 24, 1333–9, 2000
- Sarna S, Kaprio J, Sistonen P, Koskenvuo M. Diagnosis of twin zygosity by mailed questionnaire. *Human heredity* 28, 241–54, 1978
- Sarna S, Koskenvuo M, Kaprio J, Rantasalo I. Data procedure of the Finnish Twin Register: compilation and mailing. 1976
- Saxena R, Voight BF, Lyssenko V, Burt NP, De Bakker PIW, *et al.* Genome-wide association analysis identifies loci for type 2 diabetes and triglyceride levels. *Science (New York, N.Y.)* 316, 1331–6, 2007
- Schalin-Jääntti C, Härkönen M, Groop LC. Impaired activation of glycogen synthase in people at increased risk for developing NIDDM. *Diabetes* 41, 598–604, 1992
- Schäfer S a, Machicao F, Fritsche A, Häring H-U, Kantartzis K. New type 2 diabetes risk genes provide new insights in insulin secretion mechanisms. *Diabetes research and clinical practice* 93 Suppl 1, S9–24, 2011
- Scott LJ, Mohlke KL, Bonnycastle LL, Willer CJ, Li Y, Duren WL, Erdos MR, Stringham HM, Chines PS, Jackson AU, Prokunina-Olsson L, Ding C-J, Swift AJ, Narisu N, Hu

- T, Pruim R, Xiao R, Li X-Y, Conneely KN, Riebow NL, Sprau AG, Tong M, White PP, Hetrick KN, Barnhart MW, Bark CW, Goldstein JL, Watkins L, Xiang F, Saramies J, Buchanan T a, Watanabe RM, Valle TT, Kinnunen L, Abecasis GR, Pugh EW, Doheny KF, Bergman RN, Tuomilehto J, Collins FS, Boehnke M. A genome-wide association study of type 2 diabetes in Finns detects multiple susceptibility variants. *Science (New York, N.Y.)* 316, 1341–5, 2007
- Segal KR, Gutin B, Presta E, Wang J, Van Itallie TB. Estimation of human body composition by electrical impedance methods: a comparative study. *Journal of applied physiology (Bethesda, Md. : 1985)* 58, 1565–71, 1985
- Seltzer HS, Allen EW, Herron AL, Brennan MT. Insulin secretion in response to glycemic stimulus: relation of delayed initial release to carbohydrate intolerance in mild diabetes mellitus. *The Journal of clinical investigation* 46, 323–35, 1967
- Seltzer HS, Smith WL. Plasma insulin activity after glucose: an index of insulogenic reserve in normal and diabetic man. *Diabetes* 8, 417–24, 1959
- Shaten BJ, Smith GD, Kuller LH, Neaton JD. Risk factors for the development of type II diabetes among men enrolled in the usual care group of the Multiple Risk Factor Intervention Trial. *Diabetes care* 16, 1331–9, 1993
- Shaw JE, Sicree RA, Zimmet PZ. Global estimates of the prevalence of diabetes for 2010 and 2030. *Diabetes research and clinical practice* 87, 4–14, 2010
- Shen SW, Reaven GM, Farquhar JW. Comparison of impedance to insulin-mediated glucose uptake in normal subjects and in subjects with latent diabetes. *The Journal of clinical investigation* 49, 2151–60, 1970
- Sherwin RS, Kramer KJ, Tobin JD, Insel PA, Liljenquist JE, Berman M, Andres R. A model of the kinetics of insulin in man. *The Journal of clinical investigation* 53, 1481–92, 1974
- Siemens HW. Die Zwillingspathologie: ihre Bedeutung, ihre Methodik, ihre bisherigen Ergebnisse. J.Springer, Berlin, 1924
- Simmons R a. Developmental origins of beta-cell failure in type 2 diabetes: the role of epigenetic mechanisms. *Pediatric research* 61, 64R–67R, 2007
- Simonis-Bik AMC, Boomsma DI, Dekker JM, Diamant M, De Geus EJC, ‘t Hart LM, Heine RJ, Kramer MHH, Maassen JA, Mari A, Tura A, Willemsen G, Eekhoff EMW. The heritability of beta cell function parameters in a mixed meal test design. *Diabetologia* 54, 1043–51, 2011
- Sladek R, Rocheleau G, Rung J, Dina C, Shen L, Serre D, Boutin P, Vincent D, Belisle A, Hadjadj S, Balkau B, Heude B, Charpentier G, Hudson TJ, Montpetit A, Pshezhetsky A V, Prentki M, Posner BI, Balding DJ, Meyre D, Polychronakos C, Froguel P. A genome-wide association study identifies novel risk loci for type 2 diabetes. *Nature* 445, 881–5, 2007
- Smith CP, Tarn AC, Thomas JM, Overkamp D, Corakci A, Savage MO, Gale EA. Between and within subject variation of the first-phase insulin response to intravenous glucose. *Diabetologia* 31, 123–5, 1988
- Smith GD, Ebrahim S. “Mendelian randomization”: can genetic epidemiology contribute to understanding environmental determinants of disease? *International journal of epidemiology* 32, 1–22, 2003

- Snieder H, Boomsma DI, Van Doornen LJ, Neale MC. Bivariate genetic analysis of fasting insulin and glucose levels. *Genetic epidemiology* 16, 426–46, 1999
- Somogyi M. Studies of arteriovenous differences in blood sugar. V. Effect of epinephrine on the rate of glucose assimilation. *The Journal of biological chemistry* 186, 513–26, 1950
- Soonthornpun S, Setasuban W, Thamprasit A, Chayanunnukul W, Rattarasarn C, Geater A. Novel insulin sensitivity index derived from oral glucose tolerance test. *The Journal of clinical endocrinology and metabolism* 88, 1019–23, 2003
- Sparsø T, Grarup N, Andreassen C, Albrechtsen A, Holmkvist J, Andersen G, Jørgensen T, Borch-Johnsen K, Sandbaek A, Lauritzen T, Madsbad S, Hansen T, Pedersen O. Combined analysis of 19 common validated type 2 diabetes susceptibility gene variants shows moderate discriminative value and no evidence of gene-gene interaction. *Diabetologia* 52, 1308–14, 2009
- Speliotes EK, Willer CJ, Berndt SI, Monda KL, Thorleifsson G, *et al.* Association analyses of 249,796 individuals reveal 18 new loci associated with body mass index. *Nature genetics* 42, 937–48, 2010
- Spielman RS, Ewens WJ. The TDT and other family-based tests for linkage disequilibrium and association. *American journal of human genetics* 59, 983–9, 1996
- Stark AE. A clarification of the Hardy-Weinberg law. *Genetics* 174, 1695–7, 2006
- StataCorp. Stata Statistical Software: Release 8. StataCorp LP. 2003
- Staub H. Untersuchungen über den Zuckerstoffwechsel des Menschen. *Zeitschrift für Klinische Medizin* 91, 44–60, 1921
- Steil GM, Murray J, Bergman RN, Buchanan TA. Repeatability of insulin sensitivity and glucose effectiveness from the minimal model. Implications for study design. *Diabetes* 43, 1365–71, 1994
- Steiner DF, Cunningham D, Spigelman L, Aten B. Insulin biosynthesis: evidence for a precursor. *Science (New York, N.Y.)* 157, 697–700, 1967
- Steiner DF. Proinsulin and the biosynthesis of insulin. *The New England journal of medicine* 280, 1106–13, 1969
- Steiner DF. The proinsulin C-peptide-a multirole model. *Experimental diabetes research* 5, 7–14, 2004
- Steinthorsdottir V, Thorleifsson G, Reynisdottir I, Benediktsson R, Jonsdottir T, Walters GB, Styrkarsdottir U, Gretarsdottir S, Emilsson V, Ghosh S, Baker A, Snorrardottir S, Bjarnason H, Ng MCY, Hansen T, Bagger Y, Wilensky RL, Reilly MP, Adeyemo A, Chen Y, Zhou J, Gudnason V, Chen G, Huang H, Lashley K, Doumatey A, So W-Y, Ma RCY, Andersen G, Borch-Johnsen K, Jorgensen T, Van Vliet-Ostapchouk J V, Hofker MH, Wijmenga C, Christiansen C, Rader DJ, Rotimi C, Gurney M, Chan JCN, Pedersen O, Sigurdsson G, Gulcher JR, Thorsteinsdottir U, Kong A, Stefansson K. A variant in CDKAL1 influences insulin response and risk of type 2 diabetes. *Nature genetics* 39, 770–5, 2007
- Stern C. The Hardy-Weinberg law. *Science (New York, N.Y.)* 97, 137–8, 1943
- Stern C, Sherwood ER, Mendel G (1822–1884). *The Origin of Genetics: A Mendel Source Book*. W.H. Freeman, CA, USA, San Francisco, CA, 1966

- Stout RW. The relationship of abnormal circulating insulin levels to atherosclerosis. *Atherosclerosis* 27, 1–13, 1977
- Stumvoll M, Goldstein BJ, Van Haeften TW. Type 2 diabetes: principles of pathogenesis and therapy. *Lancet* 365, 1333–46, 2005
- Stumvoll M, Van Haeften T, Fritsche A, Gerich J. Oral glucose tolerance test indexes for insulin sensitivity and secretion based on various availabilities of sampling times. *Diabetes care* 24, 796–7, 2001
- Stumvoll M, Mitrakou A, Pimenta W, Jenssen T, Yki-Järvinen H, Van Haeften T, Renn W, Gerich J. Use of the oral glucose tolerance test to assess insulin release and insulin sensitivity. *Diabetes care* 23, 295–301, 2000
- Stunkard AJ, Harris JR, Pedersen NL, McClearn GE. The body-mass index of twins who have been reared apart. *The New England journal of medicine* 322, 1483–7, 1990
- Suarez BK, Rice J, Reich T. The generalized sib pair IBD distribution: its use in the detection of linkage. *Annals of human genetics* 42, 87–94, 1978
- Sun XJ, Rothenberg P, Kahn CR, Backer JM, Araki E, Wilden PA, Cahill DA, Goldstein BJ, White MF. Structure of the insulin receptor substrate IRS-1 defines a unique signal transduction protein. *Nature* 352, 73–7, 1991
- Svensgaard E, Andersen H. I. Blood sugar in normal adults. *Acta Paediatrica* 12, 10–20, 1931
- Tan MH, Havel RJ, Gerich JE, Soeldner JS, Kane JP. Pancreatic alpha and beta cell function in familial dysbetalipoproteinemia. *Hormone and metabolic research = Hormon- und Stoffwechselforschung = Hormones et métabolisme* 12, 421–5, 1980
- Tattersall RB, Pyke DA. Diabetes in identical twins. *Lancet* 2, 1120–5, 1972
- Then Berg H. Die Erbbiologie des Diabetes mellitus. *Arch. für Rassen- und Gesellschaftsbiologie* 32, 289–340, 1938
- Thorndike EL. Measurement of twins. *Archives of Philosophy, Psychology and Scientific Methods* 1, 1–64, 1905
- Toffolo G, Bergman RN, Finegood DT, Bowden CR, Cobelli C. Quantitative estimation of beta cell sensitivity to glucose in the intact organism: a minimal model of insulin kinetics in the dog. *Diabetes* 29, 979–90, 1980
- Toffolo G, De Grandi F, Cobelli C. Estimation of beta-cell sensitivity from intravenous glucose tolerance test C-peptide data. Knowledge of the kinetics avoids errors in modeling the secretion. *Diabetes* 44, 845–54, 1995
- Toyota T, Kudo M, Abe K, Goto Y. Plasma C-peptide response to oral glucose in low insulin responders, subdiabetic, and diabetic subjects. *The Tohoku journal of experimental medicine* 121, 99–104, 1977
- Traugott K. Über das Verhalten des Blutzucker spiegels bei wiederholter und verschiedener art enteraler Zuckersufuhr and dessen. Bedeutung für die Leberfunktion. *Klinische Wochenschrift* 1, 892, 1922
- Tripathy D, Wessman Y, Gullström M, Tuomi T, Groop L. Importance of obtaining independent measures of insulin secretion and insulin sensitivity during the same test: results with the Botnia clamp. *Diabetes care* 26, 1395–401, 2003

- Tripathy D, Almgren P, Tuomi T, Groop L. Contribution of insulin-stimulated glucose uptake and basal hepatic insulin sensitivity to surrogate measures of insulin sensitivity. *Diabetes care* 27, 2204–10, 2004
- Tsai F-J, Yang C-F, Chen C-C, Chuang L-M, Lu C-H, Chang C-T, Wang T-Y, Chen R-H, Shiu C-F, Liu Y-M, Chang C-C, Chen P, Chen C-H, Fann CSJ, Chen Y-T, Wu J-Y. A genome-wide association study identifies susceptibility variants for type 2 diabetes in Han Chinese. *PLoS genetics* 6, e1000847, 2010
- Turner RC, Holman RR, Matthews D, Hockaday TD, Peto J. Insulin deficiency and insulin resistance interaction in diabetes: estimation of their relative contribution by feedback analysis from basal plasma insulin and glucose concentrations. *Metabolism: clinical and experimental* 28, 1086–96, 1979
- Unoki H, Takahashi A, Kawaguchi T, Hara K, Horikoshi M, Andersen G, Ng DPK, Holmkvist J, Borch-Johnsen K, Jørgensen T, Sandbaek A, Lauritzen T, Hansen T, Nurbaya S, Tsunoda T, Kubo M, Babazono T, Hirose H, Hayashi M, Iwamoto Y, Kashiwagi A, Kaku K, Kawamori R, Tai ES, Pedersen O, Kamatani N, Kadowaki T, Kikkawa R, Nakamura Y, Maeda S. SNPs in KCNQ1 are associated with susceptibility to type 2 diabetes in East Asian and European populations. *Nature genetics* 40, 1098–102, 2008
- Vaag a, Henriksen JE, Madsbad S, Holm N, Beck-Nielsen H. Insulin secretion, insulin action, and hepatic glucose production in identical twins discordant for non-insulin-dependent diabetes mellitus. *The Journal of clinical investigation* 95, 690–8, 1995
- Valle T, Tuomilehto J, Bergman RN, Ghosh S, Hauser ER, Eriksson J, Nylund SJ, Kohtamäki K, Toivanen L, Vidgren G, Tuomilehto-Wolf E, Ehnholm C, Blaschak J, Langefeld CD, Watanabe RM, Magnuson V, Ally DS, Hagopian WA, Ross E, Buchanan TA, Collins F, Boehnke M. Mapping genes for NIDDM. Design of the Finland-United States Investigation of NIDDM Genetics (FUSION) Study. *Diabetes care* 21, 949–58, 1998
- Vauhkonen I, Niskanen L, Vanninen E, Kainulainen S, Uusitupa M, Laakso M. Defects in insulin secretion and insulin action in non-insulin-dependent diabetes mellitus are inherited. Metabolic studies on offspring of diabetic probands. *The Journal of clinical investigation* 101, 86–96, 1998
- Vicini P, Bonadonna RC, Lehtovirta M, Groop LC, Cobelli C. Estimation of blood flow heterogeneity in human skeletal muscle using intravascular tracer data: importance for modeling transcapillary exchange. *Annals of biomedical engineering* 26, 764–74, 1998
- Visscher P. Multiple linear regression & twin data on two traits. Personal communication: Letter to John Hopper. 2006
- Visscher PM, Hill WG, Wray NR. Heritability in the genomics era—concepts and misconceptions. *Nat. Rev. Genet.* 9, 255–66, 2008
- Visscher PM, Yang J, Goddard ME. A commentary on “common SNPs explain a large proportion of the heritability for human height” by Yang et al. (2010). *Twin research and human genetics : the official journal of the International Society for Twin Studies* 13, 517–24, 2010
- Visscher PM, Brown M a, McCarthy MI, Yang J. Five years of GWAS discovery. *The American Journal of Human Genetics* 90, 7–24, 2012

- Voight BF, Scott LJ, Steinthorsdottir V, Morris AP, Dina C, *et al.* Twelve type 2 diabetes susceptibility loci identified through large-scale association analysis. *Nature genetics* 42, 579–89, 2010
- Vos T, Flaxman AD, Naghavi M, Lozano R, Michaud C, *et al.* Years lived with disability (YLDs) for 1160 sequelae of 289 diseases and injuries 1990–2010: a systematic analysis for the Global Burden of Disease Study 2010. *Lancet* 380, 2163–96, 2012
- Waife SO. Nutritional etymology. *The American journal of clinical nutrition* 3, 149, 1955
- Ward WK, Bolgiano DC, McKnight B, Halter JB, Porte D. Diminished B cell secretory capacity in patients with noninsulin-dependent diabetes mellitus. *The Journal of clinical investigation* 74, 1318–28, 1984
- Warner JP, Leek JP, Intody S, Markham AF, Bonthron DT. Human glucokinase regulatory protein (GCKR): cDNA and genomic cloning, complete primary structure, and chromosomal localization. *Mammalian genome : official journal of the International Mammalian Genome Society* 6, 532–6, 1995
- Watanabe RM, Valle T, Hauser ER, Ghosh S, Eriksson J, Kohtamäki K, Ehnholm C, Tuomilehto J, Collins FS, Bergman RN, Boehnke M. Familiality of quantitative metabolic traits in Finnish families with non-insulin-dependent diabetes mellitus. Finland-United States Investigation of NIDDM Genetics (FUSION) Study investigators. *Human heredity* 49, 159–68, 1999
- Weeks DE, Lange K. The affected-pedigree-member method of linkage analysis. *American journal of human genetics* 42, 315–26, 1988
- Weiss R, Caprio S, Trombetta M, Taksali SE, Tamborlane W V, Bonadonna R. Beta-cell function across the spectrum of glucose tolerance in obese youth. *Diabetes* 54, 1735–43, 2005
- The Wellcome Trust Case Control Consortium. Genome-wide association study of 14,000 cases of seven common diseases and 3,000 shared controls. *Nature* 447, 661–78, 2007
- Wetterstrand K. DNA Sequencing Costs: Data from the NHGRI Genome Sequencing Program (GSP). www.genome.gov/sequencingcosts (accessed 24 August 2013).
- White MF, Shoelson SE, Keutmann H, Kahn CR. A cascade of tyrosine autophosphorylation in the beta-subunit activates the phosphotransferase of the insulin receptor. *The Journal of biological chemistry* 263, 2969–80, 1988
- WHO. World Health Organization Technical Report Series 310: Diabetes Mellitus Report of a WHO Expert committee. 1965
- WHO. World Health Organization Technical Report Series 646: WHO Expert Committee on Diabetes Mellitus Second report. 1980
- WHO. WHO Consultation 1999 Definition, diagnosis and classification of diabetes mellitus and its complications: part 1. Diagnosis and classification of diabetes mellitus (report no. 99.2). Geneva, Switzerland, 1999
- WHO. WHO Technical Report Series 894 Obesity: Preventing and Managing The Global Epidemic. Geneva, Switzerland, 2000
- WHO. Definition and diagnosis of diabetes mellitus and intermediate hyperglycemia: report of a WHO/IDF consultation. 2006

- WHO. Obesity and overweight. *Fact sheet N°311*. <http://www.who.int/mediacentre/factsheets/fs311/en/> (accessed 10 July 2013). 2013
- Wild S, Roglic G, Green A, Sicree R, King H. Global prevalence of diabetes: estimates for the year 2000 and projections for 2030. *Diabetes care* 27, 1047–53, 2004
- Williams CJ, Christian JC, Norton JA. TWINAN90: a FORTRAN program for conducting ANOVA-based and likelihood-based analyses of twin data. *Comput. Methods Programs Biomed.* 38, 167–76, 1992
- Winckler W, Burt NP, Holmkvist J, Cervin C, de Bakker PIW, Sun M, Almgren P, Tuomi T, Gaudet D, Hudson TJ, Ardlie KG, Daly MJ, Hirschhorn JN, Altshuler D, Groop L. Association of common variation in the HNF1alpha gene region with risk of type 2 diabetes. *Diabetes* 54, 2336–42, 2005
- Wright S. Systems of Mating. I. the Biometric Relations between Parent and Offspring. *Genetics* 6, 111–23, 1921
- Wright S. Evolution in Mendelian Populations. *Genetics* 16, 97–159, 1931
- Wright S. The Method of Path Coefficients. *The Annals of Mathematical Statistics* 5, 161–215, 1934
- Yalow RS, Berson SA. Immunoassay of endogenous plasma insulin in man. *The Journal of clinical investigation* 39, 1157–75, 1960
- Yang J, Benyamin B, McEvoy BP, Gordon S, Henders AK, Nyholt DR, Madden PA, Heath AC, Martin NG, Montgomery GW, Goddard ME, Visscher PM. Common SNPs explain a large proportion of the heritability for human height. *Nature genetics* 42, 565–9, 2010
- Yasuda K, Miyake K, Horikawa Y, Hara K, Osawa H, Furuta H, Hirota Y, Mori H, Jonsson A, Sato Y, Yamagata K, Hinokio Y, Wang H-Y, Tanahashi T, Nakamura N, Oka Y, Iwasaki N, Iwamoto Y, Yamada Y, Seino Y, Maegawa H, Kashiwagi A, Takeda J, Maeda E, Shin HD, Cho YM, Park KS, Lee HK, Ng MCY, Ma RCW, So W-Y, Chan JCN, Lyssenko V, Tuomi T, Nilsson P, Groop L, Kamatani N, Sekine A, Nakamura Y, Yamamoto K, Yoshida T, Tokunaga K, Itakura M, Makino H, Nanjo K, Kadowaki T, Kasuga M. Variants in KCNQ1 are associated with susceptibility to type 2 diabetes mellitus. *Nature genetics* 40, 1092–7, 2008
- Yeh KC, Kwan KC. A comparison of numerical integrating algorithms by trapezoidal, Lagrange, and spline approximation. *Journal of pharmacokinetics and biopharmaceutics* 6, 79–98, 1978
- Yeni-Komshian H, Carantoni M, Abbasi F, Reaven GM. Relationship between several surrogate estimates of insulin resistance and quantification of insulin-mediated glucose disposal in 490 healthy nondiabetic volunteers. *Diabetes care* 23, 171–5, 2000
- Zeggini E, Scott LJ, Saxena R, Voight BF, Marchini JL, et al. Meta-analysis of genome-wide association data and large-scale replication identifies additional susceptibility loci for type 2 diabetes. *Nature genetics* 40, 638–45, 2008
- Zeggini E, Weedon MN, Lindgren CM, Frayling TM, Elliott KS, Lango H, Timpson NJ, Perry JRB, Rayner NW, Freathy RM, Barrett JC, Shields B, Morris AP, Ellard S, Groves CJ, Harries LW, Marchini JL, Owen KR, Knight B, Cardon LR, Walker M, Hitman GA, Morris AD, Doney ASF, McCarthy MI, Hattersley AT. Replication of genome-wide

association signals in UK samples reveals risk loci for type 2 diabetes. *Science (New York, N.Y.)* 316, 1336–41, 2007

Zierler K, Andres R. Muscle glucose uptake does not increase when only local arterial glucose concentration is increased. *Diabetes* 51, 2698–702, 2002

Zierler K. Whole body glucose metabolism. *The American journal of physiology* 276, E409–26, 1999

Zuk O, Hechter E, Sunyaev SR, Lander ES. The mystery of missing heritability: Genetic interactions create phantom heritability. *Proceedings of the National Academy of Sciences of the United States of America* 109, 1193–8, 2012

16. ORIGINAL PUBLICATIONS

