

Research Article

Stabilizability and Disturbance Rejection with State-Derivative Feedback

Manoel R. Moreira, Edson I. Mainardi Júnior, Talita T. Esteves, Marcelo C. M. Teixeira, Rodrigo Cardim, Edvaldo Assunção, and Flávio A. Faria

Departamento de Engenharia Elétrica, Faculdade de Engenharia de Ilha Solteira, Universidade Estadual Paulista (UNESP), 15385-000 Ilha Solteira, SP, Brazil

Correspondence should be addressed to Marcelo C. M. Teixeira, marcelo@dee.feis.unesp.br

Received 23 September 2010; Accepted 9 December 2010

Academic Editor: Fernando Lobo Pereira

Copyright © 2010 Manoel R. Moreira et al. This is an open access article distributed under the Creative Commons Attribution License, which permits unrestricted use, distribution, and reproduction in any medium, provided the original work is properly cited.

In some practical problems, for instance in the control of mechanical systems using accelerometers as sensors, it is easier to obtain the state-derivative signals than the state signals. This paper shows that (i) linear time-invariant plants given by the state-space model matrices $\{A, B, C, D\}$ with output equal to the state-derivative vector are not observable and can not be stabilizable by using an output feedback if $\det(A) = 0$ and (ii) the rejection of a constant disturbance added to the input of the aforementioned plants, considering $\det(A) \neq 0$, and a static output feedback controller is not possible. The proposed results can be useful in the analysis and design of control systems with state-derivative feedback.

1. Introduction

There exist many results in the literature on the feedback control of systems described through state variables [1]. State feedback or output feedback is usually used, but in some cases the state-derivative feedback can be very useful to achieve a desired performance [2].

In the last years, the state-derivative feedback of linear systems has been studied by some researchers. In [3], the authors proposed a formula similar to the Ackermann formula, for the pole-placement design with a state-derivative feedback gain. In [4, 5], a linear quadratic regulator (LQR) controller design scheme for standard state-space systems was presented. The procedure described in [6] allows the design of state-derivative feedback control systems using state feedback design methods. Other results about the pole placement of multivariable system, with state-derivative feedback, can be found in [7–13].

There exist some practical problems where the state-derivative signals are easier to obtain than the state signals, for instance, in the control of mechanical systems for the suppression of vibration, where the main sensors are accelerometers. In this case, from the signals of the accelerometers it is possible to reconstruct the velocities with a good precision but not the displacements [3]. Defining the velocities and displacements as the state variables, one has available feedback for the state-derivative signals. Because of their low cost, accelerometers have been used in the industry, for instance, in the following applications: suppression of vibration in mechanical systems [3, 14, 15], control of car wheel suspension systems [16], aeronautical engineering [5, 15], and civil engineering [4]. Recently, new LMI-based state-derivative feedback design methods have been presented [17, 18]. These design methods allow new specifications and also the consideration of a broader class of plants than the related results available in the literature [3, 4, 7, 16–19].

This paper investigates the observability, stabilizability, and disturbance rejection of linear time-invariant plants given by the state-space model matrices $\{A, B, C, D\}$, with output equal to the state-derivative vector. Section 2 shows that if $\det(A) = 0$, then the aforementioned plants are not observable, are unstable (because they have at least one pole equal to zero), and cannot be stabilizable by using output feedback. The assumption $\det(A) \neq 0$ has been considered in the linear state-derivative designs [3, 6, 7, 17–20]. The proposed results in Section 2 elucidate and give more details about the condition $\det(A) = 0$. The necessity of the condition $\det(A) \neq 0$, considering the state-derivative feedback, is a new result offered in this paper. Section 3 shows that if $\det(A) \neq 0$, then the plants $\{A, B, C, D\}$ cited above present at least one transmission zero equal to zero. Furthermore, due to this fact, as described in Section 3, the disturbance rejection of a constant disturbance added to the plant input is not possible, by using a static state-derivative feedback. This conclusion does not invalidate the application of the state-derivative feedback controllers, because the main use of these controllers is in the suppression of vibrations, where the disturbances usually have a mean value equal to zero. This paper is an expanded and updated version of [21]. Other results about the stabilizability and stability robustness of state-derivative feedback, including the fragility, can be found in [22].

2. Observability and Stabilizability of Systems with State-Derivative Feedback

In the control of linear time-invariant systems, represented by the state-space model matrices $\{A, B, C, D\}$, the design of state-derivative feedback usually supposes that $\det(A) \neq 0$ [3, 6, 7, 17–19]. In this paper this condition is investigated with details and related with the observability and stability of this system. The main idea in this study was the representation of the state-derivative vector $\dot{x}(t)$ as the output of this system, $y(t)$.

Lemma 2.1. *Consider the linear time-invariant system, with input $u(t)$ and output $y(t)$ described by*

$$\begin{aligned} \dot{x}(t) &= Ax(t) + Bu(t), \\ y(t) &= \dot{x}(t) = Ax(t) + Bu(t) = Cx(t) + Du(t), \end{aligned} \tag{2.1}$$

where $A \in \mathbb{R}^{n \times n}$, $B \in \mathbb{R}^{n \times m}$, and $x(t) \in \mathbb{R}^{n \times 1}$.

Then, this system is observable if and only if $\det(A) \neq 0$.

Proof. Note that the matrices of the system (2.1) are the following: $\{A, B, C, D\} = \{A, B, A, B\}$. The observability matrix of the system (2.1) is given by [23]

$$\mathcal{O} = \begin{pmatrix} C \\ CA \\ CA^2 \\ \vdots \\ CA^{n-1} \end{pmatrix} = \begin{pmatrix} A \\ A^2 \\ A^3 \\ \vdots \\ A^n \end{pmatrix} = \begin{pmatrix} I_n \\ A \\ A^2 \\ \vdots \\ A^{n-1} \end{pmatrix} A. \quad (2.2)$$

Then, from (2.2), it follows from the Sylvester inequality [23] that

$$\text{rank}(\mathcal{O}) = \text{rank} \left(\begin{pmatrix} \begin{pmatrix} I_n \\ A \\ A^2 \\ \vdots \\ A^{n-1} \end{pmatrix} \\ A \end{pmatrix} \right) = \text{rank}(A) = n \quad (2.3)$$

if and only if $\det(A) \neq 0$. Thus, the system (2.1) is observable if and only if $\det(A) \neq 0$. \square

The next lemma presents results about the poles of the system (2.1), when $\det(A) = 0$.

Lemma 2.2. *Suppose that $\det(A) = 0$ and $\text{rank}(A) = q < n$. Then, the system (2.1) can be decomposed, by an equivalent transformation, into observable and unobservable parts, and the unobservable part has $n - q$ poles at $s = 0$.*

Proof. Since $\det(A) = 0$ and $\text{rank}(A) = q < n$, the matrix A can be represented as follows:

$$A = RA_0, \quad (2.4)$$

where $R \in \mathbb{R}^{n \times q}$, $A_0 \in \mathbb{R}^{q \times n}$, and $\text{rank}(A_0) = q$. Define $A_{01} \in \mathbb{R}^{n-q \times n}$, $\text{rank}(A_{01}) = n - q$, and $A_0 A_{01}^T = 0$. Then, performing the linear transformation

$$z = Tx, \quad (2.5)$$

$$T = \begin{bmatrix} A_{01} \\ [A_0 A_0^T]^{-1} A_0 \end{bmatrix},$$

the system (2.1) can be transformed into

$$\begin{aligned} \dot{z} &= (TAT^{-1})z + TBu, \\ y &= (AT^{-1})z + Bu, \end{aligned} \quad (2.6)$$

where

$$T^{-1} = \begin{bmatrix} A_{01}^T [A_{01} A_{01}^T]^{-1} A_0^T \end{bmatrix}. \quad (2.7)$$

From (2.4)–(2.7) note that

$$AT^{-1} = RA_0 \begin{bmatrix} A_{01}^T [A_{01} A_{01}^T]^{-1} A_0^T \end{bmatrix} = \begin{bmatrix} 0 & RA_0 A_0^T \end{bmatrix}. \quad (2.8)$$

Thus, from (2.6)–(2.8) and defining $z^T = [z_a^T z_b^T]$, $z_a \in \mathbb{R}^{n-q}$, and $z_b \in \mathbb{R}^q$, one has

$$y = AT^{-1}z + Bu = RA_0 A_0^T z_b + Bu. \quad (2.9)$$

Now, from (2.4)–(2.7) note that

$$\begin{aligned} \dot{z} &= \begin{bmatrix} \dot{z}_a \\ \dot{z}_b \end{bmatrix} \\ &= \begin{bmatrix} A_{01} \\ [A_0 A_0^T]^{-1} A_0 \end{bmatrix} RA_0 \begin{bmatrix} A_{01} \\ [A_0 A_0^T]^{-1} A_0 \end{bmatrix}^T \begin{bmatrix} z_a \\ z_b \end{bmatrix} + \begin{bmatrix} A_{01} \\ [A_0 A_0^T]^{-1} A_0 \end{bmatrix} Bu \\ &= \begin{bmatrix} 0 & A_{01} RA_0 A_0^T \\ 0 & [A_0 A_0^T]^{-1} A_0 RA_0 A_0^T \end{bmatrix} \begin{bmatrix} z_a \\ z_b \end{bmatrix} + \begin{bmatrix} A_{01} B \\ [A_0 A_0^T]^{-1} A_0 B \end{bmatrix} u. \end{aligned} \quad (2.10)$$

Hence, observe that z_a cannot be detected from the output y , because z_a is not connected to y in (2.9) and also to \dot{z}_b in (2.10). Therefore the subsystem with state vector z_a is not observable. Now, from (2.10) it follows that

$$\dot{z}_a = A_{01} RA_0 A_0^T z_b + A_{01} Bu, \quad (2.11)$$

and this system has $n - q$ poles at $s = 0$. This completes the proof of Lemma 2.2. \square

The next lemma addresses the stabilization of system (2.1).

Lemma 2.3. *If $\det(A) = 0$, the system (2.1) cannot be stabilizable by using an output feedback.*

Proof. From Lemma 2.2, if $\det(A) = 0$ and $\text{rank}(A) = q < n$, then the system (2.1) is unobservable and the unobservable part has $n - q$ poles in $s = 0$. Thus, the unobservable part is not connected to the output and it is not possible to change its poles by using an output feedback. Therefore, the stabilization with an arbitrary output feedback is not possible. The lemma is proved. \square

3. Disturbances Rejection with State-Derivative Feedback

Results on the rejection of constant disturbances, added to the input of the plant (2.1), considering the state-derivative feedback are presented. Initially, the next lemma shows that plant (2.1) has at least one transmission zero at $s = 0$ if $\det(A) \neq 0$.

Lemma 3.1. *If $\det(A) \neq 0$, then the system (2.1) has at least one transmission zero at $s = 0$.*

Proof. Consider the system (2.1), given by

$$\begin{aligned}\dot{x}(t) &= Ax(t) + Bu(t), \\ y(t) &= \dot{x}(t).\end{aligned}\tag{3.1}$$

Applying the Laplace transform and considering the initial conditions equal to zero, then

$$\begin{aligned}sX(s) &= AX(s) + BU(s), \\ sX(s) - AX(s) &= BU(s), \\ (sI - A)X(s) &= BU(s), \\ X(s) &= (sI - A)^{-1}BU(s), \\ Y(s) &= sX(s).\end{aligned}\tag{3.2}$$

From (3.2) it follows that

$$Y(s) = s(sI - A)^{-1}BU(s).\tag{3.3}$$

Thus, supposing that $\det(A) \neq 0$, then A^{-1} can be calculated and

$$s(sI - A)^{-1}B \Big|_{s=0} = -sA^{-1}B \Big|_{s=0} = 0.\tag{3.4}$$

This completes the proof of the existence of transmission zeros at $s = 0$. \square

The existence of transmission zeros at $s = 0$, as demonstrated in Lemma 3.1, is a problem in the rejection of constant disturbances added to the plant input with a state-derivative feedback controller. Lemma 3.2 illustrates this fact.

Lemma 3.2. Consider the plant, with input u and output y ,

$$\begin{aligned}\dot{x}(t) &= Ax(t) + B(u(t) + \xi), \\ y(t) &= \dot{x}(t) = Ax(t) + B(u(t) + \xi),\end{aligned}\tag{3.5}$$

where $x(t) \in \mathbb{R}^n$, $u(t)$ and $\xi \in \mathbb{R}^m$, ξ is an unknown but constant disturbance, and the state-derivative controller

$$u(t) = -K\dot{x}(t), \quad \det(I + BK) \neq 0.\tag{3.6}$$

Suppose that $\det(A) \neq 0$ and the equilibrium point $x_e = -A^{-1}B\xi$ of the controlled system (3.5) and (3.6) is globally asymptotically stable. Then, $x(\infty)$ is independent of the controller gain K and is given by

$$x(\infty) = \lim_{t \rightarrow \infty} x(t) = -A^{-1}B\xi.\tag{3.7}$$

Proof. From (3.5) and (3.6) note that

$$\begin{aligned}\dot{x}(t) &= Ax(t) + B(-K\dot{x}(t) + \xi), \\ (I + BK)\dot{x}(t) &= Ax(t) + B\xi, \\ \dot{x}(t) &= (I + BK)^{-1}Ax(t) + (I + BK)^{-1}B\xi.\end{aligned}\tag{3.8}$$

Applying the Laplace transform in (3.8), observe that

$$\begin{aligned}sX(s) - x(0) &= (I + BK)^{-1}AX(s) + (I + BK)^{-1}B\xi s^{-1}, \\ X(s) &= \left(sI - (I + BK)^{-1}A\right)^{-1} \left((I + BK)^{-1}B\xi s^{-1} + x(0)\right).\end{aligned}\tag{3.9}$$

Thus, considering that the equilibrium point x_e of (3.5) and (3.6) is globally asymptotically stable, from the final value theorem in [1] it follows that

$$\begin{aligned}x(\infty) &= \lim_{s \rightarrow 0} sX(s) = \lim_{s \rightarrow 0} s \left(sI - (I + BK)^{-1}A\right)^{-1} (I + BK)^{-1}B\xi s^{-1} \\ &= -A^{-1}(I + BK)(I + BK)^{-1}B\xi = -A^{-1}B\xi.\end{aligned}\tag{3.10}$$

This establishes the lemma. \square

Lemma 3.2 shows that $x(\infty)$ given in (3.7) is independent of the state-derivative matrix K defined in (3.6). This fact illustrates the difficulty to attenuate the influence of ξ in $x(\infty)$ in controlled systems with state-derivative feedback, for instance, given by (3.5) and (3.6).

Fortunately, the main application of derivative feedback is in control of vibrations in mechanical systems, where in general the disturbances have a mean value equal to zero.

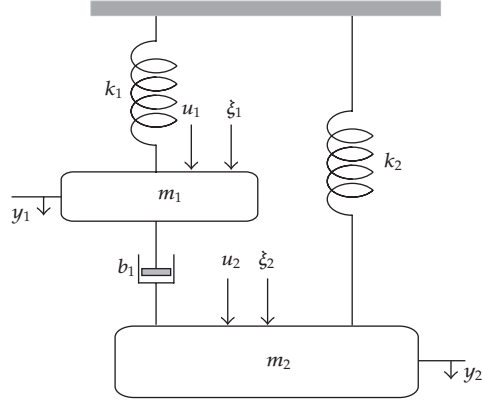

Figure 1: Multivariable (MI) mass-spring system with damping.

4. Example

Consider the mass-spring system with damping studied in [24] and shown in Figure 1. In this example, the idea was to illustrate the proposed results in Lemma 3.2. This system is a simple model of a controlled vibration absorber, in the sense of reducing the oscillations of the masses m_1 and m_2 . The coefficients of elasticity of the springs are k_1 and k_2 and b_1 is the damping coefficient. In this case, the model contains two control inputs, $u_1(t)$ and $u_2(t)$, and two unknown but constant disturbances, ξ_1 and ξ_2 . This system is described by the following equations [6]:

$$\begin{aligned} m_1 \ddot{y}_1(t) + b_1(\dot{y}_1(t) - \dot{y}_2(t)) + k_1 y_1(t) &= u_1(t) + \xi_1, \\ m_2 \ddot{y}_2(t) + b_1(\dot{y}_2(t) - \dot{y}_1(t)) + k_2 y_2(t) &= u_2(t) + \xi_2. \end{aligned} \quad (4.1)$$

The state-space form of the mechanical system in Figure 1 can be represented by (3.5), considering as state variables $x(t) = [x_1(t) \ x_2(t) \ x_3(t) \ x_4(t)]^T$, where $x_1(t) = y_1(t)$, $x_2(t) = \dot{y}_1(t)$, $x_3(t) = y_2(t)$, $x_4(t) = \dot{y}_2(t)$, $u(t) = [u_1(t) \ u_2(t)]^T$, $\xi = [\xi_1 \ \xi_2]^T$,

$$A = \begin{bmatrix} 0 & 1 & 0 & 0 \\ \frac{-k_1}{m_1} & \frac{-b_1}{m_1} & 0 & \frac{b_1}{m_1} \\ 0 & 0 & 0 & 1 \\ 0 & \frac{b_1}{m_2} & \frac{-k_2}{m_2} & \frac{-b_1}{m_2} \end{bmatrix}, \quad B = \begin{bmatrix} 0 & 0 \\ \frac{1}{m_1} & 0 \\ 0 & 0 \\ 0 & \frac{1}{m_2} \end{bmatrix}. \quad (4.2)$$

Consider the state-derivative feedback control law (3.6). Then, the controlled system (3.5), (3.6), and (4.2) can be described by (3.8).

For the design of a suitable gain K using the results from Theorem 1 in [24], first define the following matrices:

$$A_n = A^{-1}, \quad B_n = -A^{-1}B. \quad (4.3)$$

Then, from (4.2), (4.3) and $m_1 = 10$ kg, $m_2 = 30$ kg, $k_1 = 2.5$ kN/m, $k_2 = 1.5$ kN/m, and $b_1 = 30$ Ns/m, one has

$$A_n = \begin{bmatrix} -0.0120 & -0.0040 & 0.0120 & 0 \\ 1.0000 & 0 & 0 & 0 \\ 0.0200 & 0 & -0.0200 & -0.0200 \\ 0 & 0 & 1.0000 & 0 \end{bmatrix}, \quad (4.4)$$

$$B_n = \begin{bmatrix} 0.4000 \times 10^{-3} & 0 \\ 0 & 0 \\ 0 & 0.6667 \times 10^{-3} \\ 0 & 0 \end{bmatrix}.$$

Note that (A_n, B_n) is controllable.

The idea of Theorem 1 in [24] was the design of state-derivative feedback gains, using a designed state feedback gain.

Thus, consider the pole placement as design technique and the following closed-loop poles for the controlled system (3.8):

$$\lambda_1 = -10, \quad \lambda_2 = -15, \quad \lambda_{3,4} = -2 \pm 10i. \quad (4.5)$$

Now, the following closed-loop system is defined [24]:

$$\begin{aligned} \dot{x}_n(t) &= A_n x(t) + B_n u_n(t), \\ u_n(t) &= -K x_n(t). \end{aligned} \quad (4.6)$$

From (4.6) it follows that

$$\dot{x}_n(t) = (A_n - B_n K) x_n(t). \quad (4.7)$$

Then, design the gain K such that the system (4.7) has poles equal to λ_1^{-1} , λ_2^{-1} , λ_3^{-1} , and λ_4^{-1} [24].

Table 1: Disturbances and controller gains of the simulated system.

Time (s)	ξ_1 [N]	ξ_2 [N]	K	$x_e = -A^{-1}B[\xi_1 \ \xi_2]^T$
0 † 20	0	0	K_0	$[0 \ 0 \ 0 \ 0]^T$
20 † 40	300	0	K_0	$[0.12 \ 0 \ 0 \ 0]^T$
40 † 60	0	-300	K_0	$[0 \ 0 \ -0.2 \ 0]^T$
60 † 80	300	0	0	$[0.12 \ 0 \ 0 \ 0]^T$
80 † 100	0	-300	0	$[0 \ 0 \ -0.2 \ 0]^T$
100 † 120	0	0	0	$[0 \ 0 \ 0 \ 0]^T$

Now, from (4.3) and $\lambda_i \neq 0, i = 1, 2, 3, 4$, note that

$$(A_n - B_n K)^{-1} = (A^{-1} + A^{-1} B K)^{-1} = (A^{-1} (I + B K))^{-1} = (I + B K)^{-1} A, \quad (4.8)$$

and from (4.7) and Lemma 1 in [24], $\lambda_1, \lambda_2, \lambda_3$, and λ_4 are the eigenvalues of $(I + B K)^{-1} A$. Therefore, $\lambda_1, \lambda_2, \lambda_3$, and λ_4 are also the poles of the controlled system (3.5), (3.6), and (4.2), described in (3.8).

From Theorem 1 in [24], the poles for the new closed-loop system with state feedback (4.7), with A_n and B_n given in (4.4), are the following:

$$\lambda_1^{-1} = -0.1000, \quad \lambda_2^{-1} = -0.0667, \quad \lambda_{3,4}^{-1} = -0.0192 \pm 0.0962i. \quad (4.9)$$

Thus, with these parameters, one can easily obtain, through the command *place* of MATLAB, the feedback gain matrix K_0 below:

$$K_0 = \begin{bmatrix} 178.9532 & -6.4647 & 323.3542 & 19.8478 \\ -79.6370 & -11.4321 & 152.3204 & -26.1863 \end{bmatrix}, \quad (4.10)$$

such that, for $K = K_0$, the poles of (4.7) are equal to $\lambda_1^{-1}, \lambda_2^{-1}, \lambda_3^{-1}$, and λ_4^{-1} .

Note that, for $K = 0$, the poles of the system given in (3.8) are equal to

$$\lambda_{1,2} = -0.14962 \pm 15.6198i, \quad \lambda_{3,4} = -0.5038 \pm 7.1074i. \quad (4.11)$$

Table 1 above shows the values of ξ_1, ξ_2 , and K in the time intervals, adopted in a digital simulation of the controlled system (3.8) and (4.2).

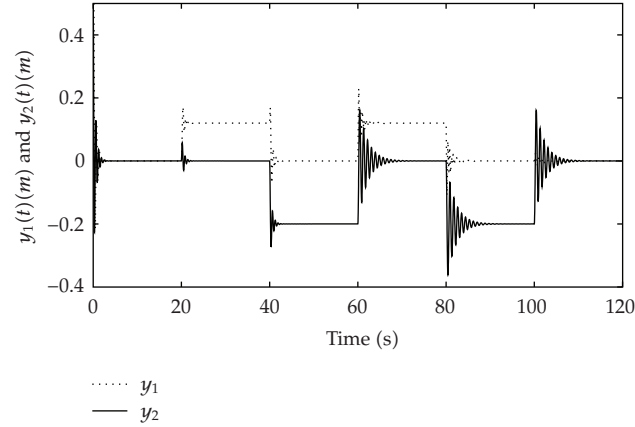

Figure 2: Transient response of the controlled system (3.8) and (4.2), with $x(0) = [0.1 \ 0 \ 0.1 \ 0]^T$, disturbances and gains given in Table 1.

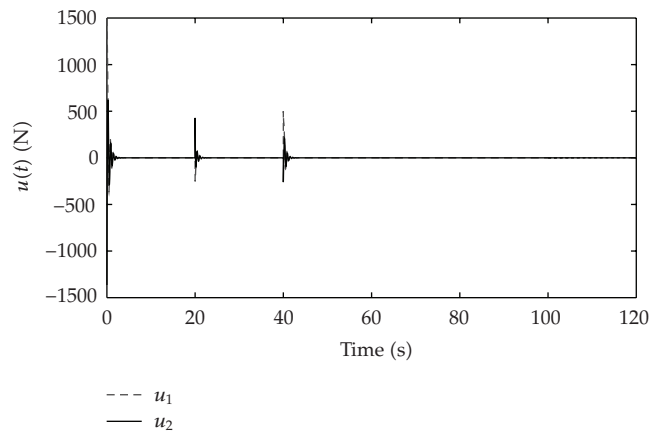

Figure 3: Control inputs of the controlled system (3.8) and (4.2), with $x(0) = [0.1 \ 0 \ 0.1 \ 0]^T$, disturbances and gains given in Table 1.

Figures 2 and 3 display the simulation results of the controlled system (3.5), (3.6), and (4.2), which can be given by (3.8), with the initial condition

$$x(0) = \begin{bmatrix} 0.1 \\ 0 \\ 0.1 \\ 0 \end{bmatrix} \quad (4.12)$$

and the conditions described in Table 1.

For $\xi = [\xi_1 \ \xi_2]^T = [300 \ 0]^T$, at $t \in [20, 40)$ and $t \in [60, 80)$, from Lemma 3.2, (3.7), and (4.2), one has

$$x(\infty) = \lim_{t \rightarrow \infty} x(t) = -A^{-1}B\xi = \begin{bmatrix} 0.12 \\ 0 \\ 0 \\ 0 \end{bmatrix} \quad (4.13)$$

and for $\xi = [\xi_1 \ \xi_2]^T = [0 \ -300]^T$, at $t \in [40, 60)$ and $t \in [80, 100)$ then from Lemma 3.2, (3.7) and (4.2) one has

$$x(\infty) = \lim_{t \rightarrow \infty} x(t) = -A^{-1}B\xi = \begin{bmatrix} 0 \\ 0 \\ -0.2 \\ 0 \end{bmatrix}. \quad (4.14)$$

Note that Figure 2 illustrates these results.

5. Conclusions

The paper presented some conclusive results about the observability, stabilizability, and disturbance rejection of linear time-invariant plants with output equal to the state-derivative vector. There exist many results in the literature about these subjects, for multivariable linear time-invariant systems [23]. However, the authors did not find results for the special case where the plant output is the state-derivative vector. Thus, these results can be useful in the analysis and design of control systems with state-derivative feedback. Future researches in this subject include the analysis and control design of nonlinear state-derivative feedback.

Acknowledgments

The authors gratefully acknowledge the financial support by CAPES, FAPESP, and CNPq from Brazil.

References

- [1] K. Ogata, *Modern Control Engineering*, Prentice Hall, New York, NY, USA, 4th edition, 2002.
- [2] F. L. Lewis and V. L. Syrmos, "A geometric theory for derivative feedback," *IEEE Transactions on Automatic Control*, vol. 36, no. 9, pp. 1111–1116, 1991.
- [3] T. H.S. Abdelaziz and M. Valášek, "Pole-placement for SISO linear systems by state-derivative feedback," *IEE Proceedings: Control Theory and Applications*, vol. 151, no. 4, pp. 377–385, 2004.
- [4] Y. F. Duan, Y. Q. Ni, and J. M. Ko, "State-derivative feedback control of cable vibration using semiactive magnetorheological dampers," *Computer-Aided Civil and Infrastructure Engineering*, vol. 20, no. 6, pp. 431–449, 2005.

- [5] S.-K. Kwak, G. Washington, and R. K. Yedavalli, "Acceleration-based vibration control of distributed parameter systems using the "reciprocal state-space framework"," *Journal of Sound and Vibration*, vol. 251, no. 3, pp. 543–557, 2002.
- [6] R. Cardim, M. C. M. Teixeira, E. Assunção, and M. Covacic, "Design of state-derivative feedback controllers using a state feedback control design," in *Proceedings of the 3rd IFAC Symposium on System, Structure and Control*, vol. 1, pp. 135–141, Iguassu Falls, Brazil, 2007.
- [7] J. M. Araújo, A. C. Castro, and E. T. F. Santos, "Alocação de Pólos em Sistemas Lineares Invariantes no Tempo Utilizando Realimentação da Derivada de Estados e a Equação de Lyapunov," *Controle y Automacao*, vol. 20, no. 3, pp. 263–270, 2009 (Portuguese).
- [8] T. H. S. Abdelaziz, "Optimal control using derivative feedback for linear systems," *Proceedings of the Institution of Mechanical Engineers. Part I: Journal of Systems and Control Engineering*, vol. 224, no. 2, pp. 185–202, 2010.
- [9] T. H. S. Abdelaziz, "Robust pole assignment for linear time-invariant systems using state-derivative feedback," *Proceedings of the Institution of Mechanical Engineers. Part I: Journal of Systems and Control Engineering*, vol. 223, no. 2, pp. 187–199, 2009.
- [10] T. H. S. Abdelaziz, "Pole assignment by state-derivative feedback for single-input linear systems," *Proceedings of the Institution of Mechanical Engineers. Part I: Journal of Systems and Control Engineering*, vol. 221, no. 7, pp. 991–1000, 2007.
- [11] T. H. S. Abdelaziz and M. Valášek, "Direct algorithm for pole placement by state-derivative feedback for multi-input linear systems—nonsingular case," *Kybernetika*, vol. 41, no. 5, pp. 637–660, 2005.
- [12] T. H. S. Abdelaziz and M. Valášek, "Eigenstructure assignment by proportional-plus-derivative feedback for second-order linear control systems," *Kybernetika*, vol. 41, no. 5, pp. 661–676, 2005.
- [13] F. A. Faria, E. Assunção, M. C. M. Teixeira, R. Cardim, and N. A. P. da Silva, "Robust state-derivative pole placement LMI-based designs for linear systems," *International Journal of Control*, vol. 82, no. 1, pp. 1–12, 2009.
- [14] R. Cardim, M. C. M. Teixeira, F. Faria, and E. Assunção, "LMI-based digital redesign of linear time-invariant systems with state-derivative feedback," in *Proceedings of IEEE Multi-Conference on Systems and Control*, vol. 1, pp. 745–749, Saint Petersburg, Russia, 2009.
- [15] S. K. Kwak, G. Washington, and R. K. Yedavalli, "Acceleration feedback-based active and passive vibration control of landing gear components," *Journal of Aerospace Engineering*, vol. 15, no. 1, pp. 1–9, 2002.
- [16] E. Reithmeier and G. Leitmann, "Robust vibration control of dynamical systems based on the derivative of the state," *Archive of Applied Mechanics*, vol. 72, no. 11-12, pp. 856–864, 2003.
- [17] E. Assunção, M. C. M. Teixeira, F. A. Faria, N. A. P. da Silva, and R. Cardim, "Robust state-derivative feedback LMI-based designs for multivariable linear systems," *International Journal of Control*, vol. 80, no. 8, pp. 1260–1270, 2007.
- [18] F. A. Faria, E. Assunção, M. C. M. Teixeira, and R. Cardim, "Robust state-derivative feedback LMI-based designs for linear descriptor systems," *Mathematical Problems in Engineering*, vol. 2010, Article ID 927362, 15 pages, 2010.
- [19] F. A. Faria, E. Assunção, and M. C. M. Teixeira, "Realimentação da derivada dos estados em sistemas multivariáveis lineares usando LMIs," *Controle y Automacao*, vol. 20, no. 1, pp. 83–93, 2009.
- [20] J. M. Araújo, A. C. Castro, F. G. S. Silva, E. T. F. Santos, and C. E. T. Dórea, "Comparative study on state feedback and state-derivative feedback in linear time invariant systems," in *Proceedings of the 3rd IFAC Symposium on System, Structure and Control*, vol. 3, Iguassu Falls, Brazil, 2007, article 119.
- [21] M. R. Moreira, E. I. M. Junior, T. T. Esteves et al., "Estabilidade e rejeição de distúrbios com realimentação da derivada do vetor de estados," in *XVIII Congresso Brasileiro de Automática*, pp. 5230–5233, Bonito-MS, Brazil, 2010.
- [22] W. Michiels, T. Vyhliđal, H. Huijberts, and H. Nijmeijer, "Stabilizability and stability robustness of state derivative feedback controllers," *SIAM Journal on Control and Optimization*, vol. 47, no. 6, pp. 3100–3117, 2008.
- [23] C. T. Chen, *Linear System Theory and Design*, Oxford University Press, New York, NY, USA, 2nd edition, 1999.
- [24] R. Cardim, M. C. M. Teixeira, E. Assunção, and F. A. Faria, "Control designs for linear systems using state-derivative feedback," in *Systems, Structure and Control*, P. Husek, Ed., pp. 1–28, In-Teh, 2008.



Hindawi

Submit your manuscripts at
<http://www.hindawi.com>

