



UNIVERSITÀ DEGLI STUDI DI PADOVA

FACOLTA' DI INGEGNERIA

Corso di laurea Magistrale in Ingegneria Energetica

Tesi di Laurea Magistrale

**“Ventilative Cooling to Avoid Overheating
in
Low Energy Buildings”**

RELATORI:

Prof. Michele De Carli

Phd Angela Simone

Prof. Bjarne W.Olesen

LAUREANDA:

Marta Avantaggiato

Questo lavoro di Tesi è stato svolto presso:

**INTERNATIONAL CENTER FOR INDOOR ENVIRONMENT AND
ENERGY**

Technical University of Denmark



ANNO ACCADEMICO 2013/2014

PREFACE

This Master thesis is the results of a work carried out between February and November 2013 at the International Centre for Indoor Environment and Energy, Technical University of Denmark.

The first part of literature review has helped to focus on the problems faced by the previous studies on reducing building energy demand in accordance with the European Directive [1]. At the same time it has also supported a general overview of passive cooling strategies methods and systems exploited for residential and office buildings.

In the last years significant efforts were spent to reduce energy use in buildings from demands, consumption and supply needs. The new building's concept often results, due to the requirement for low energy consumption, on overlooking the indoor environmental quality for low energy actions. One of the actions is the increasing of building's insulation level, which has brought to a higher cooling demand and sometimes, to underestimate the indoor environmental quality needs. In particular, during the design of low energy building in cold climates, with wider glazed surfaces, it led discomfort problems such as *overheating*, issue that can be experienced by the building's users not only in summer but also in midseason.

These considerations have shaped the motivation of this Master thesis work. Through dynamic simulations, different passive and/or active cooling techniques have been tested for a low energy residential building in Copenhagen climate. The aim was to check if the speculated solutions can guarantee a good indoor environment when energy cooling need is reduced and/or nullified.

The final report can be mainly divided in four parts:

- summary of available studies,
- building model description and used methodology,
- main important results and discussions, and
- conclusions and suggestions for further continuation of this initiated work.

More detailed results are collected in Appendixs.

Thanks are due to dr. Angela Simone, researcher at ICIEE, and to Prof. Bjarne W. Olesen head of ICIEE center at the department of civil engineering at DTU for the advices and guidance during the entire project period

PREFAZIONE

La presente Tesi è il frutto del lavoro di ricerca condotto tra febbraio e novembre 2013 presso l'International Centre for Indoor Environment and Energy, Technical University of Denmark.

L'iniziale lavoro di revisione della letteratura ha permesso di comprendere i problemi riscontrati nei precedenti studi di ricerca e allo stesso tempo, ha permesso di avere una panoramica generale sullo sviluppo dei sistemi e metodi per lo sfruttamento di tecnologie passive al servizio di costruzioni civili e terziarie a basso consumo energetico.

Negli ultimi anni sono stati fatti notevoli sforzi volti a ridurre il consumo energetico degli edifici, sia dal lato della domanda sia da quello della distribuzione. Questo ha fatto sì che un nuovo tipo di edifici si sia sviluppato in cui spesso, la sempre più intensa attenzione al ridotto consumo energetico ha favorito l'adozione di misure energeticamente efficienti sottovalutando la qualità dell'ambiente interno. Una di queste misure, incrementare il livello di isolamento della struttura, ha portato ad avere un aumento della domanda di raffrescamento, molte volte sottovalutata in fase di progetto specialmente per i climi freddi, che ha fatto nascere problemi di discomfort come ad esempio overheating, in tali edifici a ridotto consumo energetico. Questo inconveniente, come provato su edifici reali, si verifica non solo in estate ma anche nelle mezze stagioni.

Tutte queste considerazioni hanno dato forma alle motivazioni di questo lavoro di tesi. Attraverso simulazioni dinamiche, sono stati analizzati diversi sistemi di raffrescamento passivo e/o attivo per un low energy building ad uso residenziale testato per il clima di Copenaghen. Lo scopo è stato quello di verificare se queste soluzioni sono in grado di garantire una buona qualità dell'ambiente interno sempre tenendo in considerazione l'obiettivo del ridurre i consumi energetici.

La relazione finale può essere divisa in quattro parti:

- i risultati dei recenti studi,
- la descrizione del modello e della metodologia usata,
- l'analisi dei principali risultati e
- le conclusioni finali.

Nelle appendici sono poi raccolti alcuni risultati più dettagliati.

Si ringraziano Angela Simone, ricercatrice presso l'ICIEE e il Professor Bjarne W. Olesen, direttore dell'ICIEE presso il dipartimento di Ingegneria Civile della DTU, per gli utili consigli e la guida offerta durante l'intero progetto.

Un ringraziamento ai Professori Michele De Carli e Roberto Zecchin per l'opportunità concessa di svolgere la tesi all'estero.

1. Table of Contents

1. INTRODUCTION	1
2. NEARLY ZERO ENERGY BUILDING (NZEB)	3
2.1 ENGINEERING CHALLENGE	3
2.2 PASSIVE HOUSE	8
2.3 OVERHEATING IN NZEB: AN UNPLEASANT PROBLEM.....	10
2.3.1 Thermal control.....	11
2.3.2 Natural cooling	14
2.4 REINVENTING THE PAST	20
3. BUILDING MODEL AND METHODOLOGY	23
3.1 BUILDING CHARACTERISTICS	23
3.2 WINDOWS, DOORS AND SOLAR SHADING	26
3.3 MECHANICAL VENTILATION	30
3.4 HEATING AND COOLING SYSTEM	31
3.5 METHODOLOGY	32
4. BUILDING BEHAVIOR	37
4.1 CASE STUDIES	39
4.2 RESULTS	41
4.2.1 Energy demand	41
4.2.2 Thermal comfort	43
4.2.3 Indoor air quality	50
4.3 EFFECT OF BEHAVIOR VENTILATION	52
4.4 DOES THE MISSING COOLING SYSTEM IMPACT ON THERMAL COMFORT?.....	54
5. TOWARD NEARLY ZERO ENERGY BUILDINGS	57
5.1 RESULTS	61
5.1.1 Energy Demand	61
5.1.2 Thermal Comfort	62
5.1.3 Indoor Air Quality	69
5.2 EFFECT OF BEHAVIOR VENTILATION.....	70
6. RESULTS COMPARISON OF TWO BUILDING STRUCTURES.....	71
6.1 ENERGY DEMAND	71
6.2 THERMAL COMFORT.....	73

6.3	INDOOR AIR QUALITY	78
6.4	EFFECT OF BEHAVIOR VENTILATION	79
7.	NIGHT VENTILATION: A COMPARISON BETWEEN MECHANICAL AND NATURAL	81
7.1	VARIATIONS OF NATURAL NIGHT VENTILATION MODEL	82
7.2	NEW AHU DESIGN: A VARIABLE AIR VOLUME SOLUTION	83
7.3	RESULTS.....	84
7.4	QUALITATIVE ANALYSIS OF WINDOWS OPENING WIDTH DURING NIGHT.....	88
7.5	SHADING AND DAYLIGHT ANALYSIS	90
7.6	EFFECT OF AUTOMATIC CONTROL OF OPEN WINDOWS ON INDOOR ENVIRONMENT	93
7.6.1	Windows opening ranges	94
7.6.2	Air velocity analysis	96
7.6.3	Energy demand, thermal comfort and IAQ.....	98
8.	EFFECT OF SCANDINAVIAN BEHAVIOR ON ENERGY DEMAND.	101
8.1	RESULTS.....	102
9.	CONCLUSIONS	107
9.1	PASSIVE STRATEGIES ANALYSES.....	107
9.2	NATURAL NIGHT VENTILATION VS MECHANICAL NIGHT VENTILATION	108
9.3	FURTHER CONTINUATION OF THE STUDY	108
10.	REFERENCES.....	111
	APPENDIX A	115
	APPENDIX B.....	117
	APPENDIX C	121
	APPENDIX D	125
	APPENDIX E.....	131
	APPENDIX F.....	135
	APPENDIX G	138

List of Figures

FIGURE 1 SCHEME OF ENERGY FLUX	4
FIGURE 2 PASSIVE HOUSE ENERGY SAVING COMPARED WITH LOW ENERGY HOUSE [8].....	8
FIGURE 3 EVOLUTION OF PASSIVE HOUSE BETWEEN 2001 AND 2012 [11]	9
FIGURE 4 MEASURED INDOOR TEMPERATURES OF THE TWO BUILDINGS IN SUMMER SEASON [18] ..	11
FIGURE 5 DIFFERENT SOLUTIONS FOR EXTERNAL SOLAR SHADING [14].....	13
FIGURE 6 HENDON MAGISTRATE COURTS, FIXED SOLAR SHADING TIMBER LOUVERS [15].....	13
FIGURE 7 STRUCTURE OF A DOUBLE GLAZING	14
FIGURE 8 EFFECT OF AIR SPEED AND MEAN RADIANT TEMPERATURE OF THE ENCLOSURE ON THE THERMAL COMFORT [24] ..	15
FIGURE 9 EXAMPLE OF SINGLE-SIDE VENTILATION. IT IS EFFECTIVE ONLY WHEN $W=2,5 H$ [29].....	16
FIGURE 10 EXAMPLE OF CROSS VENTILATION. IT IS EFFECTIVE ONLY WHEN $W=5 H$ [29]	16
FIGURE 11 EXAMPLE OF STACK VENTILATION [30]	17
FIGURE 12 REDUCTION OF OVERHEATING HOURS DUE TO THE USE OF NATURAL VENTILATION [32]	18
FIGURE 13 MAP OF MEAN CLIMATIC COOLING POTENTIAL (KH/NIGHT) IN JULY [33].....	19
FIGURE 14 LAGRASTA’S HYPOGEUM, CANOSA DI PUGLIA, ITALY	21
FIGURE 15 TYPICAL DOME CEILING OF SOUTHERN APULIA	21
FIGURE 16 INTERNAL COURTYARD (LEFT), DOOR WITH SMALL OPENINGS FOR NATURAL VENTILATION (MIDDLE), CRACKS FOR AIR RECIRCULATION (RIGHT).....	22
FIGURE 17 VISUAL REPRESENTATION OF THE MODEL FROM VELUX ENERGY AND INDOOR CLIMATE VISUALIZER.	23
FIGURE 18 ORIENTATION OF NUMBERED WINDOW IN THE BUILDING-PLAN	27
FIGURE 19 CONTROL STRATEGY FOR THE SUNSHADE (LEFT) AND EXAMPLE OF VELUX AWNING BLIND (RIGHT)	28
FIGURE 20 CONTROL STRATEGIES FOR WINDOW OPENING (SCREEN DUMP FROM VELUX EIC).....	29
FIGURE 21 AIRING SCHEDULE (LEFT) AND NIGHT SCHEDULE (RIGHT) (SCREEN DUMP FROM VELUX EIC)	30
FIGURE 22 AIR HANDLING UNIT (SCREEN DUMP FROM VELUX)	30
FIGURE 23 CORRELATION BETWEEN AIR VELOCITIES AND OFFSET INCREASED TEMPERATURES [35] ...	35
FIGURE 24 MONTHLY OUTSIDE AIR TEMPERATURES IN COPENHAGEN	37
FIGURE 25 T_o AND T_a ANNUAL TREND OF FIRST BASIC SIMULATED MODEL.....	38
FIGURE 26 DAILY TEMPERATURE TRENDS OF THE FIRST SIMULATED BUILDING MODEL FROM SATURDAY MAY 4 TH TO TUESDAY MAY 7 TH . ..	39
FIGURE 27 PRIMARY ENERGY DEMAND FOR M_HC MODEL	40
FIGURE 28 ANNUAL TEMPERATURES TREND FOR M_HC MODEL.....	40
FIGURE 29 COOLING DEMAND WHEN PASSIVE STRATEGIES ARE USED (PLUS) OR NOT (M_HC)	41
FIGURE 30 TOTAL ENERGY DEMAND FOR THE CASE STUDIES WITH AND WITHOUT HRV	42
FIGURE 31 DISTRIBUTION OF THE TOTAL ENERGY DEMAND BETWEEN THE THREE SYSTEMS.....	43
FIGURE 32 ANNUAL INDOORS TEMPERATURE TRENDS FOR THE CASE STUDIES M_HC, M_HC_S, M_HC_NA AND M_HC_SNA.	44
FIGURE 33 MONTHLY TEMPERATURE TRENDS FOR M_HC_NA AND M_HC_SNA MODELS IN SUMMER...	46
FIGURE 34 THERMAL COMFORT THROUGHOUT THE YEAR VALUATED ACCORDING TO THE EN 15251 NON-ADAPTIVE MODEL	46
FIGURE 35 THERMAL PERFORMANCE DURING THE NIGHT VENTILATION PERIOD ACCORDING TO EN 15251 NON-ADAPTIVE MODEL	47
FIGURE 36 PERCENTAGE OF HOURS IN WHICH THE TEMPERATURE IS OVER DIFFERENT THRESHOLDS DURING THE OCCUPANCY TIME.....	48

FIGURE 37 TEMPERATURES TRENDS OF M_HC_NA, M_HC_S AND M_HC_SNA MODELS DURING THE TWO WARMEST WEEK OF THE YEAR (FROM JULY 29 TH TO AUGUST 11 TH)	49
FIGURE 38 TEMPERATURES TRENDS OF M_HC_NA, M_HC_S AND M_HC_SNA MODELS DURING THE TWO WEEKS IN THE MID-SEASON; ONE FROM APRIL 29 TH TO MAY 5 TH AND THE OTHER ONE FROM SEPTEMBER 9 TH TO SEPTEMBER 15 TH	50
FIGURE 39 IAQ FOR THE WHOLE YEAR EVALUATED ACCORDING TO THE EN 15251 FOR THE EIGHT MODELS	51
FIGURE 40 IAQ DURING THE NATURAL NIGHT VENTILATION PERIOD	51
FIGURE 41 AIR CHANGE PER HOUR DIVIDED BETWEEN DAYTIME AND NIGHTTIME DURING THE NIGHT VENTILATION PERIOD	52
FIGURE 42 AIR CHANGE PER HOUR DIVIDED BETWEEN DAYTIME AND NIGHTTIME DURING THE NIGHT VENTILATION PERIOD	53
FIGURE 43 THERMAL COMFORT AMONG THE YEAR EVALUATED ACCORDING TO EN 15251	53
FIGURE 44 IAQ AMONG THE YEAR EVALUATED ACCORDING TO EN 15251	53
FIGURE 45 THERMAL COMFORT AMONG THE YEAR ACCORDING TO EN 15251	54
FIGURE 46 M_HC_SNA_HRV AND M_H_SNA_HRV OPERATIVE TEMPERATURE TENDENCIES DURING THE TWO WARMEST WEEKS OF THE YEAR	55
FIGURE 47 COMPARISON IN TERM OF ENERGY DEMAND FOR M_HC_SNA_HRV AND M_H_SNA_HRV MODELS	55
FIGURE 48 ANNUAL TEMPERATURE PROFILES WHEN NEITHER COOLING SYSTEM NOR PASSIVE STRATEGIES ARE APPLIED (M_H MODEL).	59
FIGURE 49 THERMAL COMFORT CATEGORIES ACCORDING TO EN 15251 FOR THE WHOLE YEAR AND FOR A PERIOD BETWEEN MAY 15 TH AND SEPTEMBER 15 TH (M_H MODEL)	59
FIGURE 50 ANNUAL TEMPERATURE TENDENCY WHEN THE ACTIVE COOLING SYSTEM IS WORKING (M_HC MODEL)	60
FIGURE 51 DISTRIBUTION OF ENERGY DEMAND IN TERM OF PRIMARY ENERGY	60
FIGURE 52 NEW COOLING DEMAND DUE TO THE PASSIVE STRATEGIES COMPARED WITH THE REFERENCE MODEL COOLING DEMAND	61
FIGURE 53 EFFECT OF THE HRV ON TOTAL ENERGY DEMAND FOR ALL CASE STUDIES	62
FIGURE 54 DISTRIBUTION OF THE TOTAL ENERGY DEMAND BETWEEN THE THREE SYSTEMS	62
FIGURE 55 ANNUAL TEMPERATURE TRENDS FOR THE CASE STUDIES M_HC, M_HC_S, M_HC_NA AND M_HC_SNA	64
FIGURE 56 ANNUAL OPERATIVE TEMPERATURES TRENDS	64
FIGURE 57 OPERATIVE TEMPERATURE TRENDS DURING THE TWO WARMEST WEEK OF THE YEAR (FROM JULY 29 TH TO AUGUST 11 TH)	65
FIGURE 58 THERMAL COMFORT THROUGHOUT THE YEAR EVALUATED ACCORDING TO EN 15251 NON-ADAPTIVE MODEL	66
FIGURE 59 THERMAL PERFORMANCE DURING THE NIGHT VENTILATION PERIOD ACCORDING TO EN 15251 NON-ADAPTIVE MODEL	66
FIGURE 60 WINDOWS SURFACE TEMPERATURES DURING THE WARMEST SUMMER DAYS M_HC_NA (UPPER) AND M_HC_SNA (LOWER)	67
FIGURE 61 PERCENTAGE OF HOURS IN WHICH THE TEMPERATURE IS OVER THE DIFFERENT THRESHOLD DURING THE OCCUPANCY TIME	68
FIGURE 62 AIR CHANGE PER HOUR DIVIDED BETWEEN DAYTIME AND NIGHTTIME DURING THE NIGHT VENTILATION PERIOD	69
FIGURE 63 AIR CHANGE PER HOUR DIVIDED BETWEEN DAYTIME AND NIGHTTIME DURING THE NIGHT VENTILATION PERIOD	70
FIGURE 64 THERMAL COMFORT AMONG THE YEAR EVALUATED ACCORDING TO EN 15251	70
FIGURE 65 IAQ AMONG THE YEAR EVALUATED ACCORDING TO EN 15251	70

FIGURE 66 TOTAL ENERGY DEMAND HISTOGRAM FOR ALL THE MODELS SEPARATED FOR THE TWO STRUCTURES	72
FIGURE 67 ENERGY DEMAND DIVIDED BY THE THREE SYSTEMS FOR M_HC_HRV AND M_HC_SNA_HRV MODELS FOR BOTH STRUCTURE A AND B.	73
FIGURE 68 WHOLE YEAR THERMAL COMFORT EVALUATED WITH EN 15251 NON-ADAPTIVE	74
FIGURE 69 NIGHT VENTILATION PERIOD THERMAL COMFORT EVALUATED WITH EN 15251 NON-ADAPTIVE MODEL DIVIDED PER CATEGORY (CATEGORY I-UPPER; CATEGORY II-MIDDLE; CATEGORY II-LOWER) ..	75
FIGURE 70 ANNUAL OPERATIVE TEMPERATURES TRENDS FOR THE TWO STRUCTURES. M_HC MODEL (UPPER) AND M_HC_SNA_HRV (LOWER)	76
FIGURE 71 COMPARISON OF OPERATIVE TEMPERATURES TRENDS FOR BOTH STRUCTURES AND FOR THE EXTREMES CASE STUDIES: M_HC (LEFT) AND M_HC_SNA_HRV(RIGHT)	76
FIGURE 72 COMPARISON BETWEEN THE TWO STRUCTURES IN TERM OF OVERHEATING HOURS DIVIDED FOR DIFFERENT THRESHOLDS (25°C, 26°C, 27°C AND 28° C).....	77
FIGURE 73 COMPARISON OF IAQ CATEGORY I DURING <i>NIGHT VENTILATION PERIOD</i>	78
FIGURE 74 COMPARISON BETWEEN THE TWO STRUCTURE IN TERM OF NIGHTTIME AIR CHANGE PER HOUR DURING NIGHT VENTILATION PERIOD	78
FIGURE 75 COMPARISON ABOUT THE NUMBERS OF OPENINGS	79
FIGURE 76 ENERGY DEMAND SYSTEMS FOR MNV (INCREASED ACH) AND NNV (WINDOWS OPENING).	84
FIGURE 77 TOTAL ENERGY DEMAND FOR THE ALTERNATIVE NIGHT VENTILATION STRATEGIES AND FOR THE REFERENCE MODEL	84
FIGURE 78 AIR CHANGES RATE TENDENCIES DURING THE PERIOD BETWEEN MAY 1 TH AND SEPTEMBER 30 TH	85
FIGURE 79 THERMAL COMFORT CATEGORIES ACCORDING TO EN 15251 FOR THE WHOLE YEAR (LEFT) AND FOR THE NIGHT VENTILATION PERIOD (RIGHT).	86
FIGURE 80 OPERATIVE TEMPERATURE TRENDS DURING DAY AUGUST 6 TH	86
FIGURE 81 SHADING OPERATION GRAPH FOR NATURAL NIGHT VENTILATION (UPPER) AND FOR MECHANICAL NIGHT VENTILATION (LOWER); EIGHT WINDOWS HAVE BEEN SELECTED, TWO FOR EACH DIRECTION.....	87
FIGURE 82 INDOOR AIR QUALITY CATEGORIES ACCORDING EN 15251 FOR THE WHOLE YEAR	87
FIGURE 83 PERCENTAGE OF WIDTH RANGE FOR WINDOWS INTERESTED IN THE NATURAL VENTILATION (UPPER) AND OPENING HOURS PER EACH WINDOW (LOWER)	89
FIGURE 84 OPENING WIDTH DIAGRAM DURING DAY AUGUST 3 TH (SCREEN DAMP FROM VELUX EIC)...	89
FIGURE 85 OPENING WIDTH DIAGRAM FOR GROUND FLOOR WINDOWS DURING THE NIGHT BETWEEN AUGUST 2 TH AND 3 TH	90
FIGURE 86 MONTHLY VALUES OF DAYLIGHT, ENERGY FOR VENTILATION AND FOR ARTIFICIAL LIGHTING	91
FIGURE 87 COMPARED RESULTS FOR TWO DIFFERENT SOLAR SHADING SET-POINTS.....	92
FIGURE 88 OPENING WIDTH PERCENTAGE RANGES NNV AT 7 A.M. (UPPER) AND 5 P.M. (LOWER)	94
FIGURE 89 OPENING WIDTH PERCENTAGE RANGES FOR MNV AT 7 A.M. (UPPER) AND 5 P.M. (LOWER)	95
FIGURE 90 OPERATIVE TEMPERATURES COMPARISON FOR DAY AUGUST 5 TH	95
FIGURE 91 OPENING PERCENTAGE DISTRIBUTION BETWEEN MORNING AND AFTERNOON FOR NNV(UPPER) AND MNV(LOWER)	96
FIGURE 92 TRENDS OF THE AVERAGE AND MAXIMUM HOURLY VALUES OF VELOCITY FOR MNV MODEL AT 7 A.M AND 5 P.M.....	97
FIGURE 93 TRENDS OF THE AVERAGE AND MAXIMUM HOURLY VALUES OF VELOCITY FOR NNV MODEL AT 7 A.M AND 5 P.M.....	97
FIGURE 94 THERMAL COMFORT (LEFT) AND IAQ (RIGHT) FOR BEHAVIOR VENTILATION.....	99

FIGURE 95 COPENHAGEN OUTSIDE AIR TEMPERATURE TREND FOR THE WHOLE YEAR	101
FIGURE 96 TOTAL ENERGY DEMAND FOR THE ALTERNATIVE NIGHT VENTILATION STRATEGIES AND FOR THE REFERENCE MODEL WHEN NO SOLAR SHADING IS USED	102
FIGURE 97 DISTRIBUTION OF ENERGY DEMAND WHEN NO SOLAR SHADING IS USED.	103
FIGURE 98 COMPARISON IN TERM OF TOTAL ENERGY DEMAND WHEN COOLING SET POINT AND USE OF SOLAR SHADING ARE USED IN DIFFERENT WAYS.	103
FIGURE 99 OPERATIVE TEMPERATURE TRENDS WITH 23°C COOLING SET-POINT AND WITHOUT SOLAR SHADING	104
FIGURE 100 TOTAL ENERGY DEMAND COMPARISON FOR THE TWO CASE STUDIES WITHOUT AND WITH SOLAR SHADING	104
FIGURE 101 TOTAL ENERGY DEMAND FOR DIFFERENT SET-POINTS COMBINATION	104
FIGURE 102 OPERATIVE TEMPERATURES PROFILES UNDER DIFFERENT SOLAR SHADING CONDITION NNV(UPPER) AND MNV(LOWER).....	105
FIGURE 103 SOLAR SHADING OPERATION WITH 23°C SET-POINT, NNV (UPPER) AND MNV (LOWER)	106
FIGURE 104 WIND VELOCITY (LEFT) AND WIND FREQUENCY (RIGHT) FOR THE CITY OF COPENHAGEN DURING THE NIGHT VENTILATION PERIOD	116
FIGURE 105 MONTHLY TEMPERATURES TEND FOR M_HC MODEL BY USING THE INCREASED INSULATED ENVELOPE.	118
FIGURE 106 MONTHLY TEMPERATURES TEND FOR M_HC_Na MODEL BY USING THE INCREASED INSULATED ENVELOPE.	120
FIGURE 107 HEATING ENERGY DEMAND	121
FIGURE 108 VENTILATION ENERGY DEMAND	122
FIGURE 109 COOLING ENERGY DEMAND.....	123
FIGURE 110 DAYTIME AND NIGHTTIME AVERAGE ACH VALUES	125
FIGURE 111 TOTAL ENERGY DEMAND FOR DIFFERENT MAXIMUM AIR FLOW	125
FIGURE 112 ANNUAL THERMAL COMFORT CATEGORIES FOR DIFFERENT MAXIMUM AIR FLOW	126
FIGURE 113 ACH NIGHTTIME TENDENCIES (BETWEEN MAY 1 TH AND SEPTEMBER 30 TH) DIFFERENT MAXIMUM AIR FLOW	127
FIGURE 114 TOTAL ENERGY DEMAND FOR DIFFERENT MAXIMUM ACH.....	128
FIGURE 115 THERMAL COMFORT CATEGORIES FOR ALL THE YEAR ACCORDING TO EN 15251	128
FIGURE 116 AIR CHANGE RATE GRAPHS	129
FIGURE 117 ANNUL OPERATIVE TEMPERATURE TRENDS FOR MNV (UPPER) AND FOR NNV (LOWER).	131
FIGURE 118 MONTHLY OPERATIVE TEMPERATURE TRENDS.....	133
FIGURE 119 OPERATIVE TEMPERATURE TRENDS FROM AUGUST 5 TH TO AUGUST 11 TH	133
FIGURE 120 PERCENTAGE WORKING HOURS	133
FIGURE 121 MONTHLY DAYLIGHT, VENTILATION DEMAND AND ARTIFICIAL LIGHTING VALUES FOR TWO DIFFERENT SOLAR	135
FIGURE 122 COMPARISON OF AVERAGE VALUES FOR TWO DIFFERENT SOLAR SHADING SET-POINTS.	137
FIGURE 123 SHADING OPERATION WHEN SET-POINT 26°C: MNV (UPPER) AND NNV (LOWER)	137
FIGURE 124 NUMBER OF HOUR IN WHICH THE EACH WINDOWS IS OPENED AT 7A.M. AND 5 P.M. FOR BOTH MODELS.	139
FIGURE 125 PMV AND PPD TRENDS BETWEEN APRIL AND OCTOBER FOR MNV MODEL (UPPER) AND FOR NNV MODEL (LOWER).....	139

List of Table

TABLE 1. DEFINITION OF LOW ENERGY BUILDINGS IN EUROPE [7].....	6
TABLE 2: SUMMARY OF INITIATIVES TOWARDS “NEARLY ZERO BUILDINGS” [2].....	7
TABLE 3: WALL STRATIGRAPHY FROM INSIDE TO OUTSIDE.....	24
TABLE 4: FLOOR STRATIGRAPHY FROM THE ROOM INSIDE SURFACE.....	24
TABLE 5: ROOF STRATIGRAPHY	24
TABLE 6: WINDOWS AND DOORS SIZE	26
TABLE 7: WINDOWS DISTRIBUTION	27
TABLE 8 NON-ADAPTIVE MODEL: THRESHOLD VALUES FOR COMFORT CATEGORIES. EN 15251	33
TABLE 9 ADAPTIVE MODEL: THRESHOLD VALUES FOR THE COMFORT CATEGORIES. EN 15251	34
TABLE 10 SUMMARY OF CASE STUDIES CHARACTERISTICS.....	41
TABLE 11 TOTAL ENERGY DEMAND OF ALL CASE STUDIES WITH AND WITHOUT HEAT RECOVERY VENTILATION.....	42
TABLE 12 THERMAL <i>PERFORMANCE</i> DURING THE <i>NIGHT VENTILATION PERIOD</i> ACCORDING TO EN 15251 NON-ADAPTIVE MODEL.....	47
TABLE 13 NUMBER OF HOURS IN WHICH THE OPERATIVE TEMPERATURE IS OVER THE DIFFERENT THRESHOLD DURING THE OCCUPANCY TIME.....	48
TABLE 14 AIR CHANGE PER HOUR DIVIDED BETWEEN DAYTIME AND NIGHTTIME DURING THE <i>NIGHT</i> <i>VENTILATION PERIOD</i>	51
TABLE 15 AIR CHANGE PER HOUR DIVIDED BETWEEN DAYTIME AND NIGHTTIME DURING THE <i>NIGHT</i> <i>VENTILATION PERIOD</i>	53
TABLE 16 WALL STRATIGRAPHY FROM INSIDE TO OUTSIDE	58
TABLE 17 FLOOR STRATIGRAPHY FROM TOP TO BOTTOM, WHERE TOP IS INTERNAL	58
TABLE 18 ROOF STRATIGRAPHY FROM TOP TO BOTTOM WHERE THE TOP IS EXTERNAL	58
TABLE 19 TOTAL ENERGY DEMAND OF ALL THE CASE STUDIES WITH AND WITHOUT HEAT RECOVERY VENTILATION.....	62
TABLE 20 THERMAL PERFORMANCE DURING THE NIGHT VENTILATION PERIOD ACCORDING TO EN 15251 NON-ADAPTIVE MODEL	66
TABLE 21 NUMBER OF HOURS IN WHICH THE OPERATIVE TEMPERATURE IS OVER THE DIFFERENT THRESHOLD DURING THE OCCUPANCY TIME.....	68
TABLE 22 AIR CHANGE PER HOUR DIVIDED BETWEEN DAYTIME AND NIGHTTIME DURING THE NIGHT VENTILATION PERIOD.....	69
TABLE 23 AIR CHANGE PER HOUR DIVIDED BETWEEN DAYTIME AND NIGHTTIME DURING THE <i>NIGHT</i> <i>VENTILATION PERIOD</i>	70
TABLE 24 BUILDING MODELS TRANSMITTANCE VALUES	71
TABLE 25 COMPARISON IN TERM OF TOTAL ENERGY DEMAND.....	71
TABLE 26 AVERAGE FLOW AND OPENING WIDTH	79
TABLE 27 AIR CHANGE RATES MAXIMUM, MINIMUM AND AVERAGE FOR THE TWO SOLUTIONS.....	85
TABLE 28 TOTAL ENERGY DEMAND FOR TWO DIFFERENT SOLAR SHADING THRESHOLDS	92
TABLE 29 HOURLY VELOCITIES COMPARISON.	98
TABLE 30 THERMAL INDOOR ENVIRONMENT CHARACTERISTICS FOR BOTH MODELS	98
TABLE 31 AIRING DAYTIME VENTILATION EFFECT ON THE ENERGY DEMAND.....	99
TABLE 32 HEATING ENERGY DEMAND.....	121
TABLE 33 VENTILATION ENERGY DEMAND.....	122
TABLE 34 COOLING ENERGY DEMAND.....	122
TABLE 35 NIGHTTIME ACH: MAXIMUM, MINIMUM AND AVERAGE	127

TABLE 36 WINDOWS OPENING RANGES DURING NIGHT FOR NNV MODEL	134
TABLE 37 MNV MODEL'S MONTHLY VALUES OF DAYLIGHT, COOLING AND VENTILATION DEMAND AND ARTIFICIAL LIGHTING.	136
TABLE 38 NNV MODEL'S MONTHLY VALUES OF DAYLIGHT, COOLING AND VENTILATION DEMAND AND ARTIFICIAL LIGHTING.	136
TABLE 39 NNV MODEL: PERCENTAGE OF OPENING WINDOWS RANGE AT 7 A.M.....	138
TABLE 40 NNV MODEL: PERCENTAGE OF OPENING WINDOWS RANGE AT 5 P.M.	138
TABLE 41 MNV MODEL: PERCENTAGE OF OPENING WINDOWS RANGE AT 7 A.M.....	138
TABLE 42 MNV MODEL: PERCENTAGE OF OPENING WINDOWS RANGE AT 5 P.M.	138

1. INTRODUCTION

Increase of outdoors temperature, due to climate changes, results in warmer summers even in cold climate regions. Moreover the use of wider glazing surfaces leads to high amount of incoming solar radiation. As a consequence, the moving toward low energy buildings with the improved air-tightness is raising the issue of overheating even in the middle seasons. The use of mechanical ventilation in low energy buildings has increased for guarantee the indoor air quality for the occupants, and with the new rising issue of overheating it may continue to increase for compensate the higher indoor temperatures at the expenses of higher energy need. Through the building simulation software Velux EIC Visualizer (based on IDA ICE), the effect of passive cooling strategies, such as solar shading and natural night-time ventilation, for different boundary conditions were evaluated.

A 1-1/2 story single-family house (Figure 17), located in Copenhagen's climate, was chosen for the calculation model. Through a computer simulation program, the model was used to evaluate the yearly energy demand for the chosen low energy residential building, and in particular to identify the time of the year when cooling is needed.

The work here performed can be divided in two steps. First, the effect of passive cooling strategies (e.g. solar shading and night cooling ventilation) on reducing overheating and cooling demand in two different air-tightness low energy residential buildings was considered. The implementation of heat recovery (HRV) in the mechanical ventilation system and behavioural action of the occupants on opening windows during daytime were also considered and implemented for the calculation of the cooling energy demand.

On a second moment, considering night ventilation drawbacks, a comparison in term of energy demand and indoor thermal environment with a mechanical night-time variable air volume of the ventilation system has been conducted. The starting point for this second set of simulations was the building model that best performed in the first analysis.

At the end the effect of a typical Scandinavian behaviour has considered by lowering the set-point for cooling demand to 23°C instead of 26°C.

With regards of guarantee indoor air quality and thermal comfort, the main results show that a crossed use of solar shading and night cooling ventilation leads to a cooling demand reduction that varies between 98%-100% depending on the building's air-tightness. When for security and/or other reasons the night opening of the windows is not be possible, the alternative use of active cooling by night-air through the mechanical ventilation system (MNV) could be considered. With the increased air

change rate to 1, during the night, MNV method was sufficient to compensate the cooling energy need when 26 °C of indoor air temperature set point, only increasing by 3% the total energy demand. However, different building's behaviour resulted from the two used night cooling ventilation methods. Higher (up to 2 °C) and more constant indoor air temperature performance, just below 26 °C, were obtained with the MNV simulation of night cooling that had the solar shading ON during all summer season.

When the minimum need of daylight was satisfied and the desired 23 °C of indoor temperature conditions were evaluated, higher total energy demands of 32% or 25% depending on the used strategies of night ventilation (MNV or NNV, respectively) were recorded.

Finally, results of different possibilities to reduce the increasing issue of overheating in cold climatic region, like Copenhagen, for low-energy houses were evaluated and they can be considered for further studies and evaluations of reduction of cooling energy demand with regards of indoor air quality and thermal comfort.

2. NEARLY ZERO ENERGY BUILDING (nZEB)

Climate changes have progressively produced an increased external temperature. Warmer summers even in usually cold climate are nowadays a tangible fact. Concern about this had resulted in an increased interest for passive cooling strategies to overcome low energy buildings' overheating issue.

In this first chapter of literature review, a collection of data and concepts from earlier studies are reported.

2.1 Engineering challenge

Nowadays buildings account for around 40% of total energy consumption in Europe; they also bring about 36% of CO₂ emissions. Being in expansion, this sector is leaded to increase its energy consumption [1]. For this reason a reduction of energy consumption seems to be necessary. This and the use of renewable sources in the buildings sector represent important measures which are needed to reduce energy dependency and greenhouse gas emissions. In this way, in 2010, the recast Directive on the energy performance of building (EPBD) introduced the concept of “near zero energy building” as the target from 2018 for all public owned, or occupied by public authorities buildings and from 2020 for all new buildings [1]

What is exactly a “near Zero Energy Building (nZEB)”? The Directive does not clearly define what a “near Zero Energy Building” is, either for new buildings or refurbishment of existing buildings. It gives, with Article 2(1a), just a qualitative definition:

A “nearly Zero Energy Building” is a building that has a very high energy performance. The nearly zero or very low amount of energy required should be covered to a very significant extent by energy from renewable sources produced on-site or nearby.

The EPBD does not prescribe a uniform approach for implementing nearly Zero Energy Buildings and neither describes a calculation methodology for the energy balance. This choice arises from the awareness that there is a variety in the culture of buildings and climate throughout the European Union. As stated in Bogdan (2011 [2]) this flexibility is given so that every Member States is able to draw up their own specifically designed national plans for increasing the number of new nZEB. The national plan should reflect the local characteristics of every Member State and at the same time it should try to translate the concept of nZEB in such practical measures to spread the number of this kind of buildings.

If it is true that local conditions play an essential role it is also true whether to have certain uniformity, a common methodology is needed. This necessity results from the very qualitative nature of nZEB definition that can bring to innumerable interpretations.

Kurnitski et al. (2011 [5]) wrote a manuscript where are analyzed both definition and energy boundaries conditions that will help experts of EU Member State in defining

the nearly zero energy building in a uniform way. It is stated that the Members should have a National roadmap toward nearly zero energy building. Among other things, the national plans should include the following features:

- A numerical indicator of the primary energy use expressed in kWh/m² per year. Every Member State has to use its own primary energy factor in the calculation of the primary energy use;
- Intermediate target for improving the energy performance of new buildings by 2015;
- Information on policies, financial and other measures adopted for the promotion of nZEB.

In order to define the primary energy use through a numerical indicator it would be necessary to show clearly which energy flows are included and which one are not. The numerical indicator expresses the energy performance of a building. According to EPBD recast, *energy performance* is defined as (article2 [1]):

“Energy performance of a building means the calculated or measured amount of energy needed to meet the energy demand associated with a typical use of the building, which includes, inter alia, energy used for heating, cooling, ventilation, hot water and lighting.”

Based on the Directive’s definition, a national cost optimal energy use of >0 kWh/m² per year is expected.

According the standard EN 15603:2008 [6], the primary energy, from the delivered and exported energy for each energy carrier (see Figure 1), can be calculated by equation 1:

$$E = \sum(E_{del,i} f_{del,i}) - \sum(E_{exp,i} f_{exp,i}) \quad (1)$$

where:

$E_{del,i}$ is the delivered energy for energy carrier i ;

$f_{del,i}$ is the primary energy factor for the delivered energy carrier i;

$E_{exp,i}$ is the exported energy for energy carrier i;

$f_{exp,i}$ is the primary energy factor for the exported energy carrier i.

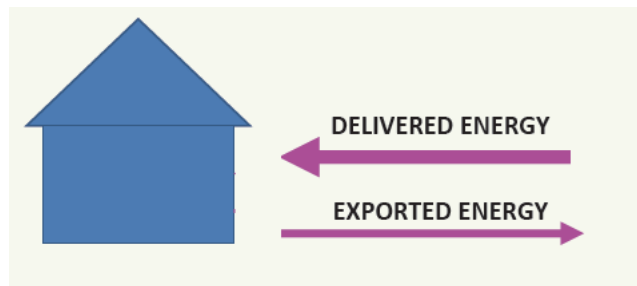

Figure 1 Scheme of Energy flux

In EPBD, a technical support on accounting electricity for households and outlets into the energy balance is missing. According Bogdan et al. (2011 [2]), it may be im-

portant to take into account all the energy uses of a building in order to achieve a sustainable nZEB definition.

Nowadays, in all low-energy buildings the amount of household electricity is comparable, in order of magnitude, with the heating/cooling and hot domestic water needs. Therefore it seems to be almost necessary considering this energy flux in the energy balance.

Summary of the definitions of low energy building standards is given in the Table 1; whereas in Table 2 is shown a summary of the Member State towards “Nearly Zero Energy Buildings”.

Although the concept and solutions for nZEB can change all over Europe, it's possible to point out some common requisites. For being a low energy building, they should have:

- High insulation level
- Very efficient windows (e.g Class A or B according to British Fenestration Rating Council ([3]) or $U_w < 0.80 \text{ W/m}^2 \text{ K}$ for cold climate according to PassiveHouse certification ([4]))
- High level of air-tightness
- Natural/mechanical ventilation with very efficient heat recovery to reduce heating/cooling needs.

In order to perform high energy performance level, nZEB also typically exploit

- Passive solar building design techniques that collect solar heat in winter and reject solar heat in summer;
- Active solar technologies like solar collectors for domestic hot water and space heating or PV-panels for generating electricity

Table 1. Definition of low energy buildings in Europe [7]

Country	Official definition
Austria	<ul style="list-style-type: none"> · Low energy building = annual heating energy consumption below 60-40 kWh/m² gross area 30 % above standard performance) · Passive building = Feist passive house standard 15 kWh/m² per useful area (Styria) and per heated area (Tyrol)
Belgium	<ul style="list-style-type: none"> · Low Energy Class 1 for houses: 40 % lower than standard levels, 30 % lower for office and school buildings · Very low Energy class: 60 % reduction for houses, 45 % for schools and office buildings
Czech Republic	<ul style="list-style-type: none"> · Low energy class: 51 – 97 kWh/m² p.a. · Very low energy class: below 51 kWh/m² p.a., also passive house standard of 15 kWh/m² is used
Denmark	<ul style="list-style-type: none"> · Low Energy Class 1 = calculated energy performance is 50% lower than the minimum requirement for new buildings · Low Energy Class 2 = calculated energy performance is 25% lower than the minimum requirement for new buildings (i.e. for residential buildings = 70 + 2200/A kWh/m² per year where A is the heated gross floor area, and for other buildings = 95+2200/A kWh/m² per year (includes electricity for building integrated lighting)
Finland	Low energy standard: 40 % better than standard buildings
France	<ul style="list-style-type: none"> · New dwellings: the average annual requirement for heating, cooling, ventilation, hot water and lighting must be lower than 50 kWh/m² (in primary energy). This ranges from 40 kWh/m² to 65 kWh/m² depending on the climatic area and altitude. · Other buildings: the average annual requirement for heating, cooling, ventilation, hot water and lighting must be 50% lower than current Building Regulation requirements for new buildings · For renovation: 80 kWh/m² as of 2009
Germany	<ul style="list-style-type: none"> · Residential Low Energy Building requirements = kfW60 (60kWh/(m²•a) or KfW40 (40 kWh/(m²•a)) maximum energy consumption · Passive House = KfW-40 buildings with an annual heat demand lower than 15 kWh/m² and total consumption lower than 120 kWh/m²
England & Wales	<p>Graduated minimum requirements over time:</p> <ul style="list-style-type: none"> · 2010 level 3 (25% better than current regulations), · 2013 level 4 (44% better than current regulations and almost similar to PassivHaus) · 2016 level 5 (zero carbon for heating and lighting), · 2016 level 6 (zero carbon for all uses and appliances)
Italy	NGO:CasaClima Gold 10 kWh/(m ² •a)

Table 2: Summary of initiatives towards “Nearly Zero Buildings” [2]

	Existing requirements for housing	2012-13	2014-15	2016	2020
Austria	2010: 66.5 kWh/m ² /year (final energy)		Proposed strategy 2015: passive house standard for new buildings		
Belgium	2010: 136-170 kWh/m ² /year (primary energy) 2011: 119-136 kWh/m ² /year (primary energy) Variation based on different regional demands				
Denmark	2010: 52.5-60 kWh/m ² /year (primary energy)		2015: 50% reduction compared with 2008		75% reduction compared to 2008
Finland	Regulated through U-values 2011: 65 kWh/m ² /year (final energy)	2012: 20% reduction compared to 2010	2015: Demand passive house for public buildings		
France	Until 2012: Dependent on region and heating source Fossil fuel: 80-130 kWh/m ² /year (primary energy) Electricity: 130-350 kWh/m ² /year (primary energy)	2012: all new buildings are low energy buildings- Effinergie standard; 50 kWh/m ² /year (primary energy)- rules made public Oct. 2010			New buildings are energy positive: E+
Germany	2009: 70 kWh/m ² /year (primary energy)	30% reduction compared to 2009			
England & Wales	Regulated through CO2 DEMANDS 2010: 100 kWh/m ² /year (primary energy)	2013: 44% Reduction compared to 2006		All buildings zero carbon proposal: 10 kg-14 kg CO ₂ /m ² /year dependent on type of dwelling or Apartments: 39 kWh/m ² year Row house_ 46 kWh/m ² /year Single family houses: 46 kWh/m ² year	

2.2 Passive House

One of the most popular concepts of nZEB is “*Passive House*” (*Passivhaus* in German). It is not an energy standard but an integrated idea assuring the highest level of comfort requiring little energy for space heating or cooling. Passive House is defined as [8]:

“a building, for which thermal comfort (ISO 7730 [9]) can be achieved solely by post-heating or post-cooling of the fresh air mass, which is required to achieve sufficient indoor air quality conditions without the need for additional recirculation of air”

The *Passivhaus* guideline for central Europe demands that the building satisfy the following requirements [9]:

- Buildings must be designed to have an annual energy demand that does not exceed 15 kWh/m^2 for heating or cooling;
- The heating and cooling load is confined as a maximum peak of 10 kWh/m^2 ;
- Total primary energy consumption (heating, hot water and electricity) must not be more than 120 kWh/m^2 per year;
- Air tightness must provide an air change rates limited to 0.6/h.

Passive House is more than just a low energy building; it can be seen as an *ultra-low energy building*. Four words can fully describe the essence of Passive houses: **energy-efficient, comfortable, affordable** and **ecological** at the same time.

As stated in the Figure 2, Passive Houses set aside 75% energy savings compared with the average new buildings construction.

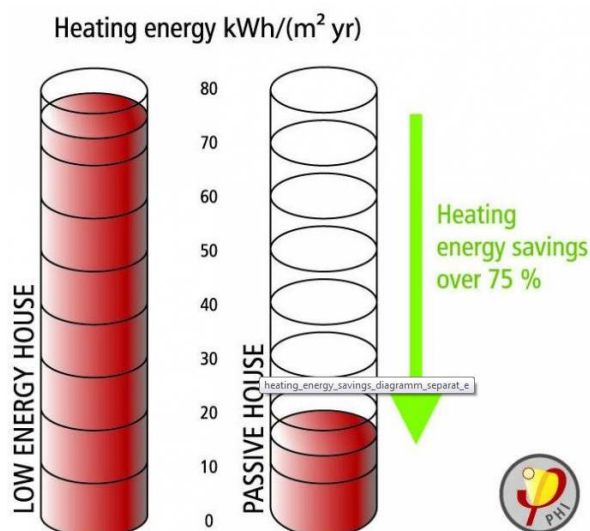

Figure 2 Passive house energy saving compared with low energy house [8]

The comfortable indoor temperature is kept through passive heat inputs:

- Externally by solar radiation through the windows;
- Internally by occupants and appliances heat loads.

An important role is played by the ventilation system in terms of indoor climate heating system. New buildings are increasing airtight characteristic for reason of energy conservation; this cause the necessity of a ventilation system to supply fresh air.

While low energy house can have different systems as ventilation and heating, in passive house the ventilation system should provide also the heating need. A good solution it will be the use of a ventilation unit with heat recovery, essential for meeting the requirements of healthy indoor climate while allowing significant energy savings.

The first Passive House was built in 1991 in Darmstadt (Germany) based on the project of Wolfgang Feist. The building has the only ventilation system which is able to heat and cool without the aid of traditional plants.

As stated in [10], the number of Passive House until the end of 2010 amount at 2269 units dislocated all over Europe, and in particular in German speaking countries.

According to PASS-NET forecast [11], where is a network of expert organizations which aim is to spread the Passive House guidelines in Europe, especially in the new EU member states, in 2015 the number of Passive House will increase to 260000 units in the PASS-NET countries (with project partners from Austria, Belgium, Croatia, Czech Republic, Germany, Great Britain, Romania), resulting in 1.430.900 tCO₂ of CO₂ savings per year.

In Figure 3 is shown the trend of built Passive House in the years for the PASS-NET countries with Germany and Austria as top countries with major number of Passive House.

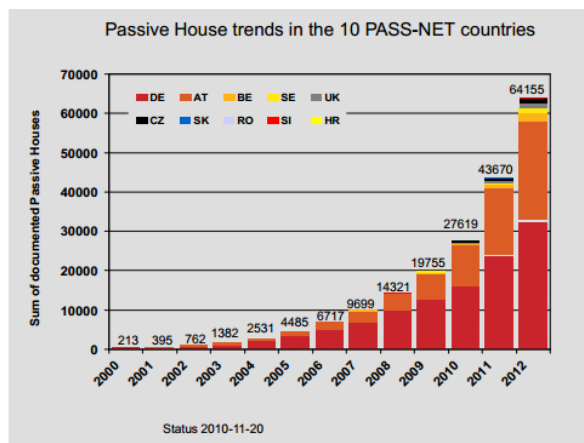

Figure 3 Evolution of Passive house between 2001 and 2012 [11]

2.3 Overheating in nZEB: an unpleasant problem

Climate changes have progressively produced an increased external temperature. Warmer summers are nowadays a tangible fact.

According to the EPBD Directive and its energy efficiency measures, transformations in building construction are necessary. The European target to 2020 is the construction of only “Nearly Zero Energy Buildings”.

As consequence the low/nearly zero energy houses with low air permeability and well insulated result in very quickly heated indoor space. The increased level of tightness’ houses causes on one side the best performance in term of non-wasted energy but, on the other, the lack of an adequate infiltration rate, could create overheating problems even if there is just a small amount of solar radiation comes through windows. This resulted discomfort could be experienced not only in the new building but also in the previous buildings that had showed overheating problems in the hottest summer months.

It is important to pay attention on the houses’ energy efficiency and, at the same time, a good indoor climate must be guaranteed inside the buildings.

According to Orme et al([12]), the most important factors that influenced overheating in well-insulated buildings are *solar radiation* and *the ventilation rate*. The importance of solar radiation is verified in the studies of Larsen et al (2012[13]) which show how the necessity of large windows areas in the southern room to increase the solar gain, could bring to critical thermal condition. Measuring the indoor temperature of a south-facing room in different conditions, they have found that its value is always above the comfort temperature as dictated in ISO 7730 [9].

Internal gains like persons and equipment could also bring to overheating problems as proved by Ulla Janson in her doctoral thesis (2010 [14]).She found that houses which experienced overheating problems were comparable to houses with considerable electrical consumption.

The only way to solve overheating problems, paying attention to energy consumption, is passive cooling. Passive cooling is a reduction of a space overheating through solutions and techniques that use climatic resource instead of electrical energy; it is based on the interaction of the building and its surroundings. The concept is not new in buildings’ cooling techniques if we think that before refrigeration technology people kept cool using natural methods. For examples breezes flowing through windows, water evaporative from springs and fountains as well as large amounts of stone and earths absorbing daytime heat. These ideas were developed over thousands of years as integral parts of building design. Today they are called “passive cooling” and this implies that energy-consuming mechanical components like pump or fans are used less and less.

The most know strategies of passive cooling are:

- *Thermal control* which consists in reduction of exceed heat before stacking;

- *Natural cooling* which consists in wasting exceeds heat through natural thermal sink.

Nowadays, for the most part, these two methodologies are combined getting higher results in term of indoor thermal comfort.

2.3.1 Thermal control

The aim of thermal control is to slow heat transfer into the building. There are different control strategies such as:

- Solar shading control;
- Air convective control;
- Internal heat gain control.

An important role is also played by thermal mass of buildings structure. Thermal mass is a concept in building design that describes how the mass of a building provides “inertia” against temperature fluctuations during the day. Thermal mass is effective in improving building comfort both in winter as well as in summer; when it is combined with other thermal strategies, like passive solar control, it can lead to a significant reduction of energy use in active heating and cooling system. High thermal mass depends on the ability of materials in the building to absorb heat during the day. Studies [16] [17] demonstrate that a light weight structure required more energy to cool down the building if compared with a heavy-mass building. The importance of buildings thermal mass on the indoor temperature is also highlighted in Pearlmutter and Meir (1995 [18]) study. They compared the indoor temperature in two residential buildings with different thermal mass, one conventional high-mass and one with lightweight structure, and with similar size and heat loss coefficient. Under different ventilation conditions, they found that the lightweight building has the most fluctuating indoor temperature as shown in Figure 4.

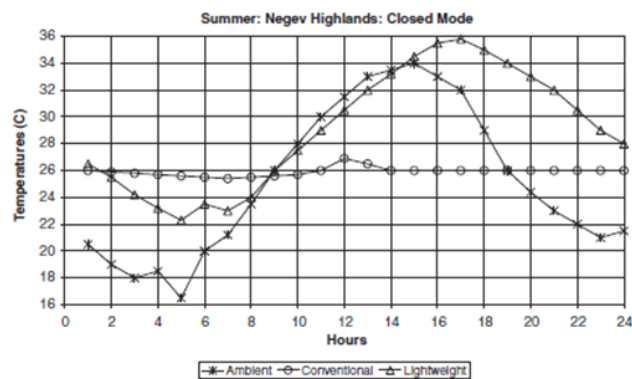

Figure 4 Measured indoor temperatures of the two buildings in summer season [18]

In this paragraph we want to pay attention on the first of the thermal control strategies mentioned that is *solar control*. The aim of solar control tactics is to slow down

the absorption of direct solar radiation by the building structure. This phenomenon can be prevented using solar shading. In its simplest form, solar shading is any device which excludes sunshine from a building like a curtain or an awning. An analysis of the problems with overheating shows that implementing the option of active use of windows airing in buildings combined with external solar shading is essential in the future. Solar shading controls the amount of heat and light admitted to a building. By doing so, solar shading devices can offer energy saving in various areas. They can reduce the need for heating or cooling by maintaining a more even temperature despite varying climatic condition. These cooling demand reductions are demonstrated in the studies of Gratia et al (2004 [19]); they analyzed the cooling demand of a narrow office building sited in Belgium (the climatic data were referred to Uccle(BE)), finding that it can be reduced of about 33% by using outside blinds of medium color instead of any shading system.

In the ISO 7730[9] operative temperature (t_o) is defined as:

“the uniform temperature of a radiant black body enclosure in which occupant would exchange the same amount of heat as in the actual non-uniform environment”.

In practice, the operative temperature is determined as the average of the mean radiant temperature (t_{mr}) and mean ambient air temperature (t_a), weighted by their respective heat transfer coefficients (h_r , h_c), as reported in equation 2 :

$$t_o = \frac{t_{mr}h_r \cdot t_a h_c}{h_r + h_c} \quad (2)$$

The mean radiant temperature depends on the radiant exchange between surfaces, opaque as well glazed; consequently it depends on solar radiation that crosses the external surfaces. In this way reducing the incoming solar radiation the operative temperature can be controlled for creating a good indoor thermal condition, particularly important in office buildings where several studies ([20], [21], [22]) show the correlation between mean radiant temperature, indoor environmental quality and humans' productivity inside buildings. These studies highlight how too high or low temperature brings to deteriorate work performance inside office. Seppänen et al. (2006 [17]) calculated the percentage of performance change per degree increase in temperature, and statistically analyzed measured work performance with temperature. The results show that performance increase with temperature up to 21-22 °C, and decreases with temperature above 23-24 °C. In their studies the highest productivity is reached at a temperature around 22 °C (for example, at the temperature of 30 °C the performance is only 91.1 % of the maximum i.e. the reduction in performance is 8.9 %).

Nowadays large glazed surfaces have been increasingly used in buildings architecture due to their unique advantages: they can both reduce lighting energy consump-

tion by making full use of daylight and they can provide free heat load during the heating period. However their use can bring to some problems like high cooling demand in summer and thermal discomfort. Solar load are predominantly confined to areas close to the windows; in fact, there could be a significant difference between loads close to the windows and the occupant space. A high windows surface temperature increases the radiant load and will usually lead to local discomfort. Also the air distribution could be affected from high temperature creating problems with draught. For all these reasons the use of large glazed surfaces combined with external solar shading is essential in dwellings as well as in offices.

Solar shadings solutions

There is an extremely wide variety of solar shading products available which range in function and sophistication. In the following figures 5 and 6 are shown different external solar shading.



Figure 5 Different solutions for external solar shading [14]



Figure 6 Hendon Magistrate Courts, fixed solar shading timber Louvers [15]

One of the best solutions to reduce heat windows losses is adopting double glazing. They consist in two float glass panes separated by a closed county between 6-16 mm. The use of such glazed although can produce, during summer period, overheating problems.

Solar control glasses are a wide range of double glazing: their effectiveness belongs from the great mixture between a good visible transmittance with a low g-value (SHGC gives the % of the incident solar energy that eventually reaches the interior as heat).

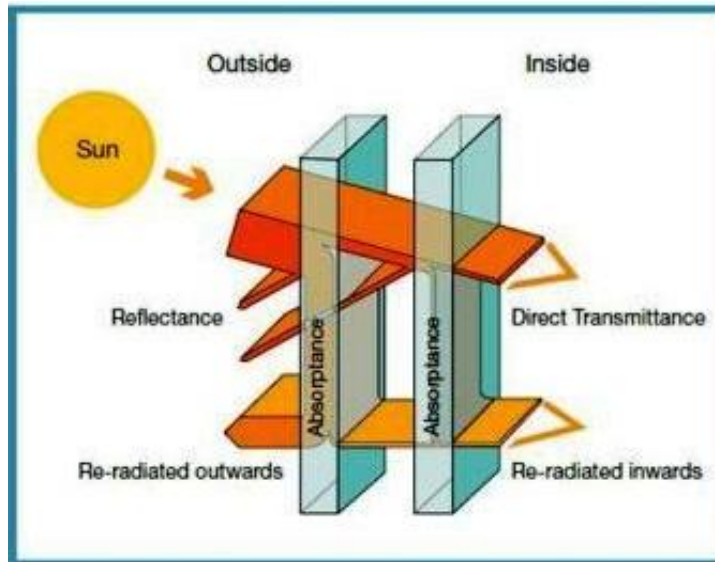

Figure 7 Structure of a double glazing

In principles, the use of solar shading results in three functional benefits:

- Reduction in cooling need in summer
- Reduction in heating need in winter
- Improvement in visual and thermal comfort.

These three functional benefits can be collected when the shading system is automatically controlled. In this way, even if occupants are absent, it will react to the sun and the wind by itself without requiring any attention. If there is a kind of maintenance in this direction the system will greatly improve indoor thermal comfort and occupant satisfaction.

2.3.2 Natural cooling

Natural cooling consists in wasting exceeds heat through natural thermal sink. The main processes of heat dissipation that have been well studied and developed are:

- Ground cooling based on the coupling of buildings with the ground;
- Ventilative cooling based on the use of ambient air;
- Evaporative cooling using the water as heat sink.

The aim of this paragraph is to analyze the ventilation strategies that can be useful to cool down the building. The principal purpose of ventilation is to satisfy indoor air quality requirement (“hygienic ventilation”) but it could be also used as a means for heating and cooling the space which is being ventilated. It is conveniently to keep in mind that the provision of space cooling is in response to the necessity to satisfy occupant’s thermal comfort as recommended in the Standards (ISO 7730-2005, EN 15251, and ASHRAE 55-2010 [23]). In particular, the six parameters representative of the occupant’s thermal comfort must be controlled; they are:

- Four physical: air temperature, radiant temperature, air humidity and air velocity;

- Two behavioral: metabolic rate (related to the degree of activity) and insulation clothing level.

Thermal comfort is a complex function of many different variables; if a parameter change its effect could be balanced varying another of the six parameters and remaining in the same range of internal comfort. An example is given in figure 8. It is shown that higher air speed in a building extends the upper limit of the comfort zone providing a direct physiological cooling effect ([24]); indeed as air speed increase the rate of body heat loss increases and so the same level of comfort is achievable at a higher air temperature.

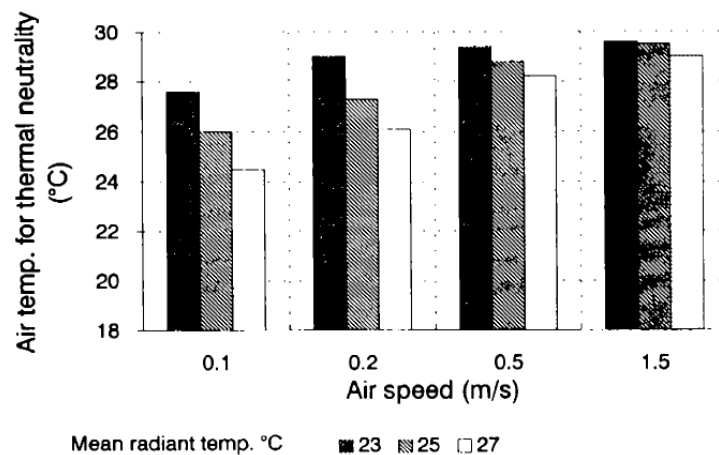

Figure 8 Effect of air speed and mean radiant temperature of the enclosure on the thermal comfort [24]

Several studies ([25], [26], [27]) have demonstrated the positive effect of increased air velocity on thermal comfort especially in hot region. The cooling potential of ventilation is also a function of the inside-outside temperature difference and the air flow rate. Being outside temperature uncontrollable by the designer, the only way to maximize the cooling potential is increasing flow rate or allowing a higher room air temperature. It could be obtained reducing the mean radiant temperature (by using night cooling coupled with high thermal capacity) and increased air speed.

Natural ventilation regulates a building's indoor climate by exploiting the natural forces created by temperature differences between the interior and exterior environment, thermal displacement within the building and winds around the building. The air is kept fresh by controlling air replacement; the air flows to or from a building through specific opening like windows in the building's façade and/or roof. Ventilation process is caused by naturally produced pressure due to wind and stack effect. A detailed analysis of the physic phenomenon of building's ventilation is given by H. Awbi's book titled "Ventilation of building" [28].

The most widely used natural ventilation strategies are:

- Single-Sided Ventilation (see Figure 9): the simplest form for providing air change flow. The driving force is the wind pressure, particularly the flow due to buoyancy moves through a large opening thanks to the pressure difference caused by temperature difference across the openings.

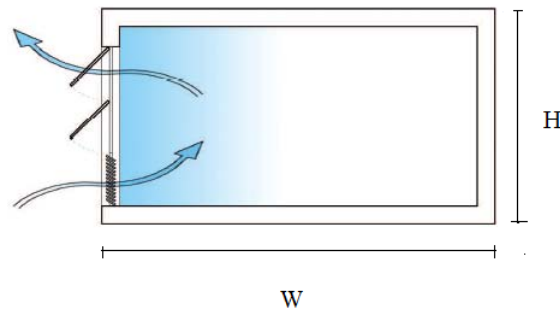

Figure 9 Example of Single-side ventilation. It is effective only when $W=2,5 H$ [29]

- Two-Side or Cross Ventilation (Figure 10): occurs when air enters in the room (or building) from openings on one side and leaves through openings on the other side. The air flow is mainly due to wind pressure; buoyancy pressure becomes important only if there is a significant difference in height between the inflow and outflow openings.

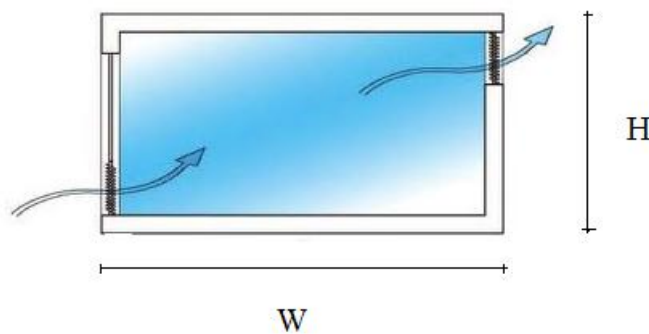

Figure 10 Example of Cross Ventilation. It is effective only when $W=5 H$ [29]

- Stack ventilation (Figure 11): used for buildings which require ventilation rates greater than those achievable using the previous two mentioned methods. In this case, buoyancy is the main driving force; therefore, the height of the stack becomes significant. The difference between the internal and the external pressure defines the stack pressure that could be calculated by equation 3

$$p_s = -\rho_0 g h \left(1 - \frac{T_o}{T_i}\right) \quad (3)$$

where:

ρ_0 is the air density;

g is the gravitational acceleration;

h is the vertical distance between two vertical openings;

T_o is the outdoor air temperature;
 T_i is the internal air temperature.

The wind pressure could support the stack pressure; it depends on the position of the air inlet and outlet in the building. It is necessary a carefully design because wind can assist stack effect and reduce its influence or indeed reverse the effect. Especially when stack are incorporated in the building, meticulous consideration are needed to avoid these adverse effects occurring. The following systems are part of this category: large enclosures, wind catchers, solar-induced ventilation and solar chimney. A carefully description of these systems is given in H. Awbi's book "Ventilation of Building"[28].

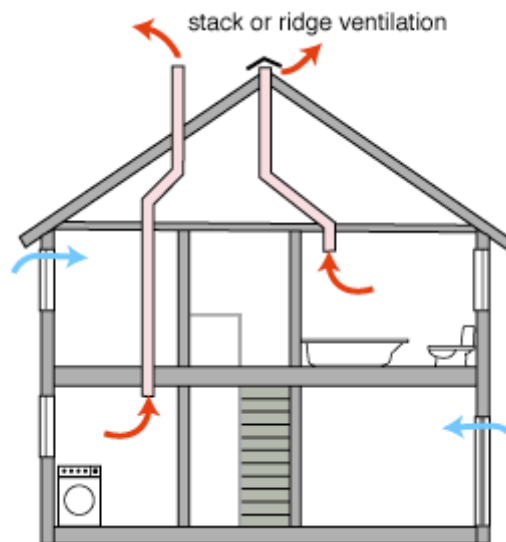

Figure 11 Example of Stack Ventilation [30]

Doubtless natural ventilation's driving force is the weather; in cold or windy weather the ventilation rate will be sufficient to ensure thermal comfort. Natural ventilation's cooling capacity depends on the temperature difference between inside and outside air at the times when most cooling is likely to be required. It is one of the reasons why the study should focus on the cooling potential of natural ventilation at nighttime. During the night, indeed, the temperature difference between external and internal air is greater and besides the thermal mass of the building can be used to store the "cold" that can be released to the environment at daytime. Studies about the effectiveness of night cooling techniques for residential buildings in the hot-humid climate of Malaysia (2009 [31]) have shown how the peak indoor air temperature can lowered of 2.5 °C, and the nocturnal air temperature can be reduced by 2 °C on average if compared with a daytime ventilation. Similar results were found for three real buildings located in Athens from Geros et al (1999 [32]) whom achieved good performance in the decreasing of the next day high peak of indoor air temperatures. Under free-floating condition, 3 °C less for buildings with high thermal mass while only 0.2 °C for low thermal mass buildings. They also found a reduction of the over-

heating hours, which ranged between 39% and 96 % for air flow rate with 10 ACH and 30 ACH respectively, as it is shown in Figure 12.

The night cooling ventilation is the simplest and cheapest option to cool the buildings, however it is the most difficult to be controlled since the driving force, wind and pressure, change constantly with the weather and with the site (2000 [33]).

It requires a careful design of building's type, size, shape and sides opening locations (e.g. windows).

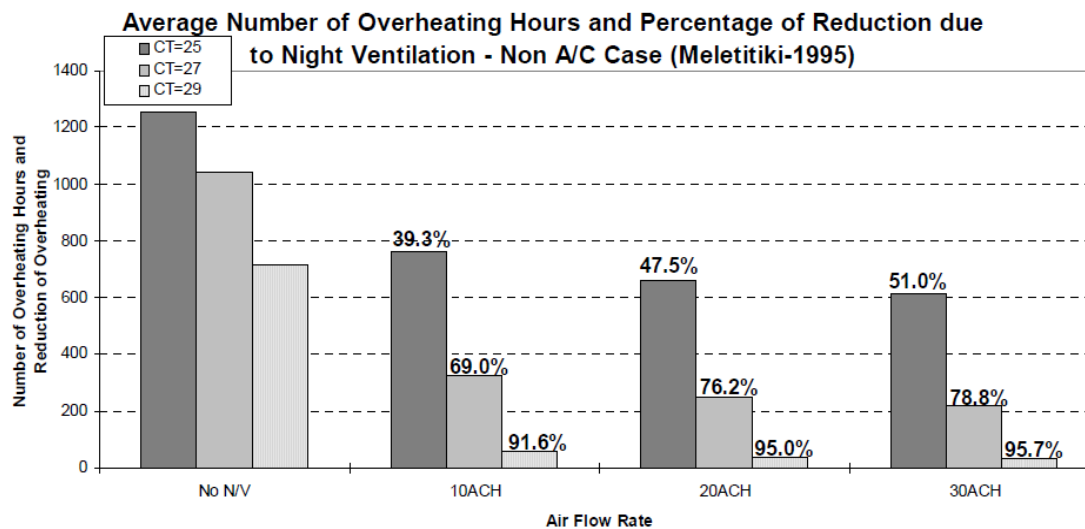

Figure 12 Reduction of overheating hours due to the use of natural ventilation [32]

Gratia et al (2004 [19]) have tried to give some information on the relationship between windows openings and air change rates in a certain type of building, to give suggestions for designing a building envelope. They found, referring to a narrow office building of 5 floors with 15 office modules per floor, that:

- Single-sided day ventilation is much more effective than cross ventilation and it can reduce cooling needs by about 30%;
- Night cross ventilation and single-sided ventilation are almost effective and both reduce the cooling needs by about 40%;
- To optimize single-sided ventilation, two openings positioned on different heights are much more efficient than one single openings;
- In absence of wind, to originate a cross ventilation it is better that windows opening on both sides have different heights.

The use of passive cooling techniques as natural ventilation is necessary not only to avoid overheating's problems but also for reducing the peak electricity load mainly because of the very rapid penetration of the air conditioning that we have seen in the last 30 years. The use of air conditioning has an important effect on the consumption of a building; studies [34], [35] have in fact proved that in Europe, because of the use of air conditioning, the consumption of commercial buildings have increase to about 40 kWh/m² year. Then night ventilation could be one of the best passive cooling

techniques able to improve thermal comfort by reducing the operational costs for air conditioning.

Night ventilation is best way to cool down a building in areas with high diurnal temperature range and where nighttime temperature is not so cold to create discomfort. Although a very powerful techniques, night ventilation presents considerable restrictions as condensation and moisture problems, privacy and/or security problems (because of the windows opening during night), pollution, and acoustic problems especially in city center buildings. However, the more important limitation of night ventilation techniques is associated with the specific climatic conditions. As stated before the weather condition and the difference temperature between night- day and indoor-outdoor are the parameters that more influenced the performance of night ventilation.

An interesting study about the climatic potential for passive cooling of building by nighttime is reported by Artmann et al (2007 [36]). They evaluated passive cooling's potential just analyzing climatic data without considering any buildings specific parameters; the method is based on a variable building temperature, variable within a temperature range of thermal comfort as specified in international standards. To define the potential for ventilative cooling during a period of N nights they introduce the "climatic cooling potential" factor (CCP) as a function of building and external air temperature. As shown in Figure 13, the CCP is higher in Northern Europe countries, having a sufficient cooling potential for avoid overheating. The performance is less significant for Central and Southern regions of Europe where night-time ventilation might not be sufficient throughout the year.

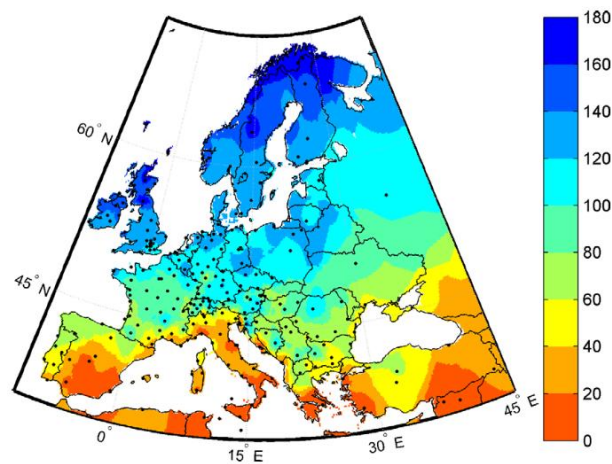

Figure 13 Map of mean climatic cooling potential (Kh/night) in July [33]

As proved by the available studies, night natural ventilation can support the energy savings policy with respect of indoor thermal comfort in moderate and cool climate areas but can barely substitute the mechanical cooling ventilation system in warmer climate.

When passive system cannot provide a sufficient cooling effect hybrid ventilation system should be considered. Hybrid ventilation is a system in which natural is combined with mechanical ventilation system for providing indoor thermal comfort. This

is a smart system that, employing control schemes, are able to switch automatically from natural to mechanical maintaining a satisfactory indoor environment and minimizing energy consumption. The decrease in the total energy demand using hybrid ventilation is also demonstrated, among different studies, e.g. Foldbjerg et al. (2011, [37]). The energy performance of two hybrid residential ventilation systems, one manually and the other automatically controlled, pointing out that the reduction made with the automatic control is bigger than by manual control (respectively in the range of 2.7-4.7 kWh/m² for automatic and 1.3-1.7 kWh/m² for manual control).

T. Pellegrini in his master thesis (2012[38]) has analyzed and compared the performance, in term of thermal comfort, indoor air quality and energy consumption, of ten ventilations and cooling strategies in four different climatic zone across Europe. The ventilation strategies consist in natural, mechanical and hybrid methodologies with increased air velocity during the day and night cooling. The study, made on a residential 1 1/2 storey single-family house, has confirmed the trend that passive cooling approach is capable to ensure a good indoor environment in term of high IAQ (Indoor Air Quality) and prevention of both overheating and overcooling, as well as a reduction in energy consumption. The study seems to be a confirmation of Artmann et al (2007 [33]) conclusions about the climatic cooling potential of European zones. Indeed, the best performances, only with the night cooling strategy, were obtained for the cold climate of Copenhagen.

2.4 Reinventing the past

The delicate issue of energy reduction faced out in the last decades, has shaded light on new way to cool down and/or heat a building that use climatic resource instead of electrical energy. This new concept is based, as dealt with in the previous paragraphs, on the interaction of the building and its surroundings.

Nevertheless passive strategies are not a completely new concept but more importantly are a reconsideration and reuse of strategies exploited in the past before mechanical air conditioning arrival.

Just keep in mind that, before technology coming, different architectural stratagems were used to prevent building overheating and/or overcooling, depending on climatic region. For example in the warm Mediterranean climate it was very common to build underground. Those constructions, called “Hypogeum”, were exploiting the hygro-thermal exchange with the ground making the indoor temperature stable and creating a comfortable indoor environment especially during hot summer (Figure 14). Even if they were used mainly as tombs, olive-press or food storehouse, they are an example on how primitive populations were using nature and surroundings in efficient way.



Figure 14 Lagrasta's Hypogeum, Canosa di Puglia, Italy

The benefits of using thermal mass to provide “inertia” against temperature fluctuations during the day were also well known in the past, e.g. the “Leccese” dome ceiling (Figure 15) very common in south part of Apulia (Italy). The structure is a double tuff stone wall filled with little stones, while the ceiling is a lowered dome, typically called “Leccese”, usually constructed without wooden bridge house.



Figure 15 Typical dome ceiling of southern Apulia

Designed for hot climates, they were habitually equipped with very small openings that face Nord and West orientations. The cooling strategies were based on thermal mass displacing and softening the heat flux. Dissipation of the extra heat, stored by the structure during the day, was also supported by the ceiling dome that during the night allowed through re-irradiation the loss of extra heat. Ventilation cooling was also provided by opening the door/windows that faces Nord during the early morning when the outside temperature is still low, making possible a fresh air flushing into inside.

Referring to thermal comfort, dome ceiling was the most adequate solution for hot climates latitudes. Warm air, stacking just below the arching, was flushed out through dedicate openings. Moreover, wider surface than a flat ceiling helped during daytime in absorbing less solar radiation and during nighttime in removing extra heat. The efficient ejection of warm air was also allowed by curvature that, increasing outside crossing cold wind by Bernoulli-Venturi effect, made possible lowering

the temperatures surfaces. It explains why in hot Middle East climate the use of dome ceiling is so widespread even nowadays.

Architectural and design solutions can sometimes become extraordinary artwork as it is Antonio Gaudi's "Casa Batlló", built in Barcelona on XX century.

Concerned of appropriate orientation of the buildings, system regulation of solar radiation, exploitation of natural ventilation and lighting are typical in Gaudi's work. His interest to achieve the user's comfort and welfare by means of the proper use of natural energies is then notably shown in the domestic architecture.

In "Casa Batlló", with a skillful plays of openings, cracks in both outside and inside building façades, windows and/or doors wooden regulative openings(Figure 16), he created a dedicate cross ventilation by exploiting sea breezes. By regulating the amount, speed and direction of air, users' thermal comfort was possibly achieved.

His focus on daylight is notable from the central courtyard (Figure 16) covered by bright potter changing on blue tones that, indeed, has a double role: thermal regulator from one side and daylight predominant way from up to down at the lowest floor level. By going from the roof to the ground floor, color intensity decreases becoming white at the bottom. The light diffusion caused by the different gradation interplay, makes possible a uniform daylight all over the courtyard.

The "Casa Batlló" embodies all the benefits of solar energy with the help of thermal gains, thanks to direct solar radiation or by means of the exploitation of natural lighting and natural ventilation. Since the beginning of last century, it is considered a relevant example of environmental conscious design.

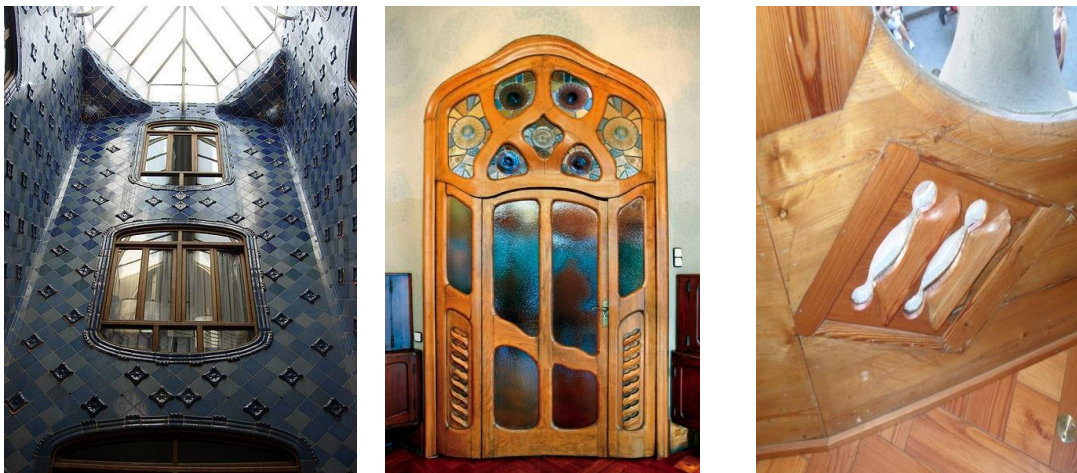

Figure 16 internal courtyard (left), door with small openings for natural ventilation (middle), cracks for air recirculation (right).

3. BUILDING MODEL AND METHODOLOGY

In this chapter the characteristics of the used building model and the methodologies adopted to analyze the results are presented. Particular attention is given to the windows features and controls because are the key point of the passive strategies utilization.

3.1 Building characteristics

The building use in this study refers to a model originally designed by J. Kragh et al. (2008[38]) for a proposal of energy rating system of windows in EU. It is a 1 1/2-story, single-family house (Figure 17) basically designed to optimize the performance of passive cooling strategies and to minimize the energy consumption in the Northern European countries. In the very simplified model particular attention is given to the windows size and distribution, aimed at the reduction of electric consumption for artificial light and also to increase the cooling potential of natural ventilation techniques. For that reason the windows face each other making possible the best use of air cross ventilation.

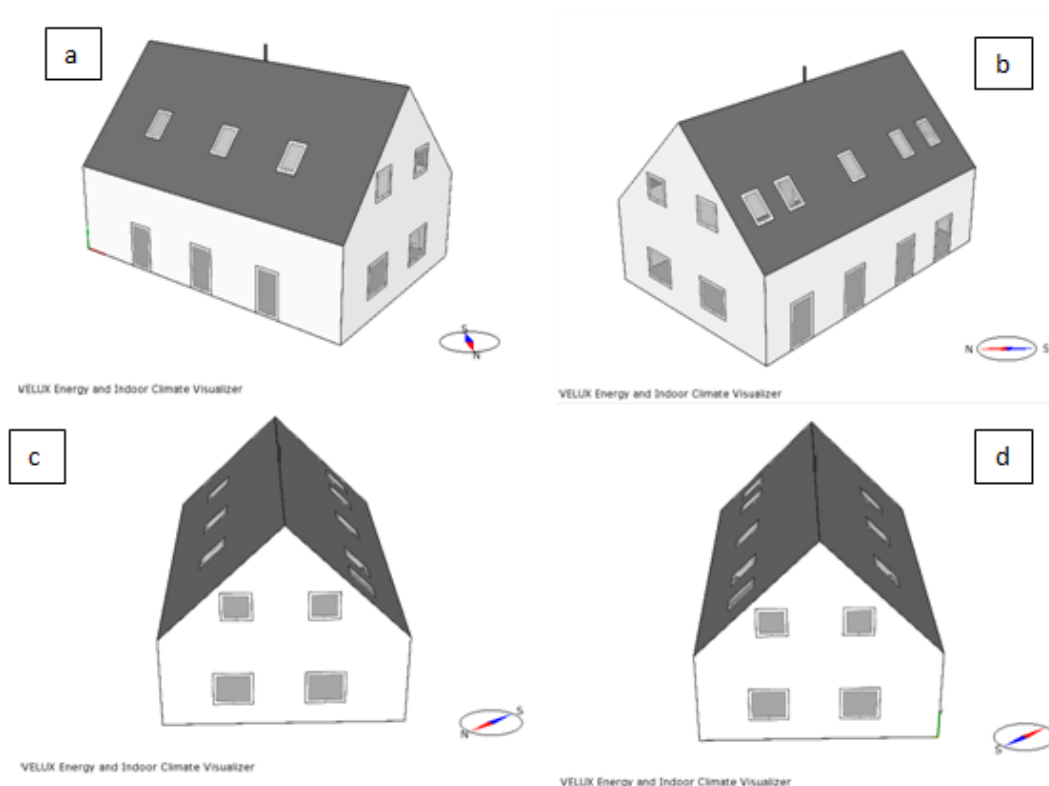

Figure 17 Visual representation of the model from Velux Energy and Indoor Climate Visualizer.

The building has an internal length of 12 m and width of 8 m, a floor area of 175 m², and a 45° sloped roof. The maximum height of the building is 7.3 m.

The same building model has been previously used as case study by T. Pellegrini et al. (2012, [38]). They investigated how to improve summer thermal condition by means of ten different ventilation and cooling strategies in different climate. In the first simulations sets for the climate region of Copenhagen, Pellegrini (et al., 2012, [38]) identified the building's orientation, the best night ventilation threshold and the thermal mass, with respect to energy consumption and thermal comfort.

The chosen values are:

- NORD-EAST orientation (see Figure 17a);
- Temperature threshold for night cooling equal to 23°C;
- 20 cm of concrete layer for the building thermal mass.

For this study, the same building thermal proprieties (transmittance U-value (U) and thickness (s)), have been kept equal to:

- External walls: $U=0.34 \text{ W/m}^2 \text{ K}$; $s=0.41 \text{ m}$;
- Floor: $U=0.32 \text{ W/ m}^2 \text{ K}$; $s=0.43 \text{ m}$;
- Roof: $U=0.23 \text{ W/ m}^2 \text{ K}$; $s=0.37 \text{ m}$.

Detailed values of building stratigraphy are collected in Tables 3, 4 and 5.

Table 3: WALL stratigraphy from inside to outside

Material	thickness [m]	heat conductivity [W/(m K)]	density [kg/m ³]	specific heat [J/(kg K)]
internal plastering	0.01	0.7	1400	850
concrete layer	0.2	1.7	2300	1000
mineral wool	0.1	0.04	30	850
outer layer	0.1	0.99	1800	850

Table 4: FLOOR stratigraphy from the room inside surface

Material	thickness [m]	heat conductivity [W/(m K)]	density [kg/m ³]	specific heat [J/(kg K)]
stone	0.01	3	2700	880
concrete layer	0.2	1.7	2300	1000
insulation	0.1	0.04	50	850
concrete ENISO13792	0.1	2.1	2400	850
acoustic board	0.02	0.06	400	840

Table 5: ROOF stratigraphy

Material	thickness [m]	heat conductivity [W/(m K)]	density [kg/m ³]	specific heat [J/(kg K)]
external layer	0.01	0.23	1500	1300
insulation	0.16	0.04	50	850
concrete layer	0.2	1.7	2300	1000

Building has been considered having 0.05 ach (air change) of infiltration corresponding to 0.023 l/s m² of external surface, at the pressure difference of 50 Pa.

The losses caused by the presence of thermal bridges are:

- Joint between an internal slab and external wall: 0.01 W/K m;
- Joint between an internal wall and an external wall : 0.01 W/K m ;
- Joint between two external walls : 0.06 W/K m;
- External windows perimeter : 0.02 W/K m;
- External door perimeter: 0.02 W/K m;
- Joint between the roof and an external wall : 0.07 W/K m;
- Joint between an external slab and an external wall : 0.08 W/K m;
- Joint between a balcony floor and an external wall: 0.1 W/K m.

It was assumed that the building is a four people family house. During the weekdays (from Monday to Friday), it was assumed that the occupants are out from 8 a.m. to 5 p.m. going to work or school; while during the weekends there is always somebody at home. According this assumption the occupancy schedule controls was created for controlling the air handling units' fans and the indoor lighting system.

The light electrical power was assumed to be 4 W/m^2 with a maximum lighting power of 525 W, which correspond to 75 % of lighting turned ON simultaneously. The lights will be turned ON only when both of the two conditions are satisfied: people are at home and the average daylight is 0 lux. Besides, when the average daylight is above 50 lux the artificial lights are turned OFF even if there are occupants. This setting has been assumed for the residential building, different from office space, where the use of the artificial light in single room is not predictable and depends from the occupant. Nevertheless, in this way a minimum value of 50 lux of lighting, natural and/or artificial, will be guaranteed.

The occupants' activity was assumed to be equal to 1.2 met (corresponding to 70 W/m^2 of human-body surface) the average clothing insulation levels was assumed to be equal to 0.75 ± 0.25 clo. The clothing insulation is automatically varying with the seasons, higher in winter and lower in summer, and with the limits of thermal comfort between the predicted mean vote (PMV) equal to -1 when occupants wear maximum clothing (in winter) and equal to +1 when with the minimum clothing (in warmer season).

In the building the consumption of hot water for each occupant is assumed to be 40 l/day while, the electrical consumption of the equipment (always ON) has been set equal to 4 W/m^2 of floor area.

3.2 Windows, doors and solar shading

Windows and doors' position and size have been chosen according on what is stated in Kragh et al[39]. The total glazed area is 30.4 m² corresponding to 17% of floor area. Five VELUX windows have been chosen having different geometric sizes as listed in Table 6 according the building orientation. In particular, only the windows located at the roof are the Velux horizontal pivoting type (see Figure 19).

All windows have the same U-value of 1.107 W/(m²K) with the exception for the pivoting windows at the roof equal to 1.1471 W/(m²K).

The window glasses are the 2 pane-type with the following proprieties:

- Solar heat gain coefficient (g): 0.6;
- Solar transmittance (τ): 0.54;
- Visible transmittance (τ_{vis}): 0.77;
- Internal emissivity: 0.837;
- External emissivity: 0.837.

The U-value of the frame has an average value of 2.5 W/m² K).

Table 6: Windows and doors size

Type	Window number	Building Orientation	Width [m]	Lenght [m]	Glazed Area [m ²]	Description
A1	1_2_3_4_5	SUD-WEST	0.78	1.178	4.6	Horizontal pivoting window
A2	6_7_8	NORD-EAST	0.78	1.178	2.8	Horizontal pivoting window
B	9_10_11_12	SUD-WEST	1.08	1.80	7.8	Vertical door
C	13_14_15	NORD-EAST	0.97	1.70	4.9	Vertical door
D1	16_17	SUD-EAST	1.31	1.21	3.2	Vertical window
D2	18_19	NORD-WEST	1.31	1.21	3.2	Vertical window
E1	20_21	SUD-EAST	1.00	1.00	2.0	Vertical window
E2	22_23	NORD-WEST	1.00	1.00	2.0	Vertical window

The glazed area distribution toward the orientation is reported in Table 7 including the percentage of glazed area for facade.

For all the windows, the used sunshade is the typical Velux awning blind (see Figure 17), located externally, having the following coefficients:

- Multiplier for U-value : 0.90;
- Multiplier for solar heat gain factor: 0.1;
- Multiplier for the solar transmittance: 0.05.

Table 7: Windows distribution

Orientation	Façade Glazed Area	
	[m ²]	[%]
SUD-EAST	5.2	17
SUD-WEST	12.4	41
NORD-EAST	7.7	25
NORD-WEST	5.2	17

Figure 18 shows windows orientation and numeration according to Table 6. The automatic solar shading system is based on a PI controller shown in Figure 19-left, that it is activated when the increasing mean air temperature reaches the selected set point of 23°C. Sunshades are used in order to maintain the indoor air temperature by modulating the solar radiation that enters the building through the windows glazed surface.

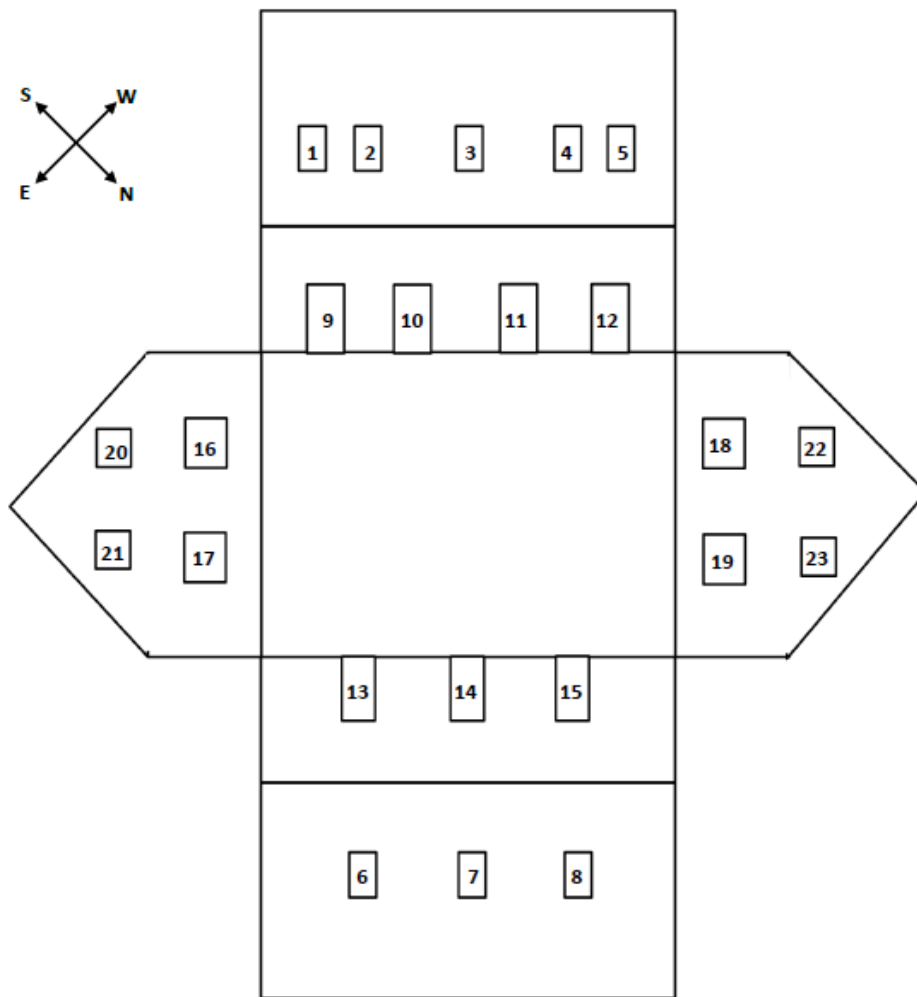

Figure 18 Orientation of numbered window in the building-plan

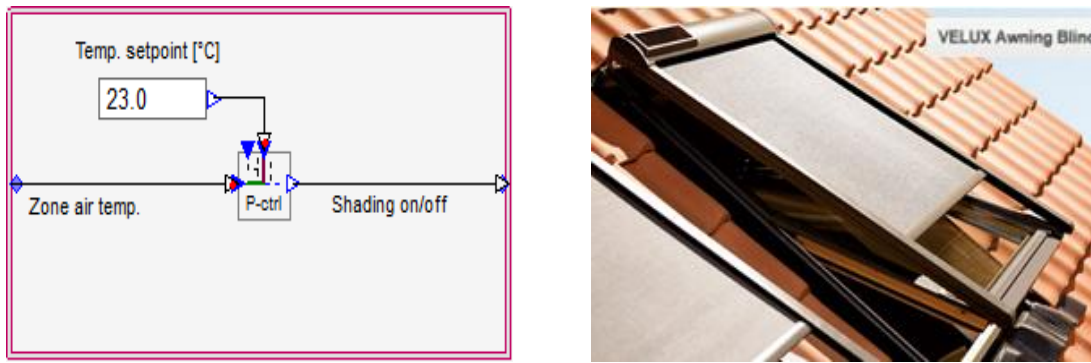

Figure 19 Control strategy for the sunshade (left) and example of Velux Awning blind (right)

VELUX's windows opening control has been used in almost all the analyzed models. The complete control, shown in Figure 20, consists of two different parts, daytime and nighttime with different working logics.

During the nighttime control there are two conditions determining the windows opening:

1. Indoor air temperature (t_a) has to be above the selected threshold of 23 °C (according the earlier chosen and discussed conditions of Pellegrini et al. [38]);
2. Indoor air temperature (t_a) higher than outdoor.

Both the nighttime control conditions are tested at 10 p.m. when it is assumed that the occupants go to sleep. If the recorded temperatures are satisfied ($t_o < 23$ °C and $t_a > t_o$) the windows will be open for the entire night, according the window opening control (Figure 18). The modulation of the windows opening is obtained through the following proportional controller:

- if $t_a > 23.5$ °C, the windows are fully opened;
- if $23.5^\circ\text{C} < t_a < 22.5$ °C, the windows opening is modulated;
- if $t_a < 22.5$ °C, the windows are fully closed.

A nighttime schedule is used to make sure that this part of the control will be used only during night.

The daytime control is used to simulate the human behavior by the automatic opening of the windows.

During the daytime control the following conditions must be simultaneously realized for the window opening:

1. $t_a > 23^\circ\text{C}$;
2. Outdoor air temperature (T_{out}) can be maximum 2°C higher than t_a . This condition prevents building overheating when the temperature outside is much higher than inside;

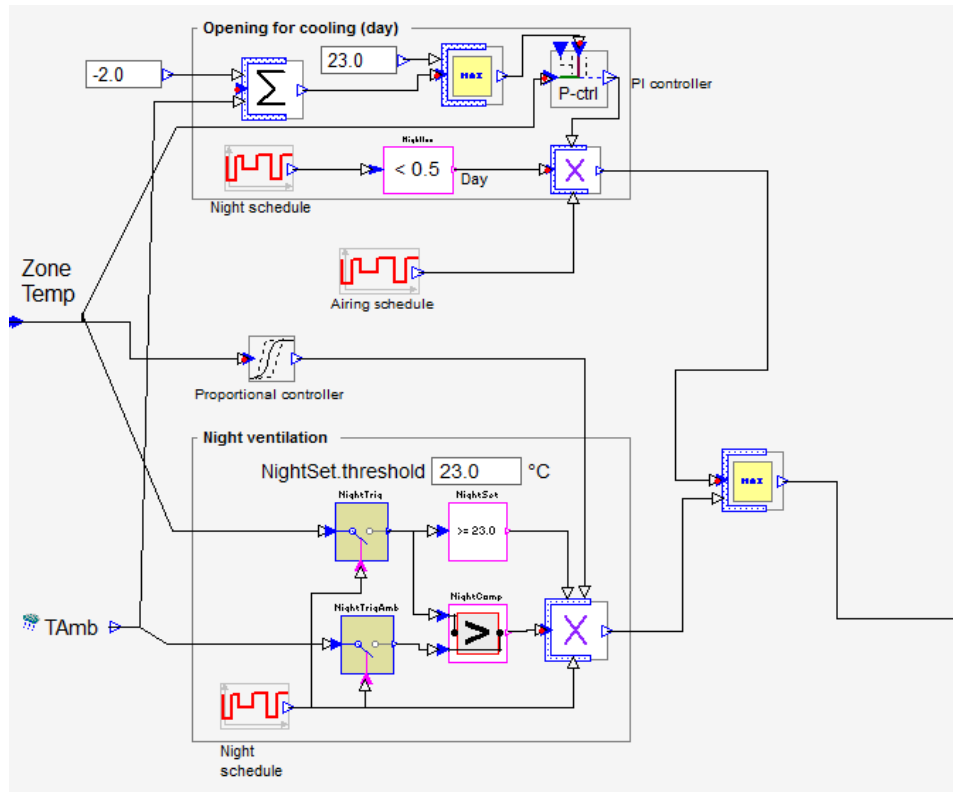

Figure 20 Control strategies for window opening (screen dump from Velux EIC)

The just described window control is one of the Velux's controls for the opening of the windows. As reported in Pellegrini et al. study [38], this kind of natural ventilation strategies during daytime turned to be too aggressive for the cold climate of Copenhagen if applied for long term period during the day. For this reason another condition for the daytime natural ventilation through the windows has been set in order to meet at the same time the occupant's thermal comfort and the necessity to prevent overcooling. It allows the opening of the windows only for a short period of 15 minutes in the early morning, at 7:00 a.m., and when the occupants is assumed to be back at home, at 5:00 p.m., for airing the dwelling. A view of the airing schedule control is shown in Figure 21.

The controller is based on a PI logic which means that the windows will start to be open when the measured indoor temperature is 1 °C higher than the threshold (23 °C).

Moreover, the opening window area is modulated to maintain the set point value; this means that the windows will not open all at once. The daytime is different from the night time (10 p.m. to 7 a.m.) window schedule control (Figure 21) having different airing schedule.

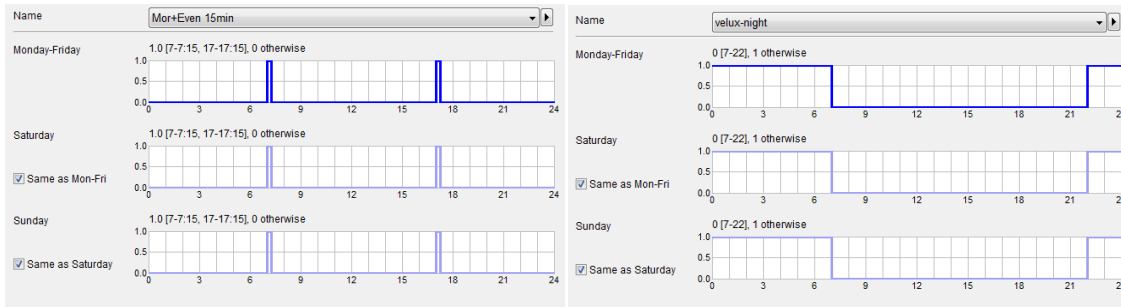

Figure 21 Airing schedule (left) and Night schedule (right) (screen dump from VeluxEIC)

To increase natural ventilation by means of stack effect, an extract duct always open has been added to the building (see the roof-top in Figure 15), with a diameter of 0.15 m and a length of 0.6 m.

3.3 Mechanical Ventilation

The building is equipped with a mechanical ventilation system; the air handling unit (AHU) is shown in Figure 22.

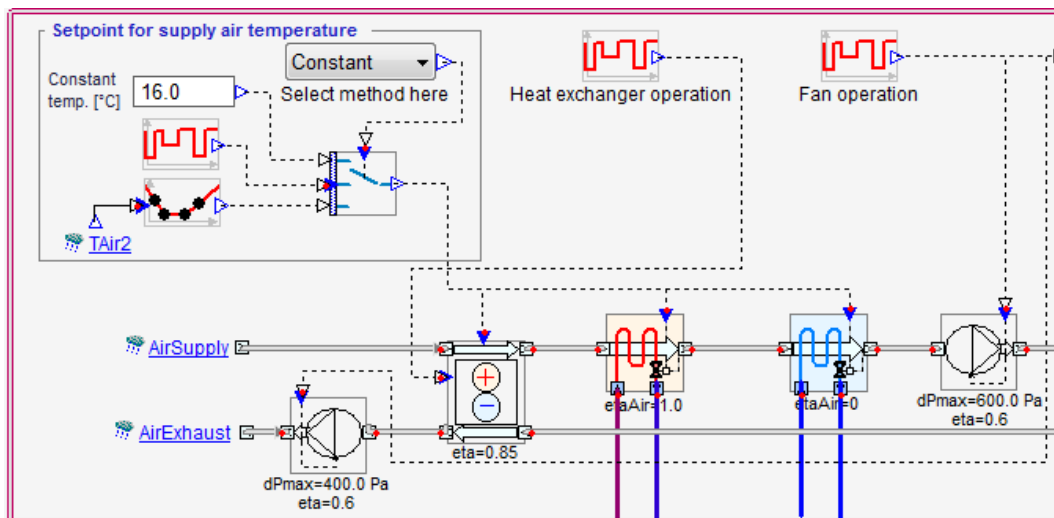

Figure 22 Air handling unit (screen dump from Velux)

It consists of an external supply grid placed at the floor level and an internal extraction grid placed at 2.5 m from the ground, connected through a pipe to the extractive fan. The air supplied from the mechanical system is taken from the outside and sent first to the heat exchanger, having 0.85 of efficiency, and then to the heating coil in which is processed until reach the set point temperature of 16 °C.

At the set-point temperature or higher, the air it is no longer processed and directly supplied in the room. In this way the AHU is used only to supply the air flow rate needed to ventilate the dwelling.

For cold climate as Copenhagen no dehumidification is required and as consequence the coiling coil will be off until there is any dwelling cooling demand that need to be satisfied, which for this climate it is always OFF.

The air-to-air heat exchanger connects the inlet and the outlet pipes to provide heat recovery in order to reduce the energy consumption of the heating coil.

The two fans (supply and exhaust) have different characteristics. The supply fan produces a pressure rise of 600 Pa with an efficiency of 0.6 for a specific fan power (SFP) of 1 kW/(m³s); while the exhaust fan produce a pressure rise of 400 Pa with the same efficiency of 0.6 for a specific fan power of 0.67 kW/(m³s). It was assumed that the supply and exhaust fans don't generate any increase of the air temperature. It has been also assumed that every grid introduces a pressure loss of 5.0 Pa. The values of SFP for the fans were chosen in accordance with European standard EU13779 [40]; even if it is a non-residential building regulations, the lower allowed values of SFP have been taken regarding also to some guideline about low energy building [41].

Fans and heat exchanger operation were scheduled according the occupancy and with some changes in the studied cases that take into account windows opening for natural ventilation.

The AHU grants an air change rate of 0.5 ach that for the building models consists in 70.6 l/s and that are supplied only when the building zone is occupied. The value of 0.5 ach corresponds to the standard EN 15251 [45] for residential building in category III.

3.4 Heating and cooling system

Being a model to study the effect of passive strategies, some simplifications have been done. Some of these concern the heating and cooling systems that have been assumed to be an ideal heater and an ideal cooler.

The ideal heater characteristics are:

- Maximum power of 17.5 kW included the emission losses;
- Generation efficiency of 0.9;
- Emission efficiency of 0.1;
- Distribution losses have been assumed to be equal to 1% of the heat delivered by the plant.

The ideal cooler characteristics are:

- Maximum power of 35 kW included the emission losses;
- COP (coefficient of performance) of 2.4;
- Emission efficiency of 0.1;
- Distribution losses have been set be equal to 0.10 W/m² of floor area.

The two systems only serve the AHU's heating and cooling coils and they are not connected to the building occupant zone. Calculation of the heating and cooling demand was performed through two different proportional controllers PI inside the building zone that take into account all the kWh needed to maintain a certain set-

point. This means that considering the model in realistic way, the total energy consumption it will be a little bit higher because the transportation and distribution heating and cooling losses are not considered.

The heating set-point has been set at 20°C while the cooling at 26 °C. The two set-point temperatures are chosen according to the temperature range for hourly calculation of cooling and heating energy [45], in fact: 20°C is the lower value of the heating temperature range for the indoor temperature of building category II; while 26°C is the highest value of the cooling temperature range. The cooling set point temperature should also guarantee the lower use of the cooling system when taking advantage of the night natural cooling ventilation.

Without real heating and cooling systems connected to the indoor space, a lot of flexibility is given to the model. In this way, the model can be afterwards used to study different coupled heating and cooling systems that can reduce the total energy consumption. For example, considering the cold Nordic climate, the use of a GCHP (ground coupled heat pump) could be a smart idea for future studies.

3.5 Methodology

The software Energy and Indoor Climate Visualizer (EIC Visualizer) from the VELUX Company has been used for running all the simulations. EIC Visualizer is based on the commercial software IDA Indoor Climate and Energy 4 (IDA ICE), a dynamic multi-zones simulation application developed by the Swedish company EQUA Simulation AB. The software has been tested several times against different validation schemes (the validation reports can be found in the VELUX webpage [43]). The main quality of this software is the use of a general-purpose variable time step solver that allows identifying the exact moment in which a change is occurring (e.g. opening or closing of the windows).

All the simulations have been run for a yearlong period with a one-hour time step; so the results refer to all the entire year. Nevertheless, among the year, a night ventilation period has been identified in order to evaluate the indoor environment (i.e. thermal comfort and IAQ). The night ventilation period is the period of the year that starts the day during which the two conditions for the night opening of the windows are met, and ends the last day of night ventilation (i.e. the conditions for the windows opening will never be met again for the rest of the year). The selection of this period has been made because during this the passive strategies, such as night ventilation and solar shading are used to preserve the thermal comfort and the air quality without causing any extra energy consumption.

For each simulation three peculiarities have been examined:

- Indoor Thermal comfort;
- Indoor Air Quality (IAQ);
- Energy consumption.

Indoor Thermal comfort

As stated in the Standards for indoor thermal comfort ([42], [9]), Thermal comfort is the “condition of mind that expresses satisfaction with the thermal environment and is assessed by subjective evaluation”. As a consequence of this definition the thermal discomfort occurs when the indoor environment does not meet the human body’s requirements. There are basically six primary parameters that influence the environment and they are usually divided into two categories:

- Personal factors, because they are characteristic of the occupants, as clothing insulation and activity (metabolic rate);
- Environmental factors, because own environmental characteristics, as air temperature, the mean radiant temperature, air velocity and humidity.

As underlined in the thermal comfort’s definition, humans’ perception and occupants’ expectation takes a relevant role in the evaluation of the thermal comfort. To take into account this effect the European standard EN 15251 ([45]) prescribes two different models to identify the comfort ranges.

Non-Adaptive Model for building equipped with mechanical cooling system; the upper and the lower limits of the three categories are given as static value. These values are collected in Table 8 and are representative of a residential building with more or less sedentary activity (1.2 met).

Table 8 Non-Adaptive Model: threshold values for comfort categories. EN 15251

Category	Operative temperature [°C]	
	Minimum for heating (1.0 clo)	Maximum for cooling (0.5 clo)
I	21 °C	25.5 °C
II	20 °C	26 °C
III	18 °C	27 °C

Adaptive Model for building *not equipped* with mechanical *cooling system*; the upper and the lower limits for each category are given as function of the outdoor running mean temperature. By this model people will freely adapt to the thermal condition inside the dwelling by operating the windows, and by adjusting the personal clothing level. This means that in warm climate, through adaptation, subjective thermal comfort can be reached by using natural ventilation that combined with solar shading will results in a relevant reduction of energy consumption.

These values are collected in Table 9 where:

θ_i is the indoor operative temperature;

θ_{rm} is the running mean outdoor temperature, defined (with a simplified equation 3) as:

$$\theta_{rm} = (1 - \alpha)\theta_{ed-1} + \alpha \cdot \theta_{rm-1} \quad (3)$$

where :

θ_{rm} is the running mean temperature for the considered day;

θ_{ed-1} is the daily mean external temperature for the previous day;

θ_{rm-1} is the running mean temperature for previous day;

α is a constant between 0 and 1 (recommended use of 0.8).

Table 9 Adaptive Model: threshold values for the comfort categories. EN 15251¹

Category	Upper limit	Lower limit
I	$\theta_i = 0.33 \theta_{rm} + 18.8 + 2$	$\theta_i = 0.33 \theta_{rm} + 18.8 - 2$
II	$\theta_i = 0.33 \theta_{rm} + 18.8 + 3$	$\theta_i = 0.33 \theta_{rm} + 18.8 - 3$
III	$\theta_i = 0.33 \theta_{rm} + 18.8 + 4$	$\theta_i = 0.33 \theta_{rm} + 18.8 - 4$

In this study the non-adaptive model will be considered as the use of natural ventilation was combined the mechanical ventilation system.

The standard EN 15251 establishes that during summer condition the temperature off-set can be obtained by means of increased air velocity. The use of increased air velocity makes possible the offsetting of the warm sensation caused by an increased temperature; this happens because the air velocity in a space influences the convective heat exchange between a person and the environment. When the indoor air speed is above 0.2 m/s, it grants an increased heat transfer from the skin that allows an increase in the upper limits of the comfort categories, but, on the other hand, may also cause local thermal discomfort.

Starting from the graph presented in the standard ISO 7730 [9], regarding the effect of air velocity on the temperature, four points were chosen and connected to define the temperature offset trend line. Referring to the velocity-offset curve in figure 23, when mean air temperature is equal to the mean radiant temperature, the chosen points are: (0.2; 0), (0.3; 1), (0.9; 2.75) and (1.2; 3.3).

Pointed out the correlation between air velocity and temperature offset, the *perceived operative temperature* can be defined as the temperature actually experienced by the body.

It is calculated as sum of operative temperature (that takes into account the mean air temperature and the mean radiant temperature) and the temperature offset caused by the velocity inside the occupied zone. The perceived operative temperature is the value used for extract the comfort ranges when an increased air velocity is observed. For example, the mechanical ventilation system does not provide increased air velocity; so for the models equipped with only this kind of ventilation system it was not

¹ These limits apply when $10^{\circ}\text{C} < \theta_{rm} < 30^{\circ}\text{C}$ both for upper and lower limits.[43]

needed to calculate the air velocity inside the zone, whereas for daytime natural ventilation it was. For the indoor mean air velocity calculation the methodology used by Pellegrini ([38], 2012) was adopted too.

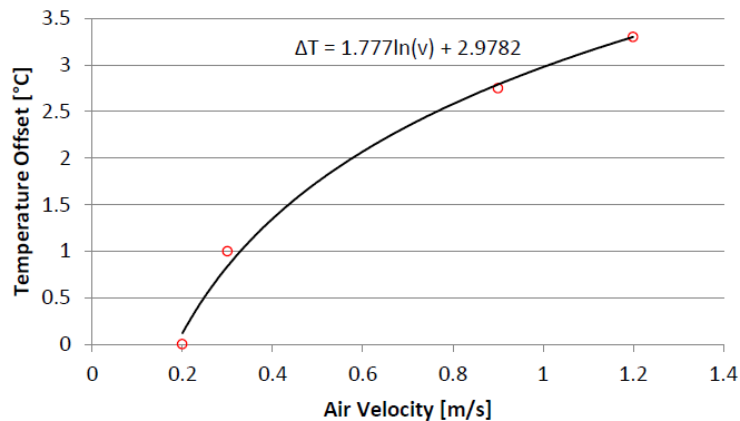

Figure 23 Correlation between air velocities and offset increased temperatures [35]

IDA ICE software was used to calculate the opening air flows top (the air flow rate at the upper part of the window), the opening air flow at the bottom (the air flow rate at the lower part of the window) and the width of windows' opening. The increased air velocity has been calculated only for daytime ventilation (airing schedule, see Figure 21) and not for nighttime because the un-occupied indoor space. An excel sheet has been created for calculating, for each window, the air-inflow as component of out-flow air and the correspondent window's opening according the width and the geometry size. The calculation of the window opening was based on the assumption that the air flow goes only through the cross section normal to the wall surface. The inflow has then been divided in two contributions, axial and transversal, with respect to the building footprint. For each direction two value of air velocity have been calculated: one on the windows threshold and one on the building cross section. Averaging those two components, hour by hour, an approximation of the indoor velocity value has been obtained. The procedure described has been adopted to define the hourly air velocity, and from it the temperature offset through the correlation showed in Figure 23.

Indoor Air Quality (IAQ)

Nowadays, most of the people spent 70-80 % of their time indoor resulting very important the possibility to ensure an adequate indoor air quality. Indoor air quality in residential buildings depends of many parameters and sources like the number of people, emissions from activities, furnishings, and etc. It means that the contaminants released in the air from the internal sources need to be removed or diluted, for health reasons, providing an adequate amount of fresh air from outdoor. In this way, bad indoor air quality symptoms can be avoided.

The parameter chosen as representatives of IAQ is the CO₂ concentration that during the occupancy time is expected to be higher than the outside concentration level, around 350-450 ppm in Copenhagen.

The standard EN 15251 defines four categories of indoor CO₂ concentration level. In this work only the first three categories, listed in Table 9, were taken into account, while 400 ppm was the outdoor CO₂ value set for the simulations.

Table 9 Levels of CO₂ concentration [45]

Category	Allowed CO ₂ concentration above the outdoor level [ppm]
I	350
II	500
III	800

In the same Standard (EN 15251, [45]) indoor air quality can also be defined on required level of ventilation by air change rate (ACH). For the present study in a residential building, the air flow rate for mechanical ventilation system was set equal to 0.5 ach that correspond to 70.6 l/s.

Because of the exploitation of the windows opening during night, the air change rates have been separately calculated between day and night throughout the night ventilation period.

Energy Consumption

The evaluation of the energy consumption, in all the models, takes into account five contributions:

- Heating system;
- Cooling system;
- Mechanical ventilation system (incl. fans and heating-coil consumption);
- Domestic hot water;
- Auxiliary.

The heat recovery contribution was taken into account because of the reduction of the heating-coil consumption in the AHU, later presented in the results.

All energy contributions were expressed in term of *primary energy* used. According to EN 15203 [44], for the electric consumption of the cooling, ventilation system and pumps a coefficient of 2.5 has been assumed, while a coefficient of 1.0 was chosen for the heating system, AHU's heating coil and domestic hot water.

4. BUILDING BEHAVIOR

Low air permeability and good thermal insulation are the main low energy houses' characteristics. If from on one side the increased level of air tightness causes best performance in term of non-wasted energy, on the other side, the lack of an adequate infiltration rate, could create overheating problems even when low is the amount of solar radiation through the windows. In Figure 24 the monthly outside air temperatures for the city of Copenhagen are gathered. Those temperature profiles make impossible to believe that overheating problems may occur in the house sample.

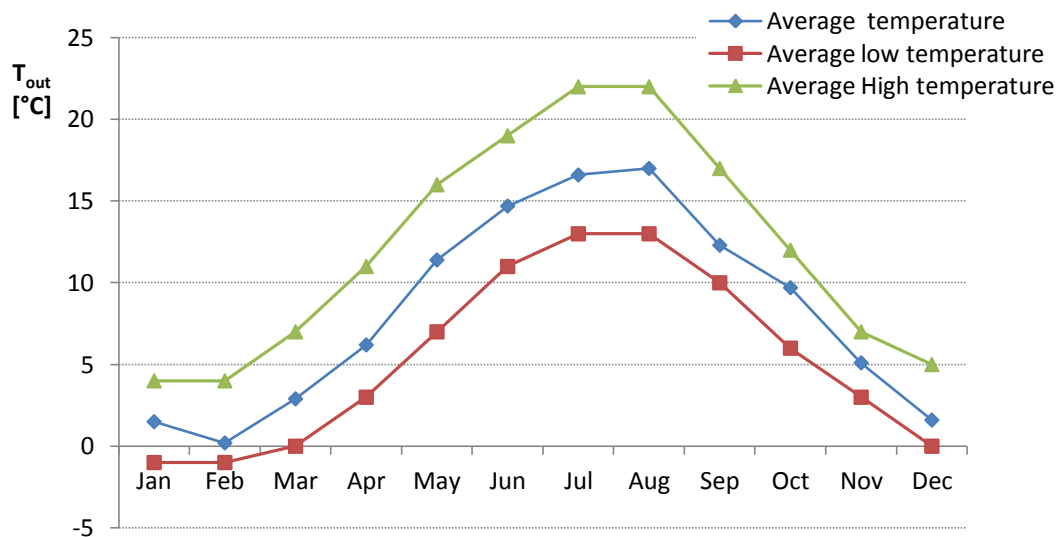

Figure 24 Monthly outside air temperatures in Copenhagen

On the contrary, when a dynamic simulation of the residential building model was performed without implementing any active and passive cooling systems (as solar shading), results showed that issue like *overheating* may occur in low energy buildings. In this first simulated model only the heating and mechanical ventilation systems were working under the conditions expressed in Chapter 3. The model was tested for the climatic condition of Copenhagen that according to Köppen-Geiger climate classification system [46], belong to the oceanic climatic zone and it is representative of Scandinavian climate. By this first simulation it was possible to analyze the free floating indoor air temperature, shown in Figure 25.

When 26°C is the indoor air temperature used as reference, which comply with the highest limit value for thermal comfort in building category II[45], it is evident that in summer time, from June to August, the indoor air temperature is much higher, up to 34 °C.

With more attention on the simulated temperature profiles, higher temperatures of “threshold” (26 °C) also resulted in the mid-seasons time, between April-May and beginning of September.

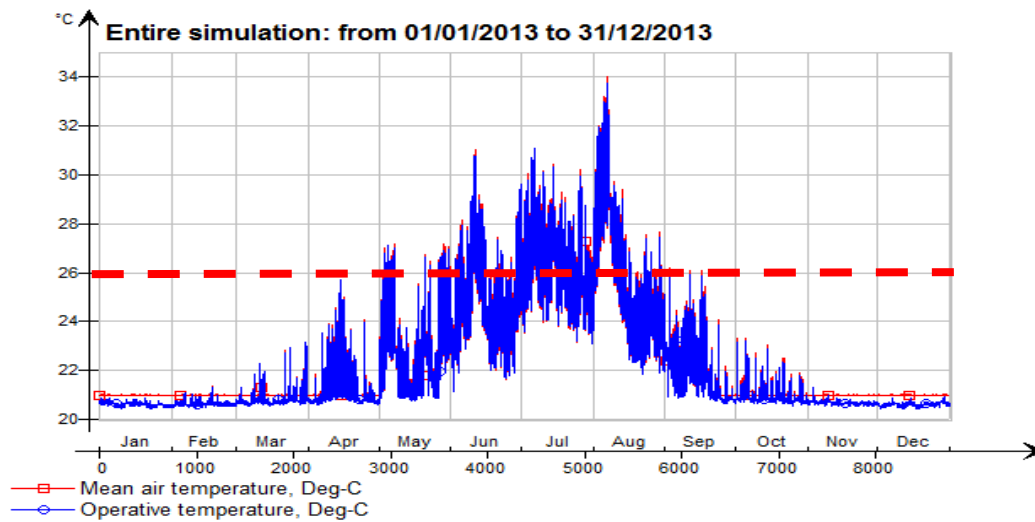
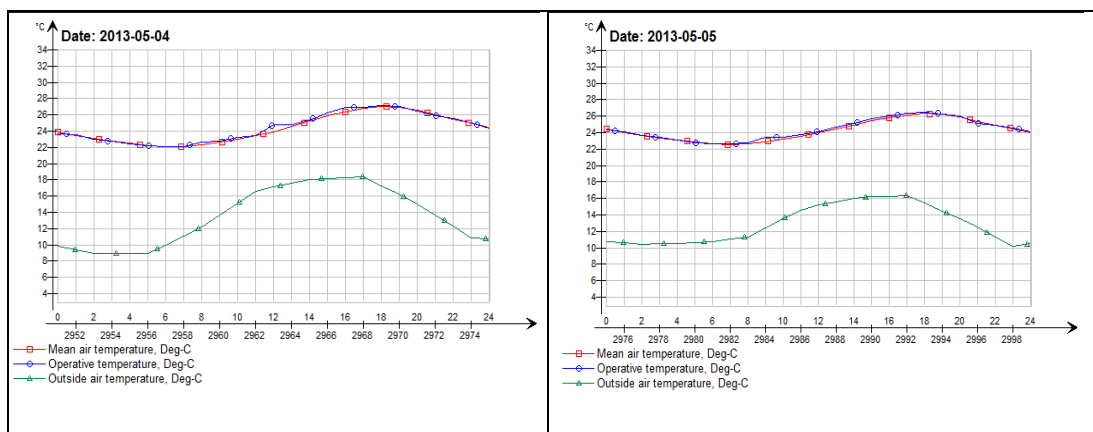

Figure 25 t_o and t_a annual trend of first basic simulated model²

The first simulated model suggested that if the model will be implemented with active cooling system (2nd model), having 26 °C of set-point, it will start working already in the Spring when the temperature difference inside-outside is still higher than 10 °C (see daily detailed trends of temperatures in Figure 26). The second simulated model resulted in extra added energy consumption for cooling, against the main concept of low energy buildings. So far, as prescribes by the European Directive [1], it is necessary to exploit solutions that can grant energy saving without compromising indoor environmental quality. For this reason the effects of passive strategies such *solar shading* and *natural night ventilation* will be evaluated and analyzed in the following simulations.



² The temperatures trend shows the hourly hours values (average of temperatures for each hour).

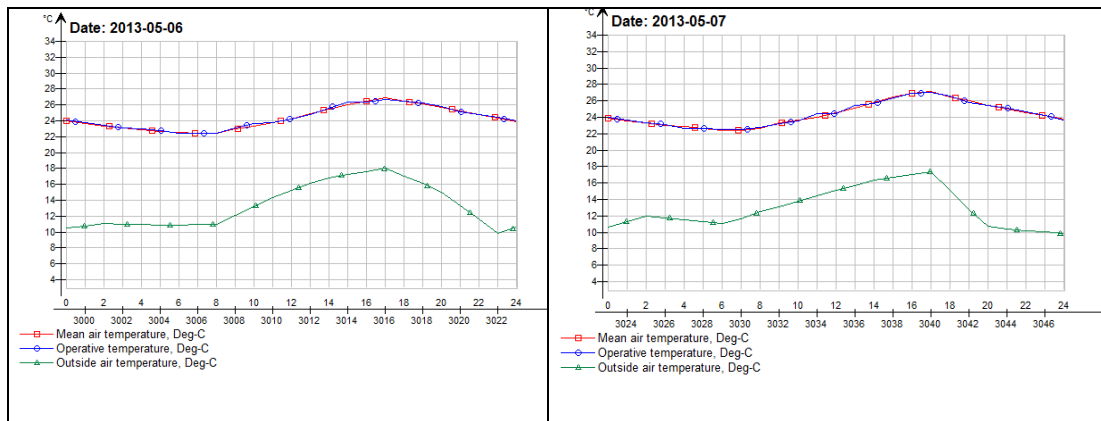

Figure 26 Daily temperature trends of the first simulated building model from Saturday May 4th to Tuesday May 7th.

4.1 Case studies

The first step for performing the building behavior of a residential low-energy house and for calculate his highest total energy demand was the construction of a model supported only by active heating/cooling systems. This model is named M_HC, where:

- “M” stands for mechanical ventilation;
- “HC” stands for heating and cooling systems.

The temperatures set-points for controlling all the systems have been previously described in Chapter 3. Neither solar shading nor night ventilation were considered in this model, and for this reason M_HC was taken as reference to compare with for the subsequent simulations.

Figure 27 shows the low quantity of cooling demand, 10 % of the total demand. This was quite expected for Copenhagen, which as cold climate required half of the total energy demand for heating (45%). The energy demand for ventilation had also a good slice of the total demand, been 29%. It happened because the outside air, supplied by the fan, had to be processed before being introduced into the indoor occupied zone. If the pre-heating of air change rate wouldn't be performed, thermal discomfort risk may occur especially during the winter period. For this reason, AHU's heating coil demand was 71% of the total ventilation demand with only 29% for fans' operation.

The operation of the cooling system has effect on indoor air temperature. In Figure 28 is visible how, when the inside conditions make undeniable the cooling system operation, the air temperature has the maximum value of 26°C, coherently with the temperature set-point for cooling. Nevertheless, during the warmest period of the year, the *operative temperature* was on average 1 °C higher than the mean one, as result of higher radiant heat contribution. In this simulated model no any type of solar shading were implemented, so the solar radiation, that crosses the glazed surface

could cause the increase of radiant heat exchange between all interior surfaces, both opaque and glazed.

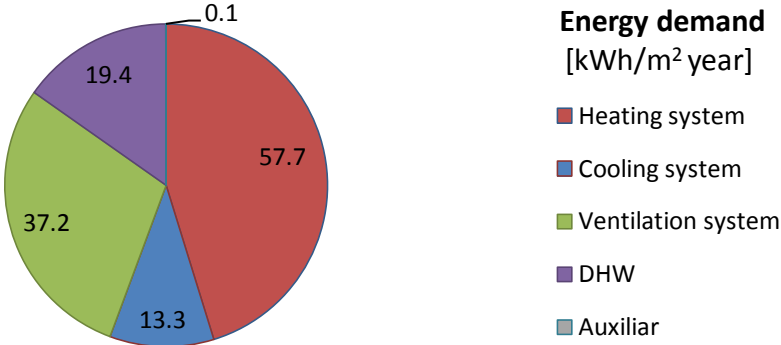

Figure 27 Primary energy demand for M_HC model

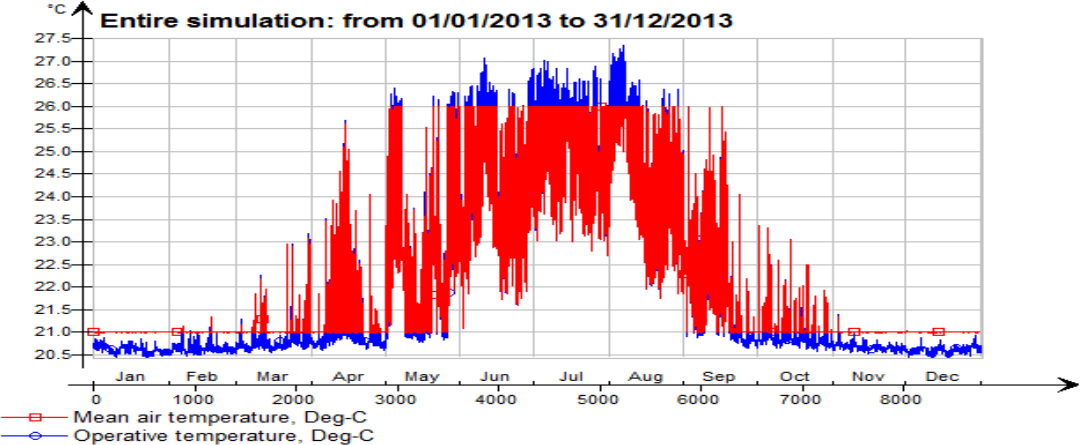

Figure 28 Annual temperatures trend for M_HC model

Next step of this study was to consider the effect of solar shading and natural night ventilation, both individually and coupled, including also the exploiting heat recovery ventilation. The purpose of this last implementation was to find out the percentage of energy saving that can be reached without compromising at the same time thermal comfort and IAQ parameters.

Three different case studies were analyzed with the following settings:

- M_HC_S: basic simulated building model M_HC implemented with solar shading (passive strategy) use, under the condition expressed in paragraph 3.2 (“S” stands for solar shading use);
- M_HC_Na: basic simulated building model M_HC implemented by natural night ventilation only through the windows opening, under the condition expressed in paragraph 3.2. (“Na” stands for natural night ventilation automat-ed). To prevent overcooling during the night, an automatically proportional control on windows opening was integrated (paragraph 3.2);

- M_HC_SNa: basic simulated building model M_HC implemented with both passive strategies, solar shading and night cooling ventilation. (“SNa” stands for solar shading and natural night ventilation automated).

Actually, because of the implementation of heat recovery ventilation (HRV), the models analyzed are six including M_HC_S_HRV, M_HC_Na_HRV, and M_HC_SNa_HRV, which represent the previous explained three models integrated by HRV.

Table 10 presents a summary of used passive strategies, for each case study.

Table 10 Summary of case studies characteristics

Case studies	SOLAR SHADING	NATURAL NIGHT VENTILATION
M_HC	NO	NO
M_HC_S	YES	NO
M_HC_Na	NO	YES
M_HC_SNa	YES	YES

4.2 Results

This section gives a general overview of some obtained results. Particular attention is focused on energy demand, thermal comfort and indoor air quality.

4.2.1 Energy demand

As stated in paragraph 4.1 the M_HC cooling demand was 13.3 kWh/m² year. Figure 29 shows that using passive strategies important energy reduction can be obtained. 96% using solar shading while only 47% using natural night ventilation alone. The cooling energy saved turn into 98% if both passive strategies are used at the same time. Nevertheless, combining both strategies the cooling demand is almost nullified being only 0.2 kWh/m² year.

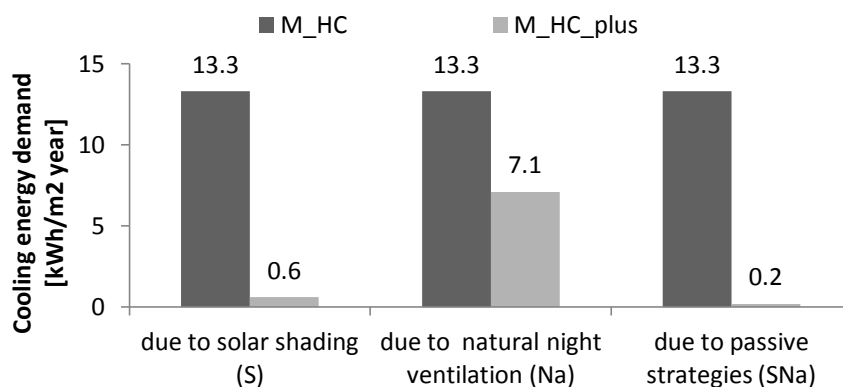

Figure 29 Cooling demand when passive strategies are used (plus) or not (M_HC)

Heat recovery ventilation also allows good performance and (referring to total energy demand) energy saving percentage that varies between 21% and 23% from case to case (Table 11 and Figure 30).

Table 11 Total energy demand of all case studies with and without heat recovery ventilation

Case studies	Total Energy Demand without HRV [kWh/m ² year]	Total Energy Demand with HRV [kWh/m ² year]	Energy Saving [kWh/m ² year]	Energy Saving %
M_HC	127.7	101.3	26.4	21%
M_HC_S	116.4	90.0	26.4	23%
M_HC_Na	118.7	93.8	25.0	21%
M_HC_SNa	115.1	89.0	26.1	23%

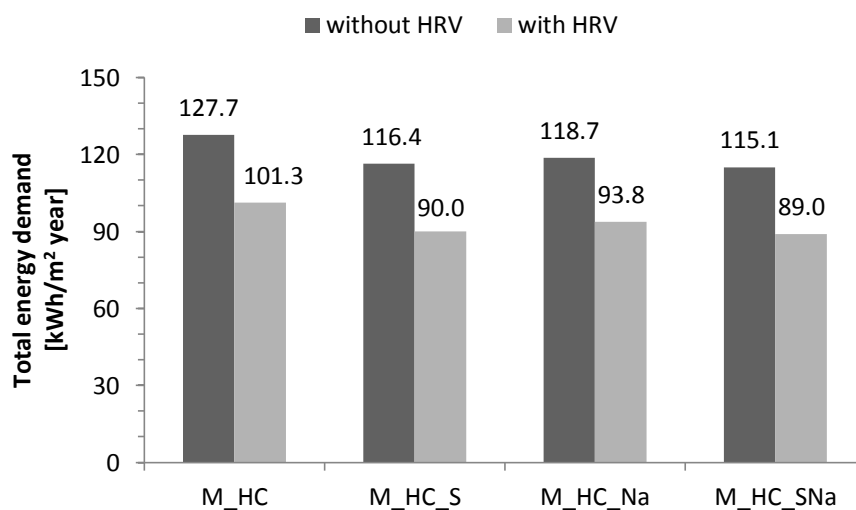

Figure 30 Total energy demand for the case studies with and without HRV

Figure 31 shows the energy demand of heating, cooling and ventilation systems for the different case studies. What it is important to highlight is the double reduction of energy demand: one due to the passive strategies and the other to the heat recovery ventilation (as expected). By exploiting heat recovery 72% of energy can be saved (M_HC_SNa_HRV).

Finally, the case study implemented with both passive strategies and with HRV resulted in the highest primary energy save equal to 30%.

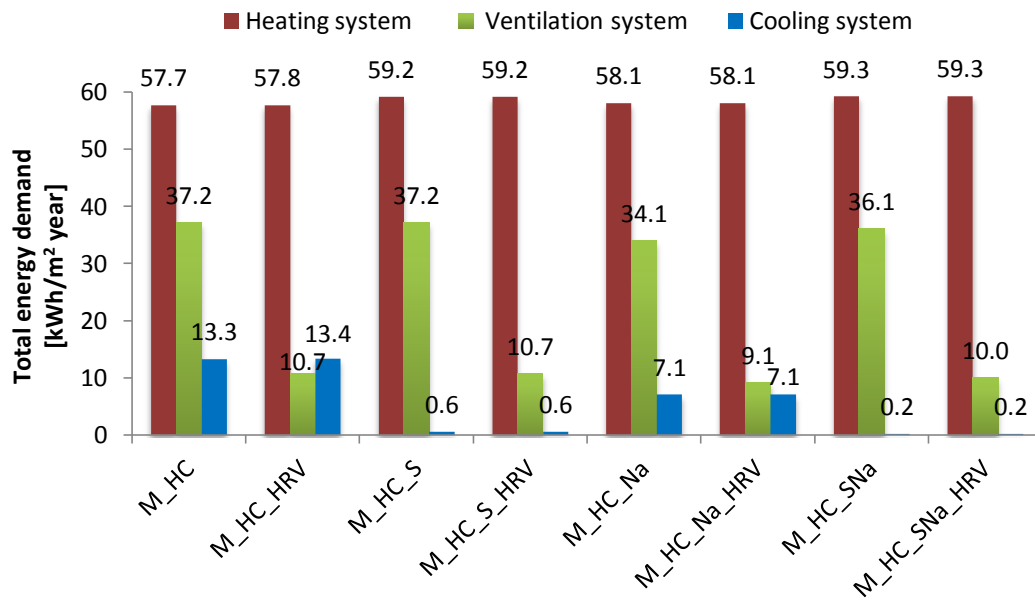
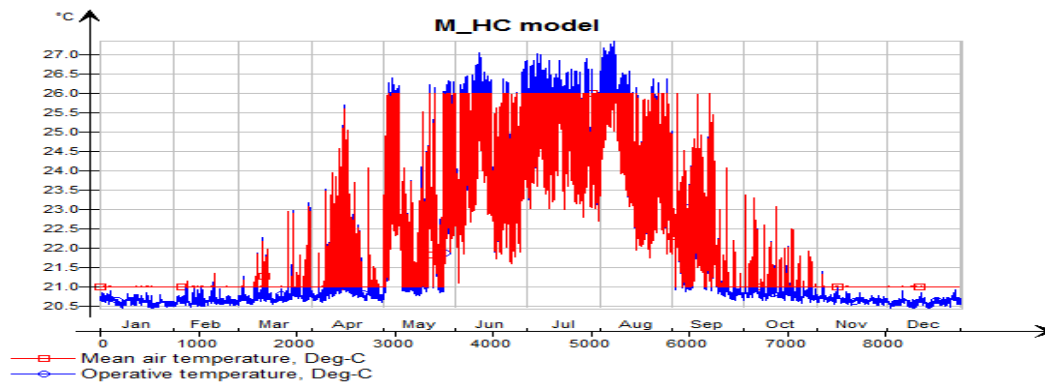

Figure 31 Distribution of the total energy demand between the three systems

4.2.2 Thermal comfort

When analyzing the resulting indoor thermal comfort conditions, it is worthwhile to look at the annual temperature trends of the case studies reported in Figure 32.



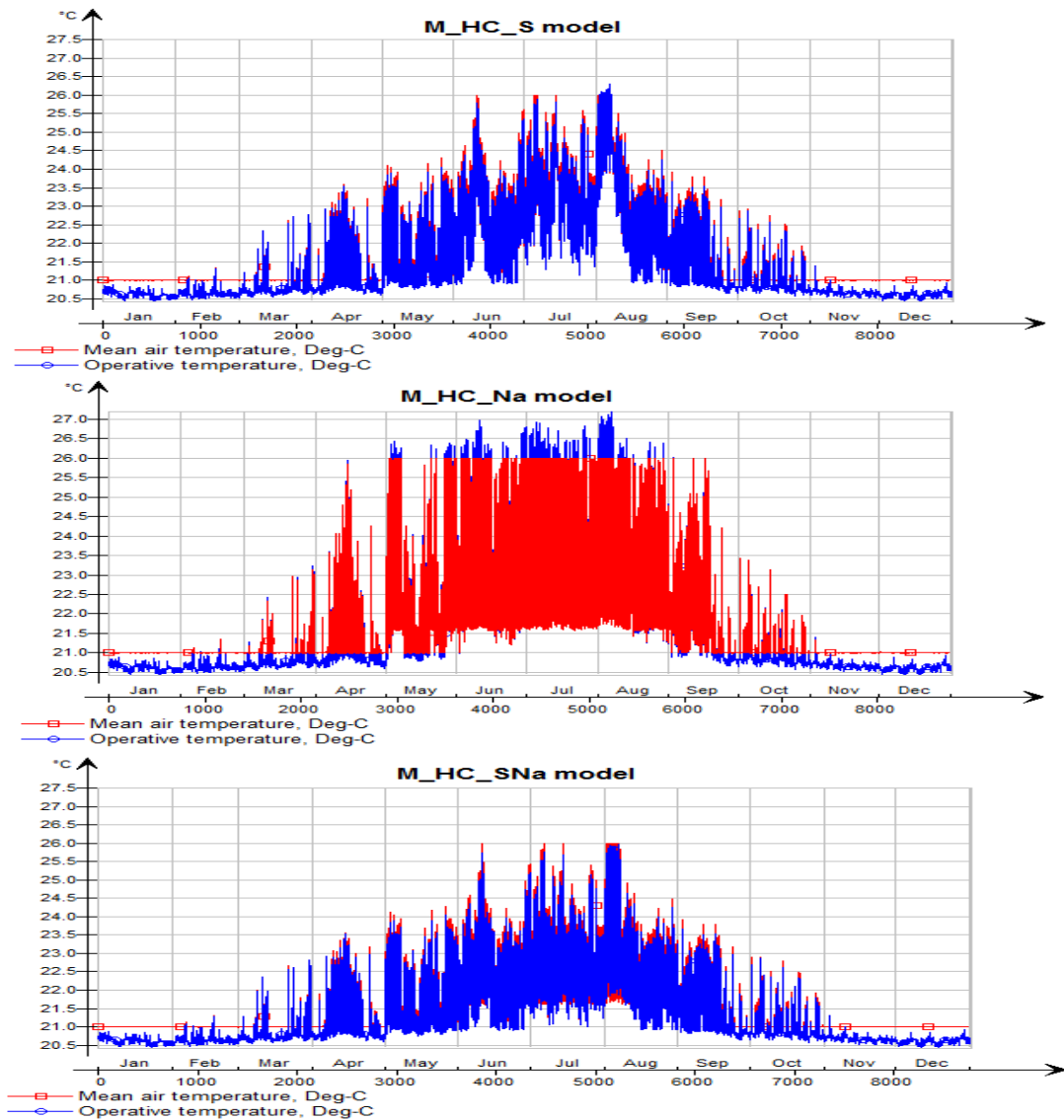

Figure 32 Annual indoors temperature trends for the case studies M_HC, M_HC_S, M_HC_Na and M_HC_SNa.

The temperatures trends of M_HC_S model showed that the control on the solar radiation penetration through the windows decreased the operative temperature data to the air temperatures, confirming the assumption earlier made. As matter of the fact, the two profiles match each other (between June and August), except for the warmest weeks at the beginning of August when anyway the differences are lower than 0.5°C. As consequence, in M_HC_Na model, the temperatures difference is again noted, showing the inefficiency, in term of global building behavior, of using natural night ventilation passive strategy alone. This “inefficiency” concept is clearly shown in Figure 33 where the monthly temperature trends of June, July and August are reported and compared with the case study of M_HC_SNa model.

An average operative temperature decrease of 3.5 °C was the effect of nighttime windows opening for natural ventilation during summer (M_HC_Na). The average

temperature at 7 a.m. was equal to 21.4°C ³. However the benefit of a low temperature in the morning was nullified if no solar shading is used. Solar loads cause an increase of the temperature during the day higher of the set-point temperature requiring the use of the cooling system. This not happens if both the “cooling” passive strategies are applied. In fact, natural night cooling creates a drop in temperature and solar shading keeps the benefits modulating the solar radiation that enters into the building.

Profits in the coupled use of the passive strategies are observed also during the mid-season months, especially in May and September, when in M_HC case study the set-point of 26°C was reached while in M_HC_SNa the temperature was always under 24°C .

In a qualitative way, just having a look to the temperature tendency, it is possible to conclude that the best thermal comfort condition can be reached with the simulated condition of M_HC_SNa, confirmed by the thermal comfort categories of EN 15251. Figure 34 show that M_HC_SNa is the only simulated model that guarantees 100% indoor environment of category II for all year around.

The implementation of the heat recovery ventilation seems to not invalidate the performance of any models; there is only a little variation of the percentage for the reference model.

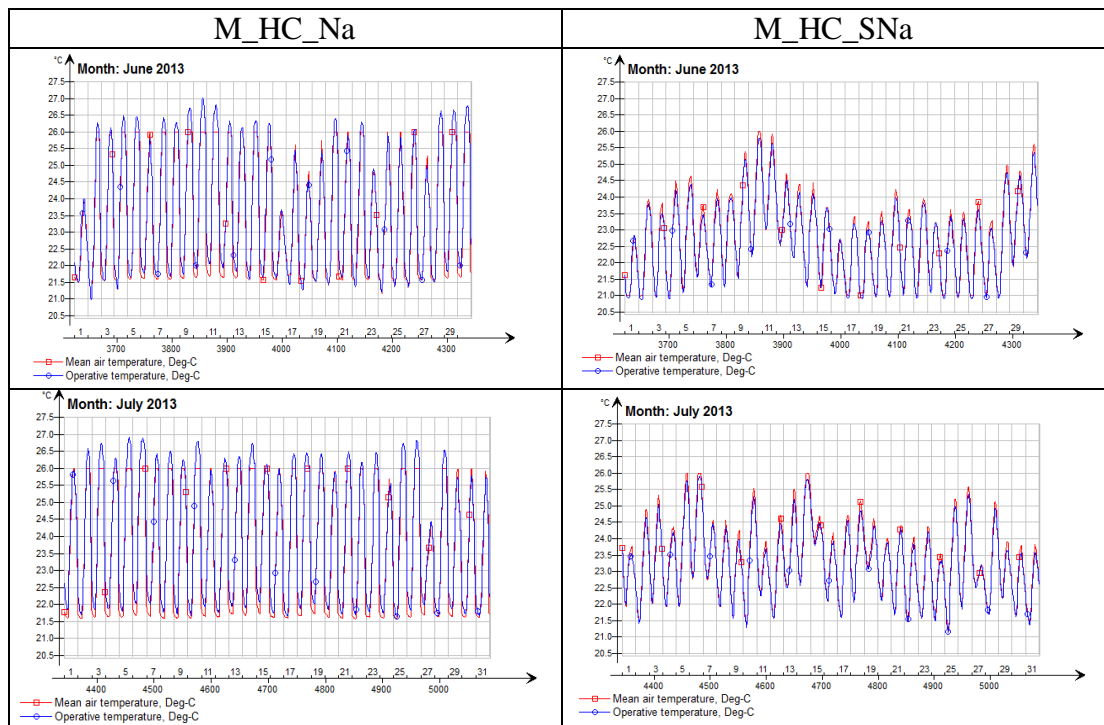

³ Average temperature value at 7a.m., from June to August, for M_HC_Na case study

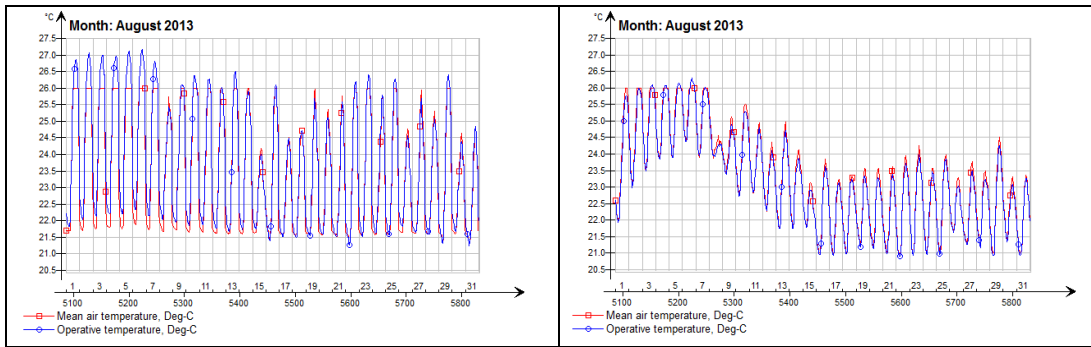

Figure 33 Monthly temperature trends for M_HC_Na and M_HC_SNa models in summer

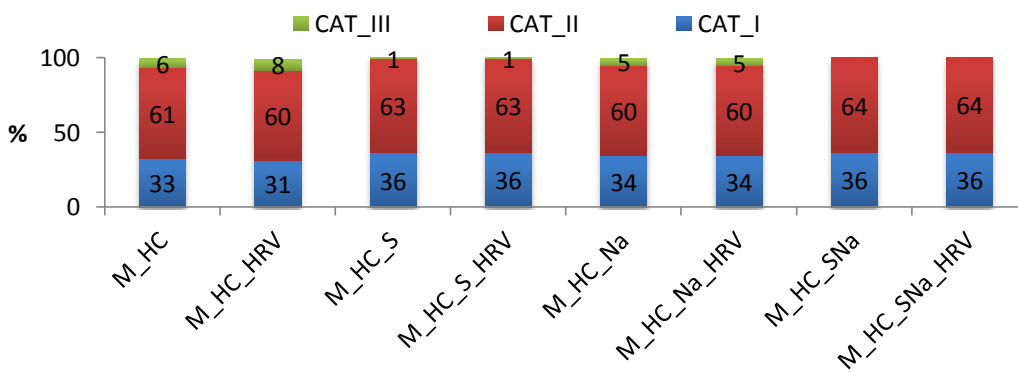

Figure 34 Thermal comfort throughout the year valuated according to the EN 15251 non-adaptive model

A specific period among the year has been considered to better understand the effect of passive strategies on thermal comfort during summer: *night ventilation period*. It starts from the day in which the conditions for the opening of the windows during night are met and it ends when they are not anymore. The only two models that exploit night ventilation are M_HC_Na and M_HC_SNa. The *night ventilation period* was different for the two case studies:

- For M_HC_Na, from April 12th to September 17th, 158 days over 365 (43% of the year);
- For M_HC_SNa, from May 4th to August 29th, 117 days (32% of the year).

The *night ventilation period* is shorter for M_HC_SNa simulation model, resulting in indoor air temperature lower than 23°C at 10 p.m.. The obtained thermal comfort categories for those two models are shown in Figure 35 and Table 12.

As expected, the combined use of both passive strategies results the best solution to guarantee 100% of category II, following also for 84% in category I.

One aim of this work is to analyze and prove that passive strategies can avoid the overheating unpleasant issue that may occur in low energy building. There are many documents that refer to overheating problems and they give different definitions. For example according to CIBSE [49] different operative temperatures threshold should

be taken as reference when the overheating problem is analyzed. They state that less than 1% of the occupancy hour should be over 28°C in the living area while this threshold is lowered till 26°C for bedrooms. CIBSE gives also general summer indoor comfort temperatures for non-air conditioned dwellings. Living areas should have an operative temperature of 25°C while bedrooms equal to 23°C because sleep quality may be affected over 24°C.

Table 13 shows the number of hour in which the operative temperature inside the building zone is higher the set point. The range of temperatures thresholds varies between 25°C to 28°C to have a global knowledge of how the building behaves.

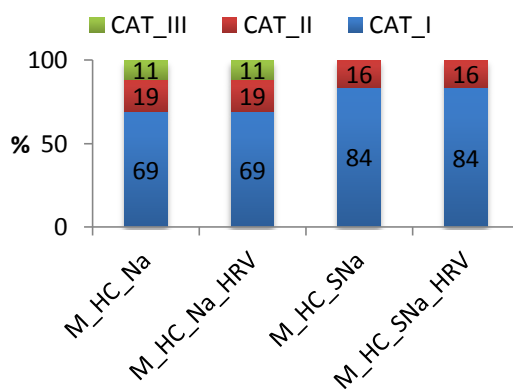

Figure 35 Thermal performance during the night ventilation period according to EN 15251 Non-adaptive model

Table 12 Thermal performance during the night ventilation period according to EN 15251 Non-adaptive model

Case studies	CAT_I [%]	CAT II [%]	CAT_III [%]
M_HC_Na	69	89	100
M_HC_Na_HRV	69	88	100
M_HC_SNa	84	100	100
M_HC_SNa_HRV	84	100	100

The building model is a unique one zone so it results hard to give only one threshold temperature reference. When no mechanical cooling is working (M_H model) the percentage above 28°C is 4% (253 hours over 6411 hours of occupancy time), while lower is in all other simulated models. Actually, with the use of the combined passive strategies, the temperature is always below 26°C, the highest temperature allowed in thermal comfort category II. This means, as proved with the qualitative analysis of the temperature trends, that the overheating problem can be prevented maintaining a good thermal environment for all year.

In Figure 36 the percentages of the hours in which the operative temperature is higher to the reference temperatures are shown. According to the occupancy schedule, the hours in which the building is occupied are 6411 over 8760, corresponding to 73% of the year in which users are in the dwelling. Finally, only 1% of the occupancy hours can occur in t_o higher than 25°C in a building with M_HC_SNa systems.

Table 13 Number of hours in which the operative temperature is over the different threshold during the occupancy time

Case studies	T>25°C [h]	To>26°C [h]	To>27°C [h]	To>28°C [h]
M_H	975	660	411	253
M_HC	752	391	14	0
M_HC_S	130	20	0	0
M_HC_Na	536	313	5	0
M_HC_SNa	80	0	0	0

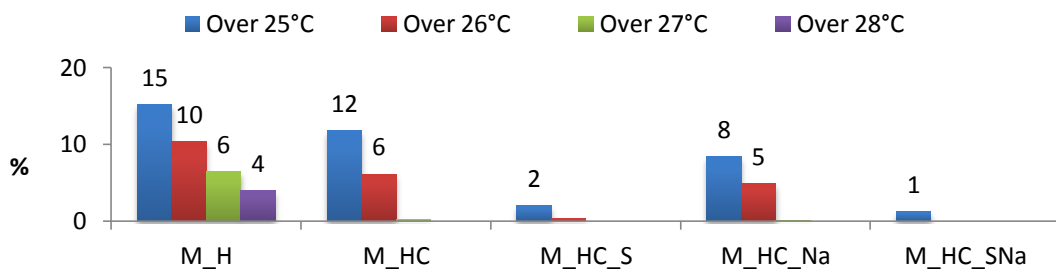

Figure 36 Percentage of hours in which the temperature is over different thresholds during the occupancy time

In Figures 37 and 38 the temperatures trends for the two warmest weeks of the year are presented. The first week, from July 29th to August 11th, had different operative temperature, at least 1°C, between M_HC_Na and M_HC_SNa case studies. In the second week, the cooling effect due to the natural night ventilation is clearly showed. From April 29th to May 5th and from September 9th to September 15th is more visible the effect of the solar shading to prevent overheating in the mid-season. The operative temperature difference between M_HC_Na and M_HC_S models was up to 3°C, so high that it can't be ignored.

From the temperatures trends it is plausible to see how the use of the natural night ventilation makes possible to have temperature below the threshold at night suggested by CIBSE. Passive strategies' use resulted in the best solutions to achieve comfortable conditions for day and night, and to preserve the building from the *overheating* issue in summer and in mid-season period.

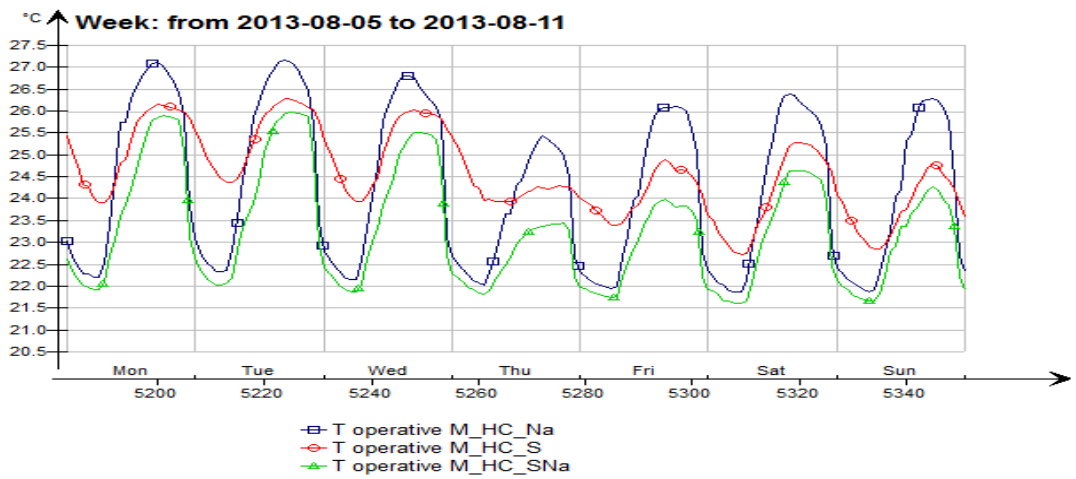
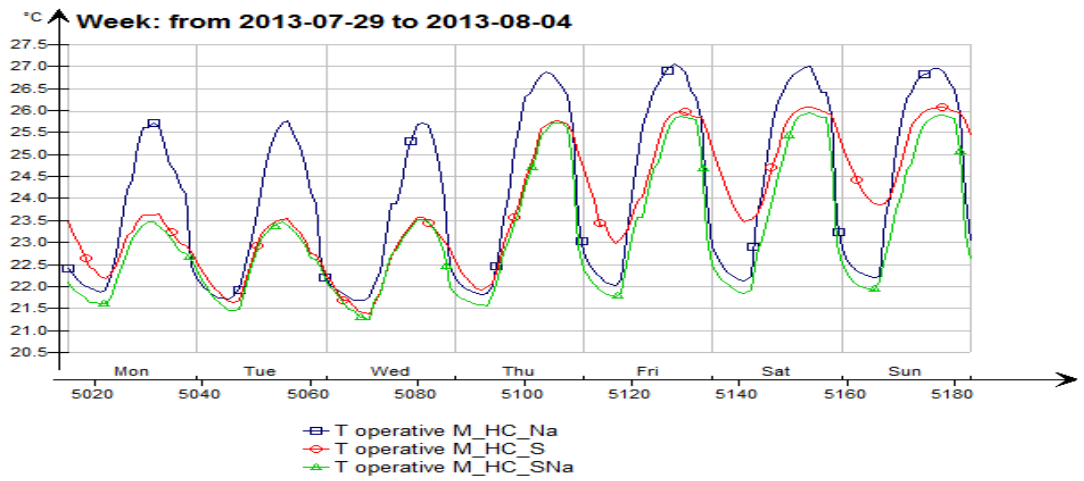
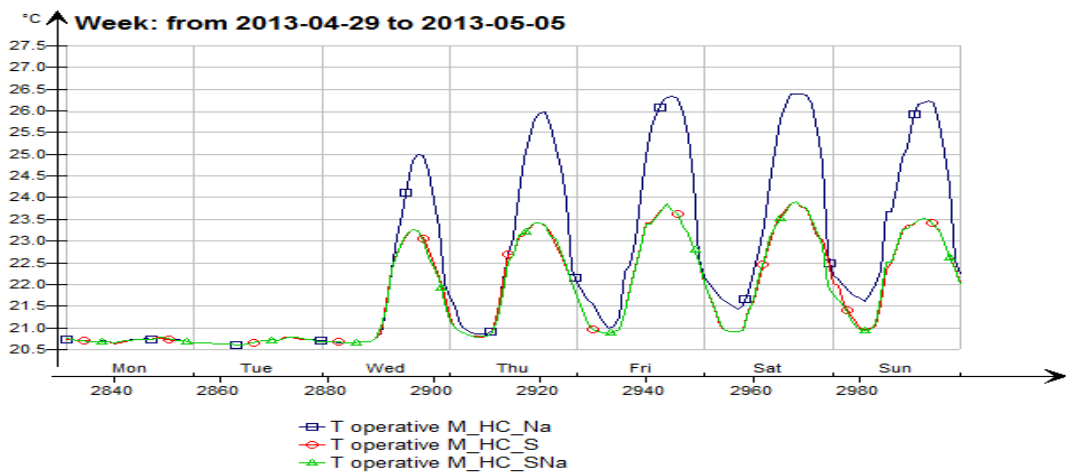

Figure 37 Temperatures trends of M_HC_Na, M_HC_S and M_HC_SNa models during the the two warmest week of the year (from July 29th to August 11th)



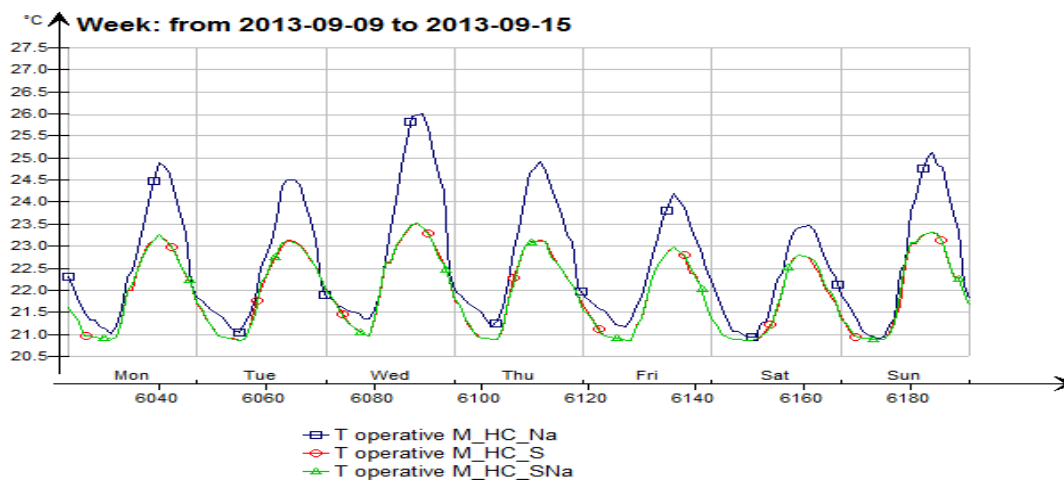

Figure 38 Temperatures trends of M_HC_Na, M_HC_S and M_HC_SNa models during the two weeks in the mid-season; one from April 29th to May 5th and the other one from September 9th to September 15th

4.2.3 Indoor air quality

The IAQ is remarkably high in each studied solution. All simulated models achieved 100% category I for the whole year (Figure 39) and 99% during the natural *night ventilation period* (Figure 40) This result brings to the conclusion that the windows opening during the night does not affect in a heavy way the indoor air quality, lowering the reference value for only 1%.

Also in this case, like for the thermal comfort, the implementation of the heat recovery ventilation does not cause difference in the performance.

To better understand the influence of natural ventilation, the air change per hours, by day and night, at the occupancy time was calculated. Because of the difference in length of the *night ventilation period* for the two analyzed models the longest M_HC_Na was considered as reference model. Results, Table 14 and Figure 41, show that the effect of opening the windows during the night has a big influence on the air changes per hours varying from 0.6⁴ ach (M_HC) to 1.3 ach.

⁴ The value includes 0.05 of infiltration.

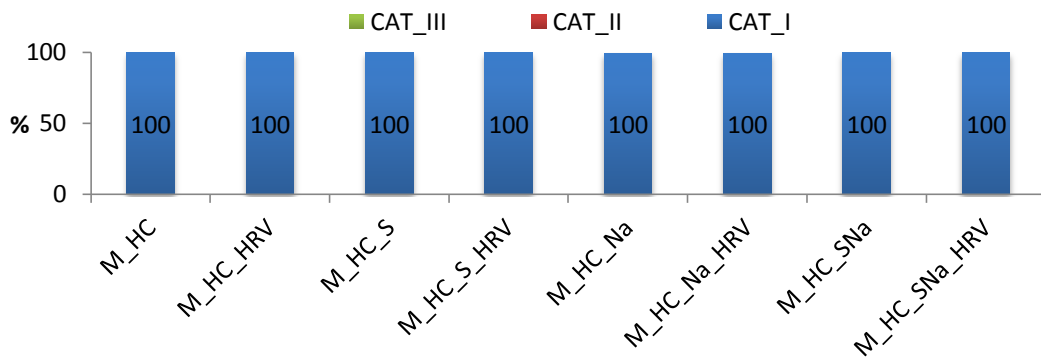

Figure 39 IAQ for the whole year evaluated according to the EN 15251 for the eight models

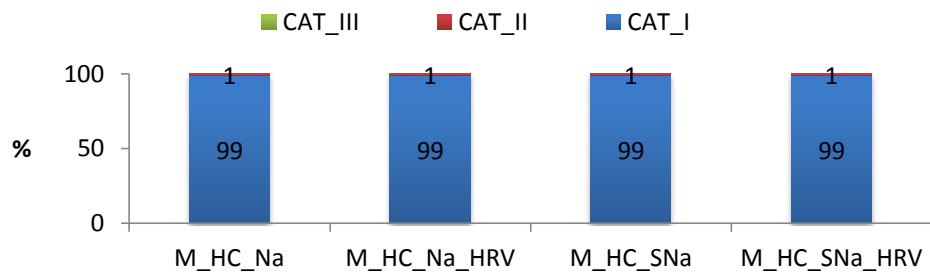

Figure 40 IAQ during the natural night ventilation period

Table 14 Air change per hour divided between daytime and nighttime during the *night ventilation period*

Case studies	ACH Night [vol/h]	ACH Day [vol/h]
M_HC	0.6	0.5
M_HC_HRV	0.6	0.5
M_HC_S	0.6	0.5
M_HC_S_HRV	0.6	0.5
M_HC_Na	1.3	0.5
M_HC_Na_HRV	1.3	0.5
M_HC_SNa	1.3	0.5
M_HC_SNa_HRV	1.3	0.5

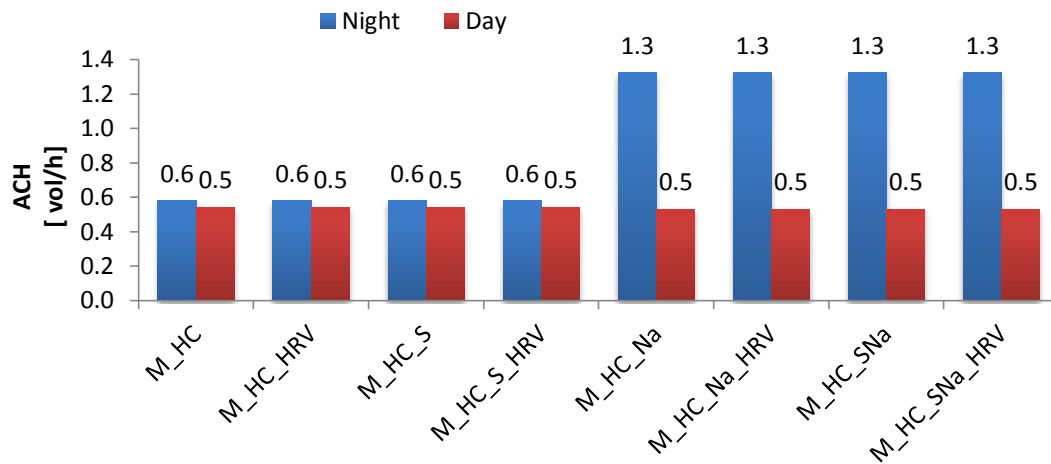

Figure 41 Air change per hour divided between daytime and nighttime during the *night ventilation period*

4.3 Effect of Behavior ventilation

The model implemented with the simultaneous application of passive strategies complies with: reduction of energy demands, improvement of thermal comfort and good indoor air quality. However global suitable performance, no freedom to the hypothetical building inhabitants, in opening the windows during day, should be evaluated.

When accounting the free windows opening by users, a new simulation model was built: M_HC_SNa_w_HRV. It consists on the model that account on the use of natural night ventilation and solar shading, with heat recovery, with the additional signal that allows the occupants to open the windows for 15 minutes in the morning and in the afternoon. This kind of natural ventilation strategy has been earlier designed by Pellegrini [38] after he observed the aggressive performance of other daytime ventilative strategies. Not all the windows were interested by this control ventilation; only type B and C. According to an ISE study [47], the users behavior regarding the manual control of windows in an office building for an entire year was dedicated to open for a short period (15 minutes) large area windows in specific moments of the day (at the morning arrival and after lunch break). These results have been adapted for the residential building model by a signal that open the windows in the early morning (from 7:00 a.m. to 7:15 a.m.), and in the late afternoon (from 5:00 p.m. to 5:15 p.m.), when back home from work. During the daily time of windows opening the increased air velocity was calculated according the methodology described in paragraph 3.5.

The aim of this new case study is just to see how the possible human behavior can impact on building energy performance and indoor environment. The period of the year with the daytime ventilation was set from March 21th to October 21th.

No any effect was found on regard the energy demand, still equal to 88.9 kWh/m² years. Only improvements, apparently not needed, could be found in terms of indoor air quality that stays in category I. While interesting resulted the thermal comfort conditions with an increase of 1% in category I. In Figures 42, 43, 44 and Table 15 are shown the results.

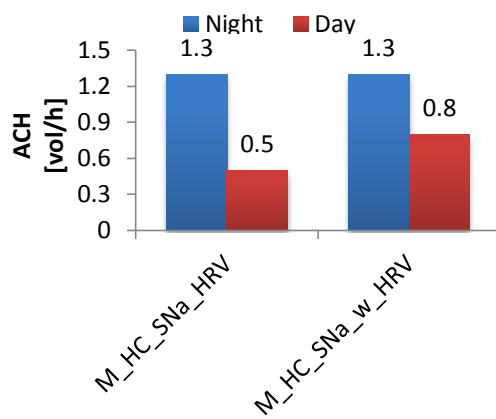

Table 15 Air change per hour divided between daytime and nighttime during the night ventilation period

Case studies	ACH	ACH
	Night [vol/h]	Day [vol/h]
M_HC_SNa_HRV	1.3	0.5
M_HC_SNa_w_HRV	1.3	0.8

Figure 42 Air change per hour divided between daytime and nighttime during the night ventilation period

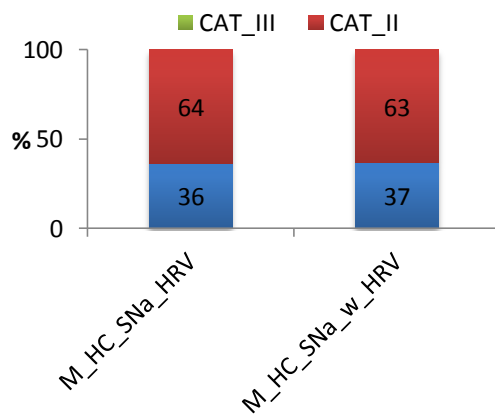

Figure 43 Thermal Comfort among the year evaluated according to EN 15251

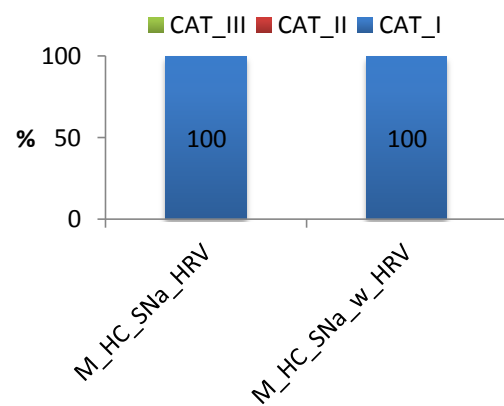

Figure 44 IAQ among the year evaluated according to En 15251

4.4 Does the missing cooling system impact on thermal comfort?

As proved in paragraph 4.2.1, that applying solar shading and natural night ventilation, the cooling demand can be lowered by 98 %. Considering that after this reduction, the cooling demand is just 0.2 kWh/m² year, it makes sense wondering if it is possible to spare the use of a cooling system. To answer this question a new case study has been analysed: M_H_SNa_HRV. It is a model with the same characteristics of M_HC_SNa_HRV with the absence of the cooling system. The aim is to understand if the cooling system is compulsory for granting good thermal condition or if it can be easily replaced exploiting others passive strategies.

Figure 45 shows how the absence of a cooling system (M_H_SNa_HRV model) reflects in just a 1% loss in category II. This light drop can be undoubtedly tolerate considering that this result comes from the two operative temperatures trends that are different only during the warmest two weeks of the year (from July 29th to August 11th), details showed in Figure 46.

So bearing this slight discomfort during those two weeks, an important saving can be obtained in term of total installation's cost and 0.3% of energy from cooling demand (see Figure 47).

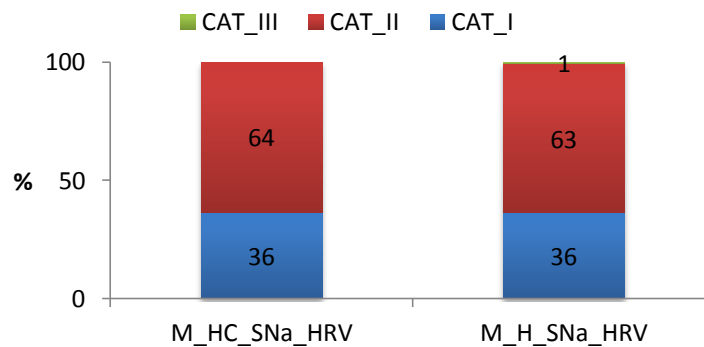
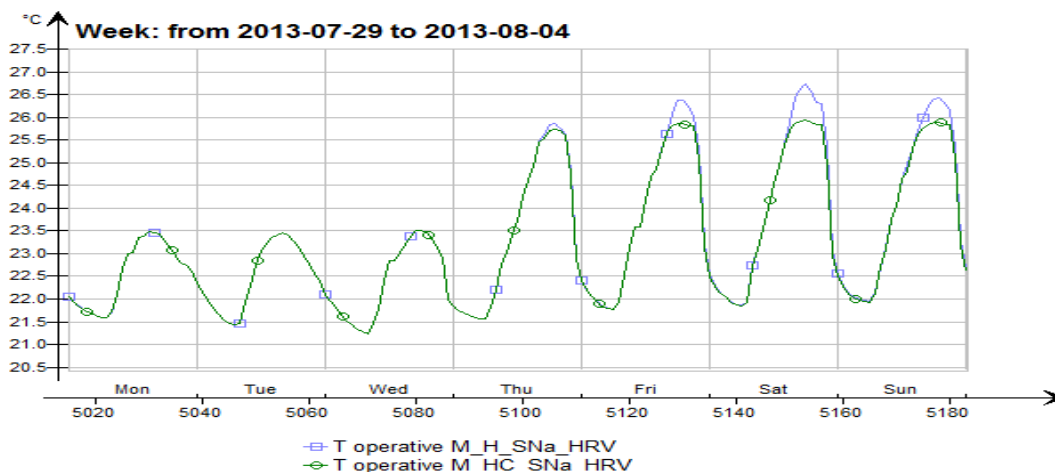

Figure 45 Thermal comfort among the year according to EN 15251



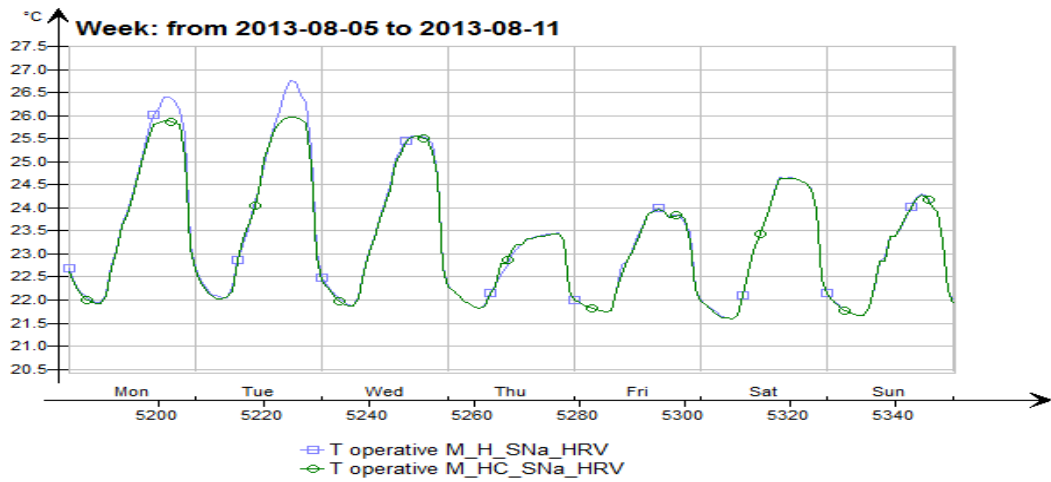

Figure 46 M_HC_SNa_HRV and M_H_SNa_HRV operative temperature tendencies during the two warmest weeks of the year

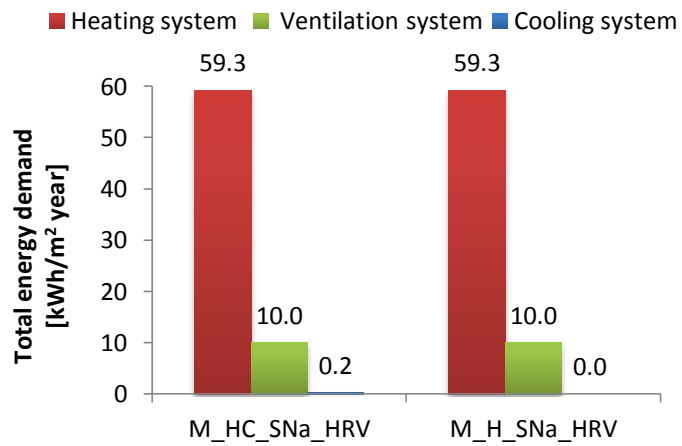

Figure 47 Comparison in term of energy demand for M_HC_SNa_HRV and M_H_SNa_HRV models

5. TOWARD NEARLY ZERO ENERGY BUILDINGS

The results achieved till this dissertation's point show the importance of the passive strategies in lowering the cooling demand, solving in an environmental friendly way the unpleasant over heating's problem. Although the cooling demand is almost nullified, the total energy demand is beyond the latest Danish Building Regulation BR 10 guidelines [48]. The BR 10 came into force in January 2011; in order to encourage the development of more energy efficient construction. It includes a 'class 2015' low energy buildings definition in term of total energy demand. The performance framework is (equation 4):

$$E_d = (30 + 1000/A) \quad (4)$$

where A is the heated floor area and E_d is expressed in term of kWh/m² year

For building model, considering 176 m² of heated floor area, the energy demand should be close to 35.7 kWh/m² year

If a look is given again to Figure 31 that shows the systems energy demand distribution, the heating demand has a predominant role in determining the final energy demand. To reach the target this demand needed to be reduced. Starting from this consideration some changes were done in the building structure

Walls and roof insulation has been doubled in thickness while for the floor incremented by 70% of the initial value. Even if this new values will grant a thermal losses heavy reduction, they are not the values suggested by the regulation. The U-value for walls, roof and floor should be even lower. Nevertheless, the used values were considered in the perspective of further applications of this building model to other European climatic conditions. If Mediterranean climate is considered, the very high building insulation could be seen far away from the realistic one. For that reason, the chosen values resulted to be a good comprise.

The new thermal proprieties of the building envelope (U-value) are:

- External walls: $U=0.18 \text{ W/m}^2 \text{ K}$; $s=0.51 \text{ m}$;
- Floor: $U=0.20 \text{ W/m}^2 \text{ K}$; $s=0.5 \text{ m}$;
- Roof: $U=0.19 \text{ W/m}^2 \text{ K}$; $s=0.41 \text{ m}$.

Building stratigraphy is collected in Table 16, 17 and 18.

Table 16 WALL stratigraphy from inside to outside

Material	thickness [m]	heat conductivity [W/(m K)]	density [kg/m ³]	specific heat [J/(kg K)]
internal plastering	0.01	0.7	1400	850
concrete layer	0.2	1.7	2300	1000
mineral wool	0.2	0.04	30	850
outer layer	0.1	0.99	1800	850

Table 17 FLOOR stratigraphy from top to bottom, where top is internal

Material	thickness [m]	heat conductivity [W/(m K)]	density [kg/m ³]	specific heat [J/(kg K)]
stone	0.01	3	2700	880
concrete layer	0.2	1.7	2300	1000
insulation	0.17	0.04	50	850
concrete ENISO13792	0.1	2.1	2400	850
acoustic board	0.02	0.06	400	840

Table 18 ROOF stratigraphy from top to bottom where the top is external

Material	thickness [m]	heat conductivity [W/(m K)]	density [kg/m ³]	specific heat [J/(kg K)]
external layer	0.01	0.23	1500	1300
insulation	0.2	0.04	50	850
concrete layer	0.2	1.7	2300	1000

All windows have the same U-value of 0.528 W/m²K with the exception for the pivoting windows at the roof equal to 0.639 W/m²K.

The window glasses are the 3 pane-type with the following proprieties:

- Solar heat gain coefficient (g): 0.45;
- Solar transmittance (τ): 0.37;
- Visible transmittance (τ_{vis}): 0.67;
- Internal emissivity: 0.837;
- External emissivity: 0.837.

The U-value of the window frame was also changed and set equal to 2 W/m² K.

No other changes have been apported to the general building model.

Figure 48 shows the annual indoor temperature trend when no active and/or passive cooling system is working. Only heating system and ventilation system are in use under the working conditions explained in chapter 3. For this case, named M_H, the operative temperature is always over 26°C, between May and September, reaching during summer period temperature up to 33°C. At first sight, this new structure temperature profile appears really different from the previous one (see Figure 25). The temperature starts rising over 26°C at the end of May and it won't go down, keeps

growing during the all summer period. Thermal comfort analysis (Figure 49) confirms that with only 11% in category II during the summer period acceptable indoor thermal comfort are not guaranteed

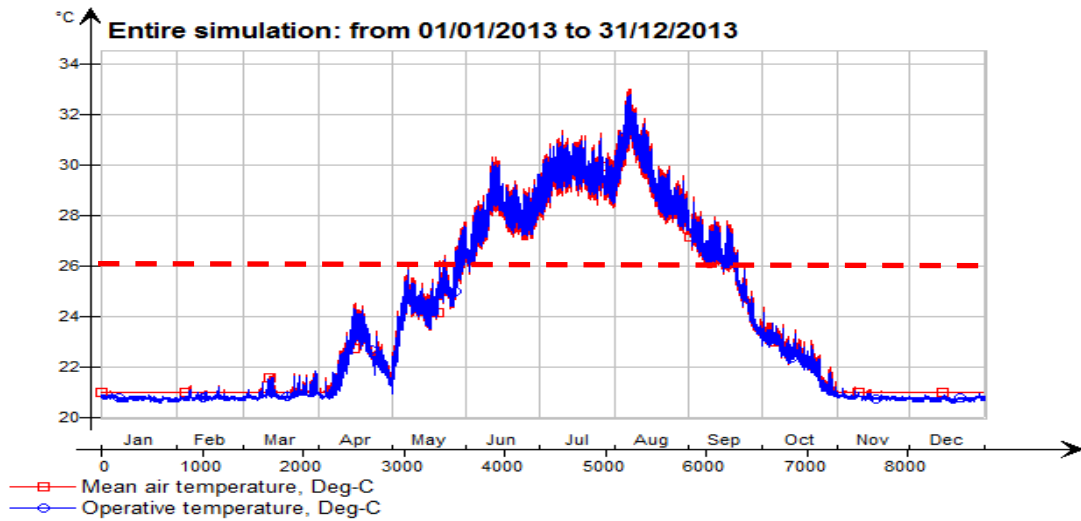

Figure 48 Annual temperature profiles when neither cooling system nor passive strategies are applied (M_H model).

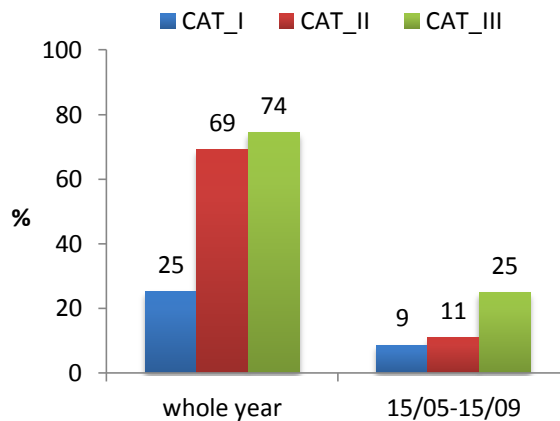

Figure 49 Thermal comfort categories according to EN 15251 for the whole year and for a period between May 15th and September 15th (M_H model)

In Figure 50 the annual temperature trend inside the zone, when the active cooling system is on (M_HC model), are presented. Even if the mean air temperature is stacked on the cooling set point value (26°C), the operative temperature is more or less 0.5 °C higher in all summer time. This means that to keep the operative temperature inside the building zone close to 26°C two ways can be followed. The first one is to decrease the cooling set point at 25°C, or using once again passive strategies. For the purpose of this analysis the second option will be followed, as done in the previous chapter.

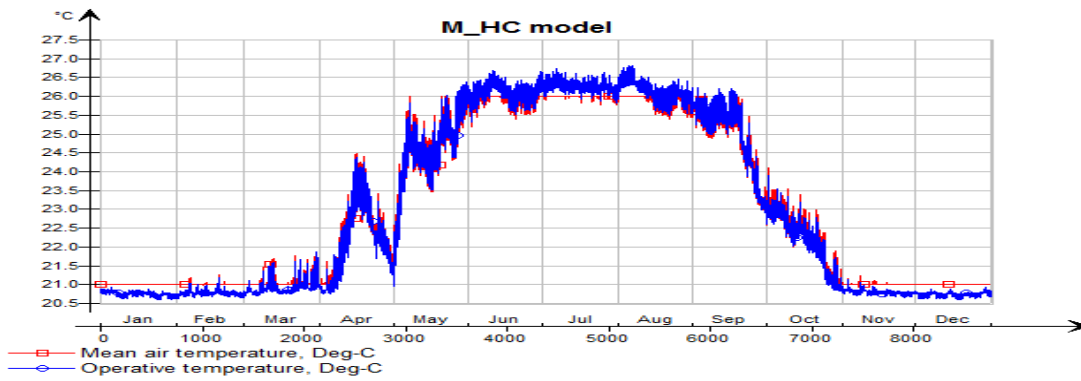

Figure 50 Annual temperature tendency when the active cooling system is working (M_HC model)

In Figure 51 energy demand distribution of M_HC simulation model is shown. Important changes are recorded when compared with the previous structure. By increasing the insulation the heating demand decreases from 59 to 18 kWh/ m² year (69% less) while the cooling demand increases from 13.3 to 21.4 kWh/ m² year (plus 80%). Ventilation and domestic hot water demands are not affected by the building structure changes.

As done for the first building structure, the effect of the passive strategies will be analyzed with regard of energy consumption, thermal comfort and indoor air quality.

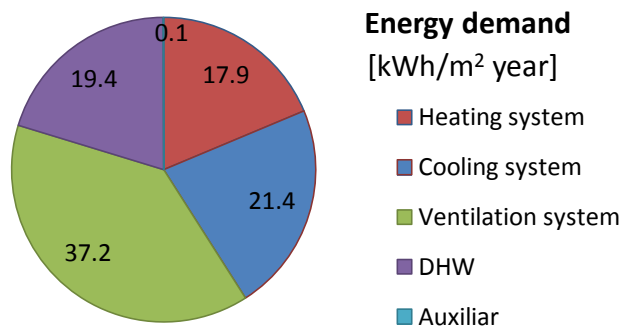

Figure 51 Distribution of energy demand in term of primary energy for M_HC model.

5.1 Results

In this paragraph are collected all the main significant results for the new structure. Even if it has been proved heat recovery ventilation benefits in reaching low energy demand values, the models have been analyzed anyway with and without it. So also for this new structure, six is the total number of case studied.

5.1.1 Energy Demand

Passive strategies seems to be a promising solution to nullify the cooling demand also for better thermal proprieties buildings, as revealed from Figure 52. The percentage reduction varies between 98% (using only *solar shading*) to 100% (using *natural night ventilation* alone or both strategies). This is a great results because this means that cooling system can be completely avoid. The combined use of the two concepts is the best, even though only using natural night ventilation the same result can be obtained.

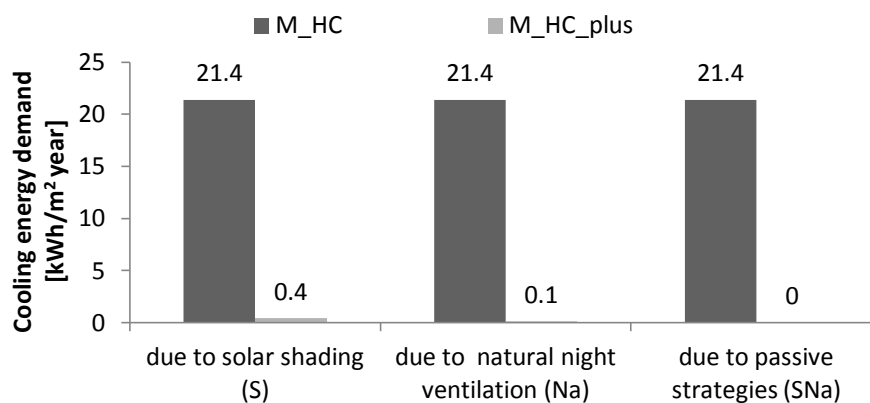

Figure 52 New cooling demand due to the passive strategies compared with the reference model cooling demand

Good performance comes from the use of the heat recovery ventilation. As matter as the fact, looking at Figure 53 and Table 19 the absolute value of energy saved (in term of kWh/m²) is the same if compared with the previous structure (see Table 11); but because of the total lower energy demand the percentage of saved energy goes up to 35% using both passive strategies.

Figure 54 shows the energy demand of each system. What it is important to stress is how, lowering the envelope dissipation by increasing the insulation, the major slice of demand is now covered by the ventilation system and not anymore by the heating one. For this reason the exploitation of the heat recovery ventilation plays an important role in the nearly zero energy building challenge. The analysis concludes that the combined use of heat recovery ventilation and passive strategies brings to an energy saving equal to 51%⁵ in terms of primary energy

⁵ The value comes from the comparison between M_HC and M_HC_SNa_HRV.

Table 19 Total Energy demand of all the case studies with and without heat recovery ventilation

Case studies	Total Energy Demand without HRV [kWh/m ² year]	Total Energy Demand with HRV [kWh/m ² year]	Energy Saving [kWh/m ² year]	Energy Saving %
M_HC	95.9	69.5	26.5	28%
M_HC_S	75.0	48.6	26.4	35%
M_HC_Na	70.5	46.3	24.2	34%
M_HC_SNa	72.4	46.9	25.5	35%

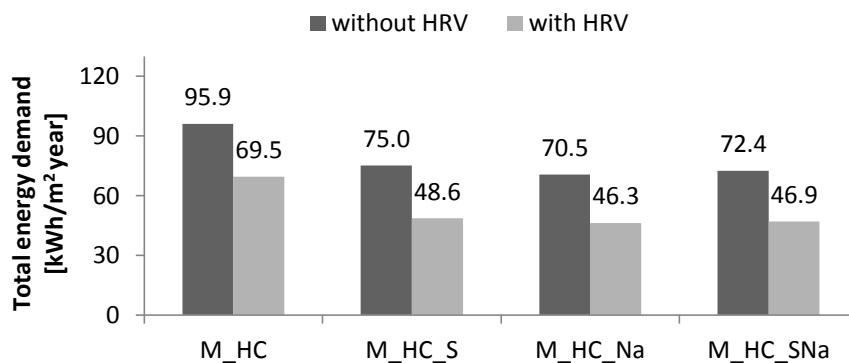

Figure 53 Effect of the HRV on total energy demand for all case studies

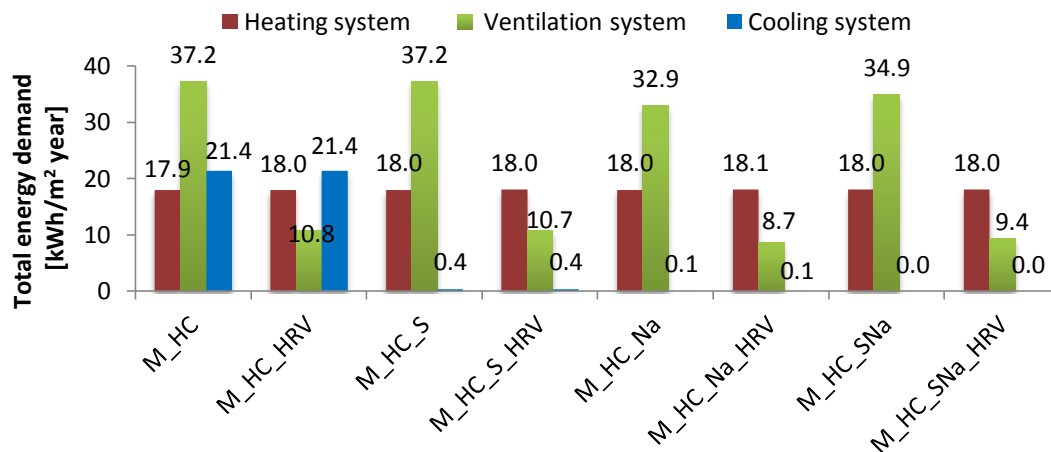
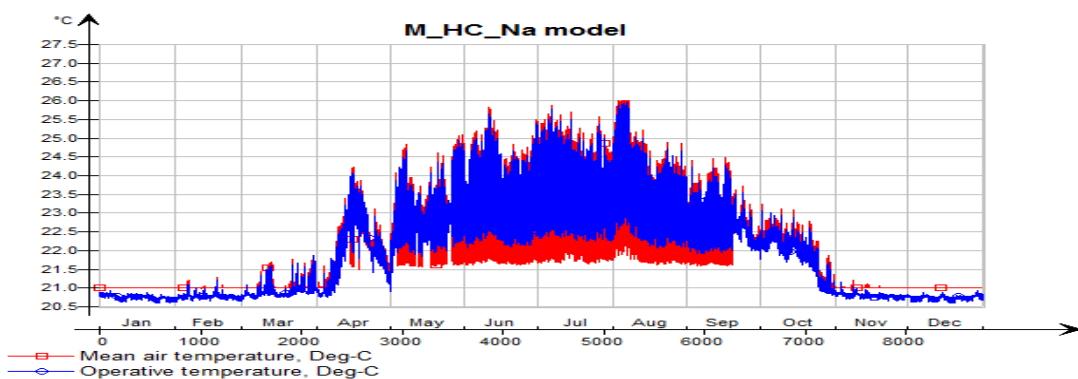
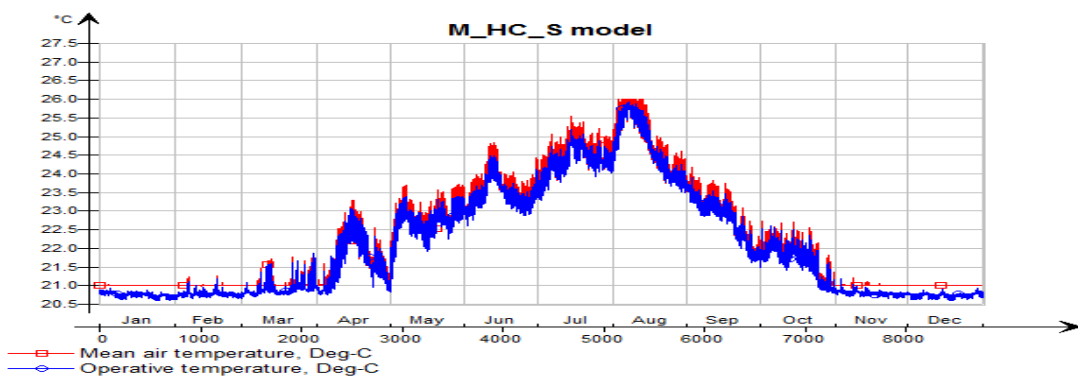
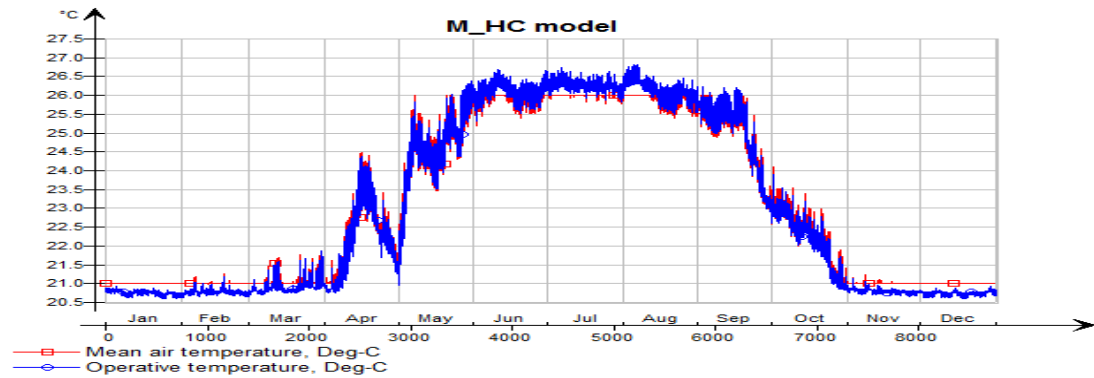

Figure 54 Distribution of the total energy demand between the three systems

5.1.2 Thermal Comfort

Figure 55 collects the annual trends for all the case studies. At first sight they deeply defer to each other. In M_HC model the absence of the solar shading result in a 1-

1.5°C difference temperature between the operative and the mean air temperature. In June, July and August, because of solar gain and the higher insulation of the new structure, the operative temperature is always between 25.5°C and 26.5°C during day and night. This means that people inside the building zone will experience an average temperature of 26°C; even if this is the limit temperature for thermal comfort category II, it seems to create not ideal indoor climate above all in that period of summer in which the outside temperature is in average 8°C lower than the inside.(see APPENDIX B)



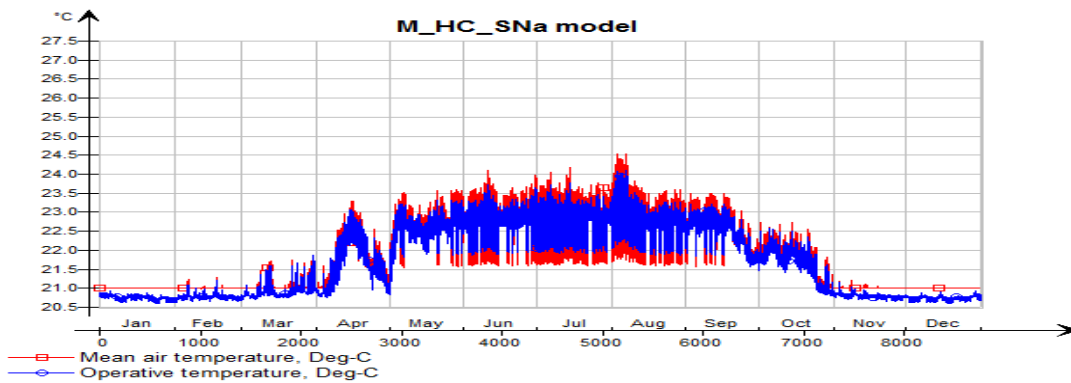

Figure 55 Annual temperature trends for the case studies M_HC, M_HC_S, M_HC_Na and M_HC_SNa

Solar shading implementation seems to solve this drawback, even if the difference temperature is still present, with 0.5°C average values, in the period between May and September. When only natural night ventilation is working the mean air temperature and as a consequence the operative one, is lowered by night. This effect is clearly visible in the monthly temperature profile collected in APPENDIX B. The use of both passive strategies is still confirmed the best solution. The operative temperature is always under the 24°C threshold. The natural ventilation makes feasible the temperature drop during night and the higher insulation combined with the solar shading keeps a low indoor temperature during the day. Nevertheless because the maximum temperature (24°C) reached during summer is 1.5°C smaller than thermal comfort category I threshold (25.5 °C([45])), probably the nighttime windows opening can be reduced only to some windows, for example roof pivoting types.

The operative temperature trends of the M_HC_S, M_HC_Na and M_HC_SNa strongly differ to each other (Figure 56). The warmest two weeks of the summer period (Figure 57) are characterized by curves' divergence around 2°C

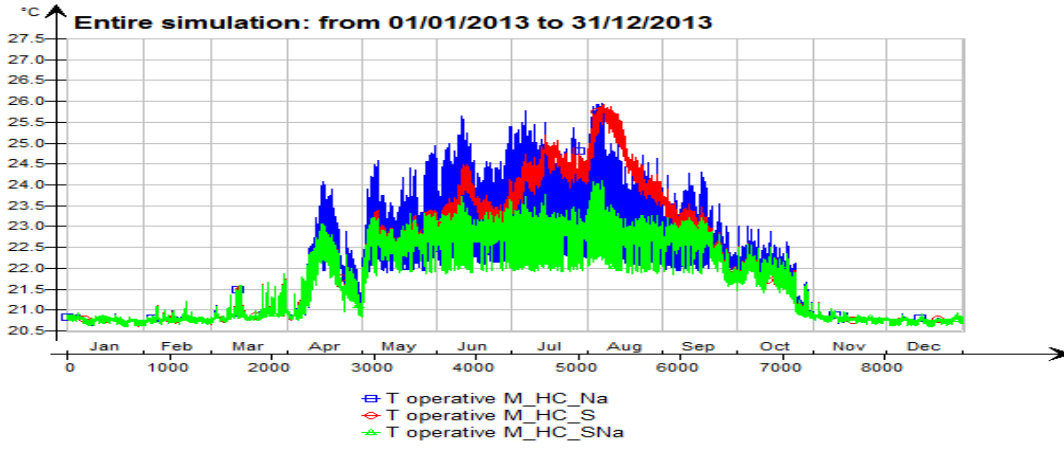

Figure 56 Annual operative temperatures trends

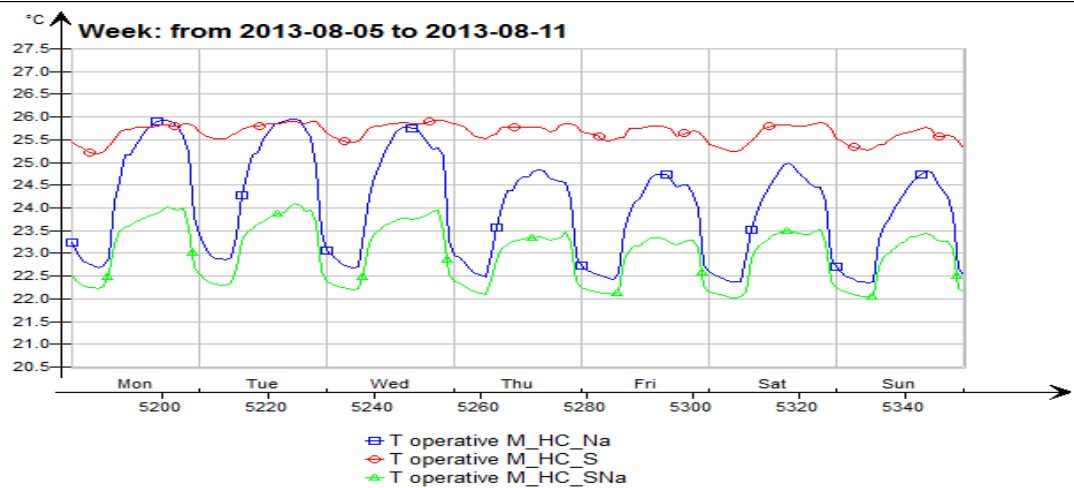
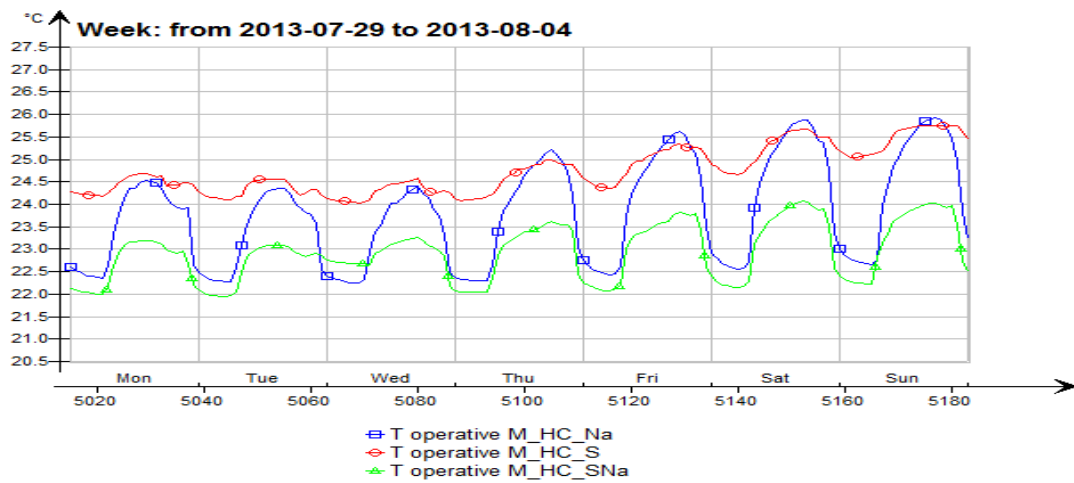

Figure 57 Operative temperature trends during the two warmest week of the year (from July 29th to August 11th)

Thermal comfort analysis (Figure 58) confirms in a quantitative way what just stated. The 28% percentage in category I with M_HC goes up to 54-56% by using the passive strategies. M_HC_Na and M_HC_SNa models have the same thermal response (56% in category II and 100% in category II and III) throughout the all year. The percentages slightly differ when night ventilation period is considered (Figure 59 and Table 20).

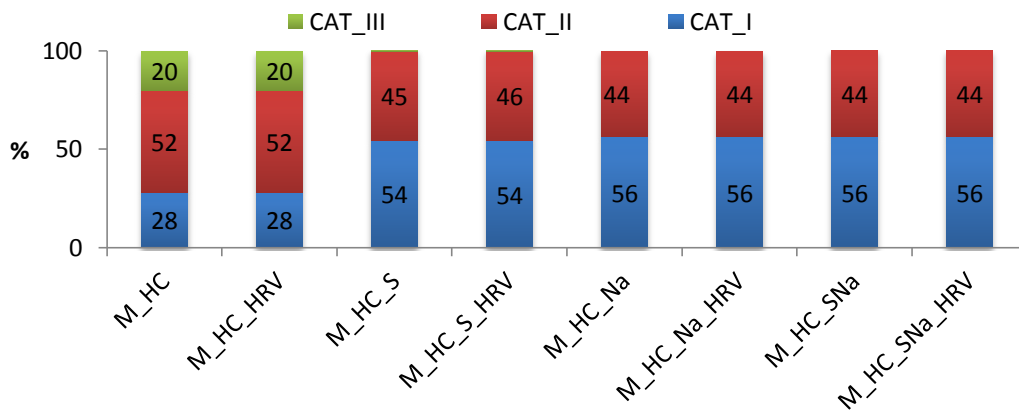

Figure 58 Thermal comfort throughout the year evaluated according to EN 15251 non-adaptive model

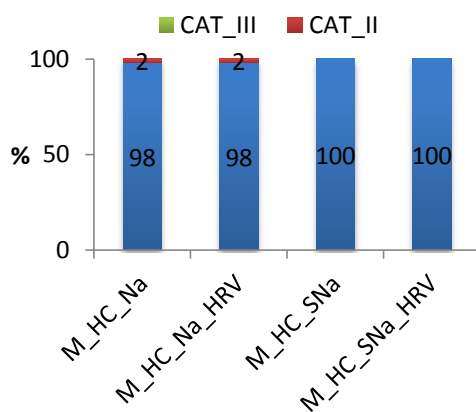

Table 20 Thermal performance during the night ventilation period according to EN 15251 non-adaptive model

Case studies	CAT_I [%]	CAT_II [%]	CAT_III [%]
M_HC_Na	98	100	100
M_HC_Na_HRV	98	100	100
M_HC_SNa	100	100	100
M_HC_SNa_HRV	100	100	100

Figure 59 Thermal performance during the night ventilation period according to EN 15251 non-adaptive model

As for the less insulated envelope, the night ventilation period is different for the two case studies:

- For M_HC_Na from April 14th to September 19th, 156 days over 365 (43% of the time);
- For M_HC_SNa from May 5th to September 16th, 134 days over 365 (37% of the year).

The 100% in category II guaranteed only with the adoption of the natural night ventilation (M_HC_Na) is enough performing to make it chosen as possible solution. However, considering the constant outside temperature grown due to climate changes, to choose a solution will guarantee adequate indoor thermal environment is probably recommended. The operative temperatures are measured in the centre of the building zone. By this point of view the solar shading presence is necessary because

the temperature experience by an occupant close to the windows will be certainly higher than 26°C. So even if the external awnings are not essential under global thermal comfort (Figure 58), it is advisable to use it. Figure 60 show for the same summer day (August 2th) some windows surface temperatures for M_HC_Na and M_HC_SNa models. The number of the windows refers to Table 6 and Figure 18; for each orientation two windows have been taken as representatives. Referring to the orientation:

- SUD-WEST: window 11 and 3(blue lines);
- NORD-EAST: window 14 and 7(brown lines);
- SUD-EAST: window 17 and 20(red lines);
- NORD-WEST: window 18 and 23(green lines).

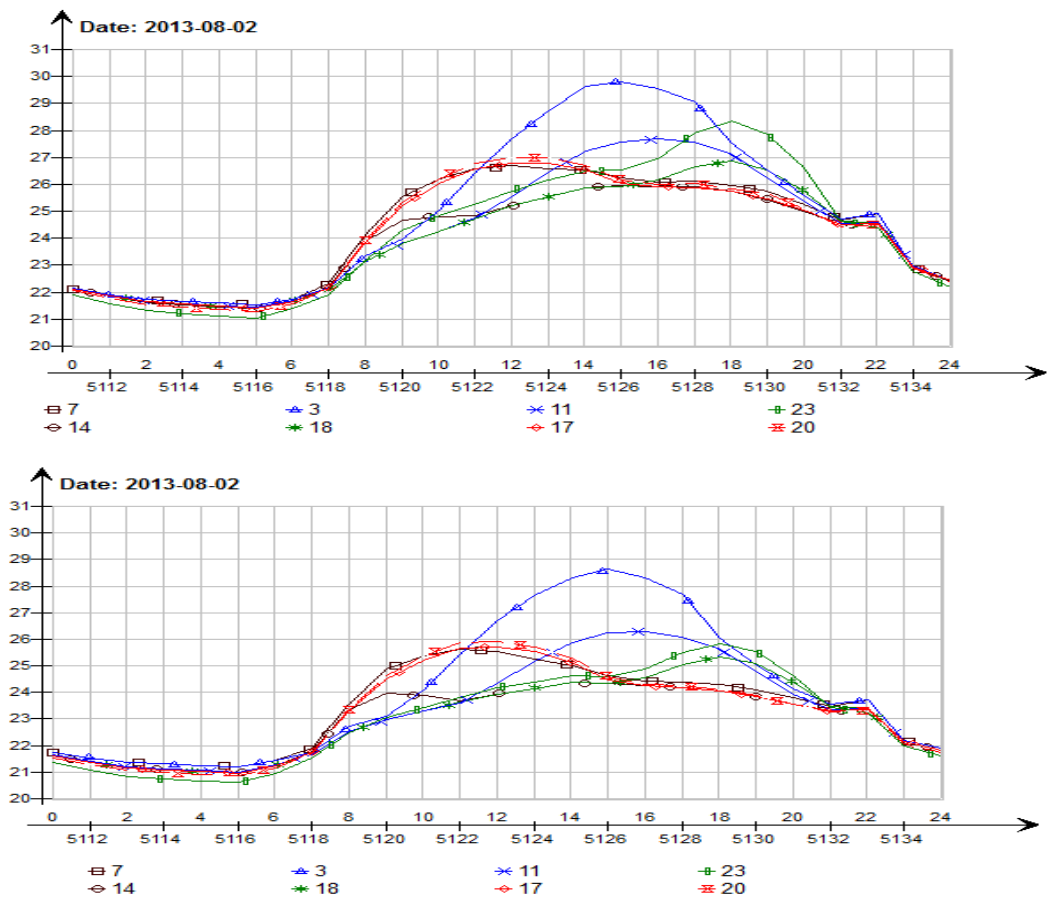

Figure 60 Windows surface temperatures during the warmest summer days M_HC_Na (upper) and M_HC_SNa (lower)

In both the models window 3 (pivoting roof window SUD-WEST orientation) reaches the higher temperature between 1 p.m. and 6 p.m. While in M_HC_Na the maximum temperature is 30°C, by using solar shading (M_HC_SNa) it is lowered by 1°C. A difference surface temperature of more than 2°C for window 23 (NORD-WEST orientation) is recorded. By using solar shading it goes from 28.3°C to

26°C. Considering that at 6 p.m. people are at home, the last result is important revealing that they can surely experience these high temperatures when close to these window. During night the temperatures are quite the same although at 10 p.m. M_HC_Na records average temperatures of 25°C while for the same temperatures are 1°C lower. Generally by exploiting external curtains, the surfaces difference temperatures vary in the range of 1-2°C depending on windows orientation. The results prove that although general thermal comfort is good with both the models M_HC_SNa avoids high windows surfaces temperatures, allowing a more uniform indoor thermal environment.

Table 21 and Figure 61 report the overheating analysis results. Increasing the insulation, overheating hours high values were almost expected. For 19% of the year M_H operative temperature is above 28°C. This is apparently not admissible. M_HC_SNa model is the only one maintaining an operative temperature below 25°C from April to September, as also confirmed by Figure 55. The risk of overheating is basically not present. When only the active cooling system is used (M_HC) the operative temperature will be above 26°C for 19% of time occupancy. This results in thermal comfort category II always below 100%, as proved by Figure 58.

Table 21 Number of hours in which the operative temperature is over the different threshold during the occupancy time

Case studies	To>25°C [h]	To>26°C [h]	To>27°C [h]	To>28°C [h]
M_H	2125	1959	1596	1235
M_HC	2077	1248	0	0
M_HC_S	221	0	0	0
M_HC_Na	109	0	0	0
M_HC_SNa	0	0	0	0

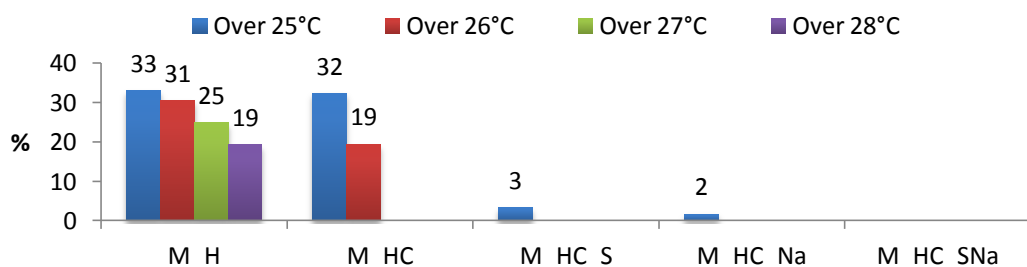

Figure 61 Percentage of hours in which the temperature is over the different threshold during the occupancy time

5.1.3 Indoor Air Quality

The IAQ is always 100% in category I for all the models, with and without heat recovery. Being the conditions excellent for all the case studies it seems unnecessary to show the results histogram.

Table 22 Air change per hour divided between daytime and nighttime during the night ventilation period

Case studies	ACH Night [vol/h]	ACH Day [vol/h]
M_HC	0.6	0.5
M_HC_HRV	0.6	0.5
M_HC_S	0.6	0.5
M_HC_S_HRV	0.6	0.5
M_HC_Na	3.4	0.5
M_HC_Na_HRV	3.4	0.5
M_HC_SNa	2.0	0.5
M_HC_SNa_HRV	2.0	0.5

Figure 62 and Table 22 show the air changes per hour values during the period between April 14th and September 19th (natural night ventilation period for the M_HC_Na took as reference for the analysis). The natural ventilation is more exploited because of the increased ACH values. Being the structure more insulated, 23°C of indoor temperature (threshold for night ventilation activation) are achieved earlier making necessary higher ACH values to keep the thermal comfort in good range. Nevertheless, by using solar shading the ACH during night goes from 4.5 (M_HC_Na) to 2.0.

As in the other results analysis the heat recovery has no negative or positive effect on the indoor air quality.

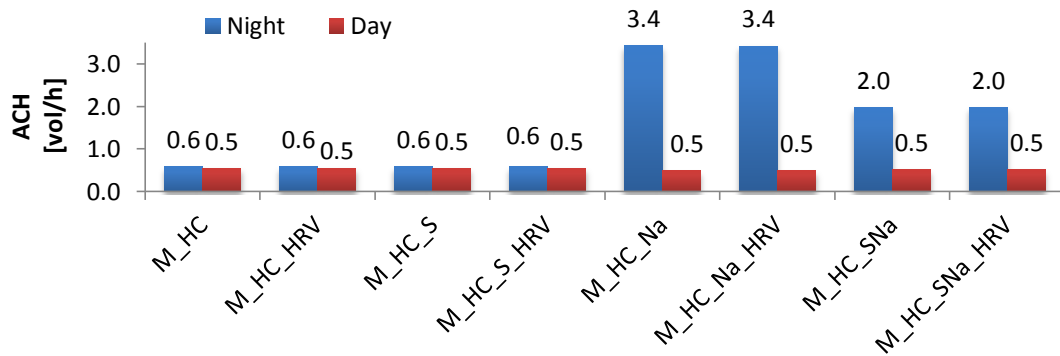

Figure 62 Air change per hour divided between daytime and nighttime during the *night ventilation period*

5.2 Effect of behavior ventilation

The effect of the behavior ventilation was also analyzed for the new structure.

No changes has been recorded for the energy demand, the value is still around 47 kWh/m². The same for the indoor air quality (always 100% in category I) and for the thermal comfort during all the year. Figure 63, 64, 65 and Table 23 show the results. What is changed is the application period. It now goes from April 9th to October 21th.

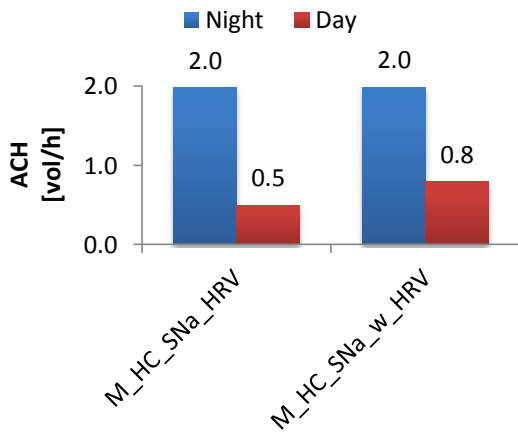

Table 23 Air change per hour divided between daytime and nighttime during the *night ventilation period*

Case studies	ACH Night [vol/h]	ACH Day [vol/h]
M_HC_SNa_HRV	2.0	0.5
M_HC_SNa_w_HRV	2.0	0.8

Figure 63 Air change per hour divided between daytime and nighttime during the *night ventilation period*

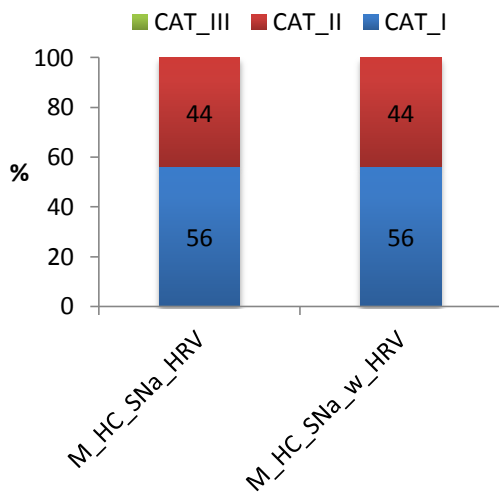

Figure 64 Thermal Comfort among the year evaluated according to EN 15251

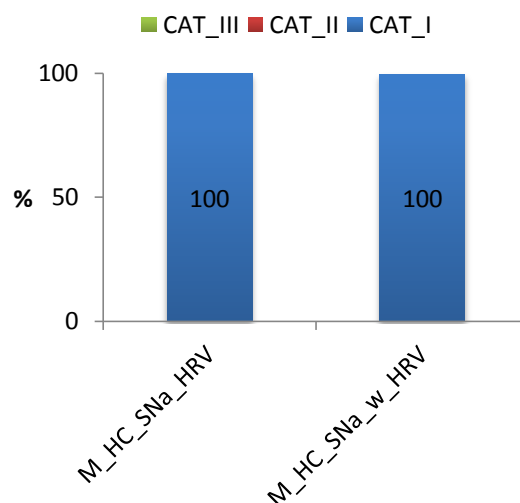

Figure 65 IAQ among the year evaluated according to En 15251

6. RESULTS COMPARISON of TWO BUILDING STRUCTURES

In this chapter the simulated results obtained by applying the model on two different building insulation's structures are compared. Data referred to the building characteristics presented in chapter 3 are called structure A, while structure B are the results obtained for the building presented in chapter 5. The average transmittance values are listed in Table 24.

Table 24 Building models transmittance values

Building models	Average U-value for opaque surfaces [W/m ² K]	Average U-value for glazed surfaces [W/m ² K]
STRUCTURE A	0.30	1.127
STRUCTURE B	0.18	0.583

6.1 Energy Demand

The energy demand variation plus the energy saved moving from STRUCTURE A to B are shown in Table 25 and Figure 66. Fluctuations in the energy demand are recorded for both structures. A goes from the maximum value of 127 kWh/m² year (M_HC) to the minimum of 89 kWh/m² year (M_HC_SNa_HRV). For B the values are lower going from 96 kWh/m² to 47 kWh/m² year, still with the same models.

The combination of solar shading, natural night ventilation and heat recovery gets the energy demand best solution, for both structures. For the model equipped with HRV, the energy saved, by passing from A to B, is 10% higher.

Table 25 Comparison in term of total energy demand

Case studies	STRUCTURE A [kWh/m ² year]	STRUCTURE B [kWh/m ² year]	Energy Saving %
M_HC	127	95.9	24
M_HC_HRV	101	69.5	31
M_HC_S	116.4	75	36
M_HC_S_HRV	90	48.6	46
M_HC_Na	118.7	70.5	41
M_HC_Na_HRV	93.8	46.3	51
M_HC_SNa	115.1	72.4	37
M_HC_SNa_HRV	89	46.9	47

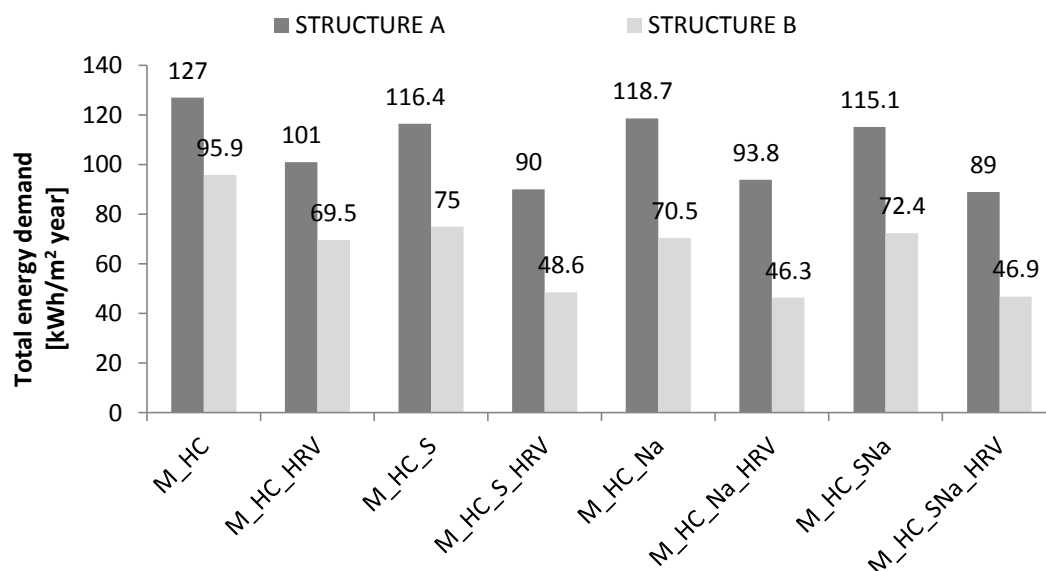

Figure 66 Total energy demand histogram for all the models separated for the two structures

By exploiting different solutions, the energy demand allocation of the three systems (heating, cooling and ventilation) is changed. Through pie charts (Figure 67) this different allocation is shown for M_HC and M_HC_SNa_HRV, the extreme energy demand case studies.

The building with higher insulation increased by 61% on cooling demand proportionally with 69% decreasing of heating need.

When the heat recovery ventilation is ON a ventilation demand reduction of 73% is achievable. By exploiting both passive strategies the cooling demand is reduced or nullified (no more a blue slice in the total energy demand).

The complete comparison in term of energy demand for all the models and for both structure is collected in APPENDIX C.

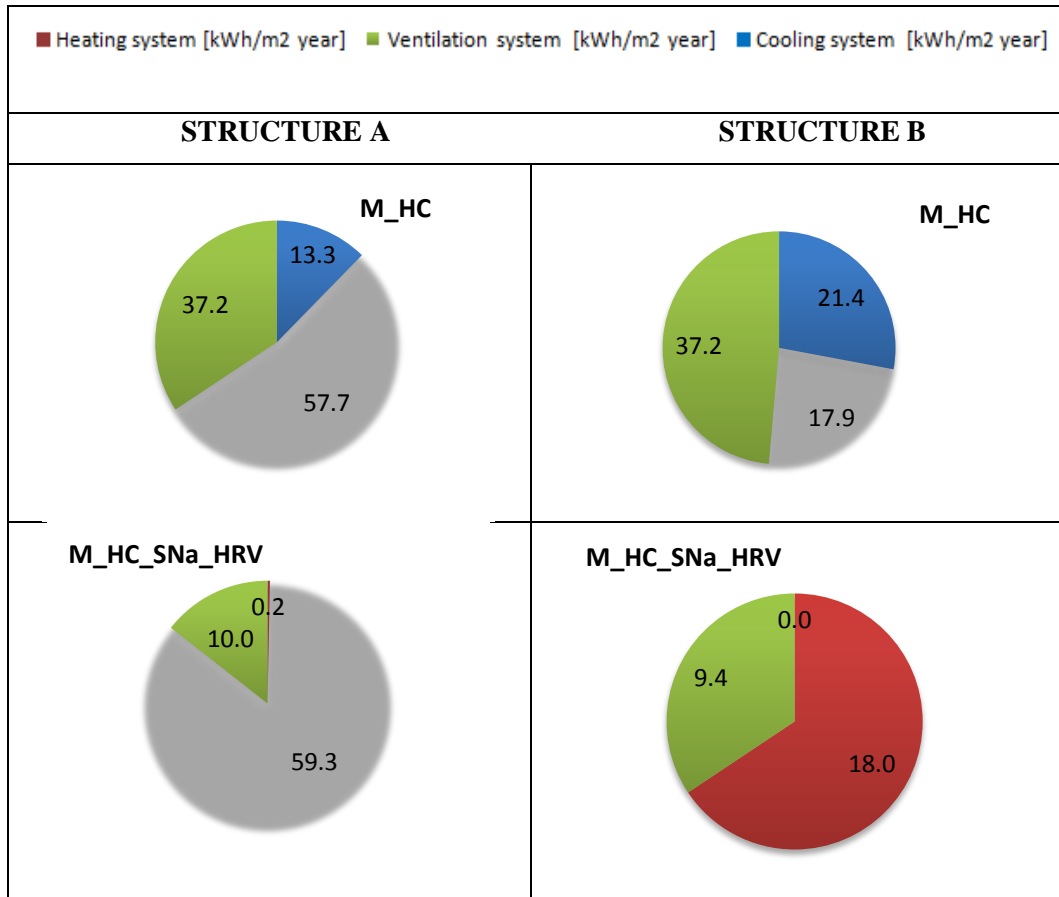

Figure 67 Energy demand divided by the three systems for M_HC_HRV and M_HC_SNa_HRV models for both structure A and B.

6.2 Thermal comfort

Because of the large number of case studies (eight per structure) it has been chosen to compare the models separately per thermal comfort category. Figure 68 collects three histograms, each one corresponding to category [45]. Thermal comfort category I is the more affected by changes moving toward the two structures. STRUCTURE A behaves in a better way than STRUCTURE B only for M_HC model. Because of the restrained thermal losses of B when an indoor temperature is reached this will be kept for a long time. For all the other models STRUCTURE B behaves better increasing the percentage by 18-20% depending on the case study. M_HC_SNa model is the only one which vouches for best thermal comfort in category II (100%) for both structures.

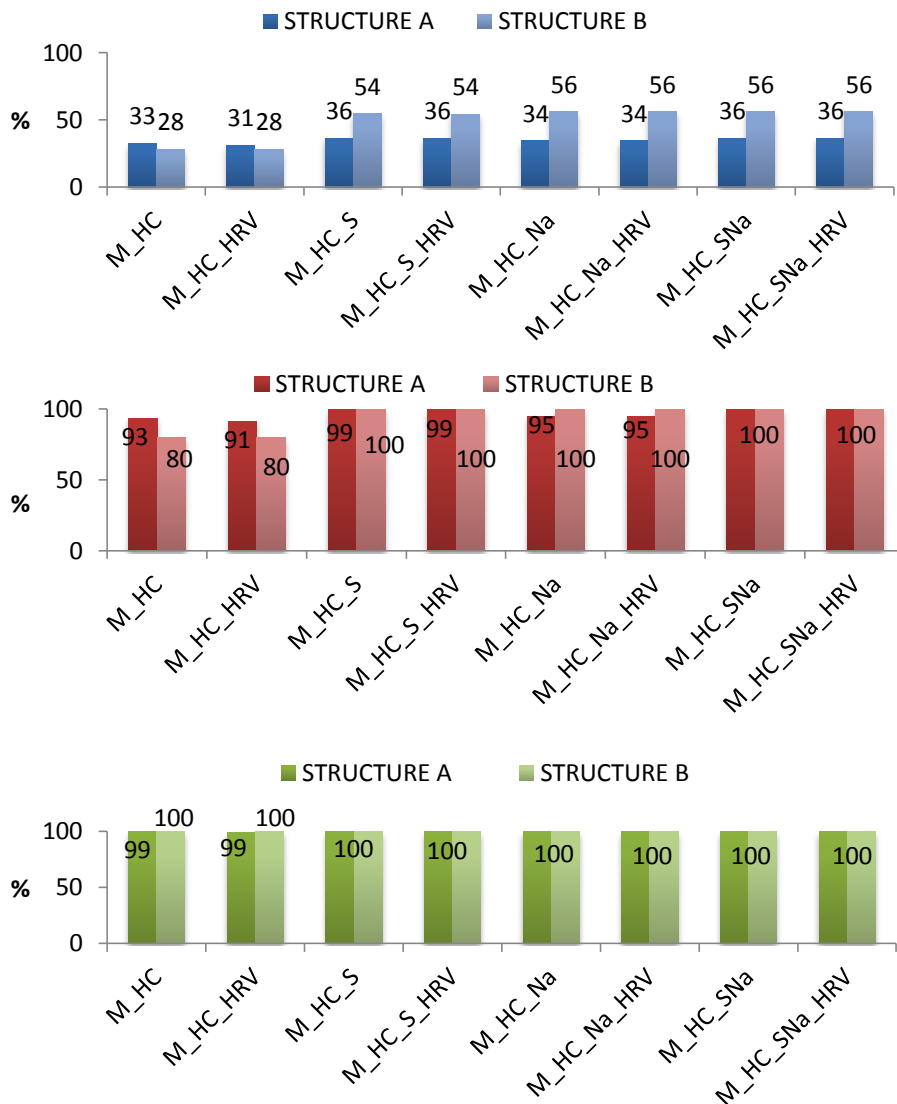

Figure 68 Whole year thermal comfort evaluated with EN 15251 non-adaptive model divided per category (category I-upper; category II-middle; category III-lower)

The results of Figure 69 refer to the night ventilation period. The percentages in category I are higher and STRUCTURE B behaves in better way. Combination of well-insulated structure with passive strategies leads to the best thermal condition (100% in category I) according to the European standard EN 15251.

Figure 70 shows the annual temperatures tendencies of M_HC and M_HC_SNa_HRV underlining differences between the two structures. Looking at M_HC graph (upper) a deep divergence is clearly visible among the structures. For STRUCTURE A (blue line) the temperatures fluctuate in a wide range while for STRUCTURE B (red line) the profile is quite flat. When passive strategies are applied, they strongly affect the temperatures. The maximum temperatures are lowered by 1.5-2.5°C

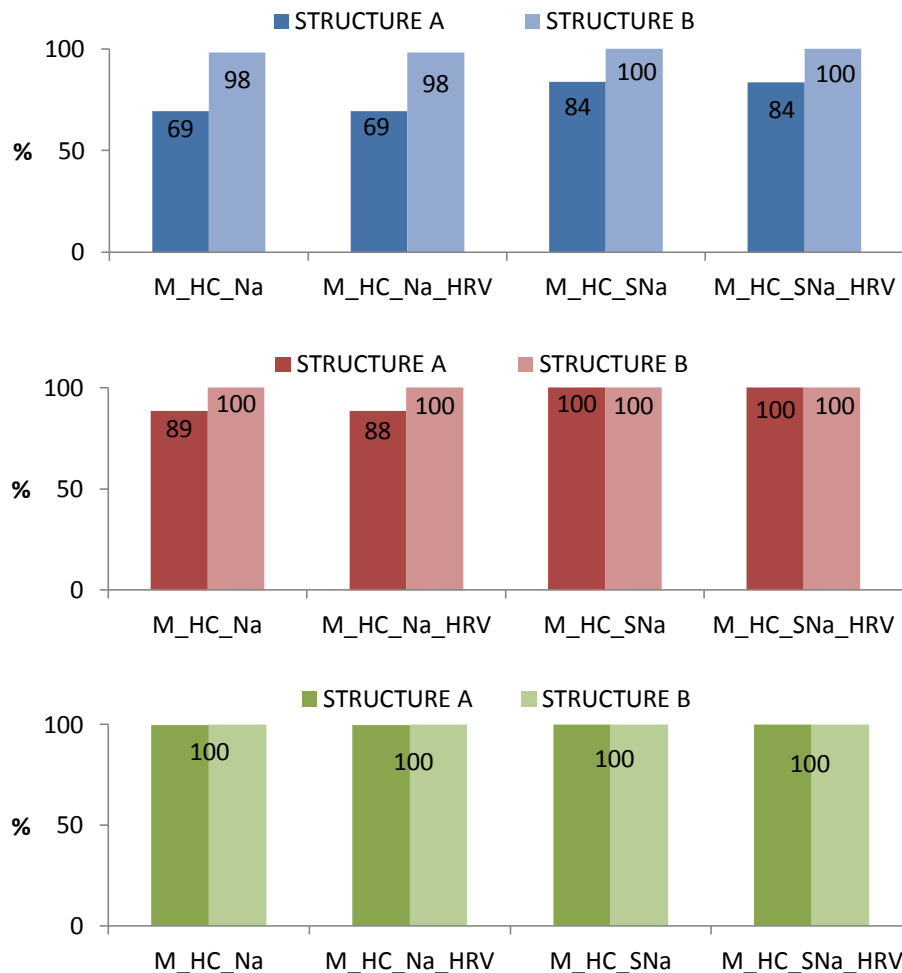

Figure 69 Night ventilation period thermal comfort evaluated with EN 15251 non-adaptive model divided per category (category I-upper; category II-middle; category II-lower)

Taking as example a warm summer day (August 1th) a significant day-night temperature ranges difference are observed among the two structure.(Figure 71).While STRUCTURE A range is around 3.5° (M_HC) and 4.5 °C (M_HC_SNa_HRV) for STRUCTURE B it is smaller: 0.5 °C (M_HC) and 1.5 °C (M_HC_SNa_HRV).

This is an additional confirmation of how STRUCTURE B’s envelope make possible a less floating operative temperature The same characteristic is also the main cause of overheating problems. When during night the indoor temperature is quite high it keeps such value (and even more) also during day (M_HC) resulting, most of the time, in overheating problems. The solution is the adoption of the passive strategies. By lowering the indoor temperature during night, because of the structure, it will kept low, unless the natural increase due to solar radiation, during all the day.

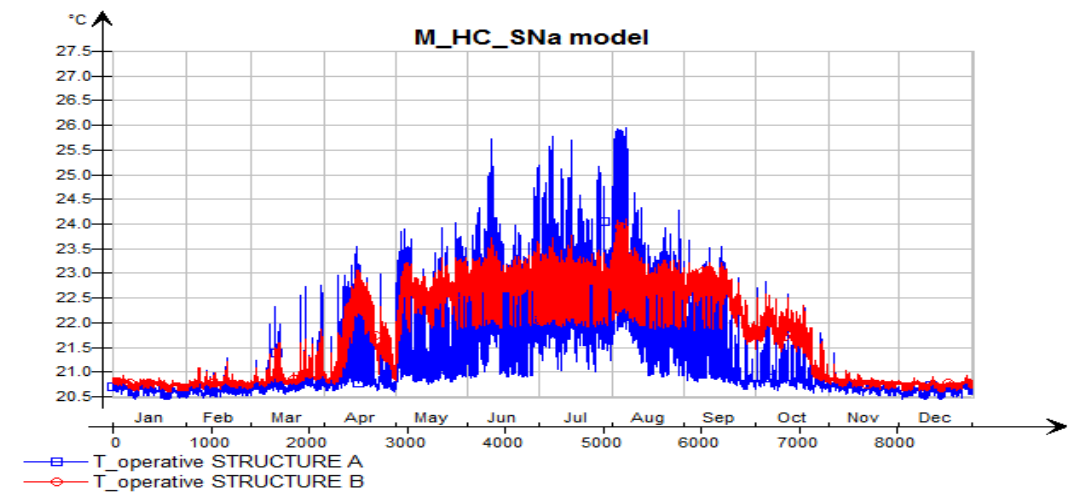
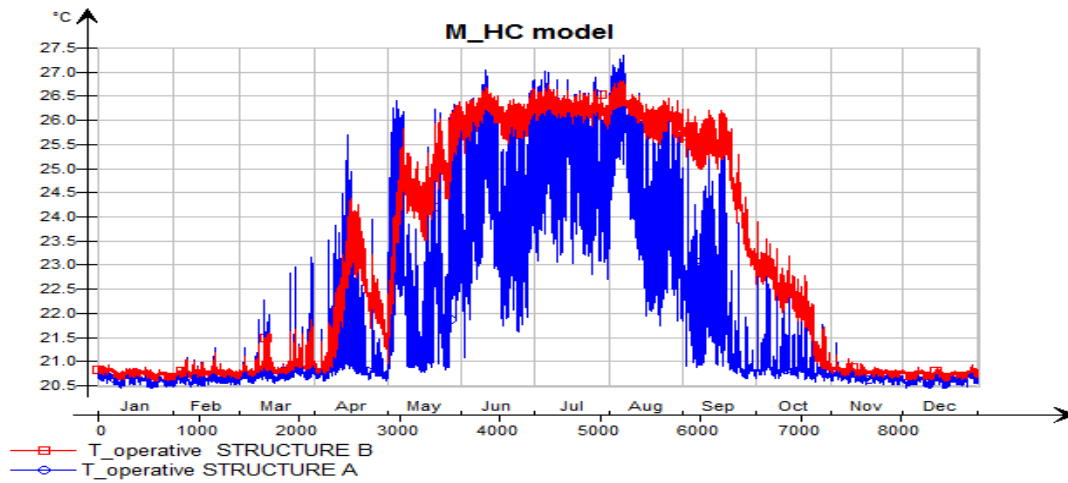

Figure 70 Annual operative temperatures trends for the two structures. M_HC model (upper) and M_HC_SNa_HRV (lower)

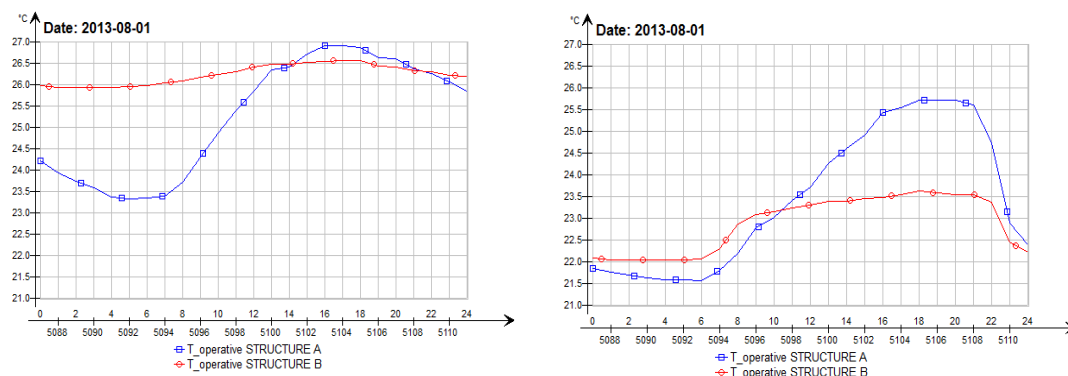

Figure 71 Comparison of operative temperatures trends for both structures and for the extremes case studies: M_HC (left) and M_HC_SNa_HRV(right)

Figure 72 collects the compared results for what concern overheating. Bearing in mind well-insulated STRUCTURE B behavior, it is very easy to understand why for that structure, the number of hours in which the temperature is above certain thresh-

old, is always bigger than for STRUCTURE A. The range varies between 3 and 5 times more depending on the threshold considered. This happens only for the models missing of passive strategies (M_H and M_HC). When they are exploited the situation is overturned for 25°C threshold and completely solved for the others threshold.

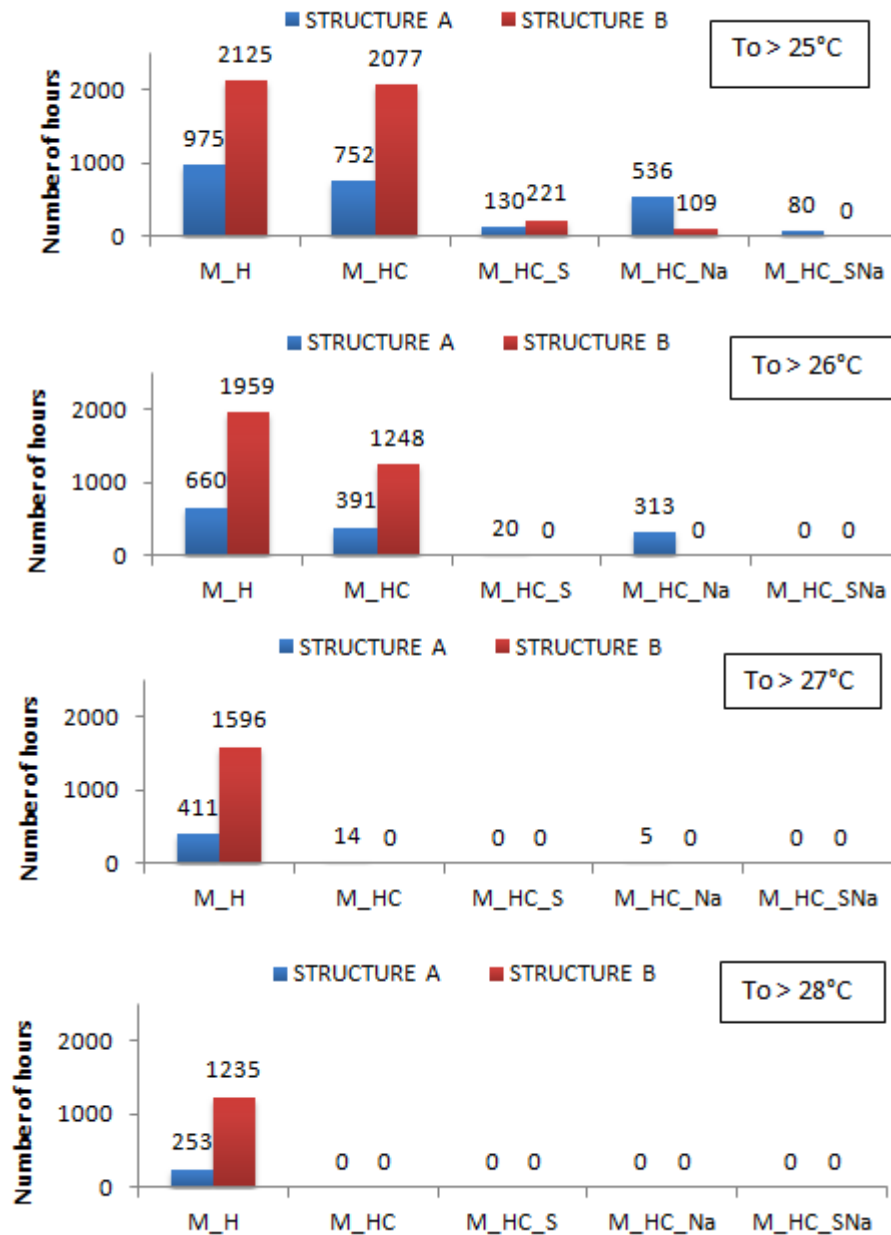

Figure 72 Comparison between the two structures in term of overheating hours divided for different thresholds (25°C, 26°C, 27°C and 28° C).

6.3 Indoor Air Quality

The indoor air quality is more or less always excellent for both the structures that it seems to be superfluous to show again the comparative results. The only aspect that worth to be underlined has shown in Figure 73.

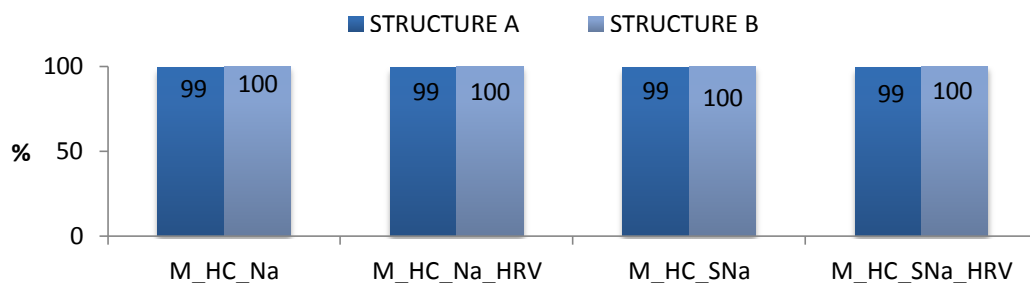

Figure 73 Comparison of IAQ category I during *night ventilation period*

During night ventilation period all the models of STRUCTURE B make a 100% category I indoor air quality while for STRUCTURE A is slightly less (99%).

Clearly STRUCTURE B makes more use of the natural night ventilation. Considering M_HC_Na model, STRUCTURE B asks for an ACH 2.6 times bigger than that one needed by STRUCTURE A. This value decreases to 1.5 times when both passive strategies are used (Figure 74).

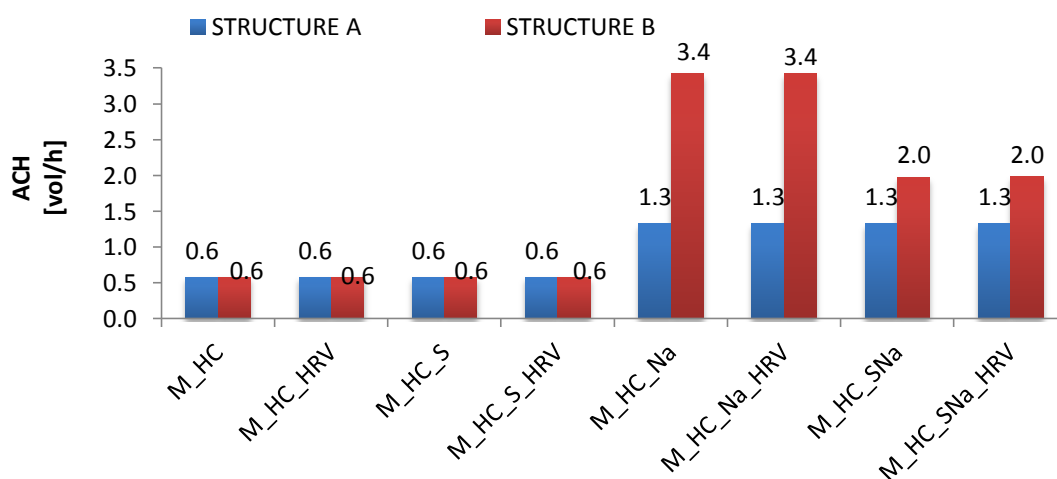

Figure 74 Comparison between the two structure in term of Nighttime Air change per hour during night ventilation period

6.4 Effect of Behavior ventilation

Changes in the structure have not influence the daytime ACH (0.8 ach⁶). Nevertheless, the opening frequency of the windows interested is deeply difference between the two structures. First of all, as shown in Figure 75, windows 13, 14 and 15 (NORD-EAST orientation) open for more or less double time of windows 9, 10, 11 and 12. STRUCTURE B's windows open more often than those one of STRUCTURE A. The ratio is more or less 2 for both types of windows.

Table 26 shows the average flows and opening width for both structures. Windows belonging to a certain type open in the same way. The value of average flow and opening width are, indeed, exactly equal.

STRUCTURE A have a double, or even more, values of STRUCTURE B. Nevertheless B the opening of the windows is more often, actually is the double. Because of this compensation the daytime ACH is equal.

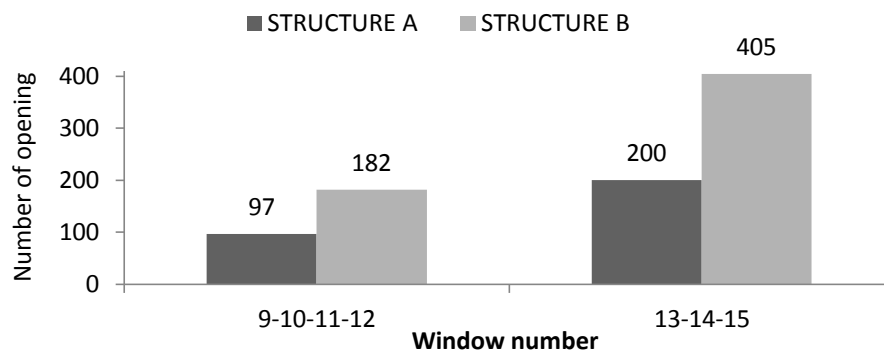

Figure 75 Comparison about the numbers of openings

Table 26 Average flow and opening width

Windows	Average Flow STRUCTURE A [l/s]	Average Flow STRUCTURE B [l/s]	Average Open- ing width STRUCTURE A [cm]	Average Open- ing width STRUCTURE B [cm]
9	34.3	15.7	9.8	4.6
10	34.3	15.7	9.8	4.6
11	34.3	15.7	9.8	4.6
12	34.3	15.7	9.8	4.6
13	64.1	26.8	8.5	3.7
14	64.1	26.8	8.5	3.7
15	64.1	26.8	8.5	3.7

⁶ During daytime for model M_HC_SNa_w_HRV considered for both structure.

7. NIGHT VENTILATION: A COMPARISON BETWEEN MECHANICAL AND NATURAL

In this chapter natural night ventilation will be compared with mechanical night ventilation in term of indoor thermal environment and energy demand. The reason comes from the awareness that, even natural night ventilation advantages it has several drawbacks. The unpleasant problem to open and close the operable windows at appropriate time according to building needs seems to be overcome by installing automatic control. Sure enough, if people don't open and close the windows at the correct hour, then their building might be uncomfortably hot the next day. The way to make this problem less of an occupant control issue is to use an automatic device as for Velux's windows. First human error is avoided and second fresh air to cool down the structure is flushed inside when needed in accordance with the temperature swing. Nevertheless there are other concerns with air quality, security and noise.

The opening of the windows may introduce pollen, dirt, dust and toxins especially in those big metropolitan areas where pollution is a serious health problem. As earlier showed, indoor air quality of all the analyzed models is pretty high. For the climatic condition of Copenhagen a reference value of 350-400 ppm of outside CO₂ concentration has been taken, which it can be higher in cities with much more stressed pollutant level. Major attention needs to be focused on the other two backward: security and noise, especially for a residential building.

Leaving windows opened all the night could be a serious risk for inhabitant's safety especially when, for efficient ventilation, the windows at the lower floor level of the building should be open, attracting unfortunately theft, trespassing and vandalism.

The last issue is related to noise, which come from outside and/or from the increased air flow through the windows opening and /or mechanical ventilation ducts. Especially during night when the building is occupied, exterior traffic noise and other outdoor sounds can be a distraction for the sleeping and resting.

Copenhagen climate in summer is often characterized by a rainy period, inconvenient that should not be underestimated. If the building has shading devices over the windows they could assist in blocking rainfall from entering the building, implementation that should be considered in the windows automatic control. How many and how much the windows are kept open by the control during the night was here calculated. In particular, the opening width was estimated resulting useful to evaluate the weight of the mentioned drawbacks.

Taking into consideration those negative aspects, the use of the outside night colder air through the ventilation system, supported by the only fan that move the air from outside to inside. The impact on energy demand and thermal environment was evaluated aiming at the satisfaction of cooling demand.

7.1 Variations of natural night ventilation model

The starting point model will be that one who gave, in the previous analysis, the best performance in term of indoor environment and energy consumption. Therefore M_HC_SNa_HRV model of STRUCTURE B case study will be the starting model not only for the best performance shown but also because in a looking-future way all the new building in Denmark, starting from 2015, shall be constructed with those thermal transmittance characteristics.

Nevertheless, taking into consideration security problems, some changes have been done in the model windows opening configuration during night. While in the preliminary analysis all the typologies of windows were interested in the natural night ventilation, now in this new version model some of the windows are kept out. All the type of windows can be opened during night except for type B and C (see Table 6 and Figure 18).

The maximum opening values are the following:

- For type A1(1-2-3-4-5) and A2(6-7-8) it is 21.4 cm;
- For type D1(16-17) and D2(18-19) it is 28.4 cm;
- For type E1 (20-21) and E2 (22-23) it is 22.3 cm.

This new configuration avoids largest lower floor doors opening but at the same time, keeping opened all other windows, efficient ventilation is guaranteed.

Other changes have been done to improve the building model. Taking a look to the models monthly heating demand of previous study, it has been discover that when both passive strategies are implemented the heating demand during summer period (from June to August) is not nullified, even if it is a very low value (more or less 0.8 kWh/ month).To overcome this inefficiency a new heating system operation schedule is set. According to Copenhagen heating period, it can work only from August 31th to June 6th .By using this schedule the demand is 2.3 kWh/m² year lower (15.7 instead of 18 kWh/m² year). Moreover the heating set point has been increased by 0.5 °C (from 20°C to 20.5°C), to make the indoor operative agree with the standard. In the previous model was discovered that the operative temperature was lower than 20 °C even if the control was set on that value. This happens because all the control work on the air temperature and not on the operative one.

The cooling system was usually set with 26°C set point, even if as demonstrate by applying passive strategies, it will not use at all because indoor thermal environment is kept under this threshold temperature.

7.2 New AHU design: a variable air volume solution

When the opening of the windows during night is not recommended because the drawbacks are dominant and not easily to overcome, different solutions should be considered to cool down the building.

One solution could be the increase of air change rate from the mechanical ventilation. This system would essentially work like the normal air handling unit that brings inside the outside air. The outside air will be first processed (heating coil ⁷ and heat exchanger) and then sent to the supply ducts to be circulated throughout the building, with the supplied air flow not fixed at 0.5 during the night (see paragraph 3.3) increasing according the indoor thermal conditions. The use of *Variable Air Volume* was applied only for the night ventilation system and not for the full performance of HVAC that was continuing to perform as earlier explained in paragraph 3.4.

To create and make reasonable the comparison with *natural night ventilation model*, the controller conditions were kept the same at the ones for opening the windows. Therefore when the temperature inside is higher than 23°C:

- For natural night ventilation model (NNV) the windows will be opened and kept open during all the night modulating through a proportional control the opening width;
- For mechanical night ventilation model (MNV) the supply air flow will be automatically increased satisfying, as possible, building cooling demand.

Moreover, still for an equity matter between the two models, the maximum air flow supplied by the fan during night (MNV model) was fixed to be equal to the maximum air flow value that enters through the windows (2600 l/s). Nevertheless, after a careful design analysis (described in APPENDIX D), considering that actually ducts size has to suite a residential building, a value of 141,3 l/s has been set as maximum value for supplied/returned air flow. This means that, according to the building volume, the maximum air change rate (only due to mechanical inflow) reached during night was 1 ach.

From May 1th till September 30th was the period in which the two different night ventilation strategies were applied. it was not randomly chosen but chosen considering night opening windows period for NNV model and then adapted to MNV model. This means that fan can supplies increased air flow only in that period While for the rest of the year, the ventilation system works only to guarantee the minimum 0.5 ach during occupancy hour.

⁷ Actually the heating coil is used only during winter period when the outside temperature needs to be processed till 16°C before being introduced in the building zone. Therefore during summer period, when the temperature has a higher value, the air is just taken from the outside and supplied.

The aim of those analysis wanted to figure out how the indoor environment and the energy demand can be compromise by using an active strategy (mechanical) instead of a passive one (natural ventilation).

7.3 Results

An increased ventilation system energy demand was expected because of fans grown use during nighttime. In Figure 76 the different system energy demands are showed. When the variable air volume system is used ventilation demand is 18% higher. As consequence the total energy demand is slightly different (Figure 77).

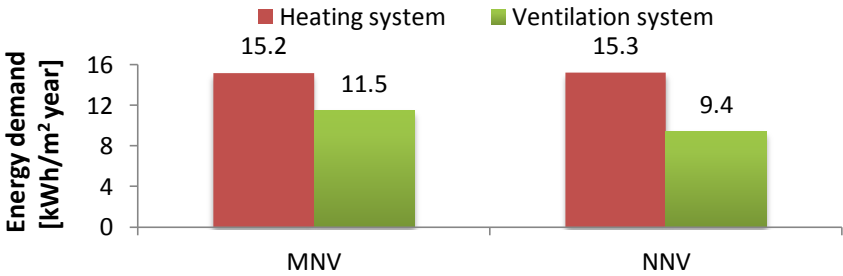

Figure 76 Energy demand systems for MNV (increased ACH) and NNV (windows opening).

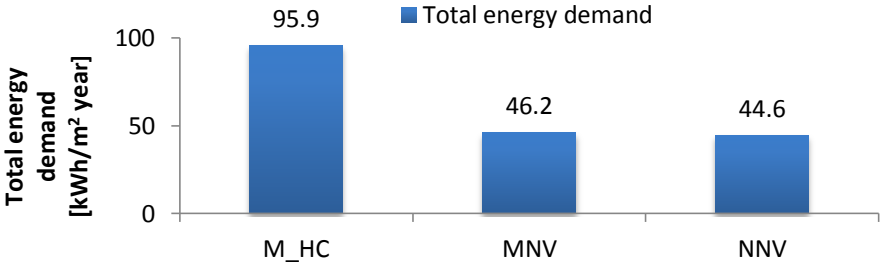

Figure 77 Total Energy demand for the alternative night ventilation strategies and for the reference model

The air change rate analysis was done also for these models. The values (Table 27) refers to the period May 1th-September 30th. Among the hourly value, the maximum, minimum and average values have been identified While the minimum value is the same, the others two values deeply differs to each other, in particular the maximum one is extremely different. For MNV this value is conditioned by ducts size while it is not for NNV. Because the windows area is much larger than the ducts one, the fresh that can be flushed inside is higher. Indeed, the air change rate for NNV model is 15 times bigger than for MNV one.

Figure 78 shows the air change rate tendencies for both solutions for the considered period.

Table 27 Air change rates maximum, minimum and average for the two solutions

vol/h	MNV	NNV
MAX	1.1	18.5
MIN	0.6	0.6
AVERAGE	0.8	1.8

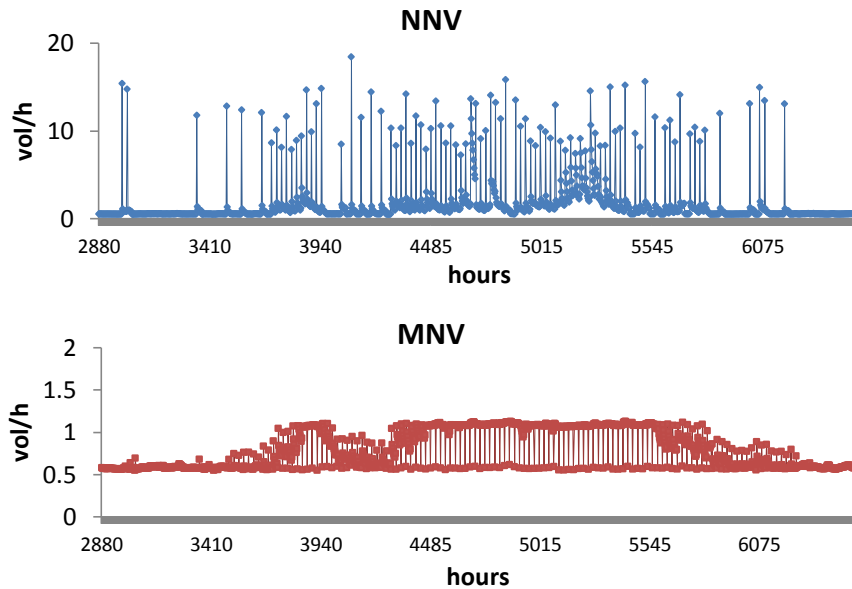

Figure 78 Air changes rate tendencies during the period between May 1th and September 30th

Figure 79 collects the thermal comfort results for the whole year and for May 1th - September 30th period. In both cases, MNV seems to have the best performance. Nevertheless, the two models performances are not so far from each other's.

The different indoor thermal environment generated by the active ventilative strategy (MNV) and the passive one (NNV) is shown in Figure 80. The two operative temperature profiles, during a warmest summer day are represented. Here it is once more highlighted natural night ventilation potential. Indeed, by keeping the windows opened during night, the storey is more cooled down. This affects the daytime operative temperature being more or less 1.5-2 °C lower than MNV. Thermal mass and natural night ventilation, coupled, provide a thermal sink for internal gains during the day. By using the mechanical night ventilation, there is still the “thermal sink” effect but softened Night-day temperature difference of 0.5°C for MNV goes up to 1,5°C for NNV solution. The monthly temperature trends are shown in APPENDIX E plus a compared temperature trends during the warmest week.

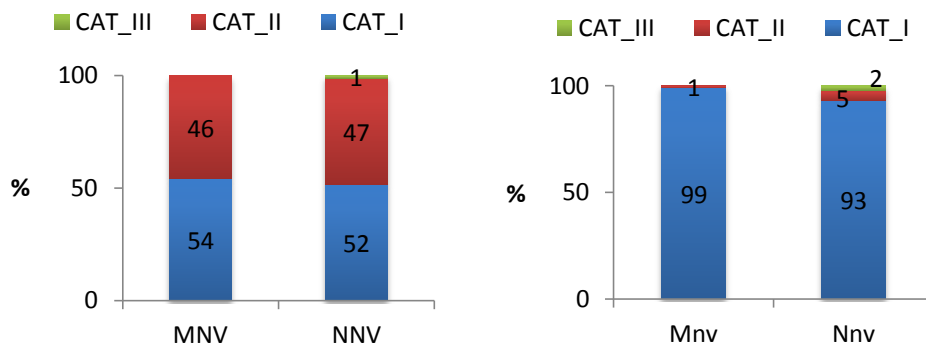

Figure 79 Thermal comfort categories according to EN 15251 for the whole year (left) and for the night ventilation period (right).

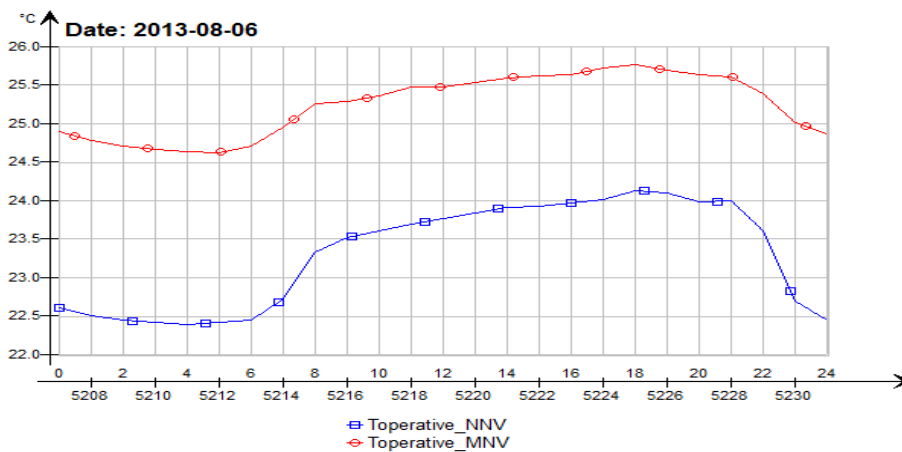

Figure 80 Operative temperature trends during day August 6th.

This operative difference temperature reflects in the solar shading use.

Solar shading control is automatic and based on temperature; when it is above 23°C the external awnings start to overshadow the glazed surface. The covering is not done in a sudden way but it is proportional: the output control varies between 0 (fully bared) and 1 (fully shaded). Figure 81 shows the two different work operation. Two windows for each orientation have been selected to present the shading control; nevertheless, being a temperature based control it works in the same way for all the windows. What it worth to stress is how for MNV model the solar shading is always active between June and half of September during day and night. The first weeks of August (the warmest period), the output varies between 0.5 and 1, achieving a complete covering of all glazed surface.

For NNV, the output is 0 during night and not always 1 during day. There are days in which the windows are completely shadow (as for MNV) but mainly the glazed sur-

face is not always completely covered. This could have consequences on daylight; however the topic will be briefly presented after.

For what concern indoor air quality, the values achieved are extremely good as shown in Figure 82.

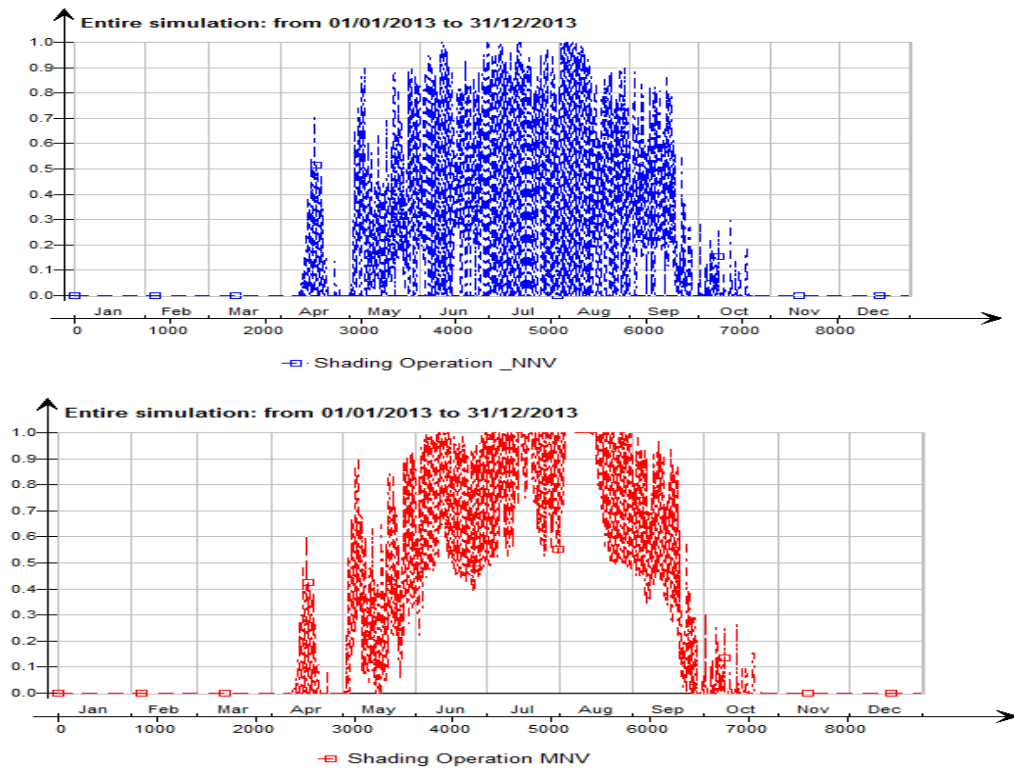

Figure 81 Shading operation graph for Natural night ventilation (upper) and for Mechanical night ventilation (lower); eight windows have been selected, two for each direction⁸

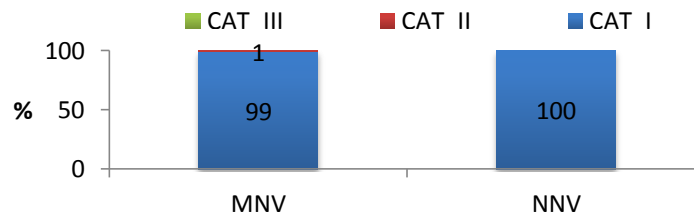

Figure 82 Indoor air quality categories according En 15251 for the whole year

⁸ The number of the windows refer to Figure 16 and Table 6

7.4 Qualitative analysis of windows opening width during night

Security and noise problem can seriously lead people to not accept natural night ventilation.

To evaluate in a qualitative way the two problems risk importance, a windows opening width analysis has been done. Considering that 28.4 cm is the maximum width opening, seven ranges of 4 cm size have been determined. Through a dedicate excel sheet, each range time opening percentage has been calculated Figure 84(upper) shows the results through a histogram; a complete table is reported in Appendix E. Because type A1 and A2 windows operate in the same way, a representative for each type has been considered.

All the windows behave, more or less, in the same way: 12% of the time fully opened⁹ while most of the time (70%) they are opened on minimum range. Windows 16 is the only one behaving differently, even if it similar to windows. For half on the time (50%) it is opened in the [4-8] cm range and in [8-12] cm for another 35%.Being the control opening is exactly the same for all the windows, a defect in windows 16 control was hypothesized. Nevertheless, a deeply investigation of this weakness was not done because of the coded Velux's control. Figure 83(lower) shows the histogram with the number of openings hours. Considering that, between May and September the total night hours of possible night ventilation are 1377¹⁰, windows are open, more or less, for 53% of the time (detailed values in APPENDIX E).

The windows in a critical position for security are those one of the ground floor (16-17-18-19). Useful it could be to understand for how many minutes the windows are opened in all the ranges. Being hourly-time-step simulations, it is impossible to give such detailed results. Nevertheless, by taking a look to the opening distribution it is reasonable to exclude significant security risk. The daily opening distribution for is shown in Figure 84 for all the windows while in Figure 85 only for ground floor ones. The biggest size ranges are reached only the first hours of the night when the inside temperature is above the threshold and a large amount of outside fresh air from is needed to cool down the zone. Keep going during night, the air flow needed reduces and indeed, the opening width is smaller, most of the time below 12 centimeters.

⁹ Respectively according with their maximum width:[24-28] cm for windows 16-17-18-19-20, [20-24] cm for windows 2-8-20-21-22-23.

¹⁰ Nine hours (from 10 p.m. to 7 a.m.) per night for 153 days.

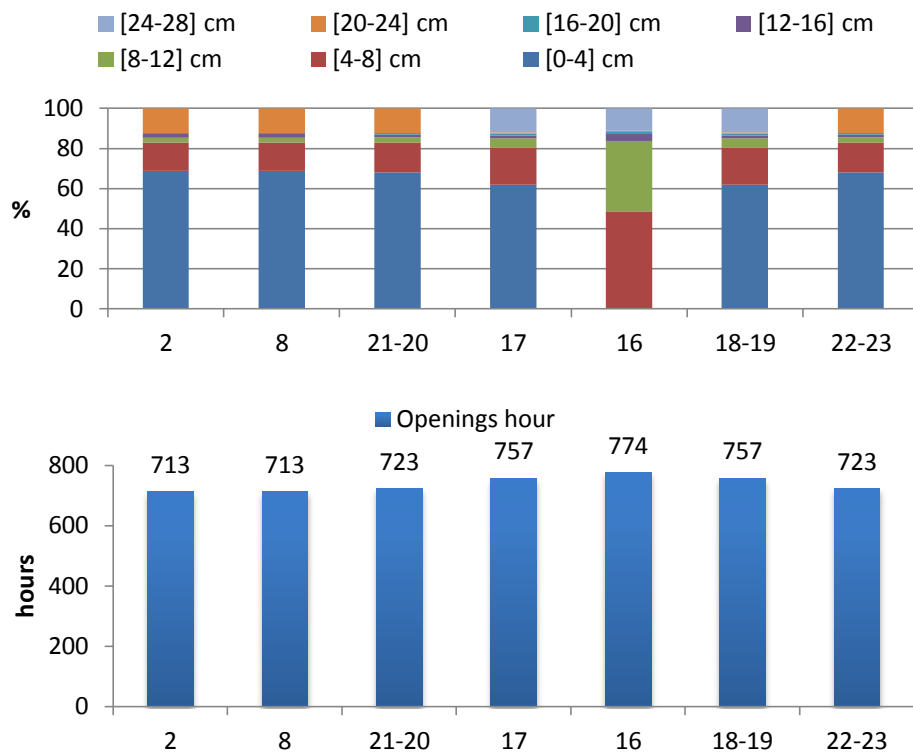

Figure 83 Percentage of width range for windows interested in the natural ventilation (upper) and opening hours per each window (lower)

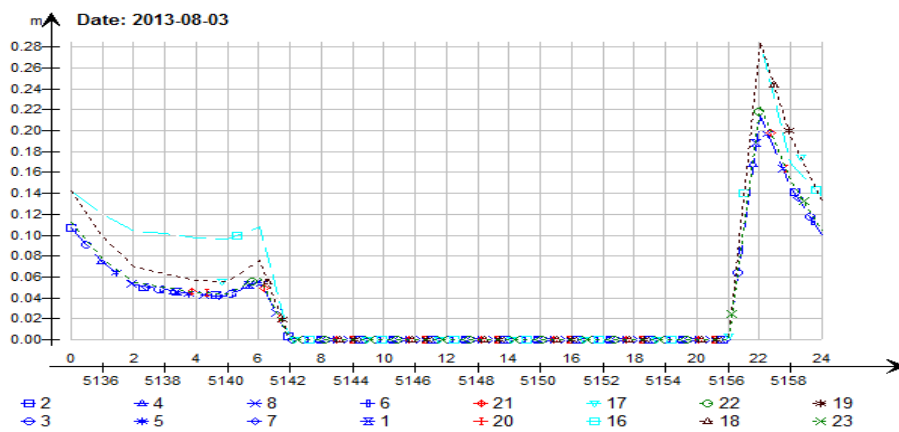

Figure 84 Opening width diagram during day August 3th (screen damp from Velux EIC)

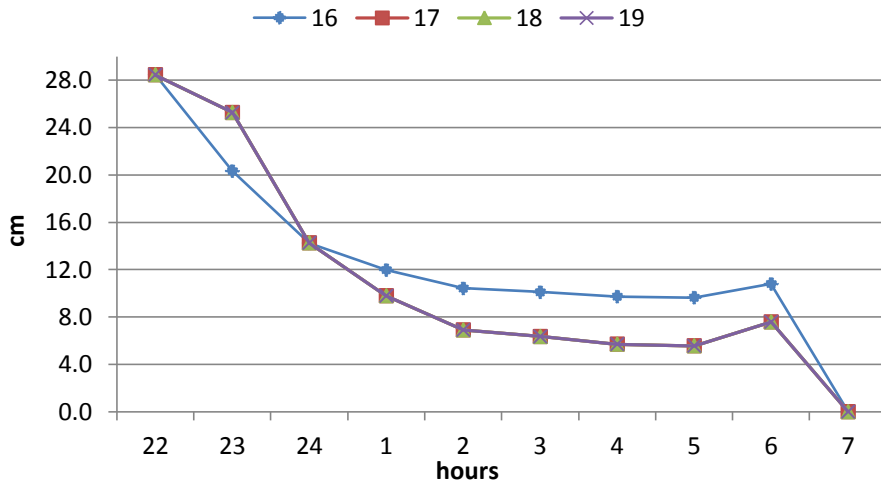

Figure 85 Opening width diagram for ground floor windows during the night between August 2th and 3th

Whit this qualitative analysis it is demonstrated how such small width openings are not so relevant for what concern security and noise. By the way, when buildings are located in high density urban areas, the use of gratings for windows situated in lower floor is recommended otherwise people, minding about their security, will be always inclined to close windows, loosing natural night ventilation benefits.

7.5 Shading and daylight analysis

In paragraph 7.3 the shading operation graphs were presented. As pointed out, the way in which the external awnings work is different between the two case studies. Here a quick daylight analysis is done to understand how the intensive use of the solar shading can affect it.

The software Velux EIC calculates the amount of daylight entering the building as an average of the lux level over the floor. The daylight model calculates the target position of the direct light beam from each window. Each surface that is hit will then reflect diffusely. A radiosity model is applied to negotiate diffuse light exchange according to approximate view factors.

Using the software outputs, a monthly comparison about daylight, energy required by ventilation system and by artificial lighting was done. The cooling energy demand has not been considered being always zero for both models. The considered daylight values are only between 7 a.m. and 20 a.m. It worth to remember that the artificial lights are turn on when light intensity is 0 lux while are switched off when light intensity is over 50 lux. This last value is enough to guarantee the minimum amount of light for a single-zone residential building. Nevertheless when, in future studies, the model will be carefully designed zone by zone, different lighting values and controls should be considered.

Figure 86 shows the results. As was expected from the solar shading operation, the average monthly values for MNV are smaller than NNV model especially in the central summer months (from July to August). August seem to be the critical one. The mean daylight value for NNV is 4 times bigger. This has an obvious consequence on the artificial light energy demand that is 2-3 times higher for MNV model.¹¹

Also NNV ventilation energy demand is lower even if it is, above all, due to the use of windows opening to flush fresh air from outside to inside instead of using the fan.

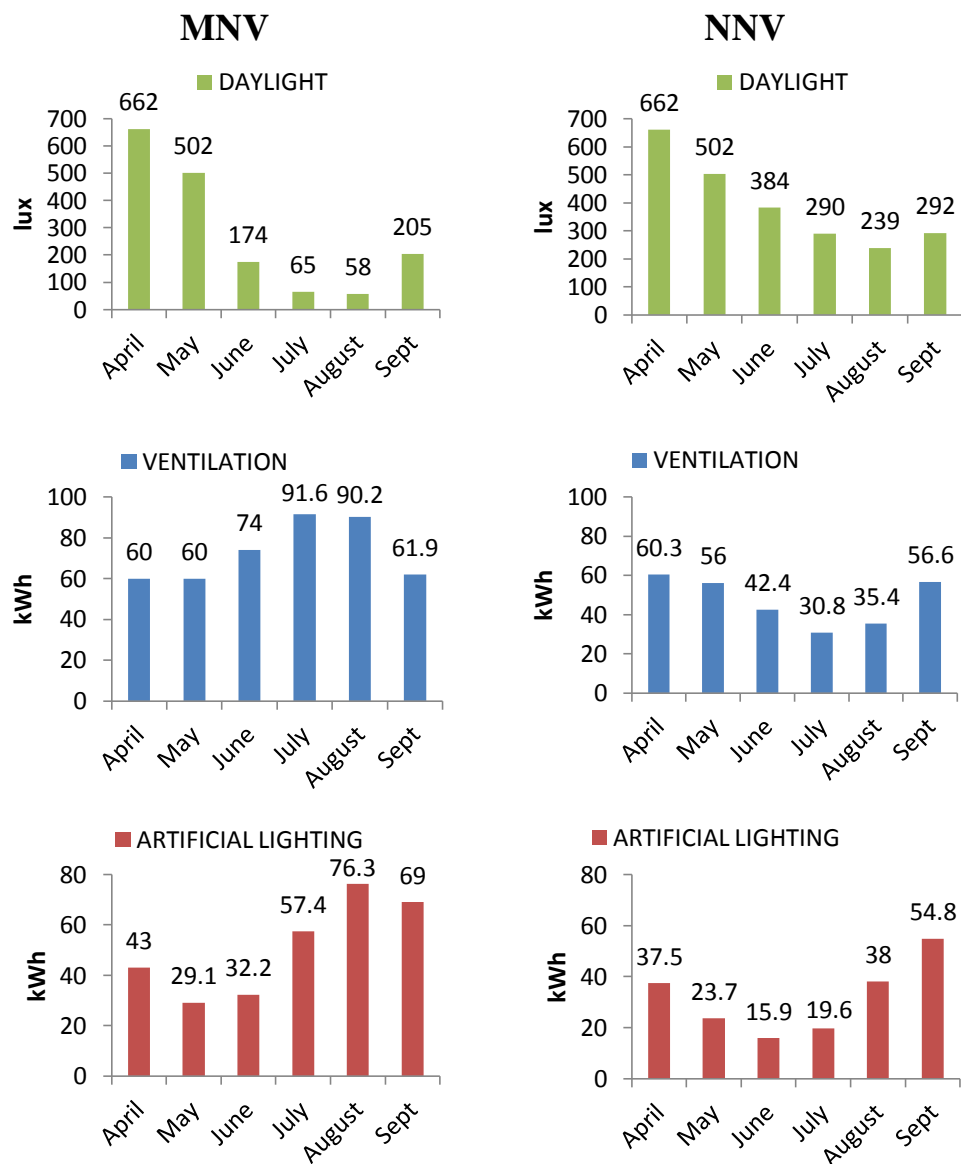

Figure 86 Monthly values of daylight, energy for ventilation and for artificial lighting

¹¹ It has to be underlined that the artificial demand is already counted in the total energy demand. Actually, being the lights considered as an internal gain, their consumption is taken into account as a positive gain in the calculation of the heating demand and as a negative one in the calculation of the cooling demand.

Work up to this point, it seemed also proper to analyze the daylight response to a different shading set-point. For this reason two new simulations were designed with 26°C solar shading set-point. The results are directly compared with 23°C.set-point. To make the comparison more direct an average value for the period April-September was evaluated.

Figure 87 shows the compared results. With 26°C set-point the average daylight value is 2 times higher for NNV and 2.5 times for MNV. Nevertheless the cooling demand is not zero and also MNV ventilation demand is higher.

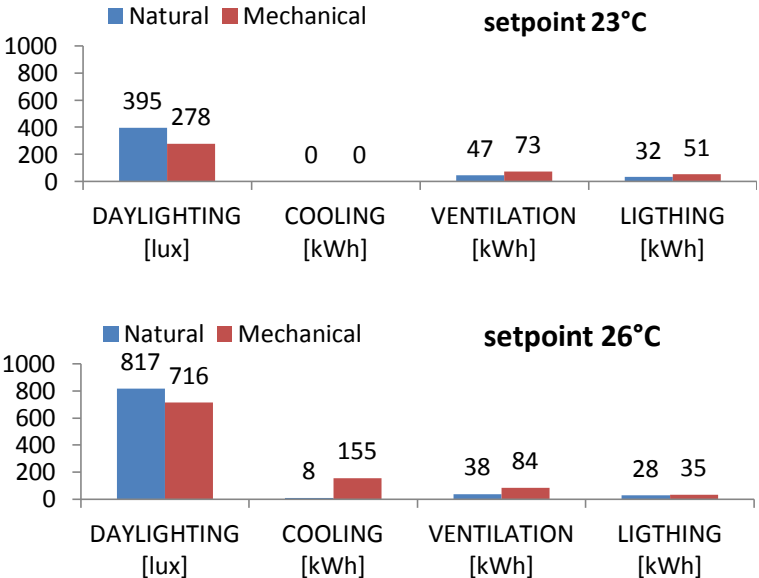

Figure 87 Compared results for two different solar shading set-points

Table 28 shows the total energy demand comparison. If people will choose more daylight inside the building, this will affect increasing the total energy demand by 21% with MNV while, this has no influence for NNV. In both cases, the solar shading will work when strictly necessary, guarantying a comfortable indoor environment. When indoor temperature is above 26°C, indeed, also the glazed temperature surfaces will be protected from overheating.

Table 28 Total Energy demand for two different solar shading thresholds

Total energy demand [kWh/m ² year]	setpoint 23°C	setpoint 26°C
MNV	46,2	58,3
NNV	44,6	44,2

7.6 Effect of automatic control of open windows on Indoor environment

The dedicate control for daytime natural ventilation has been already faced in paragraph 4.3.

The previous analysis pointed out how the opening of all the façade doors (type B and C Table 6) does not have influence on the energy demand, thermal comfort and indoor air quality. For this reason a new windows opening configuration has been thought.

The windows now interested by the daytime ventilation are:

- 20 and 21 (Type E1-orientation SOUTH-EAST);
- 18 and 19 (Type D2- orientation NORTH-WEST);
- 9 and 10 (Type B-orientation SOUTH-WEST);
- 14 (Type C-orientation NORTH-EAST).

The selection is not random; first of all, the wind rose (APPENDIX A) and the monthly average velocities for each direction have been considered. Then, windows in all the orientation were selected to create cross ventilation for both building direction (sectional and axial). Two first floor windows (20 and 21) are considered because windows opened in that position can help to flush out the exhaust air, warmer and rich of pollutant, stacked just below the ceiling.

As before a qualitative analysis of windows opening width is done. Through an excel sheet the opening width values at 7 a.m and 5 p.m. have been separated from the rest during the period between April 10th to October 21th.¹²

The percentage of each range size and the total hour's number has been evaluated, as in paragraph 7.4

A simplified calculation of the air velocity average value that people can eventually experience moving close to the windows was also done. For each window hourly air velocities are calculated as ratio between the total air flow and the opening area. Then, averaging the hourly values for all windows, a unique average value is extracted. Same method has used for the hourly air velocity maximum value After this, only values at 7 a.m. and 5 p.m. are counted and graphed Finally, averaging all the average hourly values, a unique average and maximum values are obtained plus standard deviation ,shown in a table.

The eventual effect on thermal comfort, energy demand and indoor air quality were investigated.

¹² April 10th is the first day in which the thermal conditions are reached while October 21th is the last day.

7.6.1 Windows opening ranges

Figure 88 and Figure 90 show opening width range percentage both at 7 a.m.(upper) and 5 p.m.(lower) respectively for NNV and MNV.

Considering the 7 a.m histograms, it is clearly visible that when night natural ventilation is used the opening ranges are the smallest ones (0-4 cm and 4-8 cm) while with MNV ranges distribution is quite uniform. In this second case the biggest ranges are reached even if, for the majority of the time, the windows open in 4-8 and 8-12 cm ranges. This means that NNV model is more efficient in keeping the indoor temperature under the threshold, that no large amounts of fresh air in the morning are needed. Different considerations come from 5 p.m. histograms. During all the day (from 8 a.m. to 5 p.m.), except weekend days, the ventilation system is not working (being the dwelling not occupied), the windows are all closed and the only system that prevents temperature increased is the solar shading. For all these reasons, at this time of the day the need of fresher outside air is higher compared with morning. This need is visible reflected in the opening width percentage. All the ranges are covered for both models but with a difference: while for NNV range [12-16] cm has the highest percentage (more or less around 25%) with MNV model, for the majority of the time (around 34%), the windows are opened with the biggest ranges ([20-24] cm and [24-28] cm). This behavior is again related with the different cooling potential of the two ventilation methodologies. The mechanical ventilation system is not able to keep such lower temperature during night as the natural one and this reflects with a higher temperature increase the day after. The concept is clearly expressed by Figure 91 where the operative temperatures trends are showed for one of the warmest summer period days.

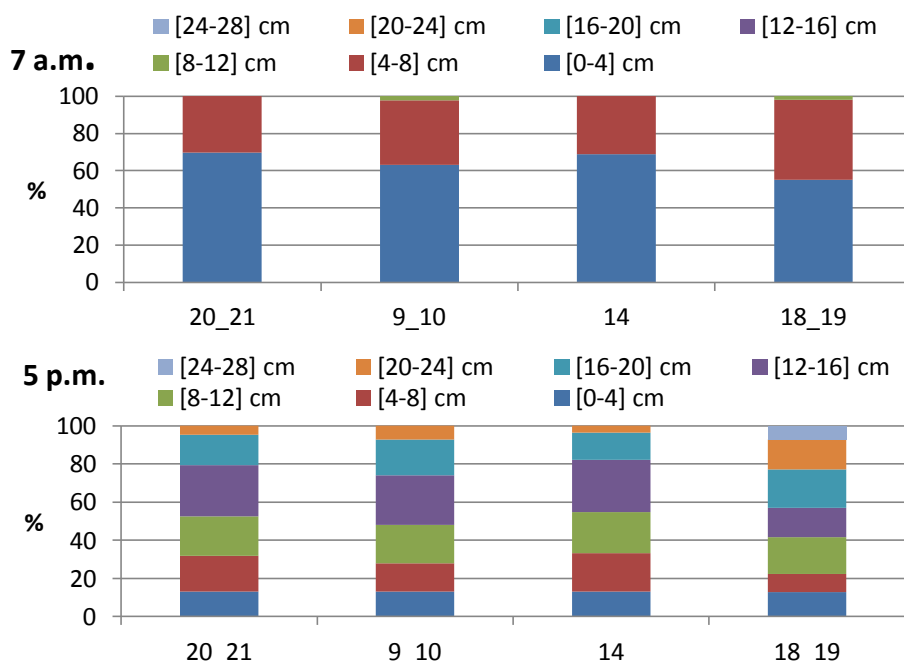

Figure 88 Opening width percentage ranges NNV at 7 a.m. (upper) and 5 p.m. (lower)

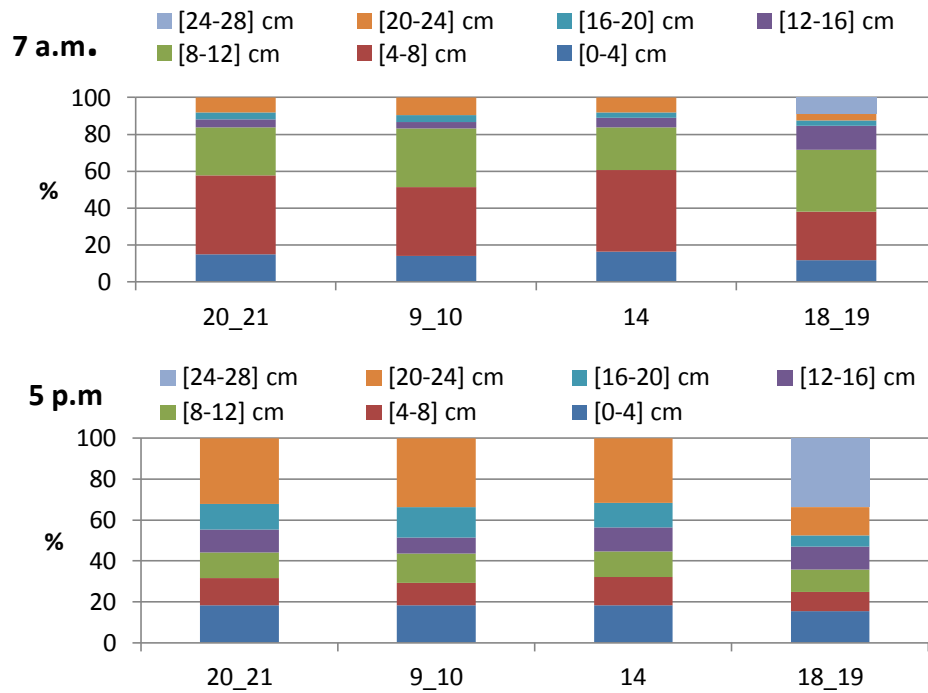

Figure 89 Opening width percentage ranges for MNV at 7 a.m. (upper) and 5 p.m. (lower)

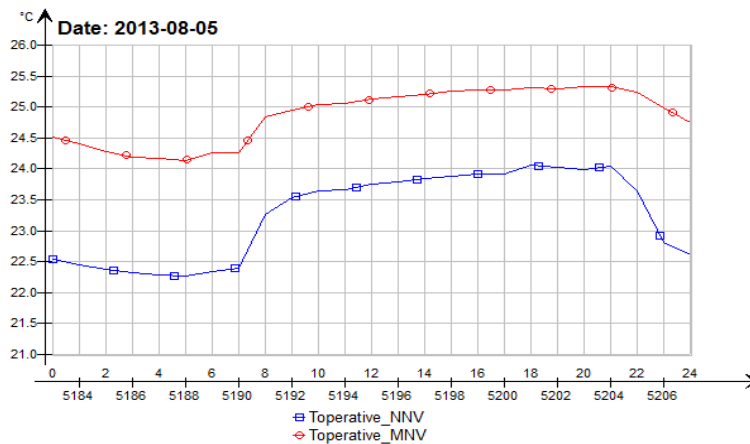

Figure 90 Operative temperatures comparison for day August 5th

What it is interesting to stress is the influence of windows orientation on the opening width range distribution. In particular, windows that face NORD-WEST (windows 18 and 19) and SOUTH-WEST (windows 9 and 10) are those ones with in the higher width ranges biggest percentage. This occurrence is also more evident for MNV. Nevertheless it worth to remember that the windows are opened only for 15 minutes and so probably the time in which the maximum width are reached is just few minutes.

Figure 92 shows the different automatic control use between morning and afternoon. For NNV model the opening in the afternoon is preponderant while for MNV model the difference is less strong but moved toward a major use in the afternoon too.

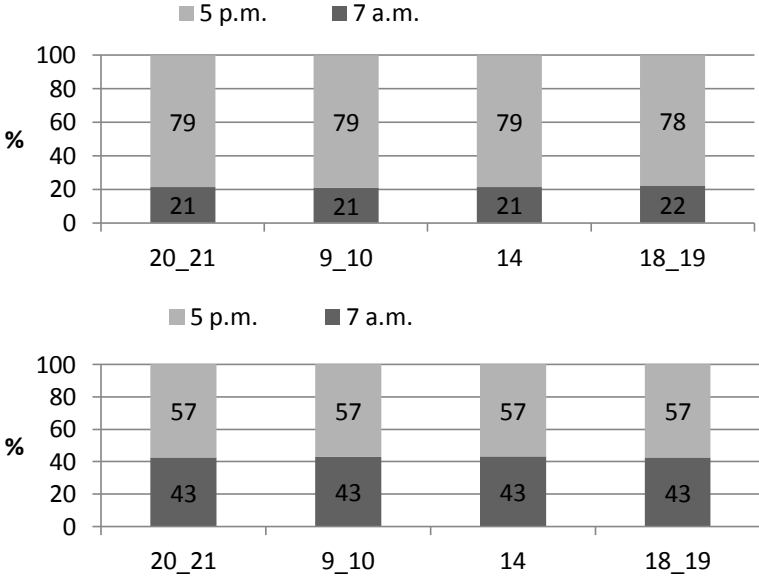

Figure 91 Opening percentage distribution between morning and afternoon for NNV(upper) and MNV(lower)

7.6.2 Air velocity analysis

In this paragraph the results about air velocity analysis are collected. These velocities are those one people can experience if close to the windows and placed in the air flow direction coming from outside. Figure 92 and Figure 93 show the average and maximum hourly air velocity values at 7 a.m. and 5 p.m. respectively for MNV and NNV while Table 29 collect the average values of those hourly average and maximum values plus the standard deviation.

There no huge difference between the two models in term of final average values; however, looking at the trends some comments can be done. At 5 p.m, while for MNV 2.4 m/s (and even more) is the maximum reached values, for NNV , with the exception of only two values close to 2.3 m/s, the other ones are always under 1.6 m/s. This seems again related with the different openings width between the two methodologies. The other observation refers to trend air velocities at 7 a.m.: when the natural night ventilation is used the windows opening frequency the days after is lower than with the mechanical one. In fact the number of points, that means a value for that hour, is inferior. The NNV diagram is indeed values (points) less dense.

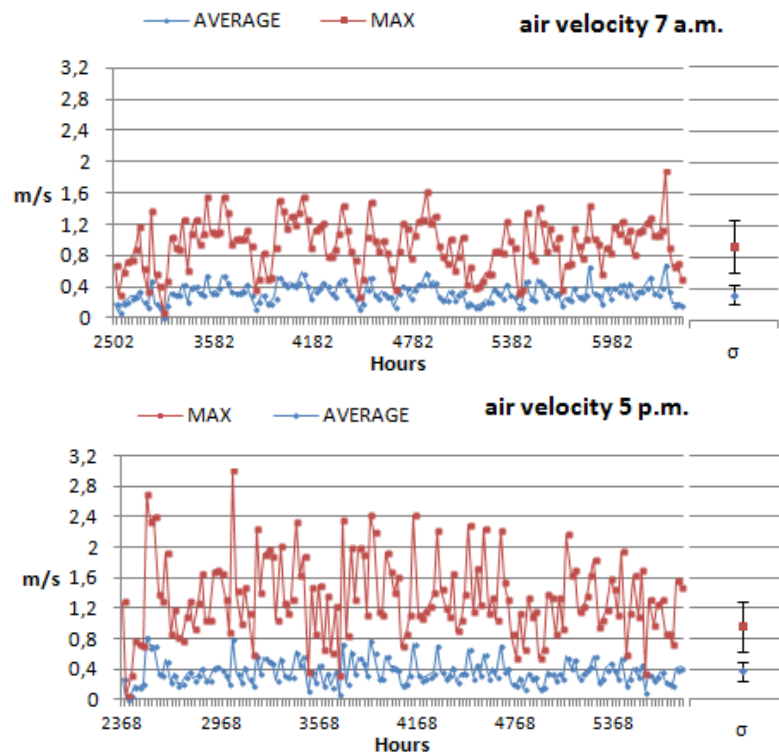

Figure 92 Trends of the average and maximum hourly values of velocity for MNV model at 7 a.m and 5 p.m

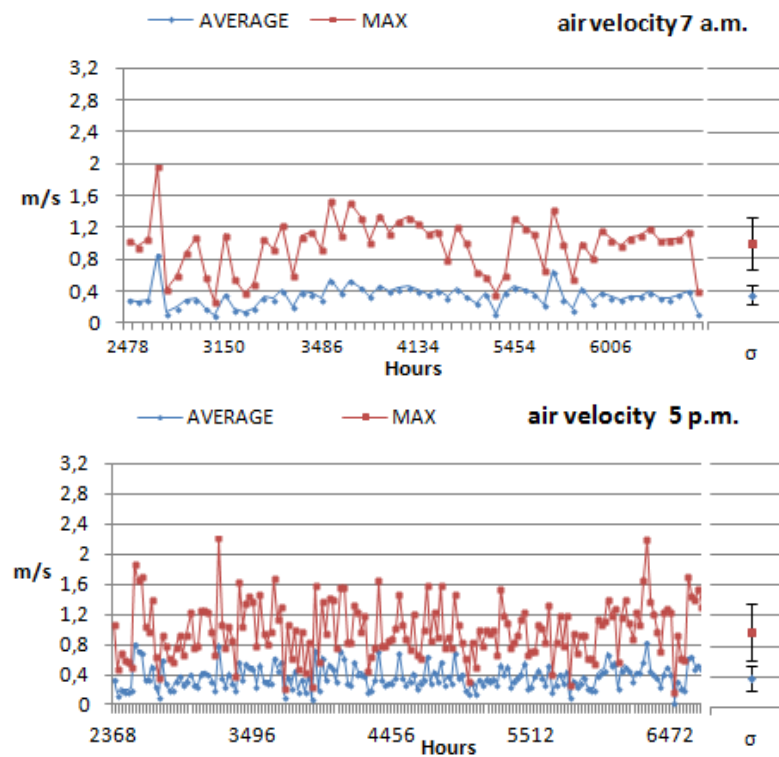

Figure 93 Trends of the average and maximum hourly values of velocity for NNV model at 7 a.m and 5 p.m.

In APPENDIX G, Figure 124 reports the number of time in which each windows open in the morning and in the afternoon. For MNV opening times at 7 a.m. is more or less 3 times more frequent while only 7% more at 5 p.m.

Table 29 hourly velocities comparison.

MNV			NNV		
Hour [h]	Average [m/s]	Maximum [m/s]	Hour [h]	Average [m/s]	Maximum [m/s]
7 a.m.	0,33 ± 0,12	0,94 ± 0,33	7 a.m.	0,35 ± 0,13	0,99 ± 0,33
5 p.m.	0,37 ± 0,17	0,99± 0,40	5 p.m.	0,38 ± 0,13	1,0 ± 0,38

Table 30 gives a review of models main characteristic for April-October period. he dates collected are: average operative temperatures plus standard deviation, average humidity plus standard deviation, an average value of the indoor air velocity calculated with methodology described in paragraph 2.5., PMV (predicted mean vote) and PPD (percentage people dissatisfied)¹³.

Table 30 Thermal indoor environment characteristics for both models

Case studies	To ± σ [°C]	Vindoor [m/s]	RH ± σ [%]	PMV	PPD [%]
MNV	22.5 ± 1.4	0.36	48 ± 9	-0.5 ± 0.2	14 ± 6
NNV	22.2 ± 1.1	0.38	50 ± 10	-0.5 ± 0.2	11 ± 4

According to thermal comfort categories of ISO 7730 [9], both night ventilation strategies are in the edge between categories B and C. Nevertheless, the values refer to the entire period and if a look in taken to Figure 125 of APPENDIX G, it seems clear that months which compromise in a negative way the average value are April and October. For these months, a future careful study should be taken.

7.6.3 Energy demand, thermal comfort and IAQ

No relevant changes were observed for thermal comfort and indoor air quality (Figure 95); just a little improvement in the total energy demand for the MNV, only 1.3 % less (see Table 31). Therefore it is possible to conclude that automatic control use for daytime airing, based a possible human behavior has no negative effects. Actually it

¹³ The software limits in calculating the value of PMV and PPD were already described in paragraph 2.1 about the building characteristic.

can help to reduce, even if in a slightly way, the energy demand when for security and noise problems the use of a mechanical night system is preferred to a natural one.

Table 31 Airing daytime ventilation effect on the energy demand

Total energy demand [kWh/m ² year]	only night ventilation	plus daytime natural airing
MNV	46.2	45.6
NNV	44.6	44.6

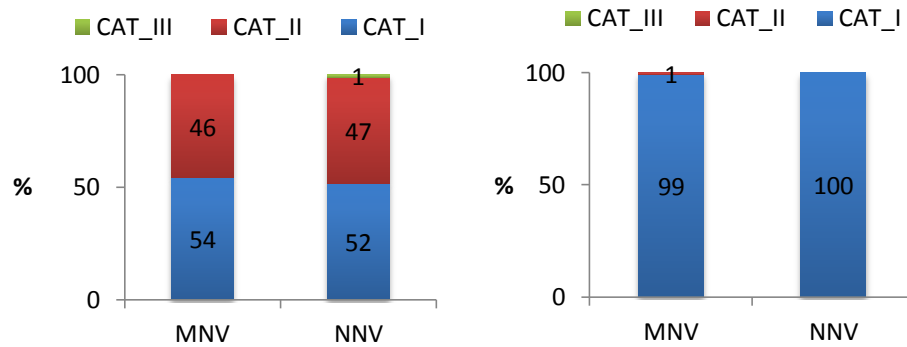

Figure 94 Thermal comfort (left) and IAQ (right) for behavior ventilation

8. EFFECT OF SCANDINAVIAN BEHAVIOR ON ENERGY DEMAND

in the previous chapter, the effect of two different strategies of night ventilation were investigated in term of energy demand and indoor environment. The set-points used for the building model systems, were in accordance with the recommended standard values ([45]). In particular, for the cooling system, 26°C was adopted as Indoor air temperature for the control system's set point and results showed that, for Copenhagen climate, the cooling system is not needed as it resulted never working when night ventilation strategies (natural or mechanical) are exploited.

Even though the standards recommendations for designing heating and cooling systems were respected in the previous analyses, in this chapter more focus will be given on people satisfaction with the indoor thermal environment. Customs, habits and adaptation to cold climate could have an important impact on the control systems. All year around, Danes are exposed to temperatures that are generally below 25 °C barely reaching 27 °C at the warmest time (1st week of August), as shown in Figure 95. This consideration may allow to accept that Scandinavian people do not tend to accept 26C as acceptable indoor air temperature and they may choice to decrease the temperature set point of cooling system and/or to use other cooling strategy at the expenses of the energy consumption. In addition, when looking at the Danish residential stock, it was noticed that no solar shading or curtains are often installed and/or used. It may result in pleasant indoor natural light and sun radiation but, on the other hand, also in unpleasant increased of temperature which can instead see the users to act by lowering the temperature set point of the thermostat as first action.

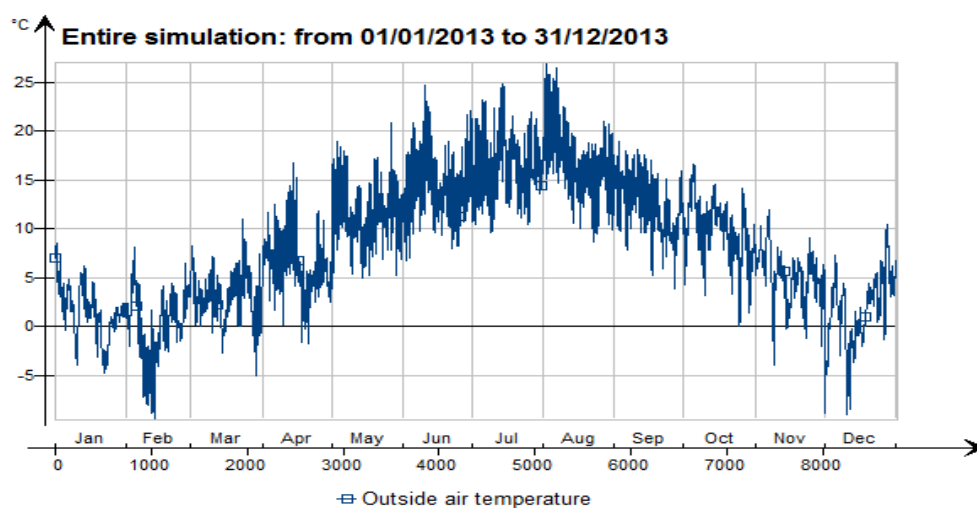

Figure 95 Copenhagen outside air temperature trend for the whole year

Behind those considerations, only confirmed by personal experience, two new simulation's models were designed with 23°C –set-point for the cooling system and as first step also without application of solar shading but keeping the use of night cooling ventilation.

It worth to summarize the main features of these case studies:

- Heating set point: 20.5°C;
- Cooling set point: 23°C;
- Threshold for windows opening(NNV) or variable air volume ventilation system(MNV): 23°C;
- Solar shading threshold: 26°C(this is equal to not considered at all the solar shading effect because the cooling system will keep the operative temperature always under that threshold).
- Heat recovery ventilation still used with 0.85 heat exchanger efficiency.

8.1 Results

By lowering the set-point the total energy demand is clearly higher (Figure 96) although the night ventilation use can still bring energy saving. Compared with the reference model (M_HC) MNV has a smaller consumption (9% less) while with NNV around 18%.¹⁴

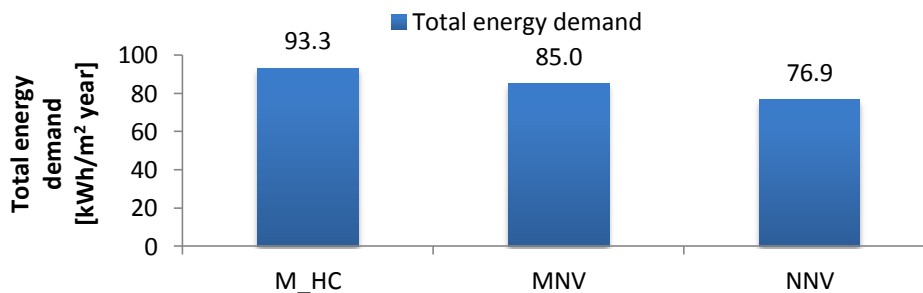

Figure 96 Total Energy demand for the alternative night ventilation strategies and for the reference model when no solar shading is used

The new calculated energy demand of the building is reported in Figure 97 for the different applied systems. For both night cooling strategies the cooling demand is around 60% higher than the heating one.

¹⁴ The percentage refers to a comparison with M_HC model.

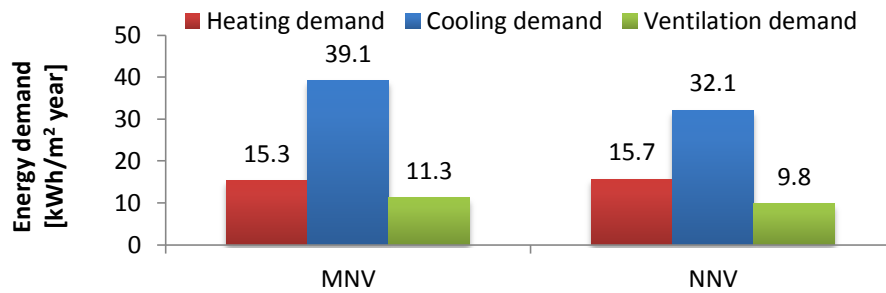

Figure 97 Distribution of energy demand when no solar shading is used.

When the cooling set-point was 26°C and passive strategies were applied the energy demand was 46.3 kWh/m² year for MNV and 44.6 kWh/m² year for NNV. Else when 23°C was the cooling set-point, without solar shading use, the total energy demand was 46% higher for MNV and 42% for NNV. See Figure 98.

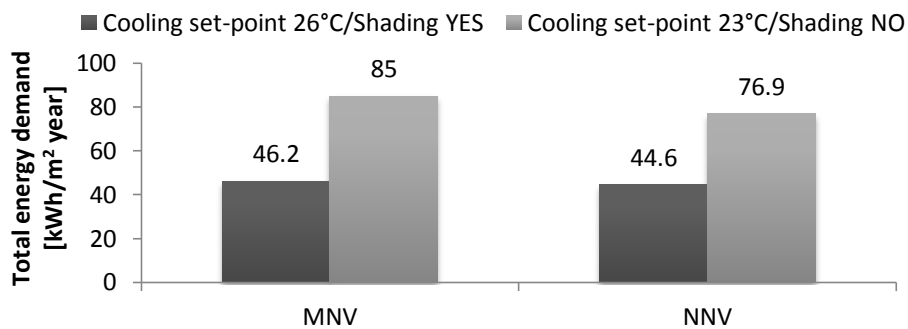

Figure 98 Comparison in term of total energy demand when cooling set point and use of solar shading are used in different ways.

Such high energy demands do not suite Danish regulation limits ([48]) although they may reflect the real (future) consumption due to the real users' behavior.

Solar shading prevents indoor temperatures raise that cannot be avoided. in fact, considering the higher energy demand and looking to the operative temperature trends in Figure 99, a new simulation model with the use of sun reduction systems was designed having as set-points:

- 23°C for the cooling system;
- 23°C for the activation of solar shading use.

The shading set-point was chosen considering the temperatures trends of Figure 99. It is clear that even if the cooling system is ON keeping the indoor air temperature at 23°C, the nonuse of solar shading will impact on the perceived temperature by the occupants as the operative temperature is fluctuating.

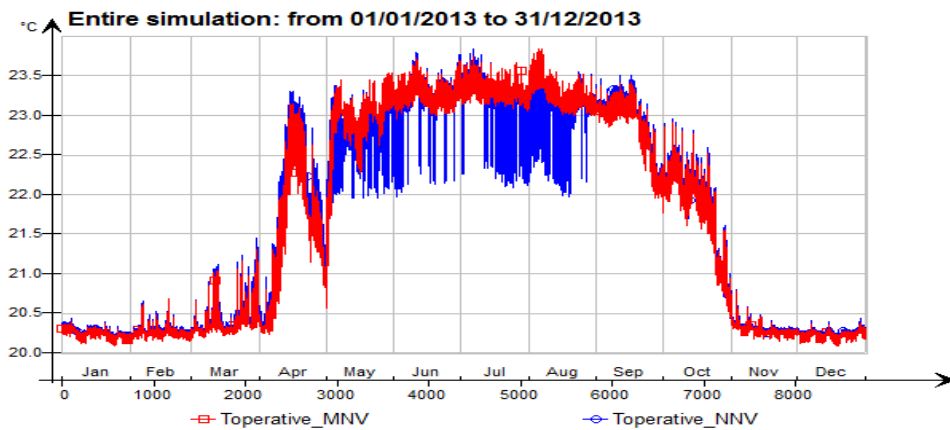

Figure 99 Operative temperature trends with 23°C cooling set-point and without solar shading

By using the 23°C set-point solar shading, the 20-23% of total energy demand can be saved (Figure 100)

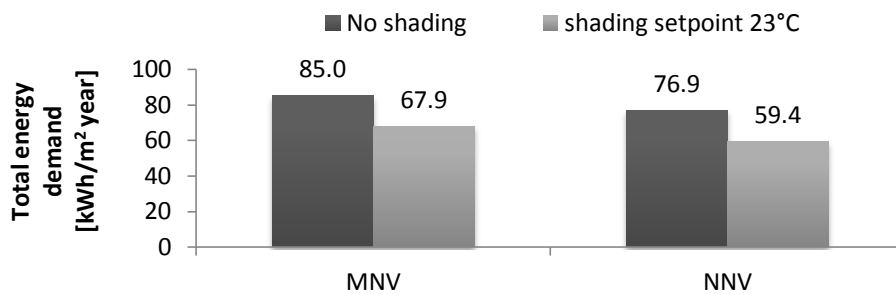

Figure 100 Total Energy demand comparison for the two case studies without and with solar shading

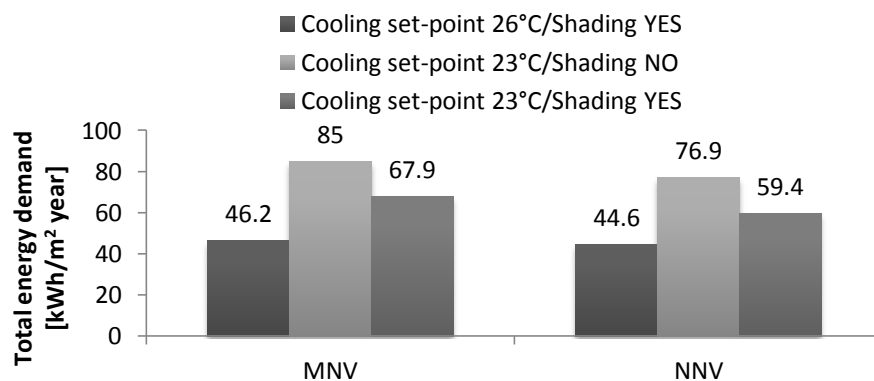

Figure 101 Total energy demand for different set-points combination

The effect of changing only cooling system set-point, passing by 26°C to 23°C, reflect in extra energy demand: 32% and 25% respectively for MNV and NNV (see Figure 101).

Figure 102 shows the annual temperature profiles with: the black line (no solar shading) is always over the grey line (shading set-point 23°C) highlighting once more the big influence of blocking solar radiation on operative temperature increases. By using the solar shading, daylight problems could rise. By the way, checking the shading operation (Figure 103), being the output control always no more than 0.5, the windows can be maximum half-covered. Hereby, even if the monthly daylight values have not been analyzed, it can be assumed, considering also the results of paragraph 7.5, that the daylight is not deeply prejudiced.

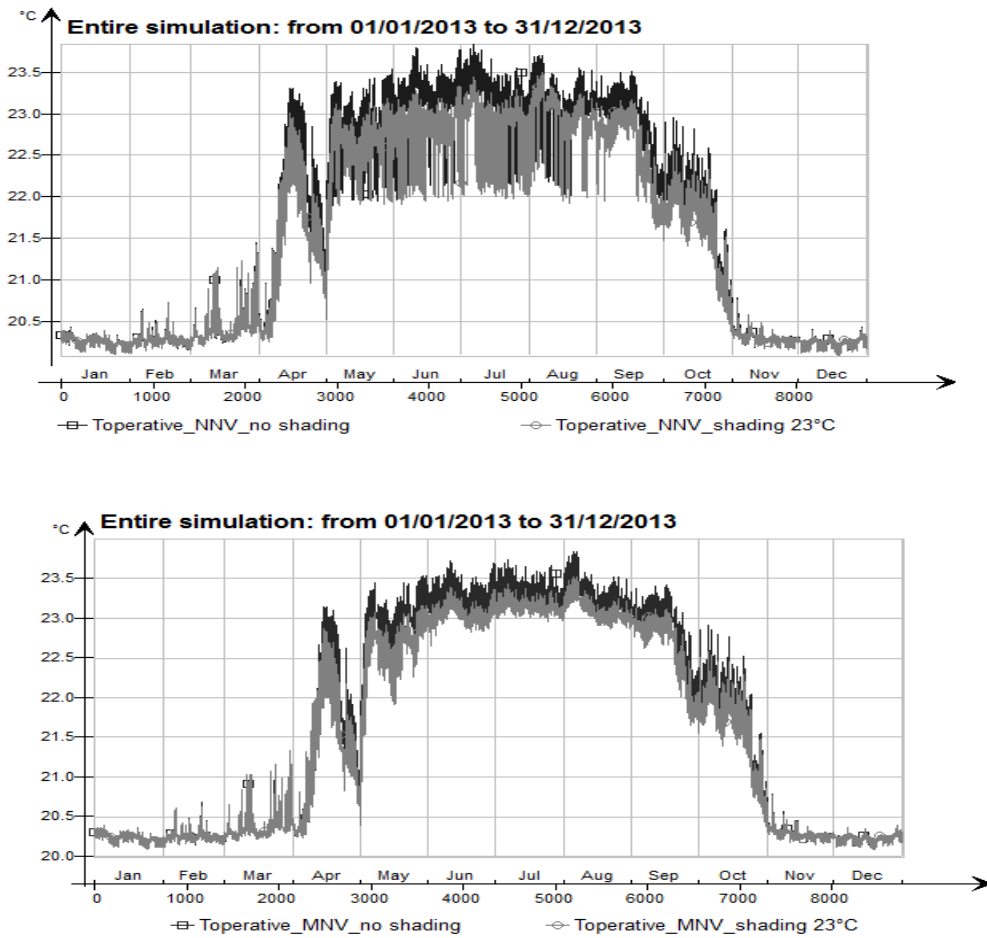

Figure 102 Operative temperatures profiles under different solar shading condition NNV(upper) and MNV(lower)

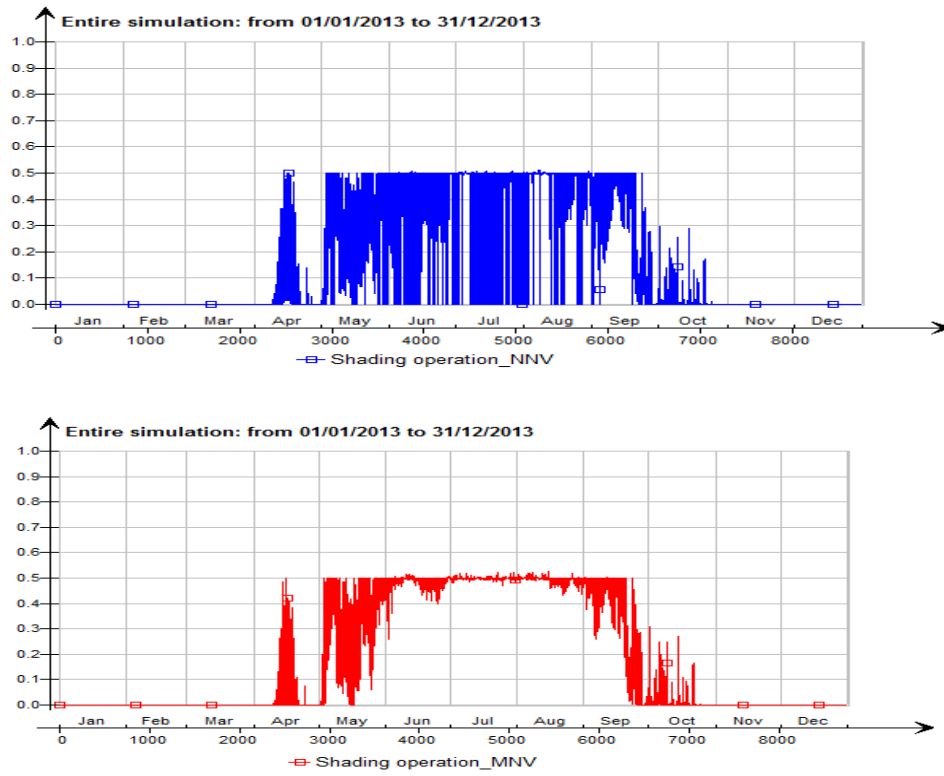

Figure 103 Solar shading operation with 23°C set-point, NNV (upper) and MNV (lower)

9. CONCLUSIONS

In this section, the reached conclusions from the main results are presented according the order followed when analyzing the impact of different factors on the energy consumption, indoor air quality, and thermal comfort for a low energy residential building in Copenhagen climate.

9.1 Passive strategies analyses

The effect of passive cooling strategies was analyzed for low energy residential buildings in Danish climate in order to describes or eliminate the newly rising overheating issue.

The passive cooling strategies, as solar shading and night ventilation, were analyzed separately and coupled for two building models having different structure of the envelope. The building with higher insulation increased by 61% on cooling demand proportionally with 69% decreasing of heating need.

The simultaneous use of solar shading and natural night ventilation leads to a cooling demand reduction that varies between 98%-100%, respectively for STRUCTURE A and STRUCTURE B, showing how in these new concept buildings the cooling system can be completely replaced with environmental/energy friendly solutions as passive strategies.

Lower envelope dissipation (STRUCTURE B) impacted on the ventilation system making the heat recovery ventilation essential to reach proper energy demand. When air-to-air heat exchanger was ON 71-73% of energy saving was achievable.

By using coupled passive strategies and heat recovery ventilation (M_HC_SNa_HRV model), 30% savings of total energy demand resulted in building's structure A and 51% in building B.

The performed simulations showed also that the application of solar shading becomes more important for highly insulated buildings in summer time when the increased indoor temperature may be longer maintained causing thermal discomfort.

The simulated M_HC_SNa_HRV model performed the best results in terms of energy demand and indoor air quality, no matter for the buildings' structure, with a low impact on thermal comfort evaluation.

Besides, in well insulated building (B), the operative temperature was kept at 24 °C (<26 °C) due to the higher air change rate (2ach) during the natural night ventilation, surely preventing overheating problems. Building structure B was chosen according the thermal proprieties stated in the new Danish building regulations which will be applied from 2015 on the new residential buildings in Denmark. Further analyses were performed with the building model M_HC_SNa_HRV on building structure B.

9.2 Natural night ventilation vs Mechanical night ventilation

When for security and/or other reasons the opening of the windows during the night is not possible or suggested the alternative use of an active cooling by night-air through the mechanical ventilation system (MNV) was evaluated. The results showed that with a maximum increased of air change rate to 1 in the night, the MNV method was sufficient to compensate the cooling energy need against an increase of 3.5% of total energy demand due to an increased use of the fans of the ventilation system.

Different resulted the building's behaviour when the two night cooling ventilation strategies were applied. In summer, the indoor air temperature (close to 26 °C) was higher (up to 2 °C) and more constant when the MNV model was considered against the natural night ventilation through the windows opening (NNV).

When NNV model was studied, an higher drop of indoor air temperature was noted with the consequence reduction of solar shading use, which resulted in two positive effects:

- use of natural daylight for building's users, and
- no additional cost on energy demand (equal to 21% in MNV).

The security and noise issues, when natural night ventilation was used, were reduced in intensity by ensuring the low windows opening width.

The automatic control for daytime ventilation, when considering the occupants' behaviour, did not compromise neither energy demand nor thermal comfort and indoor air quality, allowing some freedom actions to the building's users.

When considering the possibility that lower indoor air temperature is required by the occupants ($t_a=23^{\circ}\text{C}$), the results from the simulations reported:

- 32% (MNV) and 25% (NNV) increased total energy demand;
- 46% (MNV) and 42% (NNV) increased energy demand when at the same time no solar shading is used.

9.3 Further continuation of the study

The results of the investigated systems strategies for reducing the nowadays increasing issue of overheating in cold climatic region, like Copenhagen, for low-energy houses should be considered for further studies where others systems and strategies could be applied with regards of reduction of cooling energy demand, indoor air quality and indoor thermal comfort.

Interesting could be to investigate the effect and impact of different type of heating and cooling systems, such as thermal panel, and/or radiant heating/cooling floor and/or ceiling coupled with ground source heat exchange .

Being the analysed building model very flexible, additional investigations could be performed when adapted to different climatic conditions.

More investigations should be done considering people's behaviour and their interaction with the building for the future match between building designer's solution and users' management.

Moreover, the impact of night cooling strategy on occupants' sleep quality could be studied.

The work done in this master thesis project should be the start point for further interesting studies that will ensure people life comfort with respect of the energy issue.

10. REFERENCES

- [1] The Directive 2010/31/EU of the European Parliament and the Council of 19 May 2010 on the Energy performance of buildings, Official Journal of the European Union, 53, 2010.
- [2] Bogdan Atanasiu. **Principles for Nearly Zero Energy Buildings**. Final Draft 2011 (BPIE)
- [3] <http://www.bfrc.org>
- [4] http://passiv.de/downloads/03_certification_criteria_transparent_components_en.pdf
- [5] Jarek Kurnitski, Francis Allard, Derrick Braham, Guillame Goeders, Per Heiselberg, Lennart Jagemar, Risto Kosonen, Jean Lebryn, Livio Mazzarella, Jorma Railio, Olli Seppänen, Michael Schmidt, Maija Virta. **How to define nearly zero energy buildings nZEB**. Federation of European Heating, Ventilation and Air-conditioning Associations-REHVA, May 2011.
- [6] EN 15603:2008. **Energy performance of buildings-Overall energy use and definition of energy ratings**.
- [7] Kirsten Engelund Thomsen, Kim B. Wittchen, EuroACE. **European Strategies to move towards very low energy buildings**. Danish Building Research Institute, Aalborg University, 2008
- [8] www.passisedia.passiv.de
- [9] ISO 7730:2005. **Ergonomics of the thermal environment-Analytical determination and interpretation of thermal comfort using calculation of the PMV and PPD indices and local thermal comfort criteria**
- [10] Günter Lang, Lang construction. **International Passive House DataBase.eu-1. Period of documentation 2007-2009, 25000 Passive House project in Europe**. Vienna, November 2010
- [11] www.pass-net.net/about/project.htm
- [12] Malcolm Orme, John Palmer, Steve Irving **Control of Overheating in well-insulated Housing**, FaberMaunsell Ltd
- [13] Tine Steen Larsen, Rasmus Lund Jensen, Ole Daniels. **The comfort Houses- Measurements analysis of the indoor environment and energy consumption in 8 passive House 2008-2011**. Department of Civil Engineering Aalborg University, January 2012
- [14] Ulla Janson, **Passive House in Sweden-From design to evaluation of four demonstration projects**. Division of Energy and Building Design, Department of Architecture and Built Environment, Lund University, Faculty of Engineering LHT, 2010
- [15] <http://www.shadinglouvers.com/solar-shading-systems/exterior-timber-louver-solar-shades/>
- [16] Stephen John, Andy Buchanan, Nicolas Perez. **Environmental impacts of Multi-storey buildings using different construction material**. Research Report 2008-02. University of Canterbury, New Zealand, 2008
- [17] N. Perez, **The influence of construction materials on life-cycle energy use and carbon dioxide emissions of medium size commercial buildings**. Master of Build-

- ings Science Thesis, School of Architecture, Victoria University of Wellington, New Zealand, 2008
- [18] D. Pearlmutter , I. Meir. **Assessing the climatic implication of lightweight housing in a peripheral arid region.** Building and Environment 30 (3), 441-451, 1995
- [19] E. Gratia, I. Bruyère, A.De Herde, **How to use natural ventilation to cool a narrow office building.** Building and Environment 39, 1157-1170, 2004
- [20] O.Seppänen, W.Fisk. **Some quantitative relations between indoor environmental quality and work performance or health.** ASHRAE Research journal. Vol 12, No 4, 2006
- [21] O.Seppänen, W.Fisk,Q.H.Lei. **Room temperature and productivity in office work.** Proceeding of Healthy Buildings Congress 2006. Vol 1, pp. 243-247, 2006
- [22] D.H. Kang, P.H. Mo, D.H. Choi, M.S. Yeo, K.W. Kim. **Effect of MRT variation on the energy consumption in a PMV controlled office.** Building and Environment, 45(2010), pp1914-1922, 2010
- [23] ASHRAE Standard 55-2010. **Thermal Environment Condition for Human Occupancy.** America society of Heating, Refrigeration and Air-Conditioning Engineers, Atlanta 2010.
- [24] ASHRAE. **Fundamental Handbook, Chapter 32 Duct Design.** America society of Heating, Refrigeration and Air-Conditioning Engineers, 1993
- [25] J. Khedari, N. Yamtraipat, N. Pratintong, J. Hirunlabh. **Thailand ventilation comfort chart.** Energy and Building 32(3), 245-250, 2000
- [26] J. Khedari, N. Yamtraipat, J. Hirunlabh. **A new concept for setting thermal comfort standards. Moving Thermal Comfort Standards into the 21st Century,**pp 472-478, Windsor, UK, April, 2001
- [27] N.H. Wong, J.Tanamas. **The effect of wind on thermal comfort in naturally ventilated environment in the tropics.** Proceedings of International Symposium on Building research and the Sustainability of the Built Environment in the Tropics, pp 192-206, Jakarta, Indonesia, 14 October 2002
- [28] Hazim Awbi, **Ventilation of Buildings, second edition.** Spon press, 2003
- [29] <http://www.scotland.gov.uk/Publications/2007/02/28144045/7>
- [30] <http://www.greenspec.co.uk/whole-house-ventilation.php>
- [31] T. Kubota, D.T.H. Chyee, S. Ahmad. **The effect of night ventilation technique on indoor thermal environment for residential buildings in hot-humid climate of Malaysia.** Energy and Buildings 41 (8) 829-839, 2009
- [32] V. Geros, M. Santamouris. **Natural Ventilation in Buildings: A design Handbooks.** James & James (Science Publishers) Ltd., p378, 1998
- [33] D. Etheridge. **Unsteady flow effects due to fluctuating wind pressures in natural ventilation design-mean flow rates.** Building and Environment , 35:321-37, 2000
- [34] A. Sfakianaki, M. Santamouris, M. Hutchins, F. Nichol, M. Wilson, L. Pagliano, W. Pohl, J. Alexandre, A. Freire. **Energy consumption variation due to different thermal comfort categorization introduced by European standard EN 15251 for new building design and major rehabilitations.** International Journal of Ventilation 10 82) 195-.204, 2011
- [35] E. Dascalaki, M. Santamouris. **On the potential of retrofitting scenarios for offices.** Building and Environment 37 (6) 557-567, 2002

- [36] N. Artmann, H. Manz, P. Heiselberg. **Climatic potential for passive cooling of buildings by night-time ventilation in Europe**. Applied Energy 84, 187-201, 2007
- [37] P.Foldbjerg, T.F.Asmussen, K.Duer. **Hybrid ventilation as a cost-effective ventilation solution for low energy residential buildings**. Velux A/S. Proceedings of Indoor Air conference, Austin, Texas, 2011
- [38] T. Pellegrini **Improvement of summer comfort by passive cooling with increased ventilation and night cooling**. Master thesis submitted at Dept. Industrial Engineering, University of Padova, Italy, and ICIEE, Technical University of Denmark, Denmark. October 2012
- [39] .Kragh,J.B. Laustsen, S.Svedensen. **Proposal for Energy Rating System of Windows in EU**. DTU Scientific-Report, Department of Civil Engineering, 2008.
- [40] EN 13779. **Ventilation for non-residential building-Performance requirements for ventilation and room conditioning system**.
- [41] A.Blomsterberg. **Availability of components for very low energy residential buildings on the North European Building Market**. North Pass, Lund University 7.5.2011
- [42] ANSI/ASHRAE Standard 55-2010,**Thermal Environmental Conditions for Human Occupancy**
- [43] http://eic.velux.com/eic_visualizer/about/validation.aspx)
- [44] prEN 15203/15315:2006. **Energy performance of buildings.Overall energy use, CO2 emissions and definition of energy ratings**
- [45] EN 15251:2006.**Indoor environmental input parameters for design and assessment of energy performance of buildings-addressing indoor quality, thermal environment, lighting and acoustics**.
- [46] M. C. Peel, B. L. Finlayson, T.A. McMahon. **Update world map of the Koppen-Geiger climate classification**.Hydrology and Earth System Sciences,11, 1633-1644, 2007 (<http://www.hydrol-earth-syst-sci.net/11/1633/2007/hess-11-1633-2007>)
- [47] S.Herkel, J.Pfafferoth,U. Knapp. **A preliminary model of user behavior regarding the manual control of windows in office building**. Fraunhofer Institute for Solar Energy System ISE (Article submitted for 8th REHVA World Congress Clima 2005 Lausanne).
- [48] BR 10. **Building Regulation**. The Danish Ministry of Economic and Business Affairs Danish enterprise and Construction Authority. Copenhagen 12 of December 2010
- [49] CIBSE. **Climatic change and the indoor environment: impacts and adaptation**.TM 46 , The chartered institution of Building Service Engineers (CIBSE), London, UK.

11. APPENDIX A

In Figure 104 the wind velocity (on the left) and the wind frequency (on the right) are shown for Copenhagen location. For every main direction a mean value of the velocity and frequency, calculated as direction-averaged, is presented on a monthly base. The higher value on the axis, the greater is the wind velocity, or frequency, of the wind blowing from that direction.

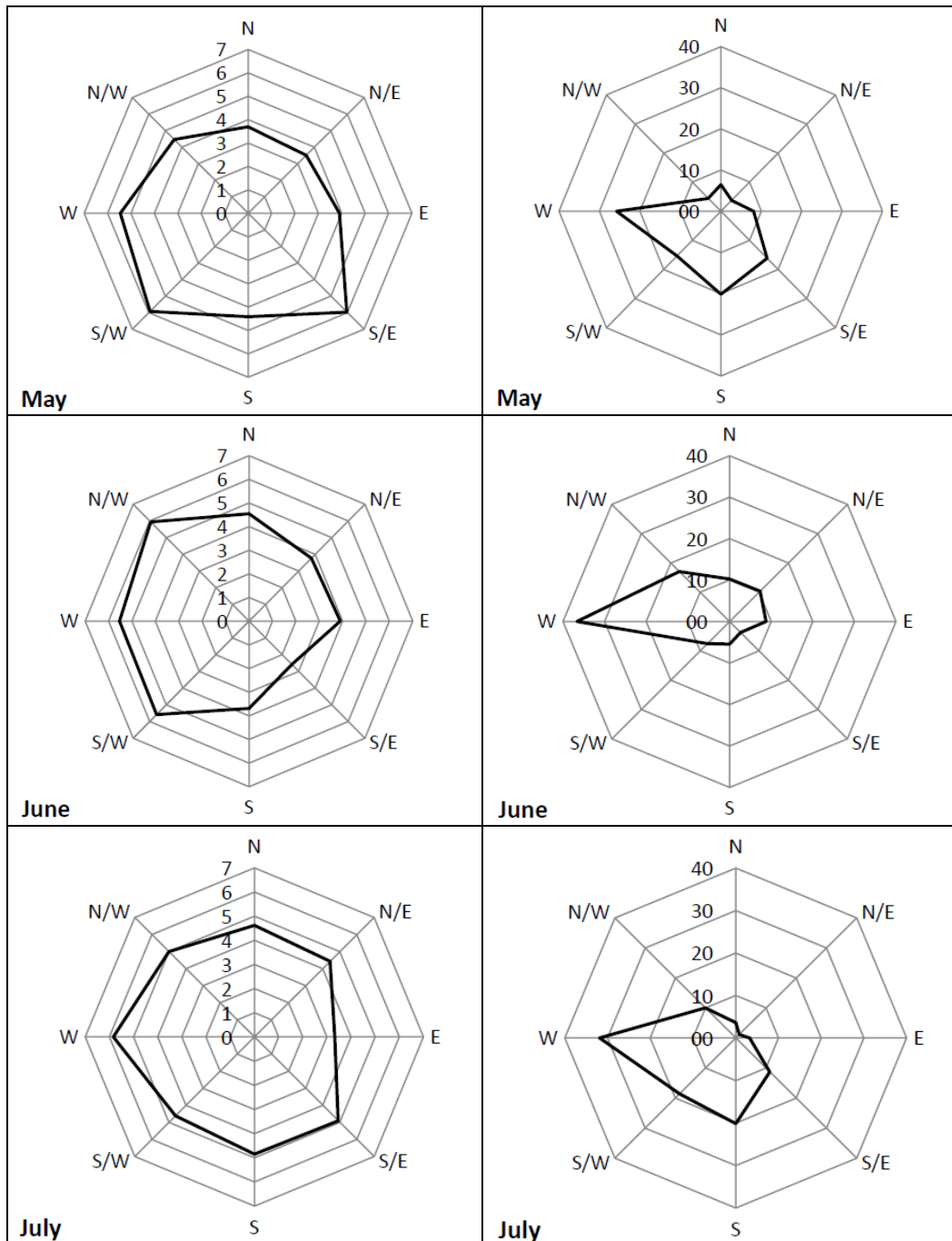

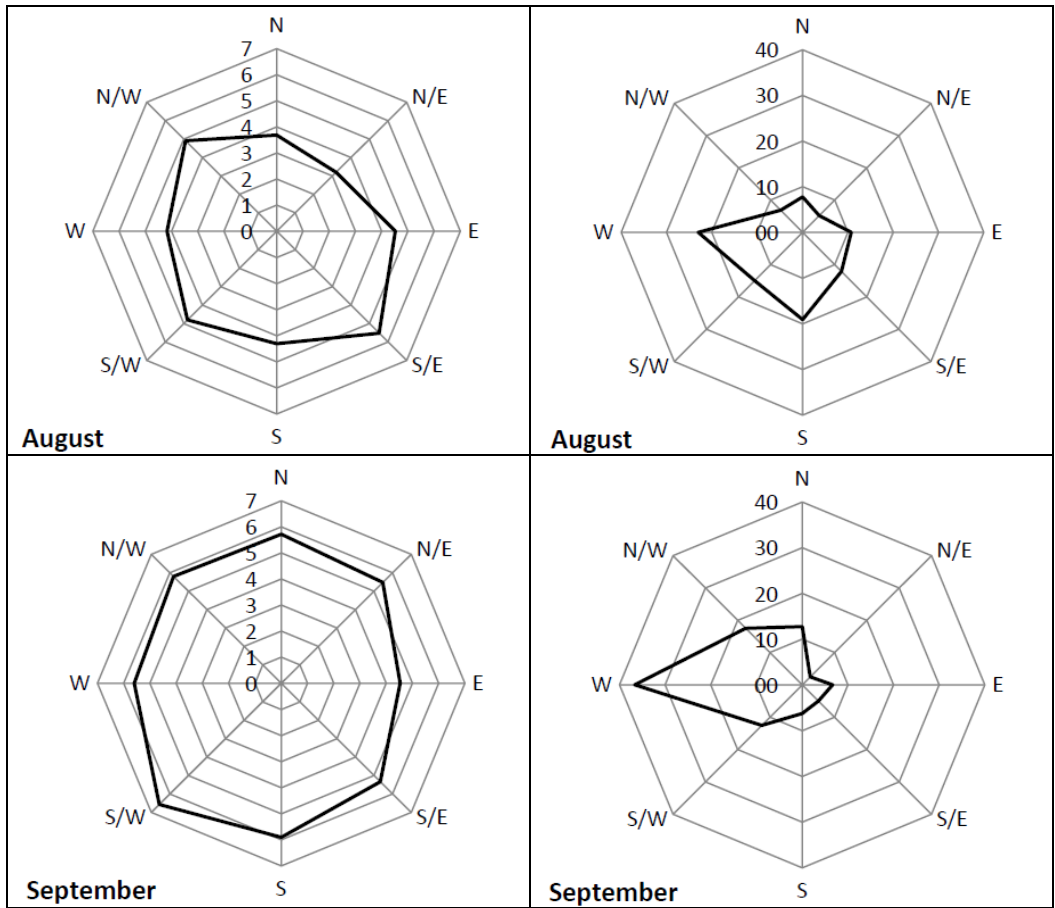
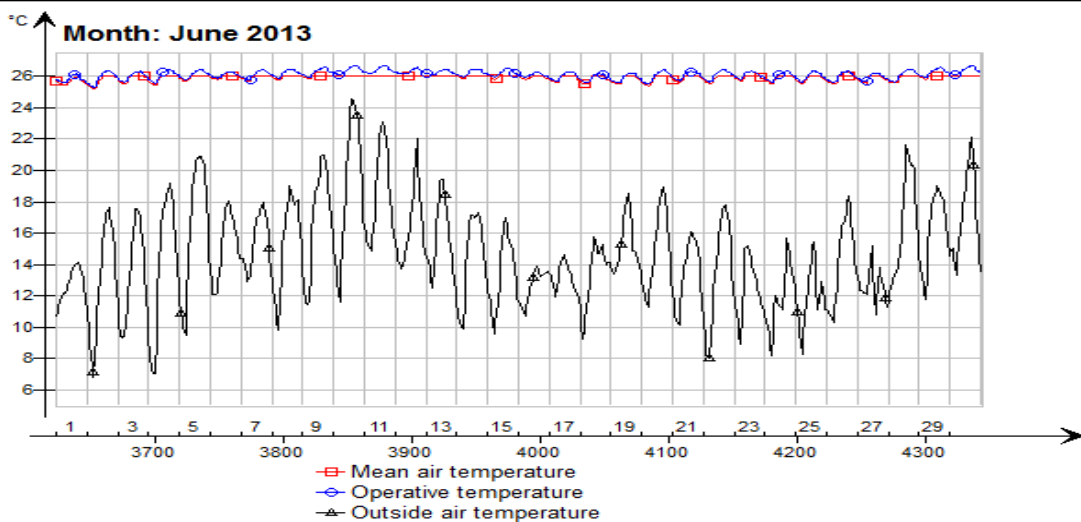
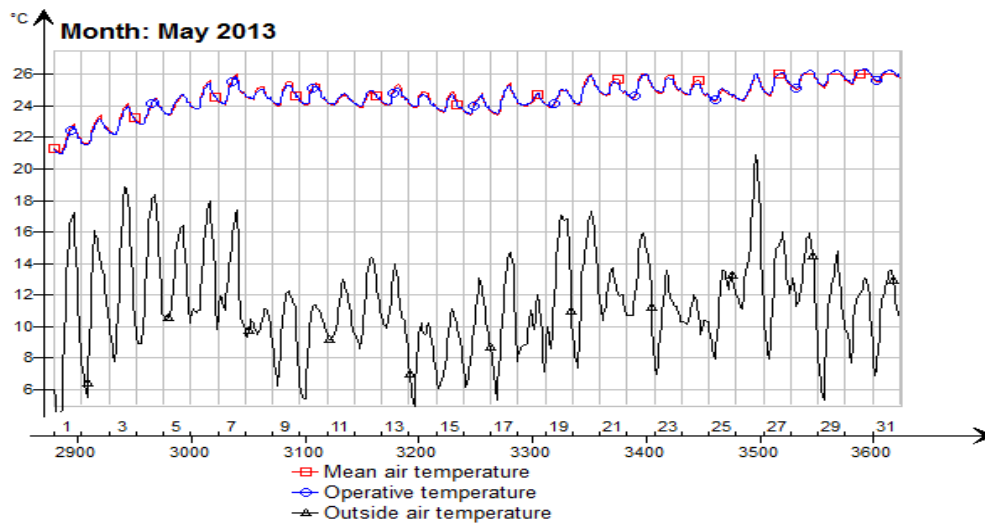

Figure 104 Wind velocity (left) and wind frequency (right) for the city of Copenhagen during the night ventilation period

12. APPENDIX B

In this appendix some graphs about temperature monthly trends are collected.

In particular in Figure 105 the trends of indoor air, operative and outside air temperatures of M_HC model during May, June, July, August and September. These graphs are collected to show how the increased level of insulation brings to overheating and discomfort. Especially during transition months (May and September) the temperature inside are really high above all considering the lower outside air temperature.



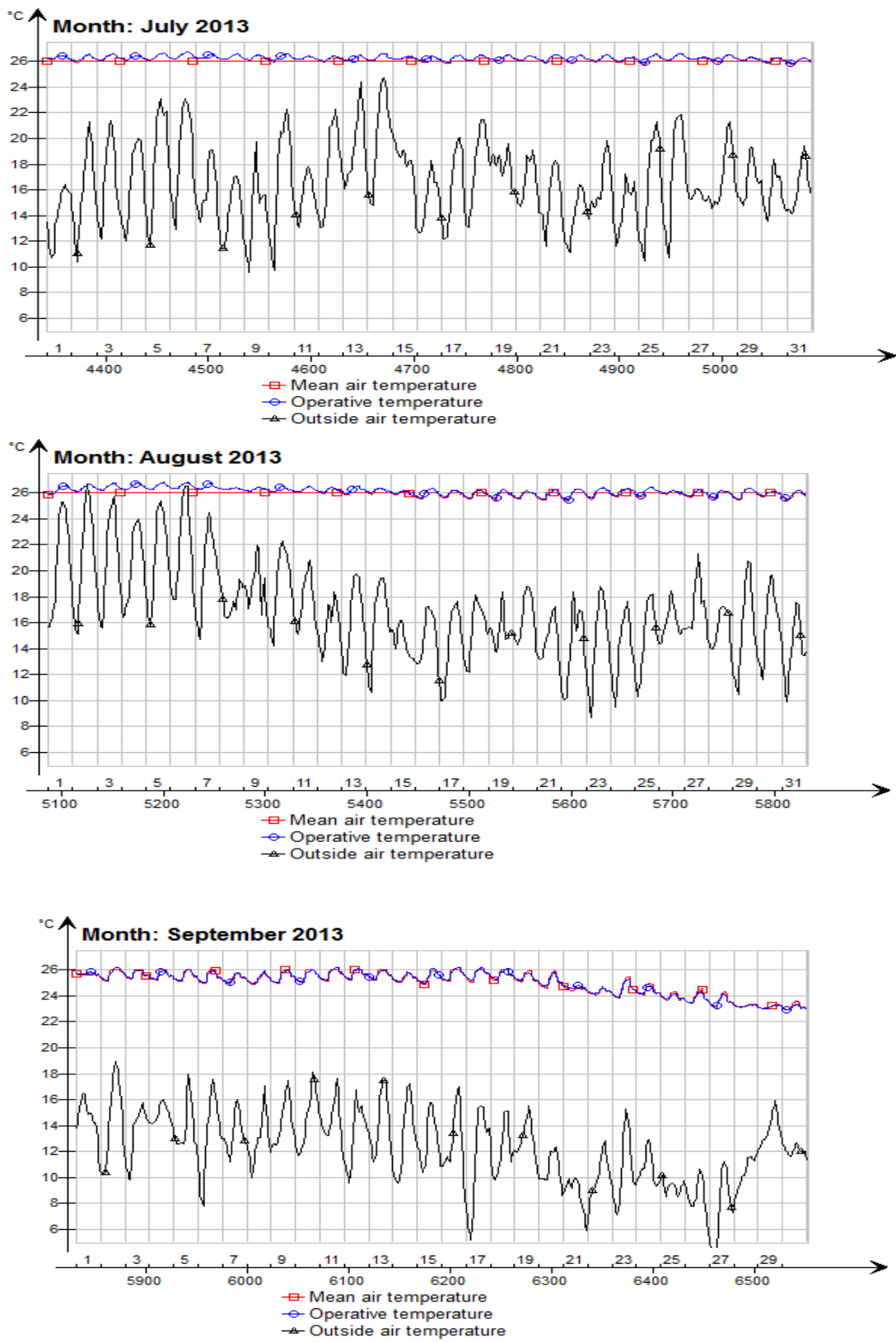
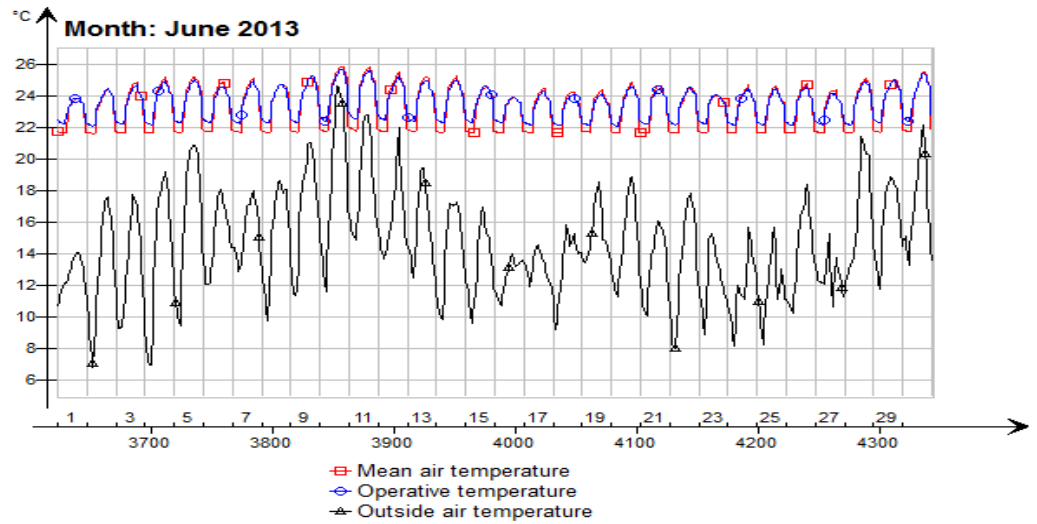
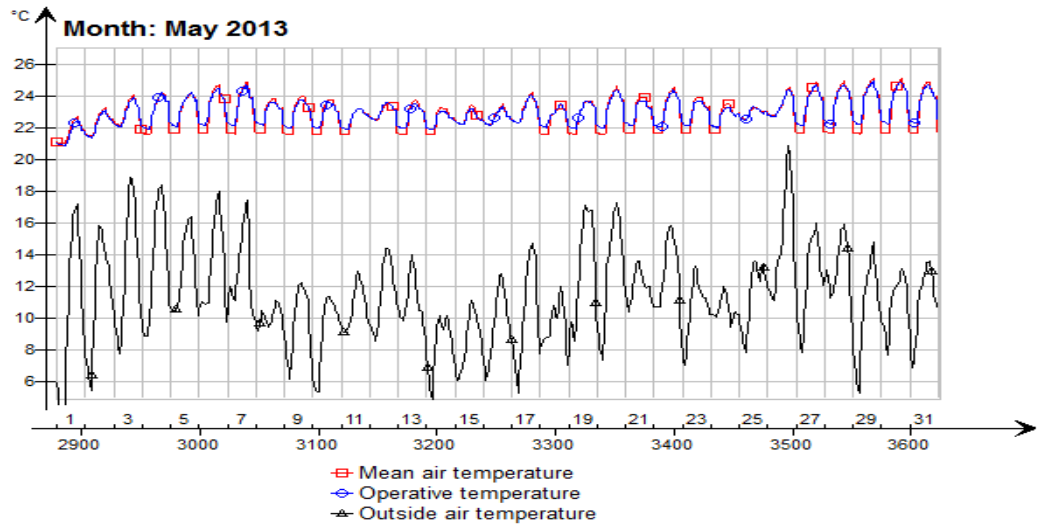

Figure 105 Monthly temperatures tend for M_HC model by using the increased insulated envelope.

Figure 106 shows the monthly temperatures trends for M_HC_Na model. It is clearly visible how the windows opening during night has the effect of lowering the temperatures reducing the peak of the day after.



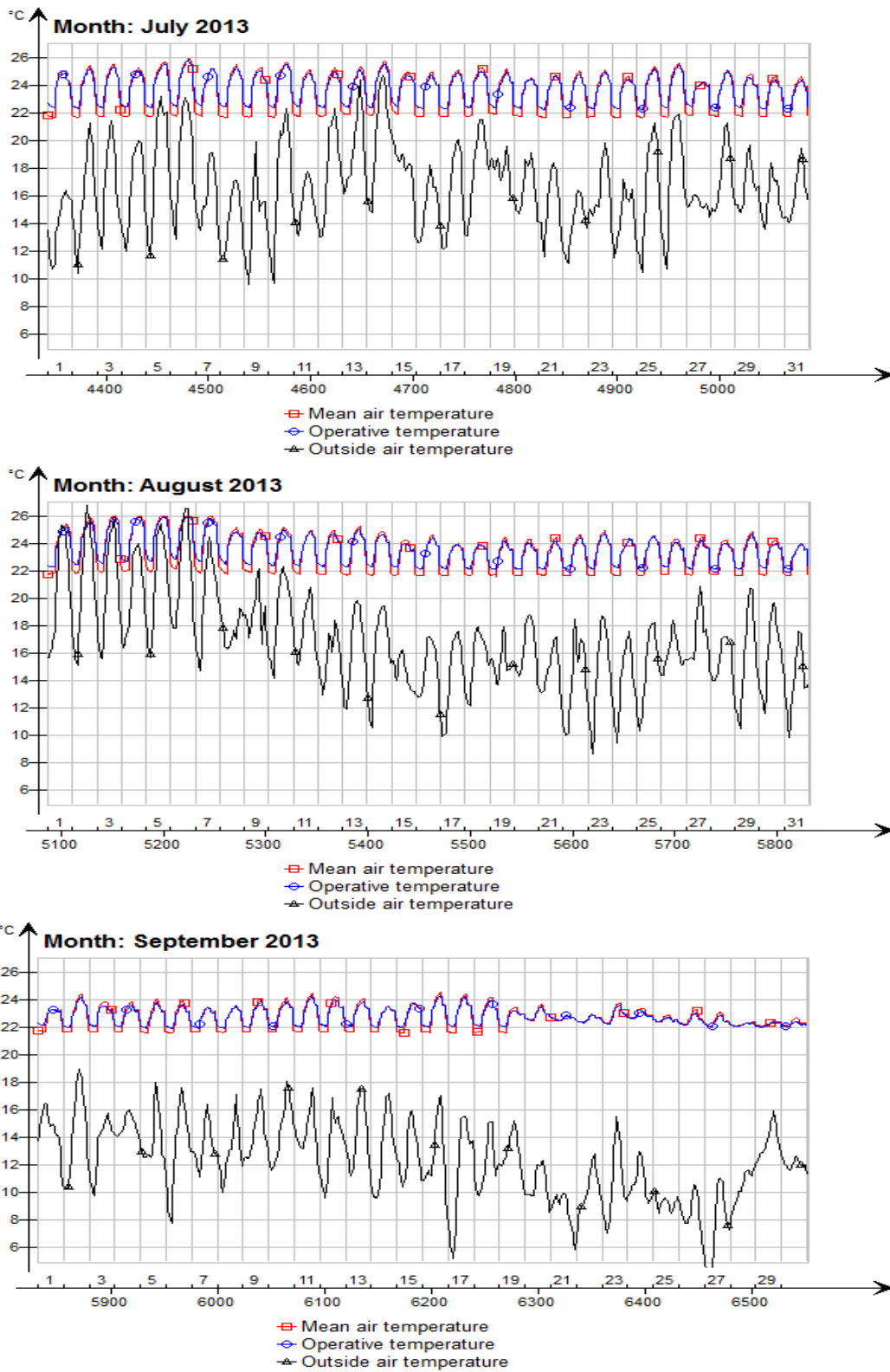

Figure 106 Monthly temperatures tend for M_HC_Na model by using the increased insulated envelope.

APPENDIX C

In this appendix the detailed energy demand comparison between the two structures is done

Table 32 Heating energy demand

Case studies	STRUCTURE A [kWh/m ² /year]	STRUCTURE B [kWh/m ² /year]
M_HC	57.7	17.9
M_HC_HRV	57.8	18.0
M_HC_S	59.2	18.0
M_HC_S_HRV	59.2	18.0
M_HC_Na	58.1	18.0
M_HC_Na_HRV	58.1	18.1
M_HC_SNa	59.3	18.0
M_HC_SNa_HRV	59.3	18.0

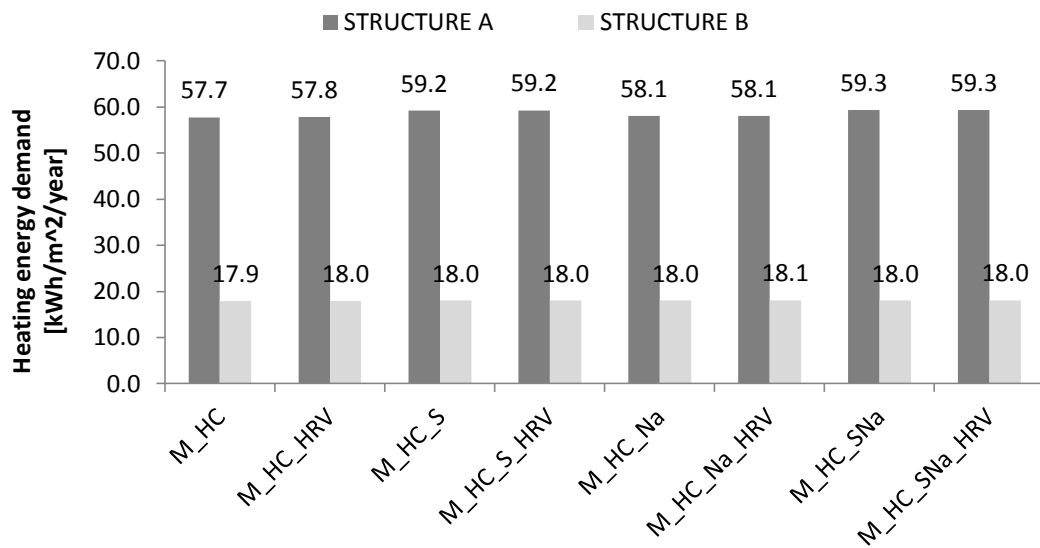
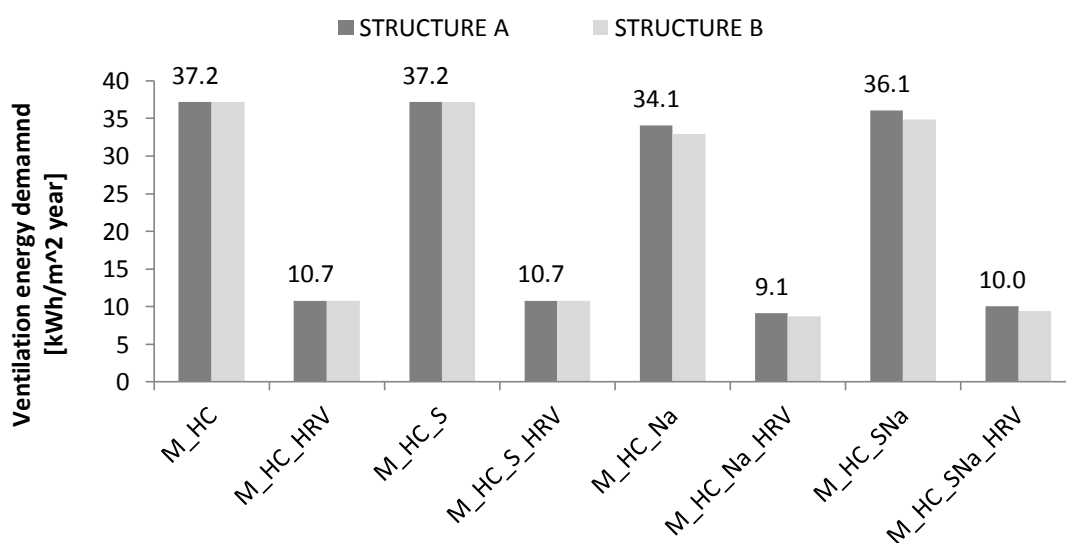

Figure 107 Heating energy demand

Table 33 Ventilation energy demand

Case studies	STRUCTURE A [kWh/m ² year]	STRUCTURE B [kWh/m ² year]
M_HC	37.2	37.2
M_HC_HRV	10.7	10.8
M_HC_S	37.2	37.2
M_HC_S_HRV	10.7	10.7
M_HC_Na	34.1	32.9
M_HC_Na_HRV	9.1	8.7
M_HC_SNa	36.1	34.9
M_HC_SNa_HRV	10.0	9.4

**Figure 108** Ventilation energy demand**Table 34** Cooling energy demand

Case studies	STRUCTURE A [kWh/m ² /year]	STRUCTURE B [kWh/m ² /year]
M_HC	13.3	21.4
M_HC_HRV	13.4	21.4
M_HC_S	0.6	0.4
M_HC_S_HRV	0.6	0.4
M_HC_Na	7.1	0.1
M_HC_Na_HRV	7.1	0.1
M_HC_SNa	0.2	0.0
M_HC_SNa_HRV	0.2	0.0

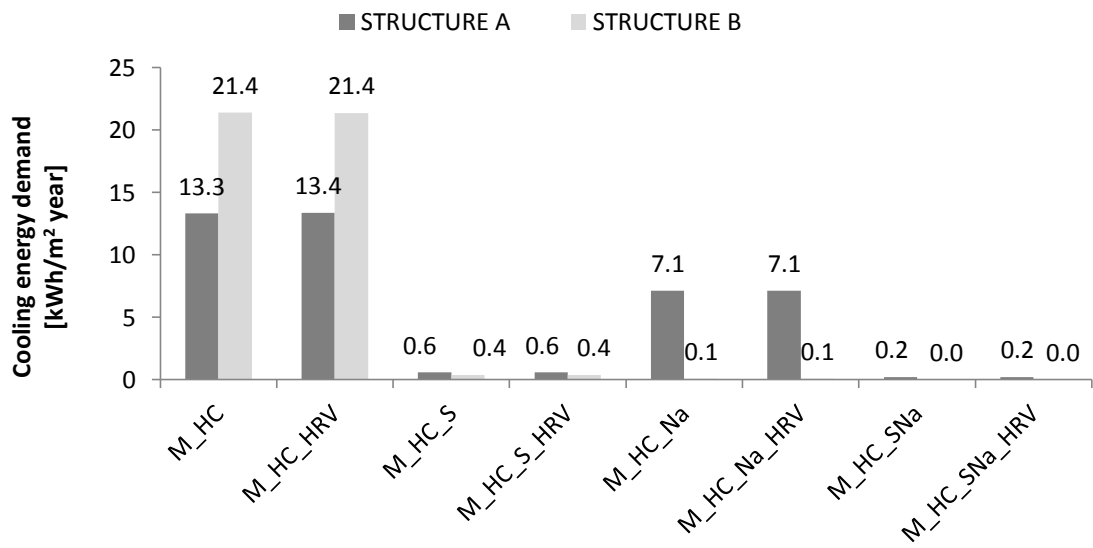

Figure 109 Cooling energy demand

APPENDIX D

The first idea to design the variable air volume system was to set the maximum fan air flow as the equivalent value of natural one flushed through the windows during night.

2600 l/s (18 ach) air flow value has been found with NNV Though hypothetically this value should be used as threshold for the variable air volume system, different values were tested considering the effect on fan's energy demand The tested values are:

- 240 l/s;
- 350 l/s;
- 1400 l/s.

Figure 110, Figure 111 and Figure 112 collect the results in term of the average values of air change per hour during day and night, total energy demand and annual thermal comfort.

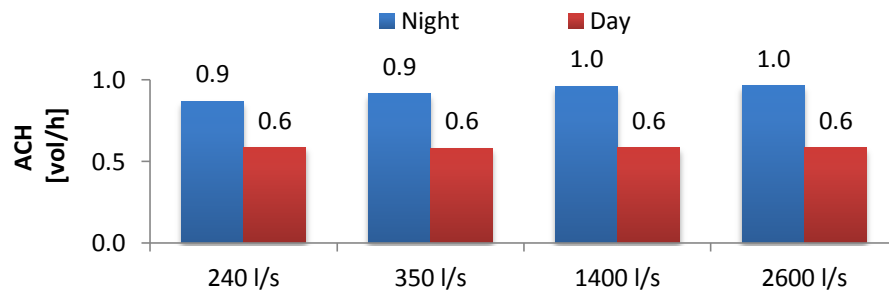

Figure 110 Daytime and nighttime average ACH values

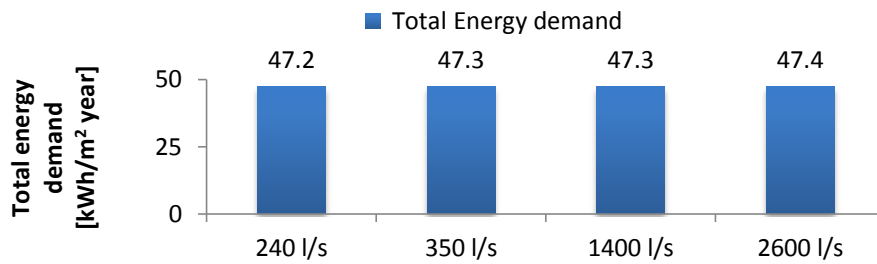

Figure 111 Total energy demand for different maximum air flow

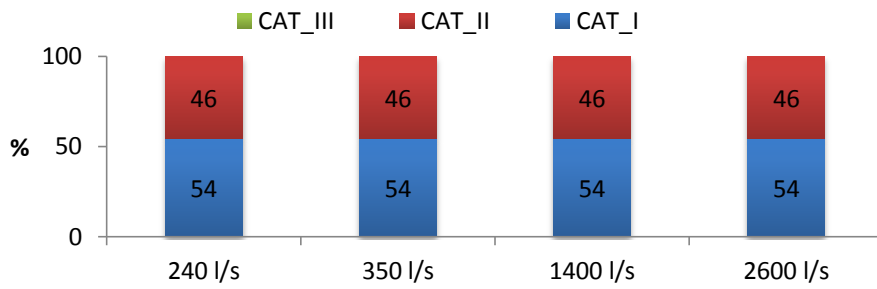
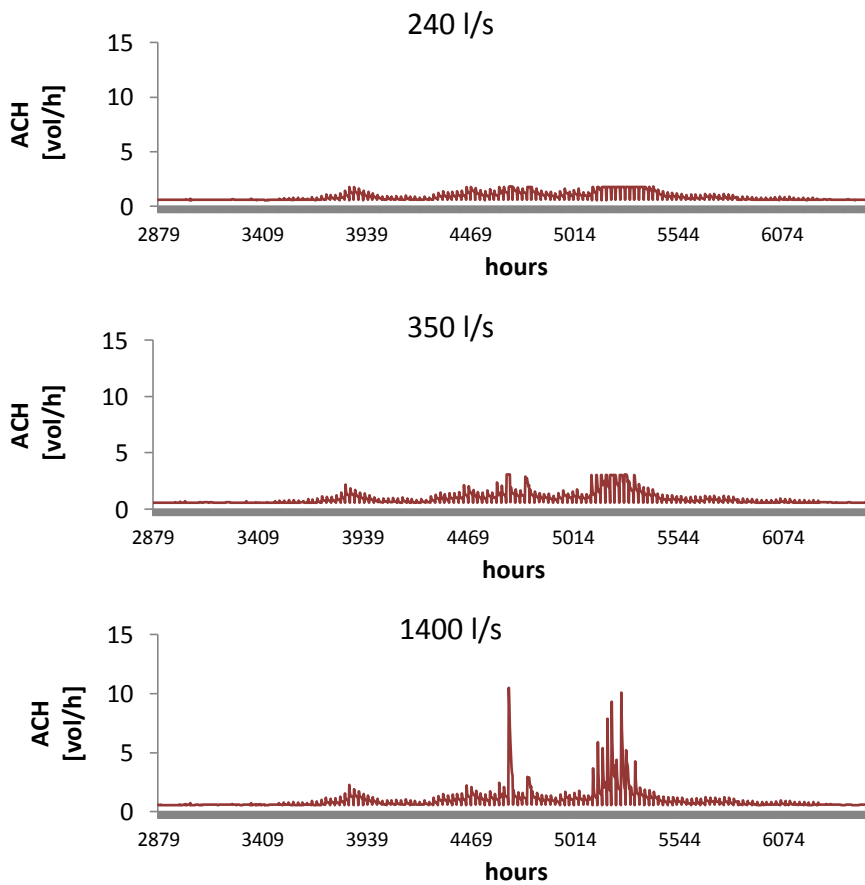

Figure 112 Annual thermal comfort categories for different maximum air flow

In spite of such different values, total energy demand and thermal comfort are quite the same. What slightly differs is the average value of ach during night: it is 0.9 ach for the first two values tested (140 and 350 l/s) while is 1 ach for the last two (1400 and 2600 l/s)¹⁵. The reason of this almost constant total energy demand can be found in Figure 113 where the tendencies of the nighttime ach during the considered period (between May 1th and September 30th) are collected.



¹⁵ It worth to remember that for air change rate calculation both mechanical inflow and infiltration are considered.

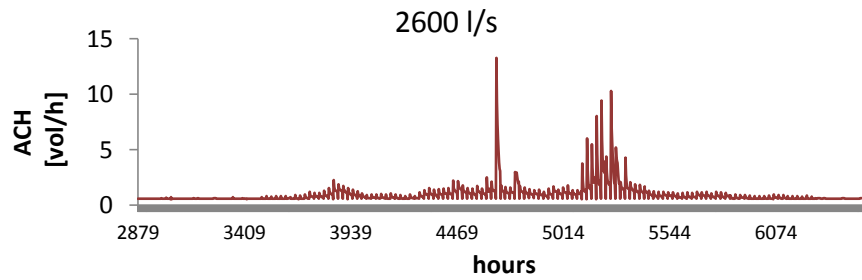

Figure 113 ACH nighttime tendencies (between May 1th and September 30th) different maximum air flow

Very high values of ach during nighttime are reached only few times during the considered period and it is for this reason that the energy demanded to the fan is not so different between the cases. Table 35 presents the maximum, minimum and average value of ach reached during night.

Table 35 Nighttime ACH: maximum, minimum and average

Ach [vol/h]	240 l/s	350 l/s	1400 l/s	2600 l/s
MAX	1.8	3.1	10.5	13.3
MIN	0.6	0.6	0.6	0.6
AVERAGE	0.9	0.9	1	1

Considering that total energy demand is just slightly increased (only 0.42%¹⁶) and that the thermal comfort is equal in any case, the value of 2600 l/s has been chosen as threshold for the variable air volume system.

Nevertheless, so far, the analysis have been done without keeping in mind that, in reality, an air handling unit design starts from maximum ACH value. To design a residential air handling unit with such high maximum value is rationally impossible for two simple reasons: the first one is that ducts size will not be compatible with the available and the second one, still related with the ducts size, is that greater the ducts are, more material is necessary causing a total cost increase. This last consideration rises in importance if for example the air handling unit is used only for the ventilation. After this implication, it has been chosen to set limit to the maximum air change rate during night equal to 1 ach that correspond to 141.3 l/s maximum air flow.

Actually two different maximum ach value has been tested: 1.5 and 1. In Figure 114 and 115 the comparison in term of total energy demand and thermal comfort. It worth to remember that the total air change rate considered in this two graph is the total one that takes into account both mechanical inflow and infiltration. For this reason, even if the maximum air flow supply by the fan can equivalent to 1 ach, the total building ach is 1.1 because of the infiltration and leakage.

¹⁶ If referred to the Energy demand of 240 l/s case

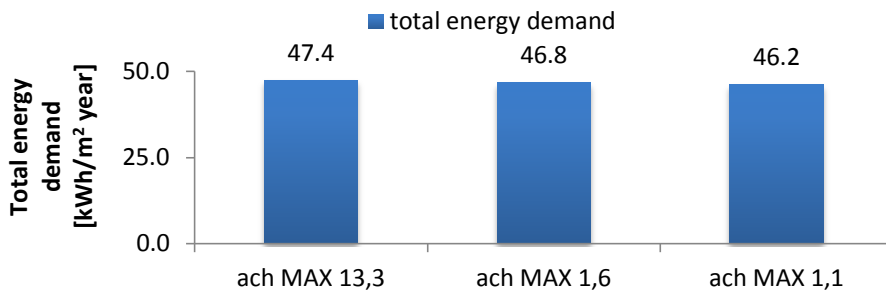

Figure 114 Total energy demand for different maximum ACH

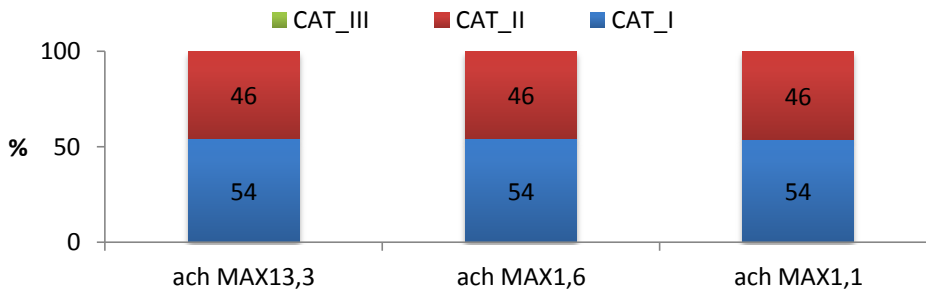
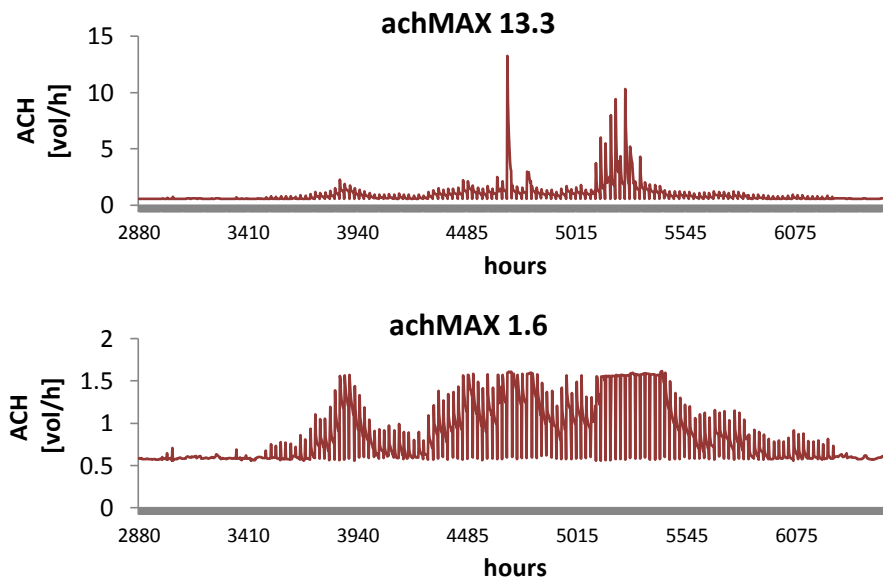

Figure 115 Thermal comfort categories for all the year according to EN 15251

In Figure 116 the air change rates trends during the application period are shown.



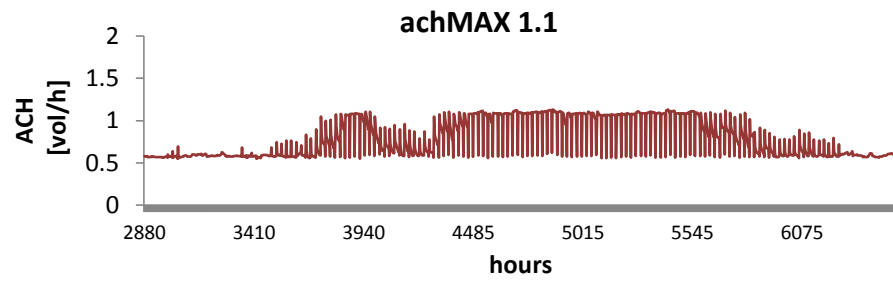

Figure 116 Air change rate graphs

APPENDIX E

In this appendix the temperature trend for the two different methodologies are showed. Figure 117 shows the annual temperature profiles while in Figure 118 the monthly ones (from May to September) are collected. In Figure 119 the operative temperatures trends for the warmest summer week are presented.

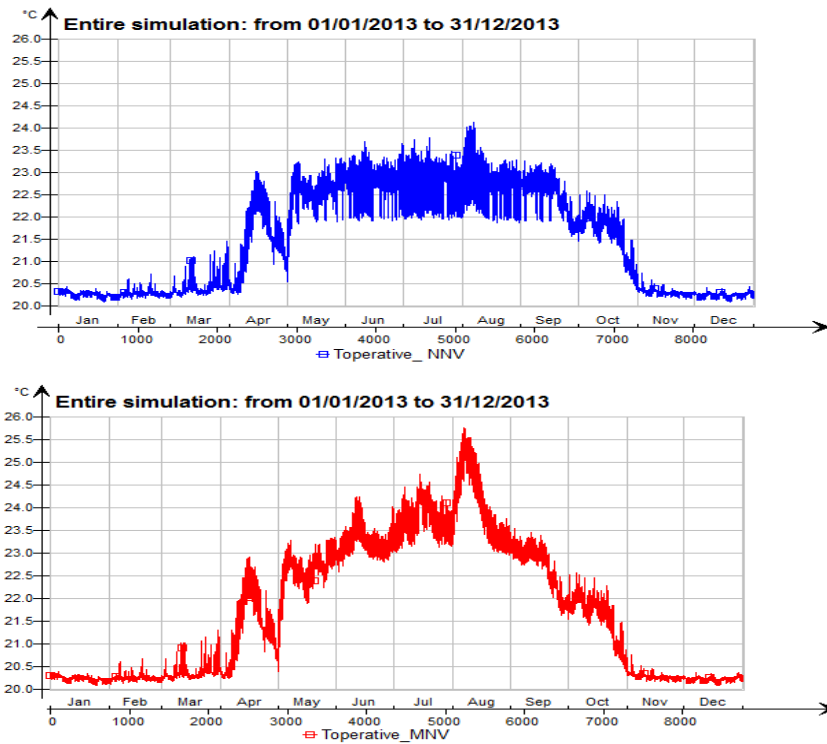
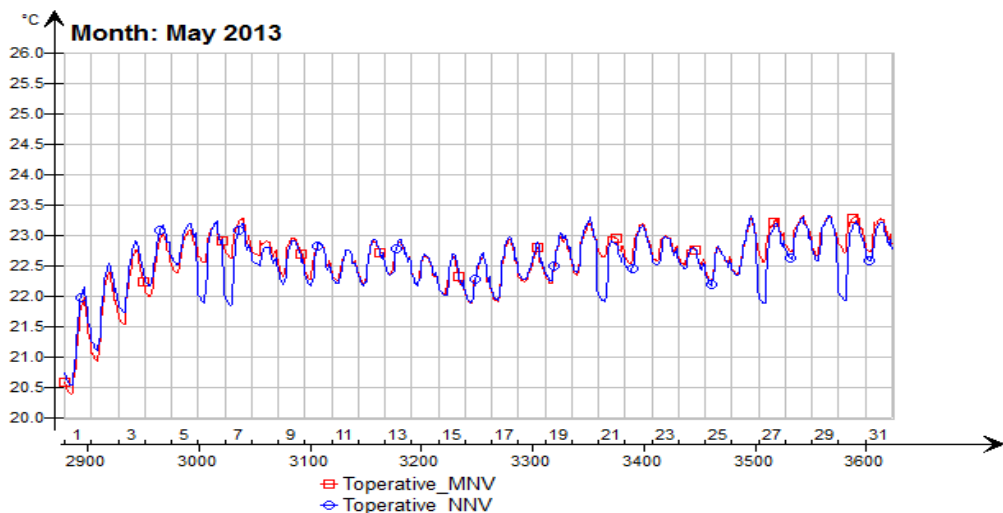
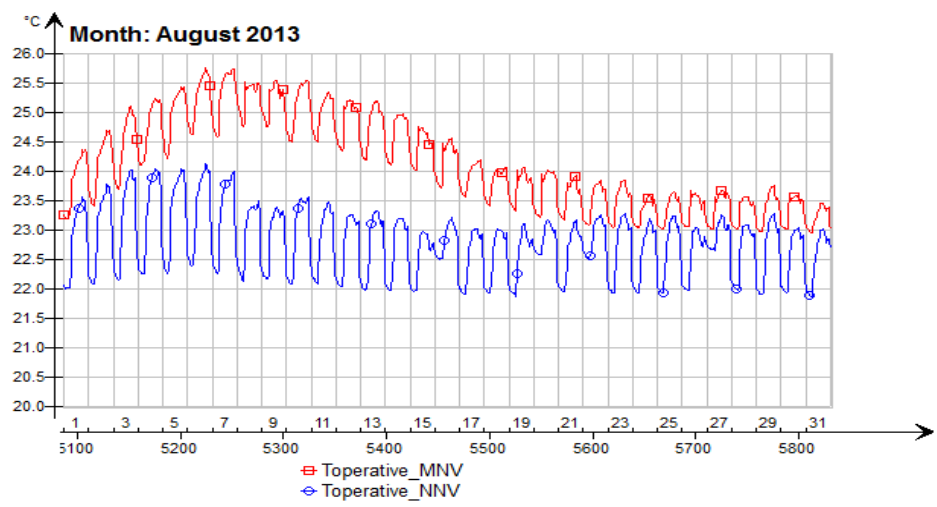
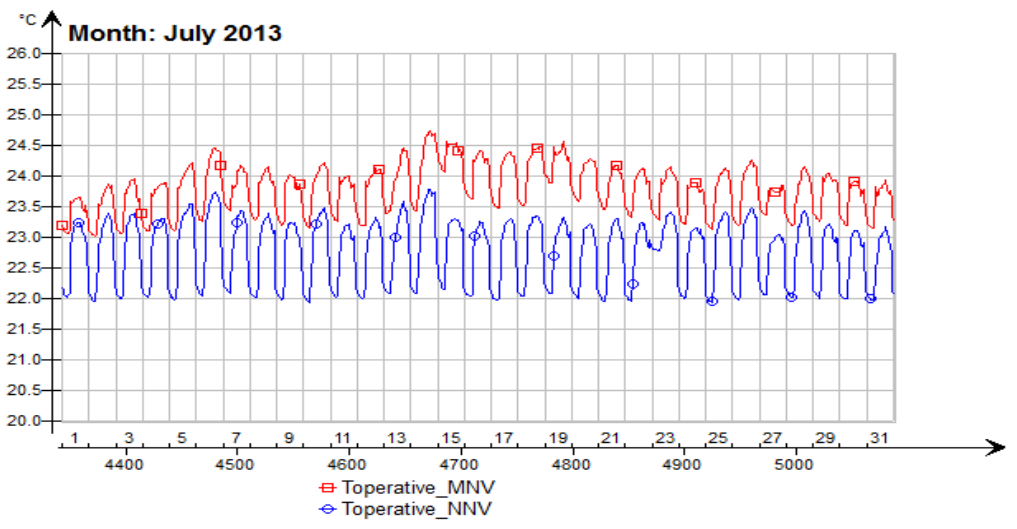
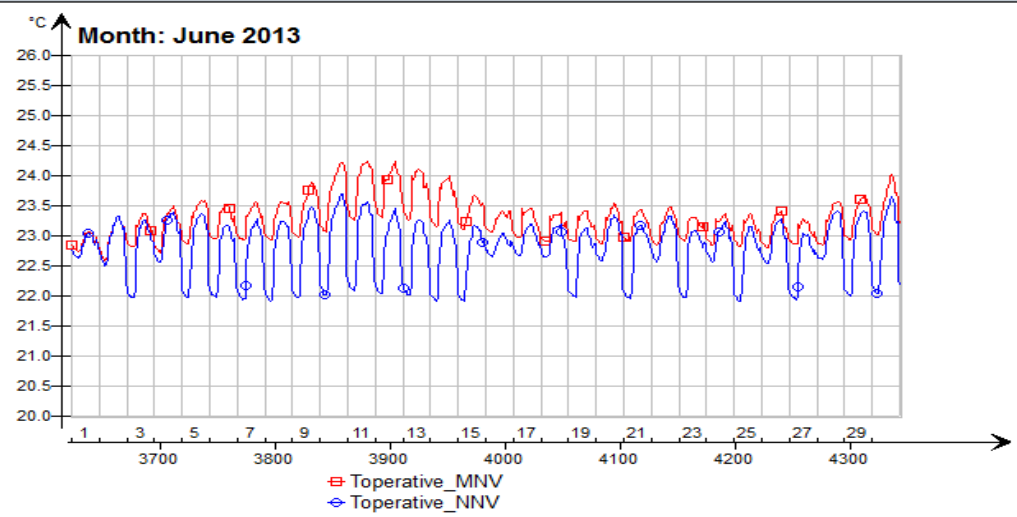

Figure 117 Annual operative temperature trends for MNV (upper) and for NNV (lower).





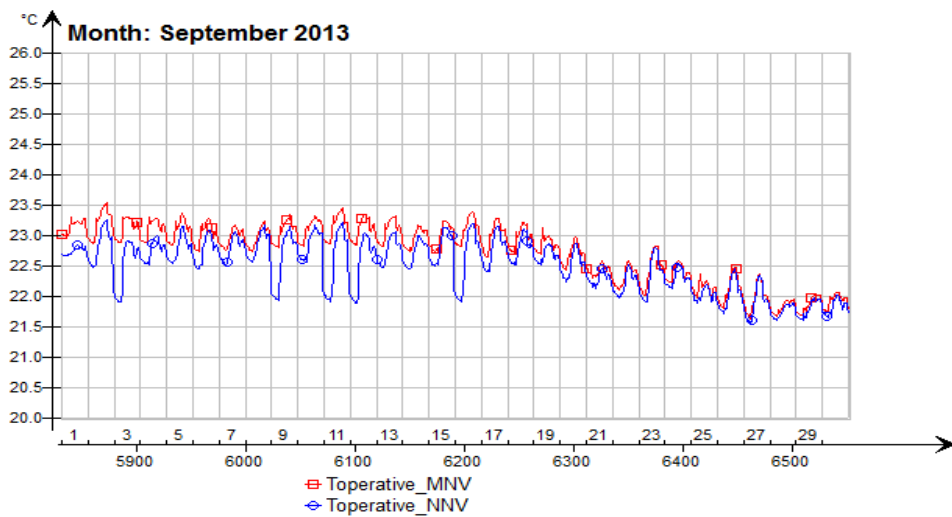

Figure 118 Monthly operative temperature trends.

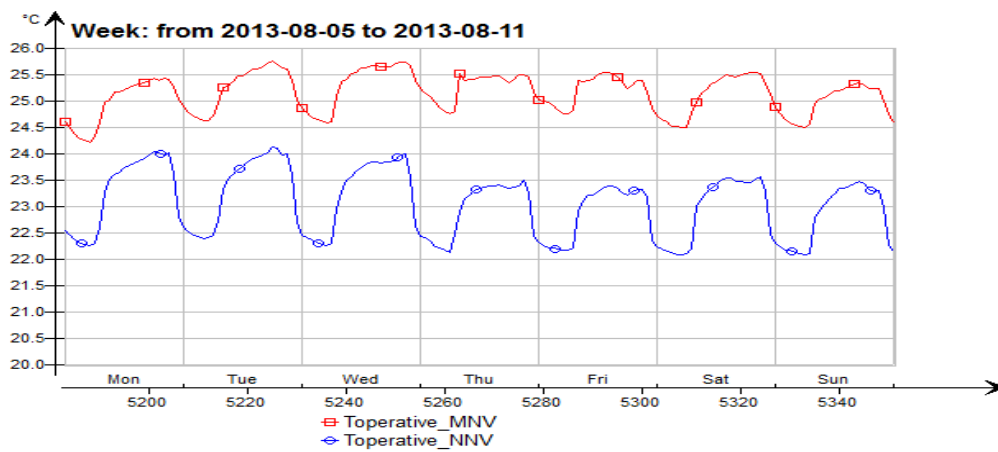

Figure 119 Operative temperature trends from August 5th to August 11th

In Figure 120 and Table 36 respectively, the time percentage in which windows are opened with different ranges and the percentage of hours in which are opened over the total period night ventilation.

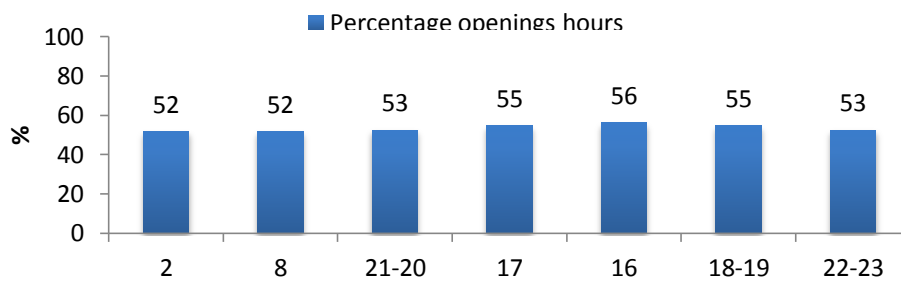

Figure 120 Percentage working hours

Table 36 Windows opening ranges during night for NNV model

Windows number	0-4 cm [%]	4-8 cm [%]	8-12 cm [%]	12-16cm [%]	16-20cm [%]	20-24cm [%]	24-28cm [%]
2	69	14	2	2	0	12	0
8	69	14	2	2	0	12	0
21-20	68	15	3	2	1	12	0
17	62	18	5	2	1	1	12
16	0	49	35	3	1	1	11
18-19	62	18	5	2	1	1	12
22-23	68	15	3	2	1	12	0

APPENDIX F

In this appendix some data about the shading and daylight analysis, dealt with in paragraph 7.1, are reported.

Figure 121 shows the monthly values of daylight, ventilation demand and artificial lighting for both methodologies of night ventilation with different solar shading set-point. The same values are listed, separately per each model, in Table 37 and 38.

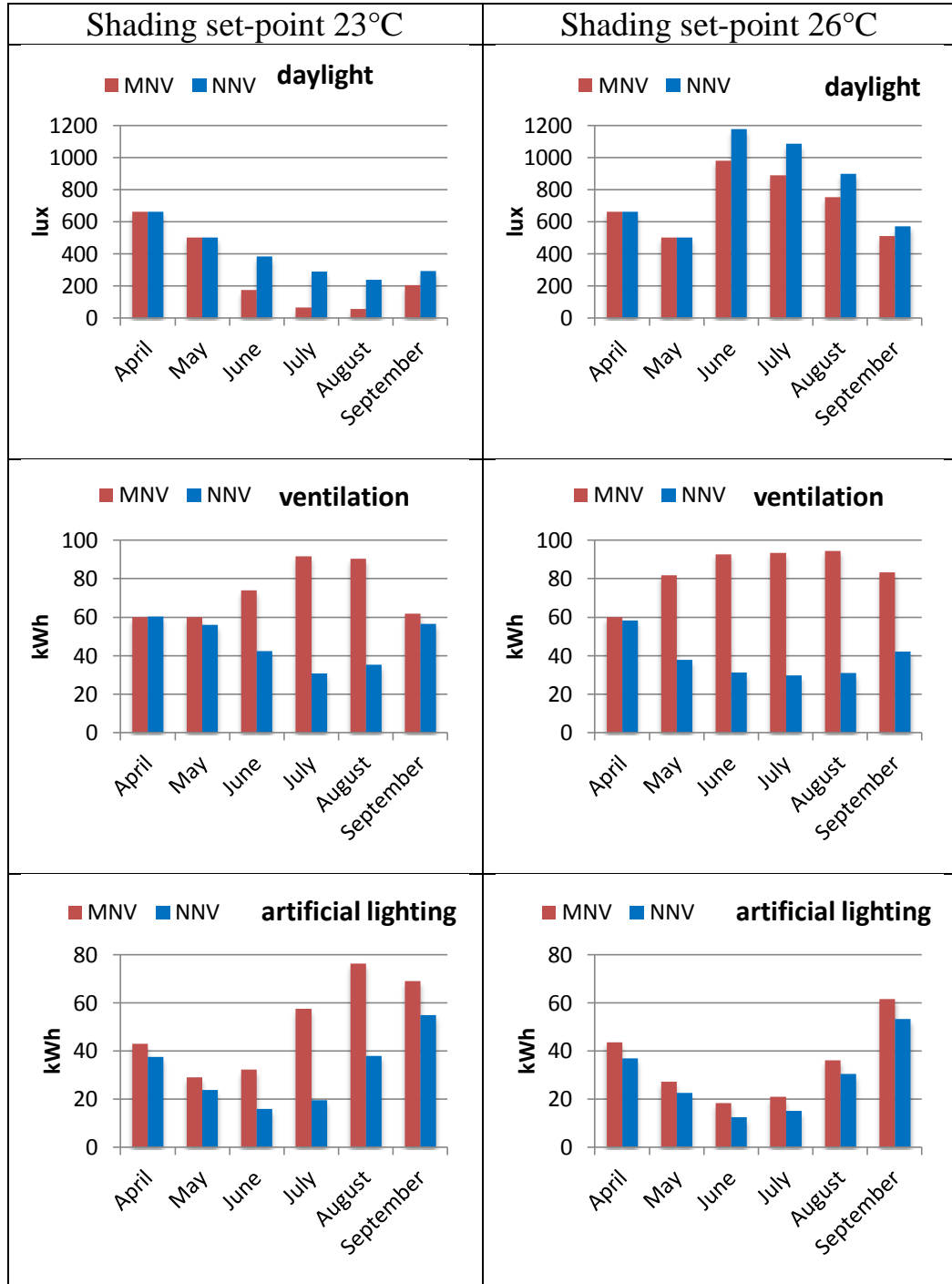

Figure 121 Monthly daylight, ventilation demand and artificial lighting values for two different solar

Table 37 MNV model's monthly values of daylight, cooling and ventilation demand and artificial lighting.

	DAYLIGHTING [lux]		COOLING [kWh]		VENTILATION [kWh]		ARTIFICIAL LIGHTING [kWh]	
	23°C	26°C	23°C	26°C	23°C	26°C	23°C	26°C
April	662	662	0	0.0	60.0	60.0	43.0	43.5
May	502	502	0	5.7	59.9	81.8	29.1	27.2
June	174	980	0	145.0	74.0	92.6	32.2	18.4
July	65	890	0	305.9	91.6	93.2	57.4	20.9
August	58	753	0	314.9	90.2	94.3	76.3	36.1
Sept	205	512	0	4.8	61.9	83.2	69.0	61.6

Table 38 NNV model's monthly values of daylight, cooling and ventilation demand and artificial lighting.

	DAYLIGHTING [lux]		COOLING [kWh]		VENTILATION [kWh]		ARTIFICIAL LIGHTING [kWh]	
	23°C	26°C	23°C	26°C	23°C	26°C	23°C	26°C
April	662	662	0	0	60	58	37.5	36.9
May	502	502	0	0	56	38	23.7	22.6
June	384	1177	0	1.6	42	31	15.9	12.4
July	290	1086	0	2.2	31	30	19.6	15.2
August	58	900	0	20.5	35	31	38	30.4
Sept	292	573	0	0	57	42	54.8	53.3

From all the monthly values an average value has been calculated; the compared results are shown in Figure 122.

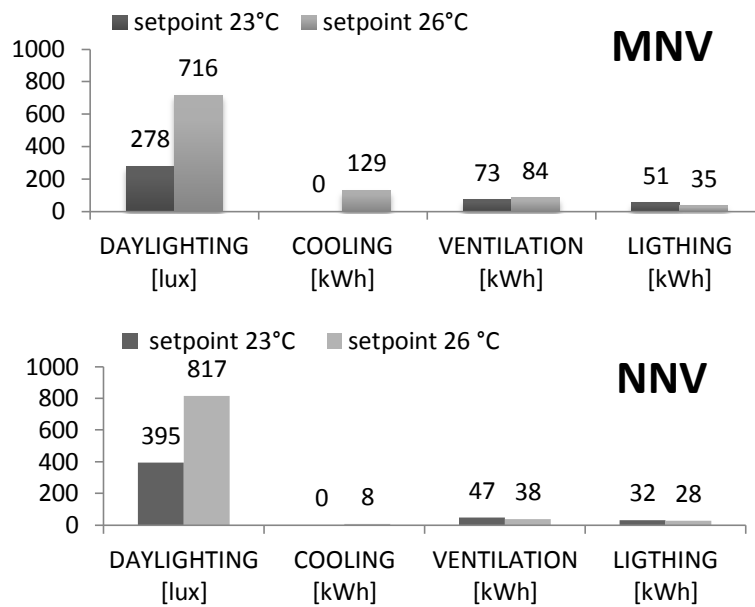

Figure 122 Comparison of average values for two different solar shading set-points.

Figure 123 shows the shading operation for the two models: MNV (red profile) and NNV (blu profile) when the set-point is 26°C. It is clearly visible how the solar shading works more times when the building is cooled down mechanically even if the glazed area covered is really small. The output, indeed, is just 0.1; this means that, when the shading is on, maximum 10% of the windows area will be covered.

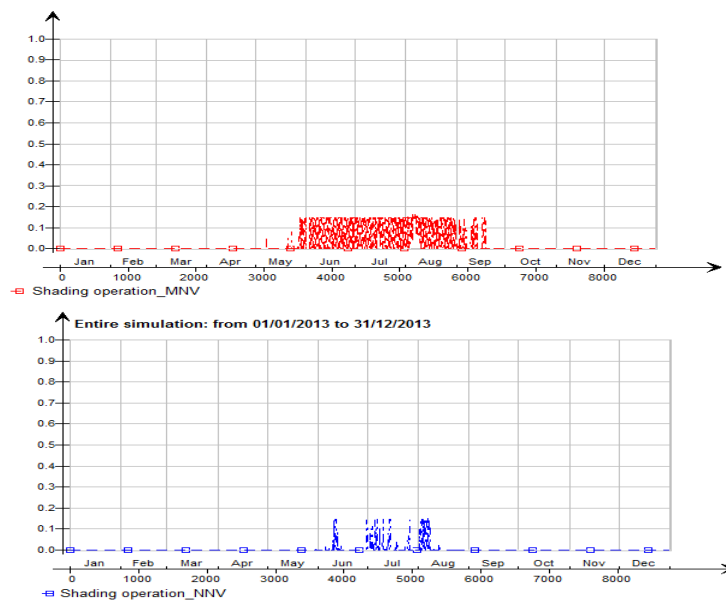

Figure 123 Shading operation when set-point 26°C: MNV (upper) and NNV (lower)

APPENDIX G

This appendix collects all the data referring to the windows opening during daytime (paragraph 7.6.1)

Table 39 NNV model: percentage of opening windows range at 7 a.m.

Windows number	0-4 cm [%]	4-8 cm [%]	8-12 cm [%]	12-16 cm [%]	16-20 cm [%]	20-24 cm [%]	24-28 cm [%]
20_21	70	30	0	0	0	0	0
9_10	63	35	2	0	0	0	0
14	69	31	0	0	0	0	0
18_19	55	43	2	0	0	0	0

Table 40 NNV model: percentage of opening windows range at 5 p.m.

Windows number	0-4 cm [%]	4-8 cm [%]	8-12 cm [%]	12-16 cm [%]	16-20 cm [%]	20-24 cm [%]	24-28 cm [%]
20_21	13	19	21	27	16	5	0
9_10	13	15	20	26	19	7	0
14	13	20	21	27	14	4	0
18_19	13	9	19	15	20	16	7

Table 41 MNV model: percentage of opening windows range at 7 a.m.

Windows number	0-4 cm [%]	4-8 cm [%]	8-12 cm [%]	12-16 cm [%]	16-20 cm [%]	20-24 cm [%]	24-28 cm [%]
20_21	15	43	26	4	4	8	0
9_10	14	38	32	4	4	10	0
14	16	44	23	5	3	8	0
18_19	12	26	34	13	3	4	9

Table 42 MNV model: percentage of opening windows range at 5 p.m.

Windows number	0-4 cm [%]	4-8 cm [%]	8-12 cm [%]	12-16 cm [%]	16-20 cm [%]	20-24 cm [%]	24-28 cm [%]
20_21	18	13	13	11	13	32	0
9_10	18	11	14	8	15	34	0
14	18	14	13	12	12	31	0
18_19	15	9	11	11	6	14	34

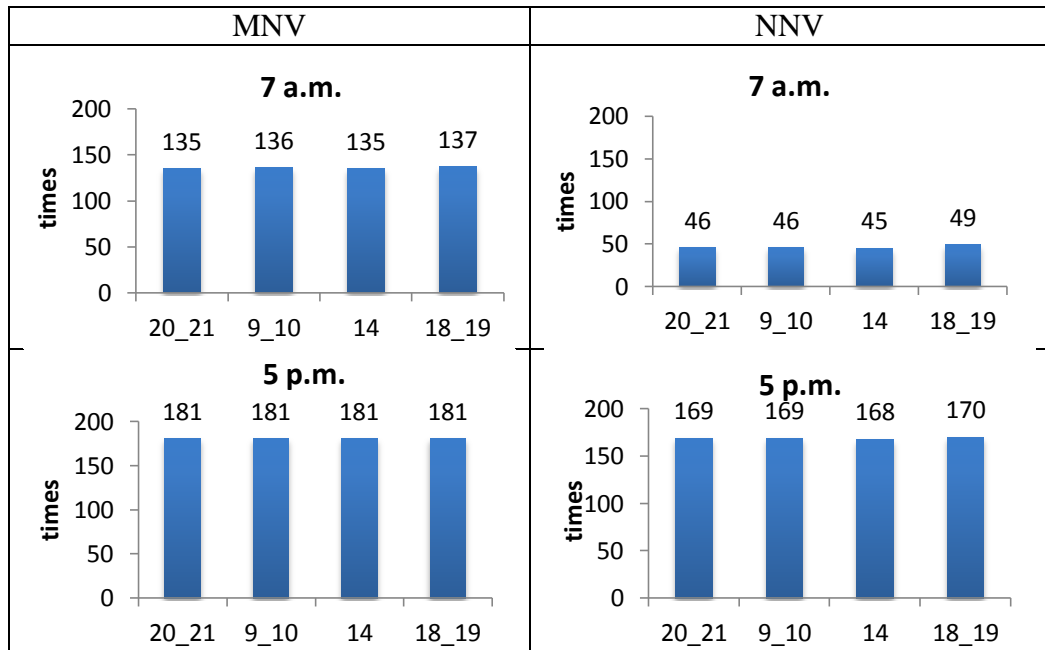

Figure 124 Number of hour in which the each windows is opened at 7a.m. and 5 p.m. for both models.

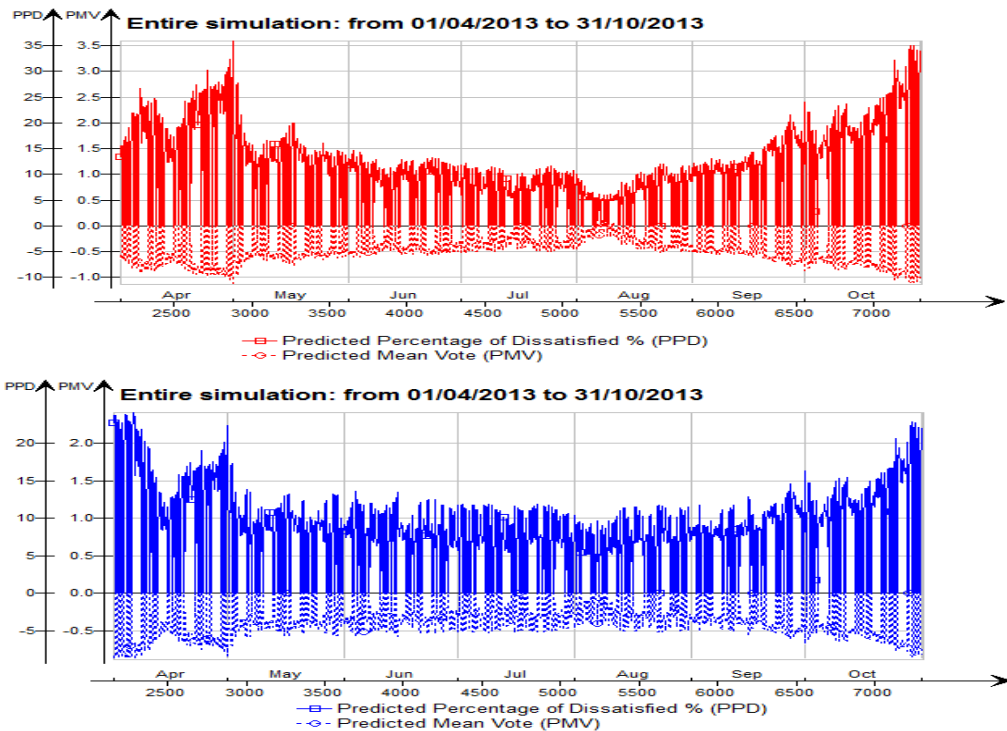

Figure 125 PMV and PPD trends between April and October for MNV model (upper) and for NNV model (lower).

In Figure 125 PMV and PPD trends are reported during the daytime ventilation period. The red graph refers to MNV while the blue one to NNV model. The graphs are directly screw dump from software output.