



**Calhoun: The NPS Institutional Archive**  
**DSpace Repository**

---

Faculty and Researchers

Faculty and Researchers' Publications

---

2001

# Inertial and Magnetic Posture Tracking for Inserting Humans Into Networked Virtual Environments

Bachmann, Eric R.; McGhee, Robert B.; Zyda, Michael J.;  
Yun, Xiaoping

---

Eric R. Bachmann, Robert B. McGhee, Xiaoping Yun, and Michael J. Zyda Inertial and Magnetic Posture Tracking for Inserting Humans Into Networked Virtual Environments, Proceedings of ACM Symposium on Virtual Reality Software & Technology (VRST 2001), Banff, Alberta, Canada, 15 - 17 November 2001, pp.9-16.  
<http://hdl.handle.net/10945/41586>

---

This publication is a work of the U.S. Government as defined in Title 17, United States Code, Section 101. Copyright protection is not available for this work in the United States.

*Downloaded from NPS Archive: Calhoun*



Calhoun is the Naval Postgraduate School's public access digital repository for research materials and institutional publications created by the NPS community. Calhoun is named for Professor of Mathematics Guy K. Calhoun, NPS's first appointed -- and published -- scholarly author.

**Dudley Knox Library / Naval Postgraduate School**  
**411 Dyer Road / 1 University Circle**  
**Monterey, California USA 93943**

<http://www.nps.edu/library>

# Inertial and Magnetic Posture Tracking for Inserting Humans Into Networked Virtual Environments

Eric R. Bachmann\*  
Department of Computer  
Science  
Miami University  
Oxford, Ohio 45056  
513.529.5950

bachmaer@muohio.edu

Robert B. McGhee\*  
Department of Computer  
Science  
Naval Postgraduate School  
Monterey, California 93943  
831.656.2026

mcghee@cs.nps.navy.mil

Xiaoping Yun\*  
Department of Electrical &  
Computer Engineering  
Naval Postgraduate School  
Monterey, California 93943  
831.656.2629

yun@nps.navy.mil

Michael J. Zyda\*  
Director of the MOVES  
Institute  
Naval Postgraduate School  
Monterey, California 93943  
831.656.2305

zyda@movesinstitute.org

## ABSTRACT

*Rigid body orientation can be determined without the aid of a generated source using nine-axis MARG (Magnetic field, Angular Rate, and Gravity) sensor unit containing three orthogonally mounted angular rate sensors, three orthogonal linear accelerometers and three orthogonal magnetometers. This paper describes a quaternion-based complementary filter algorithm for processing the output data from such a sensor. The filter forms the basis for a system designed to determine the posture of an articulated body in real-time. In the system the orientation relative to an Earth-fixed reference frame of each limb segment is individually determined through the use of an attached MARG sensor. The orientations are used to set the posture of an articulated body model. Details of the fabrication of a prototype MARG sensor are presented. Calibration algorithms for the sensors and the human body model are also presented. Experimental results demonstrate the effectiveness of the tracking system and verify the correctness of the underlying theory.*

## General Terms

Algorithms, Performance, Human Factors.

## Keywords

Virtual environments, body tracking, inertial / magnetic sensors, quaternions, complementary filtering.

## 1. INTRODUCTION

Currently available motion tracking technologies are limited by their reliance on a generated signal or a necessity for the tracked body and fixed stations around a working volume to remain with in sight of one another. In either case there is a requirement to maintain some type of link over a distance. Regardless of the type

of signal used, it can be generally referred to as a "source." Usually, the effective range over which the link may be maintained is limited [20]. Update rates may be limited by the physical characteristics of the source used. Interference with or distortion of the source will at best result in erroneous orientation and position measurements [21]. If the link is broken, a complete loss of track will result [19, 9].

Advances in the field of miniature sensors over the last decade make possible inertial/magnetic tracking of the three degrees of orientation of human body limb segments based on the passive measurement of physical quantities that are directly related to the rate of rotation and orientation of a rigid body. The "sourceless" nature of this technique makes possible full body posture tracking of multiple users over an area that is only limited by the range of a wireless LAN. Since orientation estimates are based only on passive measurements, nearly all latency in such a system is due to the computational demands of the data processing algorithms involved and not physical characteristics of the generated source.

This paper briefly presents the theory for a quaternion based complementary attitude estimation filter [15] and a prototype inertial/magnetic human body tracking system based upon it [1]. The filter is designed to process data output by nine-axis MARG (Magnetic Angular Rate Gravity) sensors and produce an orientation estimate expressed in quaternion form. Each MARG sensor contains three orthogonal angular rate sensors, three orthogonal linear accelerometers and three orthogonal magnetometers. Estimation error is minimized using Gauss-Newton iteration. Drift is corrected continuously without any requirement for still periods.

Body posture is determined by estimating individual limb segment orientations through the attachment of MARG sensors. The orientation estimates are used to animate a simple human model or *avatar* in real-time. The model directly accepts limb segment orientations in quaternion form relative to an Earth-fixed reference frame. Simple calibration procedures determine sensor scale factors and null points for the MARG sensors as well as account for offsets between the sensor coordinate frames and the frames associated with the limb segments to which they are attached.

Permission to make digital or hard copies of all or part of this work for personal or classroom use is granted without fee provided that copies are not made or distributed for profit or commercial advantage and that copies bear this notice and the full citation on the first page. To copy otherwise, or republish, to post on servers or to redistribute to lists, requires prior specific permission and/or a fee.

VRST'01, November 15-17, 2001, Banff, Alberta, Canada.

Copyright 2001 ACM 1-58113-385-5/01/0011...\$5.00.

---

\* MOVES Institute, Naval Postgraduate School, Monterey CA 93943

To track the posture of the entire human body, approximately fifteen nine-axis units would be required. One sensor would be attached to each limb segment to be tracked. The exact number of sensors needed would depend upon the desired motion tracking detail to be captured. Three such sensors were used in the system described here.

## 2. Quaternion Based Complementary Attitude Filter

Figure 1 is a block diagram of the complementary quaternion-based attitude estimation filter. The filter inputs are from a three-axis angular rate sensor ( $p, q, r$ ), a three-axis accelerometer ( $h_1, h_2, h_3$ ), and a three-axis magnetometer ( $b_1, b_2, b_3$ ). Its output is a quaternion representation of the orientation of the tracked object.

Noiseless, unbiased rate sensor data could be processed to obtain a rate quaternion

$$\dot{q} = \frac{1}{2}q \otimes (0 \ p \ q \ r) = \frac{1}{2}q \otimes {}^B\omega \quad (1)$$

where  $q$  is a quaternion representing the current orientation, the indicated product is a quaternion product and the superscript  $B$  means measured in the body reference frame. Single integration of  $\dot{q}$  would produce a quaternion, which describes orientation. However, in an environment containing noise and errors, the output of angular rate sensors would tend to drift over time. Thus, rate sensor data can be used to determine orientation only for relatively short periods of time unless this orientation is continuously corrected using “complementary” data from additional sensors.

Gravity and the earth's magnetic field provide two fixed vectors that can be used to determine orientation. Accelerometers measure the combination of forced linear acceleration and the reaction force due to gravity. That is,

$$\vec{a}_{measured} = \vec{a} + \vec{g} \quad (2)$$

When averaged over time, an accelerometer triad can return the components of the gravity vector or the local vertical. Determination of this vector allows correction of orientation relative to a vertical axis. Similarly, magnetometers measure the local magnetic field in body coordinates. This information is used to correct rate sensor drift errors in the horizontal plane. Thus, the vectors derived from accelerometer and magnetometer data comprise a second complementary method of determining orientation.

### 2.1 Parameter Optimization

Combining the complementary sensor inputs is regarded as a parameter optimization problem with the goal of minimizing modeling error. The three orthogonally mounted accelerometers return an approximation to the local vertical, the unit vector  $h$ . The magnetometer returns the direction of the local magnetic field, the unit vector  $b$ . These two vector quantities expressed in body coordinates as *pure vector quaternions* are

$$h = [0 \ h_1 \ h_2 \ h_3] \quad b = [0 \ b_1 \ b_2 \ b_3] \quad (3)$$

Combining the vector parts from Eq. (3) produces a 6 x 1 *measurement vector*

$$y_o = [h_1 \ h_2 \ h_3 \ b_1 \ b_2 \ b_3]^T \quad (4)$$

Gravity in earth coordinates is always down and can be expressed as the down unit vector in quaternion form as

$$m = [0 \ 0 \ 0 \ 1] \quad (5)$$

The local magnetic field in earth coordinates, once determined and normalized, can be expressed in quaternion form as

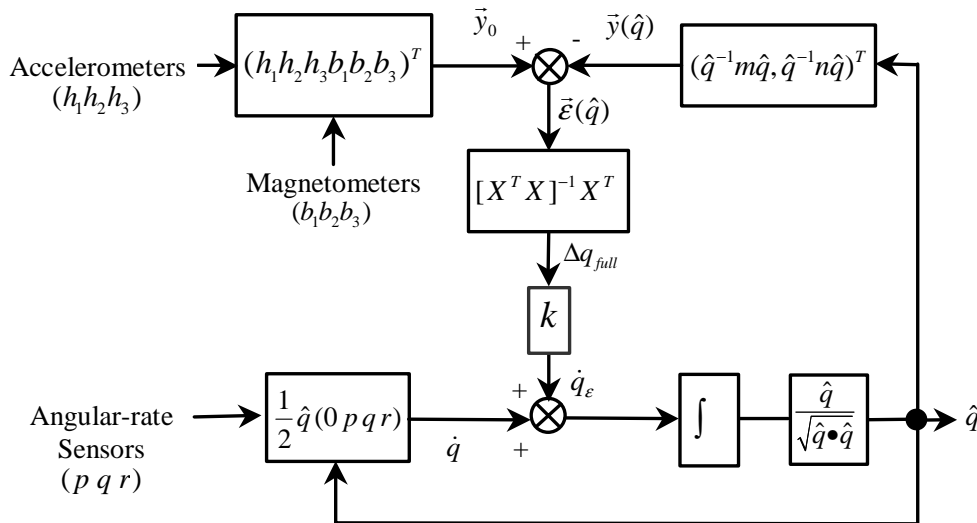

Figure 1: Quaternion-Based Orientation Filter

$$n = [0 \quad n_1 \quad n_2 \quad n_3]^T \quad (6)$$

Eq. (5) and Eq. (6) are mapped from the earth fixed frame to the body frame through quaternion multiplication by [13]

$$h = q^{-1}mq \quad b = q^{-1}nq \quad (7)$$

Combining the vector parts of Eq. (7) into a single 6 x 1 *computed measurement vector* produces

$$\bar{y}(q) = [h_1 \quad h_2 \quad h_3 \quad b_1 \quad b_2 \quad b_3]^T \quad (8)$$

The difference between the actual measurements and the computed measurement is the *modeling error*

$$\bar{\epsilon}(q) = \bar{y}_0 - \bar{y}(q) \quad (9)$$

In viewing Eq. (9), note that if in Eq. (7) there is no measurement noise, the minimum difference between the measured and computed values will equal the zero vector. The square of the filter modeling error is termed the *criterion function*

$$\varphi(q) = \bar{\epsilon}^T(q) \bar{\epsilon}(q) \quad (10)$$

In the current version of the filter, the criterion function is minimized using Gauss-Newton iteration [17]. This method is based on linearized least squares regression analysis where  $\bar{y}_0$  is considered a vector of data points and  $\bar{y}(q)$  is a vector to be fitted to those points. The full correction step to the measured rate quaternion is [17]

$$\Delta q_{full} = [X^T X]^{-1} X^T \epsilon(\hat{q}) = S^{-1} X^T \epsilon(\hat{q}) \quad (11)$$

where  $\hat{q}$  is the previous estimate for  $q$  and the  $X$  matrix is defined as [15]

$$X_{ij} = \left[ \frac{\partial y_i}{\partial q_j} \right] \quad (12)$$

Eq. (11) treats  $m$  and  $n$  as if they are perfect measurements of gravity and the local magnetic field. In dealing with data corrupted by noise, a scalar multiplier is used and

$$\Delta q_{partial} = \alpha [X^T X]^{-1} X^T \bar{\epsilon}(\hat{q}) \quad (13)$$

where

$$\alpha = k \Delta t \quad (14)$$

and  $k$  represents the filter gain value. Thus, for discrete time step integration, the next estimate of orientation would be

$$\begin{aligned} \hat{q}_{n+1} &= \hat{q}_n + \frac{1}{2} \hat{q}^B \omega \Delta t + \alpha [X^T X]^{-1} X^T \epsilon(\hat{q}_n) \\ &= \hat{q}_n + k \Delta t \Delta q_{full} + \dot{q}_{measured} \Delta t \end{aligned} \quad (15)$$

## 2.2 Reduced Order Filter

If  $\hat{q}$  is not constrained to unit length as depicted in Figure 1, a unique solution to the optimization problem no longer exists and the  $X$  matrix will not be of full rank. In this case the *regression matrix*

$$S = X^T X \quad (16)$$

will be singular and can not be inverted.

A more efficient alternative to the computation of  $\Delta \hat{q}$  results from noting that if

$$\hat{q}_{new} = \hat{q}_{old} + \Delta q_{full} \quad (17)$$

and if both  $\hat{q}_{new}$  and  $\hat{q}_{old}$  are unit quaternions, then any small  $\Delta q_{full}$  must be orthogonal to  $\hat{q}$ . That is, the only way to alter a unit vector while maintaining unit length is to rotate it, and for small rotations  $\Delta q$  must be tangent to the unit four-dimensional sphere defined by

$$q \otimes q^* = |q|^2 = 1 \quad (18)$$

where  $q^*$  is the *conjugate* of  $q$  [13]. From the Orthogonal Quaternion Theorem of [15], if  $p$  and  $q$  are any two quaternions, then  $p$  is orthogonal to  $q$  if and only if  $p$  is the quaternion product of  $q$  and a unique vector  $v$  (real part equal to zero) where  $v$  is given by

$$v = q^{-1} \otimes p \quad (19)$$

Accordingly  $\Delta q$  can be written in the form

$$\Delta q = q \otimes v = \hat{q} \otimes (0 \quad v_1 \quad v_2 \quad v_3) \quad (20)$$

With this constraint, linearization of the computed measurement vector,  $y(q)$ , in Figure 1, yields

$$y(q + \Delta q) = y(q) + X \Delta q = y(q) + X (q \otimes (0 \quad v_1 \quad v_2 \quad v_3))^T \quad (21)$$

and consequently:

$$\frac{\partial y}{\partial v_1} = X (q \otimes (0 \quad 1 \quad 0 \quad 0)) = X (q \otimes i)^T \quad (22)$$

$$\frac{\partial y}{\partial v_2} = X (q \otimes (0 \quad 0 \quad 1 \quad 0)) = X (q \otimes j)^T \quad (23)$$

and

$$\frac{\partial y}{\partial v_3} = X (q \otimes (0 \quad 0 \quad 0 \quad 1)) = X (q \otimes k)^T \quad (24)$$

Thus, when Gauss-Newton iteration is applied to unit quaternions, it is sufficient to solve for only three unknowns rather than four as

in the methods for estimation of  $\Delta q_{full}$  in Eq. (11). That is, if  $X$  is the  $6 \times 3$  matrix

$$X_v = \begin{bmatrix} \frac{\partial y}{\partial v_1} & \frac{\partial y}{\partial v_2} & \frac{\partial y}{\partial v_3} \end{bmatrix} \quad (25)$$

then,

$$\Delta v_{full} = [X_v^T X_v]^{-1} X_v \bar{\epsilon}(\hat{q}) \quad (26)$$

and

$$\Delta q_{full} = \hat{q} \otimes (0, \Delta v_{full}) \quad (27)$$

Incorporation of the above into the Gauss-Newton algorithm, notably simplifies the computation of the  $\Delta q$  quaternion since it requires only a  $3 \times 3$  matrix inversion rather than the  $4 \times 4$  matrix inversion of the basic algorithm. This is important since best algorithms for matrix inversion are of  $O(n^3)$  complexity [7].

### 2.3 Weighed Least Squares Regression

Referring again to Figure 1, the possibility exists of putting greater or less reliance on magnetometer data in comparison to accelerometer data. This could come about because one or the other of these signals could prove to be less accurate (or noisier) than the other. This can be achieved by merely redefining the error vector,  $\epsilon$ , as:

$$\epsilon(q) = \begin{bmatrix} y_{0_1} - y(q)_1 \\ y_{0_2} - y(q)_2 \\ y_{0_3} - y(q)_3 \\ \rho(y_{0_4} - y(q)_4) \\ \rho(y_{0_5} - y(q)_5) \\ \rho(y_{0_6} - y(\hat{q})_6) \end{bmatrix} \quad (28)$$

Setting  $\rho > 1$  emphasizes magnetometer data, while  $0 < \rho < 1$  puts greater weight on accelerometer data. This change alters the  $X$  matrix by multiplying the last three elements of each column by  $\rho^2$ . If a detailed statistical model is available for magnetometer and accelerometer errors for a particular experimental setting then, at least conceptually, the best value for  $\rho$  could be obtained from linear estimation theory [5]. In the absence of such statistical data, it is probably more productive to think of  $\rho$  as a "tunable" parameter adjusted by "eyeball optimization" in a given situation.

## 3. System Overview

The prototype inertial/magnetic body tracking system in this research was implemented with several goals in mind. Among these were validation of the quaternion filter algorithm in a physical system, demonstration of the practicality and robustness of inertial and magnetic orientation tracking in real-time, and creation of a test-bed for further experiments. Several features are

considered imperative if these goals are to be met. Among these are:

- Orientation tracking of any three or more human limb segments using nine-axis MARG sensors
- Sufficient dynamic response and update rate (100 HZ or better) to capture fast human body motions
- Calibration of individual sensors without the use of any specialized equipment
- Simplified human kinematic model based entirely on quaternions capable of accepting orientation parameters relative to an earth fixed reference frame in quaternion form
- Automatic accounting for the peculiarities related to the mounting of a sensor on an associated limb segment

### 3.1 System Hardware

Figure 2 is a diagram of the prototype system hardware. Depicted are three body-mounted MARG sensors outputting analog signals to three I/O connection boards. The output from each connection board is digitized by an associated A/D converter card. The cards themselves are mounted in a standard Wintel desktop computer. All data processing and rendering calculations are performed by software running on this single processor machine.

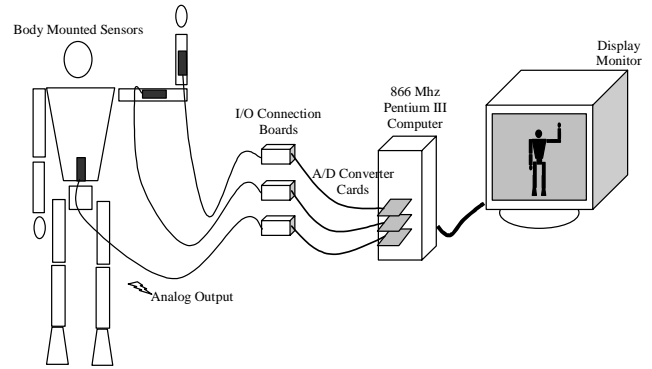

Figure 2: Prototype Inertial and Magnetic Body Tracking System [2]

#### 3.1.1 MARG Sensors

Three prototype MARG sensors (Figure 3) were custom built using off-the-shelf, low cost components. Each sensor package measures 10.1 x 5.5 x 2.5 cm. The analog output of the sensor is connected to a breakout header via a thin VGA monitor cable. Output range is 0-5 vdc. The power requirement of the sensors is 12 vdc at approximately 50 milliamperes. The primary sensing components are a Crossbow CXL04M3 triaxial accelerometer [8], a Honeywell HMC2003 3-axis magnetometer [11] and three Tokin CG-16D series miniature angular rate sensors mounted in an orthogonal configuration [22]. The individual components are integrated using a single integrated circuit board with the accelerometers mounted separately. Rate sensor output voltage is amplified by a factor of five and filtered to attenuate rate sensor oscillator noise. All three MARG sensors were fabricated by McKinney Technology of Prunedale, California [18].

Integration of a biased angular rate signal will cause a steady state error in a complementary filter. In earlier body tracking work, the angular rate sensors were bias compensated in software [3]. In

order to achieve better system performance, in future systems this correction should be hardware implemented in the rate sensor conditioning circuitry using capacitive coupling.

Manufacturer's literature states that HMC1001/2 magnetometer saturation occurs due to the influence of a strong magnetic field in excess of 30 gauss, which can cause the polarity of the MR film magnetization to flip [6]. Following such an upset field, a strong restoring magnetic field must be momentarily applied to restore, or set, the sensor characteristics. The effect is commonly referred to as applying a set or reset pulse. The sensors used in this research incorporate a manual set/reset circuit to electrically restore the magnetometers to proper operation. The purpose of the associated circuit is to set or reset the permalloy film contained in the individual magnetometers by applying a current pulse of 3-4 amps for approximately 20-50 nsec.

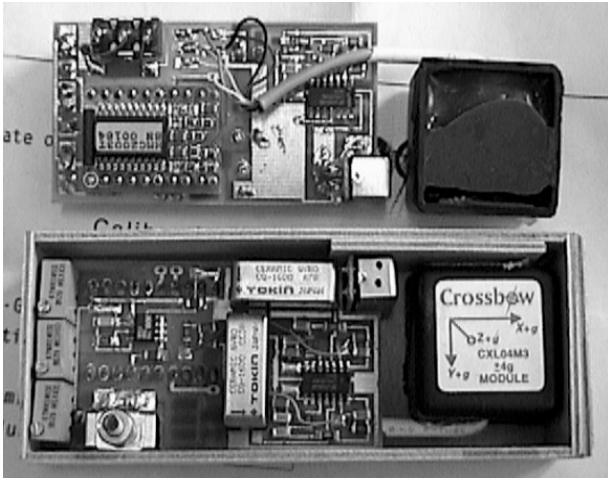

Figure 3: Prototype MARG Sensor [18]

### 3.2 System Software

The system software implements the estimation as well as calibration algorithms which make possible tracking of human body segments using MARG sensors. The object oriented software for this research was written in C++. Estimation and rendering events are window system timer driven at 100 Hz and 25 Hz respectively. The code is single threaded. It runs on a standard 866 MHz Intel Pentium III platform under the Windows 2000 operating system.

#### 3.2.1 Sensor Calibration

In order for the system to operate properly, it is imperative that the null point and scale factor of each individual component of the MARG sensors be determined prior to commencing limb tracking. Unless the characteristics of the sensors themselves change, calibration need only be accomplished once. However, due to variations in the direction of the local magnetic field vector, better performance is to be expected if the direction of this reference is determined before each tracking session.

An individual linear accelerometer can be calibrated by placing it in a vertical position to sense gravity in one direction and then turning it over to sense gravity in the other. Halfway between the readings taken is the null point.

$$accel\ null = \frac{accel\ max + accel\ min}{2} \quad (29)$$

Multiplication of a correct scale factor times the accelerometer output values will result in a product of 1 g in one direction and -1 g in the other. This scale factor can be found using

$$accel\ scale = \frac{(accel\ units) \times 2}{accel\ max - accel\ min} \quad (30)$$

An obvious method of magnetometer calibration is very similar to that used for accelerometers. Instead of orienting each sensor relative to the gravity vector, each magnetometer would have to be placed in a position in which it can sense the maximum strength of the local magnetic field along both its negative and positive axes.

Determination of the null point of an angular rate sensor is achieved by recording and averaging over some time period the output of a static sensor. Scale factors are estimated by integrating the output of angular rate sensor as it is subjected to a known angle of rotation. The scale factor for a rate sensor can therefore be determined following a known rotation using

$$scale\ factor = \frac{known\ rotation}{estimated\ rotation} \quad (31)$$

where the estimated rotation term is the result of integrating the output of the sensor with a scale factor of unity.

From the above, a MARG sensor can be completely calibrated using a level platform and a simple compass to indicate the direction of the local magnetic field. In this research each sensor was calibrated by placing it in six positions which allowed each accelerometer to sense gravitation acceleration in both the positive and negative directions, subjecting each rate sensor to one or more known rotations and rotating the MARG sensor in a manner such that maximum and minimum local magnetic field readings could be obtained for each magnetometer.

#### 3.2.2 Quaternion Based Human Body Model

The vertices of an individual segment of the human model can be described relative to a z-axis down coordinate system that is attached to the inboard end of the segment [2]. If the sensor and limb segment coordinate axes are aligned, the orientation of an individual limb segment could be set by applying to each vertex,  $v$ , the quaternion rotation

$$q_{sensor} \otimes v \otimes q_{sensor}^* \quad (32)$$

where the unit quaternion  $q_{sensor}$  is the estimated orientation produced by the filter processing the sensor output.

Misalignment between the sensor and limb segment axes can be taken into account by performing an additional fixed rotation using an offset quaternion

$$q_{sensor} \otimes (q_{offset} \otimes v \otimes q_{offset}^*) \otimes q_{sensor}^* \quad (33)$$

to each vertex, where  $q_{offset}$  is the offset quaternion for the limb of the vertex.

When the human model is in the reference position, the limb segment coordinate axes are aligned with the corresponding Earth-fixed axes. That is the x-axis for each limb segment points toward the local north, the y-axis points east and the z-axis points down. The offset quaternion for each limb segment can be derived

by noting that while the user is in the reference position the equation

$$v = q_{sensor} \otimes q_{offset} \otimes v \otimes q_{offset}^* \otimes q_{sensor}^* \quad (34)$$

holds true. Complete compensation for the way in which all sensors are attached to the limbs of a tracked subject can therefore be accomplished by simply setting  $q_{offset}$  for each limb segment to the inverse of the associated  $q_{sensor}$  while the subject to be tracked is standing in a predetermined reference position.

To set the position of an individual limb segment it is necessary to find a vector that describes the location of the inboard end of the limb segment. Once this vector is found the final position of each vertex can be calculated through addition of this vector to the rotated coordinates of each vertex. Thus, the final position of a limb segment vertex is given by

$$p_{trans} + q_{sensor} \otimes (q_{offset} \otimes v \otimes q_{offset}^*) \otimes q_{sensor}^* \quad (35)$$

where  $p_{trans}$  is the vector sum of rotated translation vectors associated with limb segments that are between the body origin and the limb segment being positioned.

#### 4. System Performance

Quantitative and qualitative experiments were performed to get an initial estimate of the accuracy and robustness of the system under various dynamic and static conditions. The static experiments related to the stability, convergence properties, and accuracy of the orientation estimates produced by the quaternion attitude filter algorithm when processing MARG sensor data. The qualitative experiments examine the performance of the system as a whole in relationship to the goal of robust posture estimation. The performance of the system while using differential weighting of sensor data as well as increased drift correction intervals was also investigated [2].

##### 4.1 Static Stability

The drift characteristics of the quaternion filter algorithm and the MARG sensor over extended periods were evaluated using static tests. Figure 4 graphically depicts the drift of each of the four components of the quaternion estimate produced by the filter. It can be observed through examination of Figure 4 that average total drift is about 1%. During the experiment shown, the filter gain,  $k$  (Eq. (14)), was set to unity. Equal weighting was given to both magnetometer and accelerometer data. It is expected that increasing the filter gain to 4.0 would reduce the drift error by a factor of four or to about 0.25 percent. Further experiments [2] indicated that nearly all drift was due to bias in the rate sensors. Experiments are currently underway using improved sensors containing rate-sensor capacitive coupling conditioning circuitry designed to remove these biases.

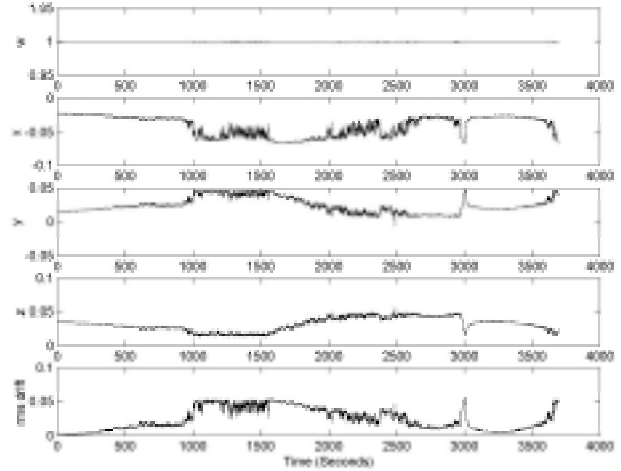
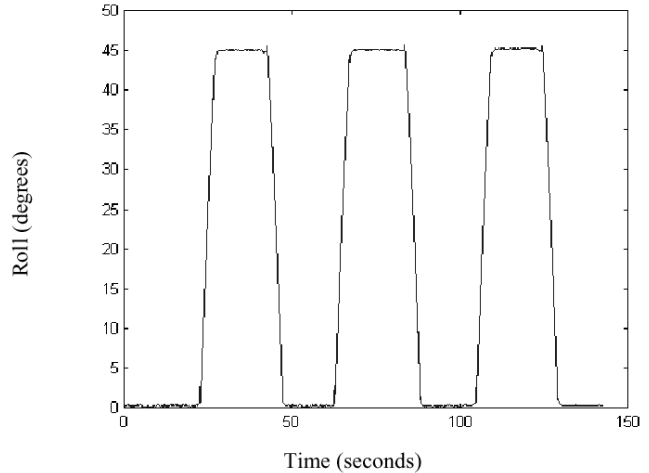

**Figure 4: Quaternion Real And Vector Parts And RMS Drift During One Hour Static Test Of Orientation Estimate Stability,  $k = 1.0$ ,  $\rho = 1.0$**

##### 4.2 Dynamic Response and Accuracy

Preliminary experiments were conducted to establish the accuracy of the orientation estimates and the dynamic response of the system. These experiments were completed using a Hass rotary tilt table. The preliminary test procedure consisted of repeatedly cycling the sensor through various angles of roll, pitch and yaw at rates ranging from 10 to 30 deg./sec.

Figure 5 is a typical result of the dynamic accuracy experiments. The estimates produced by the tracking system are presented in Euler angle form. Accuracy was measured to be better than one degree. The overall smoothness of the plot shows excellent dynamic response. The small impulses observed each time motion is initiated are hypothesized to be linear acceleration effects exaggerated by the “whipping” motion of the extension on which the sensor was mounted.



**Figure 5: 45 Degree Roll Excursions At 10 Degrees/Second**

##### 4.3 Posture Estimation

The purpose of the human body tracking system is to estimate the orientation of multiple human limb segments and use the resulting estimates to set the posture of the human body model that is visually displayed. Numerous experiments were conducted to

qualitatively evaluate and demonstrate this capability. In each experiment three MARG sensors were attached to the limb segments to be tracked. Due to the minimal number of sensors available, tracking was limited to a single arm or leg. In the case of arm and limb segments, sensor attachment was achieved through the use of elastic bandages. In most cases this method appeared to keep the sensors fixed relative to the limb. Body tracking was performed using various gains. Video recordings of the system in normal operation indicate that posture estimation was accurate and showed very little lag. Figure 6 and Figure 7 depict inertial tracking of various limb segments. A quicktime movie of the these experiments may be downloaded at <http://npsnet.org/~bachmann/research.htm>

#### 4.4 Accelerometer/Magnetometer Only Tracking

Experiments conducted with no rate sensor data input showed that the system could accurately determine posture in applications not involving rapid movement using only accelerometers and magnetometers. Overall, the performance of the system without rate sensors indicates that a less expensive system could be constructed using six axis sensors containing only accelerometers and magnetometers. Such a system would function well in low acceleration applications. It would not however be appropriate to feedback control applications requiring a quicker response [16].

#### 5. Future Work

Current technology will permit the construction of sensors that are much smaller than the prototype MARG sensors described here. An optimal inertial sensor would have the same size and form factor as a wristwatch. It would include an embedded microprocessor on which the filter algorithm is implemented as well as an analog to digital converter. The sensor would have a self-contained power source and would wirelessly transmit orientation data. Efforts are currently being made to untether the user of the sensor system by feeding MARG sensor data to a wearable computer. Bluetooth technology [4] is being investigated as a means to create a completely wireless sensor.

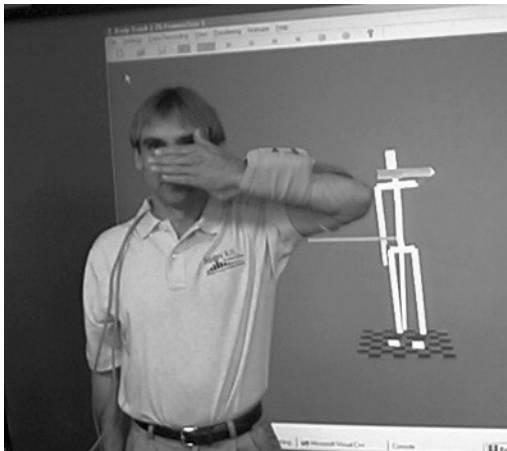

**Figure 6 Inertial/Magnetic Tracking Of The Arm Using Three Marg Sensors [2]**

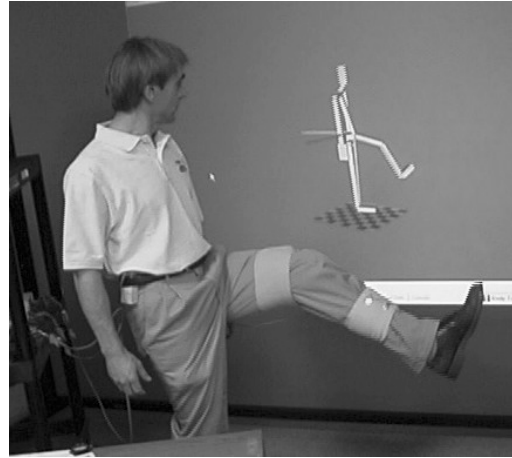

**Figure 7: Inertial/Magnetic Tracking Of The Leg Using Three MARG Sensors [2]**

Filter research has continued with the development of an extended Kalman Filter for real-time estimation of rigid body orientation [14]. Non-real-time static and dynamic testing of the filter has been performed with synthetic data and real sensor data. In addition, a more efficient formulation of the X matrix is currently being evaluated through simulation. This new derivation will have particular significance as the quaternion filter algorithm is implemented on microprocessors contained within the sensors.

The ultimate goal of this project is to insert humans into a networked virtual environment. A network of 15 MARG sensors will track body posture. In order to accurately place the of the user's avatar in the virtual environment, it will be necessary to know body location as well as the posture of the body. To achieve this, the position of one body limb segment must be tracked. Although several technical challenges exist [12], RF positioning is still seen as the technology which will best complement the sourceless capabilities of inertial/ magnetic sensing and enable tracking of a multiple users over a wide area. While indoor tracking of this type is still under development, currently available differential GPS may provide adequate position tracking for some outdoor applications.

#### 6. Summary and Conclusions

This research has demonstrated an alternative technology for tracking the posture of an articulated rigid body. The technology is based on the use of inertial/magnetic sensors to independently determine the orientation of each link in the rigid body. At the core of the system is an efficient complementary filter that uses a quaternion representation of orientation. The filter can continuously track the orientation of human body limb segments through all attitudes without singularities. Drift corrections are made continuously with no requirement for still periods.

Articulated body posture is represented using a model based entirely on quaternion/vector pairs [9]. Individual limb segments are oriented independently using a quaternion representation of the orientation relative to an earth-fixed reference frame. The underlying simplicity of the model makes possible a quick and accurate calibration that compensates for misalignments between sensor and limb segment coordinate axes.

Due to its sourceless nature, inertial/magnetic tracking could overcome many of the limitations of motion tracking technologies currently in widespread use. Combined with an appropriate



positioning system, it is potentially capable of providing wide area tracking of multiple users for synthetic environment and augmented reality applications.

## 7. Acknowledgements

The authors wish to acknowledge the support of the U. S. Army Research Office (ARO) under Proposal No. 40410-MA and the U. S. Navy Modeling and Simulation Management Office (N6M) for making this work possible.

## 8. REFERENCES

- [1] Bachmann, E., McGhee, R., Yun X. & Zyda, M., "Real-Time Tracking and Display of Human Limb Segment Motions Using Sourceless Sensors and a Quaternion-Based Filtering Algorithm - Part II: Calibration and Implementation," MOVES Academic Group Technical Report NPS-MV-01-003, Naval Postgraduate School, Monterey, CA., 2001 (Available at <http://npsnet.org/~moves/TechReports/NPS-MV-01-003.pdf>).
- [2] Bachmann, E., *Inertial and Magnetic Angle Tracking of Limb Segments for Inserting Humans into Synthetic Environments*, Ph.D. dissertation, Naval Postgraduate School, Monterey, CA., 2000. (Available at <http://npsnet.org/~bachmann/>)
- [3] Bachmann, E., Duman I., Usta, U., McGhee R., Yun, X., & Zyda, M., "Orientation tracking for Humans and Robots Using Inertial Sensors," *International Symposium on Computational Intelligence in Robotics & Automation (CIRA 99)*, Monterey, CA, pp.187-194, 1999.
- [4] Bray, J. & Sturman, C., *Bluetooth: Connect without Cables*, Prentice Hall, Inc., 2000.
- [5] Brown, R. & Hwang, P., *Introduction to Random Signals and Applied Kalman Filtering, Second Edition*, John Wiley and Sons, Inc., New York, NY., 1992.
- [6] Caruso, M., *Set/Reset Pulse Circuits for Magnetic Sensors*, Honeywell, Inc., AN-201., 1995.
- [7] Cormen, T., Leiserson, C., & Rivest, R. *Introduction to Algorithms*, McGraw-Hill, New York, 1994.
- [8] Crossbow Inc., *Crossbow CXL04M3 Data Sheet*, 1998.
- [9] Durlach, N. & Mayor, A. (Eds.), *National Research Council, Virtual Reality: Scientific and Technological Challenges*, National Academy Press, Washington, D.C., pp. 188-204, 306-317, 1995.
- [10] Funda, J., Taylor, R., & Paul, R., "On Homogeneous Transforms, Quaternions, and Computational Efficiency," *IEEE Transactions on Robotics and Automation*, Vol. 6, No. 3, pp. 382-388, 1990.
- [11] Honeywell Inc., *Honeywell Three-Axis Magnetic Sensor Hybrid, HMC2003*, 1998.
- [12] IntegriNautics Corporation, Private communication with development engineer. Menlo Park, CA 94025, 2000.
- [13] Kuipers, J., *Quaternions and Rotation Sequences*, Princeton University Press, Inc., Princeton, NJ, 1998.
- [14] João Luís Marins , Xiaoping Yun , Eric R. Bachmann, Robert B. McGhee, and Michael J. Zyda, "An Extended Kalman Filter for Quaternion-Based Orientation Estimation Using MARG Sensors," *Proc. of 2001 IEEE/RSJ International Conference on Intelligent Robots and Systems (IROS)*, October 29- November 3, 2001, Maui, Hawaii, USA.
- [15] McGhee, R., Bachmann, E., Yun X. & Zyda, M. "Real-Time Tracking and Display of Human Limb Segment Motions Using Sourceless Sensors and a Quaternion-Based Filtering Algorithm - Part I: Theory," MOVES Academic Group Technical Report NPS-MV-01-001, Naval Postgraduate School, Monterey, CA. 2000. (Available at <http://npsnet.org/~moves/TechReports/NPS-MV-01-001.pdf>)
- [16] McGhee, R., Nakano, E., Koyachi, N., & Adachi, H., "An Approach to Computer Coordination of Motion for Energy-Efficient Walking Machines," *Bulletin of Mechanical Engineering Laboratory, Japan*, No. 43., 1986.
- [17] McGhee, R., "Some Parameter-Optimization Techniques," *Digital Computer User's Handbook*, McGraw-Hill, pp. 234-253, 1967.
- [18] McKinney, D., McKinney Technology, 9 Glen Avenue, Prunedale, CA, 93907, [doug@mt.to](mailto:doug@mt.to) .
- [19] Meyer, K., Applewhite, H., & Biocca, F., "A Survey of Position Trackers," *Presence: Teleoperators and Virtual Environments*, Vol. 1, No. 2, pp. 173-200, 1992.
- [20] Molet, T., Aubel, A., Tolga, C., Carion, S., Lee, E., Naagnenat-Thalmann, N., Hoser, H., Pandzic, I., Sannier, G., & Thalmann, D., "Anyone for Tennis," *Presence: Teleoperators and Virtual Environments*, Vol. 8, No. 2, MIT Press, Cambridge MA., pp. 140-156, 1999.
- [21] Nixon, M., McCallum, B., Fright, W., & Price, N. "The effects of Metals and Interfering Fields on Electromagnetic Trackers," *Presence: Teleoperators and Virtual Environments*, Vol. 7, No. 2, MIT Press, Cambridge, MA, pp. 204-218, 1998.
- [22] Tokin American Inc., *Tokin CG16D Solid State Rate Sensor Data Sheet*, [http://www.tokin.com/Tokin\\_America\\_Products/46/p46c/p46c.html](http://www.tokin.com/Tokin_America_Products/46/p46c/p46c.html), 1998.