

Hindawi Publishing Corporation  
International Journal of Digital Multimedia Broadcasting  
Volume 2009, Article ID 382695, 6 pages  
doi:10.1155/2009/382695

## Research Article

# Low-Cost Transceiver Architectures for 60 GHz Ultra Wideband WLANs

**S. O. Tatu, E. Moldovan, and S. Affes**

*Laboratoire LRF, Center Énergie, Matériaux et Télécommunications, Institut National de la Recherche Scientifique, 800 de la Gauchetière Ouest, Montréal, R6900, Quebec, Canada H5A 1K6*

Correspondence should be addressed to S. O. Tatu, [tatu@emt.inrs.ca](mailto:tatu@emt.inrs.ca)

Received 23 November 2008; Accepted 2 February 2009

Recommended by Daniel Iancu

Millimeter-wave multiport transceiver architectures dedicated to 60 GHz UWB short-range communications are proposed in this paper. Multi-port circuits based on 90° hybrid couplers are intensively used for phased antenna array, millimeter-wave modulation and down-conversion, as a low-cost alternative to the conventional architecture. This allows complete integration of circuits including antennas, in planar technology, on the same substrate, improving the overall transceiver performances.

Copyright © 2009 S. O. Tatu et al. This is an open access article distributed under the Creative Commons Attribution License, which permits unrestricted use, distribution, and reproduction in any medium, provided the original work is properly cited.

## 1. Introduction

With the rapid growth of wireless technologies, ubiquitous and always-on wireless systems in homes and enterprises are expected to emerge in the near future. Facilitating these ubiquitous wireless systems is one of the ultimate goals of the next generations (4G and beyond) wireless technologies being discussed worldwide today. This increasing interest for wireless connectivity has pushed the regulatory agencies to provide new opportunities for unlicensed spectrum usage with fewer restrictions on radio parameters. In order to provide more flexibility in spectrum sharing, the FCC introduced (i) an underlay approach with severe restrictions on transmitted power levels with a requirement to operate over the occupied and the unoccupied spectrum across the 3.1–10.6 GHz band and (ii) an opening of 7 GHz unlicensed spectrum at millimeter-wave frequencies around 60 GHz, where oxygen absorption limits long-distance interference. Both spectrums are suitable for ultra-wideband (UWB) short-range wireless local area networks (WLANs) dedicated to high data rate applications, which could be high-speed home or office wireless networking and entertainment, such as high-definition television (HDTV).

Conventional microwave UWB technology (3.1–10.6 GHz band) is one of the most active focus areas in academia, industry, and regulatory circles. Because of the power spectral density limitations, (−41 dBm/MHz)

the microwave UWB overlays existing wireless services (GPS, PCS, Bluetooth, and IEEE 802.11 WLANs) without significant interferences.

Compared to the conventional UWB technology, 60 GHz mm-wave communications will operate in the currently unlicensed spectrum (57–64 GHz) and will easily provide data rates up to several Gb/s [1–3]. In the case of comparable bandwidths and data rates, an important advantage of using millimeter-wave bands is the reduced ratio between the bandwidth and the central frequency, leading the way to transceiver simplicity. However, the 60 GHz indoor channel presents a challenging environment for UWB wireless communications. Therefore, future UWB WLANs will certainly be achieved using smart antenna arrays to reduce the multipath effects together with the link budget and the power consumption. The inherent power limitations and wireless channel propagation characteristics dictate the short-range capability of 60 GHz communications. The strong signal attenuation allows an efficient reuse of the spectrum. This helps to create small indoor cells for hot spot secure wireless communications.

## 2. Fabrication Technologies

The successful integration of circuits and modules into the same substrate is the key to a significant cost reduction.

In particular, GaAs technology has been developed to the point where 60 GHz monolithic microwave integrated circuits (MMIC) are production ready [1, 3]. An alternative technology based on silicon germanium (SiGe) promises to provide low-cost millimeter-wave front-end MMICs, simultaneously maintaining the performances of GaAs [1]. While complementary metal oxide semiconductor (CMOS) technology is considered as an ideal solution in terms of cost and circuit integration, RF CMOS for 60 GHz frequency requires more performance improvement [3].

A very promising technology for small-scale integration is represented by monolithic hybrid microwave integrated circuits (MHMIC) on very thin ceramic substrate. It is to be noted that coplanar wire-bond interconnections between chips and the flip chip assembly (direct electrical connection of face-down, hence “flipped”) could be low loss at 60 GHz, whereas multichip module technologies could well accommodate millimeter-wave components along with IF and baseband circuits.

A further improvement would be the monolithic integration of antennas with MMIC or MHMIC chips in order to avoid significant interconnection losses. We note that antennas are rarely integrated into the proposed front-ends, decreasing the overall performances in terms of noise figure and gain. The integration of circuits and antennas forming a single front-end module offers several benefits, such as compactness, low-power consumption, and multifunctionality.

### 3. MultiPort Millimeter-Wave Circuits and Modules for UWB Applications

The transceivers for 60 GHz WLANs must be composed by low-cost components having excellent electrical performances, designed according to the UWB transceiver requirements.

Millimeter-wave multiport circuits and modules represent a low-cost unconventional approach.

A complete multiport quadrature down-conversion theory, validated by various simulations and measurements of a Ka-band direct conversion receiver, has already been published [4]. Simulations have also been performed for a V-band multiport heterodyne receiver [5]. The multiport technology allows improved results in terms of conversion loss and requires a reduced LO power compared to the conventional methods (as low as  $-20$  dBm to perform an efficient frequency conversion), as it has recently been demonstrated in [6]. As known, a conventional diode mixer using antiparallel diodes acting at LO-driven switches requires around  $+10$  dBm LO power for the same conversion loss. The excellent isolation between the multiport RF inputs is another important advantage versus the conventional approach. Another recent study [7] proves that the multiport mixer exhibits very good suppression of harmonic and spurious products, due to the symmetry and specific multiport properties.

Figure 1 shows the block diagram of the implementation of multiport circuit for down-conversion purposes.

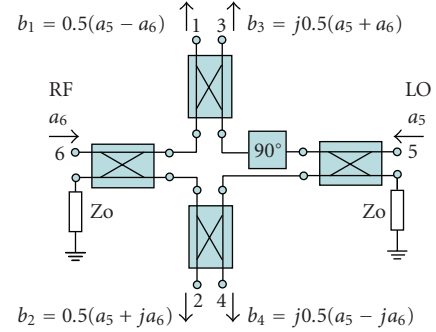

FIGURE 1: The simplified block diagram of a multiport circuit for down-conversion.

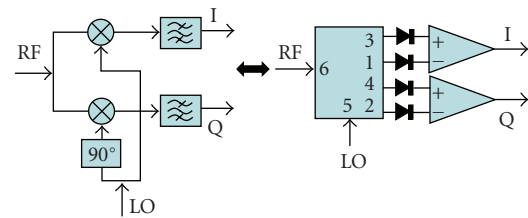

FIGURE 2: The equivalence between conventional I/Q mixer—the multiport down-converter.

The circuit uses four  $90^\circ$  hybrid couplers and a  $90^\circ$  phase shifter. The normalized output waves are represented on the same figure. As seen, the output waves are linear combination of phase-shifted input signals. The insertion loss is equal to 6 dB because each signal passes through two 3 dB couplers.

Figure 2 shows the equivalence with conventional I/Q mixer architecture. The millimeter-wave multiport in conjunction with a local oscillator and two IF differential amplifiers (IFDA) will be used in order to obtain two quadrature IF signals, avoiding the use of two costly millimeter-wave mixers and reducing the power consumption [5]. It is to be noted that these IF circuits will realize additional filtering functions.

The millimeter-wave modulator is an essential element for the transmitter. Depending on specific modulation scheme, a multiport-based modulator or a millimeter-wave switching network are proposed for low-cost UWB applications.

The multiport modulator is composed by four  $90^\circ$  hybrid couplers, a  $90^\circ$  phase shifter and two pairs of monoports having a controllable reflection coefficient, as seen in Figure 3. The phase and the amplitude of the normalized output signal are related to the monoport return loss values. Therefore, the direct modulation of a millimeter-wave signal can be easily obtained. As an example, using short or open circuits, the return loss values are equal to  $-1$  and  $+1$ , respectively, and a direct QPSK multiport modulator is obtained [8].

In addition, “II” or “T” switch circuits using diodes (having appropriate return and insertion losses at 60 GHz, and a bandwidth of several GHz) can be designed and implemented for the transposition of the microwave UWB at 60 GHz.

Intelligent antennas take advantage of both antenna technology and propagation characteristics [9, 10]. The use of such antennas in millimeter-wave front-ends has the potential to reduce multipath interference and to increase the output signal to noise ratio.

The advantages of the electronic beam scanning have been extensively discussed in literature. The primary reason for using antenna arrays is to produce a directive beam that can be electronically repositioned (scanned). The antenna arrays consist of multiple stationary antenna elements (which are fed coherently) and can use controlled phase shifters at each element to scan a beam to given angles in space.

In order to avoid the use of controlled phase shifters, for low-cost millimeter-wave applications, the use of antenna arrays based on Butler matrices is proposed. This is a multiple beam array, each input port exciting an individual beam in space. The Butler matrix is a circuit implementation of the FFT, radiating orthogonal sets of beams with uniform aperture illumination. The proposed choice is a  $4 \times 4$  Butler matrix antenna array with four orthogonal beams, spaced by  $30^\circ$ . If more discrete beams are needed, the number of antennas and the complexity of the Butler matrix increase rapidly.

Figure 4 shows the block diagram of a four element antenna array. Its architecture is based on a  $4 \times 4$  Butler matrix having an original topology adapted to millimeter-wave frequencies, which avoids any cross-line. The four patch antennas are connected to a multiport circuit having four inputs and four outputs. This circuit is composed of four  $90^\circ$  hybrid couplers and two  $45^\circ$  phase shifters, implemented using  $\lambda g/8$  transmission lines. Due to their small dimensions, the patch antennas are integrated on the same substrate.

For each multiport output signal ( $b_5$ – $b_8$ ), an individual maximum is obtained by shifting the angle of arrival in the  $180^\circ$  range. The side-lobes are at least 8 dB below the main lobe and the angles of arrival corresponding to maximum signals are around  $-45^\circ$ ,  $-15^\circ$ ,  $15^\circ$ , and  $45^\circ$ . Therefore, the main lobe of the antenna array can be shifted by  $30^\circ$  multiplies. A gain of around 10 dBi can be obtained using this multiport antenna array [11].

#### 4. Proposed Transceiver Architectures

UWB technologies using short-pulse signals have been applied to radar systems since the 1960s, and their communication applications have stimulated industry and academia interest since 1990s. A network capacity of many hundreds of Mbps may be required by some specific applications such as WLAN Bridge for interconnecting Giga-Ethernet LANs, wireless virtual reality allowing free body movements, wireless TV high-resolution recording camera, or wireless Internet download of lengthy files. It is to be noted that, in addition to communication applications, the UWB devices can be used for imaging, measurements, sensors, and vehicle radars. In principle, there are two ways to achieve such a significant network capacity: (i) by increasing the spectral efficiency and/or (ii) by using an extended bandwidth.

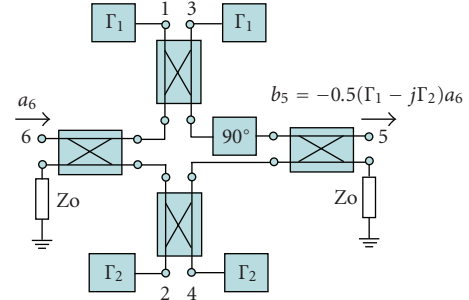

FIGURE 3: The simplified block diagram of a multiport modulator.

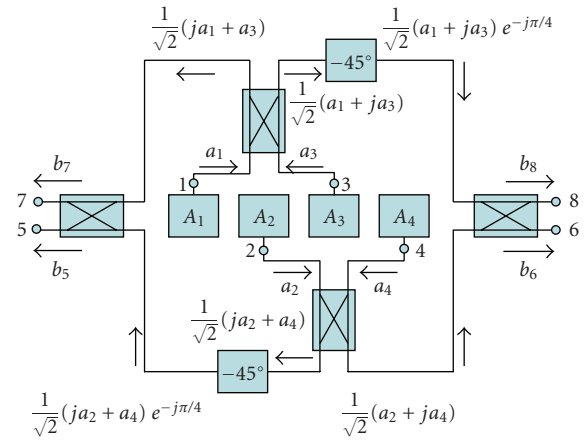

FIGURE 4: The simplified block diagram of a multiport antenna array.

According to FCC definition, the transmission bandwidth of UWB signals should be greater than 500 MHz or larger than 20% of the central frequency. This open definition does not specify any air interface or modulation for UWB. In the early stages, time-domain impulse radio (IR) has dominated UWB technology and still plays a crucial role. However, driven by the standardization activities, conventional modulation schemes, such as orthogonal frequency division multiplexing (OFDM) or single carrier (SC), have also appeared [3].

As known, the OFDM technique partitions a UWB channel to a group of nonselective narrowband channels (using a simple modulation technique such as QPSK), which makes it robust against large delay spreads, by preserving orthogonality in the frequency domain. In order to meet at least the “500 MHz requirement” of the UWB systems, two approaches can be used: (i) a high number of carriers (16, 32, 64, or 128) with a corresponding relatively low bit-rate/carrier, or (ii) a small number of carriers (2, 4, or 8) with a corresponding higher bit-rate/carrier. However, at 60 GHz, phase noise and carrier offset will degrade the OFDM performances. Due to the complexity of the OFDM architecture, in our opinion, only the second approach can be suitable for low-cost 60 GHz UWB WLANs.

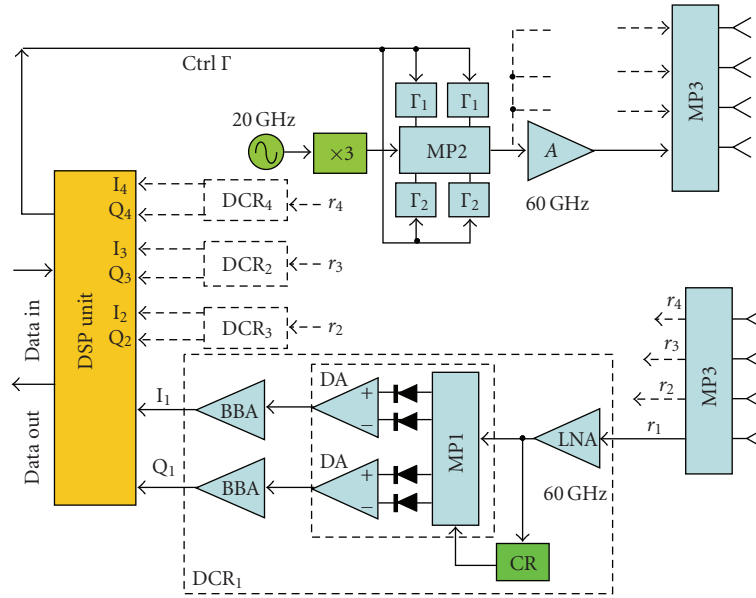

FIGURE 5: The simplified block diagram of a multiport direct conversion transceiver.

The available bandwidth, the efficient reuse of spectrum (due to strong signal attenuation at 60 GHz) makes flexibility, simplicity, and cost the most critical points. It was demonstrated that transmissions using SC advanced modulation techniques and directive antennas can achieve comparable performances with OFDM for a 60 GHz indoor channel [3]. These modulations, such as  $M$ -ary quadrature amplitude modulation (QAM) and  $M$ -ary phase shift keying (PSK), will increase the spectral efficiency. Simulations of a 60 GHz high-speed multiport heterodyne receiver have been recently published [5]. A bit-rate up to 400 Mbps has been achieved using a 16 QAM modulation for an IF of 900 MHz. The proposed architecture enables the design of compact and low-cost wireless millimeter-wave communication receivers for future high-speed WLANs, according to the IEEE 802.15.3c standard. However, the millimeter-wave circuits' bandwidth must be increased to few GHz and the IF must be at least 2.45 GHz, to cope with Gb/s bit-rates.

In order to use such a modulation, a UWB transmitter must be also designed. In the case of SC-AM, the use of the directive antenna arrays based on multiports, of the heterodyne multiport I/Q down-converter, and of the multiport modulator, is considered as very promising for indoor low-cost UWB communications.

Figure 5 shows a simplified block diagram of a millimeter-wave multiport direct conversion transceiver. A multiple input multiple output (MIMO) architecture is proposed. Two-phased array based on Butler matrices are used. This solution appears optimal because few discrete beam directions are generally sufficient in indoor WLANs. A 20 GHz microwave oscillator and a frequency multiplier generate the 60 GHz signal. The DSP unit modulates the carrier using a multiport direct modulator MP2. According to 60 GHz proposed standard, the required amplifier output

power is +10 dBm. In order to obtain the control of transmitted beams, the DSP will activate one of millimeter-wave amplifiers to feed the transmitter multiport antenna array MP3. The corresponding direct conversion receiver (DCR<sub>*i*</sub>) is composed by a low-noise amplifier (LNA), a carrier recovery (CR) circuit, a multiport down-converter (MP1), power detectors and differential amplifiers (DA), and two baseband amplifiers (BBA).

The access to the inphase (I) and quadrature (Q) signals will enable significant additional capabilities, increasing the phase measurement accuracy and offering a straightforward correspondence between the baseband phasor rotation frequency and the Doppler shift if the same oscillator is used in the receiver part. The carrier recovery circuit is used as reference signal and will compensate the Doppler shift in a hardware approach.

Figure 6 shows the proposed heterodyne architecture of a multiport transceiver. Due to the increased gain of the receiver, omnidirectional antennas can be also used. An additional millimeter-wave oscillator must be used in the receiver part due to the nonzero IF. The Doppler effects and the inherent frequency shift between millimeter-wave oscillators are compensated using a PLL circuit operating at IF. The second down-conversion can use conventional means due to the microwave operating frequency. To cope with data rates of 500 Mbps, the IF of the heterodyne receiver is chosen at 900 MHz. If the data rate is increased to 1 Gb/s, the IF can be chosen at 2.45 GHz.

Direct Sequence (DS) UWB is often referred to as impulse, baseband, or zero carrier technique. It operates by sending Gaussian low-power-shaped pulses, coherently received by the receiver. In view of the fact that the system operates using pulses, the transmission spreads out over a wide bandwidth, typically many hundreds of MHz or even several GHz. To enable data to be carried, DS UWB

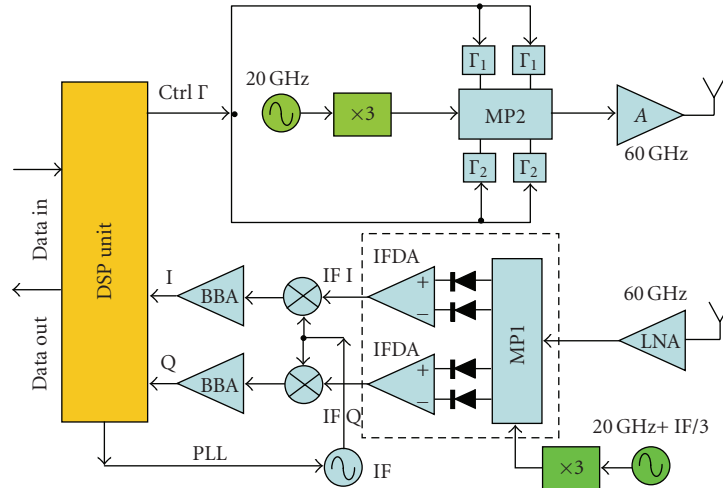

FIGURE 6: The simplified block diagram of a multiport heterodyne transceiver.

transmissions can be modulated in multiple ways. For example, pulse position modulation (PPM) encodes the information by modifying the time interval and, hence, the position of the pulses; binary phase shift keying (BPSK) reverses the phase of the pulse to signify the data to be transmitted.

Therefore, in order to use a larger bandwidth with reduced power consumption, a new method based on the transposition of impulse radio ultra wideband (IR UWB) signals at 60 GHz-band can also be taken into account [12–14].

As a low-cost 60 GHz IR UWB proposal, the transmitter part can be implemented using an oscillator, a millimeter-wave switch and an amplifier. A pulse generator (1st PG) generates subnanoseconds pulses (e.g., pulse width around 350 ps, in order to reach 3 GHz bandwidth). The 60 GHz carrier will be digitally pulse position modulated (PPM) using a millimeter-wave switch. After amplification, Gaussian pulses are emitted over several GHz bandwidth centered into the 60 GHz band. In order to implement the receiver, either a mixer or a detector can be used. If a mixer is used, a millimeter-wave oscillator is needed. The mixer can be implemented using the low-cost, low-power consumption multiport down-converter. The oscillator is not required when a topology with a detector is chosen, as presented in Figure 7. Therefore, the receiver is composed of three main modules: a low-noise amplifier, a 60 GHz detector, and a correlator. A pulse generator (2nd PG) is used to control the sample and hold (S/H) circuit. The main advantage of this architecture is that no phase information is needed, and thus, no sophisticated coherent stable sources or carrier recovery circuits are involved. It is to be noted that the pulses can also be modulated using the BPSK with minimal architectural changes in both transmitter and receiver. In order to transmit data information, instead of modifying the position of pulses as for PPM, the phase of subnanosecond pulses will be reversed at the transmitter. The receiver must be able to observe these 180° phase changes; therefore, a multiport based phase-detector can be successfully used. It

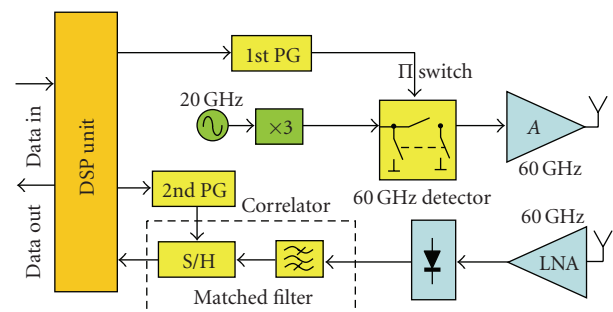

FIGURE 7: The simplified block diagram of an impulse-radio transceiver.

is to be noted that in the block diagrams, the DSP include required A/D and D/A converters.

Transmission on ranges up to 10 meters can be expected, due to the high free-space loss at the carrier frequency. The Friis path loss equation shows that, for equal antenna gains, path loss increases with the square of the carrier frequency. Therefore, 60 GHz communications have an additional 22 dB of path loss when compared to an equivalent 5 GHz system. However, antenna dimensions are inversely proportional to carrier frequency. Therefore, more antennas can be placed within a fixed area and the resulting antenna array will improve the overall antenna gain. The directive antenna pattern of a beam forming antenna array improves the channel multipath profile by limiting the spatial extent of the transmitting and receiving antenna patterns to the dominant transmission path. This aspect opens up new opportunities for wireless system design. The use of smart antennas will also improve the link budget and will reduce the transmitter power.

A consequence of the confinement to smaller cells is that the channel dispersion is smaller than the values encountered at lower frequencies because echo paths are shorter on average. However, movements of the portable stations, as well as the movement of objects in the environment, cause

Doppler effects, relatively severe at 60 GHz, because they are proportional to the carrier frequency. For example, if persons move at a walking speed of 1.5 mps, the Doppler spread result is 1200 Hz.

Simulated BER results are excellent. The BER values are less than  $10^{-5}$  for energy per bit to noise power spectral density (Eb/No) ratio of 10 dB [11]. These results prove that simple multiport architectures can be suitable for low-cost millimeter-wave transceivers for future 60 GHz WLANs.

## 5. Conclusion

Several millimeter-wave multiport transceiver architectures have been presented in this paper. The millimeter-wave frequency conversion is obtained using the proposed I/Q multiport down-converter, avoiding the use of a costly active mixer or a high-power millimeter-wave LO (in the case of the conventional diode mixers). A multiport direct modulator or a millimeter-wave switching network can be used to modulate the millimeter-wave carrier. In addition, an antenna array based on a multiport circuit provides four output signals corresponding to four optimal directions of arrival.

The proposed multiport architectures enable the design of compact and low-cost wireless millimeter-wave transceivers for future UWB wireless communication systems.

## Acknowledgments

The financial support of the National Science Engineering Research Council (NSERC) of Canada is gratefully accepted.

## References

- [1] P. Smulders, "Exploiting the 60 GHz band for local wireless multimedia access: prospects and future directions," *IEEE Communications Magazine*, vol. 40, no. 1, pp. 140–147, 2002.
- [2] D. Cabric, M. S. W. Chen, D. A. Sobel, S. Wang, J. Yang, and R. W. Brodersen, "Novel radio architectures for UWB, 60 GHz, and cognitive wireless systems," *EURASIP Journal on Wireless Communications and Networking*, vol. 2006, Article ID 17957, 18 pages, 2006.
- [3] C. Park and T. S. Rappaport, "Short-range wireless communications for next-generation networks: UWB 60 GHz millimeter-wave WPAN, and ZigBee," *IEEE Wireless Communications*, vol. 14, no. 4, pp. 70–78, 2007.
- [4] S. O. Tatu, E. Moldovan, K. Wu, R. G. Bosisio, and T. A. Denidni, "Ka-band analog front-end for software-defined direct conversion receiver," *IEEE Transactions on Microwave Theory and Techniques*, vol. 53, no. 9, pp. 2768–2776, 2005.
- [5] S. O. Tatu and E. Moldovan, "V-band multiport heterodyne receiver for high-speed communication systems," *EURASIP Journal on Wireless Communications and Networking*, vol. 2007, Article ID 34358, 7 pages, 2007.
- [6] D. Hammou, N. Khaddaj Mallat, E. Moldovan, S. Affes, K. Wu, and S. O. Tatu, "V-band six-port down-conversion techniques," in *Proceedings of the International Symposium on Signals, Systems and Electronics (ISSSE '07)*, pp. 379–382, Montreal, Canada, July-August 2007.
- [7] B. Boukari, E. Moldovan, S. Affes, K. Wu, R. G. Bosisio, and S. O. Tatu, "A low-cost millimeter-wave six-port double-balanced mixer," in *Proceedings of the International Symposium on Signals, Systems and Electronics (ISSSE '07)*, pp. 513–516, Montreal, Canada, July-August 2007.
- [8] R. G. Bosisio, Y. Y. Zhao, X. Y. Xu, et al., "New wave radio," *IEEE Microwave Magazine*, vol. 9, no. 1, pp. 89–100, 2008.
- [9] K. M. K. H. Leong and T. Itoh, "Advanced and intelligent RF front-end technology," in *Proceedings of the IEEE Topical Conference on Wireless Communication Technology (WCT '03)*, pp. 190–193, Honolulu, Hawaii, USA, October 2003.
- [10] J.-Y. Park, S.-S. Jeon, Y. Wang, and T. Itoh, "Integrated antenna with direct conversion circuitry for broad-band millimeter-wave communications," *IEEE Transactions on Microwave Theory and Techniques*, vol. 51, no. 5, pp. 1482–1488, 2003.
- [11] E. Moldovan, S. O. Tatu, and S. Affes, "A 60 GHz multi-port front-end architecture with integrated phased antenna array," *Microwave and Optical Technology Letters*, vol. 50, no. 5, pp. 1371–1376, 2008.
- [12] M. Devulder, N. Deparis, I. Telliez, et al., "60 GHz UWB transmitter for use in WLAN communication," in *Proceedings of the International Symposium on Signals, Systems and Electronics (ISSSE '07)*, pp. 371–374, Montreal, Canada, July-August 2007.
- [13] N. Deparis, A. Boé, C. Loyez, N. Rolland, and P.-A. Rolland, "UWB-IR transceiver for millimeter wave WLAN," in *Proceedings of the 32nd Annual Conference on IEEE Industrial Electronics (IECON '06)*, pp. 4785–4789, Paris, France, November 2006.
- [14] N. Deparis, A. Bendjabballah, A. Boe, et al., "Transposition of a baseband UWB signal at 60 GHz for high data rate indoor WLAN," *IEEE Microwave and Wireless Components Letters*, vol. 15, no. 10, pp. 609–611, 2005.



**Hindawi**

Submit your manuscripts at  
<http://www.hindawi.com>

