



Durham E-Theses

*The status, distribution, and diet of the badger (*meles meles L*) in an area to the south of Durham city*

Moore, G. F.

How to cite:

Moore, G. F. (1977) *The status, distribution, and diet of the badger (*meles meles L*) in an area to the south of Durham city*, Durham theses, Durham University. Available at Durham E-Theses Online:
<http://etheses.dur.ac.uk/9152/>

Use policy

The full-text may be used and/or reproduced, and given to third parties in any format or medium, without prior permission or charge, for personal research or study, educational, or not-for-profit purposes provided that:

- a full bibliographic reference is made to the original source
- a [link](#) is made to the metadata record in Durham E-Theses
- the full-text is not changed in any way

The full-text must not be sold in any format or medium without the formal permission of the copyright holders.

Please consult the [full Durham E-Theses policy](#) for further details.

Academic Support Office, Durham University, University Office, Old Elvet, Durham DH1 3HP
e-mail: e-theses.admin@dur.ac.uk Tel: +44 0191 334 6107
<http://etheses.dur.ac.uk>

The copyright of this thesis rests with the author.
No quotation from it should be published without
his prior written consent and information derived
from it should be acknowledged.

THE STATUS, DISTRIBUTION, AND DIET OF THE BADGER (MELES
MELES L.) IN AN AREA TO THE SOUTH OF DURHAM CITY.

G.F.Moore .

July 1977 .



BADGER EMERGING FROM SETT "H6".

CONTENTS.

1.	INTRODUCTION.	1
2.	THE STUDY AREA.	4
3.	CENSUS.	
3.i.	METHODS.	8
3.ii.	RESULTS.	13
3.iii.	DISCUSSION.	19
4.	FACTORS CONTROLLING DISPERSION.	
4.i.	GENERAL INTRODUCTION.	21
4.ii.	PHYSICAL FACTORS.	
a.	Introduction.	23
b.	Methods.	27
c.	The Nature of the Sample.	29
d.	Statistical Methods.	30
e.	Results.	32
f.	Discussion.	45
4.iii.	SOCIAL FACTORS.	
a.	Introduction.	49
b.	Methods.	51
c.	Results.	56
d.	Discussion.	68
5.	DIET.	
5.i.	INTRODUCTION.	72
5.ii.	METHODS.	74
5.iii.	RESULTS.	78
5.iv.	DISCUSSION.	85
6.	DISCUSSION.	90
7.	SUMMARY.	102
8.	REFERENCES.	104

9.	ACKNOWLEDGMENTS.	110
APPENDIX 1.	METHODS USED IN THE 1968 AND 1971 SURVEYS.	111
APPENDIX 2.	RAW DATA USED IN THE ANALYSIS OF PHYSICAL FACTORS.	113
APPENDIX 3.	GRID REFERENCES AND MAPS GIVING THE POSITIONS OF ALL THE SETTS FOUND.	118
APPENDIX 4.	KEY FOR THE IDENTIFICATION OF EPI- DERMAL FRAGMENTS, INCLUDING PHOTO- MICROGRAPHS.	128
APPENDIX 5.	DATES OF COLLECTION AND CONTENTS OF THE SCATS COLLECTED.	143
APPENDIX 6.	THE 1974 MAMMAL SOCIETY DISTRIBUT- ION MAP OF THE BADGER.	148
APPENDIX 7.	HOME RANGE SIZES AND DIETS OF SOME MAMMALS, FROM MACNAB (1963) TABLE 1	149

PLATES.

Frontpiece.	BADGER EMERGING FROM SETT H6.	ii
3.1.	SETT UNOCCUPIED FOR SEVEN YEARS.	11
3.2.	SETT UNOCCUPIED FOR THREE YEARS.	11
3.3.	BREEDING SETT (DURHAM SCHOOL).	12

MAPS.

2.1.	THE STUDY AREA.	7
3.1.	SETTS ACTIVE IN 1968.	16
3.2.	SETTS ACTIVE IN 1971.	17
3.3.	SETTS ACTIVE IN 1975.	18
4.1.	THE RELATION OF DRIFT GEOLOGY TO SETT POSITION.	26
4.2.	THE PERCENTAGES OF CLAY PLUS SILT AT THE SETT SITES.	44

TABLES.

3.1.	THE NUMBERS OF SETTS AND POPULATION ESTIMATES.	15
4.1.	CONTINGENCY TABLES OF DATA USED IN THE ANALYSIS OF PHYSICAL FACTORS.	39
5.1.	NUMERICAL OCCURENCE OF ITEMS IN THE FAECES OF BADGERS.	80
5.2.	THE MONTHLY OCCURENCE OF ITEMS IN THE FAECES OF BADGERS.	81
5.3.	OCCURENCE OF FOOD ITEMS, COMPARED WITH NEAL'S (1948) DATA.	82
5.4.	ASSOCIATION INDICES AND PROBABILITIES FOR THE SPECIES PAIRS ON FIG. 5.1.	83

FIGURES.

4.1.	ASSOCIATIONS OF PHYSICAL FACTORS WITH SETT ACTIVITY.	36
4.2.	RELATIONSHIP OF SETT OCCUPATION WITH ASPECT.	37
4.3.	VARIABLES AFFECTING THE DEGREE OF SETT ACTIVITY.	38
4.4.	HISTOGRAMS OF NEAREST NEIGHBOUR DISTANCES (ACTIVE AND BREEDING)	59
4.5.	DENDROGRAM OF 1975 ACTIVE AND VISITED SETTS.	60
4.6.	DENDROGRAM OF 1971 ACTIVE AND VISITED SETTS.	61
4.7.	DENDROGRAM OF 1968 ACTIVE AND VISITED SETTS.	62
4.8.	THE FIRST FIVE MEAN NEAR NEIGHBOUR DISTANCES FOR 1975, 1971 AND 1968.	63
4.9.	TYPE ONE RANDOM DISTANCES, COMPARED WITH 1975 OBSERVED DISTANCES.	64
4.10.	TYPE TWO RANDOM DISTANCES, COMPARED WITH 1975 OBSERVED DISTANCES.	65
4.11.	TYPE ONE RANDOM DISTANCES, COMPARED WITH 1971 OBSERVED DISTANCES.	66
4.12.	TYPE ONE RANDOM DISTANCES, COMPARED WITH 1968 OBSERVED DISTANCES.	67
5.1.	ASSOCIATION MATRIX OF ITEMS FOUND IN THE FAECES OF BADGERS.	84

The badger is Britain's largest extant terrestrial carnivore, the adults being approximately 900 mm. in length, including a tail of 100 mm. The average adult male weight is 12 kg. and the average adult female weighs 11 kg. (Southern, 1964, from a sample of 50 animals). Badgers are widely distributed through Britain and Ireland, being most common in the west country and northern England, and least common in East Anglia and Scotland. However the lack of badgers in Scotland may be due to the shortage of observers. The setts are found in a variety of places, a preference being shown for slopes, typically in woods or copses which border pasture-land. The badger is mainly crepuscular and nocturnal, and remains in the sett in daylight, except perhaps in remote areas. The badgers' habits make study difficult without such aids as image intensifiers and radio-telemetry. There is only one published study, which used radio-telemetry; this is Bonnin-Lafague and Canivenc(1961), who studied the activity of a single sow. The badger as is typical for carnivores, possesses scent glands and in particular, being a mustelid, well developed musk glands. These are important in the animal's social behavior. The badger is an omnivore, feeding on such material as earth-worms, small mammals, birds, insects, various fleshy plants, acorns and corn. Of these, earth-worms are considered the most important (Southern, 1964; Neal, 1948).

The present study considers the population, breeding status, the factors affecting the dispersion of the setts, and the diet of badger. There have been two previous studies on the badger in the same area as the present study, carried out during the late springs

of 1968 and 1971. Both of these were undergraduate research projects, the first by Stirling and Harper (1969), and the second by Burgess, Alexander and Bates (unpublished). These studies suggested that the area supported a density of approximately six badgers (adults and cubs per km²). This density is higher than that quoted in the literature for similarly favourable, by for example Neal (1965). However a similar density is reported in Wytham Wood near Oxford (H.Kruuk, pers. comm.). Brief details of the badger setts in this area have been given by Southern (1964, p. 66 & 67).

The dispersion of the setts is considered in relation to the physical and social factors affecting the choice of sett site. The physical factors are considered first in order to determine those areas suitable for sett sites. In the light of evidence from the analysis of the physical factors, the spatial patterning of the setts is examined, so as to give an indication of the badger's social behaviour.

There have been several studies of the diet of the badger in outline, by the examination of stomach contents and by the examination of macroscopic remains in faeces. The object of the present study was to determine the diet over the summer months, by the examination of such microscopic remains as hair, feathers and fragments of the epidermis of plants. It was intended that such data could be interpreted in terms of more long term and extensive, though less detailed, studies of macroscopic remains.

There has been concern shown over a decline, in recent years, of badger numbers in parts of Britain, reported for example by Jeffries (1965). This concern has resulted in the "Badgers Act, 1973". Neal (1965) considered that the decline in badger numbers

was due to the following factors: increase in road traffic density, third rail electrification of railways (mostly in the Southern Region of British Rail), the change from deciduous to coniferous woodland, and changes in agricultural practice, particularly the destruction of hedges and copses, and the use of such insecticides as organo-mercury seed dressings. In the study area being considered only one of these factors is operating, the use of organo-mercury seed dressings, and in fact traffic density on the A167 (to the east of the study area, see Map 2.1) has dropped substantially since the completion of the A1 motorway, which passes to the east of Durham. This motorway was completed in the mid 1960's. Thus the status of the badger in this area is of interest in relation to the badger's conservation, since one would expect the numbers to have remained steady, within the limits of normal population fluctuation, if only those factors named by Neal (1965) are responsible for the decline elsewhere in the country.

Map 2.1 shows the study area and the overlay to this map shows the drift geology. The study area is approximately five Km² in area. It is bounded to the east and south by meanders of the River Wear, to the west by the A167 and to the north by Durham City. The overlay gives the sources of the geological information¹. Since much of this information is taken from 1" Ordnance Survey maps, small scale local variations in the nature of the drift are not shown, this being less homogenous than is apparent from the overlay. The boulder clay is quite sandy in places, there being small patches of fluvio-glacial sand within it. The pattern of drift geology results from the River Wear in post-glacial times cutting through an original drift of boulder clay overlying fluvio-glacial sand. The river has more recently given rise to deposits of alluvium and gravel, to form a flood plain where it has cut into the drift deposits. The river is now contained by earthen banks. The resulting soils are loams of varying sandiness.

The use to which the land within the study area is put is dependent inter alia on the nature of the soil, the degree and aspect of the slope, the water table, and the closeness to the city. There are four categories of land utilisation within the study area: woodland, mixed agricultural land, permanent grassland and buildings. The woodland is mostly deciduous, though there are some small stands of conifers, planted about 30 years ago. The bulk of the woodland lies on fluvio-glacial sand, and is situated along the river bluff. The agricultural land consists of approximately equal areas of arable and of pasture-land. The arable land lies mostly on the

1. The atlas of Durham City referred to is by Bowen-Jones (1970).

alluvium and the river terrace gravel, and the pasture-land mostly on the boulder clay. The permanent grassland consists of the grounds of the colleges, university and Durham School, and of a golf course.

The area contains a range of habitats suitable for badgers. The woodland provides extensive slopes into which setts can be dug. Sites for setts are also provided by banks at the sides of fields and by the earthen river bank. Several other banks have been created by earth moving, e.g. at Durham School (north-west corner of map 2.1) and by an old wagonway, which runs from Pinnock Hill (bottom of square 27,40 on map 2.1) east-north-east to the river. The wagonway has an average height of four metres, and consists of a mixture of earth and slag.

This range of habitats makes the area suitable for the analysis of the effect of environment on the dispersion of badgers, since there exists a choice of habitats in an area small enough to be studied on foot. The density is high enough for an analysis of the spatial arrangement to be practicable. Interpretation is aided because the population is to some extent isolated; the River Wear, the built up area, and the A167 presenting barriers to the movement of badgers. The A167 acts as a barrier because of the traffic density and additionally because it traverses an area, which is relatively unsuitable for the location of badger setts.

The main areas where setts are present are indicated on map 2.1, being underlined to distinguish them from other place names. Three individual setts are marked on the map, H6, RB8 and RB9. The latter two are the river bank setts that do not lie within a strip 20 m. from the River Wear. H6 is marked because it is referred to in the analysis of diet. The sett groups will be referred to in the

text as follows:

MC = Maiden Castle

GH = Great High Wood

H = Hollingside Wood

WW = Wagonway

PH = Pinnock Hill

BW = Blaid's Wood

SG = Saltwell Gill

RB = River Bank

LB = Low Burnhall

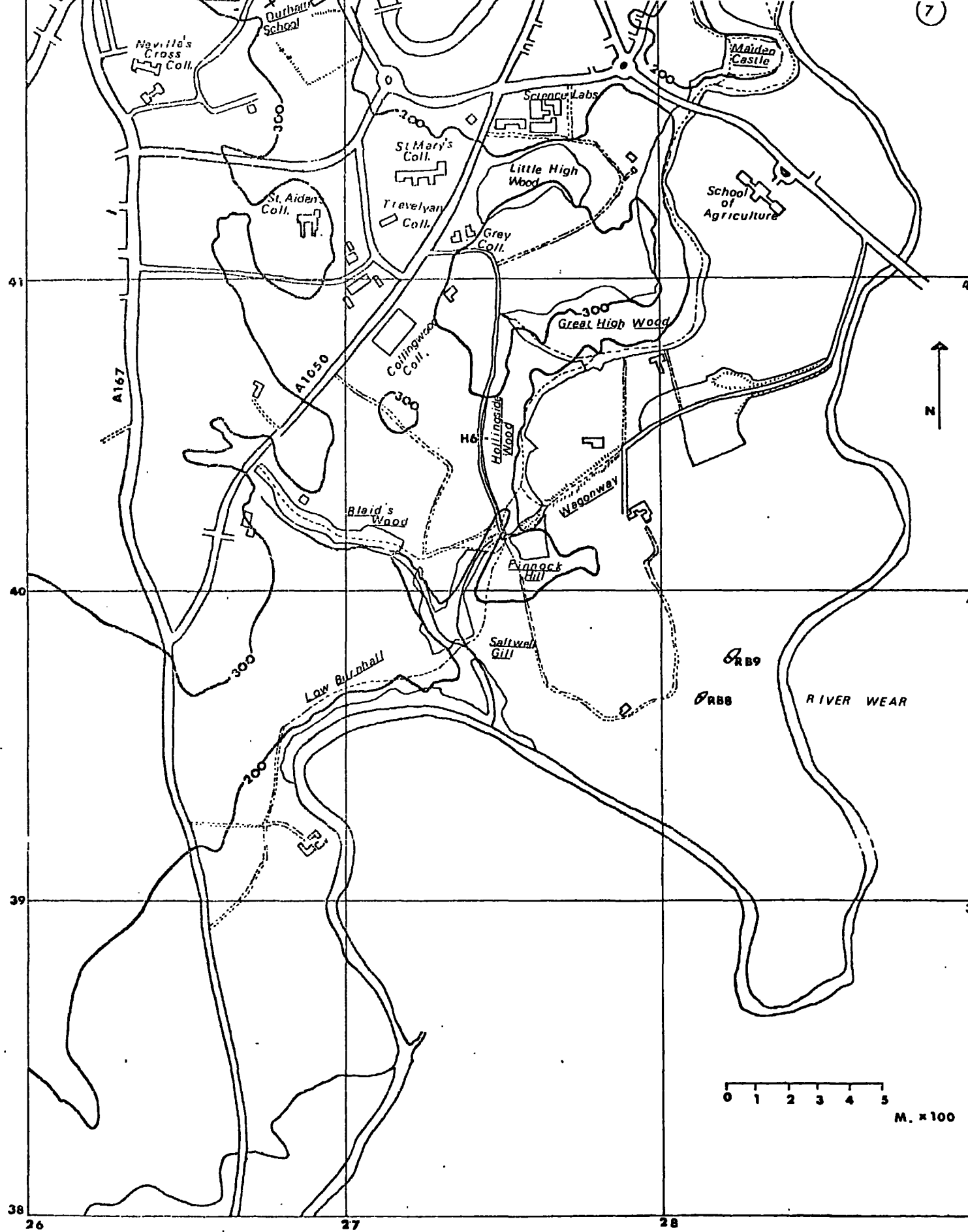





Grid Square NZ
 Scale 1:13,900
 Contours in Ft.

MAP 2.1

THE STUDY AREA

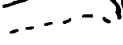
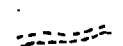
The Names of the Main Sett Locations are Underlined>.

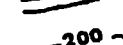
KEY :-

-  Stream
-  Path
-  Track
-  Road
-  200 Contour
-  Sett

METHODS.

Since it was intended to use the data from the census for an analysis of the spatial pattern of the setts, it was necessary to define a sett more precisely than was done in the surveys of 1968 and 1971, details of which are given in Appendix 1. In the present survey a sett was regarded as being distinct from a neighbouring sett if the distance between the two nearest entrance holes was greater than ten metres. The figure of ten metres was arbitrary; however if some of the tunnels between setts exceeded this length, the only effect would have been a marginal reduction in the number of unoccupied setts found. No assumption is made as to any social interactions between the setts.

The location of the setts in the part of the study area to the east of the A167 and the A1050 (see map 2.1) was by a systematic search. Due to the large amount of private property, it was no possible to search the part of the study area in the triangle of land between the A167 and the A1050 systematically, but this was in any case unnecessary in the case of the centre of the golf course. The longer slopes of the study area were searched by making parallel horizontal transects, and the shorter slopes by walking along their bases. The great High Wood, Hollingside Wood, Maiden Castle and the sloping areas of Blaid's Wood were searched by the former method; the Wagonway, parts of Blaid's Wood, Low Burnhall and field boundaries were searched by the latter method. The results of this survey were compared with those of the 1971 survey, and a more careful search was made if any sett seemed to have disappeared in the interim.

The following information was recorded for each sett; its position, level of activity and aspect to the nearest 10° of compass. The position was determined by one of the following methods: triangulation from landmarks, measurement from a point marked on the map, and by eye from the position of other setts and the appearance of the terrain, compared with contour details. The map used was a 1:10,580 Ordnance Survey map, enlarged to a scale of 1:6,500. Where possible the positions of the setts were recorded to the nearest 10 m.. This degree of accuracy may not have been reached in the river bank setts owing to the lack of nearby landmarks. The distance between any pair of setts was measured on the ground if it was less than 100 m.. The level of activity was gauged from such signs as the presence of either footprints, recently used latrines or both, and the amount of leaf litter in the entrance holes. Plates 3.1 to 3.3 show examples of setts in various states of usage. Plate 3.1 shows a sett near Durham School which has been inactive for seven years (R.Peale, pers. comm.). Plate 3.2 shows the sett at the vet's house which has been inactive for three years (R.Peale, pers. comm.). Plate 3.3 shows a breeding sett in the grounds of Durham School. For the locations of these setts see the north-west corner of map 2.1.

The setts found to be inactive in the initial survey were not investigated further. Those setts remaining, about 50% of the total, were further investigated by placing crossed sticks in their entrance holes and noting if these sticks had been disturbed. Badgers are known to visit setts ^{next} their home base without necessarily occupying them (Neal, 1948). Hence those setts in which the crossed sticks had been disturbed were investigated by direct

observation. Each of them was watched for one night, and if badgers were not seen they were watched for a subsequent night. A note was taken of the number of all adults and cubs seen, so as to enable a minimum population estimate to be made.

The population size was estimated by adding to the number seen an arbitrary estimate of one and a half per sett for setts where badgers were heard, but there was no definite sighting. This was only necessary for two setts, MC8 and MC6.

From the information obtained the setts were assigned to one of four activity classes. Where there was any doubt as to the correct class the lower of the classes was assumed. The classes are listed below.

CLASS ONE	Unoccupied (no signs of activity)
CLASS TWO	Visited (signs of badgers nearby, crossed sticks disturbed, but no badgers seen)
CLASS THREE	Occupied (badgers seen to emerge from the sett, but no cubs seen)
CLASS FOUR	Breeding (both adults and cubs present)



Plate 3.1: This sett had been unoccupied for
seven years.



Plate 3.2: The sett in the vet's garden; this had
been unoccupied for three years.



plate 3.3: The sett in Durham School; this was
a breeding sett.

3.ii.

RESULTS.

Table 3.1 summarises the results of the 1968, 1971 and 1975 surveys. Maps 3.1, 3.2 and 3.3 show the positions of the visited, occupied and breeding setts for the 1968, 1971 and 1975 surveys respectively. Appendix 3 gives a table of the grid references and activity classes of all the setts found in the three surveys. The positions of these setts are also shown on a map of the same scale as that used for the present survey. The positions of any setts that had disappeared by the time of the present survey have been estimated from the Six inch ordnance Survey maps used in the previous surveys.

In the present study six new setts were found. Two of these were occupied, BW3 and LB4. BW3 was a recent excavation in the same area as a large sett that was destroyed during the 1968 survey. LB4 was a new excavation 20 m. from an established sett (LB3), and may be a newly excavated entrance for LB3, due to cattle trampling near to the present entrance of LB3. The four other new setts were small single hole excavations, and may have been only exploratory in nature.

The figures obtained from direct observation should be interpreted with regard to the following sources of error: the setts were only watched for a short time, hence the number of active setts may be an underestimate; the number of breeding setts is likely to be an underestimate, since at some setts it was difficult to get a good sighting of the badgers so as to determine whether or not any cubs were present; and the period during which direct observations were made covered only a period of approximately

one month furthermore there may have been changes in sett occupation during this time.

The minimum population estimate in 1975 was 28, including 8 cubs. The estimate referred to as the "crossed sticks estimate", in table 3.1b, is the number of entrance holes where crossed sticks were disturbed, divided by two. This is a somewhat unreliable method of estimating badger populations, and is given solely to enable a comparison with the 1971 figures to be made.

TABLE 3.1.

THE NUMBERS OF SETTS AND POPULATION ESTIMATES OF BADGERS IN 1968, 1971 AND 1975.

a) The numbers of setts falling into each class of activity.

YEAR	(1) UNOCCUPIED	(2) VISITED	(3) OCCUPIED	(4) BREEDING	FOX/RABBIT	TOTAL
1968*	19	11	5	3	4	42
1971	47	7	15 ⁺		2	71
1975	39	10	8	3	9	69

*The published figure (Stirling & Harper, 1969) is 15 unoccupied setts. However, as judged from maps supplied by Miss Harper, the count is 19. Some groups of setts, as defined in the present survey, were considered as single setts in this survey. See Appendix 1 for details.

⁺Breeding and active setts, as defined in the methods, were not distinguished in this survey.

b) The population estimates.

YEAR	MINIMUM*	CROSSED-STICKS ⁺ ESTIMATE	CUBS OBSERVED
1968	29	-	7
1971	-	31	-
1975	28	32	8

* Adults and cubs.

⁺See page 14 for the derivation of this estimate.

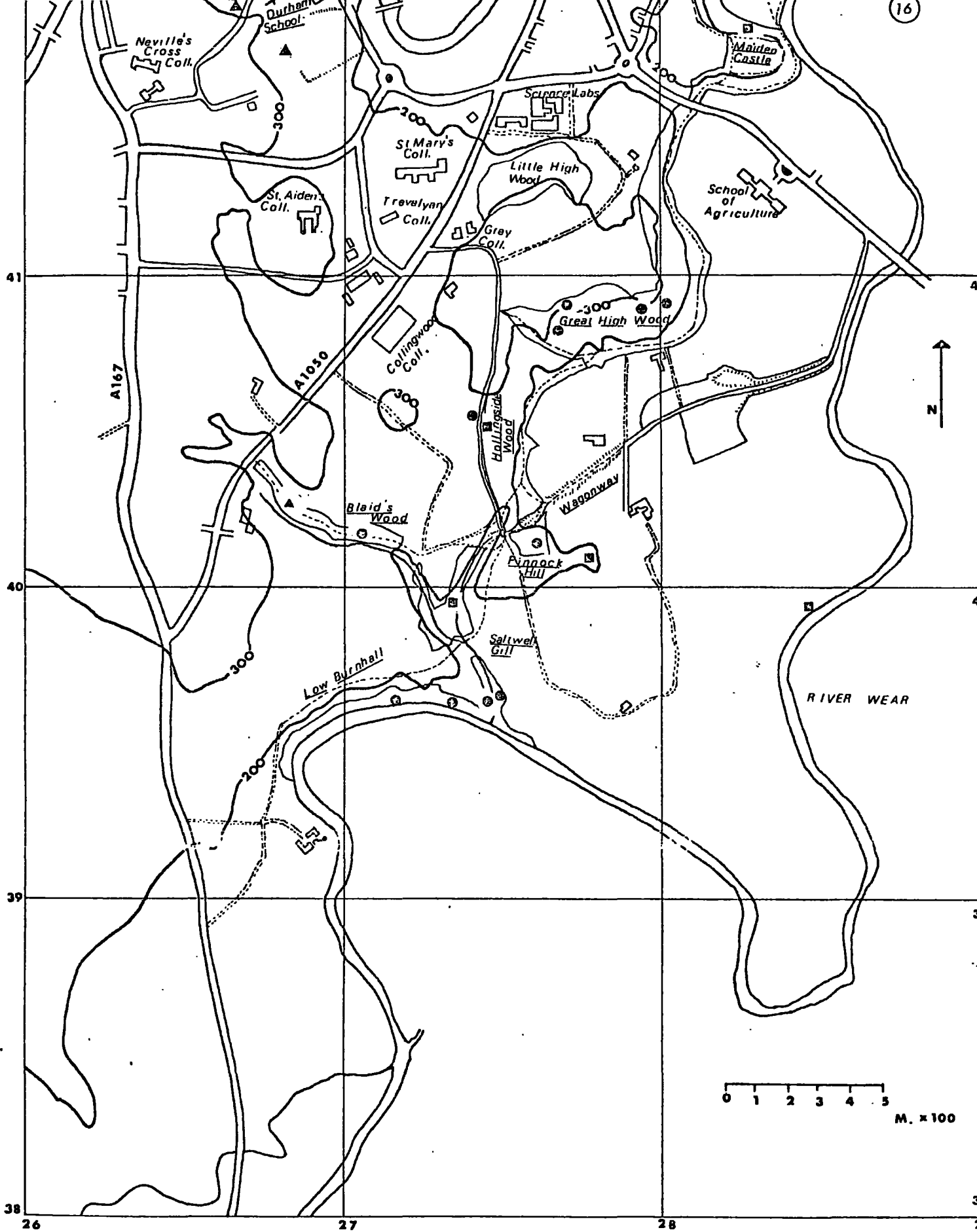

Grid Square NZ
 Scale 1:15,900
 Contours in Ft.

Setts Active in 1968

MAP 3.1

- ▲ BREEDING
- ACTIVE
- ACTIVE?

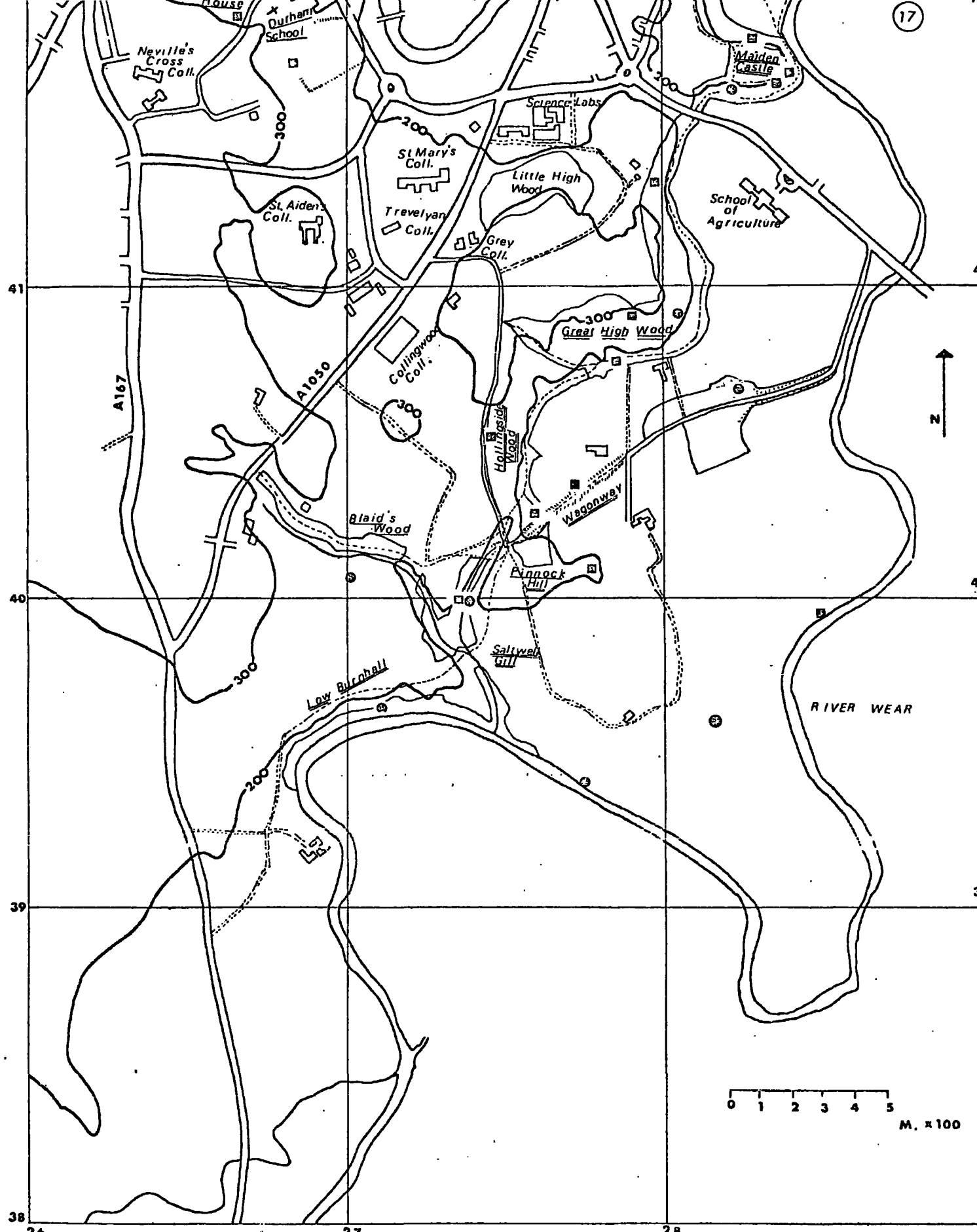

Grid Square NZ
 Scale 1:15,900
 Contours in Ft.

Setts Active in 1971

MAP 3.2

-  BREEDING
 ACTIVE
-  ACTIVE?

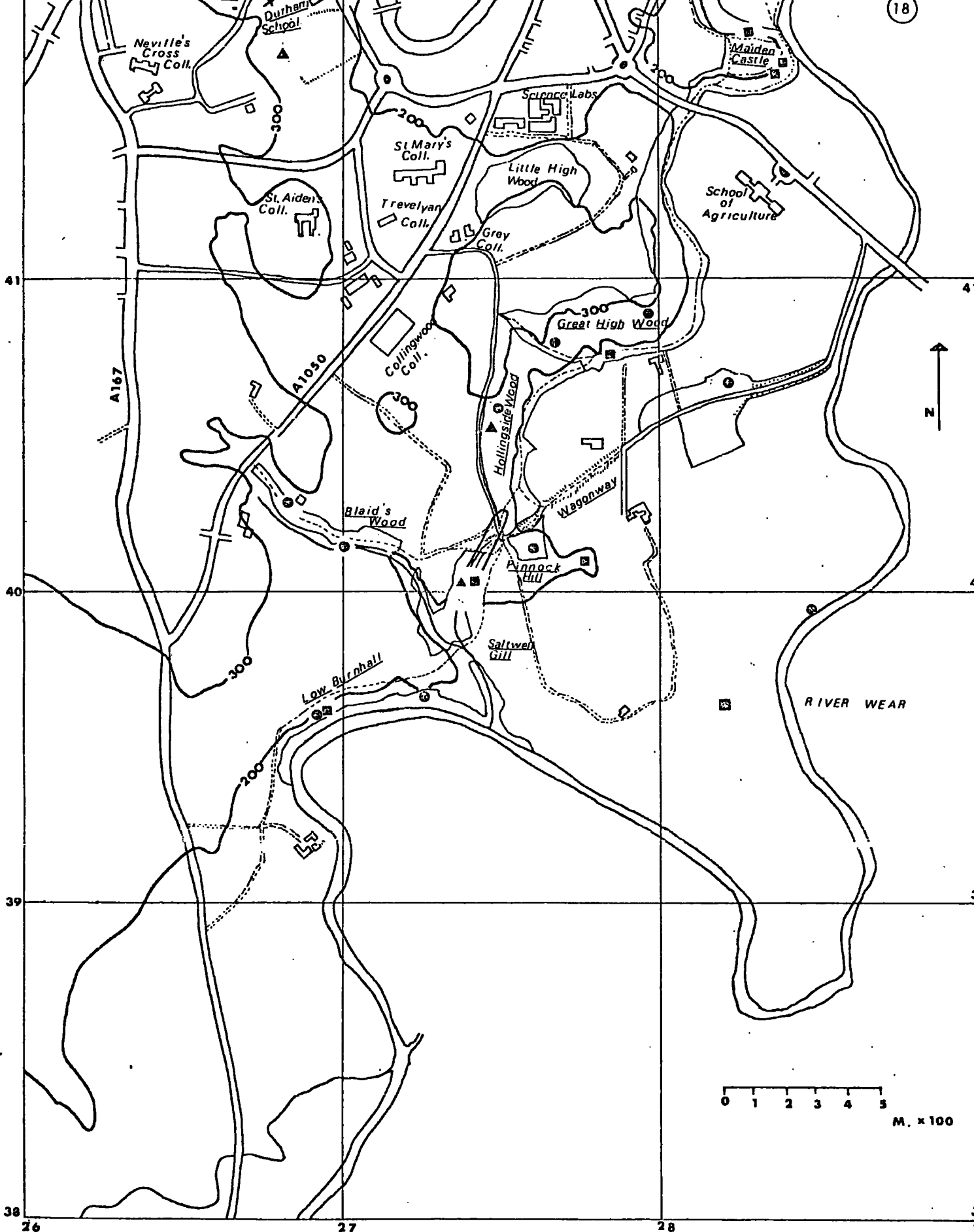

Grid Square NZ
 Scale 1:15,900
 Contours in Ft.

Setts Active in 1975

MAP 3.3

- ▲ BREEDING
- ACTIVE
- ⊙ ACTIVE?

3.iii.

DISCUSSION.

The observed density of setts, in the study area, is 12 per km². Densities in other well populated areas, recorded in Ministry of Agriculture surveys (R.Symes, pers. comm.), are around five per km²; near Thornbury (Glos.) 450 setts were found in an area of 40 square miles, corresponding to a density of 4.3 setts per km²; at Wootton under Edge (Stroud, Glos.) 1038 setts were found in an area of 64 square miles, corresponding to a density of 6.3 setts per km². Densities are much lower in eastern England. For example Allen and Cowlin (1971) in a study of S.W. Essex found 112 setts in 600 km², corresponding to a density of 0.19 per km². The figures found in the present and previous surveys are greater than these. However, locally in the Thornbury area, the density reached 22 per km² (R.Symes, pers. comm.). Thus the present area has a density of setts which is high, suggesting that the study area is favourable to badgers, but not unusually so.

The minimum population estimate was 28 (including cubs), but the number present could have been as high as 35 if all the active setts had at least two badgers present. This figure corresponds to a density of six badgers per km². This is higher than some population estimates for areas favourable to badgers. For example Neal (1948) quotes a figure of 1.2 per km², which is lower than that observed in the present study; however a density of eight per km² has been observed in Wytham Wood, near Oxford (H.Kruuk, pers. comm.), and densities in the range 7 to 25 per km² have been observed at Woodchester Valley in the Cotswolds (Glos.), (A.Cheeseman, pers. comm.).

The population figure has not changed in the three surveys,

within the limits of error of population estimation; further, the same number of cubs were found in both the 1968 (Stirling & Harper, 1969), and the present surveys. Thus one may conclude that this is a stable population. Hence the present study does not indicate that any factors need be added to Neal's (1965) list of factors responsible for the decline in badger numbers (see p. 2). It can further be concluded that any mortality caused in this study area, by organo-mercury seed dressings, is not such as to cause a decline in numbers.

The only change that has occurred is an increase in the number of setts recorded in the area. This could be due to a change in the distribution of badgers, or to an increased efficiency in the detection of setts. There has definitely an increase in digging in the wagonway area since 1968 (K.R.Ashby, pers. comm.). Only a total of 20 setts have been active in during all three surveys, as compared with an average of 11 active setts in any one year. Thus it is probable that the increase in the number of setts recorded was at least partly due to greater digging. Increased detection might have played some part in those areas where the terrain made search difficult.

It is difficult to provide any explanation for the changes in the pattern of occupation within those setts that had been occupied at any time during all three Surveys. It is possible that the changes may have reflected a change in the organisation of badger "families"; the causes of this reorganisation could have been interference e.g. the gassing of the Blaid's Wood sett (BW3, BW4 & BW5), or a change in available food. Hence the changes in sett occupation will be discussed further (see section 6, p. 97) in the light of evidence from subsequent sections.

4.i FACTORS CONTROLLING DISPERSION

GENERAL INTRODUCTION.

The distribution of animals can be limited by one or more of the following: interspecific interactions and intraspecific interactions. Watson & Moss (1969) discuss these factors with reference to vertebrate populations. An example of the limiting effects of intraspecific factors is Krebs' (1971) study of Great and Blue Tit populations in Wytham Wood near Oxford. Krebs (1971) found that the Great Tit population was limited by the number of territories available. The intraspecific factor in this case was agonistic behaviour. The interaction between limiting factors was demonstrated by the fact that artificial winter feeding increased the number of Blue Tit territories, but not of Great Tit territories. Examples of interactions between two species are given by Grant (1972) in a review of competition in rodents. In any particular study several factors are likely to be operating in a complex manner, as is illustrated in Krebs' (1971) study.

It was decided to investigate whether the setts which were unused had this status by reason of being unsuitable for occupation, and were only exploratory diggings, or if this status was caused by social behaviour. An analysis of physical factors was undertaken to determine the differences between the sites of used and unused setts. This limited aim was adopted because a study of the factors which enable badgers to exist in an area would have necessitated a control group of sites in areas where badgers were not present and the collection of this data from a number of "random-sites". This would not have been possible within the time allocated to the present study.

In a mammal such as the badger, where complex behavioural mechanisms exist, it is likely that several factors can result in a sett not being used. Hence the fact that, for any one factor, a significant difference is found between the used and unused setts does not imply that this is the only factor operating, or even that it has any casual significance; however the fact that no significant difference is found does imply that a factor is not operating in the study area. For the purpose of this part of the present study two main classes of factor are considered likely to influence the choice of the sett site of the badger: the physical nature of the habitat, and the nature of the interactions within the badger population. Whilst it is accepted that the availability of food is also likely to be an important factor, This was not studied as it would have been difficult to relate availability of food to numbers without a detailed knowledge in advance of the study of what were the important foods in the diet in the study area and how far badgers will readily travel for food.

The 20 setts which have been used at least once (see p.20) are known to be suitable sett sites, unless there is any factor which causes the suitability to change from year to year. Of the other 69 setts some may be suitable for occupation, but it is assumed that at least some were not, hence these 69 setts would give an indication of the factors which might make the habitat unsuitable. It would thus be possible, to determine the factors which differ between the two groups; on the above assumption the differences would be related to the suitability of the sett site.

4.ii

PHYSICAL FACTORS.

a. Introduction.

Previous studies on the physical factors influencing the dispersion of badger setts have shown this to be influenced by the nature of the substrate. Dunwell & Killingley (1969) found that in an area where the substrate consisted of chalk capped with "clay with flints" the setts were concentrated on the chalk areas which were well drained and that the clay areas were avoided, presumably because of the tenacity of the material. Likhachev (1956) found, in a forest reserve in Russia where the substrate consisted of impermeable loam and sand, that there was a preference for the areas of well drained sand; however he did not state which species of badger was studied. Allen & Cowlin (1971) in a study in S.E. Essex, where the substrate consisted respectively of sand, boulder clay and river terrace gravel, found that most of the setts were on the sand, a few were on the river terrace gravel, and none were on the boulder clay. Various other factors been claimed to be of importance in modifying the dispersion pattern of badgers, but no detailed evidence has been given. Neal (1972) and Paget & Middleton (1974) stated that setts tend to be within approximately 30 m. of the edge of woodland. Neal (1948) reported that breeding setts tend to be near water.

Map 4.1 shows the visited, occupied and breeding setts for all the three surveys, against a background of the drift geology; it can be seen that most of the setts lie on the fluvio-

glacial sand. The positioning of the setts in the above manner could imply that fluvio-glacial sand is a preferred substrate, though this apparent preference might result from a factor, such as drainage, or the nature of the land use both according to the substrate. It was decided, in the light of the above evidence and the evidence from the authors quoted previously, to study the nature of the substrate, in terms of the percentage of clay & silt, the quantity of soil water, and the ease with which it could be dug. Distance to water and distance to the edge of woodland were also measured.

The factors mentioned above are unlikely to be an exhaustive list of those factors affecting the siting of badger sites, since some of the relationships mentioned above may be indirect, for example setts may be found on sandy slopes because these are often wooded. The type of slope was expected to be important, possibly through a micro-climate effect, possibly through a correlation with the substrate type, possibly because steep slopes enabled badgers to get further underground with less effort than with gentler slopes. The slope was described by its inclination, its shape in terms of convexity or concavity in the horizontal and vertical planes, its orientation in terms of aspect, and the setts position in terms of distance to the upper and lower breaks of slope. The following factors were also considered relevant: disturbance in terms of distance to the nearest habitation and in terms of distance to the nearest path, the amount of vegetation cover around the sett, and the habitat type. This was classed into four macro-habitats as follows: agricultural land, the strip

the strip within 20 m of the River Wear, the river bluff, and Maiden Castle. The latter was considered as being a separate habitat type because it combined the characteristics of both the river bank and river bluff habitats.

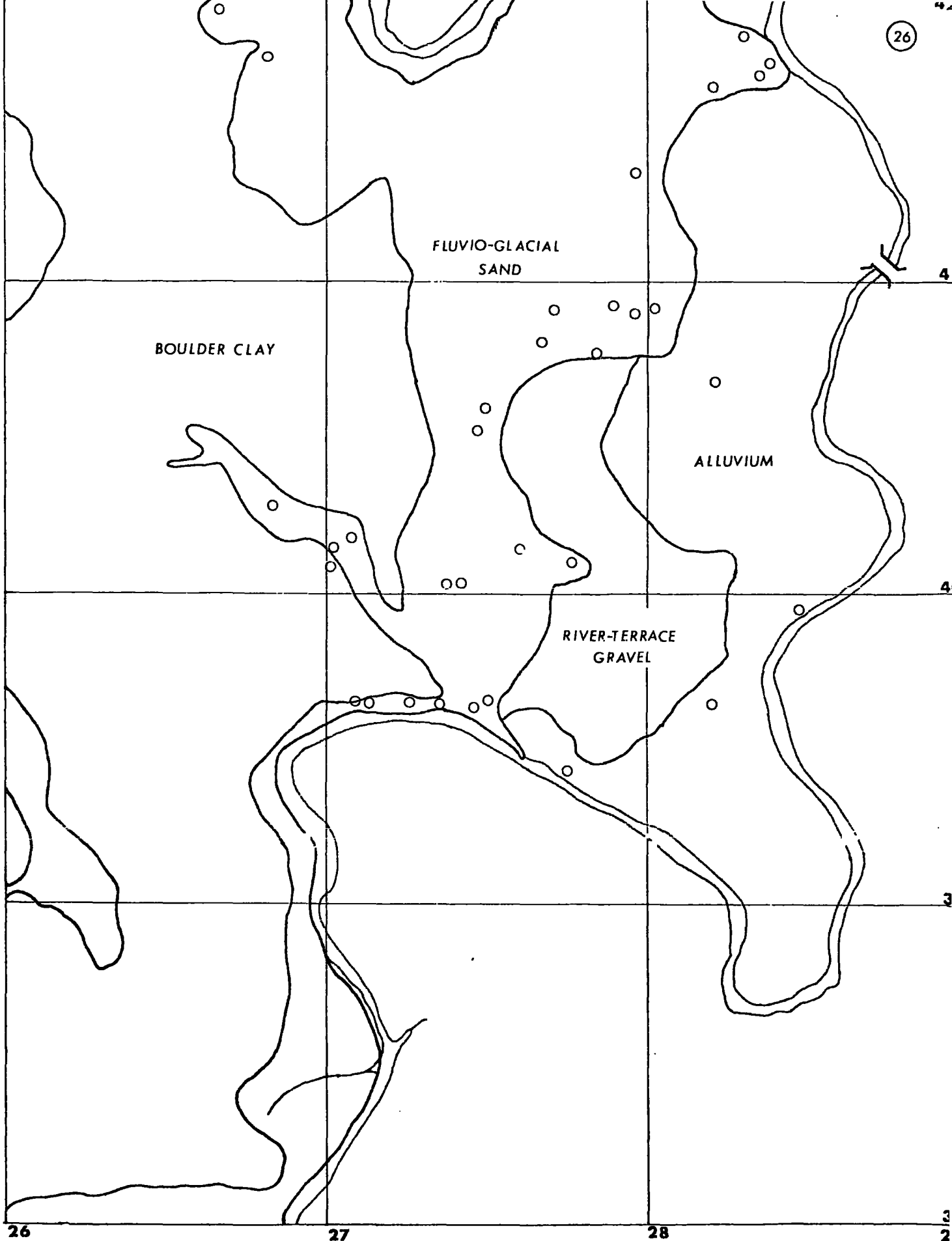

Grid Square NZ

MAP 4.1

Scale 1:15,900

The Relation of Sett Position to Drift Geology

○ = Sett
 = River

4. ii.

b. Methods.

Those variables which involved the measurement of distance, i.e. distance to habitation, water, nearest path, edge of woodland, and upper and lower breaks of slope, were measured along the ground if they were less than 100 m, or from a 1:8,600 map if they were greater. The position of the centre of the sett was judged by eye in the former case, and did not affect the measurement in the latter case, since the percentage of error was unimportant at distances greater than 100 m. The distance to habitation was considered as being that distance to the nearest group of three or more buildings, so as to exclude farm outbuildings from consideration. An area of trees was considered to be woodland if it exceeded one hectare in area. The positions of breaks of slope were judged by eye. Vertical convexity, horizontal convexity and cover were estimated on a subjective five point scale, over a distance of about 20 m. to either side of the centre of the sett, as judged by eye. The angle of the slope was calculated from the horizontal distance required to give a vertical drop of two metres.

The quantity of soil water was measured as the decrease in weight of a soil sample, when dried for 24 hours at 100° C, expressed as a percentage of the initial weight. The soil samples were taken from above the entrance holes. It was decided to sample from above the entrance because, although samples from both above and below the entrance would be affected by the change in soil drainage caused by the sett

it was thought the samples from above the entrance would not have been affected by the activities of the badgers in the sett. A minimum of two samples, or one per entrance hole, were taken at each sett. Ease of digging was measured in terms of the depth of penetration of a 1" by 1" blunt softwood stake, resulting from 25 blows of a hammer weighing approximately 500 g. Due to shortage of time this measure was not tested for consistency. The proportion of clay and silt was determined by shaking a soil sample in water, with detergent added to break down the crumb structure, allowing the sample to settle for 24 hours, and measuring the depth of the clay plus silt layer which resulted. This was expressed as a percentage of the depth of all the sediment layers combined. A small proportion of clay remained in colloidal form, but since the supernatant was fairly clear, the resulting error was considered to be acceptable. The soil sample was taken from the mound outside the entrance hole, because this material was likely to be representative of the substrate through which the sett was excavated. Two samples were taken per entrance hole.

4. ii.

c. The Nature of the Sample.

The data used for the study of habitat preference was collected during the period 2:5:1975 to 28:8:1975. Given the limited time available only a sample of the total number of setts was surveyed. This sample omitted the area in the fork of the A167 and A1050 (see map 2.1), because the problems in searching this area (see Census, Methods p. 8) might have caused a bias in the spatial analysis of the sett dispersion pattern: (see Social Factors, Methods p. 51), and it was thought better to use the same area for both parts of the analysis of dispersion. The following sett groups were not representate in the sample: the Blaid's Wood group, the Wagonway group, and the Low Burnhall group. There is no evidence of the sample chosen being non-random with respect to habitat type ($\text{Chi}^2 = 12.1$, $\text{d.f.}^1 = 9$, $p = 0.21$). Given that social factors may be a determinant of the occupation of setts, the sample of unoccupied setts which was chosen excluded any setts that had been visited, occupied or breeding during the previous surveys; this method of selection was intended to minimise any complication in the interpretation of results due to changes in sett occupancy.

1. "d.f." refers to degrees of freedom in a statistical test.

4.ii.

d. Statistical Methods.

Any statistical test requires certain assumptions concerning the nature of the statistical distributions of the data. Parametric distributions are derived from interval variables, which are on a scale in which the distances between numbers are of a defined size. Non-parametric distributions are derived from nominal and ordinal variables. The latter describe a ranked scale, but the distances between numbers are not defined. The former describe classes of objects or characteristics. The variables used in the present study are classified below according to the above criteria.

<u>NOMINAL</u>	<u>ORDINAL</u>	<u>INTERVAL</u>
-Habitat	-Sett Status	-Soil Water
-Horizontal Convexity	-Distance to Path	-Ease of Digging
-Vertical Convexity	-Distance to Habit- ation	
-Cover	-Distance to Water	
	-Distance to Edge of Woodland	
	-Distance to Upper and Lower Breaks of Slope	
	-Angle of Slope	
	-Percentage of Clay Plus Silt	

In order to determine the relation of each variable with sett status, and the interrelations between variables, the matrix shown over was used to determine the appropriate test for each pair of variables. The use and Description of these non-parametric tests is taken from Siegel (1956). The variables were examined initially for any patterning by using a χ^2 contingency table, comparing the variables grouped into classes as necessary. The most appropriate statistic was used after this initial examination.

	<u>INTERVAL</u>	<u>ORDINAL</u>	<u>NOMINAL</u>
<u>INTERVAL</u>	Pearson's r. Parametric One-Way Analysis of Variance.	Spearman's r. Parametric One-Way Analysis of Variance.	Parametric One-Way Analysis of Variance.
<u>ORDINAL</u>		Spearman's r. Kendal's tau.	Kruskal-Wallis One-Way Analysis of Variance.
<u>NOMINAL</u>			χ^2 . Contingency Coefficient.

4. ii.

e. Results.

1. Relationships with sett status.

The matrix shown in fig. 4.1 indicates which variables are significantly related to the status of the sett, and to one another; the direction of the relationship is indicated where relevant. The exact nature of the interactions is described below. Table 4.1 gives the contingency tables for the variables, grouped into interval ranges where necessary, so as to illustrate the nature of the relationship with sett status. The relationships described below refer to the changes of the variables within the classes of activity, not to the changes that are possible within the habitat. One variable, the aspect of the sett, is not shown in fig. 4.1, since many combinations of this variable were considered, and none of those tested showed any significant difference. It would not have been practicable to display all of these combinations on the matrix. Those tried were of classes 10° , 30° , 60° , and 90° with the compass folded over, with respect to each of the cardinal points, for each of these. The relationship is shown diagrammatically in fig. 4.2 for the the setts are arranged into 30° blocks; although there is an apparent tendency for the setts to face south-east, in fact there is no significant difference, in aspect, between the occupied and unoccupied setts ($\chi^2 = 3.39$, d.f. = 5 p- 0.5).

The soil type preferred for occupation is a dry, firm and relatively sandy soil, with about seven per cent. of clay plus silt. The values of the percentage of clay plus silt

are shown against a background of drift geology on map 4.2. The slope preferred is for occupations and breeding is convex in the horizontal plane whereas the unoccupied and breeding setts tend to be near the upper break of a slope, as compared to the unoccupied setts. The occupied and breeding setts tend to be further away from paths, though this is not uniformly shown e.g. sett H6. There is a tendency for occupied and breeding setts, mostly those within woodland to be close to the edge of woodland, whereas more of the unoccupied setts are at a greater distance from the edge of woodland (see table 4.1, 3). There is no tendency demonstrated for the unoccupied, visited or occupied setts to be near to water, but both the breeding setts in 1975 are within 60 m. of water¹. In fact no breeding sett has been found in any of the three surveys that was further than 60 m. from water. The relationships described above are summarised in fig. 4.3, as are the interrelations described in the next section.

2. Relationships between variables.

The matrix, fig. 4.1, also shows the interactions between variables. Many of the interactions with habitat type can be explained by the nature of the habitat, e.g. the river bank setts are significantly closer to water than other sett groups. Since many of the river bank and agricultural land setts tend to be further away from Durham City than the river bluff and Maiden Castle groups, there is a significant relationship between habitat, and distance 1. If the breeding setts are tested against the rest, and distance to water is divided into $<60\text{m}$ and $\geq 60\text{m}$ then $\chi^2=5.4$, d.f.=1, $p=0.02$.

to path and habitation. The distance to the edge of woodland is related to habitat type because the river bluff setts, which are in a large tract of woodland, can be further away from the edge of woodland than other groups. There is a relationship between the distance to the lower break of slope and habitat type because slopes in the river bank and agricultural landgroups tend to be shorter than in the river bluff and Maiden Castle groups. The interaction between ease of digging and habitat type is more difficult to explain; the most likely explanation is that there are more soft sandy soils in the river bluff area than elsewhere.

The interrelations between variables can be ascribed either to the nature of the habitat or to the nature of the variables. The former class consists of those interactions in which both variables interact with habitat type. These are shown in fig. 4.1 and will be considered in the discussion. There are only five interactions that fall into the latter class: vertical convexity / distance to water, distance to water, distance to edge of woodland / soil water, distance to upper break of slope / distance to lower break of slope, horizontal convexity / percentage clay plus silt, and cover / ease of digging. These can be explained in terms of the geography of the study area and will be discussed, where relevant to the status of the sett, in the next section.

THE ASSOCIATIONS WITH THE STATUS OF THE SETT, INCREASING FROM UNOCCUPIED TO BREEDING, FOR ALL THE VARIABLES EXCEPT ASPECT. THE INTER-RELATIONS BETWEEN VARIABLES ARE ALSO SHOWN.

	STATUS	D. WATER		D. PATH		D. HABITATION		D. WOODLAND		D. UPPER		D. LOWER		H. CONVEXITY		V. CONVEXITY		COVER		INCLINATION		SOIL WATER		EASE DIG.		% CLAY		HABITAT	
D. WATER	1																												
D. PATH	χ^2	-																											
D. HABITATION	-	T^+	T^+	T^+	T^+	T^+	T^+	T^+	T^+	T^+	T^+	T^+	T^+	T^+	T^+	T^+	T^+	T^+	T^+	T^+	T^+	T^+	T^+	T^+	T^+	T^+	T^+	T^+	T^+
D. WOODLAND	T^+	-																											
D. UPPER	T^+	-																											
D. LOWER	-	-																											
H. CONVEXITY	χ^2	-																											
V. CONVEXITY	-	KW	-																										
COVER	-	-																											
INCLINATION	-	-																											
SOIL WATER	ANO	-																											
EASE DIG.	T^+	T^+	T^+	T^+	T^+	T^+	T^+	T^+	T^+	T^+	T^+	T^+	T^+	T^+	T^+	T^+	T^+	T^+	T^+	T^+	T^+	T^+	T^+	T^+	T^+	T^+	T^+	T^+	T^+
% CLAY	T^+	-																											
HABITAT	-	χ^2	χ^2	χ^2	χ^2	χ^2	χ^2	χ^2	χ^2	χ^2	χ^2	χ^2	χ^2	χ^2	χ^2	χ^2	χ^2	χ^2	χ^2	χ^2	χ^2	χ^2	χ^2	χ^2	χ^2	χ^2	χ^2	χ^2	χ^2

- Indicates that no relationship exists.

Abbreviations.

D. = Distance to

H. = Horizontal

V. = Vertical

INCLINATION = Angle of Slope

UPPER = Upper Break of Slope

LOWER = Lower Break of Slope

EASE DIG. = Ease of Digging

% CLAY = Per cent. Clay & Silt

Statistical Tests (inclusion implies $p \leq 0.05$)

χ^2 = The Chi² Test.

T^+ / T^- = Kendal's Rank Correlation Coefficient, positive and negative respectively.

r_s = Spearman's Rank Correlation Coefficient, sign as above.

KW = Kruskal-Wallis One Way Analysis of Variance

ANO = Parametric Analysis of Variance.

1 = Distance to water is only important in relation to breeding (see p. 34).

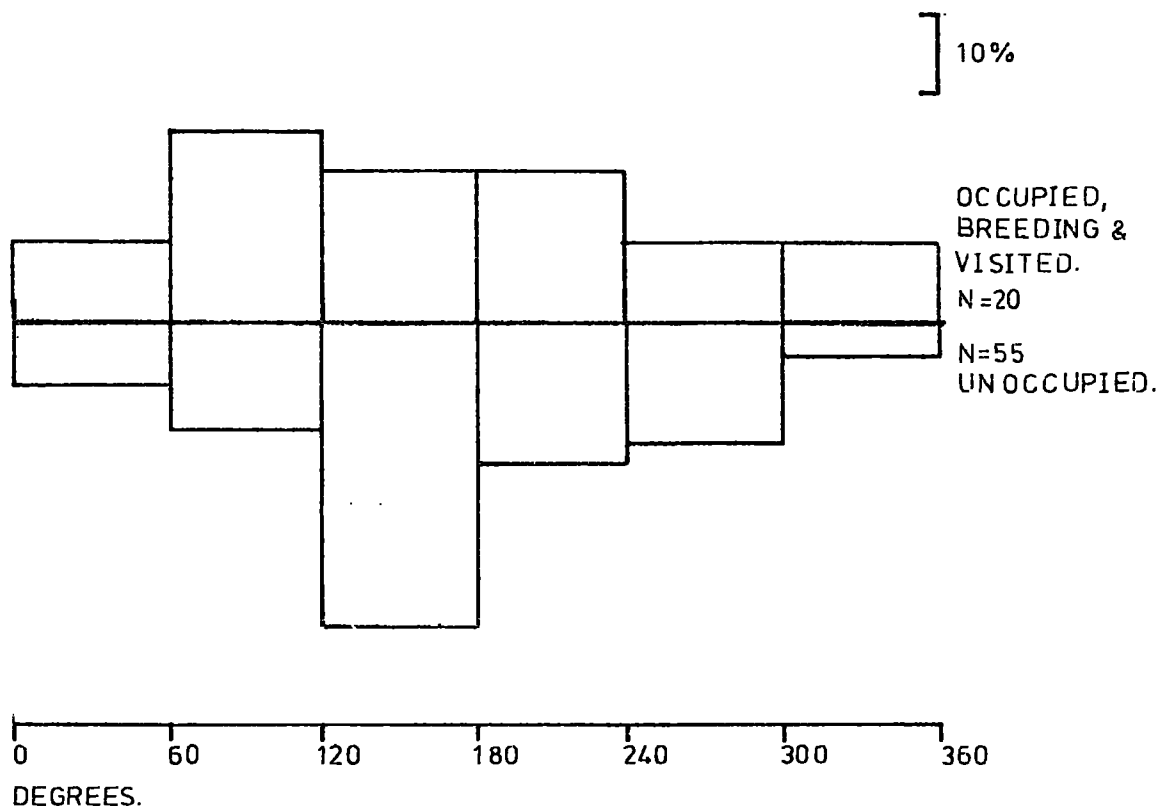

[0°=MAGNETIC NORTH]

FIG 4,2

The relationship of sett occupation with aspect (1975 data).

THE VARIABLES WHICH AFFECT THE DEGREE OF ACTIVITY OF THE SETT,
TOGETHER WITH WITH THE INTERRELATIONS BETWEEN THOSE VARIABLES.

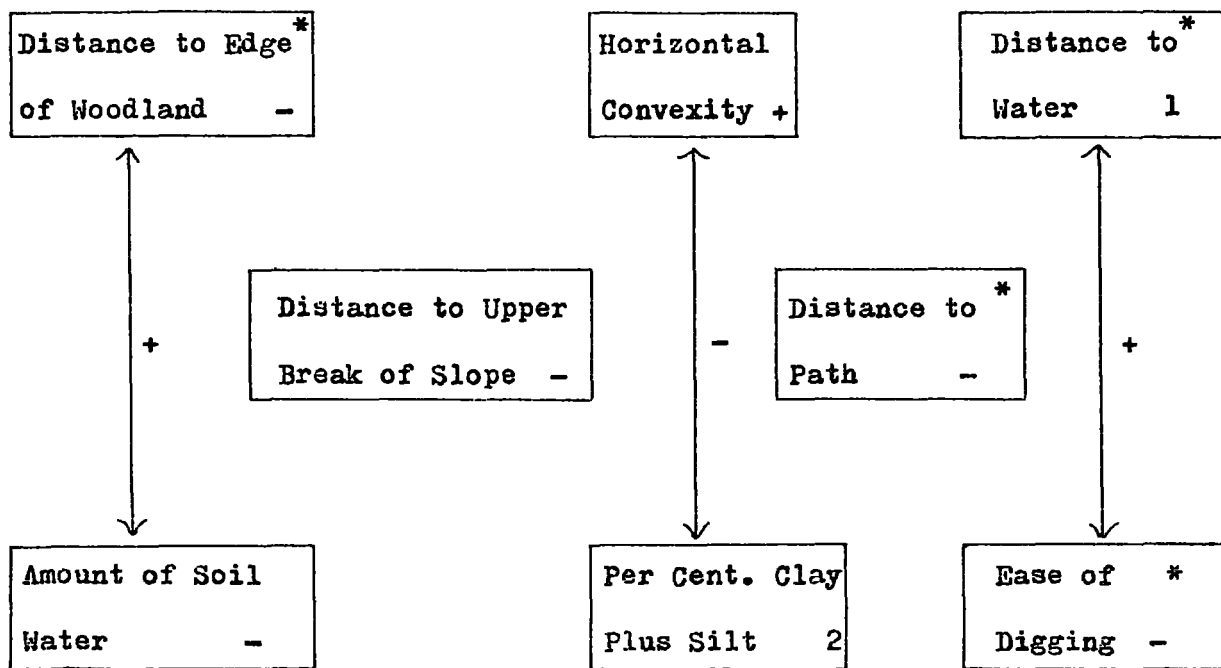

* Indicates a significant association with habitat type.

1 Relevant only for breeding setts (see p. 34).

2 An intermediate amount of clay plus silt is preferred for occupation (p. 46).

+ Indicates a positive relationship.

- Indicates a negative relationship.

↗ Significant interrelation between variables.

N.B. The inclusion of any relationship implies that $p < 0.05$.

THE VARIABLES WHICH AFFECT THE DEGREE OF ACTIVITY OF THE SETT,
TOGETHER WITH WITH THE INTERRELATIONS BETWEEN THOSE VARIABLES.

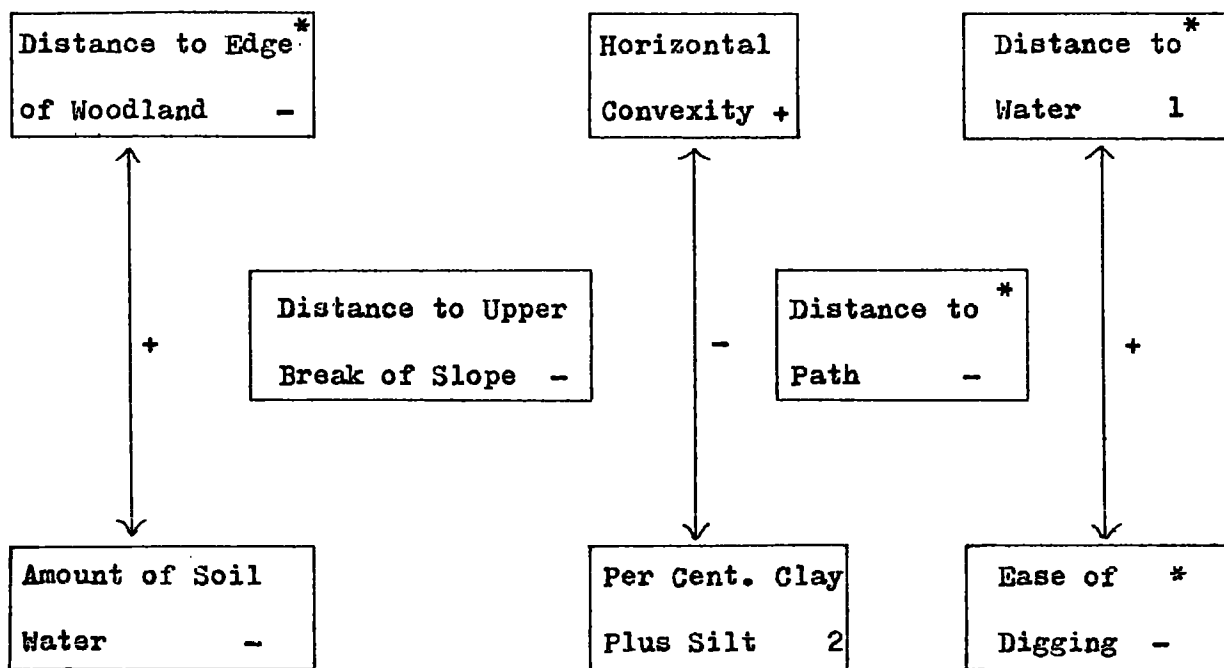

* Indicates a significant association with habitat type.

1 Relevant only for breeding setts (see p. 34).

2 An intermedialte amount of clay plus silt is preferred for occupation (p. 46)

+ Indicates a positive relationship.

- Indicates a negative relationship.

↗ Significant interrelation between variables.

N.B. The inclusion of any relationship implies that $p < 0.05$.

TABLE 4.1.

The table shows the contingency tables of the variables used in the analysis of physical factors. The variables are divided into frequency classes where appropriate. In the tables the status of the sett is abbreviated as follows:

UNOCC = Unoccupied.

VISIT = Visited.

OCC = Occupied.

BREED = Breeding.

The χ^2 statistic is used to compare the difference between the unoccupied visited, occupied and breeding setts. However this statistic is not necessarily the statistic used to test significance in fig. 4.1 (p. 36).

1. DISTANCE TO WATER (METRES).

	0 - 40	41 - 80	81 - 120	121 - 160	161 - 300	ROW TOTAL
<u>STATUS</u>						
UNOCC	3	4	1	0	11	19
VISIT	1	1	0	1	1	4
OCC	1	1	2	1	2	7
BREED	1	1	0	0	0	2
COLUMN TOTAL	6	7	3	2	14	N = 32

$$\chi^2 = 12.6 \quad \text{d.f.} = 12 \quad p = 0.40$$

2. DISTANCE TO THE NEAREST PATH (METRES).

	0 - 40	41 - 80	81 - 120	121 - 160	161 - 300	ROW TOTAL
<u>STATUS</u>						
UNOCC	16	2	0	1	0	19
VISIT	3	0	0	0	1	4
OCC	4	0	0	2	1	7
BREED	1	0	0	1	0	2
COLUMN TOTAL	24	2	0	4	2	N = 32

$$\chi^2 = 11.3 \quad \text{d.f.} = 9 \quad p = 0.25$$

3. DISTANCE TO NEAREST HABITATION (METRES).

	0 - 200	201 - 400	401 - 600	601 - 999	ROW TOTAL
<u>STATUS</u>					
UNOCC	11	6	0	2	19
VISIT	3	0	1	0	4
OCC	3	2	2	0	7
BREED	1	0	0	1	0
COLUMN TOTAL	18	8	3	3	N = 32

$$\text{Chi}^2 = 12.7 \quad \text{d.f.} = 9 \quad \text{p} = 0.18$$

4. DISTANCE TO EDGE OF WOODLAND (METRES).

	0 - 40	41 - 80	81 - 120	121 - 160	161 - 300	ROW TOTAL
<u>STATUS</u>						
UNOCC	6	5	4	2	2	19
VISIT	1	1	1	0	1	4
OCC	6	1	0	0	0	7
BREED	1	1	0	0	0	2
COLUMN TOTAL	14	8	5	2	3	N = 32

$$\text{Chi}^2 = 9.9 \quad \text{d.f.} = 12 \quad \text{p} = 0.62$$

5. DISTANCE TO UPPER BREAK OF SLOPE (METRES).

	0 - 20	21 - 40	41 - 60	61 - 100	ROW TOTAL
<u>STATUS</u>					
UNOCC	11	6	1	1	19
VISIT	4	0	0	0	4
OCC	7	0	0	0	7
BREED	2	0	0	0	2
COLUMN TOTAL	24	6	1	1	N = 32

$$\text{Chi}^2 = 7.3 \quad \text{d.f.} = 9 \quad \text{p} = 0.61$$

6. DISTANCE TO THE LOWER BREAK OF SLOPE (METRES).

	0 - 25	26 - 50	51 - 75	76 - 100	101 - 125	ROW TOTAL
<u>STATUS</u>						
UNOCC	6	6	2	3	2	19
VISIT	2	1	0	0	1	4
OCC	3	3	1	0	0	7
BREED	1	0	0	1	0	2
COLUMN TOTAL	12	10	3	4	3	N = 32

$$\text{Chi}^2 = 7.9 \text{ d.f.} = 12 \text{ p} = 0.79$$

7. HORIZONTAL CONVEXITY.

	+CONCAVE	CONCAVE	FLAT	CONVEX	+CONVEX	ROW TOTAL
<u>STATUS</u>						
UNOCC	2	8	4	5	0	19
VISIT	0	0	1	1	2	4
OCC	0	0	2	4	1	7
BREED	0	0	0	0	2	2
COLUMN TOTAL	2	8	7	10	5	N = 32

$$\text{Chi}^2 = 24.9 \text{ d.f.} = 12 \text{ p} = 0.02$$

8. VERTICAL CONVEXITY.

	CONCAVE	FLAT	CONVEX	+CONVEX	ROW TOTAL
<u>STATUS</u>					
UNOCC	3	5	9	2	19
VISIT	0	2	2	0	4
OCC	0	4	3	0	7
BREED	1	0	1	0	2
COLUMN TOTAL	4	11	15	2	N = 32

$$\text{Chi}^2 = 7.6 \text{ d.f.} = 9 \text{ p} = 0.58$$

9. THE AMOUNT OF VEGETATION COVER AROUND THE SETT

<u>STATUS</u>	OPEN				SHADED	ROW TOTAL
	1	2	3	4	4	
UNOCC	1	7	4	7		19
VISIT	1	0	2	1		4
OCC	2	1	3	1		7
BREED	1	0	0	1		2
COLUMN TOTAL	5	8	9	10		N = 32

$$\text{Chi}^2 = 9.9 \quad \text{d.f.} = 9 \quad \text{p} = 0.36$$

10. THE ANGLE OF INCLINATION OF THE SLOPE (DEGREES).

<u>STATUS</u>	19*	23 - 26	27 - 30	31 - 36	ROW TOTAL
	- 22				
UNOCC	4	7	6	2	19
VISIT	0	2	0	2	4
OCC	2	1	2	2	7
BREED	1	1	0	0	2
COLUMN TOTAL	5	8	9	10	N = 32

$$\text{Chi}^2 = 8.4 \quad \text{d.f.} = 9 \quad \text{p} = 0.49$$

11. THE PERCENTAGE OF WATER IN THE SOIL, IN TERMS OF WET WEIGHT.

<u>STATUS</u>	3 - 6	7 - 10	11 - 14	15 - 18	19 - 22	ROW TOTAL
	UNOCC	1	5	2	3	
VISIT	2	1	1	0	0	4
OCC	2	2	0	0	0	4
BREED	1	1	0	0	0	2
COLUMN TOTAL	6	9	3	3	3	N = 24

$$\text{Chi}^2 = 10.3 \quad \text{d.f.} = 12 \quad \text{p} = 0.59$$

* No setts were found on slopes of less than 19° inclination.

12. THE EASE OF DIGGING OF THE SOIL (SEE NOTE BELOW).

	3 - 6	7 - 10	11 - 14	15 - 18	19 - 22	ROW TOTAL
<u>STATUS</u>						
UNOCC	1	8	4	1	2	16
VISIT	1	2	1	0	0	4
OCC	2	3	2	0	0	7
BREED	1	1	0	0	0	2
COLUMN TOTAL	5	14	7	1	2	N = 29

$$\text{Chi}^2 = 6.1 \text{ d.f.} = 12 \text{ p} = 0.91$$

13. THE PERCENTAGE OF CLAY PLUS SILT IN THE SOIL.

	3 - 5	6 - 8	9 - 11	12 - 15	ROW TOTAL
<u>STATUS</u>					
UNOCC	2	2	6	4	14
VISIT	0	2	2	0	4
OCC	0	3	0	0	3
BREED	0	2	0	0	2
COLUMN TOTAL	2	9	8	4	N = 23

$$\text{Chi}^2 = 13.2 \text{ d.f.} = 9 \text{ p} = 0.15$$

N.B. The ease of digging was measured in terms of the depth of penetration (cms.) of a 1" by 1" blunt softwood stake, for 25 blows of a 500 g. hammer.

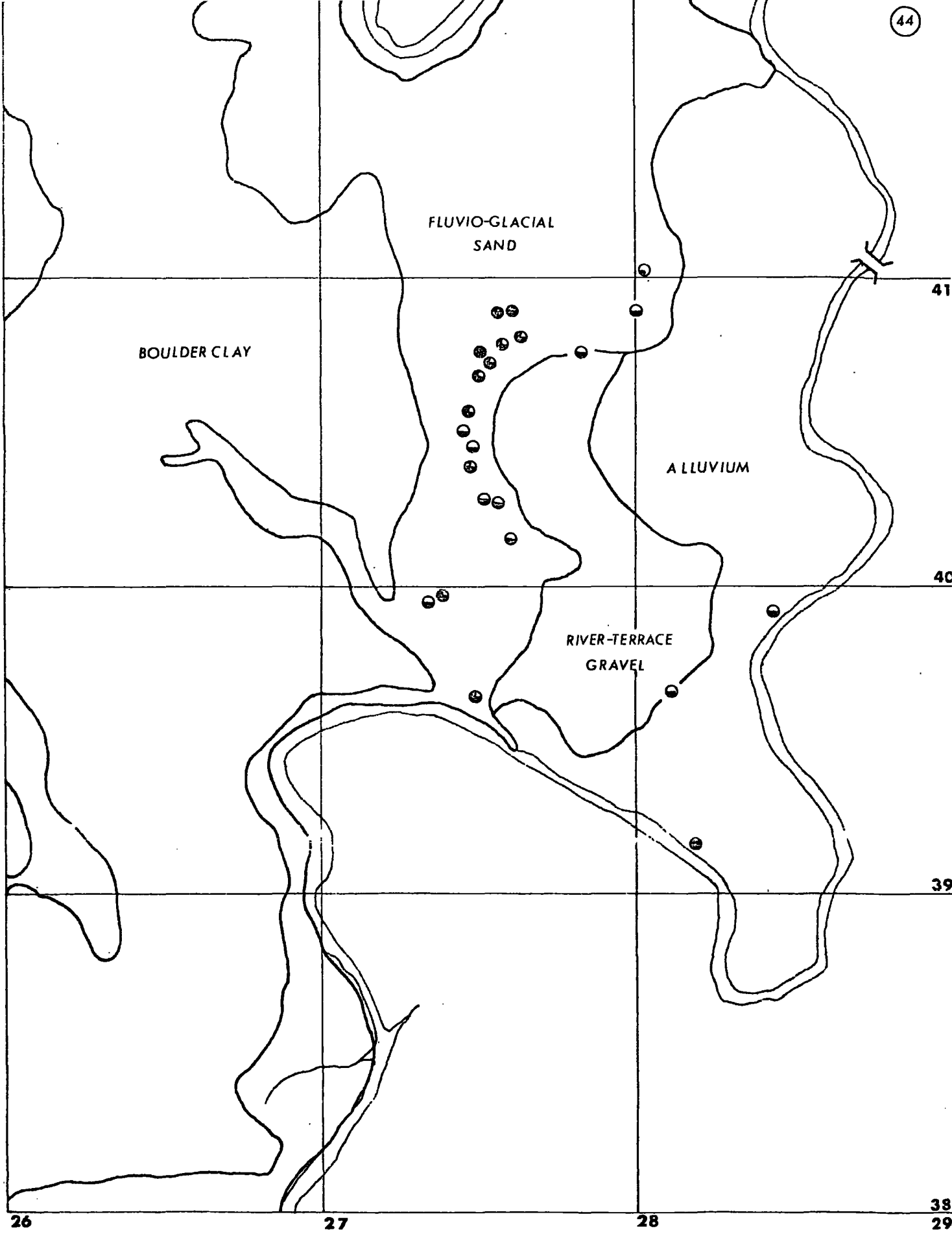

Grid Square NZ
Scale 1:15,900

MAP 4.2

Drift Geology of the Study Area and Percentages of Clay
Plus Silt in Soil at Sett Sites.

- = Sett
 - ▬▬ = River
 - (horizontal lines) = 3-5
 - (vertical lines) = 6-8
 - (diagonal lines) = 9-11
 - (cross-hatch) = 12-15
- } Clay/Silt

4.ii.

f. Discussion.

Table 4.1 indicates the nature of the differences, in the factors measured, as compared to the four activity classes; these differences are summarised in fig. 4.3. The preferences referred to only indicate whether or not a sett is likely to be occupied, within the present study area. Those variables which are correlated may either be acting as correlates of the same ultimate factor, or acting individually, the correlation between them being unrelated to their relationship to sett status. The interrelated factors are thus considered in pairs.

The preference for well drained soils has been noted in the introduction (p. 23), as has the fact that setts tend to be close to the edge of woodland (also p. 23). The preference for drier soils may result from either the need for a dry sett, i.e. comfort, or from there being less chance of the sett flooding. It is unlikely that the tendency for the setts to be near the edge of woodland ^{e/} is related to the choice of drier soils, since although there may be mechanisms of interaction, the preference for occupying the setts on drier soils is also shown amongst those setts situated in open ground. The fact that occupied setts tend to be close to the edge of

woodland may result from either the need for mixed feeding or from the nature of the land use in the study area, i.e. the tops of slopes tend to form woodland boundaries. This will be discussed later (see section 6, p. 99) in the light of evidence from the analysis of diet.

The preference for an intermediate amount of clay plus silt may result from either the mechanical properties of the soil, or from an interaction with soil drainage; this interaction was not observed in the present admittedly biased sample. Tunnels dug in a very sandy substrate will tend to cave in, whereas tunnels dug in a substrate with a high clay content will be difficult to dig, and may be liable to flooding in certain positions. The fact that the setts are dug in a substrate with some clay present, indicates a compromise between these two tendencies. The interaction with horizontal convexity may result from either a correlation of the slope type with the nature of the substrate, or from the convex slopes being inherently suitable. Convex slopes may be preferred because it is less likely that surface water will drain into a sett on a horizontally convex slope, than on a horizontally concave slope.

Distance to water is only found to be significant when the breeding setts (including the Durham School sett) are

compared with the unoccupied, visited and occupied setts; this tendency could result from an increased need for water by the sow during lactation, and because when the cubs first come above ground they are unable to travel as far from the sett as the adults. Since distance to water is only an important parameter for breeding setts it is likely that the relationship with ease of digging is due to the biased nature of the sample. The preference for harder soils is better described as a preference for firmer soils. This preference is probably due to the mechanical properties of the soil, i.e. the substrate will hold up well (see previous page).

The tendency for active setts to be near paths results from the fact that paths run along breaks of slope, and there is a tendency for active setts to be near the upper breaks of slope. the latter tendency could be due to the need to keep above the water table, particularly in the river bank setts, and this need may be important in the river bluff setts, depending on the capilarity of the fluvio-glacial sand and the pattern of ground water flow.

In conclusion the changes within the classes of activity show that there is a preference for occupying a well drained sett that is in a substrate which produces tunnels which

"hold up" well, is close to the upper break of slope, and is probably close to the edge of woodland. In addition, if it is a breeding sett it is likely to be within reasonable reach of water, i.e. less than approximately 60 m from water. It should be noted that all the setts found in the study area were on slopes.

4. iii.

SOCIAL FACTORS.

a. Introduction.

Spatial structure in vertebrate and in invertebrate populations is a common phenomenon, and is often simply described as spacing or territoriality, and not examined per se. Two examples where the spatial distribution of bird populations have been examined in relation to behaviour are the studies of Patterson (1965) and Krebs (1971). Patterson (1965) found that in Black-headed Gulls, nests were aggregated into colonies and within a colony evenly distributed. Krebs (1971) showed that in Great Tits the nests were spaced at greater distances than expected by chance. The cause of the spatial structure was anti-predator behaviour and territorial behaviour respectively. There have been few studies of the spatial distributions of mammal burrows. Clarke (1956) examined the distribution of Cynomys burrows, using King's (1955) data, and found negative grouping i.e. the burrows were further apart than expected by chance, which Clark (1956) considered was related to the social behaviour of Cynomys. In this context the burrow can be considered as the focus of the home range of the animal, and as such social behaviour will be reflected in the distribution of the burrows.

The studies mentioned above related the spatial pattern to the observed behaviour, and except Krebs (1971), dealt with reasonably homogeneous habitats. Since the

badger setts do not occupy a homogeneous habitat and no information was available concerning the behavioural interactions, random distances have to be derived so as to take into account the nature of the study area, and the behaviour has to be inferred from the previous studies.

In the previous section (4. ii. f. p. 45-48) it was concluded that the occupation of the setts was affected by the physical parameters of the habitat. However since some occupied setts have become unoccupied, it must be assumed that physical factors alone do not necessarily determine whether or not a given sett is occupied. Setts could become unoccupied because of changes in the physical factors or because of changes within the badger population such as a drop in population, a change in the population structure, or an interaction between the characteristics of the population and social behaviour. It is less likely that spatial organisation would result through habitat changes, since these are likely to be random with respect to neighbouring setts, than through social behaviour. Hence the aim of this part of the study is to infer the badgers social behaviour from the spatial organisation of the setts.

4.iii.

b. Methods.

The method of spatial analysis used is that of near neighbour analysis, reviewed by Southwood (1966, p.39-43). Clark and Evans (1954), and Thompson (1956) give formulae for the near neighbour distances that would be expected from a uniform i.e. hexagonal, and from a random distribution, which results from some factor causing repulsion between points such as competition or territoriality, will give greater near neighbour distances than expected by chance. These distances are derived from a model which assumes a uniform habitat. Since the habitat in the present study is non-uniform, these formulae are not applicable, but they do however give the expected direction of an effect.

In the present study "random" near neighbour distances were produced by two methods, referred to in future as type one and type two random. The method used to produce the type one random distances involved "occupying" at random i.e. by the use of random numbers, those setts that had been occupied in the past or present surveys¹, so as to produce a sample of the same size as the number of occupied setts in the given year. The points for the type

¹

Since any missing sett would bias the results of the spatial analysis of a small sample (I. Evans, pers. comm.), the setts in the fork of the A167 & A1050 are not included in the analysis (see Census, Methods p.7). In future the text refers to the limited study area to the east of the two roads.

two random distances were produced by randomly generating setts in 50 by 50 m. blocks of the study area. These 50 by 50 m. blocks were delimited according to some of the parameters found, in the previous section, to affect sett status. The substrate type could not be measured so it was assumed that setts could exist on slopes or banks, on any substrate type except boulder clay and bedrock, in areas where these were either flat or convex in the horizontal plane, within 20 m. of the upper break of slope, and within 80 m. of the edge of woodland. The near neighbour distances in the random sample were calculated as for the observed data. The type one random distances represent an unduly restricted sample, and the type two random distances represent a sample in which the conditions are not sufficiently strictly defined. Thus the results from the two are expected to give an approximation to the actual patterning caused by the habitat.

The distances between the setts were measured if they were less than 100 m. and calculated from the formula below if they were greater than 100 m.

$$D_{ij} = \sqrt{(X_i - X_j)^2 + (Y_i - Y_j)^2}$$

Where D_{ij} is the distance between the i^{th} and j^{th} sett respectively. The distance calculated is the straight line distance in the horizontal plane. No allowance has been made for slope, or curvature. However most badger paths run along reasonably straight lines, and when the distance is greater than 100 m., the distance calculated is an approximation to the distance likely to be travelled by a badger. For a ten per cent. error in the actual straight line distance a curved bank of radius 65 m. or a slope of

angle 27° is required. Since these figures are towards the extremes in the study area, an error of around ten per cent. may be assumed.

The analysis considers the first near neighbour distances for the occupied and breeding setts, found in all the surveys. These are compared with a type one random distribution. No statistics are given, since the sample is small and the statistical distribution is difficult to describe. The first five near neighbours are examined for the visited, occupied and breeding setts found in all the surveys. All the surveys are compared with a type one random sample and the 1975 survey is also compared with the type two random distribution. The distributions of distances are compared using a χ^2 test, the distributions being divided into frequency classes of multiples of 100 m.

The details of interpretation of the n^{th} near neighbour distances, together with their random expectations are given in Thompson (1956). The use of the n^{th} near neighbour gives information about more than one level of structure. An example is shown below, in this case where there is a strong tendency for points to be grouped in pairs.

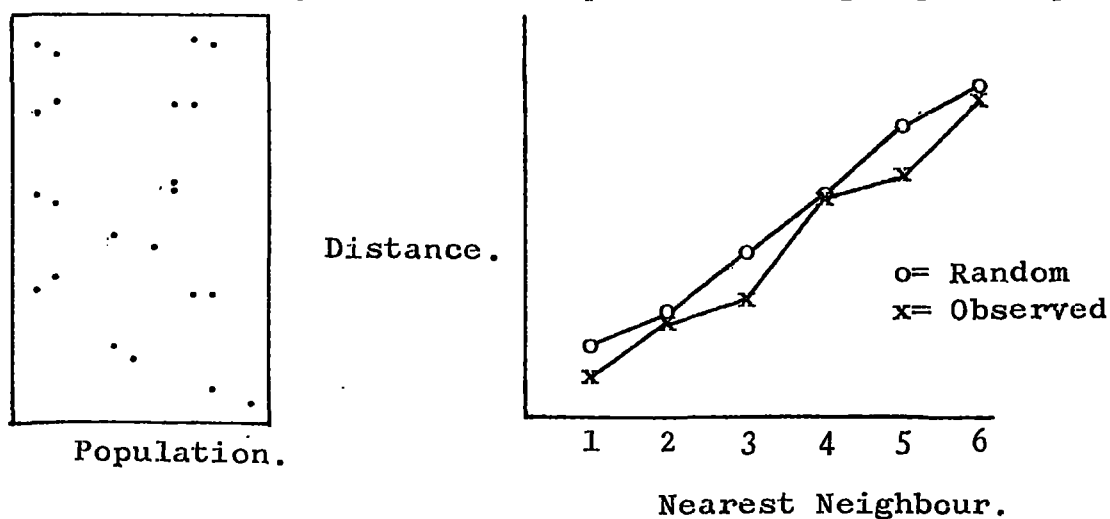

The phenomena shown in the example overleaf can be generalised to clusters of n points, where the first $n-1$ near neighbours will be closer than expected, the n^{th} near neighbour will be spaced at random, and the next $n-1$ will be closer than random et seq..

Since the interpretation of the n^{th} near neighbour distances involves the consideration of clusters, within the distribution of points; it is useful to have an alternative method of determining clustering, so as to aid interpretation of the near neighbour analysis. The following method was suggested by I. Evans (pers. comm.). It consists of finding the two points which are closest together, and determining their centroid. The procedure is repeated on a new set of points, consisting of the uncombined points, and the centroids of the points that have been combined. This procedure is repeated until all points and centroids of points have been combined. The results are presented as a dendrogram. An example of the use of the procedure is shown below, and the resulting dendrogram is shown over.

Procedure.

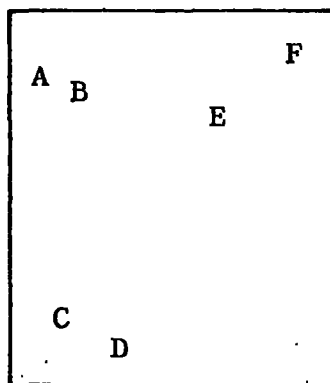

Population of Points,
Represented by Letters.

Stage.	Points Joined.
1	A + B
2	E + F
3	C + D
4	(A + B) + (E + F)
5	((A + B) + (E + F)) + (C + D)

It can be seen from this example the manner in which the method gives an indication of the grouping of points. Although this method is not amenable to statistical analysis, it gives a good estimation of the structure of

Dendrogram.

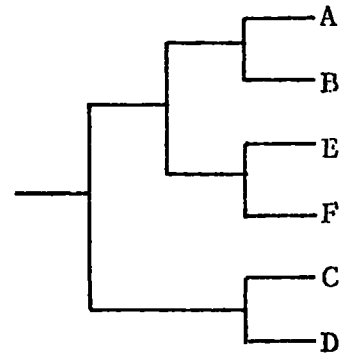

the distribution. It has the advantage of not making any assumptions as to the exact relationship between social interactions and distance, except that interactions are more likely to occur between setts that are closer together. The method also shows the arrangement of visited, occupied and breeding setts.

4. iii.

c. Results.

Fig 4.4 shows the histograms of the near neighbour distances for the occupied, and breeding setts, for all three surveys, compared with the type one random distances. In the results for 1975 there are more near neighbour distances in the range 400 - 499 m. than in the random sample; the distances in the range 0 - 99 m. come from the Maiden Castle setts. The histograms of distances for the 1971 setts are similar to the random sample. The near neighbour distances for the 1968 setts are greater than the random sample, there again being a peak in the range 400 - 499 m., which is more marked than in 1975.

Figs. 4.5, 4.6 and 4.7 show the dendrograms, displaying the arrangement of the visited, occupied and breeding setts for all the surveys. The dendrogram for the 1975 setts shows five pairs of setts, three groups of three setts and one single sett. The dendrogram for the 1971 setts shows four groups of four setts, one group of three setts, and one single sett. The dendrogram for the 1968 setts shows one group three setts, three groups of two setts and four single setts, which may form parts of higher groupings. With one exception, WW2 + GH15, the 1975 dendrogram shows pairs or triplets consisting of at least one occupied or breeding sett. A similar pattern is shown in the 1971 dendrogram. The pattern is similar in 1968, except for the single setts and a triplet of setts, GH13 + GH21 + GH12, which are all visited.

Fig 4.8 shows graphically the first five mean near neighbour distances, for the visited, occupied and breeding setts for each of the three surveys. The significant differences between the observed distances and the type one or type two random distances are also shown. Histograms of these distances are shown in figs. 4.9, 4.10, 4.11 and 4.12. These are for the 1975 near neighbour distances compared with the type one, and type two random samples, and for the 1971, and 1968 near neighbour distances compared with the type one random sample respectively.

The 1975 mean near neighbour distances show a distinct patterning (fig. 4.8, upper graph), compared with the type one random mean near neighbour distances; this difference is significant for the second ($p=0.031$) and the fourth ($p=0.024$) near neighbours, and is close to significance for the fifth near neighbour ($p=0.053$). The shape of the graph indicates that there is a tendency to form pairs of setts. The means of the 1975 near neighbour distances are all significantly different from the means of the type two random near neighbour distances. It should be noted that the shapes of the curves of the mean type one and type two near neighbour distances are similar, although the type one random means are greater. The 1971 mean near neighbour distances are less than the type random mean near neighbour distances (fig. 4.8, middle graph). However only the mean of the fifth near neighbour is significantly less.¹

¹ Although the means would appear similar in fig. 4.8, the distributions are different; see fig. 4.11, bottom histogram.

distribution. The distributions of the first three near neighbour distances in 1968 (fig. 4.12) are similar to those produced by the type one random sample. The fourth and fifth near neighbour distributions show peaks at 500 - 599 m which are not present in the type one near neighbour distributions, the fourth near neighbour distribution being significantly different from the type one random near neighbour distribution,

In general the results show that the patterning changes from year to year. The occupied and breeding setts in 1968 and 1975 are overdispersed. The setts tend to form groups, the mean group sizes being 2.2, 3.3 and 1.9 from the dendrograms, and the group sizes suggested by the near neighbour analysis are two, four and four, for the years 1975, 1971 and 1968 respectively. The fourth near neighbour distributions of the visited, occupied and breeding sett show peaks between 400 and 599 m., when compared with the corresponding type one random sample near neighbour distributions. The graphs of the 1968 and 1971 mean near neighbour distances (fig. 4.8) tend to be more peaked than the type one random mean distances. In comparison to the type two random sample the observed mean near neighbour distances and the type one random mean near neighbour distances are greater, suggesting that either badgers do not exploit all the possible sites for setts or that the criteria used to delimit the suitable area are not adequate.

1975

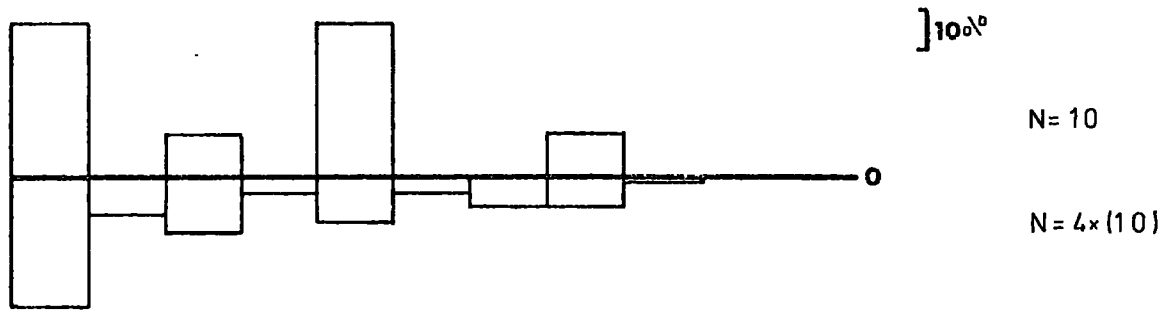

1971

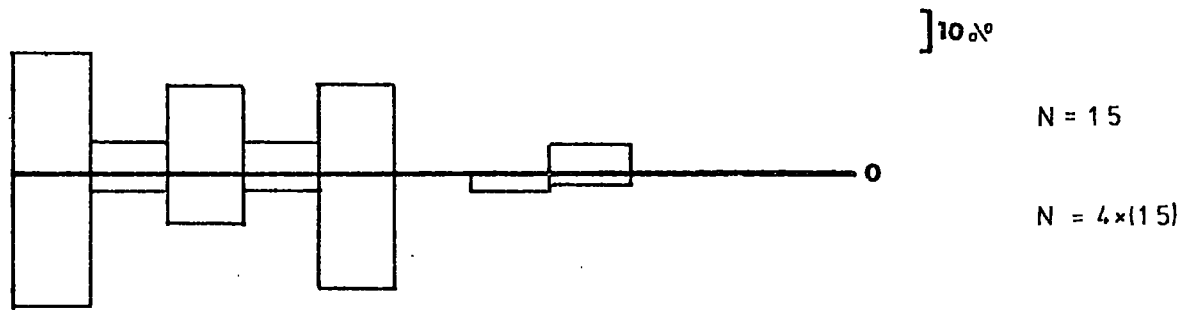

1968

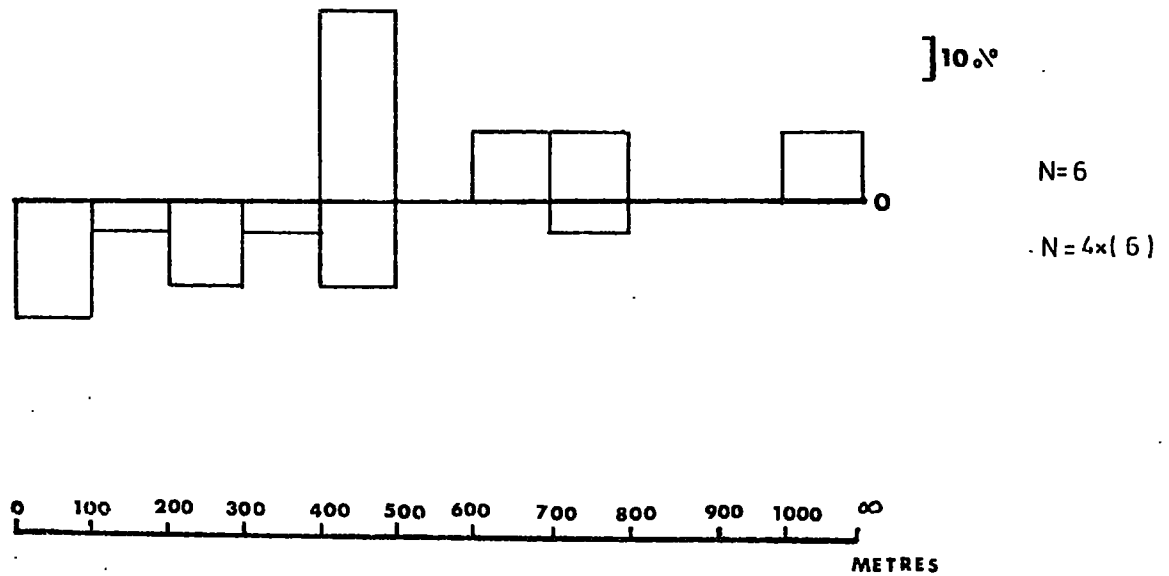

FIG 4.4

Histograms of the first nearest neighbour for the active & breeding setts for the years 1968, 1971 and 1975.

Upper = Observed Lower = Type 1 random.

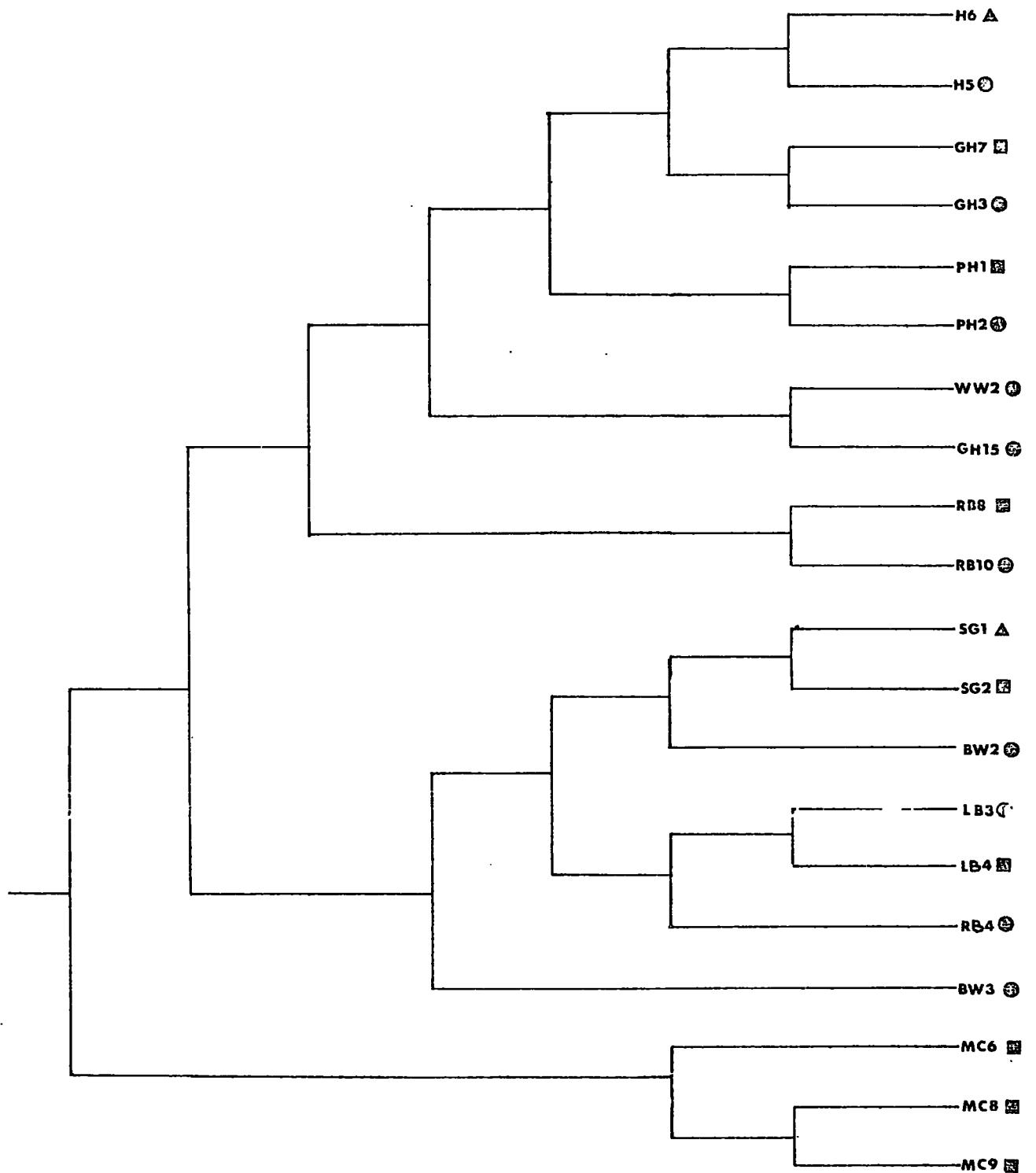

FIG 4,5

Dendrogram of the 1975 breeding (▲), occupied (■) and visited (⊙) sets.

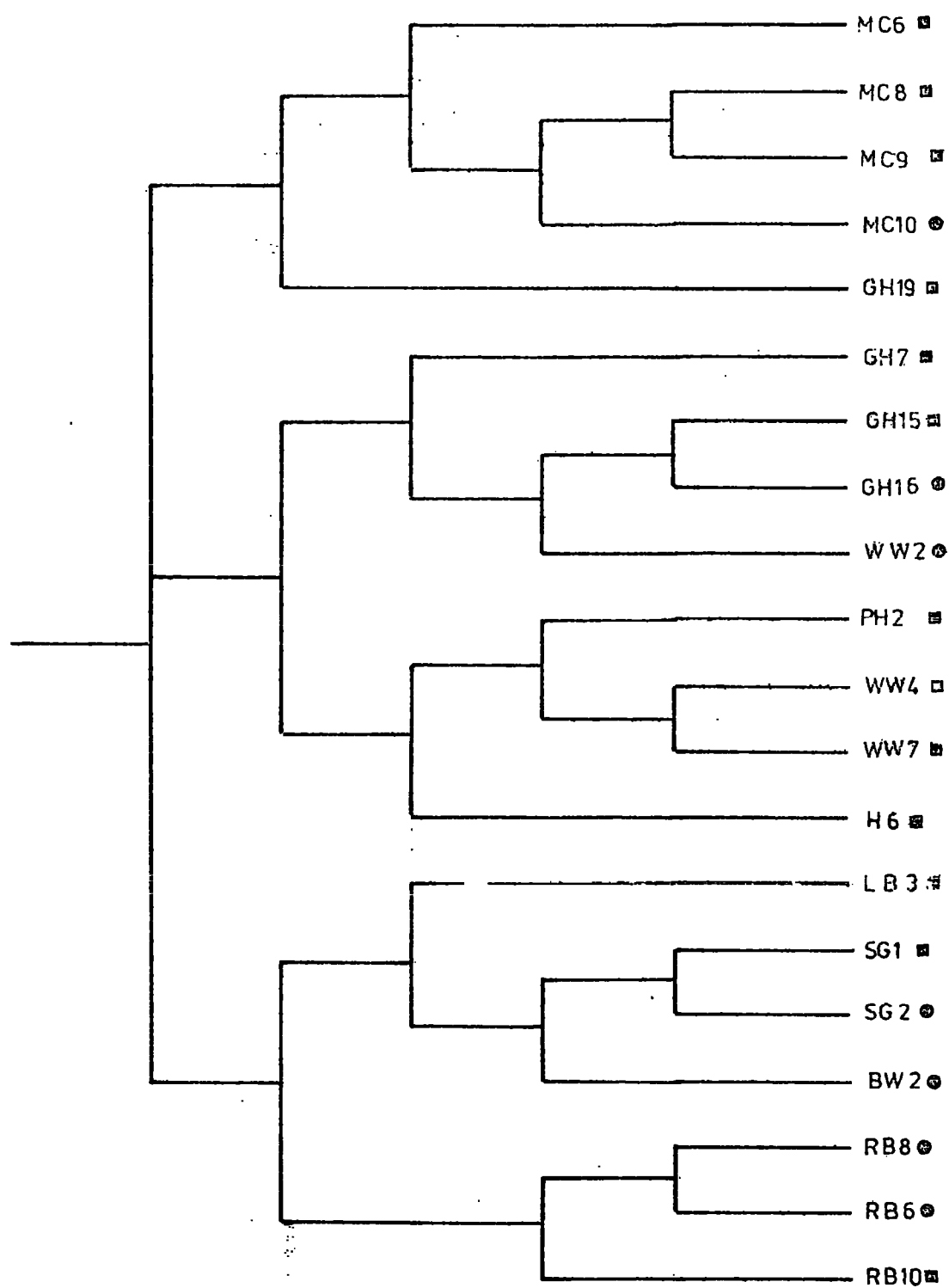

FIG 4,6

Dendrogram of the 1971 active(■) and visited(●) setts.

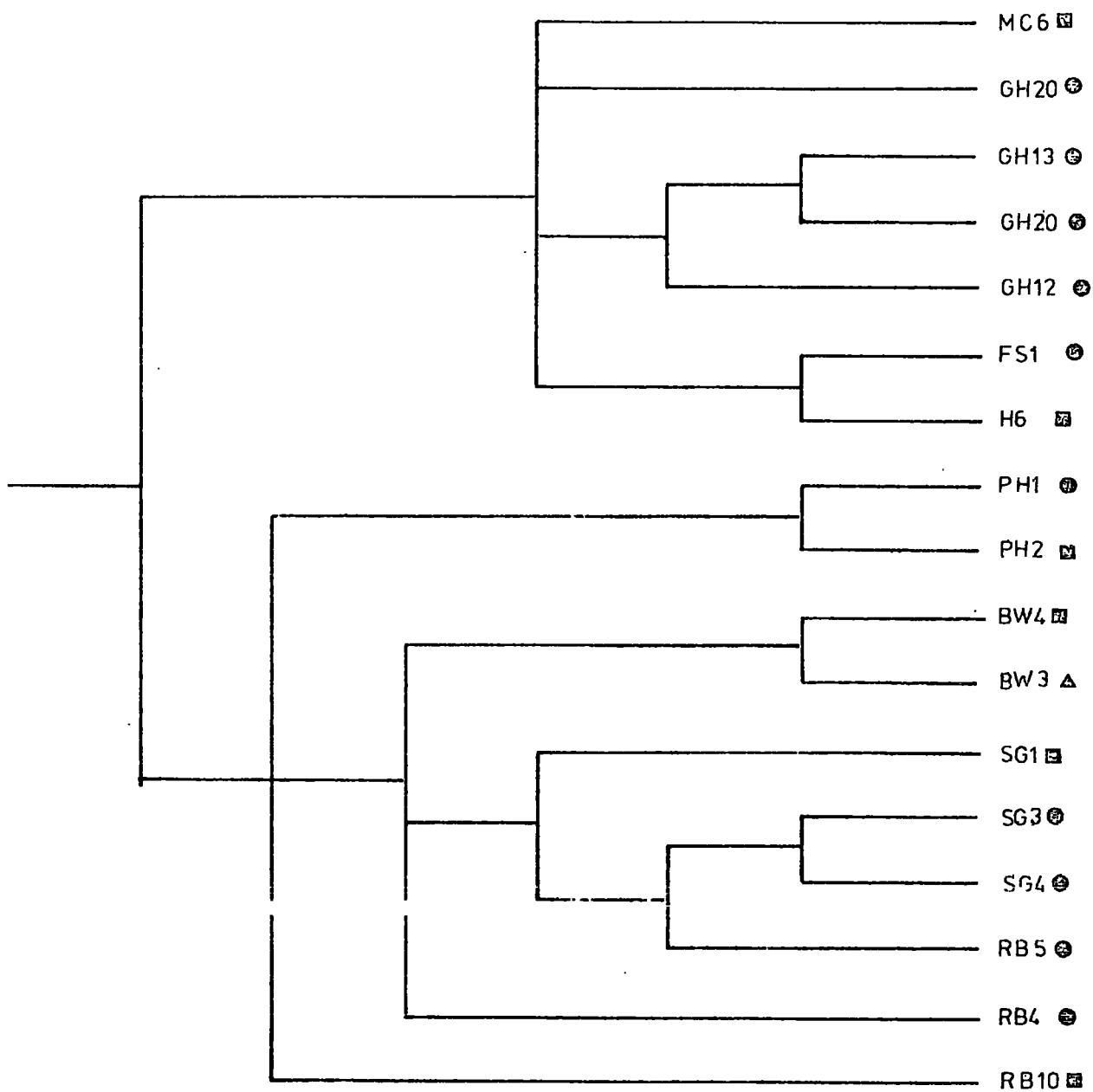

FIG4,7

Dendrogram of the 1968 breeding(▲), active(■) and visited(⊕) setts.

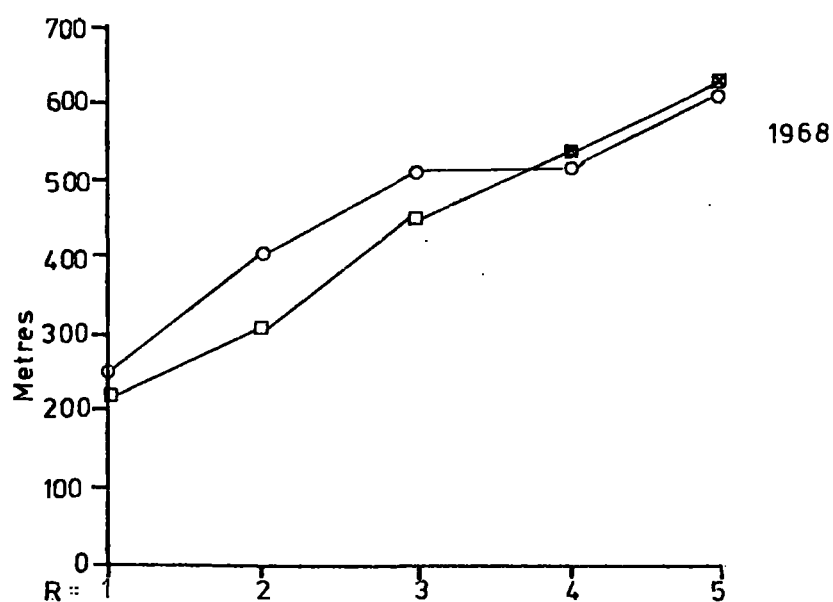
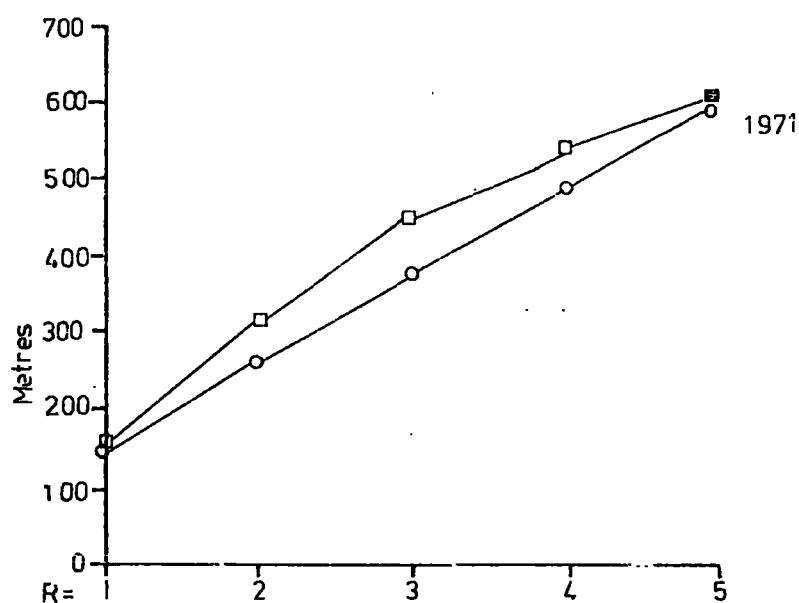
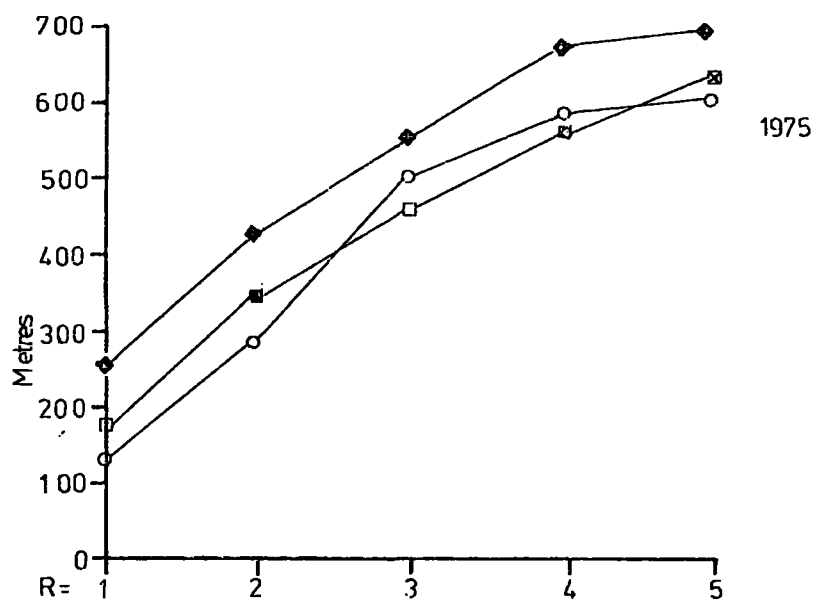

FIG 4.8

The first five mean near neighbour distances for 1975, 1971 & 1968.

■/◇ < p 0.05, □ 0.05 < p < 0.10 ; Probability that random is different from observed.
(○ = observed, □ = Type 1 random, ◇ = Type 2 random.)

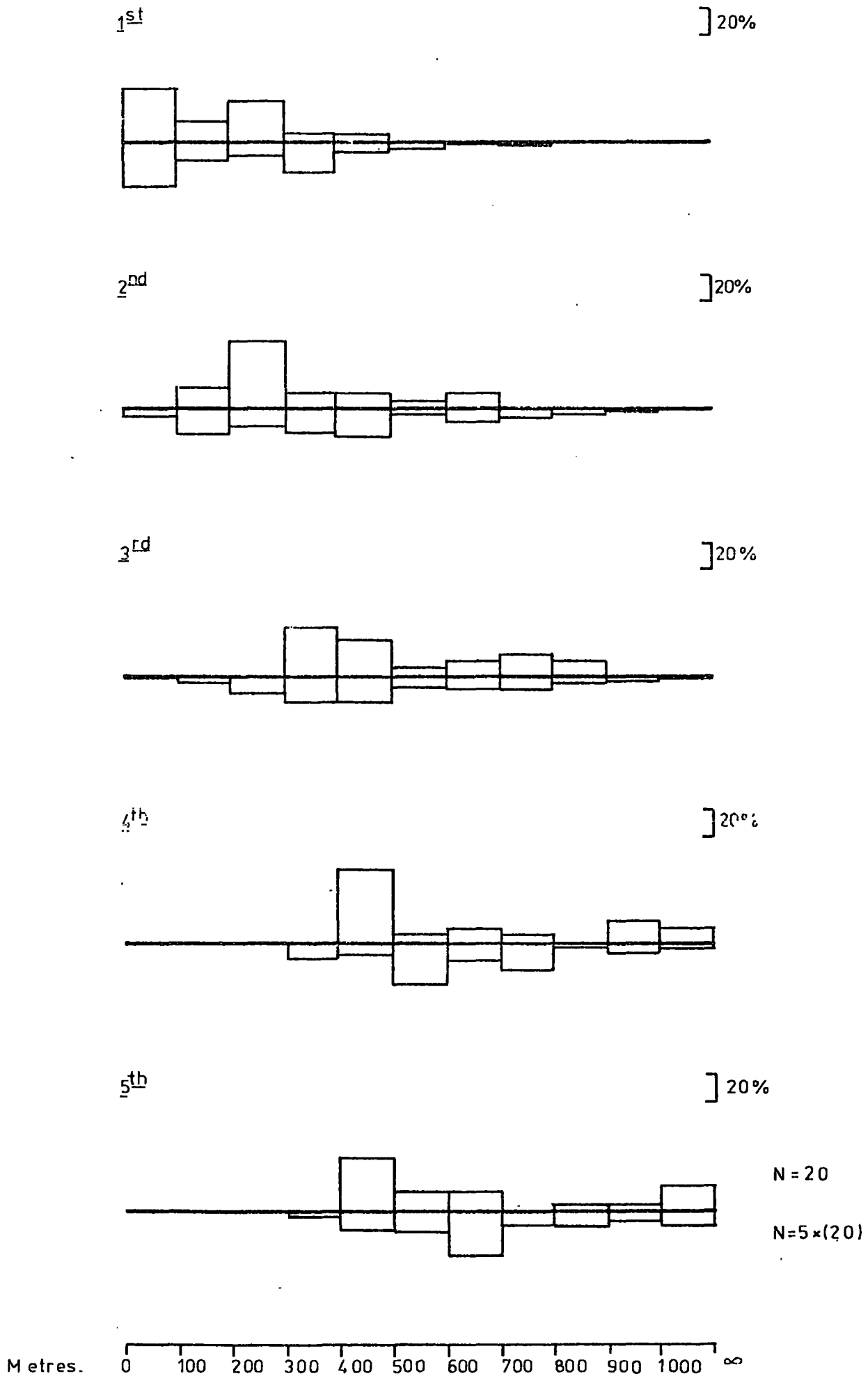

FIG. 4.9. The 1975 visited, occupied & breeding setts (upper), compared with type one random (lower)

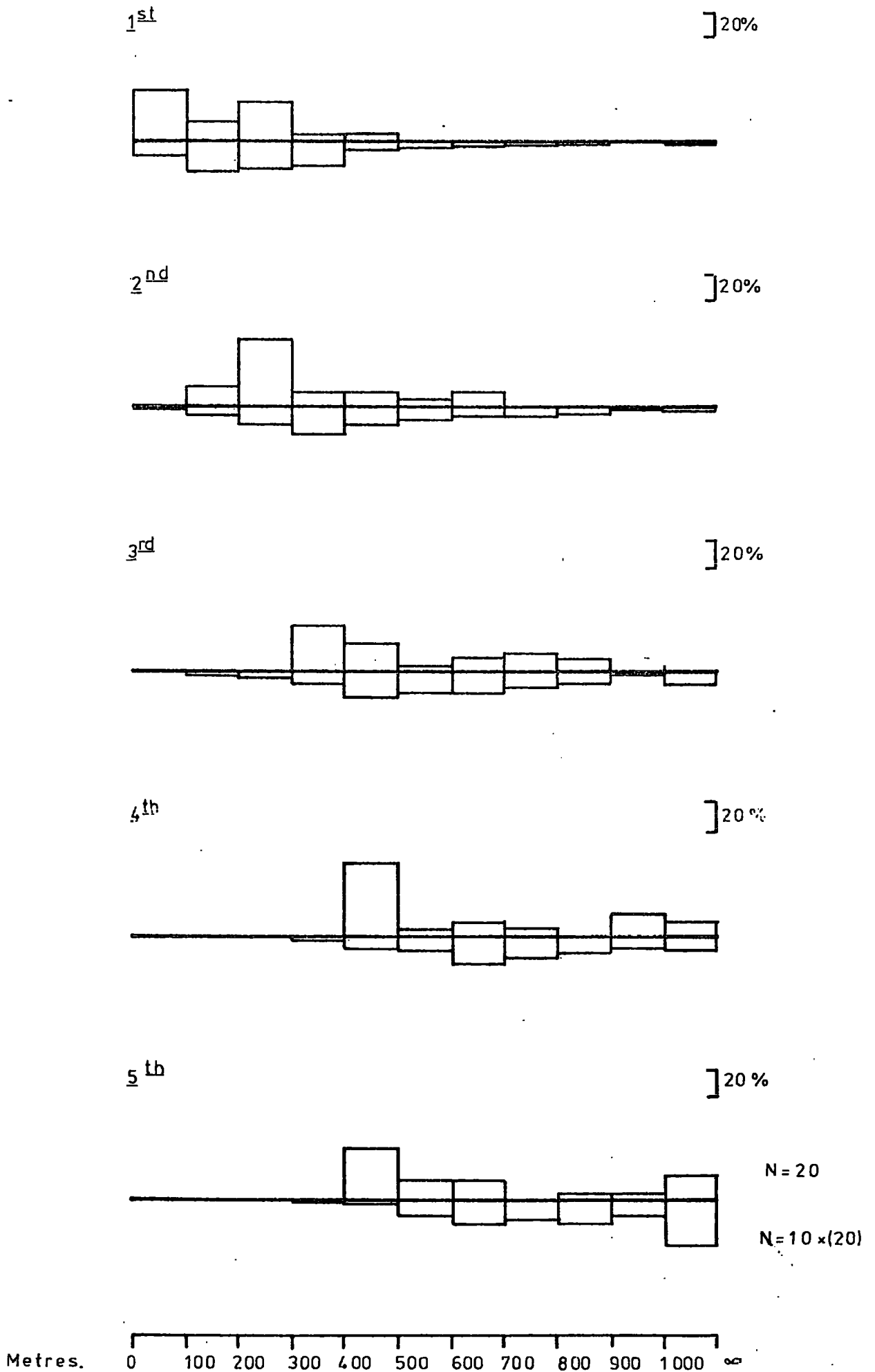
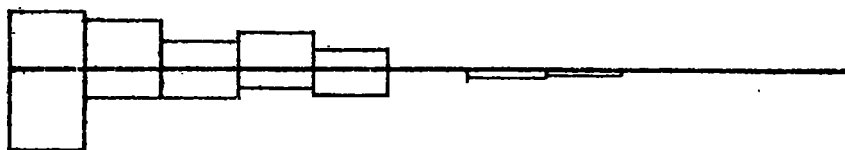

FIG. 4.10. The 1975 visited, occupied & breeding sets (upper), compared with type two random (lower).

1st

] 20%



2nd

] 20%

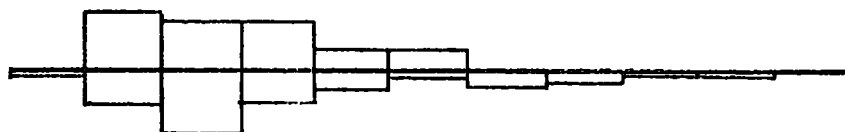

3rd

] 20%

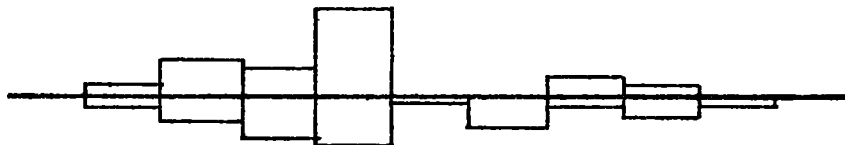

4th

] 20%

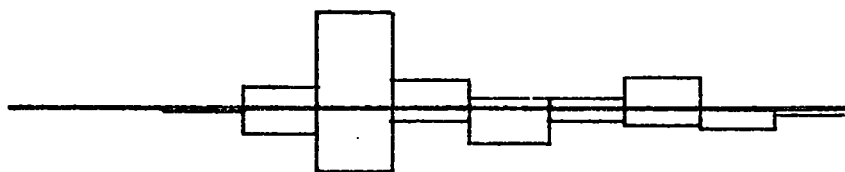

5th

] 20%

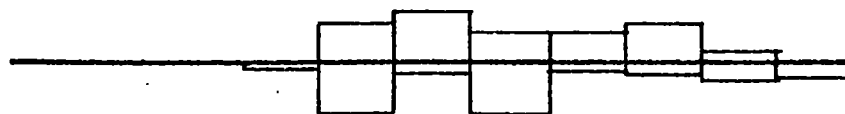

N = 20

N = 5 × (20)

Metres. 0 100 200 300 400 500 600 700 800 900 1000 ∞

FIG. 4.11. The 1971 visited, occupied & breeding setts (upper), compared with type one random (lower).

1st] 20%

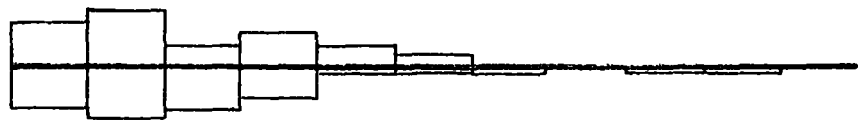

2nd] 20%

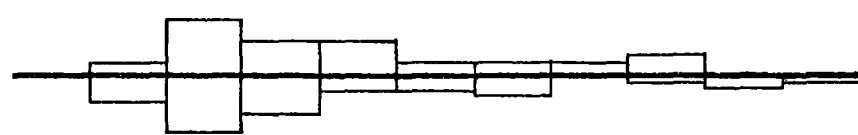

3rd] 20%

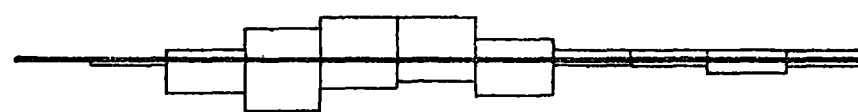

4th] 20%

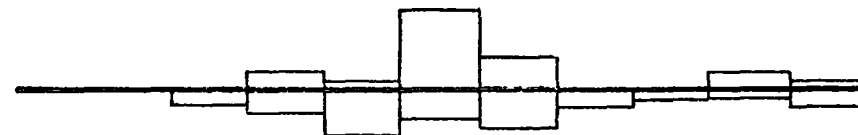

5th] 20%

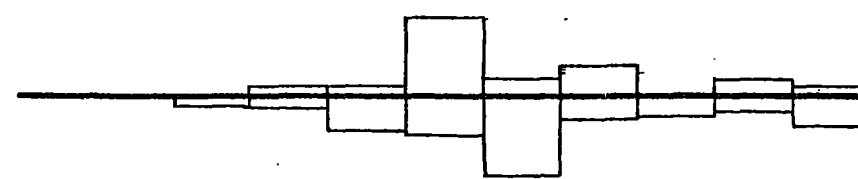

N=17

N=5*(17)

Metres. 0 100 200 300 400 500 600 700 800 900 1000 ∞

FIG. 4.12. The 1968 visited, occupied & breeding sets (upper), compared with type one random (lower).

4. iii.

d. Discussion.

The results show that not only does the spatial distribution differ from random and change from year to year, but also the distribution and the changes in time are complex. The near neighbour distances of the occupied and breeding setts are greater than the type one random distances in 1968, and to a certain extent are greater than the type one random distances in 1975. Even spacing, which is a consequence of greater than random near neighbour distances, has been noted in the distribution of setts in Wytham Wood, near Oxford (Southern, 1964). The distances, between these setts, have more recently been analysed by H. Kruuk (pers. comm.). His results show significant overdispersion, the mean near neighbour distance being 600 m; however this comparison was made with random distances; calculated on the assumption of a uniform habitat (see p.51).

The near neighbour analysis and the dendrograms, both of which included visited as well as occupied breeding setts, show grouping of the setts. Both these methods of analysis give group sizes in the range two to four. The results of the near neighbour analysis and the dendrograms are similar in 1975 and 1975, but not in 1968 where the near neighbour analysis gives a group size of four, and the dendrogram gives a mean group size of four, and the dendrogram gives a mean group size of 1.9. This difference is probably due to higher order groups being missed on the dendrogram (see p.56); the higher figure, of four, is more likely to be correct. The groups of setts, with a few exceptions, consist

of a large occupied or breeding sett, surrounded by one or more smaller visited or occupied setts. This pattern may be described as a main sett, surrounded by a satellite sett or setts. The definition of a sett, used in the present study (section 3.1, p.8), was only intended to indicate physical separation. It is suggested that the setts are aggregated, even though the first near distances of the visited, occupied and breeding setts are not significantly less than the type one random first near neighbour distances. Although there are no behavioural studies in depth of interactions between badgers of neighbouring setts, anecdotal evidence, e.g. from Neal (1948), and personal observation suggest that there are frequent social interactions, between badgers of neighbouring setts. Hence it is suggested that the aggregated groups represent social units.

The fourth and fifth near neighbour distributions of the visited, occupied and breeding setts show peaks in the range 400 - 599 m.; these peaks are not present, in either the type one random (all surveys), or the type two random (1975) fourth and fifth near neighbour distributions. The peaks in the observed near neighbour distributions suggest that there is a tendency towards regularity, despite the fact that only the 1975 mean fourth near neighbour distance is significantly greater, than the corresponding mean random near neighbour distance.

Regularity in spacing is a consequence of competition¹,

1. See p. 49 for other examples of spatial distributions in vertebrates.

which is usually brought about by agonistic behaviour. However I have not either in the field, or referred to in the literature any agonistic behaviour between badgers of neighbouring sett groups. The probable mechanism of competition is scent marking, using the periferal latrines. H. Kruuk (pers. comm.) found that when badgers were fed food, labelled with plastic markers, the markers appeared in the latrines, marking the boundary between the sett groups, to which the food was fed. Eisenberg and Kleiman (1972) in a review of olfactory communication in mammals note that when scent marking is used, boundary disputes are infrequently observed. The reasons for the observed spacing will be considered later (see Section 6, p.90), in the light of evidence from the analysis of diet.

The spatial pattern shows changes in time. The near neighbour distances of the occupied and breeding setts, change from greater than random in 1968, to almost random in 1971, to slightly greater than random in 1975. The mean group sizes shown by the dendrograms change from 1.9 in 1968, to 3.3 in 1971, to 2.2 in 1975. Although the figures from the near neighbour analysis of the visited, occupied and breeding are at variance with the dendrogram figures, there is certainly an increase in group size in 1971, compared with both 1968 and 1975. The peaks in the observed fourth near neighbour distributions show a shift from 500 - 599 m. in 1968, to 400 - 499 in 1975 and 1971, though the peak is less prominent in the latter year. It would seem that the spatial pattern is changing in a coherent manner, possibly in response, to food availability or to interference with the setts i.e. digging or grassing. These explanations

will be discussed further (Section 6, p. 97), in the light of evidence from the analysis of diet.

5. i.

DIET

INTRODUCTION.

Food is a possible determinant of habitat selection in badgers (Section 4.i, p.22), and hence it is relevant to study the food of the badger within the study area. Most mammals take a range of food items, although there are a few examples of mammals where the range is restricted by diet e.g. the koala, Phascolarctos cinereus, which feeds exclusively on various species of Eucalyptus (Ewer, 1968, p.29). Mammals are constrained in their choice of food by their dentition, their digestive system and physical build. Early learning also plays an important part in adaptive changes within these limits. Ewer (op. sit.) gives many examples of such changes.

There have been few studies on the feeding behaviour of the badger, for reasons already stated (p.1), however there are many anecdotal descriptions e.g. Neal (1948) describes badgers feeding on a wasp's nest. The main method of acquiring data on the badgers diet has been the examination of faeces, e.g. Neal (1948), Bradbury (1974) and Notini (1948). Badgers tend to eat only the soft parts of mammals and birds, e.g. carefully skinned hedgehogs have been stated to be a sign of the badgers presence in an area (Southern, 1964); hence bones and large pieces of fur or feathers are unlikely to appear in the faeces. Therefore careful examination of single hairs and parts of feathers, by the use of Day's (1966) key, is likely to give a better indication of the contribution of vertebrates to the badger's

diet. Plant epidermal fragments have also been examined, since by an analogous argument to the above, this method is likely to give a better indication of the contribution of fleshy plants to the badger's diet.

5. ii.

METHODS.

The samples were collected from latrines located ten and seven metres from the setts H6 and RB8 respectively, the locations of which are shown on map 2.1 (p.6). The latrines were inspected, and the scats if any, were collected at approximately weekly intervals between the dates 15:5:1975 and 30:8:1975 for the sett H6, and between the dates 15:6:1975 and 30:8:1975 for the sett RB8. Samples were found on all of the 16 occasions that the sett H6 was visited, and on seven of the eleven occasions that the sett H6 was visited. The numbers, the condition, and the dates of collection of the scats are given in Appendix 6.

The method that follows was adapted from MacDougall (1975) and Voth and Black (1973). On collection the scats were preserved by freezing. When required for analysis, they were thawed in 70% ethanol, so as to dissolve the pigments in the plant epidermal fragments. The sample was then suspended in the 70% ethanol, and passed through a 0.5 mm (square hole side) nylon sieve. The material retained by the sieve was sorted with the aid of a binocular microscope. The sieve retained such material as whole plant fragments, fibrous plant material, soil, earthworms, insects, parts of feathers, hair and bone. A record was made immediately of the macroscopic invertebrate remains. The vertebrate remains were kept for later analysis.

The hair and feather fragments were identified with the aid of Day's (1966) key. These were cleaned in 70% ethanol. Whole mounts were made in Berlese solution. And in

addition the individual hairs were sectioned by hand, with the aid of polyporous strip. Gelatine casts of hair were made according to Day's (1966) method. Reference slides of badger hair were prepared by the above methods, since badger hair was not included in Day's (1966) key.

Photomicrographs of these slides are shown in Appendix 2.

The material which passed through the sieve was centrifuged at approximately 2,000 r.p.m. for 60 seconds and re-suspended in 10% wt/vol sodium hydroxide. The resulting suspension was placed in a boiling water bath for 30 minutes, centrifuged a second time, the sodium hydroxide decanted, and the sediment re-suspended in three times its own volume of distilled water. This suspension was spread on to 18 by 40 mm slides, and examined for fragments of plant epidermis. Any fragments of insect exoskeleton, or any earthworm chaetae were also recorded.

Any quantitative estimation, by faecal analysis, of the plant species consumed by an animal, requires data from feeding experiments on captive animals so as to determine the relative digestibility of soft and hard materials e.g. Voth and Black's (1973) study on Canadian mountain beavers, or Stewart's (1968) study on East African ungulates. Hence in the present study each species of plant found, by faecal analysis, to be consumed was recorded as present or absent. The following technique was used for counting the fragments of epidermis of each species occurring on the slides. The material on / at least ten slides was counted, and the species present were recorded. Counting was then continued beyond this minimum until either all the material had been used, or five fragments of the least abundant species observed had been recorded; if all the material was used, all the species

present were recorded as such.

Reference photomicrographs were made (see appendix 4), of the epidermis of 30 species of herbs and grasses common in the area¹. The photomicrographs are either of simple wet preparations, cellulose casts (Rumex acetosa and R. conglomerata), or of specimens soaked in 70% ethanol, to remove pigments from the epidermis (e.g. Juncus effusus). Also there were available a selection of photographs, prepared for a study on Roe Deer by Linton (unpublished), which showed the epidermis of grasses, common mosses, and the leaves of common trees. From these photographs and those mentioned above a brief key, which is given in Appendix 4, was prepared.

The difference in frequency of the items which occurred in the faeces, were compared using the chi² test. Since the sample was small, and in the case of a single species there was a two by two contingency table, the exact chi² test (Bailey, 1959) was used. For comparisons of more than one species the chi² distribution was used. The probability was calculated from the formula below:

$$p = \frac{(A + B)! \cdot (C + D)! \cdot (A + D)! \cdot (B + D)!}{N! A! B! C! D!}$$

$$N! A! B! C! D!$$

Where p is the associated probability, N is the sample size, and A, B, C, and D represent the frequencies of the different cells of the contingency table shown overleaf:

1. Nomenclature and identification from Keble Martin (1965).

A	B	A + B
C	D	C + D
A + C	B + D	N

In order to determine the origin of some of the items, such as Festuca which occurred in the faeces, an association matrix of all the species was produced. The probability of each association was calculated using the exact χ^2 test, as above. Fager's (1957) index of association was calculated, according to the formula below:

$$I_{AB} = \frac{2J}{n_A + n_B}$$

Where I_{AB} is the index of association, J is the number of joint occurrences, n_A is the number of occurrences of species A, and n_B the number of occurrences of species B. The statistical test on this index was not used, because the nature of the sample was inappropriate (Southern, 1966).

5. iii.

RESULTS.

Tables 5.1 and 5.2 show the contribution that each item made to the badger's diet, as shown by the analysis of the faeces. Table 5.1 gives the comparative diet of the two setts, RB8 and H6, and table 5.2 gives the occurrence of items in the diet for each month of the study; the raw data for these tables is given in Appendix 6. Table 5.3 shows the results, grouped so as to enable comparison with Neal's (1948) data (see p.88 for a discussion of this table). Fig. 5.1 shows the association matrix of the different food items found in the faeces, and the associated exact χ^2 probabilities are given in table 5.4, together with Fager's (1957) indices of association.

During the study four different unrecognisable fragments of plant epidermis were found. One bone, a femur of length 4.5 mm, was found. Although this was not identified per se, there was hair adhering to it, which was identified as Talpa. Soil was present in 30% (9) and fibrous plant material in 50% (15) of the samples.

There was no overall statistical difference between the food taken at each sett ($\chi^2 = 12.24$, d.f. = 20, $p = 0.94$). However individual items did differ: cereal

($p = 0.05$), and possibly Arvicola ($p = 0.08$). The data for all the food items, except cereal and Arvicola, was combined to analyse the difference in food taken in each month. There was a significant tendency for the amount of Sorex ($p = 0.03$), Apodemus ($p = 0.04$), and Oryctolagus ($p = 0.01$) to increase during the period of the study. The amount of Trifolium showed a significant peak in June ($p = 0.02$). The probabilities for all the monthly differences are given in table 5.2.

The association matrix (fig. 5.1) shows the significant associations found between species. Negative associations are shown, but should be interpreted with caution, because of the small size, and because of the heterogeneity of the habitat from which the "samples" were taken (Fager, 1957).

NUMERICAL OCCURRENCE OF ITEMS IN THE FAECES OF BADGERS; THE RESULTS ARE SHOWN FOR THE SETTS, H6 AND RB8, SEPARATELY AND COMBINED.

FOOD ITEM	H6	RB8	COMBINED	$p^1 =$
<u>Sorex.</u>	2	0	2	0.97
<u>Apodemus.</u>	3	0	3	0.74
<u>Talpa.</u>	2	0	2	0.97
<u>Arvicola.</u>	0	2	2	0.08
<u>Oryctolagus.</u>	2	1	3	0.74
Earthworm.	11	3	14	0.91
Insect.	6	2	8	0.67
<u>Endymion.</u>	5	1	6	0.95
<u>Allium.</u>	4	1	5	0.73
<u>Rumex.</u>	9	3	12	0.72
<u>Plantago.</u>	5	3	8	0.58
<u>Trifolium.</u>	8	2	10	0.93
<u>Luzula.</u>	7	1	8	0.67
<u>Juncus.</u>	2	2	4	0.50
<u>Festuca.</u>	11	4	15	0.91
<u>Deschampsia.</u>	5	1	6	0.95
<u>Bromus.</u>	8	2	10	0.93
<u>Poa.</u>	1	1	2	0.97
Berries.	2	1	3	0.74
Root (conifer).	2	0	2	0.97
Cereal.	1	3	4	<u>0.04</u>
SAMPLE SIZE.	22	7	29	-

The following items occurred only once: Quercus pollen, at such a density as to have come from eating the flowers (15:5:75), and a passeriform feather(12:6:75), from H6; a moss fragment (2:8:75) from RB8.

1. The probability, from the exact χ^2 , of the food taken at the two setts being different in composition.

TABLE 5.2.

THE MONTHLY OCCURENCE OF FOOD ITEMS IN THE FAECES OF BADGERS, FOR THE SETTS H6 AND RB8, COMBINED EXCEPT FOR ARVICOLA AND CEREAL (SEE P. 79). DATES OF COLLECTION ARE SHOWN IN APPENDIX 6.

FOOD ITEM	MAY	JUNE	JULY	AUGUST	p(CHI ²)*	p(TAU) ⁺
<u>Sorex.</u>	0	0	0	2	0.13	0.03
<u>Apodemus.</u>	0	0	1	2	0.33	0.04
<u>Talpa.</u>	0	1	0	1	0.71	0.35
<u>Oryctolagus.</u>	0	0	0	3	0.03	0.01
<u>Arvicola.</u>	H6 0	0	0	0	-	-
	RB8 -	0	1	1	0.62	0.12
Earthworm.	3	5	3	3	0.26	0.07
Insect.	0	4	2	2	0.57	0.50
<u>Endymion.</u>	2	1	2	1	0.17	0.16
<u>Allium.</u>	0	2	2	1	0.76	0.44
<u>Rumex.</u>	1	4	2	5	0.48	0.19
<u>Plantago.</u>	1	3	2	2	0.98	0.37
<u>Trifolium.</u>	0	7	1	2	0.02	0.14
<u>Luzula.</u>	0	4	2	2	0.57	0.50
<u>Juncus.</u>	1	0	2	1	0.33	0.43
<u>Festuca.</u>	2	7	3	3	0.40	0.07
<u>Deschampsia.</u>	1	1	3	1	0.44	0.46
<u>Bromus.</u>	0	5	2	3	0.39	0.42
<u>Poa.</u>	0	0	2	0	0.13	0.32
Berries.	0	1	2	0	0.37	0.45
Root (conifer).	0	1	1	0	0.71	0.35
Cereal.	H6 0	1	0	0	-	-
	RB8 -	1	2	0	0.25	0.43
SAMPLE SIZE	H6 4	8	5	5		
	RB8 -	2	3	2		
TOTAL SAMPLE	4	10	8	7		

* Chi² test probability.

⁺Probability associated with Kendal's Tau.

OCCURRENCE OF FOOD ITEMS, GROUPED SO AS TO ENABLE COMPARISON WITH NEAL'S (1948) DATA. BOTH NEAL'S (1948) DATA AND THE H6 DATA HAVE BEEN GROUPED BY MONTH. THE H6 DATA HAS BEEN COMBINED INTO "BROAD" FOOD TYPES.

FOOD ITEM	HOLLINGSIDE 6.					NEAL (1948)				
	MAY	JUNE	JULY	AUG.	TOTAL	MAY	JUNE	JULY	AUG.	TOTAL
MAMMALS.	1	1	1	5	8	0	1	2	4	7
BIRDS.	0	1	0	0	1	0	0	0	0	0
INSECTS.	1	3	1	1	6	1	1	1	6	9
EARTHWORMS.	4	1	2	2	9	0	0	0	0	0
VEGETABLES.	4	8	4	4	20	2	1	1	1	5
CEREAL.	0	1	0	0	1	0	0	0	3	3
SAMPLE SIZE.	4	8	5	5	22	2	3	3	8	16

TABLE 5.4.

FAGER'S (1957) ASSOCIATION INDICES (SEE P. 77), AND THE EXACT CHI² PROBABILITIES FOR THE SPECIES PAIRS, INDICATED ON FIG. 5.1.

SPECIES PAIR	PROBABILITY.	INDEX OF ASSOCIATION
Fibre : <u>Festuca.</u>	0.041	0.50
Cereal : <u>Plantago.</u>	0.049	0.50
Cereal : <u>Earthworm.</u>	0.042	0.44
Root (conifer): <u>Luzula.</u>	0.068	0.40
Berries : <u>Deschampsia.</u>	0.094	0.44
Berries : <u>Earthworm.</u>	0.099	0.35
<u>Poa</u> : <u>Deschampsia.</u>	0.036	0.50
<u>Poa</u> : <u>Luzula.</u>	0.068	0.40
<u>Bromus</u> : <u>Luzula.</u>	0.046	0.55
<u>Bromus</u> : <u>Rumex.</u>	0.080	0.15
<u>Deschampsia</u> : <u>Earthworm.</u>	0.063	0.50
<u>Festuca</u> : <u>Apodemus.</u>	0.099	-
<u>Luzula</u> : <u>Plantago.</u>	0.047	-
<u>Luzula</u> : <u>Rumex.</u>	0.054	0.09
<u>Trifolium</u> : <u>Insect.</u>	0.056	0.55
<u>Plantago</u> : <u>Insect.</u>	0.047	-
<u>Allium</u> : <u>Insect.</u>	0.099	0.46

- Negative Association (Fager's (1957) index of association does not apply to such associations).

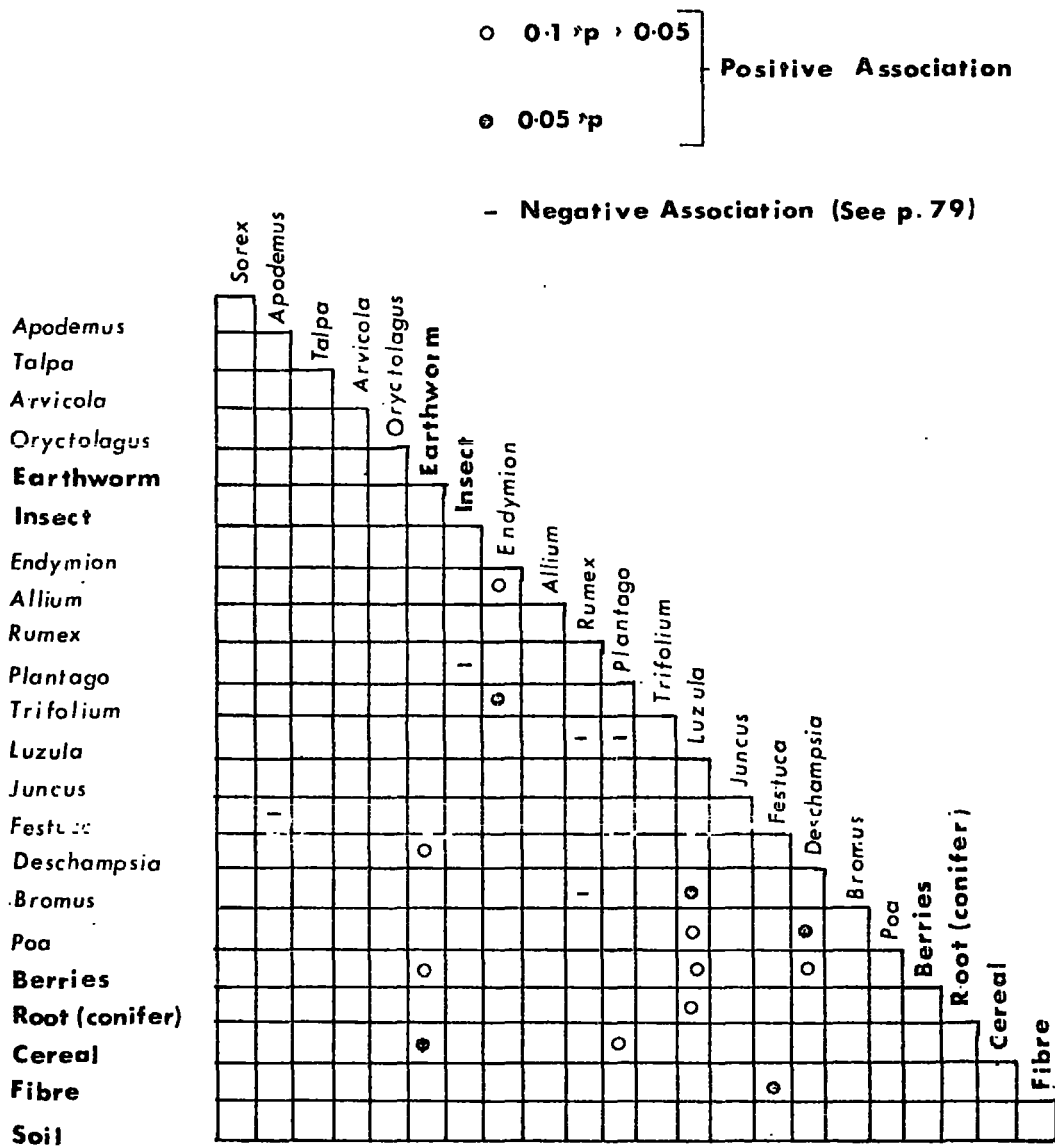

FIG 5.1. The Association Matrix of Items Found in the Faeces. The indices of association (Fager, 1957) and probabilities are given in table 5.4.

5. iv.

DISCUSSION.

The data confirm that a wide variety of food is taken by the badger, over the summer months. This fact has been observed by several authors e.g. Neal (1948), Andersen (1954), Likhachev (1956) and Bradbury (1974).

Sounds of eating hard food are often heard when badgers are feeding, and it is commonly supposed, that these sounds are due to badgers eating snails or slugs.

However neither radulae nor fragments of shell were found in the scats examined in the present study. Bradbury (1974) found only one scat, in a sample of 800, which contained a fragment of shell. The shell in this sample was poorly digested, hence the absence of slugs and snails, in the present study, is unlikely to be an artefact. Wasps are also considered to be a common constituent of the badgers diet, and there are many descriptions of badgers raiding wasp's nests e.g. Neal (1948) and Soper (1955). No remains of wasps, either adults or larvae, were found in the scats examined in the present study. However a recently raided wasps nest was found in the ground of the vet's house; and there were very few extant wasp's nests in the study area, and those nests which were present tended to be out of reach of badgers. Although there are many anecdotal accounts, from reliable observers, of badgers eating food from the

dustbins of the colleges and the school of agriculture (for positions see map 2.1, p.7), no remains that could be attributed to this source were found in the scats examined in the present study.

Epidermal fragments and whole pieces of plants appeared frequently in the scats. These remains came from plants, which fall into two classes: first, the fleshy plants such as Endymion, Allium and Rumex (probably R. acetosa); second, the fibrous plants such as Festuca, Deschampsia, and Juncus. The fibrous plant material, which was found in the scats, was of uncertain origin, there being only one significant association with a plant, containing a large amount of fibre i.e. with Festuca (see Fig. 5.1). The fibrous plant material could be taken incidentally whilst rooting around for earthworms or insects, whilst collecting bedding, or for the same obscure reason, that domestic carnivores often eat grass. The only association, that would support the first hypothesis, is that of Deschampsia with earthworms; however this association is not significant ($p = 0.063$, table 5.4). Since the badgers digestive system is not adapted for hard vegetable material, it seems likely that the fibrous material is taken for one or other of the above reasons;

however there is no evidence as to which. There are no significant differences in the nature of the vegetation, either individually or grouped, that was taken at two setts. However Endymion, Luzula and Deschampsia tend to occur in a greater proportion of the samples from H6 than from RB8; these differences probably reflect the different abundances of these species surrounding the two setts. The changes shown in the amount of Trifolium and possibly in the amount of Festuca could reflect the changes in palatability of these species.

The main animal foods taken are earthworms, insects and mammals, in order of decreasing numerical abundance. Arvicola and Talpa are not usually considered as being components of the badger's diet; their inclusion may be due either to the nature of the methods used in the present study (p.72), or to the nature of the habitat. I have seen no reference in the literature to Arvicola being taken by badgers, however Soper (1955) gives an anecdotal description, and a series of sketches, of a badger eating a mole. The only bone found was small (p.78) and was tentatively identified as Talpa. The size was such, that it may have been from an animal taken from the nest. The phenomena of badgers taking mammals from the nest has been noted by Bradbury (1974). He found

that the size of Oryctolagus scapulae found in the scats was such as to have come from animals taken from the nest

The monthly figures (table 5.2) show a possible tendency for the numbers of earthworms, found in the scats, to decrease over the the summer months ($p = 0.07$); this tendency has also been observed by K. Bradbury (pers. comm.). There is a significant tendency for all mammals, except Arvicola, to increase during the course of the summer. Neal (1948) found a similar tendency for the numbers of mammals found in the scats, in his case Oryctolagus, to increase during the summer months. The summer of 1945, during which Neal's 1948 data was collected, was dry and the study area was much further south than Durham. It seems likely that the number of earthworms eaten by the badger is influenced by the weather, since the latter months of the present study were also dry; a likely reason for the change in the numbers of earthworms taken is the progressive dessication of the ground, over the summer months. However insufficient data was available to test this hypothesis in the present study.

The latrines from where the scats were collected were both close to their respective setts. Middleton and Paget (1974) found that, from June to October

inclusive, the latrines in the immediate vicinity of the sett were used very much less often than those 30 and 100 yards away. This phenomena, if operating in the present study area, would not only explain why so few scats were available, but would imply that the results are biased towards the sow and cubs, in the case of H6; since H.Kruuk (pers. comm.) found, from radio-tracking data, that the periferal latrines were used as territorial markers.

The availability of food, the possibility of shortage, and the badger's requirements are considered in the final discussion (p. 93).

DISCUSSION.

The analysis of the spatial distribution gives information, which relates to the home range of the badger. Home range has varied significance, according to the use that a particular species makes of its habitat. The most significant aspect of home range in the context of the present study is the core area, as described by Jewell (1966), which is the part of the range used most by a species, and is associated with such features as regular runways and burrows. A wider definition of the badger's range would have needed to include such aspects as seasonal expansion or contraction of the range, and would have required at least a year's data. If it is assumed that the badger's range is circular and of radius 400 m (see p. 69), then the spatial analysis would indicate that the area of the range is 50 hectares (124 acres). It is unlikely that badgers cover any much greater area when feeding, since there are differences, albeit small, in the food taken at the two setts studied in the analysis of diet, these two setts being 1.2 km apart.

It is difficult, without behavioural evidence, to determine whether or not the range is exclusive i.e. whether or not the range represents a territory. H. Kruuk's (pers. comm.) data given on page 70, would support the idea of the range being exclusive, for at least part of the year; a suggestion as to the mechanism of exclusion is also given on page 70. If badgers from neighbouring sett groups are in fact excluded from the range, then it is likely that some resource is being defended, rather than that there is any competition for suitable sett sites, since these are present in excess (see p. 22

The resource that is most likely to be defended is the feeding areas; if these are defended then food in some circumstances might be in short supply. Hence the possible productivity of the area and the biomass of the badgers supported are considered.

The study area area of five square kilometres supports 20 adult badgers. If Southern's (1964) figures of mean weight (see p. 1) and an equal sex ratio are assumed, then the biomass is likewise 460 g / hectare. The exact agreement between the two estimates biomass is coincidental; but the fact that the biomass in both instances is in the range 400 to 500 g / hectare is likely to be significant. These figures may be compared with those for other similar sized mammals for example Taxidea taxus (the North American badger), which is a pure carnivore (Sergeant and Warner, 1972) and has a biomass of 62 g / hectare (Mohr, 1947), Mephitis mephitis (the striped skunk), which has a similar diet to the badger, and has a biomass in the range 82 to 318 g / hectare (Verts, 1967), and Castor canadensis (the Canadian mountain beaver), which is a herbivore (Voth and Black, 1973) and has a biomass of 6,300 g / hectare (Fitch, 1958). The figures above serve to illustrate that at each trophic level, there is less production available to the trophic level above, than was available from the trophic level below. Hence primary carnivores will have a lower biomass than herbivores, and secondary carnivores. This implies that for a given individual weight, the territory size will increase with the trophic level.

From considerations which were similar to the

above Schoener (1968) and MacNab (1963) have derived formulae, which relate the home range or territory size to the weight of the animal or animals, that the home range or territory size to the weight of the animal or animals, that the home range or territory supports. Schoener's (1968) formula given below relates territory size of carnivorous carnivora to their weight.

$$TS = 0.020 W^{1.41}$$

Where TS is the territory size in acres¹ and W is the weight in grams. If the weight of a single (12 kg) badger is entered into the above formula, then the resultant territory size is 4,570 hectares.

This figure is considerably greater than that found, and would correspond to a circular territory of radius 3.8 km. MacNab (1963) describes two feeding classes of croppers and hunters; these feeding classes correspond to herbivore / graminivore, and omnivore / carnivore respectively. By the term hunter, MacNab (1963) means an animal that actively searches for its food, rather than a carnivore. The list of species, and their classifications, taken from MacNab (1963) are given in appendix 7. MacNab's (1963) formulae are given below:

$$R \text{ (cropper)} = 12.6 W^{0.71}$$

$$R \text{ (hunter)} = 3.02 W^{0.69}$$

Where R is the area of the range in acres, and W is the weight in kilograms. The resultant range sizes are 12.6

1. Formulae are given in their published form, and later converted into metric units.

hectares (cropper) and 55.3 hectares (hunter), for a pair (12 & 11 kg) of badgers. The observed figure was 50 hectares (see p. 90), for a pair of badgers (12 and 11 kg.)

Thus the predictions of the above formulae would indicate that the size of the badger's range is consistent with that of an omnivore, consistent with that of an omnivore.

There are various methods for estimating the energy requirement of a mammal, see Golley, Petruszewicz and Ryszkowski (1975) for a review. Estimates have been based on the basal metabolic rate (BMR), the resting metabolic rate (RMR) and the average daily metabolic rate (ADMR). The BMR is the rate of energy utilisation of an inactive animal animal at thermoneutrality. The RMR is the rate of energy utilisation at ambient temperatures; effectively it is the BMR plus a thermoregulatory component. The ADMR is the rate of energy utilisation of an active animal, at field temperatures, averaged over a 24 hour period. There is no data available on the badger's ADMR, and there is insufficient behavioural data available for an estimate to be made. Hence the badger's energy requirement is calculated on the basis that it is equal to the BMR, whilst the badger is in the sett, and that it is equal to twice the BMR (Brody, 1945) plus a thermoregulatory component, whilst the badger is outside the sett.

Iversen (1972) gives a formula for the basal metabolism of mustelids, weighing more than one kilogram. The formula is given below:

$$M = 84.6 W^{0.78}$$

Where B is the basal metabolic rate in kilocalories per day (kcal / day), and W is the weight in kg. Thus the basal metabolism of a 12 kg. (male) badger would be 588 kcal / day, and the basal metabolism of an 11 kg. (female) badger would be 549 kcal / day. The thermoregulatory component may be calculated from the thermal conductance (TC), which is the relationship between metabolism and ambient temperature. The following formula is taken from Golley, Petruszewicz and Ryszkowski (1975, p. 199):

$$TC = 0.01094 W^{-0.499}$$

Where TC is in kcal / day per °C, and W is in grams. Hence for a 12 kg. (male) badger and for an 11 kg. (female) badger, TC is 11.87 kcal / day per °C and 11.38 kcal / day per °C respectively. If an average ambient temperature of 8°C is assumed, then the rate of metabolism for thermoregulation is 142 kcal / day for a 12 kg. (male) badger, and 137 kcal / day for an 11 kg. (female) badger. If it is assumed that the badger spends, on average, half its time outside the sett, then the daily energy requirements of a pair of badgers is approximately 1,980 kcal / day.

The ratio assimilation / consumption varies according to such factors as life cycle, condition and type of food, and environmental temperature (Petrusewicz and McFadyen, 1970); there is also considerable variation between individuals of any one species (Wiegert, 1965). However information from zoo diets (Altman and Dittmer, 1968) for Melivora capensis leuconota (the Honey Badger)¹ gives a figure of 0.76

1. M. capensis is a member of the Melivorinae, a group closely related to the Melinae (Ewer, 1973).

for assimilation / consumption. It is likely that this figure would vary with the particular diet of wild animals, since wild animals may at time take more vegetation, than is fed to captive animals; however the above figure is assumed. Thus the energy requirement for a pair of badgers, from a range of 50 hectares (see p. 90) is 2,605 kcal / day, which is equivalent to 52 kcal / day per hectare of the range.

For reasons given on page 75 it was not possible to estimate how much vegetation was taken; the same problem also applies to small mammals, insects and to a lesser extent earthworms. The energetics of earthworms as a badger food will therefore be considered in detail. McDonald (1976), using infra-red night viewing equipment, in mixed woodland, observed badgers feeding at a rate, averaged over the night, of six earthworms per minute. The mean weight of earthworms in mixed woodland, as determined by the formalin method¹, is 0.54 g. (Wallwork, 1970). A live weight of of 0.54 g. correspond to a dry weight of earthworms of 0.099 g.; this dry weight corresponds to an energy value of 0.99 kcal (Satchell, 1971). At a feeding rate of six earthworms per minute, it would take a 12 kg (male) badger approximately five hours to consume sufficient earthworms, to fulfil its basal metabolic requirement. Since badgers are likely to select the larger of the earthworms, the above time

1. The methods consists of of spraying formalin onto the ground, and observing the number of earthworms to emerge. This method is more likely to reflect the numbers available to badgers, because it is biased towards the earthworms nearer the surface.

would probably allow a badger to fulfil its entire metabolic requirements.

In the present study area the biomass of earthworms is likely to be lowest in the arable land. Wallwork (1970) gives figures of 50 to 106 g/m² for arable land in North Wales. If the figures for the energy requirements of badgers (on the previous page) are used, then the badgers yearly energy requirement corresponds to 2% of the earthworm standing crop. Hence it is unlikely that there will ever be a shortage of earthworms in the ground; the main problem, for the badger, is likely to be one of availability.

The analysis of diet shows an increase in the number of small mammal remains found in the faeces, during the latter part of the summer. It is probable that this increase in the number of small mammals taken, represents a behavioural switch caused by progressive dessication of the ground and the consequent shortage of earthworms. It is suggested that earthworms are the preferred food of the badger, since earthworms were found in almost all the faecal samples, analysed during the earlier part of the study. The appearance of such species as Juncus in the faecal samples may indicate that badgers seek the damper ground, where such species grow, when earthworms are in short supply. If earthworms are in short supply in the summer months, then it would be expected that territorial behaviour would be most intense at this time; however

evidence indicates (A.Cheeseman, pers. comm.) that territorial behaviour is most intense during late winter and early spring. Hence it is likely that territorial behaviour is only secondarily, if at all, related to summer food supply.

It could be concluded that the pattern of dispersion of the setts changed between the three surveys. In 1971 the badgers appeared to be using more setts, than in 1968 or 1975, although the population had remained at a similar level in all three surveys (see p. 19). The setts showed less tendency to be overdispersed in 1971 (see fig. 4.4, middle histogram), and formed groups of size 1.9 in 1968, 3.3 in 1971 and 2.2 in 1975 (see p. 70). These results could indicate that in 1971 the intensity of territorial behaviour was less than in the other years, and that the group size was larger. Amongst the possible causes of the change in 1971 are the effects of gassing a large sett (the BW3, BW4 and BW5 complex) in 1968, and a change in the availability of food. The former explanation would seem unlikely, since a large sett (the Durham School sett) was gassed in 1972, with no corresponding change in spatial pattern. Earthworms are suggested as being an important food, and their availability is affected by the state of the ground. In this connection it should be noted that of the years, when the area was surveyed, 1968 was the driest¹, 1975 the next driest, and 1971 the least dry. This is the same order as the tendency to be overdispersed (see fig. 4.4). The relationship may

1. As based on the number of days when the ground was described as dry, in the University of Durham meteorological field station reports, for the 12 months preceding the study.

X

be coincidental, but is worth considering in the light of evidence from future surveys. One final suggestion, for which there is as yet no evidence, is that setts close to water, where breeding occurred in the present study area, are in effect "key" sites, and that there may be competition for their occupation. This idea may similarly repay further investigation.

Since, in the present study area, the amount of suitable habitat would appear to be in excess, the major limit on the number of active setts is the spacing of the setts; this spacing is influenced by the badgers social behaviour, which may be influenced by the availability of food. One factor which may affect the distribution of setts, which was not investigated, is ventilation. Vogel (1972) in a theoretical study on burrowing animals determined the oxygen reserve of Cynomys burrows, using King's (1955) data. He found that the Cynomys burrows contained sufficient oxygen for six hours, though the concentration of carbon dioxide would make the burrow uninhabitable before this time. Although badger setts are larger than Cynomys burrows, the oxygen reserve of a badger sett is likely to be less than the above figure, since the entrances of badger setts are of the same size as Cynomys burrows, and there is normally more than one animal, with a higher metabolic requirement, present in a badger sett. The need for air flow through the sett may explain why setts tend to be found near the the upper breaks of slope (see p. 47). It is noticeable

that in large setts such as H6, there are tunnels dug vertically upwards; these tunnels are of such a size that they could not be used as entrances. This arrangement is one suggested by Vogel (1972) as a means of ventilation for a burrow. Ventilation could be further investigated by measuring oxygen levels in burrows; for example oxygen levels have been found to be significantly lower in Spermophilus sp. (the ground squirrel) burrows, than outside the burrow (Studier and Procter, 1971), but the lowered oxygen levels were not related to ventilation. Since British woodlands are normally found on slopes that are unsuitable for cultivation (Rackham, 1976), a need for ventilation may better explain why setts tend to be found close to the edge of woodland than does a need for mixed feeding (see p. 46). The former explanation is unlikely, since agricultural land contains fewer earthworms than woodland (Wallwork, 1970)

The factors which influence the nationwide distribution of badgers, may be inferred from the factors found to affect the distribution of badgers in the present study area; although the order of importance may be different. One of the important factors affecting the nationwide distribution of badgers is the availability of suitable substrate. This may be observed if the Mammal Society distribution map¹ is compared with a soil map of Britain. The ten kilometre squares contain mostly chalk or sand soils. However the soil type does not entirely explain the distribution. The greatest discrepancies are to be

1. The 1974 map has only been published for limited distribution. A copy is included in appendix six.

found in mountainous areas, and in East Anglia, where there has been a decline in badger numbers over the last two decades (Jeffries, 1965). The former discrepancy is probably caused by a lack of observers. The latter discrepancy is probably in part due to the high water table in the fens; however the recent decline is probably caused by the destruction of banks and copses, as a consequence of changing farming practice. Insecticides have also been implicated as a cause of this decline; in particular the use of dieldrin in the 1960's (Mellanby, 1967). However the use of this insecticide is now restricted, and its occasional use is probably not a threat to badgers. The main threat of poisoning now is likely to come from organo-mercury seed dressing, which badgers may consume from farm outbuildings. It is unlikely that chronic poisoning will result from these seed dressings, since they are not available frequently, and the half life of methyl mercury, in the mammalian body, is 25 days (P.R.Evans, pers. comm.).

The distribution may be influenced by the habitat in certain areas. It is unlikely that farming practice would reduce the productivity of badger foods to such a level as to influence badger numbers, since the calculations on page 96 assumed a figure of 50 grams of earthworms per m^2 ; this figure is the lower limit, given for arable land (Wallwork, 1970). In fact the practice of direct drilling, which involves drilling without cultivation, and is a growing practice on some East Anglian farms, may increase the number of earthworms and insects,

available to badgers. The main type of habitat where low productivity would restrict badger numbers is moorland; this might explain why badgers are infrequently found above 1,700 feet (southern, 1964). A comparison of sett dispersion in areas of differing productivity, using similar methods to the study on sparrowhawks by Newton, Marquiss, Weir and Moss (1977), may be a good method of demonstrating the importance of food as a factor affecting the density of badger populations. It is possible that as a consequence of social behaviour, there is a minimum density at which badgers can exist; an effect such as this would enhance both the East Anglian decline, and the effect of low productivity in areas such as moorland.

7

SUMMARY.

1. A population of the badger (Meles meles, L.) was studied during the summer months of 1975 in an area of five square kilometres, south of Durham City, and bounded by the River Wear, the A167, and the city itself.

2. A survey found three breeding setts, eight occupied setts, ten sporadically occupied setts and 49 unoccupied setts. The population was estimated as 22 adults, and eight cubs. These figures are similar to those found in previous surveys. In 1971 the estimated population was 31, cubs and adults, and in 1968 the population was 22 adults and seven cubs.

3. The physical factors affecting the utilisation of setts were studied. In comparison with unoccupied setts, the occupied setts tended to be near the upper breaks of slope, more convex in the horizontal plane. The preferred substrate was well drained sand, containing approximately seven per cent. clay plus silt. The occupied and breeding setts were usually found closer to the edge of the woodland than the unoccupied. All the breeding setts were found within 50 m. of water.

4. The spatial distribution of the breeding, occupied and visited was examined. The pattern consisted of clusters of main plus satellite setts, separated by 400 to 600 m.. It is suggested that these clusters represent single social units.

5. The diet over the summer months was examined by faecal analysis. It was found that:

- a. A wide variety of vegetable and animal food was taken.

- b. There were indications that fewer earthworms were taken in July and August, than in May and June; there was a corresponding increase in the mammals taken in the late summer.
 - c. It is suggested that the changes in food taken over the summer months are influenced by the state of the ground.
6. It is suggested that the home range would cover an area of approximately 50 hectares, on the assumption that it is circular.

8.

REFERENCES.

- Allen, R.H., and Cowlin, R.A.D., (1971). The badger in relation to geology in south-west Essex. Essex Naturalist 32, 307-312.
- Altman, P.L., and Dittmer, D.S., (eds.) (1968). Biological Handbook. Bethesda, Maryland: Fed. Amer. Soc. Exp. Biol.
- Anderse n, J., (1954). The food of the Danish badger (Meles meles danicus) with special reference to the summer months. Dan. Rev. Game Biol. 3, 1 - 75
- Bailey, N.J., (1959). Statistical methods in biology. London: English Universities Press.
- Bradbury, K., (1974). The diet of the badger. in: Middleton, A.C.V., and Paget, R.J., (eds.) (1974). Badgers of Yorkshire and Humberside. York: Sessions.
- Brody, S., (1945). Bioenergetics and growth (pp. 470 - 483). Baltimore, Ohio: Waverly Press.
- Clark, P.J., and Evans, F.C., (1954). Distance to nearest neighbour as a measure of spatial relationships in populations. Ecology 35, 445 - 453.
- Clark, P.J., (1956). Grouping in spatial distributions. Science 123, 373 - 374.
- Day, M.G., (1966). Identification of hair and feather remains in the gut and faeces of stoats and weasels. Proc. Zoo. Soc. Lond. 148, 201 - 217.
- Dunwell, M.R., and Killingley, A., (1969). The distribution of badger setts in relation to the geology of the Chilterns. J. Zool. Lond. 158, 204 - 208.

- Eisenberg, J.F., and Klieman, D.G., (1972).
Olfactory communication in mammals.
Ann. Rev. Ecol. Syst. 3, 1 - 32.
- Ewer, R.F., (1968). Ethology of mammals.
London: Elek Science.
- Ewer, R.F., (1973). The carnivores.
London: Weidenfeld & Nicolson.
- Fager, E., (1957). Determination and analysis of recurrent groups. Ecology 38, 586 - 595.
- Fitch, H.S., (1958). Home ranges, territories and seasonal movements of vertebrates on the natural history reservation.
Univ. Kansas Pub.: Mus. Nat. Hist. 11, 63 - 326.
- Golley, F.B., Petruszewicz, K., and Ryszkowski, L., (eds.) (1975).
Small mammals: their productivity and population dynamics.
Oxford: Blackwell. IBP Handbook No. 5.
- Grant, P.R. (1972). Interspecific competition in rodents.
Ann. Rev. Ecol. Syst. 3, 79 - 106.
- Iversen, J.A., (1972). Basal energy metabolism of Mustelids.
J. Comp. Physiol. 81, 341 - 344.
- Jeffries, D.J., (1965). Causes of badger mortality in the eastern counties of England.
J. Zool. Lond. 157, 429 - 436.
- Jewell, P.A., (1966). The concept of home range in mammals.
in: Jewell, P.A., and Loizos, C. (eds.) (1966).
Play, exploration and territory in mammals.
Symp. Zoo. Soc. Lond. 18, 85 - 109.

- Jones, H.Bowen, (1970). An atlas of Durham City.
Univ. Durham: Dept. Geography: Occasional Papers
Series 4. 3rd ed.
- King, J.A., (1955). Social behaviour, social organisation
and population dynamics in a black-tailed prairie-
dog town in the Black Hills of South Dakota.
Contrib. Lab. Vert. Biol., Univ. Michigan, Ann
Arbor, 67.
- Krebs, J.R., (1971). Territory and breeding density in
the great tit, Parus major L.
Ecology 52, 2 - 22.
- Lafague, M.Bonnin, and Canivenc, R., (1961). Etude de
l'activite du blaireau europeen.
Mammalia 25, 476 - 484.
- Likhachev, G.N., (1956). Some ecological traits of the
badger in Tula albatis broad-leaf forests.
in: Yorgensen, P.B. (ed.). Studies in Government
Preserves. Published and translated by the Isreal
Program for Scientific Translations: National
Science Foundation, Washington, D.C.
- McDonald, D.W., (1976). Nocturnal observations of tawny
owls Strix aluco preying on earthworms.
Ibis 118, 579 - 580.
- McDougall, P., (1976). The feral goats of Kielderhead Moor.
J. Zool. Lond. 176, 215 - 246.
- McNab, B.K., (1963). Bioenergetics and determination of
home range size. Amer. Nat. 97, 133 - 140.

- Martin, W. Keble, (1969). The concise British flora in colour. 2nd ed.
London: Ebury Press and Michael Joseph.
- Mellanby, K., (1967). Pesticides and pollution.
London: Collins. Fontana New Naturalist Series.
- Middleton, A. L. V., and Paget, R. J., (1974).
Badgers of Yorkshire and Humberside.
York: Sessions.
- Mohr, C. B., (1947). Table of equivalents of North American small mammals. Amer. Midl. Nat. 37, 223 - 249.
- Neal, E. G., (1948). The badger.
London: Collins. New Naturalist Series.
- Neal, E. G., (1965). Britain and beasts of prey.
Oryx 8, 83 - 88.
- Newton, I. Marquiss, M. Weir, D. N. and Moss, D., (1977).
Spacing in sparrowhawk nesting territories.
J. Appl. Ecol. 46, 425 - 443.
- Notini, G., (1948) Investigations on the biology of the Swedish badger.
Upsala: Almqvist & Wiksell. (summary in English).
- Paterson, I. J., (1965). Timing and spacing of broods in the black-headed gull Larus ridibundus.
Ibis 107, 433 - 459.
- Petrusewicz, K., and McFadyen, A., (1970). Productivity in terrestrial animals: principles and methods.
Oxford: Blackwell. IBP Handbook No. 13.
- Rackham, O., (1976). Trees and woodland in the British landscape.
London: Dent.

- Sargeant, A.B., and Warner, D.W., (1972). Movements and denning habits of a badger (taxidea taxus).
J. Mammal. 53, 207 - 210.
- Satchell, J.E., (1971). Earthworms.
in: Philipson, J., (ed.). Methods of study in quantitative soil ecology (population, production and energy flow).
Oxford: Blackwell. IBP Handbook No. 18.
- Schoener, T.W., (1968). Size and feeding areas in birds.
Ecology 49, 123 - 141
- Siegel, S., (1956). Non-parametric statistics for the behavioral sciences.
New York, London: McGraw-Hill.
- Soper, E.A., (1955). When badgers wake.
London: Routledge, Kegan and Paul.
- Southern, H.N., (1964) Handbook of British Mammals.
Oxford: Blackwell.
- Southwood, T.R.E., (1966). Ecological methods.
London: Chapman and Hall.
- Stewart, D.M., (1967). Analysis of plant remains in faeces: a technique for studying food preferences in grazing herbivores. J. Appl. Ecol. 4, 83 - 111.
- Stirling, A.E., and Harper, R.J., (1969). The distribution and habits of badgers on the southern outskirts of Durham City. Bull. Mammal Soc. Br. Isl. 32, 5 - 6.
- Studier, E.H., and Procter, J.W., (1971). Respiratory gases in burrows of Spermophilus sp.
J. Mammal. 52, 631 - 633.

- Thompson, H.R., (1956). The distribution of distance to the n^{th} nearest neighbor on a population of randomly distributed individuals.
Ecology 37, 391 - 394.
- Verts, B.J., (1967). The biology of the striped skunk.
Chicago: University of Illinois Press.
- Vogel, S., (1972). Interfacial organisms: passive ventilation in velocity gradients near surfaces.
Science 175, 210 - 211.
- Voth, E.H., and Black, H.C., (1973). A histological technique for determining feeding habits of small herbivores.
J. Wildl. Manag. 37, 223 - 231.
- Wallwork, J.A., (1970). Ecology of soil animals.
London: McGraw-Hill.
- Watson, A., and Moss, R., (1969). Population limitation in vertebrates.
in: Watson, A., (ed.). Animal populations in relation to their food resources.
Symp. Brit. Ecol. Soc. No. 10, 167 - 218.
- Wiegert, R.G., (1963). Energy dynamics of the grasshopper populations in old field and alfalfa field ecosystems.
Oikos 16, 161 - 176.

9.

ACKNOWLEDGMENTS.

My thanks are due to Dr K.R.Ashby for his help in completing this dissertation, to Dr P.R.Evans for his helpful comments on the dissertation, and to Dr I. Evans for his advice on the more statistical content.

I also wish to thank the following: J.Richardson; the staff of the Durham University computer centre, especially J.Steele; S.Hall; and S.Burgess, who typed the bulk of the revised draught.

Finally I must thank the University of Durham, department of zoology for providing the facilities for this dissertation.

APPENDIX 1.

METHODS USED IN THE 1968 AND 1971 SURVEYS

1. The 1968 Survey.

This survey used methods similar to those of the present survey. The activity was checked initially by placing crossed sticks in the entrance hole; further to this the mound outside the entrance hole was raked, and inspected for footprints. Terrain permitting, most of the setts found active on these criteria were watched. Additional information was also collected from regular badger watchers. Less attention was paid to inactive setts than in the present study. When the author examined maps supplied by Miss Harper, a larger number of inactive setts were found than quoted in the published results (Stirling and Harper, 1969). The final population estimate was obtained by a similar method to that used in the present study. The results, with the exception of the number of extinct setts may be meaningfully compared with those of the present study.

2. The 1971 Survey.

This survey relied heavily on the use of the "crossed sticks" method, to determine the activity of the setts. Although there was some observation of the setts, it is doubtful whether all the sett reported to be occupied by badgers; in fact in some of the places where setts were marked fox earths or rabbit warrens were found. Hence it is possible that some of the setts recorded were not in fact used by badgers. The population estimate used was the number of holes, where crossed sticks had been disturbed, divided by two. This estimate is a "rule of thumb", and its

methodological basis is open to doubt; no investigations have been carried out in order to determine the reliability of this estimate. However can be seen from table 3.1b (p.15), a population estimate calculated on the above basis, for the date from the present survey, does give a similar figure to that obtained in 1971. Hence it may be possible that the population and the number of setts found active in the 1971 survey is an over-estimate.

APPENDIX 2.

The raw data used in the analysis of physical factors affecting dispersion, See over

SETT	STATUS	D_WATER	D_PATH	D_DWELL	D_EDGE	D_UPPER	D_LOWER	H_CONV
H1	UNOCC	231	19	109	115	13	54	0
H2	UNOCC	173	38	54	128	38	109	-1
H3	UNOCC	170	42	64	122	42	96	-1
H4	UNOCC	167	38	77	128	38	96	-1
H5	VISIT	80	10	45	96	6	122	-2
H6	BREED	58	13	186	74	38	96	-1
H7	UNOCC	64	19	321	83	13	96	1
H8	UNOCC	77	19	256	83	19	26	0
H9	UNOCC	74	6	237	45	35	6	0
H10	UNOCC	74	22	250	99	22	26	0
GH1	UNOCC	250	3	109	6	7	2	-2
GH2	UNOCC	237	6	115	6	3	5	-2
GH3	VISIT	128	205	193	80	16	35	1
GH7	OCC	203	10	128	19	2	1	1
GH16	UNOCC	83	32	160	32	83	45	1
GH17	UNOCC	192	22	32	51	19	109	1
PH1	VISIT	128	205	192	32	10	3	2
PH2	OCC	96	45	295	19	15	7	1
SG1	BREED	13	130	610	16	3	8	2
SG2	OCC	10	143	584	32	16	6	0
SG3	UNOCC	20	136	714	13	8	18	-1
RB7	UNOCC	5	26	974	195	2	4	1
RB8	OCC	266	156	558	5	7	2	1
RB10	VISIT	5	14	519	195	1	8	0

SETT	STATUS	D_WATER	D_PATH	D_DWELL	D_EDGE	D_UPPER	D_LOWER	H_CONV
MC1	UNOCC	282	3	38	54	3	45	-1
MC2	UNOCC	282	6	13	51	4	51	-1
MC4	UNOCC	288	16	87	16	38	19	-1
MC6	OCC	179	35	144	35	19	38	1
MC7	UNOCC	93	38	292	32	32	38	1
MC8	OCC	45	19	356	64	13	32	2
MC9	OCC	83	26	349	38	16	32	0
MC10	UNOCC	205	26	266	45	13	38	-1

SETT	V_CONV	COVER	INCLIN	%_WATER	E_DIG	%_CLAY	HABIT
H1	0	4	28	8	22	10	R_BL
H2	1	4	29	22	9	13	R_BL
H3	1	3	25	17	8	11	R_BL
H4	1	4	28	11	10	10	R_BL
H5	0	4	25	11	10	10	R_BL
H6	1	4	22	5	7	8	R_BL
H7	1	4	19	7	7	10	R_BL
H8	1	4	25	16	9	4	R_BL
H9	1	4	34	6	8	9	R_BL
H10	1	3	25	19	7	7	R_BL
GH1	0	2	28	10	9	15	R_BL
GH2	0	2	22	9	14	12	R_BL
GH3	0	3	33	4	10	10	R_BL
GH7	0	3	21	9	11	7	R_BL
GH16	2	2	36	8	22	7	R_BL
GH17	1	2	29	12	11	3	R_BL
PH1	1	3	34	9	14	6	R_BL
PH2	1	1	27	8	10	-	AG_L
SG1	1	1	23	9	6	7	AG_L
SG2	1	3	35	4	4	8	AG_L
SG3	2	4	26	17	4	11	R_BL
RB7	1	2	24	19	24	13	R_BA
RB8	0	1	29	3	5	8	AG_L
RB10	1	1	26	6	3	7	R_BA

SETT	V_CONV	COVER	INCLIN	%_WATER	E_DIG	%_CLAY	HABIT'
MC1	-1	3	25	-	-	-	M_C
MC3	-1	3	25	-	-	-	M_C
MC4	0	2	22	-	15	-	M_C
MC6	0	3	22	-	14	-	M_C
MC7	-1	2	19	-	13	-	M_C
MC8	1	4	33	-	8	-	M_C
MC9	0	2	24	-	10	-	M_C
MC10	0	1	27	-	12	-	M_C

APPENDIX 3.

The tables over and the maps following show the positions and the status of all the setts found in all the surveys (1968, 1971 and 1975). The sett status is abbreviated, in the tables, as follows:

UNOCC = Unoccupied.

VISIT = Visited.

OCC = Occupied.

BREED = Breeding.

FOX = Sett Occupied by Fox, or Fox Earth.

RABB = Sett Occupied by Rabbits, or Rabbit Warren.

In the 1971 survey no distinction was made between occupied and breeding setts (see appendix 1, 2). The grid reference for each sett is the eight figure grid reference, in kilometres, for the national grid square NZ. The grid references are those used in computing the nearest neighbour distances.

The maps shown are on the same scale (1:6,500) as those used for the survey. The maps were enlarged from a six inch series (1:10,560) Ordnance Survey map; the quoted accuracy is plus or minus six metres. The maps have been amended to show the present position of field boundaries, and to indicate the approximate positions of the colleges, built since the original survey.

<u>SETT NUMBER</u>		<u>STATUS</u>			<u>GRID REFERENCE</u>	
1975 AND 1971	1968	1968	1971	1975	EAST-WEST	SOUTH-NORTH
MC1		UNOCC	UNOCC	UNOCC	28.11	41.94
MC2		UNOCC	UNOCC	-	28.11	41.91
MC3		UNOCC	UNOCC	UNOCC	28.11	41.98
MC4		UNOCC	UNOCC	UNOCC	28.15	41.87
MC5		UNOCC	UNOCC	RABB	28.16	41.83
MC6	15	OCC	OCC	OCC	28.20	41.80
MC7	14	UNOCC	UNOCC	UNOCC	28.34	41.75
MC8		UNOCC	OCC	OCC	28.40	41.68
MC9		UNOCC	OCC	OCC ⁺	28.36	41.64
MC10		UNOCC	VISIT	UNOCC	28.23	41.63
MC11		UNOCC	UNOCC	-	28.13	41.62
GH1	8	FOX	UNOCC	UNOCC	27.57	40.00
GH2	9	FOX	UNOCC	FOX	27.58	40.00
GH3		-	UNOCC	VISIT	27.61	40.83
GH4		-	UNOCC	UNOCC	28.65	40.78
GH5		UNOCC	UNOCC	-	27.67	40.91
GH6		-	UNOCC	UNOCC	27.70	40.77
GH7		-	OCC	OCC	27.79	40.74
GH8		-	UNOCC	UNOCC	27.82	40.75
GH9		-	UNOCC	RABB	27.84	40.75
GH10		-	UNOCC	UNOCC	27.93	40.84
GH11		-	UNOCC	UNOCC	27.94	40.82
GH12	10	VISIT	UNOCC	UNOCC	27.95	40.86
GH13	11	VISIT	UNOCC	UNOCC	28.02	40.92
GH14		-	UNOCC	UNOCC	28.02	40.84
GH15		-	OCC	VISIT	28.03	40.83

⁺ This sett was dug during the study, but was occupied until mid May.

<u>SETT NUMBER</u>			<u>STATUS</u>			<u>GRID REFERENCE</u>	
1975 AND 1971	1968	1968	1971	1975	EAST-WEST	SOUTH-NORTH	
			UNOCC	VISIT	UNOCC	28.07	41.00
			-	UNOCC	UNOCC	27.99	41.05
			UNOCC	UNOCC	UNOCC	28.09	41.07
			UNOCC	OCC	UNOCC	27.97	41.36
	25	VISIT	-	-	27.08	40.25	
	13	VISIT	-	-	27.87	40.93	
		UNOCC	-	-	27.75	40.82	
			-	UNOCC	UNOCC	27.58	40.78
			-	UNOCC	UNOCC	27.52	40.70
			-	UNOCC	FOX	27.51	40.67
			-	UNOCC	UNOCC	27.50	40.65
			-	UNOCC	VISIT	27.45	40.62
	5	OCC	OCC	BREED	27.44	40.54	
	23	UNOCC	UNOCC	UNOCC	27.46	40.68	
	7	UNOCC	UNOCC	UNOCC	27.50	40.29	
			-	UNOCC	UNOCC	27.52	40.29
			-	UNOCC	UNOCC	27.45	40.42
			-	-	UNOCC	27.51	40.40
			-	-	UNOCC	27.53	40.44
	6	VISIT	UNOCC	FOX	27.42	40.63	
	27	VISIT	UNOCC	VISIT	27.54	40.15	
	28	OCC	OCC	OCC	27.70	40.13	

<u>SETT NUMBER</u>			<u>STATUS</u>			<u>GRID REFERENCE</u>	
1975 AND 1971	1968	1968	1971	1975	EAST-WEST	SOUTH-NORTH	
BW1		-	UNOCC	UNOCC	27.16	40.16	
BW2		-	VISIT	VISIT	27.03	40.11	
BW3	3b	BREED	-	VISIT	26.77	40.38	
BW4	3a	VISIT	-	-	27.08	40.17	
BW5	3c	UNOCC	-	-	27.10	40.20	
WW1		-	UNOCC	UNOCC	28.21	40.66	
WW2	24	FOX	VISIT	VISIT	28.25	40.68	
WW3		-	UNOCC	UNOCC	27.70	40.33	
WW4		-	OCC	UNOCC	27.69	40.32	
WW5		-	UNOCC	-	27.63	40.31	
WW6		-	UNOCC	-	27.61	40.28	
WW7		-	OCC	RABB	27.60	40.28	
WW8	4	FOX	UNOCC	RABB	27.47	40.18	
WW9		-	-	RABB	27.46	40.19	
SG1	18	OCC	OCC	BREED	27.25	39.92	
SG2		-	VISIT	OCC	27.27	39.94	
SG3	17	VISIT	UNOCC	UNOCC	27.50	39.64	
SG4	19	VISIT	-	-	27.46	39.64	
LB1		-	UNOCC	-	27.13	39.75	
LB2		-	UNOCC	UNOCC	26.94	39.74	
LB3		-	OCC	OCC	26.90	39.72	
LB4		-	-	VISIT	26.86	39.69	
LB5		-	-	UNOCC	26.91	39.75	

<u>SETT NUMBER</u>		<u>STATUS</u>			<u>GRID REFERENCE</u>	
1975 AND 1971	1968	1968	1971	1975	EAST-WEST	SOUTH-NORTH
RB1		-	UNOCC	UNOCC	27.07	38.72
RB2		-	UNOCC	UNOCC	26.99	38.84
RB3	20	UNOCC	UNOCC	UNOCC	26.87	39.29
RB4	21	VISIT	FOX	VISIT	26.90	39.56
RB5	22	VISIT	UNOCC	-	27.28	39.67
RB6		-	VISIT	-	27.80	39.36
RB7		-	UNOCC	UNOCC	28.17	39.14
RB8		-	VISIT	OCC	28.13	39.55
RB9		-	FOX	FOX	28.24	39.74
RB10	16	OCC	OCC	VISIT	28.43	39.87
DURHAM SCHOOL		BREED	OCC	BREED	-	-
VET'S HOUSE		BREED	OCC	UNOCC	-	-

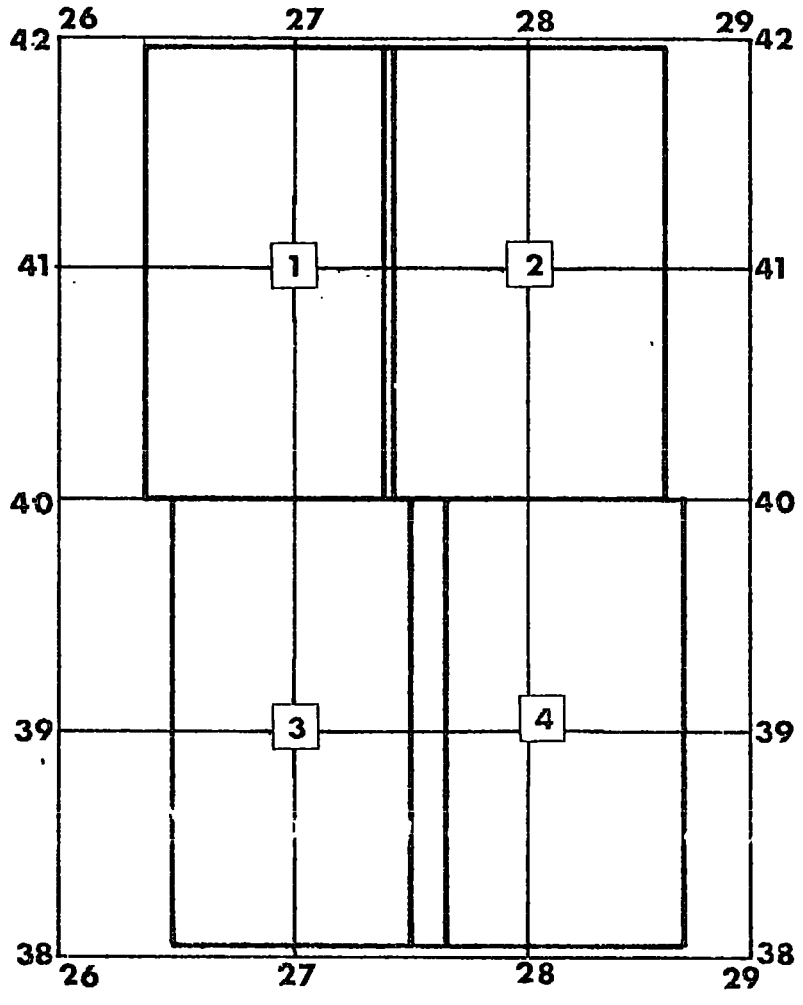

GRID SQUARE NZ

INDEX TO THE MAPS ON THE FOLLOWING PAGES.

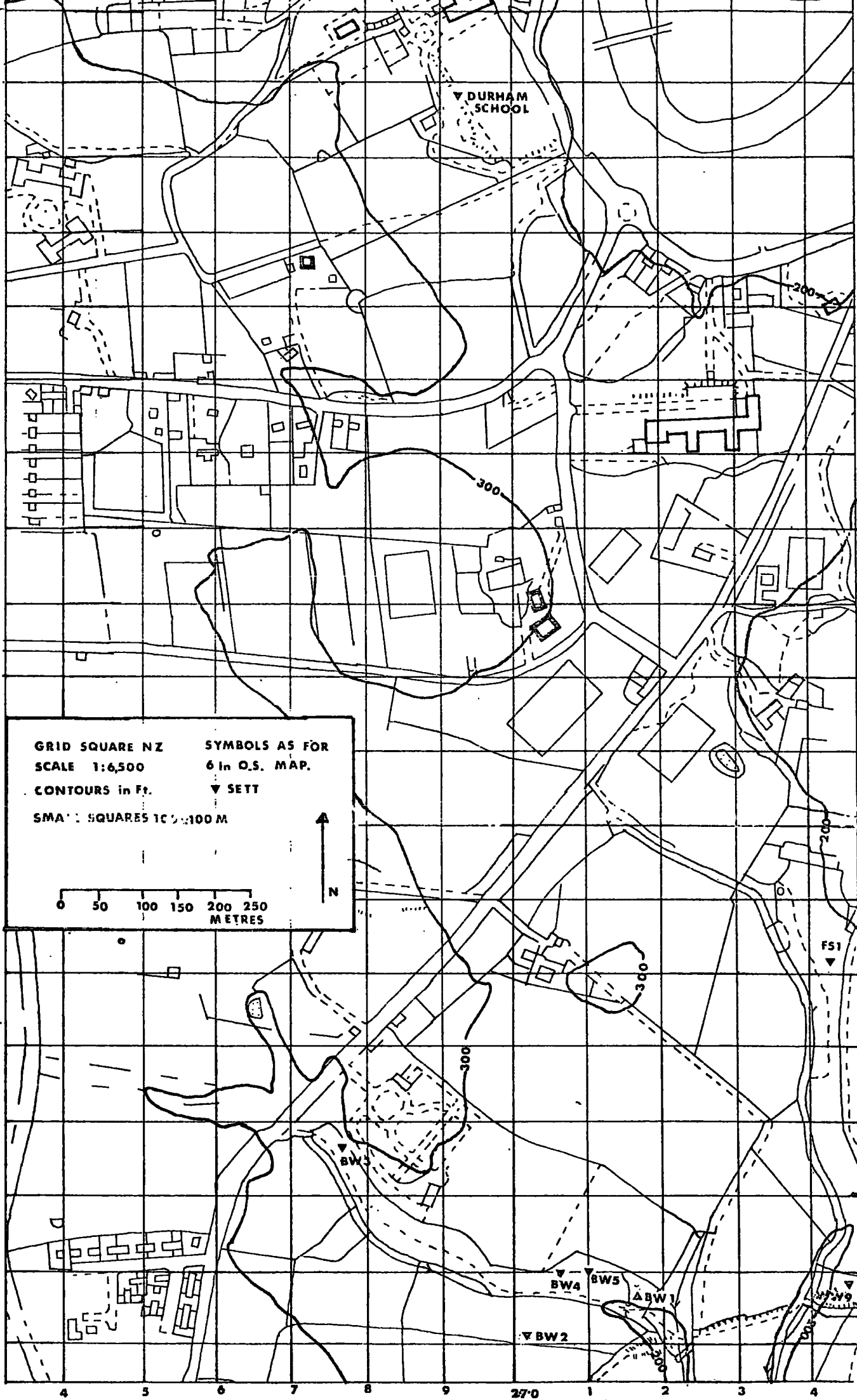

GRID SQUARE NZ SYMBOLS AS FOR
SCALE 1:6,500 6 in O.S. MAP.
CONTOURS in Ft. ▼ SETT
SMA SQUARES 100x100 M

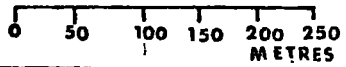

4 5 6 7 8 9 27-0 1 2 3 4

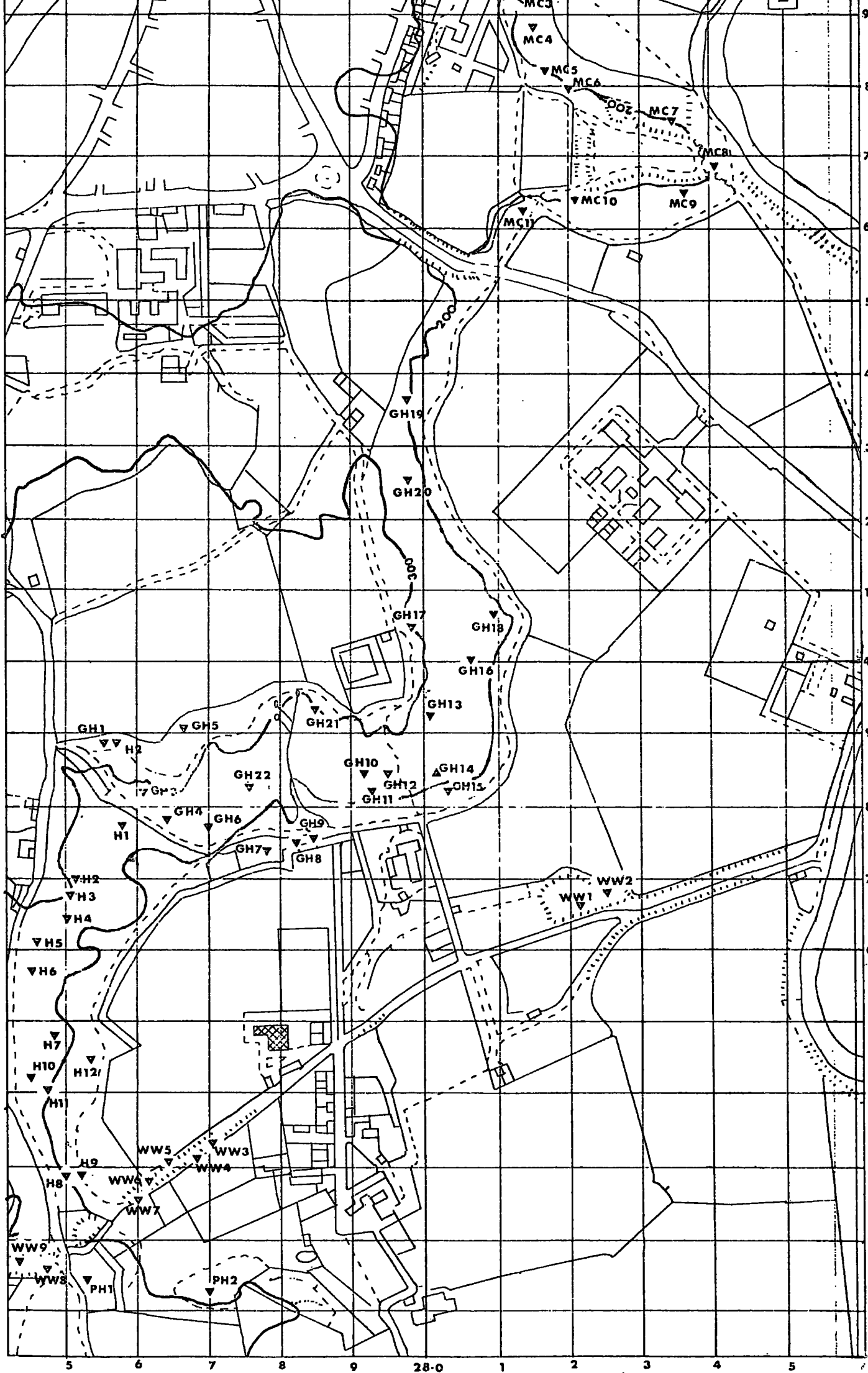

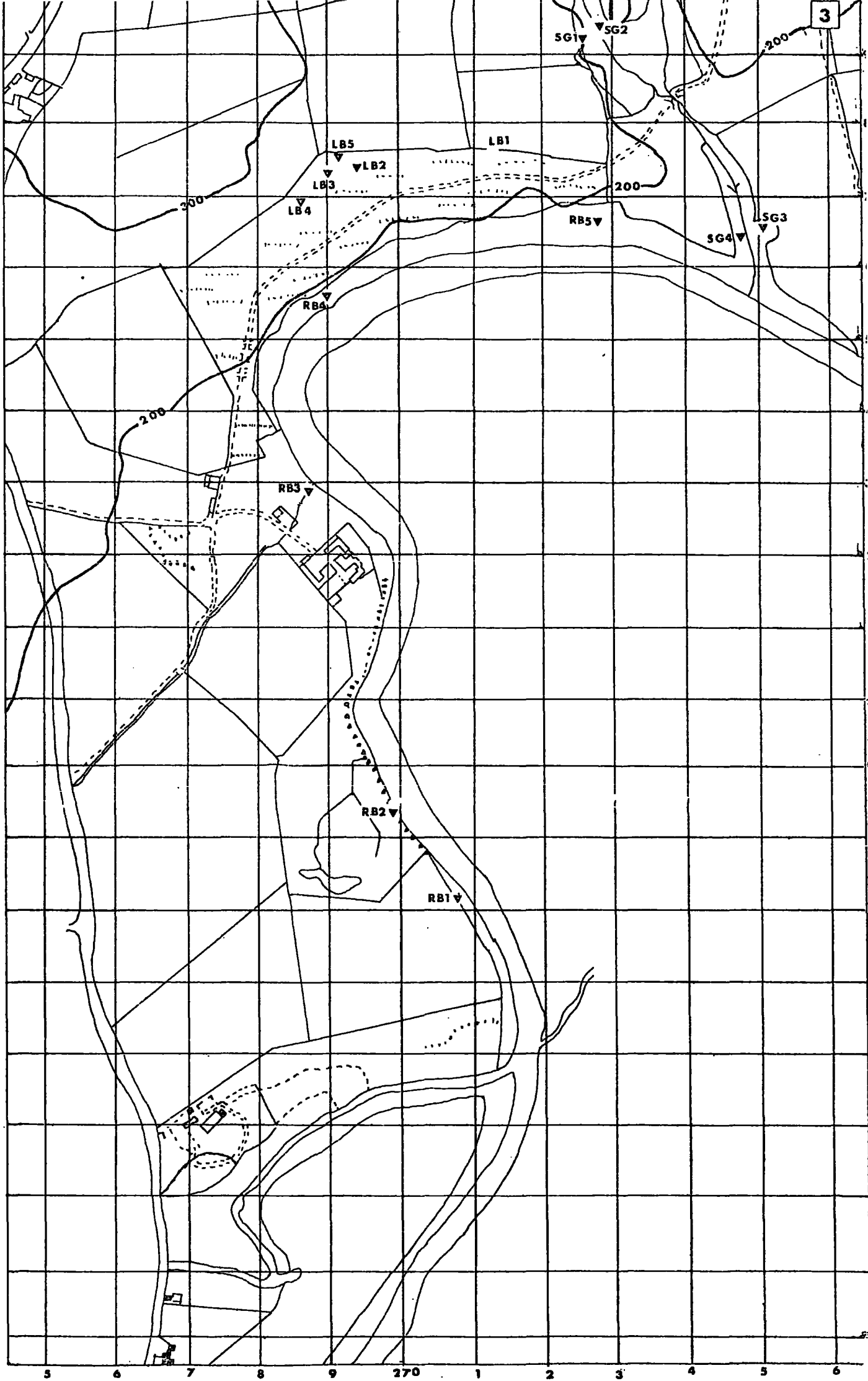

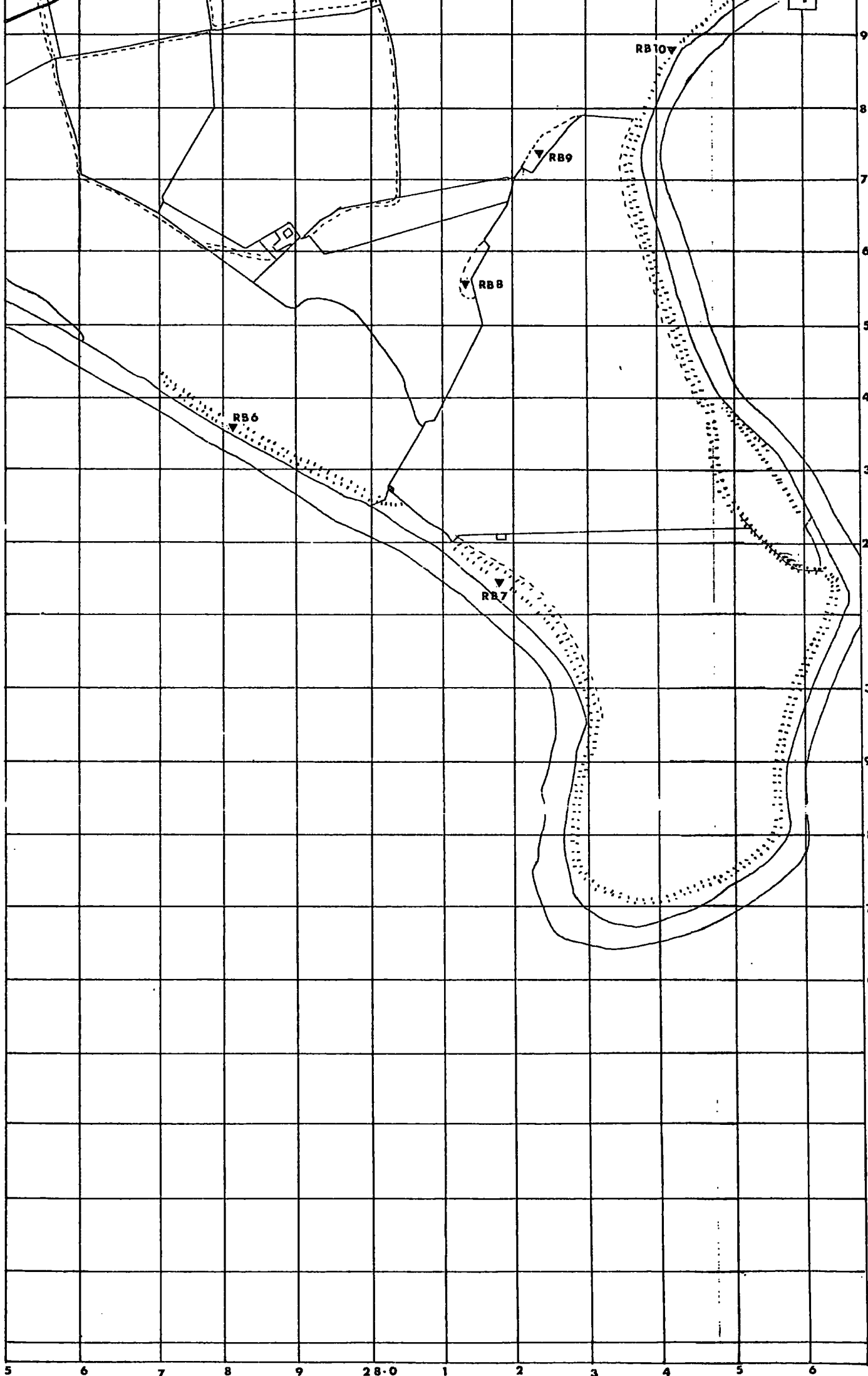

APPENDIX 4.

The appendix shows the key prepared for the identification of fragments of epidermis found in the faeces; the key was prepared from the photomicrographs taken for the study, which are also shown in the appendix. The only species, found in the badger's faeces, which is not illustrated is Rumex; this was amongst the photomicrographs supplied by Dr Ashby (see p.76). The key is intended as an aid to identification. A more precise identification can be achieved by comparison to the photomicrographs, which follow. The final three plates show a whole mount (plate A.4.11A), a cross section (plate A.4.11B), and a gelatine cast (plate A.4.12) of badger hair. These photomicrographs have been taken of material, prepared according to the methods on page



A. Allium.

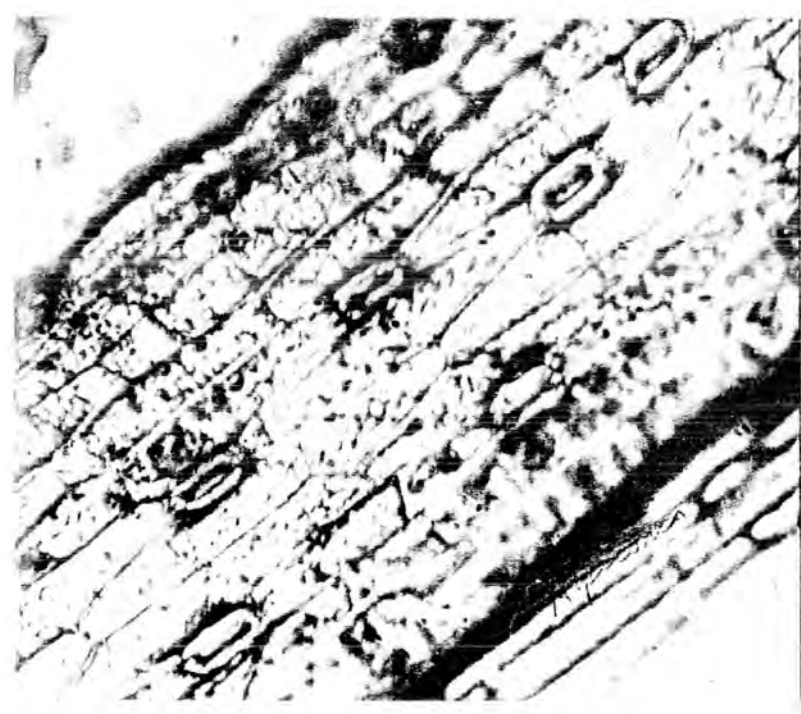

B. Alopecurus.

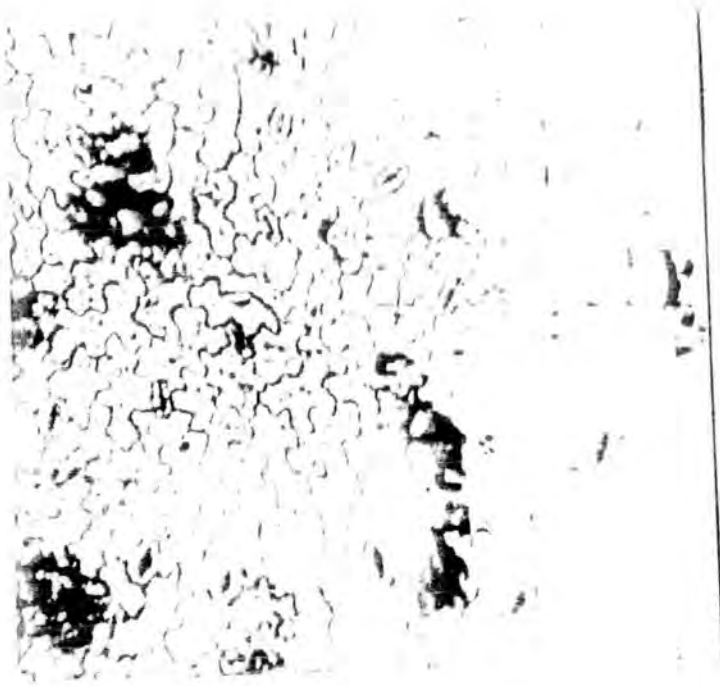

A. Cirsium.



B. Dactylis.

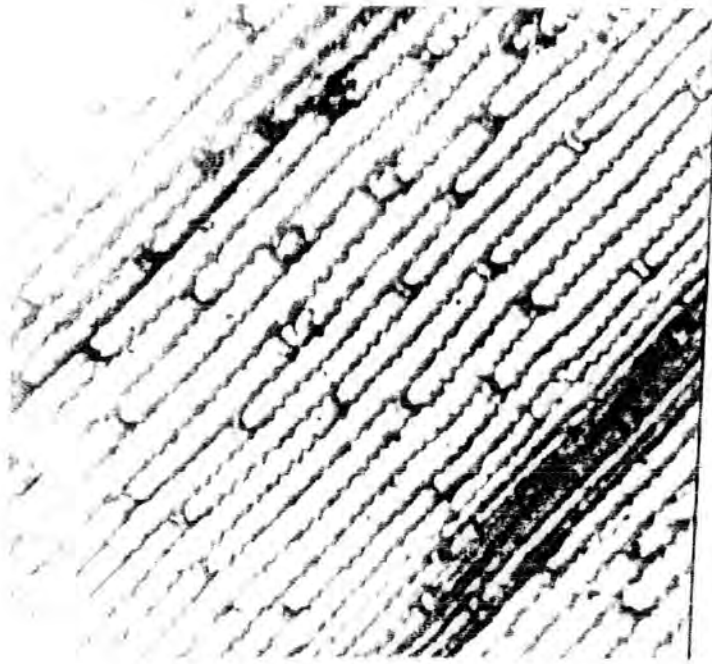

A. Deschampsia.

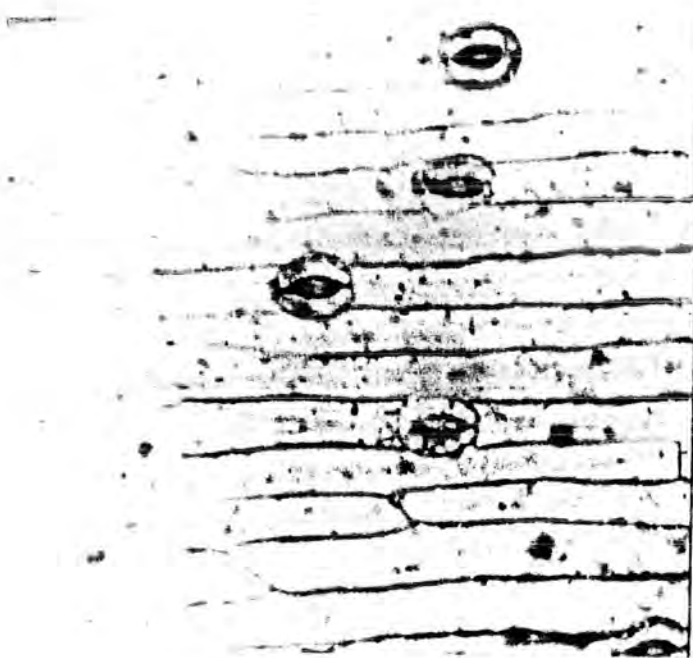

B. Endymion.

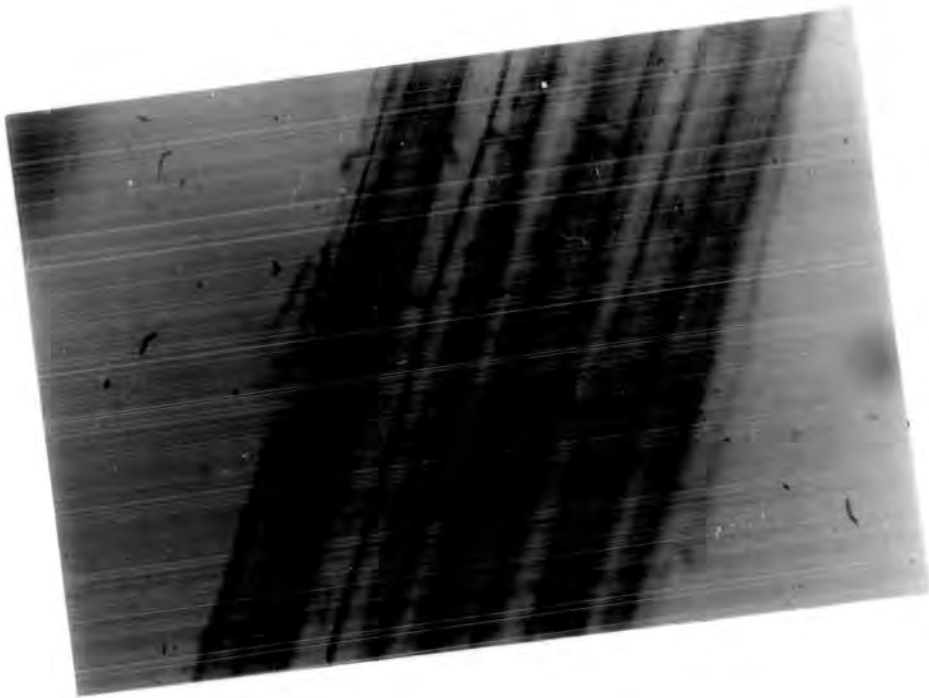

A. Festuca.

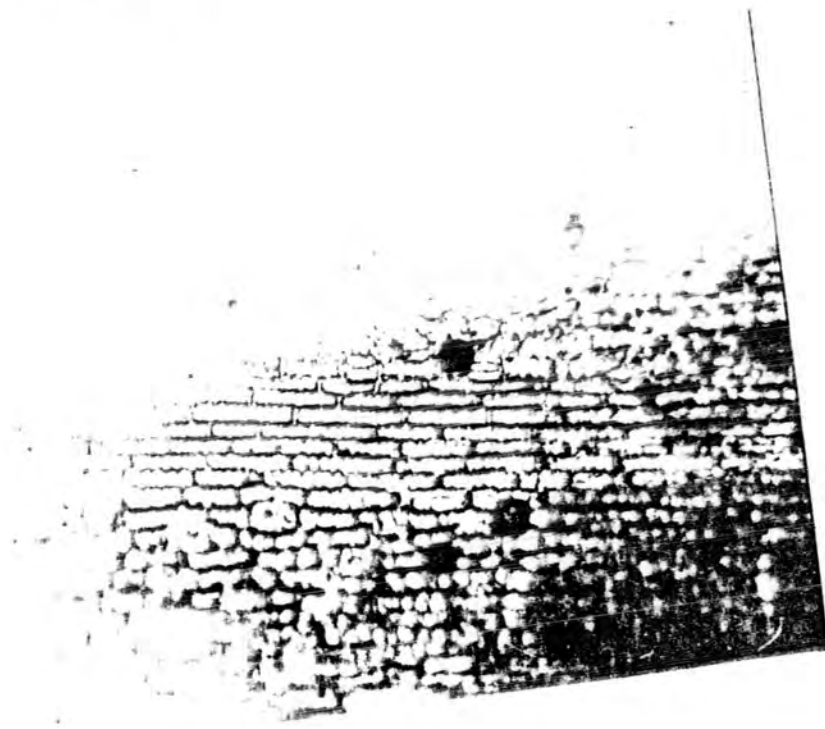

B. Juncus.

PLATE A. 4.4.

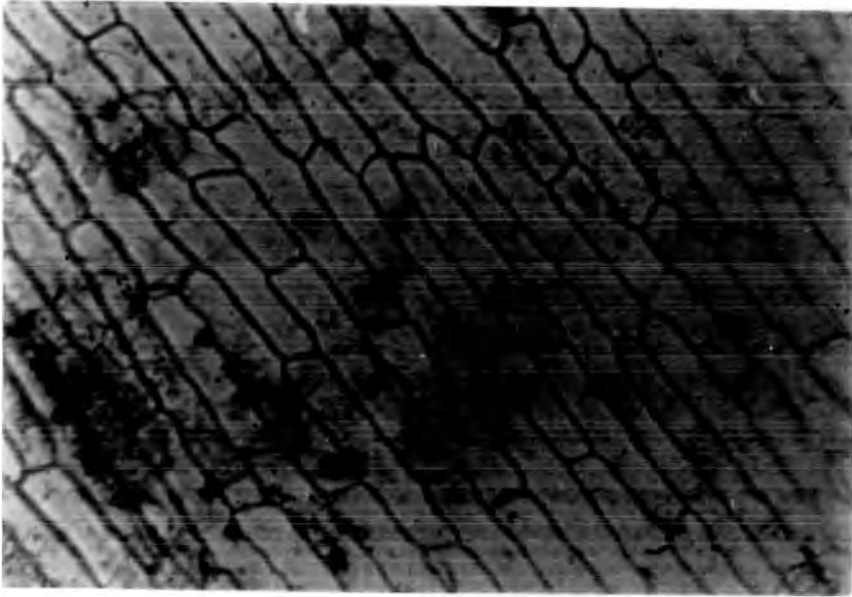

A. Luzula.

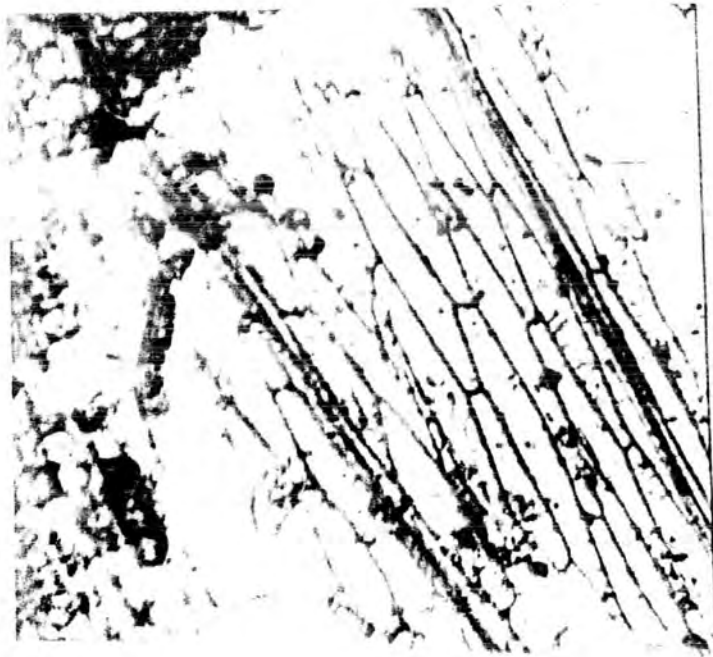

B. Poa.

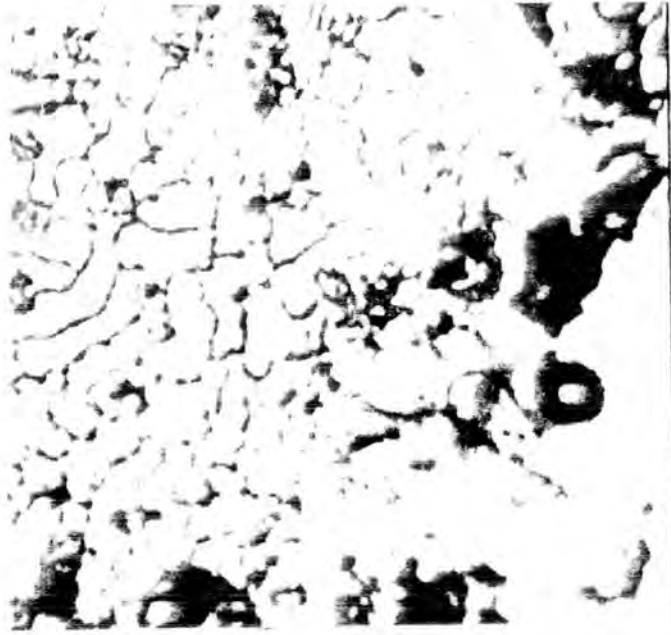

A. Plantago lanceolata. (epidermis)

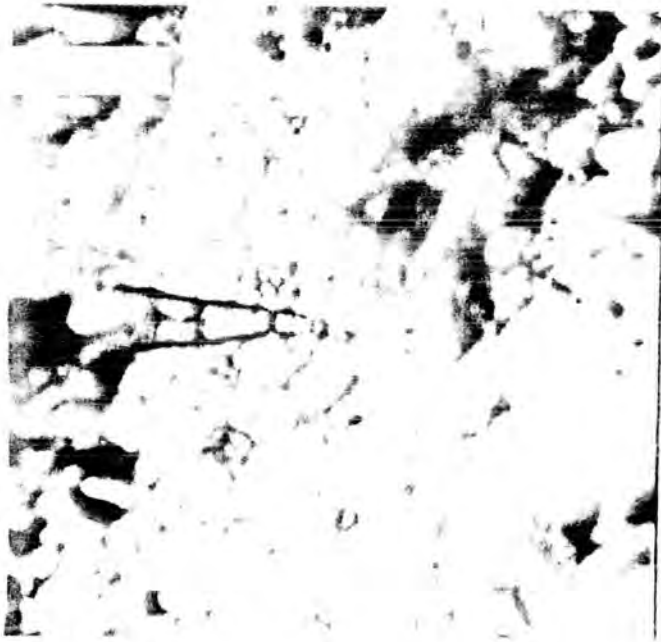

B. Plantago lanceolata (hair)

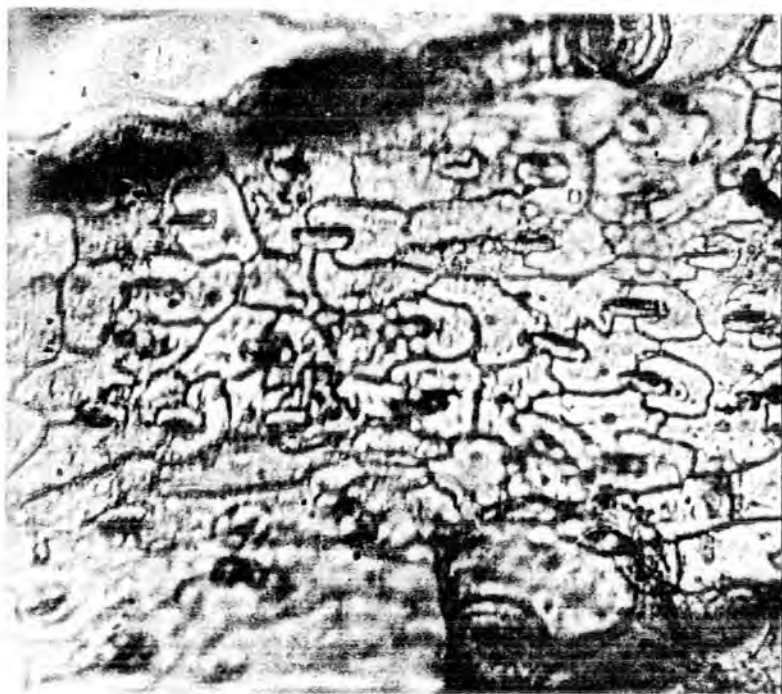

A. Plantago major. (epidermis)

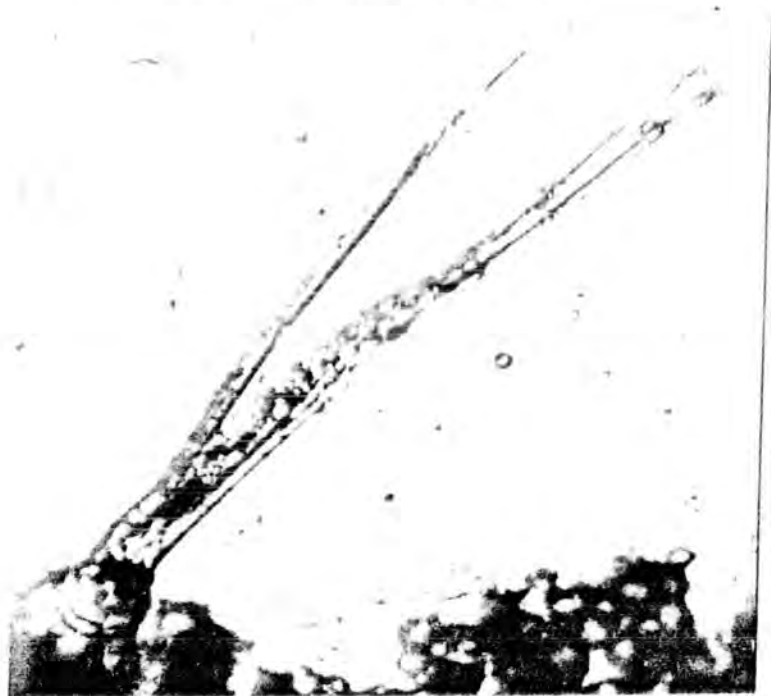

B. Plantago major. (hair)

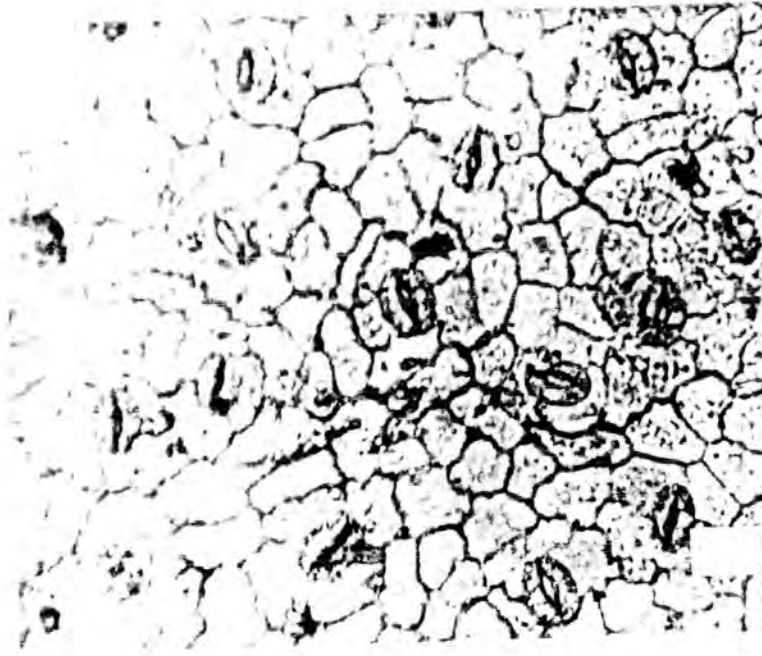

A. Polygonum.

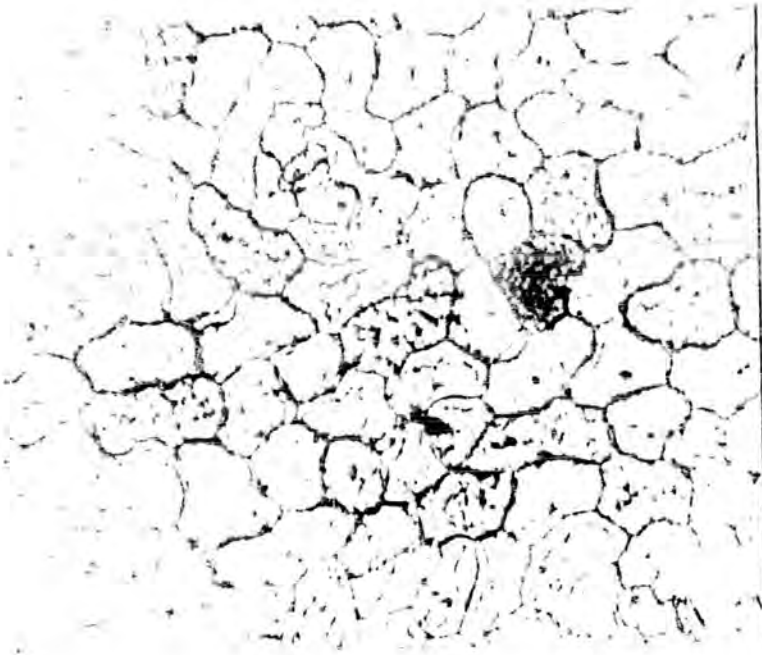

B. Rumex.

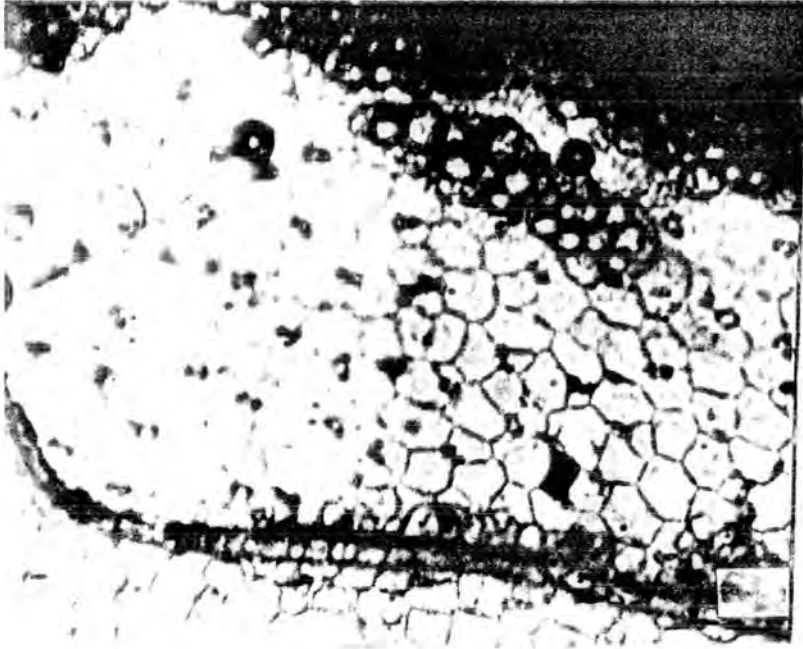

A. Stellaria.



B. Taraxacum.

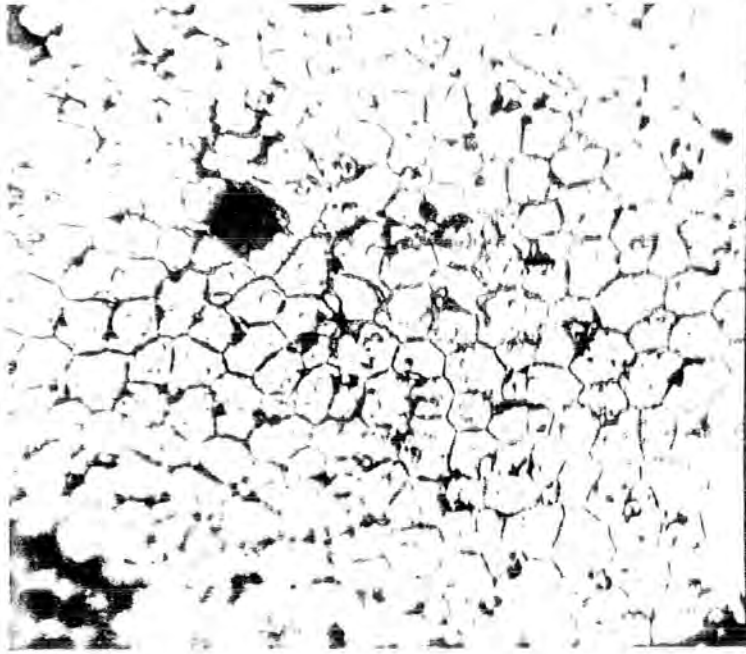

A. Trifolium.

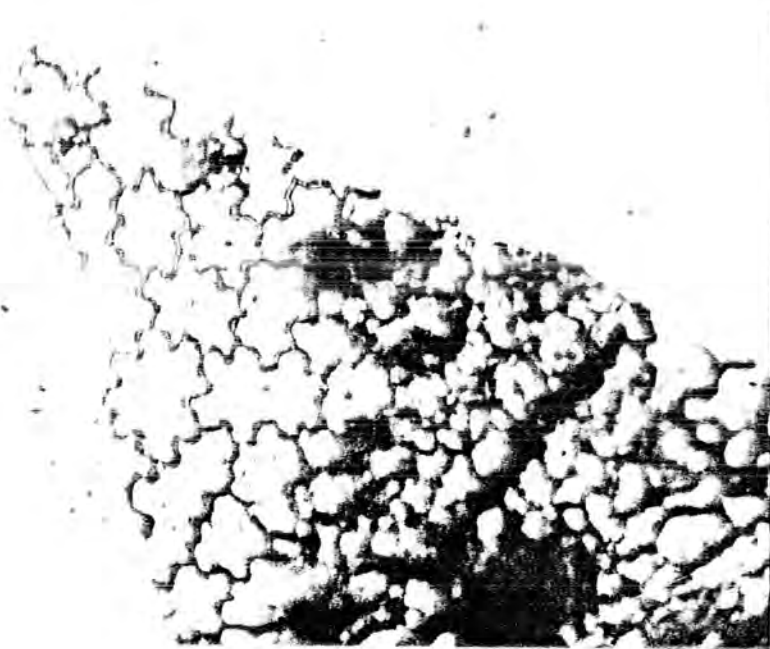

B. Veronica.

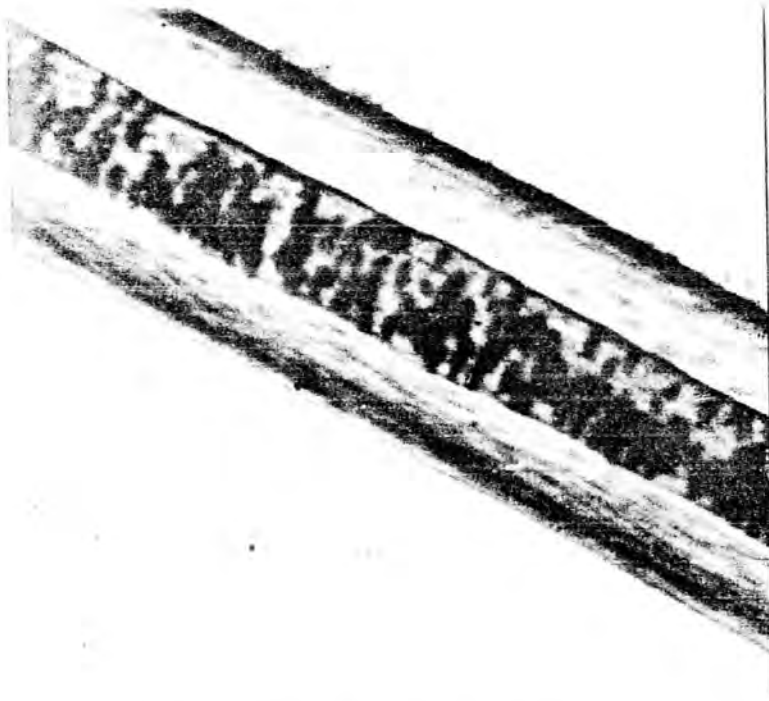

A. Badger hair (whole mount).



B. Badger hair (cross section).

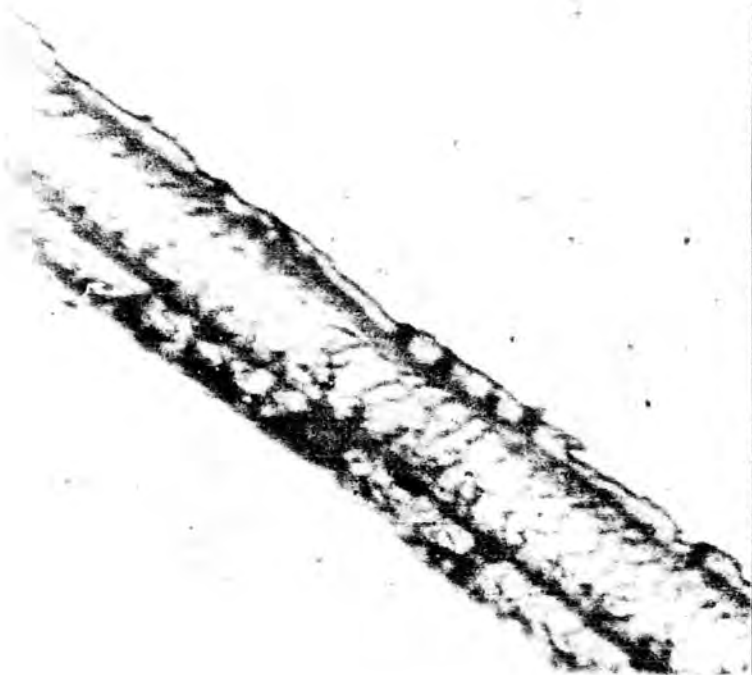

Badger hair (gelatine cast).

PLATE A.4.12.

APPENDIX 5.

Table A.6.1 shows the dates of collection, the serial number and the condition of the scats collected. Collection from RB8 did not begin until 18:5:1975; the dates on which no scats were found are indicated by an asterisk. The division between fresh and old is based on the state of hydration of the scats, which is influenced by the preceeding weather. Hence the division is somewhat arbitrary. Table A.6.2 shows the presence or absence of a food item in the faeces. The serial numbers indicate the order of collection (see table A.6.1); where more than one scat was found an attempt was made to number them in the order in which they were deposited.

TABLE A.6.1.

THE DATES OF COLLECTION, THE SERIAL NUMBERS, AND THE CONDITION
OF THE SCATS COLLECTED.

<u>DATE</u>	<u>HOLLINGSIDE 6</u>		<u>RIVER BANK 8</u>	
	SERIAL NO.	CONDITION	SERIAL NO.	CONDITION
15:5:1975	1	OLD	-	
24:5:1975	2	FRESH	-	
29:5:1975	3	FRESH	-	
6:6:1975	4	OLD	-	
	5	FRESH		
12:6:1975	6	FRESH	-	
18:6:1975	7	FRESH	1	OLD
	8	FRESH		
	9	FRESH		
26:6:1975	10	FRESH	2	FRESH
	11	FRESH		
4:7:1975	12	FRESH	3	FRESH
10:7:1975	13	FRESH	*	
	14	FRESH		
18:7:1975	15	FRESH	4	OLD
24:7:1975	16	FRESH	5	FRESH
2:8:1975	17	FRESH	*	
8:8:1975	18	OLD	*	
16:8:1975	19	OLD	6	FRESH
	20	FRESH		
21:8:1975	21	FRESH	*	
30:8:1975	22	FRESH	7	FRESH

- Not Visited.

* No Scats Present.

TABLE A.6.2.

i. FOOD ITEMS PRESENT IN SCATS COLLECTED FROM HOLLINGSIDE WOOD 6,
SERIAL NUMBERS ONE TO ELEVEN.

SERIAL NO. OF SCAT:	1	2	3	4	5	6	7	8	9	10	11
<u>FOOD ITEM</u>											
<u>Sorex</u>	-	-	-	-	-	-	-	-	-	-	-
<u>Apodemus</u>	-	-	-	-	-	-	-	-	-	-	-
<u>Talpa</u>	-	-	-	-	+	-	-	-	-	-	-
<u>Arvicola</u>	-	-	-	-	-	-	-	-	-	-	-
<u>Oryctolagus</u>	-	-	-	-	-	-	-	-	-	-	-
Earthworm	+	+	+	+	-	-	-	+	+	-	+
Insect	-	-	-	+	+	-	-	+	-	-	-
<u>Endymion</u>	+	-	+	-	+	-	-	-	-	-	-
<u>Allium</u>	-	-	-	-	-	-	-	+	-	-	+
<u>Rumex</u>	-	-	+	-	-	-	-	+	-	+	+
<u>Plantago</u>	-	-	+	-	-	-	-	-	-	+	+
<u>Trifolium</u>	-	-	-	+	+	-	-	+	-	+	+
<u>Luzula</u>	-	-	-	+	-	+	+	-	+	-	-
<u>Juncus</u>	+	-	-	-	-	-	-	-	-	-	-
<u>Festuca</u>	+	+	-	-	+	+	+	+	+	-	+
<u>Deschampsia</u>	-	+	-	-	-	-	-	-	-	-	+
<u>Bromus</u>	-	-	-	+	+	+	+	-	-	-	-
<u>Poa</u>	-	-	-	-	-	-	-	-	-	-	-
Berries	-	-	-	-	-	-	-	-	+	-	-
Root (conifer)	-	-	-	-	-	+	-	-	-	-	-
Cereal	-	-	-	-	-	-	-	-	-	-	+
	1	2	3	4	5	6	7	8	9	10	11

+ Indicates Presence.

- Indicates Absence.

TABLE A.6.2.

ii. FOOD ITEMS PRESENT IN SCATS COLLECTED FROM HOLLINGSIDE WOOD 6,
SERIAL NUMBERS TWELVE TO TWENTY TWO.

SERIAL NO. OF SCAT:	12	13	14	15	16	17	18	19	20	21	22
<u>FOOD ITEM</u>											
<u>Sorex</u>	-	-	-	-	-	+	-	+	-	-	-
<u>Apodemus</u>	-	-	-	-	+	-	-	+	+	-	-
<u>Talpa</u>	-	-	-	-	-	-	-	-	-	-	+
<u>Arvicola</u>	-	-	-	-	-	-	-	-	-	-	-
<u>Oryctolagus</u>	-	-	-	-	-	-	+	-	-	+	-
Earthworm	-	+	-	-	-	+	-	+	+	-	-
Insect	+	-	-	-	-	+	-	-	+	-	-
<u>Endymion</u>	-	+	-	-	-	-	-	+	-	-	-
<u>Allium</u>	+	-	-	-	-	-	-	+	-	-	-
<u>Rumex</u>	-	+	+	-	-	+	-	-	+	+	-
<u>Plantago</u>	-	-	+	-	-	-	-	-	-	-	+
<u>Trifolium</u>	-	-	-	+	-	-	-	-	+	-	+
<u>Luzula</u>	-	-	-	+	-	-	-	+	-	+	-
<u>Juncus</u>	-	-	+	-	-	-	-	-	-	-	-
<u>Festuca</u>	+	-	+	-	-	-	-	-	-	-	+
<u>Deschampsia</u>	-	+	-	+	-	-	-	+	-	-	-
<u>Bromus</u>	+	-	-	-	-	+	-	-	-	+	+
<u>Poa</u>	-	-	-	+	-	-	-	-	-	-	-
Berries	-	+	-	-	-	-	-	-	-	-	-
Root (conifer)	-	-	-	+	-	-	-	-	-	-	-
Cereal	-	-	-	-	-	-	-	-	-	-	-
	12	13	14	15	16	17	18	19	20	21	22

+ Indicates Presence.

- Indicates Absence.

TABLE A.6.2.

iii. FOOD ITEMS PRESENT IN SCATS COLLECTED FROM RIVER BANK 8.

SERIAL NO. OF SCAT:	1	2	3	4	5	6	7
<u>FOOD ITEM</u>							
<u>Sorex</u>	-	-	-	-	-	-	-
<u>Apodemus</u>	-	-	-	-	-	-	-
<u>Talpa</u>	-	-	-	-	-	-	-
<u>Arvicola</u>	-	-	-	+	-	+	-
<u>Oryctolagus</u>	-	-	-	-	-	+	-
Earthworm	+	-	+	-	+	-	-
Insect	-	+	-	+	-	-	-
<u>Endymion</u>	-	-	-	+	-	-	-
<u>Allium</u>	-	-	-	+	-	-	-
<u>Rumex</u>	-	+	-	-	-	+	+
<u>Plantago</u>	+	-	-	-	+	+	-
<u>Trifolium</u>	+	+	-	-	-	-	-
<u>Luzula</u>	-	-	+	-	-	-	-
<u>Juncus</u>	-	-	+	-	-	+	-
<u>Festuca</u>	+	-	-	-	+	+	+
<u>Deschampsia</u>	-	-	+	-	-	-	-
<u>Bromus</u>	+	-	+	-	-	-	-
<u>Poa</u>	-	-	+	-	-	-	-
Berries	-	-	+	-	-	-	-
Root (conifer)	-	-	-	-	-	-	-
Cereal	+	-	+	-	+	-	-
	1	2	3	4	5	6	7

+ Indicates Presence.

- Indicates Absence.

The 1974 Mammal Society badger distribution map. Each point indicates a record in a 10 kilometre national grid square.

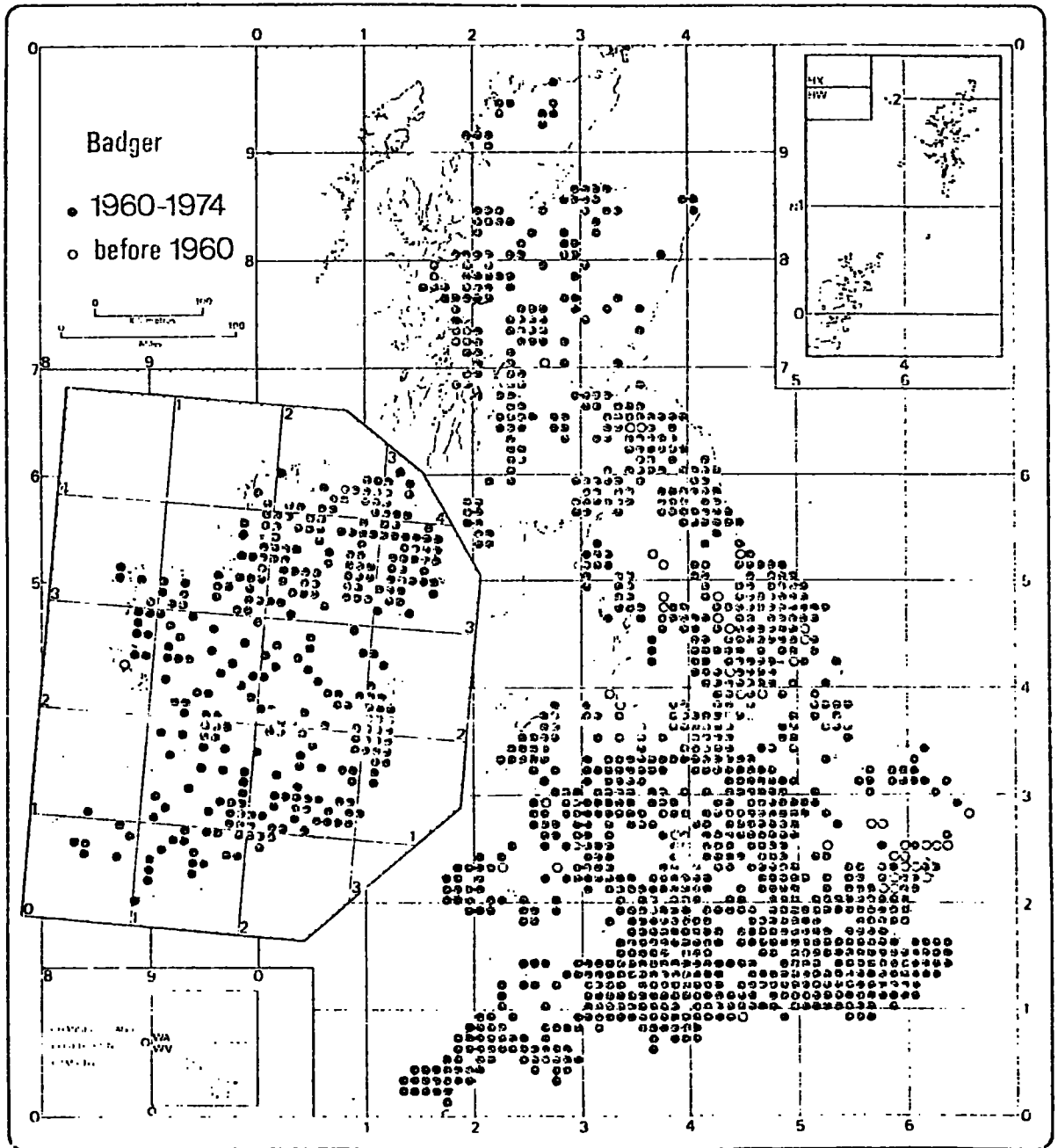

APPENDIX 7.

The home range sizes, weight and McNab's feeding type, taken from McNab (1963, Table 1, p. 134).

Species.	Weight (kilograms).	Home Range (acres).
----- HUNTERS -----		
<u>Didelphis virginiana</u>	3.63	25
<u>Didelphis virginiana</u>	3.63	28.9
<u>Sorex vagrans</u>	0.005	0.09
<u>Blarina brevicauda</u>	0.018	0.05
<u>Blarina brevicauda</u>	0.018	0.087
<u>Mustela rixosa</u>	0.05	2
<u>Procyon lotor</u>	10.89	386
<u>Vulpes fulva</u>	5.45	25
<u>Tamias striatus</u>	0.09	1.6
<u>Tamiascirus hudsonicus</u>	0.185	6.3
<u>Sciurus niger</u>	0.953	25
<u>Sciurus niger</u>	0.953	13.7
<u>Glaucomys volans</u>	0.061	4
<u>Peromyscus maniculatus</u>	0.02	1.85
<u>Peromyscus maniculatus</u>	0.02	0.74
<u>Peromyscus leucopus</u>	0.02	0.4
<u>Peromyscus leucopus</u>	0.02	0.25
<u>Reithrodontomys megalotis</u>	0.01	0.58
<u>Reithrodontomys megalotis</u>	0.01	0.52
<u>Reithrodontomys montanus</u>	0.01	0.50
<u>Zapus hudsonicus</u>	0.02	0.90
<u>Zapus hudsonicus</u>	0.02	2.00
<u>Napeozapus insigis</u>	0.024	1.5
<u>Mus muscalis</u>	0.018	0.41

Species.	Weight (kilograms).	Home Range (acres)
----- <u>CROPPERS</u> -----		
<u>Castor canadensis</u>	20.41	8
<u>Synaptomys cooperi</u>	0.02	0.3
<u>Microtus pennsylvanicus</u>	0.045	0.25
<u>Microtus ochrogaster</u>	0.03	0.18
<u>Pitymys pinetorum</u>	0.028	0.30
<u>Pitymys pinetorum</u>	0.028	0.09
<u>Sigmodon hispidus</u>	0.12	0.55
<u>Sylvilagus floridanus</u>	1.58	8.34
<u>Sylvilagus floridanus</u>	1.58	15
<u>Sylvilagus floridanus</u>	1.36	5
<u>Lepus americanus</u>	1.587	10
<u>Alces americana</u>	358.3	100