



## Durham E-Theses

---

### *Part I anionic groups in metal carbonyl systems Part II anionic polynuclear carbonyl derivatives of iron*

Farmery, Keith

#### How to cite:

---

Farmery, Keith (1968) *Part I anionic groups in metal carbonyl systems Part II anionic polynuclear carbonyl derivatives of iron*, Durham theses, Durham University. Available at Durham E-Theses Online:  
<http://etheses.dur.ac.uk/8776/>

#### Use policy

---

The full-text may be used and/or reproduced, and given to third parties in any format or medium, without prior permission or charge, for personal research or study, educational, or not-for-profit purposes provided that:

- a full bibliographic reference is made to the original source
- a [link](#) is made to the metadata record in Durham E-Theses
- the full-text is not changed in any way

The full-text must not be sold in any format or medium without the formal permission of the copyright holders.

Please consult the [full Durham E-Theses policy](#) for further details.

---

Academic Support Office, Durham University, University Office, Old Elvet, Durham DH1 3HP  
e-mail: [e-theses.admin@dur.ac.uk](mailto:e-theses.admin@dur.ac.uk) Tel: +44 0191 334 6107  
<http://etheses.dur.ac.uk>

PART I ANIONIC GROUPS IN METAL CARBONYL SYSTEMS

PART II ANIONIC POLYNUCLEAR CARBONYL DERIVATIVES

OF IRON

A thesis submitted  
to the  
University of Durham  
for the degree of  
Doctor of Philosophy

by

Keith Farmery, B.Sc.

July 1968



MEMORANDUM

The work described in this thesis was carried out in the University of Durham between October 1965 and July 1968. It has not been submitted for any other degree and is the original work of the author except where acknowledged by reference.

A preliminary report of part of the work described in Part II of this thesis has been published:

"The structure of the  $[\text{Fe}_2(\text{CO})_8\text{H}]^-$  anion"

by K. Farmery, M. Kilner, N.N. Greenwood and R. Greatrex,  
Chem. Comm., 1968, p.593.

## ACKNOWLEDGEMENTS

I wish to express my sincere gratitude to Dr. M. Kilner, under whose supervision this research was carried out, for his constant encouragement and valuable advice. My thanks are also due to Dr. K. Wade for many valuable suggestions and helpful discussions while diphenylketimino complexes were being studied.

I should also like to thank Professor N.N. Greenwood, without whose collaboration, Part II of this thesis would not have been possible, and to Mr. R. Greatrex for recording and helping in the interpretation of the Mossbauer spectra discussed in Part II.

I am indebted to the Science Research Council for a maintenance grant.

K. Farmery.  
Durham. 1968.

## SUMMARY

### PART I

Attempts to introduce organosulphur and diphenylketimino anionic ligands into metal carbonyl systems are described.

Metathetical reactions between iron tetracarbonyl diiodide and mercaptans do not give the expected products. Unstable compounds containing carbonyl, organosulphur and iodine ligands are formed, the complex isolated from the reaction with isopropyl thiol being the unusual, dinuclear iron(II) derivative  $\text{Fe}_2(\text{CO})_5(\text{SPr}^i)_3\text{I}$ , for which a structure with three bridging SR groups is proposed.

The known complexes  $[\text{Fe}(\text{CO})_3\text{SR}]_2$  are formed by simultaneous elimination of hydrogen and carbon monoxide from the reaction of iron carbonyl hydride and mercaptans. Attempts to stabilise the hydride caused initial elimination of hydrogen, rather than carbon monoxide, the products being  $\text{Fe}(\text{CO})_4\text{L}$  and  $\text{Fe}(\text{CO})_3\text{L}_2$  (L = triphenylphosphine or triphenylarsine). However, a minor product, formulated as  $\text{Fe}(\text{CO})_4\text{H}_2\text{AsPh}_3$  is also formed when triphenylarsine is used; a structure in which the iron and arsenic atoms are bound via two hydrogen-bridges is proposed.

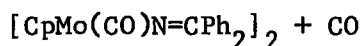
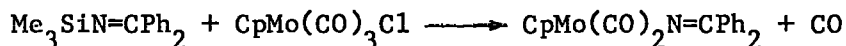
Reactions between derivatives of diphenylketimine and several metal carbonyl systems have been studied, and derivatives of



manganese and molybdenum are described. Different products are obtained from  $\pi\text{-C}_5\text{H}_5\text{Mo(CO)}_3\text{Cl}$  using  $\text{Ph}_2\text{C=NLi}$  or  $\text{Ph}_2\text{C=NSiMe}_3$  according to



I



II

I is thought to be an unexpected pseudoallyl complex, which could not be prepared by a conventional route. In II, very strong Mo-Mo interaction via the  $(\text{C-N})\pi^*$  system is proposed. Iodine, in monoglyme, oxidises II to an oxo species, whose mass spectrum indicates a trinuclear formulation,  $(\pi\text{-C}_5\text{H}_5)_3\text{Mo}_3\text{I}_3\text{O}_4$ .

An explanation is offered for the non-formation of ketimino complexes from N-bromodiphenylketimine ( $\text{Ph}_2\text{C=NBr}$ ).

## PART II

A series of mono-, di-, tri-, and tetranuclear carbonyl and hydrido-carbonyl species of iron have been studied by infrared and Mossbauer spectroscopy. (The Mossbauer spectra being measured, in this joint study, by Professor N.N. Greenwood and R. Greatrex of

Newcastle University). Structures are proposed for these species, and structural and spectral trends are discussed. Some new inter-conversions between the different series are reported.



## CONTENTS

### PART I

	Page
<u>CHAPTER ONE</u> Anionic Ligands in Metal Carbonyl Systems	
1.    General Introduction	1
2.    Anionic Ligands	7
3.    Factors Affecting the Formation of Ligand Bridges	12
4.    Survey of Compounds Containing Anionic Ligands	16
<u>CHAPTER TWO</u> Iron Carbonyl Complexes Containing the Mercaptide Ligand	
1.    Introduction	34
2.    Experimental	37
3.    Discussion	48
4.    Conclusion	50
<u>CHAPTER THREE</u> Some Aspects of the Chemistry of Iron Tetracarbonyldihydride	
1.    Introduction	52
2.    Preparation of $\text{Fe}(\text{CO})_4\text{H}_2$	56
3.    Reaction between Iron Carbonyl Hydride and Mercaptans	57
4.    Reactions of Iron Carbonyl Hydride with Triphenylphosphine and Triphenylarsine	62
<u>CHAPTER FOUR</u> Azomethine Derivatives of Metal Carbonyls - Preliminary Investigations	
1.    Introduction	77
2.    Possible Synthetic Routes to Ketimino-Metal Carbonyl Complexes	80

	page
3. Diphenylketimine as a Neutral Base	82
4. Attempts to prepare Diphenylketiminomanganese Carbonyl Complexes	86
5. Attempts to prepare Cyclopentadienyliron Carbonyl-imino Complexes	92
6. Sealed-tube reactions between $[\text{CpMo}(\text{CO})_3]_2$ and Azines	94
7. Photochemical synthesis of $\text{CpMo}(\text{CO})_3\text{Hal}$ and $\text{CpFe}(\text{CO})_2\text{Hal}$	95

CHAPTER FIVE  $\pi$ -Cyclopentadienylmolybdenum Carbonyl Complexes  
Containing Organo-nitrogen Ligands

1. Reaction between Cyclopentadienylmolybdenum tricarbonyl halides and Diphenylketiminolithium	99
2. Reactions of $\text{Ph}_2\text{C}=\text{NBr}$	111
3. Reactions between $\text{CpMo}(\text{CO})_3\text{Cl}$ and $\text{Me}_3\text{SiN}=\text{CPh}_2$	116
4. Conclusions	128

PART II

CHAPTER SIX Principles of Mossbauer Spectroscopy

1. The Mossbauer Effect	130
2. The Isomer (or Chemical) Shift, $\delta$	135
3. Quadrupole Splitting, $\Delta$	139
4. Magnetic Hyperfine Coupling	142

CHAPTER SEVEN The Application of the Mossbauer Effect to Iron Carbonyl Chemistry

1. The Binary Carbonyls	144
2. Substituted Iron Carbonyls	148

	page
3. Olefin Substituted Carbonyls and Related Compounds	151
4. Organotin-iron Compounds	153
5. Conclusions	156

CHAPTER EIGHT Experimental Techniques of Mossbauer Spectroscopy

1. Sources	161
2. Absorbers	161
3. Cryostat and Sample Holder	162
4. Velocity Modulator	163
5. Gamma Ray Detector	164
6. The $^{57}\text{Co}$ Energy Spectrum	164
7. Calibration of the Velocity Scale	164
8. Treatment of Data	165

CHAPTER NINE Structural Studies of Carbonyl and Hydrido-carbonyl  
Species of Iron

1. Introduction	166
2. Preparation of the Compounds used for Spectroscopic Study	170
3. Results and Discussion	179
a) Mononuclear Species	179
b) Dinuclear Anions	187
c) Trinuclear Anions	192
d) Tetranuclear Species	196
4. Discussion	201

Appendix 1	Experimental Details and Starting Materials	i
"	2 Instrumentation	v
"	3 Analytical Methods	vii
"	4 Calculation of Isotope Patterns	ix

References for Part I

References for Part II

PART I

ANIONIC GROUPS IN METAL CARBONYL SYSTEMS

CHAPTER ONE

Anionic Ligands in Metal Carbonyl Systems

## 1. General Introduction

In the last decade, several reviews of the chemistry of metal carbonyls and related topics have been published. Some of the more important of these concern the binary carbonyls,<sup>1-3</sup> anionic carbonyl metallates,<sup>4,5</sup> metal olefin complexes,<sup>6,7</sup> tricarbonyl(diene)iron species,<sup>8</sup> perfluoroalkyl metal compounds,<sup>9</sup>  $\pi$ -cyclopentadienyl and  $\pi$ -arene metal derivatives,<sup>10,11</sup> sulphur containing metal carbonyls,<sup>12</sup> and Lewis base metal carbonyl complexes.<sup>13</sup> The use of metal carbonyls in organic synthesis is the subject of a book in two volumes.<sup>14</sup>

The purpose of this chapter is to discuss those derivatives of transition metal carbonyls in which formally anionic electron-donating groups are present. Particular reference will be given to those ligands which can bond terminally or can further donate an electron-pair to a second metal atom with the formation of a bridged dimeric or polynuclear species. This aspect of metal carbonyl chemistry is the subject of the work to be described in Part I of this thesis.

The ligand atoms to be considered are mainly those in the fifth, sixth and seventh main groups of the periodic table. The discussion is therefore limited to those elements which form electron-pair two-centre bonds. Hydrogen, which bridges because of its ability to become involved in three-centre electron deficient bonding will not be

discussed, nor will the many organic ligands which are known in this general area of transition metal chemistry, whether they form complexes of the  $\pi$ -type, or involve a  $\sigma$ -bonded carbon atom.

a) The Inert Gas Rule

Foremost among the long recognised regularities of the chemistry of the metal carbonyls and their derivatives is the adherence of the vast majority of compounds to the "effective atomic number" or "rare-gas rule". Namely, the central metal atom accepts a number of additional electrons from its surrounding ligands so that it achieves a formally closed-shell configuration. This simple rule is so successful in predicting the stoichiometry of complexes that the few compounds which do not conform are still considered to be exceptions. (Thus, for Pt and Pd, there is evidence that 16 electrons is the most stable grouping of electrons).

The inert-gas formalism can be applied whatever types of ligands are involved, but it should be noted that many compounds can be considered in at least two ways for the purpose of this electron-counting procedure. For example, the compound  $\text{Fe}(\text{CO})_4\text{I}_2$  may be considered to be composed of

(i) Fe (0) (8 electrons), two  $\text{I}^\cdot$  radicals (2 x 1 electrons) and four carbonyl groups (4 x 2 electrons) or

(ii) Fe (II) (6 electrons), two  $\text{I}^-$  anions (2 x 2 electrons) and the carbonyl groups. In either case there is no net charge on the

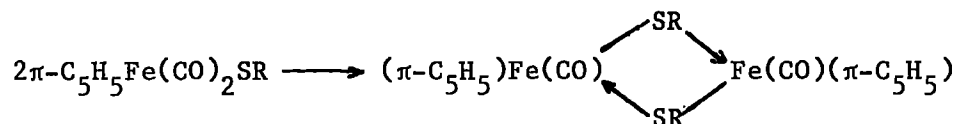
complex, and the total number of electrons is 18. The apparent difference in formal oxidation state of the central atom has little real meaning in most cases - oxidation states often being assigned to the metal only in order to facilitate the electron-counting procedure.

In the compounds to be discussed in this and later chapters, the ligands are considered to be anions, thus donating two electrons to the metal atom in the formation of a co-ordinate bond. In other words the donor atom will be considered to have a complete octet of outer electrons. This is an arbitrary choice, mainly decided upon to concur with the formalism implied by most of the methods of preparation used in this work. However, many of these ligands are often considered to be radicals forming a covalent bond with the metal, since they can be formed in reactions involving homolytic cleavage of an initial reagent (e.g.  $R_2S_2$  or  $R_4P_2$ ).

Polynuclear, but particularly binuclear species, are common among the metal carbonyls and their derivatives. In the simplest cases, the only interaction between the two halves of the complex is a metal-metal bond (e.g.  $Mn_2(CO)_{10}$ ), but in others, bridging carbonyl groups are also involved (e.g.  $Co_2(CO)_8$ ). Bidentate ligands, which are more normally encountered in a chelating capacity, are also known to act as bridges (e.g.  $Fe(CO)_4PR_2 \cdot CH_2CH_2 \cdot R_2PFe(CO)_4$ ).<sup>15,16</sup> Many ligands can co-ordinate to a metal carbonyl system and still retain one or more lone-pairs of electrons on the ligand atom. These electron pairs are



available for co-ordination to a second metal atom to form a bridged complex, usually with elimination of CO, e.g.<sup>17</sup>



and it is this type of system which will form the subject of this chapter.

In some cases, both ligand-bridges and a metal-metal bond are required in order to satisfy the inert-gas rule. For example, a group of compounds of composition  $[\text{Fe(CO)}_3\text{SR}]_2$ <sup>18</sup> are diamagnetic, whereas an electron-count gives a total of only 17, so a metal-metal bond would complete the electron shell and explain the diamagnetism. X-ray studies<sup>19</sup> and other physical measurements<sup>20</sup> have verified this proposal.

#### b) Metal-Ligand Bonding

Most ligands found in substituted metal carbonyls possess both  $\sigma$ -donor and  $\pi$ -acceptor properties, as does CO itself. The acceptor ability of the heavier atoms in a group is a consequence of empty d-orbitals which will accept electrons from filled d-orbitals on the metal. This  $d\pi$ - $d\pi$  interaction will both reduce the electron-density on the metal atom and strengthen the M-L bond. Those ligands which donate via a first row atom generally form less robust derivatives

because, lacking suitable low-lying empty orbitals, they can function only as electron donors. Unsaturated heterocyclic compounds, form more stable complexes because the ligand system as a whole can act as a  $\pi$ -acceptor. In these cases the empty  $\pi$ -orbitals of the ring-system are available for overlap with the non-bonding metal orbitals, and so a synergic interaction is possible, with consequent strengthening of the M-L bond. The large majority of ligands found in metal carbonyl chemistry, then, are the Class B ligands of Ahrland et al.<sup>21</sup> and generally are better  $\sigma$ -donors, but poorer acceptors than the carbonyl groups they replace.

The electron density on the transition metals is generally such that they are able to participate in this type of double-bonding; vacant orbitals (s, p and d) are available to accept  $\sigma$ -donation, while non-bonding orbitals (d) are at least partly filled, and can thus be used for  $\pi$ -back donation. This effective electron-density is determined initially by the position of the atom in the transition series, and its valence state. Clearly the number of electrons in non-bonding d-orbitals after  $\sigma$ -electron acceptance affects the ability of the metal to form strong  $\pi$ -bonds, and so the presence of a positive charge on the central atom increases its acceptor ability, but decreases its back-bonding capacity. The opposite effects are produced by a negative charge. As double-bonding of this synergic type appears essential for the formation of the carbonyls and their

derivatives, most of these compounds are found in low valence states.

A second feature of great importance in the consideration of this kind of complex is the effect of symmetry upon the formation of  $\pi$ -bonds between a metal and the ligands.<sup>22,23</sup> Let us consider an octahedral complex whose central metal atom has the configuration  $(t_{2g})^6 (e_g)^0$ , e.g. Cr, Mo, W. The metal atom has six empty  $sp^3d^2$  orbitals which can accept electron-pairs from the ligands, the d-orbitals involved being the  $d_{x^2-y^2}$  and the  $d_{z^2}$  orbitals, which are directed towards the ligands. Each doubly occupied  $d_{xy}$ ,  $d_{yz}$  and  $d_{xz}$  orbital, on the other hand, is directed between the ligands towards unoccupied ligand orbitals of the same symmetry (i.e. d or  $\pi^*$  orbitals). Thus the general symmetry of the octahedral complex is such that there will be maximum back-bonding.

Filled orbitals are always available, but their number, and the extent to which they are involved in  $\pi$ -bonding depends on the structure of the particular complex considered. In a trigonal bipyramidal 5-co-ordinate complex, for example, the s, p and  $d_{z^2}$  orbitals are involved in  $\sigma$ -bonding, leaving the other d-orbitals available for  $\pi$ -bond formation. In Fe(O) complexes (e.g.  $Fe(CO)_5$ ), all the non-bonding orbitals will be doubly occupied, so maximum  $\pi$ -bonding can occur. Thus 5-co-ordinate iron(0)carbonyl complexes are common.

Since the ligands in any complex must compete for the bonding

potentialities of the central atom, any particular metal-ligand interaction is affected by the nature of the other ligands present, and so the stability depends on the  $\sigma$ - and  $\pi$ -bonding capabilities of the other ligands and of the metal. Thus, the M-C bond order in the series of octahedral complexes  $M(CO)_{6-n}L_n$  [ $n = 0-3$ ,  $L = \sigma$ -donor only] increases as  $n$  increases to three, because the metal  $d\pi$ -electrons become more freely available to the remaining M-C bonds which therefore increase in stability as carbon monoxide is lost. This is the reason why successive replacement of CO becomes progressively more difficult, so for any metal there tends to be an especially stable combination of ligands, balanced according to their  $\sigma$ - and  $\pi$ -bonding capacities and those of the metal.

## 2. Anionic Ligands

### a) Introduction

All the concepts outlined above apply equally well to both anionic and neutral ligands. In addition, whenever a neutral ligand or CO is replaced by an anionic group, there is a consequent increase in the oxidation state of the metal, and so there will be fewer non-bonding electrons to participate in  $\pi$ -bonding. Since this is essential for the existence of carbonyl complexes, the more anionic groups there are bound to the central metal atom, the lower is the probability of the existence of carbonyl species. Thus, the highest commonly encountered oxidation state of the metal atom in carbonyl complexes is three.

Indeed, very few complexes of higher oxidation states are known. One compound of interest in this context is the yellow volatile  $\text{Pt}(\text{CO})_2\text{F}_8$  prepared by Sharp,<sup>24</sup> which, if a true fluorocarbonyl, would be a 10-co-ordinate Pt(VIII) complex; its stability is thought to be due to  $\pi$ -electron donation from the fluoride ligands on to the metal, whose electron-deficiency is thereby relieved. Jørgenson has suggested<sup>25</sup> an ionic formulation  $[\text{COF}]_2[\text{PtF}_6]$ , although Sharp observed no C-F bands in the infrared spectrum.

Infrared data on metal carbonyl systems in general are very helpful for structural considerations. The number, intensity, and positions of the CO stretching bands can often be readily interpreted in terms of the symmetry of the complex and the type of bonding that exists between the metal and the CO groups, and therefore, by implication, between the metal and the ligands, although certain limitations of the methods have to be taken into account. For example accidental coincidence of bands, or the splitting of degenerate modes when the molecules are not independent of each other often occur.

The CO stretching frequency is a measure of the different bonding capabilities of the ligands present, since it depends on the C-O bond order. This reflects M-C double-bonding which in turn is dependent upon the nature of other ligands present. Thus the inductive effect of strongly electronegative groups such as halide ions raise the CO frequency above that in the unsubstituted carbonyls,<sup>26</sup> while ligands

which are poor  $\pi$ -acceptors lower the CO frequency. This type of consideration has received much attention and comparisons of the effects of many ligands have been studied.<sup>13</sup>

b) Methods of Preparation

Although the number of ways of incorporating anionic groups in a metal carbonyl derivative is limited only by the originality of the experimenter, there are certain methods which have found wide application in systematic attempts to prepare new compounds.

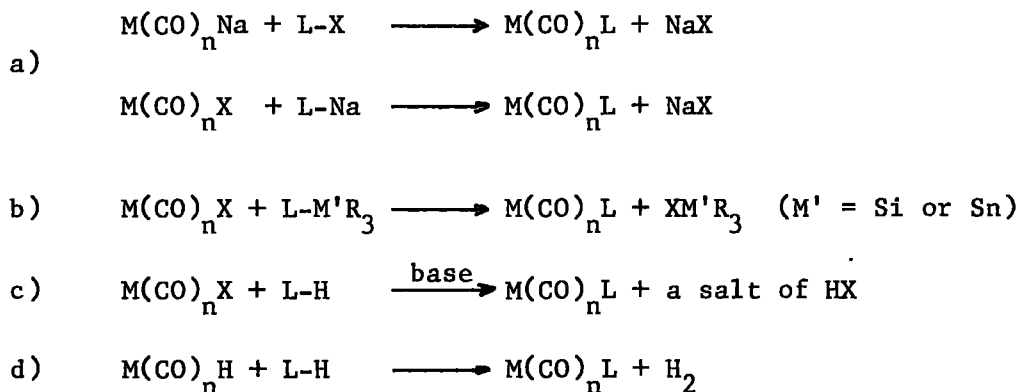
(i) Carbonylation: The direct reaction of CO with a transition metal complex which contains the anionic ligand is perhaps the most obvious route to these derivatives, and has been widely used to prepare metal carbonyl halides, particularly of the second and third row Group VIII metals. Both molecular and ionic complexes have been prepared using the appropriate metal-halogen compound under conditions varying from very mild to those encountered in an autoclave, so it is somewhat surprising that this method has not been more widely used.

Further, the use of transition metal complexes, especially organometallic and carbonyl compounds containing neutral or anionic Lewis bases as catalysts in the high pressure polymerisation and carbonylation processes is increasing, and in the logical sequence by which their role in these reaction is studied, the isolation of the intermediate species becomes important.

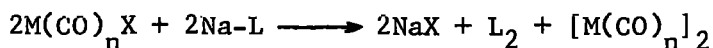
(ii) Homolytic Cleavage Methods. The principle of this method is

that homolytic dissociation of a molecule A-A into radicals A·, in the presence of a metal carbonyl complex, can be followed by oxidation of the metal atom, as it combines with the radicals. This is particularly useful when a metal-metal bond is present in the metal carbonyl system, because mononuclear species can be generated without loss of CO. For example, the halides of manganese carbonyl and many derivatives of  $[\text{CpMo}(\text{CO})_3]_2$  and  $[\text{CpFe}(\text{CO})_2]_2$  are made this way. Some of the substrates which have been used are the halogens,  $\text{R}_4\text{P}_2$ ,  $\text{R}_4\text{As}_2$ ,  $\text{R}_2\text{S}_2$  etc. Almost invariably these reactions have to be initiated either thermally or photochemically, and so the tendency for groups such as RS or  $\text{R}_2\text{P}$  to bridge will be high, and in fact no terminally bound RS groups have yet been found in the products of this type of reaction.

(iii) Ligand Exchange Reactions. The factors affecting replacement of a ligand in a complex by a second ligand are well understood. In the case of anionic ligands in metal carbonyl systems, this is usually achieved by a metathetical process and some general reactions of this type are listed below.



Reactions a) and b) are of the same general type; b) has the advantage that  $\text{Me}_3\text{M}'\text{X}$  is either volatile under normal conditions or highly soluble in organic solvents. A possible side reaction which is often a feature of this reaction system (especially a)) is the process by which dimerisation of  $\text{M}(\text{CO})_n$  or L occurs, i.e.



When a particularly stable dimeric carbonyl  $[\text{M}(\text{CO})_n]_2$  is known this reaction often predominates - a good illustration being the standard method of preparation of  $[\text{CpCr}(\text{CO})_3]_2$ ;<sup>27</sup> treatment of  $\text{Na}[\text{CpCr}(\text{CO})_3]$  in THF solution with allyl bromide gives only the dimer above.

Reactions involving elimination of  $\text{HX},(\text{c}),$  is a well established procedure, but is limited in application by the tendency of the amine bases generally used to react with the metal carbonyl halide. In such cases a carbonate can sometimes be used successfully.

Most of these metatheses occur under much milder conditions than (i) or (ii), the advantage being that thermally unstable complexes can thus be made. For example, all the terminal mercaptide groups have been introduced into metal carbonyl systems by this method. In this context, the highly reactive metal carbonyl hydrides will often allow isolation of this type of product at or below room temperature, and therefore afford the best chance of preparation of the most unstable derivatives.



### 3. Factors Affecting the Formation of Ligand Bridges

As already described, the anionic ligands under discussion have lone pairs of electrons which are available for  $\sigma$ -donation to more than one metal (In this context the terms "mono-, bi- and tri-metallic ligands" have sometimes been used according to the numbers of metal atoms bridged by the particular ligand). The situation in which a ligand finds itself will depend amongst other things on the properties of the ligand itself, and of the metal to which it is coordinated. Some of these factors are discussed below.

#### a) $\sigma$ -Donor Characteristics of the Ligand

Within each period of the Periodic Table, the electronegativity of the donor atom has the major influence on its  $\sigma$ -donor ability, although its effective electronegativity will be influenced by the groups attached to it. Thus, metal carbonyl fluorides are unknown because the very high electronegativity of fluorine precludes the formation of bonds which are mainly covalent in nature. In addition, there will be a reduction in the electron-density on the donor atom as one pair of electrons is donated to a metal, and other electron-pairs will therefore be less able to co-ordinate to additional metal atoms. This factor, together with the high electronegativity of the halogens is probably responsible for the halides showing the lowest tendency to bridge two or more metal carbonyl fragments. Indeed, there are no triply-bridging halogens known in metal carbonyl chemistry, although

they are found in some of the transition metal-halogen cluster species (e.g.  $\text{Mo}_6\text{Cl}_8^{2+}$ ).<sup>28</sup> On the other hand, all the different types of bridging behaviour expected of sulphur-containing ligands have now been verified by X-ray crystallography; the RS ligand has been found attached to 1, 2 and 3 metal atoms, and sulphur itself to 2, 3 and 4.<sup>29</sup>

The  $\sigma$ -donor properties of a ligand will be markedly affected by the groups bonded to the donor atom. Electron withdrawing groups, such as perfluoroalkyl groups, will reduce its ability to donate, and several illustrations of this behaviour are available. Probably the most dramatic is that  $(\text{CF}_3)_2\text{As}^-$  forms the only known monomeric dialkylarsenidometal carbonyl derivative  $\text{CpFe}(\text{CO})_2\text{As}(\text{CF}_3)_2$ ;<sup>30</sup> all other  $\text{R}_2\text{As}$  groups act as bridging ligands. (Dimerisation of  $\text{CpFe}(\text{CO})_2\text{As}(\text{CF}_3)_2$  is effected by u.v. irradiation). A distinct trend in the stabilities of monomeric mercapto-derivatives has also been noted,<sup>31</sup> and is summarised in Table 1-1, in which the halides are included for comparison. The tendency to dimerise is directly related to the basicity of the S atom, which decreases from alkyl to aryl to perfluoroalkyl, so that the  $\text{C}_6\text{F}_5\text{S}^-$  group may be regarded as a pseudohalide.

b) Formation of Metal-Ligand  $\pi$ -bonds

The synergic interactions described earlier are equally important for bridged complexes, the only difference being that the same empty orbitals on the ligand are used to accept electrons from both metals,

and so one would expect the M-L double-bond character to be slightly less in the dinuclear case because of electron-repulsion.

Table 1-1

Dimerisation Tendencies of Organothiometal carbonyls.

$[\text{Mn}(\text{CO})_5\text{SR}]$	$[\text{Mn}(\text{CO})_5\text{SPh}]$	$\text{Mn}(\text{CO})_5\text{SC}_6\text{F}_5$	$\text{Mn}(\text{CO})_5\text{X}$
$[\text{Re}(\text{CO})_5\text{SR}]$	$[\text{Re}(\text{CO})_5\text{SPh}]$	$\text{Re}(\text{CO})_5\text{SC}_6\text{F}_5$	$\text{Re}(\text{CO})_5\text{X}$
$\text{CpMo}(\text{CO})_3\text{SR}$	$\text{CpMo}(\text{CO})_3\text{SPh}$	$[\text{CpMo}(\text{CO})_3\text{SC}_6\text{F}_5]$	$\text{CpMo}(\text{CO})_3\text{X}$
$\text{CpW}(\text{CO})_3\text{SR}$	$\text{CpW}(\text{CO})_3\text{SPh}$	$[\text{CpW}(\text{CO})_3\text{SC}_6\text{F}_5]$	$\text{CpW}(\text{CO})_3\text{X}$
$\text{CpFe}(\text{CO})_2\text{SR}$	$\text{CpFe}(\text{CO})_2\text{SPh}$	$\text{CpFe}(\text{CO})_2\text{SC}_6\text{F}_5^*$	$\text{CpFe}(\text{CO})_2\text{X}$
$\text{L}_2\text{Rh}(\text{CO})\text{SR}^*$	$\text{L}_2\text{Rh}(\text{CO})\text{SPh}^*$	$\text{L}_2\text{Rh}(\text{CO})\text{SC}_6\text{F}_5^*$	$\text{L}_2\text{Rh}(\text{CO})\text{X}^*$

→ Increasing stability and decreasing tendency to dimerise

\* No known dimer

[ ] denotes unknown monomer

L =  $\text{Ph}_3\text{P}$

X = halogen, R = alkyl group.

c) The Nature of the Groups attached to the Metal

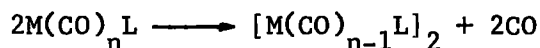
When a system  $\text{M}(\text{CO})_n\text{L}$  dimerises by formation of M-L-M bridges, the process must be accompanied by either CO evolution (with formation of  $[\text{M}(\text{CO})_{n-1}\text{L}]_2$ ) or an increase in the co-ordination number of the metal.

If, therefore, the M-CO bond is very strong as a result of the presence of other groups in the complex, the dimerisation tendency will be minimal. As an example, further substitution of CO in  $\text{Re}(\text{CO})_3\text{L}_2\text{X}$  is difficult<sup>13</sup> for the reasons already discussed, and so the complex  $\text{Re}(\text{diphos})(\text{CO})_3\text{SR}$  is a quite stable monomer,<sup>32</sup> and, interestingly, when  $\text{Re}(\text{CO})_3(\text{PPh}_3)_2\text{X}$  reacts with thiols, dimerisation occurs, but with the displacement of  $\text{Ph}_3\text{P}$ , to give  $[\text{Ph}_3\text{PRe}(\text{CO})_3\text{SR}]_2$ .<sup>33</sup> (see section d).

For the large majority of the metal carbonyls, there is no evidence that bridging by increasing the metal co-ordination state is a favoured process, generally because this would involve exceeding the inert-gas configuration.

d) Thermodynamic Factors.

The formation of ligand-bridged species by CO evolution according to the general equation



is favoured by the fact that the  $\Delta S^\circ$  term for the system would be more positive for the right hand side as the number of free molecules (i.e. the extent of disorder) increases. (This is similar to the 'chelate effect' in co-ordination chemistry<sup>34</sup>). However, the evidence available indicates that the contribution of the  $\Delta H^\circ$  term, attributable mainly to the difference in bond energies of the M-CO bonds broken and new M-L bonds formed, is generally much more important. For example,

when several CO groups are present in a complex, ligand substitution reactions tend to proceed via a dissociative mechanism (e.g. the manganese pentacarbonyl halides initially lose CO)<sup>35-7</sup> showing that one CO group is weakly bound, and so, in such cases, the bond energy terms will be most important. This will apply in all those cases in which the number of L and CO groups in a complex is not the one most favoured from a consideration of  $\pi$ -bonding characteristics. However, when this stable system is present, the  $\Delta S^\circ$  term could become more important, and one example of this behaviour is known.<sup>33</sup>



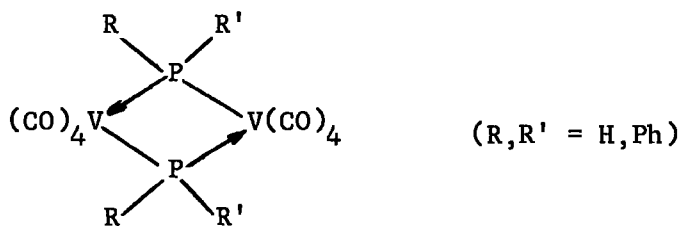
in which the preferred  $\text{Mn}(\text{CO})_3$  fragment is retained while  $\text{Ph}_3\text{P}$ , despite being a stronger ligand than terminal R-S groups,<sup>38,39</sup> is eliminated.

#### 4. Survey of Compounds Containing Anionic Ligands

In this survey, emphasis will be placed on those ligands which can form bridged complexes, and particular attention will be given to the factors affecting the stability of these derivatives compared with the non-bridged precursor. Comparisons between similar compounds containing different anionic ligands will be made, and attention drawn to obvious omissions in the general pattern.

a) Vanadium

The tendency of  $V(CO)_6$  to complete its outer shell is responsible for the the disproportionation reactions of this carbonyl with N and O bases to produce  $[V(CO)_6]^-$ . Tertiary phosphines, however, give either paramagnetic trans- $[V(CO)_4(PR_3)_2]$  or diamagnetic dimers  $[V(CO)_4(PR_3)_2]_2$  depending on R.<sup>40,41,42</sup>  $PH_3$ ,  $RPH_2$  or  $R_2PH$  on the other hand lose hydrogen with formation of phosphide-bridged dimeric V(I) complexes I.<sup>41</sup>



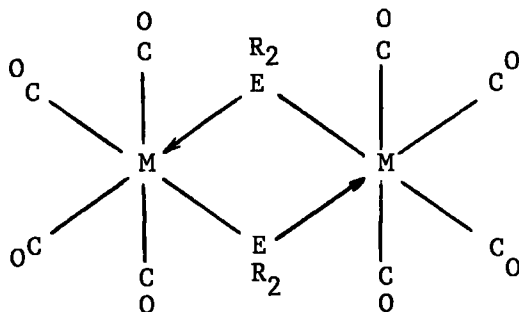
I

There are no simple vanadium carbonyl halides, but  $[VI(CO)_4(diars)]$  is formed from  $[V(CO)_4(diars)]$  and  $I_2$ .<sup>43</sup> This complex is a hepta-co-ordinate 18-electron molecule and is therefore analogous to the Cr, Mo and W complexes to be discussed later. Displacement of all the CO groups from  $CpV(CO)_4$  is caused by  $Me_2S_2$ <sup>44</sup> and bis(trifluoromethyl)-dithietene,<sup>45</sup> with the formation of dimeric complexes, e.g.  $[CpV(SMe)_2]_2$  which probably have four bridging organo-sulphur groups.

b) Chromium, Molybdenum and Tungsten

This group of metals illustrates very clearly the instability of non-18-electron complexes. The only neutral halides are  $\text{Cr}_2\text{I}(\text{CO})_{10}$ ,<sup>46</sup> the paramagnetic species  $\text{Cr}(\text{CO})_5\text{X}$  ( $\text{X} = \text{I}, \text{CN}, \text{SCN}$ )<sup>47</sup>, and the series of 16-electron halides  $\text{M}(\text{CO})_4\text{X}_2$ .<sup>48-50</sup> All the compounds  $\text{M}(\text{CO})_4\text{X}_2$  are air sensitive and unstable at room temperature, and some could only be characterised as their more stable disubstitution products, which are either of the heptaco-ordinate type  $\text{M}(\text{CO})_3(\text{L}_2)\text{X}_2$  ( $\text{L}_2 =$  bipy or o-phen), or are of stoichiometry  $\text{M}(\text{CO})_2\text{L}_2\text{X}_2$  ( $\text{L} = \text{R}_3\text{P}$  etc.). These last compounds are believed to be dimeric and contain double M-M bonds.

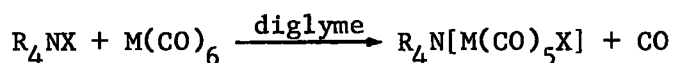
The problem of attaining an 18-electron configuration is overcome by ligand bridging in the series of dinuclear P or As bridged M(I) complexes  $[\text{M}(\text{CO})_4\text{ER}_2]_2$ <sup>51-53</sup> prepared by heating the hexacarbonyl with  $\text{R}_2\text{E}.\text{ER}_2$  to 180-200°C. Their structure (II) is believed to incorporate a metal-metal bond to explain their observed diamagnetism.<sup>51</sup> The mercaptide analogues are unknown.



II

Monomeric 18-electron M(II) complexes would be 7-co-ordinate, and there is now an extensive series of such compounds, prepared by the action of halogens on bidentate-ligand substituted Group VI hexacarbonyls. They can take the form  $[M(CO)_4(L_2)I]^+$ ,  $[M(CO)_3(L_2)X_2]$  or  $[M(CO)_2(L_2)_2X]^+$ , where the bidentate ligand  $L_2$  can be a diarsine,<sup>54-56</sup> a diphosphine,<sup>56</sup> 2,2'-bipyridyl,<sup>57-62</sup> 1,10-phenanthroline<sup>63</sup> and  $C_2H_4(SMe)_2$ .<sup>64</sup>

The complete series of halogenopentacarbonyl metallates  $[M(CO)_5X]^-$  have been prepared by the reaction<sup>65</sup>



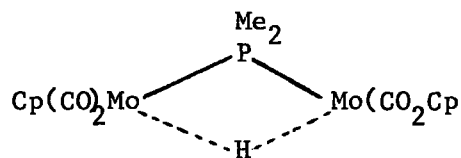
Since this reaction is often quantitative, and the products show their expected stability, this type of reaction is suitable for extension to other salts, and corresponding anions where  $X = NCS^-$ ,<sup>66</sup>  $CN^-$ ,<sup>67</sup>  $NCO^-$ ,<sup>68</sup>  $[C(CN)_3]^-$ ,<sup>69</sup>  $NH_2^-$ <sup>70</sup> and even  $SH^-$ <sup>71</sup> have been prepared, although attempts to prepare the nitro-analogue were unsuccessful.<sup>72</sup> The azide ion, in  $[Et_4N][N_3]$  reacts with  $W(CO)_6$ , but the product is  $[W(CO)_5NCO]^-$ .<sup>73</sup> This is thus an example of nucleophilic attack at a carbonyl group (here followed by loss of  $N_2$ ) first discovered by Kruck et al.<sup>74</sup> Various doubly and triply charged anions  $[M(CO)_{6-n}Y_n]^{n-}$  containing  $CN^-$ <sup>75</sup> and  $R_2P^-$ <sup>76</sup> are known.

A large number of  $\pi$ -cyclopentadienyl metal carbonyl complexes containing anionic groups have been prepared, again probably because the



stability of the  $\text{CpM}(\text{CO})_3\text{Y}$  system is a consequence of the 18-electron rule. The readily available<sup>77,78</sup> halides, or salts  $\text{Na}[\text{CpM}(\text{CO})_3]$ , have been the source of many of these derivatives, and often the same products are obtained by homolytic cleavage of the M-M bond in  $[\text{CpM}(\text{CO})_3]_2$ , although this procedure yields dinuclear complexes with P and S ligands.

No Y-bridged compounds  $[\text{CpM}(\text{CO})_2\text{Y}]_2$  have yet been reported where Y = halogen, but these are the most characteristic mercaptide, dialkylphosphide or dialkylarsenide derivatives, showing the close correspondence between these groups and their greater tendency to bridge than the halides. Thus, treatment of  $[\text{CpMo}(\text{CO})_3]_2$  with  $\text{Me}_4\text{As}_2$  gives solely the bridged complex,<sup>79</sup> but when the highly electronegative  $\text{CF}_3$  group is bound to arsenic, as in  $(\text{CF}_3)_4\text{As}_2$ , the monomeric species  $[\text{CpMo}(\text{CO})_3\text{As}(\text{CF}_3)_2]$  which dimerises only on irradiation is obtained.<sup>80</sup> The same dimeric complexes are available via metathetical reactions,<sup>79</sup> but use of  $\text{Me}_2\text{PCl}$  and  $\text{Na}[\text{CpMo}(\text{CO})_3]$  results in the formation, as a biproduct, of the unusual hydride III.



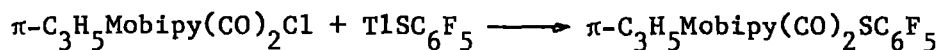
III

The bent, three centre Mo-H-Mo bond,<sup>81</sup> and the bridging phosphide ligand

are also assumed to be present in  $[\text{Cp}_2\text{Fe}_2(\text{PR}_2)(\text{CO})_2\text{H}]$  and  $[\text{Mn}_2(\text{CO})_8(\text{PR}_2)\text{H}]$ .<sup>81</sup> The reaction between  $[\text{CpMo}(\text{CO})_3]_2$  and  $\text{Ph}_4\text{P}_2$  gives the unexpected trimer  $[\text{CpMo}(\text{CO})\text{PPh}_2]_3$ ,<sup>79</sup> which must possess both  $\text{R}_2\text{P}$  bridges and metal-metal bonds.

Although all the CO is lost when  $\text{R}_2\text{S}_2$  and  $[\text{CpMo}(\text{CO})_3]_2$  are heated together<sup>82</sup> (the product being  $[\text{CpMo}(\text{SR})_2]_2$  which is analogous to the vanadium complex described earlier), use of the carbonyl hydrides  $\text{CpM}(\text{CO})_3\text{H}$  gives the tricarbonyl monomers<sup>83</sup>  $\text{CpM}(\text{CO})_3\text{SR}$ , which are also available from the chlorides by reaction with  $\text{NaSR}$ , or  $\text{RSH}$  in the presence of  $\text{Et}_3\text{N}$ .<sup>84</sup> The molybdenum complex readily dimerises on warming and the tungsten complex on irradiation<sup>84</sup>. There is mass spectroscopic evidence for the existence of a trinuclear tungsten species analogous to the phosphorus bridged compound above.<sup>84</sup> These results show particularly well the value of low temperature synthetic routes to compounds which contain ligands with a high bridging propensity.

A stable monomeric  $\pi$ -allyl molybdenum derivative is obtained by the following metathesis<sup>85</sup>



whereas a dinuclear complex containing three SPh bridges is formed on treatment of  $[(\pi\text{-C}_4\text{H}_7)_2\text{Mo}_2(\text{CO})_4\text{Cl}_3]$  with  $\text{NaSPh}$ .<sup>86</sup>

Finally, the phenylazo complex  $\text{CpMo}(\text{CO})_2\text{N}_2\text{Ph}$ , which will be

discussed later, reacts with  $\text{Me}_2\text{S}_2$  to give  $[\text{CpMo}(\text{N}_2\text{Ph})\text{SMe}]_2$  which has bridging sulphur rather than nitrogen atoms.<sup>87</sup>

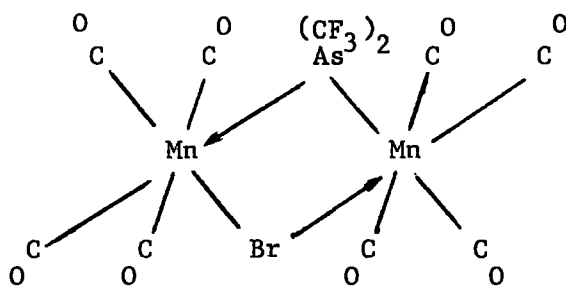
c) Manganese, Technetium and Rhenium

The base-substituted carbonyls of the Group VII metals are more varied in nature than those of Group VI because of the number of different ways the zero-valent atoms can obtain the 11 electrons needed to satisfy the inert-gas rule. The odd number of electrons is overcome if one ligand is  $\pi$ -cyclopentadienyl, or other mono-anion, or if a metal-metal bond is present. In the six-co-ordinate Mn(I) complexes  $\text{Mn}(\text{CO})_5\text{Y}$  (Y = mono-anionic ligand) the electronic configuration of the metal,  $(t_{2g})^6(e_g)^0$ , is ideal for maximum stability, as described earlier, so one would expect a large number of these complexes to exist, just as the corresponding carbonyls of the Cr group of elements give rise to an extensive series of neutral-base substituted complexes.<sup>3,13</sup> Thus, the compounds corresponding to Y = Halogen<sup>88-92</sup>,  $\text{SCN}^{93,94}$ ,  $\text{CN}^{95}$ ,  $[\text{C}(\text{CN})_3]^{96}$ ,  $\text{NO}_3^{97}$ ,  $\text{NO}_2^{97}$  have been prepared, and methyl- and benzyl-manganese pentacarbonyl react with  $\text{SO}_2$  to yield S-sulphinatomanganese pentacarbonyl by  $\text{SO}_2$  insertion.<sup>98</sup>

Kinetic studies of CO exchange<sup>5</sup> and CO substitution<sup>6</sup> reactions of the halides of Mn and Re<sup>7</sup> are consistent in all cases with a dissociative rate-determining step at or just above room temperature. The highly reactive intermediate  $[\text{M}(\text{CO})_4\text{X}]$  then reacts rapidly with any Lewis base present to form the substituted carbonyl halides, but in the

absence of a neutral ligand, dimerisation to  $[M(CO)_4X]_2$  occurs by formation of halogen bridges. Indeed, all the dinuclear tetracarbonyl halides in this group have been prepared by heating solutions of the pentacarbonyl halides.<sup>88,89,99</sup> CO under pressure regenerates the pentacarbonyl halide.<sup>88,99</sup>

In view of these results, it is not surprising that RS-,<sup>100-103</sup> RSe-,<sup>104</sup> R<sub>2</sub>P-<sup>105</sup> and R<sub>2</sub>As-<sup>106,107</sup> derivatives are almost invariably bridged, however prepared, except when the perfluorophenyl mercaptide derivative  $Mn(CO)_5SC_6F_5$  is prepared under mild conditions,<sup>108,109</sup> or when a substituent chelating ligand, such as diphos is present.<sup>108</sup> Even  $(CF_3)_2As$  and  $(CF_3)_2P$  act as bridging ligands within this system, and compounds containing both these and halogen bridges are known (IV).<sup>106,107</sup>



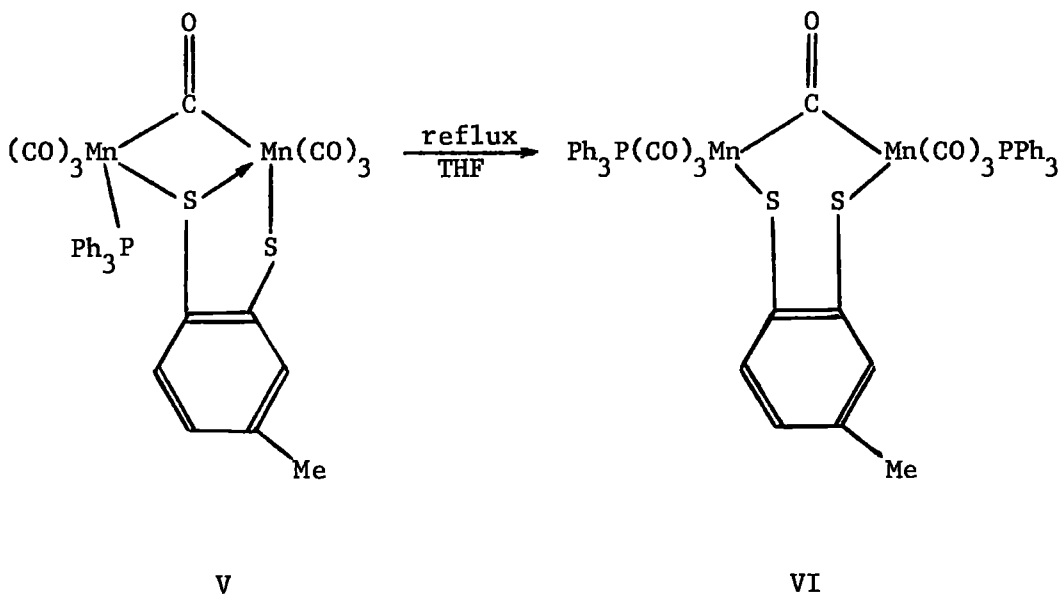
IV

The reaction between  $Mn_2(CO)_{10}$  and  $Ph_3As$  yields the expected paramagnetic mononuclear substitution product  $[Mn(CO)_4(AsPh_3)]$ ,<sup>110</sup> but under more drastic conditions ( $>140^\circ$ ) the unexpected product is the

Ph<sub>2</sub>As-bridged complex [Mn(CO)<sub>4</sub>AsPh<sub>2</sub>]<sub>2</sub>,<sup>111</sup> the lost phenyl group being detected in the solution as benzene.

In the preparations of [Mn(CO)<sub>4</sub>SR]<sub>2</sub>, a second product [Mn(CO)<sub>3</sub>SR]<sub>n</sub> is often present, and can be obtained as the sole product on heating the tetracarbonyl dimer.<sup>112,113</sup> The nature of these products is still the subject of dispute. Originally<sup>112,113</sup> formulated as trimers, they are now known to be tetramers; mass spectroscopy<sup>114</sup> suggests an asymmetric structure, whereas the combination infrared spectrum is only consistent with a structure of T<sub>d</sub> symmetry.

Two very unusual complexes which are believed to contain both bridging carbonyl groups and sulphur ligands (V and VI) are prepared in the reaction between Ph<sub>3</sub>PMn(CO)<sub>4</sub>Cl and CH<sub>3</sub>.C<sub>6</sub>H<sub>3</sub>.(SH)<sub>2</sub>.<sup>116</sup>



The anionic Mn(I) species also illustrate the ease with which ligand-bridges are formed within this group. For Mn, all the mono-nuclear ions  $[\text{Mn}(\text{CO})_4\text{X}_2]^-$  and the dinuclear ions  $[\text{Mn}_2(\text{CO})_8\text{X}_2]^{2-}$  have been prepared,<sup>117</sup> and some of the corresponding Re derivatives are known,<sup>118</sup> so it is to be expected that corresponding S and P bridged anions will be stable also.

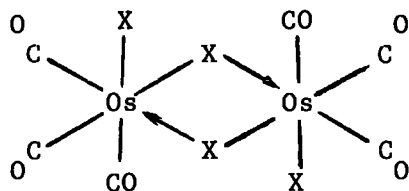
d) Iron, Ruthenium and Osmium

Nitrogen and oxygen bases readily displace CO from the iron carbonyls but disproportionation usually occurs yielding the unsubstituted carbonyl ferrate anions (see Part II) unless indirect synthetic methods are employed. The halogens and ligands which donate via S, Se, Te, P, As and Sb atoms form fairly stable substitution products.<sup>119</sup>

All the tetracarbonyl dihalides  $\text{M}(\text{CO})_4\text{X}_2$  are known for  $\text{M} = \text{Fe}$ <sup>120</sup> or  $\text{Os}$ ,<sup>121</sup> together with the mixed halides  $\text{FeIBr}(\text{CO})_4$  and  $\text{FeICl}(\text{CO})_4$ .<sup>122</sup> They are prepared by the controlled action of the halogens on  $\text{M}(\text{CO})_5$ , and the unstable "adducts"  $\text{Fe}(\text{CO})_5\text{I}$ <sup>123</sup> and  $\text{Fe}(\text{CO})_5\text{I}_2$ ,<sup>124</sup> which are probably intermediates in these reactions have been reported. Dipole moment measurements<sup>125</sup> and infrared spectral properties of the iron<sup>126</sup> and osmium compounds<sup>127-8</sup> confirm a cis-octahedral ( $\text{C}_{2v}$ ) arrangement of groups round the metal.

The polymeric, presumably halogen-bridged dicarbonyl halides  $[\text{M}(\text{CO})_2\text{X}_2]_n$  have been reported for  $\text{Fe}$ ,<sup>122,129</sup>  $\text{Os}$ ,<sup>121</sup>  $\text{Ru}$ ,<sup>130</sup> but

osmium differs from the other two metals by forming a more extensive series of halides with a lower CO content than the parent species  $M(CO)_4X_2$ . Thus,  $Os(CO)_4X_2$  are unstable at  $100^\circ C$  with respect to  $Os(CO)_3X_2$  (VII),<sup>127</sup> which at  $300^\circ C$  loses CO to give  $[Os(CO)_2X_2]_n$ .



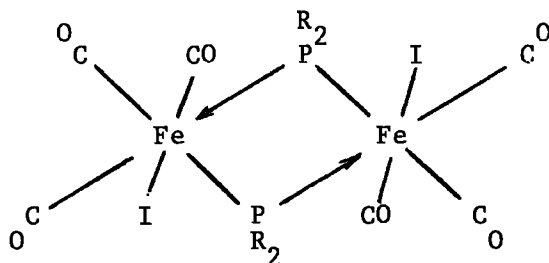
VII

Neutral ligands break the halogen bridges of VII and displace CO;<sup>127</sup> the products ( $Os(CO)_2L_2X_2$ ) are the same as prepared by the action of L on the polymeric dicarbonyls<sup>131-2</sup> or on  $M(CO)_4X_2$ , although in the latter case mono- and di-substitution is also observed.<sup>133</sup> Indeed, the complete series of  $Ph_3P$ -substituted carbonyl iodides  $Fe(CO)_{4-n}L_nI_2$  ( $n = 0-4$ ) have been prepared, and isomeric forms of some of these isolated.<sup>134</sup>

It is surprising, in view of the number and stability of  $Fe(CO)_4L$  species, that the first member of the series of ions  $[Fe(CO)_4X]^-$ , isoelectronic with the well-known  $[Cr(CO)_5X]^-$ , was only recently obtained,<sup>135</sup> in this case by the direct action of  $Et_4NI$  on either  $Fe(CO)_5$  or  $Fe_3(CO)_{12}$ . It has the expected<sup>136</sup> trigonal

bipyramidal structure. The ions  $[\text{Os}(\text{CO})\text{Cl}_5]^{3-}$ ,  $[\text{Os}(\text{CO})_2\text{Cl}_4]^{2-}$  and  $[\text{Os}(\text{CO})_3\text{Cl}_3]^-$  and their phosphine substituted derivatives, based on octahedral Os(II), have been prepared by refluxing the corresponding halide with formic acid.<sup>137</sup> This is an example of the relatively easy carbonylation of the heavier Group VIII metal compounds.

No monomeric iron(I) complexes have been isolated (they would be 'odd-electron' molecules), but many dimeric, ligand-bridged species  $[\text{Fe}(\text{CO})_3\text{Y}]_2$  ( $\text{Y} = \text{R}_2\text{P}$ <sup>138</sup> or RS, RSe, RTe) have been reported. The corresponding complex with one S and P bridge is also known.<sup>139</sup> They are all diamagnetic and so contain a metal-metal bond (see Chapter 2) which is broken by  $\text{I}_2$ ; in the case of  $[\text{Fe}(\text{CO})_3\text{PR}_2]_2$ , complex IX is formed.<sup>140</sup>



IX

The sulphides  $\text{Fe}_2(\text{CO})_6\text{S}_2$  and  $\text{Fe}_3(\text{CO})_9\text{Y}_2$  ( $\text{Y} = \text{S}, \text{Se}, \text{Te}$ ), whose structures have been published<sup>141-3</sup> can be considered to be substitution products of  $\text{Fe}_2(\text{CO})_9$  and  $\text{Fe}_3(\text{CO})_{12}$  respectively. They are prepared in the reactions of  $[\text{Fe}(\text{CO})_4]^{2-}$  with polysulphides. Reaction



between  $\text{Fe}_3(\text{CO})_{12}$  and MeCNS gives, as one of the products, a sulphide  $[\text{Fe}_2(\text{CO})_6\text{SMe}]_2\text{S}$ , which contains both bridging MeS groups and a tetrahedral-like S atom co-ordinated to 4 metals.<sup>144</sup>

Carbonyl mercaptides of Ru, directly analogous to the iron compounds described above are obtained by treatment of  $\text{Ru}_3(\text{CO})_{12}$  with thiols, but, as well as  $[\text{Ru}(\text{CO})_3\text{SR}]_2$ , a polymeric compound  $[\text{Ru}(\text{CO})_2(\text{SR})_2]_n$  analogous to the halides is formed. The corresponding iron compound is only prepared from  $\text{Fe}(\text{CO})_5$  and  $\text{R}_2\text{S}_2$  in an autoclave, but with no added CO.<sup>145</sup>

Recently, a wide range of iron carbonyl derivatives which contain anionic nitrogen-bases has been reported, in which the nitrogen atom has been found bound to 1, 2 or 3 metal atoms (see Chapter 4).

One of the striking similarities in this area of chemistry is the parallel behaviour exhibited by the  $\text{CpMo}(\text{CO})_3^-$  and  $\text{CpFe}(\text{CO})_2^-$  systems. In general, iron compounds corresponding to all the halides, mercaptides, phosphides, etc. of Mo are known, and are usually prepared in exactly the same manner.<sup>146-155</sup> One noticeable difference is the series of singly-bridged, cationic complexes  $[\text{CpFe}(\text{CO})_2\text{-Y-Fe}(\text{CO})_2\text{Cp}]^+$  (Y = I or Br,<sup>156</sup>  $\text{PR}_2$ <sup>157</sup>), of which the corresponding molybdenum derivatives are unknown. On the other hand, the new halides  $\text{CpMo}(\text{CO})_2\text{X}_3$ ,<sup>158</sup> which are non-electrolytes, have no equivalents in iron chemistry.

The first N-bonded anionic organonitrogen derivatives, the N-pyrrolyl<sup>159-160</sup> and N-pyrazole<sup>161</sup> and related compounds have been prepared by metatheses from  $\text{CpFe(CO)}_2\text{I}$ , but no corresponding N-bridged dimeric complexes are known.

e) Cobalt, Rhodium and Iridium

The tetracarbonyl halides  $\text{Co(CO)}_4\text{X}$  are isoelectronic with  $\text{Mn(CO)}_5\text{X}$ , but are so much less stable that their existence has only recently been confirmed (in solution at low temperatures). Their infrared spectra are consistent with a trigonal bipyramidal ( $\text{C}_{3v}$ ) structure.<sup>162</sup> Their phosphine substituted derivatives, however are stable to  $100^\circ$  or higher.<sup>163,164</sup>

Apart from the unstable brown polymer  $[\text{CoI}_2(\text{CO})]_n$ , prepared by the reaction of  $\text{CoI}_2$  with CO under pressure,<sup>165</sup> no lower carbonyl halides are known.  $\text{R}_2\text{P}$ -bridged complexes  $[\text{Co(CO)}_3\text{PR}_2]_2$  were prepared some years ago, however, although there remains uncertainty on the degree of association.<sup>166</sup> The thermal reaction between  $\text{Co}_2(\text{CO})_8$  and  $\text{Ph}_4\text{P}_2$  also gives a trinuclear complex  $[\text{Co}_3(\text{PR}_2)_2(\text{CO})_7]$  which apparently contains both bridging and terminal carbonyl groups.<sup>166</sup>

The reaction between  $\text{Co}_2(\text{CO})_8$  and thiols was originally reported to give the expected  $[\text{Co(CO)}_3\text{SR}]_2$ ,<sup>167</sup> but the work could not be repeated. Very complex behaviour is observed when  $\text{Co}_2(\text{CO})_8$  reacts with sulphur containing compounds, and those products which have been characterised are shown in Table 1-2.

Table 1-2  
Cobalt Carbonyl Sulphides

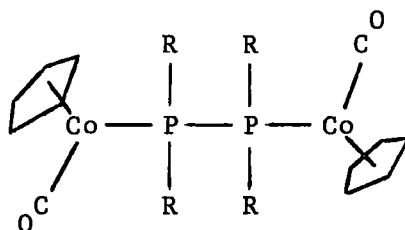
Reactants	Products	Ref.
$[\text{Fe}(\text{CO})_3\text{S}]_2$	$\text{Co}_2\text{Fe}(\text{CO})_9\text{S}$	168
$\text{Fe}(\text{CO})_5$ + any RS compound	$\text{Co}_2\text{Fe}(\text{CO})_9\text{S}$	168
S + CO	$\text{Co}_3(\text{CO})_9\text{S} + [\text{Co}_2(\text{CO})_5\text{S}]_2 + \text{Co}_3(\text{CO})_7\text{S}_2$	169
$\text{H}_2\text{S}$	$\text{Co}_3(\text{CO})_9\text{S} + [\text{Co}_2(\text{CO})_5\text{S}]_2$	170
EtSH or $\text{Et}_2\text{S}_2$	$\text{Co}_3(\text{CO})_6(\text{S})(\text{SR}) + \text{Co}_4(\text{CO})_5(\text{SR})_7$	170
PhSH or $\text{Ph}_2\text{S}_2$	$\text{Co}_3(\text{CO})_9\text{S} + \text{Co}_3(\text{CO})_4(\text{SPh})_5 +$ $\text{Co}_6(\text{CO})_{10}\text{S}(\text{SPh})_5$	171
S	$[\text{Co}_3(\text{CO})_7\text{S}]_2\text{S}_2, [\text{Co}_2(\text{CO})_5\text{S}]_2,$ $\text{Co}_3(\text{CO})_9\text{S}$	172
$\text{CS}_2$	$[\text{Co}_3(\text{CO})_9\text{C}]_2 + \text{Co}_3(\text{CO})_9\text{S} +$ $[\text{Co}_2(\text{CO})_5\text{S}]_2 + \text{Co}_3(\text{CO})_6\text{S}(\text{CS})^* +$ $\text{Co}_6(\text{CO})_{16}\text{C}_2\text{S}_3^{***}$	173
$\text{Co}(\text{EtS})_2 + \text{CO}$	$[\text{Co}_2(\text{CO})(\text{SEt})_2]_n$	174
$\text{Et}_2\text{S}_2$	$\text{Co}_6(\text{CO})_{11}\text{S}(\text{SR})_4^{**}$	175
EtSH	$[\text{Co}(\text{CO})_2\text{SEt}]_5$	176

\* Believed to be a thiocarbonyl derivative<sup>177</sup>

\*\* Originally<sup>170</sup> given the composition  $\text{Co}_4(\text{CO})_7(\text{SEt})_3$

\*\*\* Originally thought to be  $\text{Co}_4(\text{CO})_{10}\text{CS}_2$ <sup>173</sup>

The cyclopentadienyl cobalt dicarbonyl system has received much less attention than  $\text{Co}_2(\text{CO})_8$  itself. The halides  $\text{CpCo}(\text{CO})\text{X}_2$  ( $\text{X} = \text{Cl}$ ,<sup>178</sup>  $\text{I}$ <sup>179</sup>) are prepared by the action of halogens on the parent, but  $\text{R}_4\text{P}_2$  gives either total displacement of CO (when the product is  $[\text{CpCo}(\text{PR}_2)]_2$  or  $\text{X}$ <sup>180</sup>).



X

Dimethyl disulphide also causes total elimination of CO with formation of  $[\text{CpCoSMe}]_2$ .<sup>181</sup>

The range of carbonyl halides<sup>182</sup> and related complexes of Rh is very extensive, based either on octahedral co-ordination or square planar  $\text{Rh}(\text{I})$ , the latter compounds being readily involved in oxidation or addition reactions. Iridium also forms numerous halo-carbonyl derivatives, the products often depending on the reagents and exact reaction conditions; different oxidation states and co-ordination numbers occur and further reactions of the initial complex are also to be expected.<sup>13</sup> A review of these systems will not be

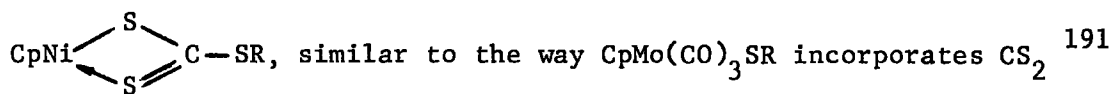
attempted since the factors involved are somewhat different from those under consideration in this thesis.

f) Nickel, Palladium and Platinum

Halogenonickel carbonyls are not known, although they are formed for the heavier congeners whose parent carbonyls  $M(CO)_4$  can not be made. 16 electrons produce the most stable grouping for Pt and Pd, the differences here probably arising from the electronic structures (Ni,  $d^8s^2$ ; Pd,  $d^{10}$ ; Pt,  $d^9s$ ) and promotional energies involved in formation of the zero and II oxidation states. Thus, it would appear that Ni(0) forms  $\pi$ -bonds more readily than Pd(0) or Pt(0), but that the reverse is the case for M(II). Interestingly all three compounds  $M(PF_3)_4$  are known, the Pt and Pd derivatives being less thermally stable than the Ni analogue,<sup>183,184</sup> and  $Pt(CO)(PPh_3)_3$  and similar compounds are known.<sup>185</sup> In addition, the larger size of the metal orbitals of Pt and Pd favours the formation of M-M bonds,<sup>186</sup> and the significance of this factor is substantiated by the stability of the polymeric platinum carbonyl  $[Pt(CO)_2]_n$ .<sup>185</sup>

The reaction between  $Ni(CO)_4$  and  $R_4P_2$  gives catenary compounds  $(CO)_3Ni(R_4P_2)Ni(CO)_3$ , which, on prolonged heating, is converted into  $[Ni(CO)_2(PR_2)]_2$  with bridging  $R_2P$  groups and a Ni-Ni bond.<sup>187</sup> The pseudohalide nature of  $R_2P^-$  is further exemplified by the u.v. or thermally initiated formation of the ions  $[Ni(CO)_3PR_2]^-$  and  $[Ni(CO)_2(PR_2)_2]^{2-}$  from  $Ni(CO)_4$  and  $KPR_2$ .<sup>188</sup>

The iodide  $\text{CpNi}(\text{CO})\text{I}$  was reported some years ago<sup>189</sup> and the mercaptide-bridged compound derived from it,  $[\text{CpNiSR}]_2$ , has been prepared.<sup>190</sup> This latter complex reacts with  $\text{CS}_2$  to give



to give  $\text{CpMo}(\text{CO})_2\text{S}_3\text{CR}$ .

In contrast to Ni, Pt forms series of both neutral and ionic halocarbonyl species, i.e.  $\text{Pt}(\text{CO})_2\text{X}_2$ ,  $[\text{Pt}(\text{CO})\text{X}]_2$ ,  $\text{Pt}_2(\text{CO})_3\text{X}_4$  and  $[\text{Pt}(\text{CO})\text{X}_3]^-$ .<sup>192</sup> Treatment of these (especially  $[\text{PtCl}_2(\text{CO})]_2$ ) with neutral ligands gives complexes of the type  $\text{Pt}(\text{CO})\text{LX}_2$ ,<sup>193-5</sup> which are also formed on carbonylation of platinum halide-base complexes.<sup>196-9</sup>

For Pd, only the yellow polymeric compounds  $[\text{Pd}_2(\text{CO})_2\text{Cl}]_n$ <sup>200</sup> and  $[\text{Pd}(\text{CO})\text{Cl}_2]_n$ <sup>201</sup> have been prepared. Attempts to replace the halide ligands by other anionic groups leads to total loss of CO, except in the case of  $\text{Pt}_2\text{S}(\text{CO})_2(\text{PPh}_3)_3$ , of unknown structure, which was prepared by pyrolysis of  $(\text{Ph}_3\text{P})_2\text{Pt}(\text{COS})$ .<sup>202</sup>

CHAPTER TWO

Iron Carbonyl Complexes Containing the Mercaptide Ligand

## 1. Introduction

In this chapter, attempts to prepare the unknown iron carbonyl mercaptides of stoichiometry  $\text{Fe}(\text{CO})_4(\text{SR})_2$  from iron carbonyl iodide,  $\text{Fe}(\text{CO})_4\text{I}_2$ , will be described. The parallel that has been shown in Chapter 1 to exist between the types of halo- and mercapto-carbonyl complexes would suggest that mercaptides of this type should exist since the halides are well known. However, the latter are thermally unstable with respect to loss of CO at room temperature, so the compounds  $\text{Fe}(\text{CO})_4(\text{SR})_2$  would be expected to dimerise or polymerise very easily by formation of sulphur bridges.

When this work was started, derivatives containing terminal SR groups were unusual, and most of the systematic trends in this area of carbonyl chemistry were published towards the end of this study. The known alkyl- or arylthioiron carbonyl complexes, together with their methods of preparation are shown in Table 2-1, where some of the features discussed in Chapter 1 are further illustrated. Metathetical reactions generally occur under mild conditions to yield complexes containing terminal RS groups. All the other reactions require vigorous conditions, or a highly reactive metal carbonyl as starting material. Thus, the more reactive  $\text{Fe}_3(\text{CO})_{12}$  is required for the preparation of good yields of  $[\text{Fe}(\text{CO})_3\text{SR}]_2$  under normal conditions whereas the more readily available, but less reactive



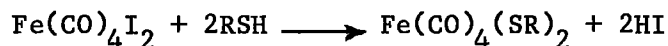
Table 2-1

Reactants		Conditions	Products	Ref.
Iron Carbonyl Compound	Organosulphur Compound			
$\text{Fe}_3(\text{CO})_{12}$	$\text{RSH}$ , $\text{R}_2\text{S}_2$ , $\text{R}_2\text{S}$	Heat alone or in solvent	$[\text{Fe}(\text{CO})_3\text{SR}]_2$	203
$\text{Fe}(\text{CO})_5$	$\text{EtSH}$	u.v.	$[\text{Fe}(\text{CO})_3\text{SEt}]_2$	203
$\text{Fe}(\text{CO})_5$	$\text{R}_2\text{S}_2$ or $\text{R}_2\text{S}$	Heat under CO pressure	$[\text{Fe}(\text{CO})_3\text{SR}]_2$	203
$\text{Fe}(\text{CO})_5$	$\text{R}_2\text{S}_2$	Autogenous Pressure ( $140^\circ$ )	$[\text{Fe}(\text{CO})_2(\text{SR})]_n$ mainly	203
$\text{Fe}_3(\text{CO})_{12}$	$\text{RSCN}$	Heat in benzene	$[\text{Fe}(\text{CO})_3\text{SR}]_2$ + $\text{Fe}_3(\text{CO})_9(\text{SR})_2\text{S}$ + other polymers	203
$\text{C}_3\text{F}_7\text{Fe}(\text{CO})_4\text{I}$	$\text{AgSCF}_3$	R.T. Benzene soln.	$[\text{C}_3\text{F}_7\text{Fe}(\text{CO})_3\text{SCF}_3]_2$	204
$[\text{CpFe}(\text{CO})_2]_2$	$\text{R}_2\text{S}_2$	Reflux in solvent	$[\text{CpFe}(\text{CO})\text{SR}]_2$	145
$[\text{CpFe}(\text{CO})_2]_2$	$\text{R}_2\text{S}_2$	u.v. Room temp.	$\text{CpFe}(\text{CO})_2\text{SR}$	145
$\text{CpFe}(\text{CO})_2\text{H}$	$\text{R}_2\text{S}_2$	Room temp.	$\text{CpFe}(\text{CO})_2\text{SR}$	145 205
$[\text{CpFe}(\text{CO})_2]_2$	$\text{C}_6\text{F}_5\text{SH}$	Heat	$\text{CpFe}(\text{CO})_2\text{SC}_6\text{F}_5$	206
$\text{CpFe}(\text{CO})_2\text{Br}$	$\text{NaSEt}$ or $\text{R}_3\text{SnSR}$	Ether, R.T.	$\text{CpFe}(\text{CO})_2\text{SEt}$	17 207
$\text{CpFe}(\text{CO})_2\text{SR}$	-	Heat or u.v.	$[\text{CpFe}(\text{CO})\text{SR}]_2$	17 208
$\text{CpFe}(\text{CO})_2\text{s.cs.SR}$	-	Heat	$[\text{CpFe}(\text{CO})\text{SR}]_2$	209

$\text{Fe}(\text{CO})_5$  gives little or no product under similar conditions unless unusual chelating organosulphur ligands such as bis(trifluoromethyl)-dithietene or 3,4-toluene dithiol are used.<sup>204</sup> It is therefore not surprising that no reactions between the extremely stable  $\text{Fe}_2(\text{CO})_9$  and thiols or disulphides have been reported, although this carbonyl is susceptible to photochemically initiated substitution, and this approach may be successful.

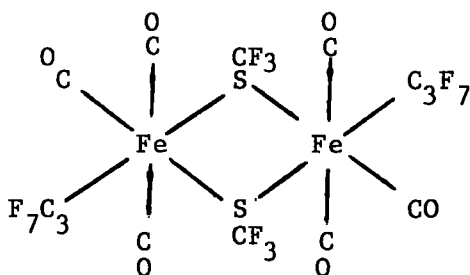
The general stability and predictable nature of the cyclopentadienyl iron carbonyl system discussed earlier is probably the reason why it has been so well studied (Table 2-1). Thus, the replacement of H or halogen by a terminal SR group proceeds smoothly at or just above room temperature, and the products are stable enough to be manipulated at room temperature. This suggests that the iron-halogen bond should be readily replaced in the system to be studied.

The possible route which will be described in this attempt to synthesise new iron carbonyl mercaptide complexes involves reactions of  $\text{Fe}(\text{CO})_4\text{I}_2$  and  $\text{Fe}(\text{CO})_2(\text{diphos})_2\text{I}_2$  with thiols in an attempt to liberate HI according to the equation



$\text{MgCO}_3$  was added to the reaction mixture in order to remove the HI as it was formed. The more normal use of an amine for this purpose is not applicable here because amines are known to react with

$\text{Fe}(\text{CO})_4\text{I}_2$ , usually to produce disubstituted derivatives  $\text{Fe}(\text{CO})_2\text{L}_2\text{I}_2$ .<sup>13</sup>  
 The use of carbonate in such reactions has the advantage that production of  $\text{CO}_2$  as the HI is consumed can easily be followed. The only reaction comparable with this within the iron carbonyl system is that between  $\text{C}_3\text{F}_7\text{Fe}(\text{CO})_4\text{I}$  and  $\text{AgSCF}_3$  in which the sulphur-bridged analogue of  $[\text{C}_3\text{F}_7\text{Fe}(\text{CO})_3\text{I}]_2$ , I, was obtained.<sup>204</sup>



I

## 2. Experimental

### a) Preliminary Reaction between $\text{MgCO}_3$ and $\text{PhSH}$ in ether

Thiophenol and  $\text{MgCO}_3$  were stirred together in ether solution to confirm that  $\text{CO}_2$  was not evolved. Indeed, there was no observed reaction over several hours, and since thiophenol is rather more acidic in nature than alkyl mercaptans<sup>210</sup> it was assumed that the other mercaptans used would not react either.

b) Preparation of Starting Materials

Fe(CO)<sub>4</sub>I<sub>2</sub>: This compound was prepared by the slow addition of a solution of I<sub>2</sub> in CHCl<sub>3</sub> to an equimolar quantity of Fe(CO)<sub>5</sub>, also in CHCl<sub>3</sub>. Vigorous evolution of CO occurred and crystals of the product formed on the sides of the reaction flask. When gas evolution ceased, the solid product was filtered and recrystallised from a CHCl<sub>3</sub>/hexane mixture. The black crystalline product is light sensitive, particularly in solution, so the compound was stored, and reactions performed in the dark.

$\nu(\text{C-O})$  in CHCl<sub>3</sub>; 2129(s), 2085(vs), 2063(s) cm<sup>-1</sup>

Lit.<sup>211</sup> 2131(s), 2086(vs), 2062(s).

Fe(CO)<sub>2</sub>(diphos)I<sub>2</sub>: Ph<sub>2</sub>PCH<sub>2</sub>.CH<sub>2</sub>PPh<sub>2</sub> (7.6 g., 20 mmole) in CHCl<sub>3</sub> was added dropwise to a solution of Fe(CO)<sub>4</sub>I<sub>2</sub> (8 g., 19 mmole) also in CHCl<sub>3</sub>. As the reactants mixed, a turbid brown orange appeared which soon went deep red and deposited the product. When CO evolution had ceased, the solvent was removed in vacuo, and the residue recrystallised from a CHCl<sub>3</sub>/hexane mixture as red-brown needles.

$\nu(\text{C-O})$ ; 2023(s) and 1984(s) cm<sup>-1</sup>

Found; C, 43.7; H, 3.31%. FeC<sub>28</sub>O<sub>2</sub>I<sub>2</sub>H<sub>24</sub>P<sub>2</sub> requires C, 43.9; H, 3.14%

c) Reactions with Thiophenol

In Chloroform solution: The carbonyl iodide (1 g., 2.4 mmole) and thiophenol (0.5 ml., 5 mmole) were stirred at 0°C in 30 ml. CHCl<sub>3</sub> for two hours. The infrared spectrum of a sample of the reaction solution

showed only C-O bands corresponding to  $\text{Fe}(\text{CO})_4\text{I}_2$ . The spectrum did not change over 24 hrs. Addition of  $\text{MgCO}_3$  did not initiate reaction, and the starting material was recovered unchanged after a further 24 hrs.

In Ether: The same quantities of reactants as above were stirred with excess  $\text{MgCO}_3$  in ether. Slow effervescence occurred and the evolved gases were shown to contain  $\text{CO}_2$ . The green brown reaction solution was filtered and the solvent removed under vacuum. The infrared spectrum of the crude product showed that no  $\text{Fe}(\text{CO})_4\text{I}_2$  remained; three new, strong C-O bands were observed at 2078, 2041, 2021  $\text{cm}^{-1}$ , together with numerous bands typical of PhS groups. This material decomposed rapidly in air and was light sensitive - in both cases a black residue was obtained which contained some free  $\text{I}_2$  (purple petroleum ether solution and purple vapour on warming) but no CO groups (IR). The crude product could not be recrystallised from ether,  $\text{CH}_2\text{Cl}_2$  or  $\text{CHCl}_3$ , in which it is soluble, nor from mixtures of these with hexane or petroleum ether. Inconsistent analytical figures were obtained for different samples. Attempted sublimation at  $10^{-3}$  mm gave no coloured sublimate up to  $180^\circ$ . At this temperature, a white crystalline solid, which was shown by infrared spectroscopy and melting point ( $60^\circ$ ) to be diphenyldisulphide, collected on the cold-finger. Since this will sublime at a much lower temperature than  $180^\circ$  (i.e. at  $\sim 60-70^\circ$ ) this observation suggests that the carbonyl complex contains PhS groups which form  $\text{Ph}_2\text{S}_2$

on decomposition.

This product could not be characterised because of its light and thermal instability at room temperature, but it was shown to contain PhS, I and CO groups.

One one occasion the exact molar quantity of  $\text{MgCO}_3$  was used, rather than an excess, and surprisingly a different product was obtained. The CO bands in this case were at 2094, 2059 and  $2050 \text{ cm}^{-1}$ ; i.e. about half-way between the carbonyl bands of  $\text{Fe}(\text{CO})_4\text{I}_2$  and the product prepared using excess  $\text{MgCO}_3$ . This compound was also air and light sensitive (decomposing in air totally in  $\sim 60$  hrs.), and purification attempts were unsuccessful, but it was shown to contain iodine and phenylmercapto-groups.

Thus, at least two compounds were prepared in this reaction; both contain CO, SPh and I groups, but could not be characterised. Since loss of CO appeared to be the primary decomposition mechanism, attempts were made to stabilise the product by use of the bidentate ligands bis(diphenylphosphino)ethane (Diphos) and 2,2'-bipyridyl (Bipy) and to prepare a more stable complex directly by use of  $\text{Fe}(\text{CO})_2(\text{diphos})\text{I}_2$ .

Attempted Stabilisation using 2,2'-Bipyridyl:

The reaction between  $\text{Fe}(\text{CO})_4\text{I}_2$  (3 g.), PhSH (1.5 ml.) and excess  $\text{MgCO}_3$  was performed as above. When the gas evolution ceased, the ether and excess thiol were removed in vacuo, the residue was dissolved in  $\text{CHCl}_3$  (30 ml.) and the deep-brown solution filtered. Dropwise

addition of bipy (1 g.) in  $\text{CHCl}_3$  caused immediate precipitation of a red solid. The remaining solution (brown in colour) contained a mixture of several carbonyl compounds (Infrared) but in small amounts, thereby precluding their isolation and characterisation.

The red solid was shown to be a bipyridyl-iron(II) iodide by recrystallisation from hot water as  $\text{Fe}(\text{bipy})_3\text{I}_2 \cdot 6\text{H}_2\text{O}$ .

(Found; C, 40.8; H, 3.74%.  $\text{FeC}_{24}\text{N}_6\text{H}_{30}\text{I}_2\text{O}_6$  requires C, 40.7; H, 4.0%)

The presence of iodine was proved by chemical tests, and the absence of SPh and CO groups was shown by infrared spectroscopy.

Attempted Stabilisation using 1,2-bis(diphenylphosphino)ethane:

The initial reaction and extraction of the product was carried out as above. On the addition of the diphosphine in ether/ $\text{CHCl}_3$  solution immediate precipitation of a yellow-brown non-carbonyl occurred. This was not investigated further. The remaining red solution contained a dicarbonyl complex, but in insufficient quantity for identification.

Reaction between  $\text{Fe}(\text{CO})_2(\text{diphos})\text{I}_2$  and PhSH:

No new carbonyl-containing product was produced under any of the following conditions.

- 1) Refluxing  $\text{CH}_2\text{Cl}_2$  for 24 hrs.
- 2) Refluxing ether for eight hours with  $\text{MgCO}_3$
- 3) In THF at room temperature for 8 hrs. with  $\text{MgCO}_3$ .

In refluxing THF, the carbonyl decomposed to a yellow non-carbonyl solid which contained both the phosphine ligand and SPh groups, but it was not investigated further.

d) Reactions with Isopropylmercaptan

This reaction was performed several times using either different quantities of reactants or different solvents. Again, it was found that the presence of  $\text{MgCO}_3$  in the reaction mixture was necessary, and that no significant reaction occurred below room temperature. The following procedure, using excess thiol in ether solution was found to be the most satisfactory.

A double Schlenk-tube containing  $\text{Fe}(\text{CO})_4\text{I}_2$  (10 g., 24 mmoles)  $\text{MgCO}_3$  (10 g.) and diethyl ether (50 ml.) in one arm was attached to the vacuum line and the contents degassed. Isopropylthiol (7 ml.) was then condensed into the vessel under vacuum, and the mixture allowed to warm to room temperature, with stirring, under  $\text{N}_2$ . Evolution of a gas (which contained some  $\text{CO}_2$ ) occurred, accompanied by a darkening of the solution from red-brown to almost black in colour. After 3 hrs., the solvent was removed under vacuum and the residue pumped ( $10^{-3}$  mm) until the small amount of free  $\text{I}_2$  had sublimed out. Hexane (3 x 50 ml.) was then added and the dark-red solution filtered into the other arm, where it was cooled to  $-78^\circ$  to yield a red solid. This usually contained  $\sim 10\%$   $[\text{Fe}(\text{CO})_3\text{SR}]_2$  but recrystallisation from hexane at  $-78^\circ$  gave the pure red product which, on the basis of the following information is thought to have the constitution  $\text{Fe}_2(\text{CO})_5(\text{Spr}^i)_3\text{I}$ .

Yield 1.1 g. (15%)

The residue left after extraction consisted of an unidentified,



non-carbonyl iron complexes which contain iodine and  $\text{SPr}^{\text{i}}$  groups, but attempts to isolate and characterise them were unsuccessful.

### Properties

The complex decomposes slowly (2-3 days) as a solid, but more rapidly (a few hours) in solution at room temperature under  $\text{N}_2$  in the dark. When exposed to daylight or the air total decomposition occurs rapidly (minutes). The non-carbonyl residue of decomposition contains  $\text{SPr}^{\text{i}}$  groups as shown by infrared spectroscopy, and free  $\text{I}_2$  is also produced in the decomposition (recognised by volatility, solution properties and chemical tests). Fortunately the residue is insoluble, so the complex can be separated before being recrystallised before each use by recrystallisation. It decomposes instantaneously in concentrated acids, and purple vapours of  $\text{I}_2$  are generated by warm conc. sulphuric acid. In a sublimation apparatus, there is extensive decomposition, but a little of the complex sublimes at  $\sim 70^\circ$ , but another carbonyl complex is also collected on the cold finger. The new bands (2062, 2038, 2018 and  $2006 \text{ cm}^{-1}$ ) do not correspond to  $[\text{Fe}(\text{CO})_3\text{SPr}^{\text{i}}]_2$ .

### Infrared spectrum:

The C-O stretching bands, shown in Table 2-2, illustrate the changes that occur in the spectra of carbonyl complexes in different conditions.

Table 2-2C-O stretching bands of  $\text{Fe}_2(\text{CO})_5(\text{SPr}^i)_3\text{I}$  ( $\text{cm}^{-1}$ )

Nujol Mull	2088(s), 2082(sh), 2045(sh), 2037(s), 2025(s), 2010(vw), 1993(s)		
$\text{CHCl}_3$ soln.	2085(s)	2032(s,br)	1998(m)
Cyclo- hexane soln.	2081(s)	2035(s), 2028(s)	2000(s)

There are also bands characteristic of the  $\text{SPr}^i$  group<sup>212</sup> at 1667(w), 1466(s), 1381(s), 1263(m), 1235(m), 1149(m), 1087(m) and 800(br,s).

Other bands, probably M-C-O bending and/or M-C stretching modes occur at 605(s), 581(m), 562(s) and 524(m).

P.M.R. Spectrum:

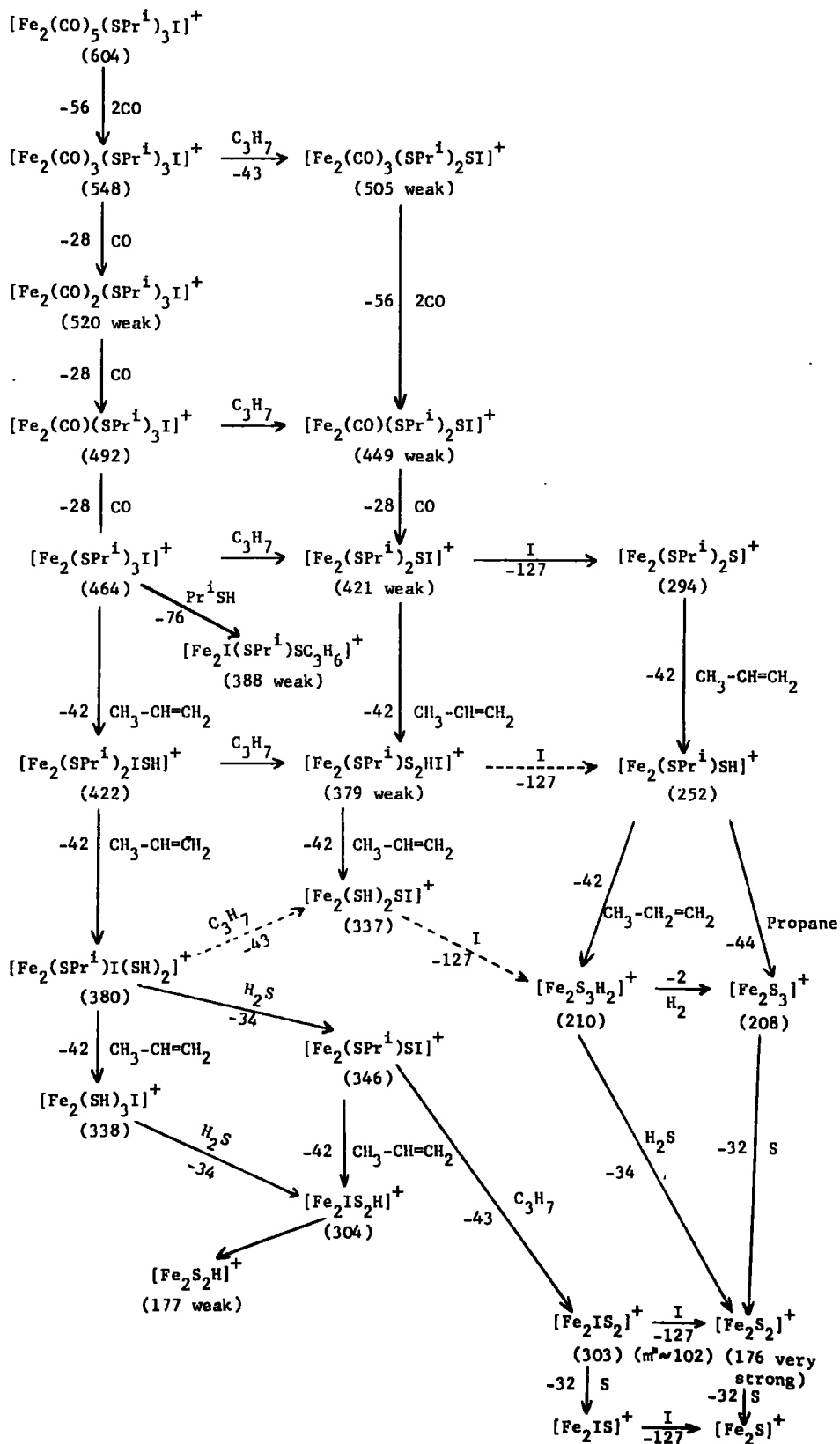
An unsatisfactory spectrum in  $\text{CCl}_4$  solution was obtained because the complex decomposed substantially in the instrument causing inhomogeneity of the sample, but two broad unresolved peaks in the positions expected for an isopropyl group were observed (i.e. CH at 6.8-7 $\gamma$  and  $\text{CH}_3$  at 8.6-8.7 $\gamma$ ). They are in the intensity ratio 1:6.

Mass Spectrum:

The complex had to be recrystallised several times to remove traces of  $[\text{Fe}(\text{CO})_3\text{SPr}^i]_2$  before a spectrum was obtained which was not confused by the spectrum of this material. Then, a parent ion at 605 units, and a breakdown pattern (Fig.2-1) corresponding to the

Fig. 2-1

Breakdown Scheme for  $[\text{Fe}_2(\text{CO})_5(\text{SPr}^i)_3\text{I}]^+$



formulation  $\text{Fe}_2(\text{CO})_5(\text{SPr}^i)_3\text{I}$  was obtained. The following are interesting features in this mass spectrum.

(i) The most notable is the loss of the isopropyl radical as well as CO groups from the ions  $[\text{Fe}_2(\text{CO})_3(\text{SPr}^i)_3\text{I}]^+$  and  $[\text{Fe}_2(\text{CO})(\text{SPr}^i)_3\text{I}]^+$ . It is very unusual for metal carbonyl derivatives to lose any fragments before all the CO groups have been removed.<sup>213-215</sup>

(ii) The absence of an ion corresponding to  $[\text{Fe}_2(\text{CO})_4(\text{SPr}^i)_3\text{I}]^+$  is not unusual; many carbonyl complexes, especially when they contain organic groups lose two CO groups simultaneously, so the highest observed masses correspond to  $\text{P}^+$  and  $(\text{P}-2\text{CO})^+$ .<sup>216</sup>

(iii) The breakdown of branched-chain aliphatic groups by loss of olefins is typical, and has been observed for both main-group inorganic compounds and transition metal complexes.<sup>216</sup> Thus, the many observed losses of propene confirms that the precursor in each case is an isopropyl group.

(iv) The very early loss of an iodine atom in the breakdown scheme probably indicates that this ligand is bound terminally, whereas the S atoms tend to be the last to be lost, suggesting that these are probably bridging. (cf.  $[\text{Fe}(\text{CO})_3\text{SR}]_2$  species whose  $\text{Fe}_2\text{S}_2$  nucleus remains intact until all peripheral groups have been lost).

#### Molecular Weight:

Consistent values could not be obtained osmometrically in  $\text{CHCl}_3$  because of decomposition, and the complex was insufficiently soluble

to allow a measurement to be made cryoscopically.

### Analytical Data

Analytical figures consistent with the formulation suggested by the mass spectrum could not be obtained because of the loss of CO from the sample even in the solid state at room temperature. The values shown in Table 2-3 were all obtained on freshly recrystallised samples which were maintained at  $-78^{\circ}$  until they were put into a glove box for weighing. Calculated values for  $\text{Fe}_2(\text{CO})_n(\text{SPr}^i)_3\text{I}$  ( $n = 2-5$ ) are also included in the Table for comparison.

Table 2-3

	%C	%H	%CO	%Fe
measured values	26.6 <sup>a</sup>	3.77 <sup>a</sup>	17.4 <sup>a</sup>	19.9 <sup>c</sup>
	27.0 <sup>b</sup>	3.83 <sup>b</sup>	16.1 <sup>c</sup>	20.1 <sup>c</sup>
$\text{Fe}(\text{CO})_5(\text{SPr}^i)_3\text{I}$	27.8	3.48	23.2	18.6
" $(\text{CO})_4$ "	27.1	3.65	19.4	19.5
" $(\text{CO})_3$ "	26.2	3.83	15.3	20.4
" $(\text{CO})_2$ "	25.4	4.04	10.8	21.4

a, b and c were all different samples

All the measurements were conducted after the complex had been in the the glove box at room-temperature for  $\sim 1\frac{1}{2}$  hrs. during which time it is known to lose CO. Thus, although the other figures do not vary sufficiently to allow any conclusion to be made about the exact

constitution of the complex as measured, the CO content, which varies much more, shows clearly that the complex analysed as  $\text{Fe}_2(\text{CO})_{3-4}(\text{SPr}^i)_3\text{I}$ . The measured C, H and Fe percentages all are consistent with this. It was therefore concluded that the complex has the stoichiometry  $\text{Fe}_2(\text{CO})_5(\text{SPr}^i)_3\text{I}$ , as indicated by the mass spectrum, but that between one and two molecules of CO are lost during the period it was in the glove-box.

#### Attempted Stabilisation by Triphenylarsine

Since all the evidence above indicates that the complex under investigation decomposes by rapid loss of probably two CO groups, and then by the slower loss of the other CO groups, an attempt was made to stabilise the complex by substitution of the more reactive CO groups with  $\text{Ph}_3\text{As}$ .

The initial reaction of  $\text{Fe}(\text{CO})_4\text{I}_2$  and  $\text{Pr}^i\text{SH}$  was performed, as above, on a 6 mmole scale, and the product extracted into 40 ml. cyclohexane.  $\text{Ph}_3\text{As}$ , also in cyclohexane was added slowly at room temperature. CO evolution was observed, together with the immediate formation of a precipitate. Infrared spectra of the solution in the CO region were recorded at intervals as the arsine was added, but only the bands associated with the initial complex were observed. Eventually the CO disappeared totally from the spectrum, so the addition of arsine was stopped and the precipitate filtered off. It was dissolved in  $\text{CHCl}_3$  and reprecipitated as a yellow powder by the

addition of hexane, but the infrared spectrum showed it to be a non-carbonyl. Various analytical data (C and H) were obtained on the products of attempted recrystallisations. Thus, mixtures were obtained which could not be separated, and it was concluded that the carbonyl groups were too labile for the complex to be stabilised by the use of a neutral ligand.

### 3. Discussion

These results show that a reaction takes place between iron tetracarbonyl iodide and thiols in donor solvents such as ether, but not in  $\text{CHCl}_3$ . Elimination of  $\text{CO}_2$  from  $\text{MgCO}_3$  confirms that the reactions proceed by elimination of HI. However the reactions are not the simple stoichiometric replacement of halide by mercaptide as anticipated because both I and RS groups can be detected in the highly reactive carbonyl-containing products.

Similar products have been reported before. The compounds  $[\text{Fe}(\text{CO})_3\text{SR}]_2$ , with HCl and with  $\text{I}_2$  in pyridine undergo complete CO elimination,<sup>217</sup> but from their reaction with  $\text{I}_2$  and  $\text{Br}_2$  in dichloromethane, King<sup>218</sup> was able to isolate brown and orange solids respectively which are described as "complex CO-, halogen- and RS-containing products which could not be identified". Since this work was completed, Abel et al.<sup>207</sup> have mentioned their unpublished results of the reactions between  $\text{Fe}(\text{CO})_4\text{I}_2$  and organotin thiolates ( $\text{R}_3\text{Sn-SR}'$ ),

from which similar, also unidentified complexes were obtained.

It is unusual that two apparently quite different complexes are produced when PhSH and  $\text{Pr}^i\text{SH}$  are used. The difference in the compounds is shown very clearly by their infrared spectra (Fig.2-2), which also show, in addition, the differences in spectra when they are recorded in solution and as mulls. There was also no indication that  $[\text{Fe}(\text{CO})_3\text{SPh}]_2$  was produced in the reaction with PhSH - this is a further difference between this and the reaction with isopropyl thiol.

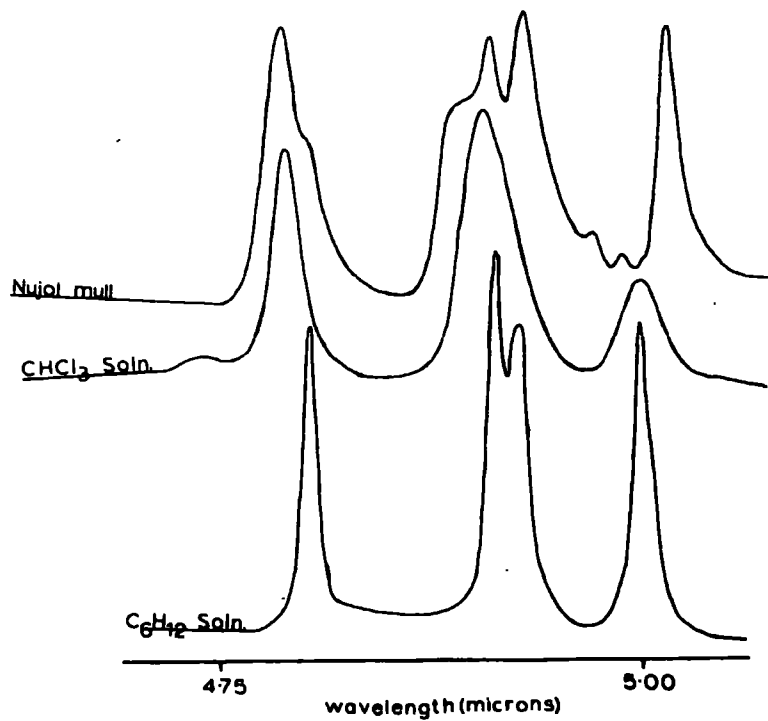
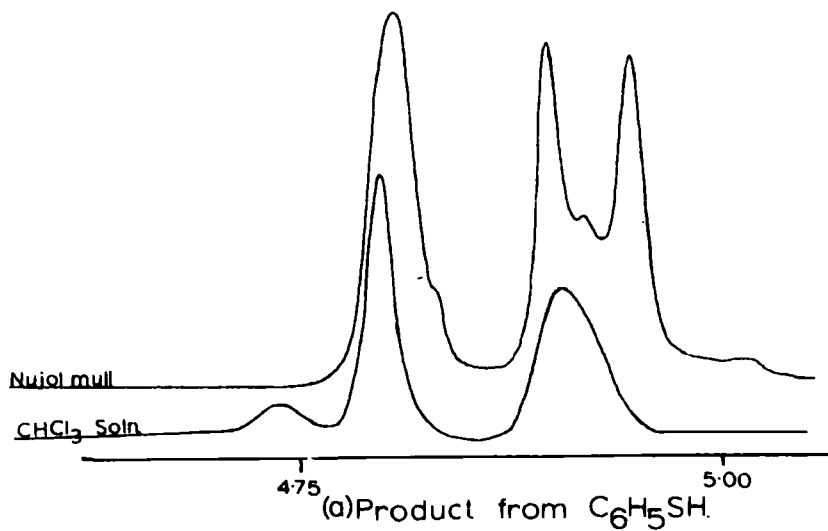
The spectrum of the thiophenol product (Fig.5-2a) is very much simpler than that of  $\text{Fe}_2(\text{CO})_5(\text{SPR}^i)_3\text{I}$  (Fig.5-2b), suggestive of higher molecular symmetry. In fact, the band intensities and separations are very similar to those observed for  $\text{Fe}(\text{CO})_4\text{I}_2$  and may be an indication that  $\text{Fe}(\text{CO})_4(\text{SPh})_2$  was present, although the iodine in the product is not consistent with this suggestion. The spectrum is probably most consistent with a cis tri- or tetra-carbonyl species, although other possibilities cannot be discounted in the absence of any definitive data.

The isopropyl derivative was difficult to characterise because of its thermal instability, but all the results are consistent with the formulation  $\text{Fe}_2(\text{CO})_5(\text{SPR}^i)_3\text{I}$ . As described earlier, the mass spectrum suggests that the  $\text{SPR}^i$  groups are bridging, whereas the Iodine ligand is terminally bound, and this would fit into the general pattern

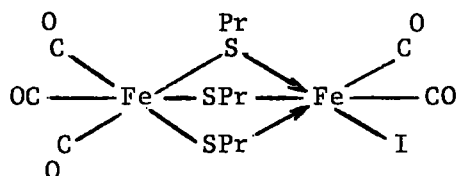


FIG.2-2

C—O Bands in the infrared spectra of organo-  
sulphur derivatives of  $\text{Fe}(\text{CO})_4\frac{1}{2}$



discussed in Chapter 1. The iodide ligand has a low bridging tendency - the two halves of  $\text{Fe}_2(\text{CO})_8\text{I}_2$ , for example, being held together only by an Fe-Fe bond, with the iodide ligands not bridging - whereas alkylthio groups are very good bridging ligands. A possible structure, then, is II which can be thought of as isostructural with  $\text{Fe}_2(\text{CO})_9$ , being based on octahedrally co-ordinated iron.



II

Both iron atoms are in a formal oxidation state of +2, and conform to the inert gas rule without the presence of any direct Fe-Fe bonding. This structure would have  $C_1$  symmetry, for which five infrared active C-O stretching modes would be expected. However the observation of only four bands does not preclude this structure from consideration, because one may be of weak intensity, or two may accidentally coincide.

#### 4. Conclusion

The reactions of  $\text{Fe}(\text{CO})_4\text{I}_2$  with thiols failed to produce complexes containing terminal SR groups, although new carbonyl mercaptide complexes of interesting and unusual composition have been made.

Publication of research along identical lines from the Universities of Bristol and Strathclyde in advance of my own work encouraged a change of emphasis in my research, and after the hydride work to be described in the next chapter was completed, effort was transferred to anionic groups containing nitrogen in a non-aromatic  $\pi$ -system, as will be described in Chapters 4 and 5.

CHAPTER THREE

Some Aspects of the Chemistry of Iron tetracarbonyldihydride

## 1. Introduction

In this chapter, the reactions of  $\text{Fe}(\text{CO})_4\text{H}_2$  with mercaptans, triphenylphosphine and triphenylarsine are described. As outlined in Chapter 1, the carbonyl hydrides are reactive even at comparatively low temperatures, and are therefore good starting materials from which to prepare the rather unstable metal carbonyl mercaptides in which the RS group is terminally bound. This approach has been reported for carbonylmonohydrides,<sup>103,32</sup> but not for dihydrides. This study was therefore initiated in order to investigate the general nature of the hydride reaction as it applies to  $\text{Fe}(\text{CO})_4\text{H}_2$ , with the aim of preparing either complexes of the type  $\text{Fe}(\text{CO})_4(\text{SR})_2$ , or a series of sulphur bridged complexes formed by CO evolution and polymerisation of this species. The two types of complexes most likely to be formed in this reaction are  $[\text{Fe}(\text{CO})_3\text{SR}]_2$  or  $[\text{Fe}(\text{CO})_2(\text{SR})_2]_n$ , the latter having only been prepared in an autoclave.<sup>218</sup>

The reactions of this hydride with  $\text{Ph}_3\text{P}$  and  $\text{Ph}_3\text{As}$  were also studied, originally in an attempt to prepare the unknown ligand-substituted iron carbonyl hydrides, which should be more amenable to study than the parent hydride because of their presumed greater stability to heat and oxidation. Some phosphine substituted carbonyl hydrides of manganese, cobalt and osmium have been prepared for similar reasons and in all cases, substantially greater thermal stability

is conferred on the hydride by the presence of the ligand, as shown in Table 3-1.

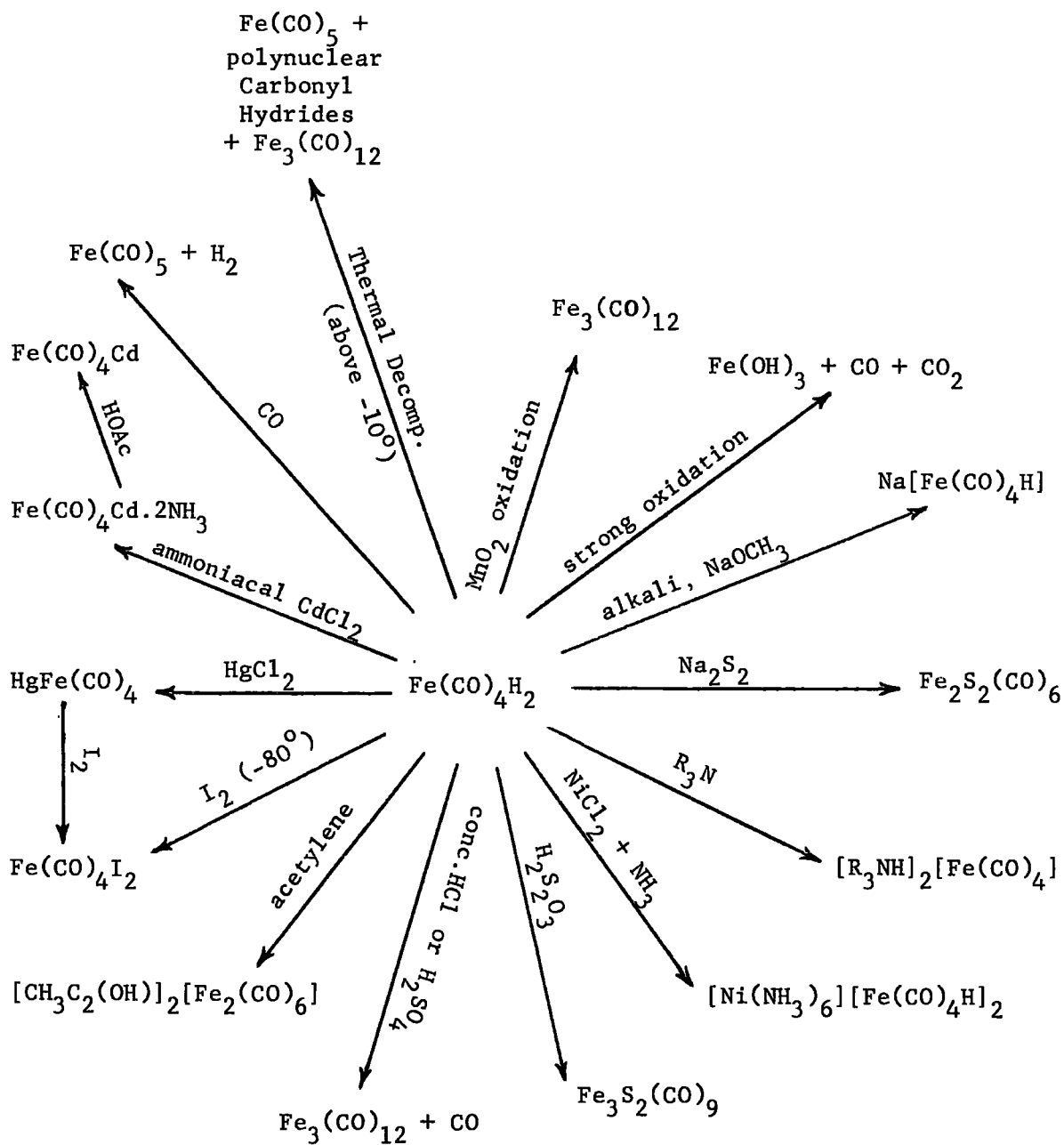
Table 3-1

Compound	Colour	Melting Point	Ref.
$\text{HMn}(\text{CO})_5$	Colourless	-24.6	219
$\text{HMn}(\text{CO})_4\text{PPh}_3$	Pale Yellow	70	220
$\text{HCo}(\text{CO})_4$	Yellow	-26	221
$\text{HCo}(\text{CO})_3\text{PPh}_3$	Yellow	70	222
$\text{HCo}(\text{CO})_3\text{P}(\text{OPh})_3$	Dark Yellow	0	222
$\text{HCo}(\text{CO})_2(\text{P}(\text{OPh})_3)_2$	Colourless	88	222
$\text{H}_2\text{Os}(\text{CO})_4$	Colourless	< 0	223
$\text{H}_2\text{Os}(\text{CO})_3\text{PPh}_3$	Colourless	148	223

Certain aspects of the chemistry of  $\text{Fe}(\text{CO})_4\text{H}_2$  have been investigated, the large majority concerning its acidic nature in aqueous solution and its disproportionation into salts or polynuclear species under different conditions.<sup>224</sup> These reactions, together with some others are summarised in Fig.3-1.

Attempts to replace the hydrogen by  $\sigma$ -bonded alkyl groups using diazomethane, Grignard reagents or the addition of olefins have been unsuccessful, although the corresponding perfluoroalkyltetracarbonyl-iron complexes are known.<sup>225</sup>

Fig. 3-1  
Reactions of  $\text{Fe}(\text{CO})_4\text{H}_2$



Several of the reactions shown in Fig.3-1 illustrate the ease with which the hydrogen atoms of  $\text{Fe}(\text{CO})_4\text{H}_2$  are either lost as  $\text{H}_2$ , or become involved in the reaction, usually protonating a Lewis base. However, the greater  $\sigma$ -donor and poorer  $\pi$ -acceptor properties of  $\text{Ph}_3\text{P}$  and  $\text{Ph}_3\text{As}$  ligands compared with CO should stabilise the Fe-H bonds; i.e. in this molecule these bonds are probably best considered to be polarised  $\text{Fe}-\overset{\delta-}{\text{H}}-\overset{\delta+}{\text{H}}$  in order to account for their acidity and so the bonding characteristics of these ligands should depolarise the Fe-H bond. Table 3-2 shows that the replacement of a CO group by  $\text{PPh}_3$  does greatly reduce the acidity of this type of hydride. It should be mentioned however that theoretical calculations of the high-field proton resonance shifts suggest that for all transition metal-hydrogen bonds, the H atom bears a partial negative charge.<sup>294</sup>

Table 3-2

Compound	Dissociation Constant	Ref.
$\text{HCo}(\text{CO})_4$	$\sim 1$ (Strong Acid)	222
$\text{HCo}(\text{CO})_3\text{PPh}_3$	$1.1 \times 10^{-7}$	226
$\text{HV}(\text{CO})_6$	Strong Acid	227
$\text{HV}(\text{CO})_5\text{PPh}_3$	$1.5 \times 10^{-7}$	227



## 2. Preparation of $\text{Fe}(\text{CO})_4\text{H}_2$

KOH (10 g.) and  $\text{Ba}(\text{OH})_2$  (13 g.) were stirred with water (60 ml.) and  $\text{Fe}(\text{CO})_5$  (10 ml.) until no carbonyl remained (it can be detected in the mixture by its tendency to form an oil surface on the solution). The orange solution was filtered from the white, flocculent precipitate of  $\text{BaCO}_3$  into a 1 l. three-necked flask which was equipped with a dropping funnel and  $\text{N}_2$  inlet. The flask was then connected to a vacuum line via a splash head (essential) and drying tubes containing  $\text{CaCl}_2$  and  $\text{P}_2\text{O}_5$ . The whole system was then evacuated and  $2\text{NH}_2\text{SO}_4$  (90 ml.) was added dropwise over about three hours. The solution rapidly went deep red and vigorous gas evolution occurred. The gases produced (a mixture of  $\text{Fe}(\text{CO})_4\text{H}_2$ ,  $\text{CO}_2$  and a little water vapour) were collected in a trap at  $-196^\circ$ . When the reaction had ceased, the flask and drying tubes were removed and the contents of the trap pumped ( $10^{-3}$  mm) while immersed in bath at  $-96^\circ$  (toluene) until all the  $\text{CO}_2$  had sublimed out (2-3 hrs. on average -  $\text{CO}_2$  has a pressure of 157.3 mm at  $-96^\circ$ ). This procedure left  $\text{Fe}(\text{CO})_4\text{H}_2$  (5-8 ml. typically) in the trap as a white or pale-yellow solid which was stored under  $\text{N}_2$  at  $-196^\circ$ .

When the hydride was required, the trap was allowed to warm to  $-36^\circ$  ( $\text{C}_2\text{H}_4\text{Cl}_2$  bath) and the hydride was pumped into a reaction vessel immersed in liquid nitrogen. It was found that this procedure led to less decomposition of the hydride than a normal vacuum transfer under

a static vacuum. The quantity used for a particular reaction was not measured because of its thermal instability. Instead, the quantity was estimated by comparing the volume collected with water in a similar vessel. The hydride becomes more stable, thermally, in hydrocarbon solvents; such solutions decomposing only slowly (several hours) at  $0^{\circ}\text{C}$ , at which temperature the pure hydride rapidly decomposes. All reactions involving this compound have to be performed with the strictest exclusion of oxygen.

### 3. Reaction between $\text{Fe}(\text{CO})_4\text{H}_2$ and Mercaptans

#### a) Reaction with $\text{C}_6\text{H}_5\text{SH}$ and $\text{C}_6\text{F}_5\text{SH}$

In each case, excess thiol in a reaction flask was degassed on the vacuum line and then cooled to  $-196^{\circ}$  while the system was evacuated. The carbonyl hydride was then condensed into the flask and the mixture allowed to warm up slowly. In each case the mixture started to go red at  $\sim 0^{\circ}\text{C}$ , so the mixture was maintained in an ice bath until gas evolution ceased (several hours). The infrared spectrum of the gas showed that it contained CO and the mass spectrum confirmed that it was a mixture of CO and  $\text{H}_2$ .

The bright red crystals produced during the reaction were filtered, washed with hexane and pumped dry. A little hexane was added to the filtrate and, on cooling to  $-40^{\circ}$ , a further crop of red crystals was obtained. The product in both cases was  $[\text{Fe}(\text{CO})_3\text{SR}]_2$ ,

as shown by infrared and mass spectroscopy, and, for the phenyl derivative, by analysis. Obtained: C, 43.6; H, 2.12%;  $\text{Fe}_2\text{C}_{18}\text{H}_{10}\text{O}_6\text{S}_2$  requires; C, 43.4; H, 2.00%.

When the same reactions were carried out in hexane solution, reaction did not start till  $\sim 10^\circ$ , when the same products were obtained. In no case was there any evidence that any other compound was formed in the reaction.

b) Reaction with Isopropylthiol

This reaction was conducted as described above, except that it is rather more rapid at  $0^\circ\text{C}$  ( $\sim 3-4$  hrs. for completion). The excess thiol was then removed in vacuo and the brown residue recrystallised by cooling a pentane solution to  $-78^\circ$ . The deep red crystalline product was shown to be  $[\text{Fe}(\text{CO})_3\text{SPr}^i]_2$  by infrared and mass spectroscopy. Obtained C, 36.7; H, 3.75%;  $\text{Fe}_2\text{C}_{12}\text{H}_{14}\text{O}_6\text{S}_2$  requires C, 37.0; H, 3.66%. The same product was obtained when the reactants were used in 1:1 molar proportions.

When the reaction between  $\text{Fe}(\text{CO})_4\text{H}_2$  and  $i\text{-C}_3\text{H}_7\text{SH}$  was stopped in its initial stages by freezing the mixture to  $-196^\circ$ , the gases produced were shown by mass spectroscopy to be a mixture of CO and  $\text{H}_2$ . These gases were removed before repeating the process after a few more minutes of reaction, and again both CO and  $\text{H}_2$  had been produced. It

was therefore concluded that any intermediate species formed by elimination of  $H_2$  was immediately rearranging or further reacting to form the dimeric product with loss of CO, i.e.  $[Fe(CO)_3SR]_2$  was being formed under very mild conditions. A similar reaction with the acidic  $C_6F_5OH$  was therefore conducted in an attempt to prepare an analogous, unknown oxygen-bridged complex.

c) Reaction with Perfluorophenol

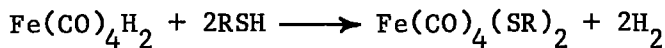
This reaction was performed in toluene solution in the same way as those above. Reaction started at  $0^\circ C$ ; CO and  $H_2$  were evolved and the solution became grey-black. However, the only isolable carbonyl complex was  $Fe_3(CO)_{12}$ , which was extracted and crystallised from  $CH_2Cl_2$ , suggesting that oxidation of the hydride had occurred.

d) Discussion

All the published methods<sup>228-237</sup> for the preparation of the sulphur-bridged complexes  $[Fe(CO)_3SR]_2$  require high temperatures (often refluxing benzene) and the yields vary between 10 and 90%. Several by products are also formed in some of these reactions. Use of  $Fe(CO)_4H_2$  as the starting material, however, gives an essentially quantitative yield of pure  $[Fe(CO)_3SR]_2$  under very mild conditions, illustrating further the high reactivity of the hydride compared with even  $Fe_3(CO)_{12}$ .

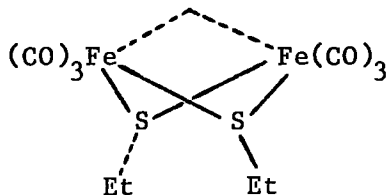
The observation that this complex is formed when the reactants are used in a 1:1 molar ratio probably indicates that the expected

reaction



was not occurring, or that the product was reacting further with the hydride present - the ease with which molecular  $\text{H}_2$  is lost from this carbonyl hydride probably being the most important factor.

The dimeric nature of the products of all these reactions was first suspected in 1960,<sup>239</sup> and was confirmed by an X-ray analysis of the ethyl derivative,<sup>19</sup> in which the ethyl groups were found to be in an "anti" conformation (I)



I

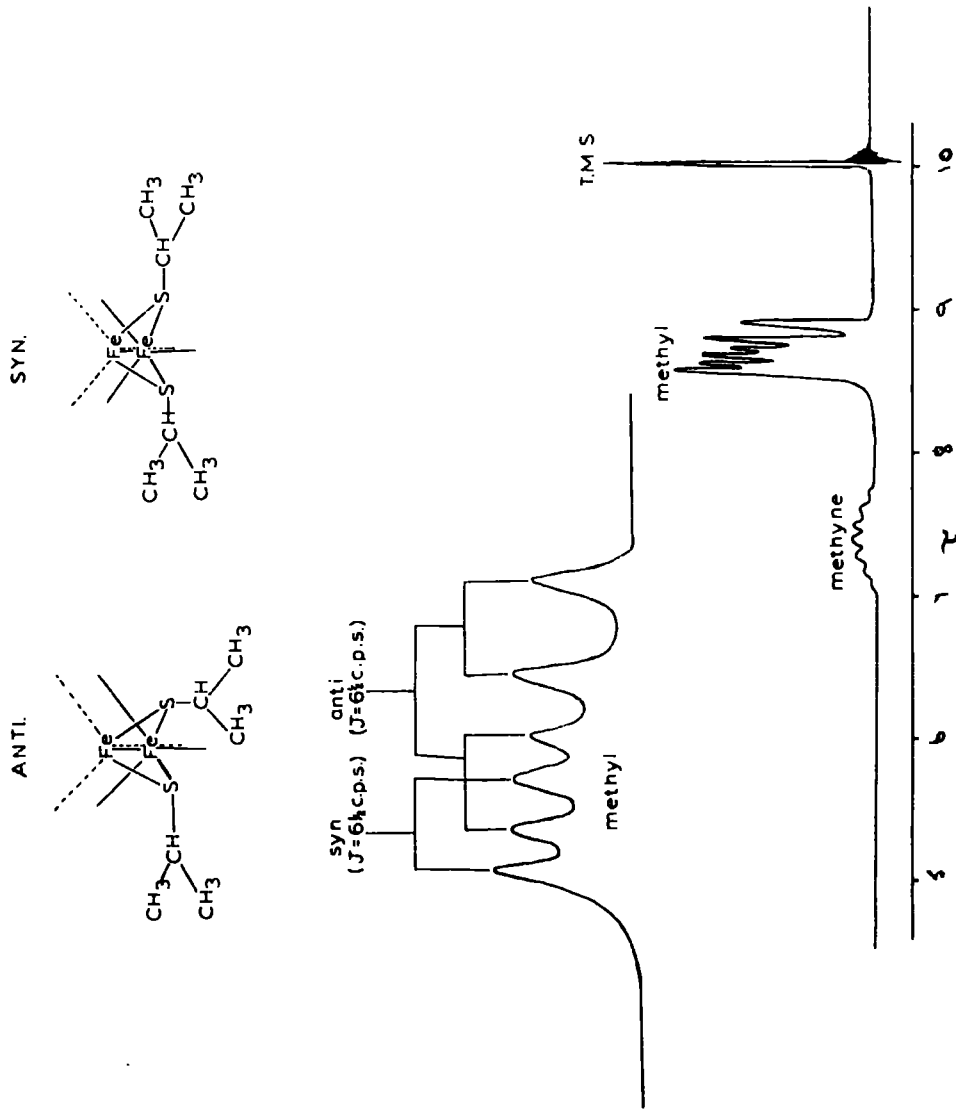
The p.m.r. spectra of these complexes have been interpreted as showing that both the "syn" and "anti" forms can occur<sup>233,237</sup> - facile inversion of the pure isomers to an equilibrium mixture occurring quite rapidly in solution<sup>240</sup> for the methyl and ethyl derivatives. The phenyl and t-butyl complexes on the other hand exist only in the "anti" form, with non-equivalent organic groups, presumably because of steric hindrance.

The p.m.r. spectrum of the isopropyl compound which has not been reported before, shows that this complex fits into this general pattern. Whether made by published methods<sup>232</sup> or via  $\text{Fe}(\text{CO})_4\text{H}_2$ , the product is a mixture of isomers, but the "anti" form predominates (62% to 38%). The spectrum and diagrams of the two isomeric structures are shown in Fig.3-2. The resolved septuplet ( $\tau = 7.41$ ,  $J = 6$  c.p.s.) produced by the isopropylmethyne proton coupling with six adjacent protons is not sufficiently strong to show fine structure, so it only shows that the CH groups are in a similar environment in both forms. The three doublets ( $J = 6.5$  c.p.s. in each case) arise from the methyl groups as follows. In the "syn" isomer the methyl groups are in identical environments, so only a single doublet occurs ( $\tau = 8.64$ ), whereas methyl groups in the "anti" form will be in a different environment from the other two, and so two doublets will occur ( $\tau = 8.69$  and  $8.87$ ).

The mass spectra of all these compounds follow almost exactly the breakdown scheme recently reported<sup>215</sup> for  $[\text{Fe}(\text{CO})_3\text{SMe}]_2$ ; the six CO groups are lost consecutively to produce the carbonyl-free ion  $[\text{Fe}_2(\text{SR})_2]^+$  which decomposes by stepwise loss of the group R giving  $[\text{Fe}_2\text{S}_2]^+$ . This can then either lose S, giving  $[\text{Fe}_2\text{S}]^+$  which breaks down to  $\text{Fe}^+$  and  $\text{FeS}$ , or it can lose  $\text{FeS}_2$  leaving a bare  $\text{Fe}^+$  ion. The persistence of dimetallic ions throughout the spectrum is now being recognised<sup>241</sup> as a characteristic of dinuclear species (it also occurs

FIG. 3-2

Proton magnetic resonance spectrum of  $[\text{Fe}(\text{CO})_3\text{SPr}^i]_2$



for polynuclear ones), and further examples occur in Chapters 4 and 5.

#### 4. The Reactions of Iron Carbonyl Hydride with Triphenylphosphine and Triphenylarsine

##### a) Reaction with Triphenylphosphine

This reaction, usually conducted in toluene or hexane solution, always led to the formation of either pure  $\text{Fe}(\text{CO})_3(\text{PPh}_3)_2$ , a mixture of mono- and di-substituted iron carbonyls, or pure  $\text{Fe}(\text{CO})_4(\text{PPh}_3)$ , depending solely on the relative quantities of the reactants

##### (i) Preparation of $\text{Fe}(\text{CO})_3(\text{PPh}_3)_2$ :

Approximately 1 ml. of the hydride was condensed onto triphenylphosphine (3.5 g.) and toluene (20 ml.) at  $-196^\circ$ . On allowing the mixture to warm, no reaction was observed until  $0^\circ\text{C}$ , when very slow gas evolution commenced. At room temperature, all the material dissolved and the effervescence was accompanied by the deposition of pale yellow crystals. The reaction ceased after about 45 mins., so the crystals were filtered from the dark coloured solution, washed with pentane and recrystallised from  $\text{CH}_2\text{Cl}_2$ .

The product was characterised by its infrared spectrum (Table 3-3), melting point ( $269^\circ\text{d}$ ; c.f.  $272^\circ$  <sup>242</sup>), and analysis. Obtained C, 69.6; H, 4.54%;  $\text{FeC}_{39}\text{H}_{30}\text{O}_3\text{P}_2$  requires C, 70.5; H, 4.52%.



(ii) Preparation of  $\text{Fe}(\text{CO})_4(\text{PPh}_3)$

$\text{Fe}(\text{CO})_4\text{H}_2$  ( $\sim 1$  ml.) was condensed on to the phosphine (1.0 g.), the reaction occurring in toluene solution under identical conditions to those obtaining in (i). The pure sample of the monosubstituted carbonyl obtained was characterised by its infrared spectrum (Table 3-3), melting point ( $200-204^\circ\text{d}$ ; Lit.  $201-203^\circ$  <sup>242</sup>) and analysis.

Found C, 55.6; H, 3.61%;  $\text{C}_{22}\text{H}_{15}\text{PFeO}_4$  requires C, 55.9; H, 3.49%

Table 3-3

Bands in the Carbonyl Region of the Infrared Spectra of  $\text{Fe}(\text{CO})_4\text{L}$  and  $\text{Fe}(\text{CO})_3\text{L}_2$  (L =  $\text{Ph}_3\text{P}$ ,  $\text{Ph}_3\text{As}$ ), in  $\text{CHCl}_3$  solution

Compound	Symmetry	$\nu(\text{C-O})$ observed	Lit. values <sup>243</sup>
$\text{Fe}(\text{CO})_4\text{PPh}_3$	Axial-Trigonal Bipyramidal ( $\text{C}_{3v}$ )	2053(s), 1977(m), 1942(s)	2055, 1978, 1943
$\text{Fe}(\text{CO})_4\text{AsPh}_3$		2052(s), 1975(m), 1942(s)	2054, 1977, 1945
$\text{Fe}(\text{CO})_3(\text{PPh}_3)_2$	Trans-Trigonal Bipyramidal ( $\text{D}_{3h}$ )	1884(s)	1885
$\text{Fe}(\text{CO})_3(\text{AsPh}_3)_2$		1883(s)	1884

(iii) Separation of Mixtures of  $\text{Fe}(\text{CO})_3(\text{Ph}_3\text{P})_2$  and  $\text{Fe}(\text{CO})_4(\text{Ph}_3\text{P})$

Generally, a mixture of the two substituted carbonyls was obtained. These were readily separated by fractional sublimation, although chromatography on alumina, or fractional crystallisation (from a  $\text{CHCl}_3$ /hexane mixture) were also successful.

The gases evolved in these reactions were usually mixtures of CO and H<sub>2</sub> (by mass spectrometry) although in the one case when only Fe(CO)<sub>4</sub>(Ph<sub>3</sub>P) was obtained, there was very little CO produced.

The dark solutions often obtained from these reactions contained an unstable carbonyl complex, but in only very small quantities. The product was assumed to be a polynuclear hydride species formed by the thermal decomposition of the hydride, but this now appears doubtful when compared with the arsine reaction to be described.

b) Reaction with Triphenylarsine

This reaction was performed several times as follows. The hydride was condensed on to the arsine in a frozen hexane or toluene solution, and the mixture was then warmed to 0°C, where it was maintained for ~48 hrs. In most cases, the major product was a mixture of Fe(CO)<sub>4</sub>(AsPh<sub>3</sub>) and Fe(CO)<sub>3</sub>(AsPh<sub>3</sub>)<sub>2</sub>, although both the substituted carbonyls alone were obtained under appropriate conditions. (These products were purified and characterised by methods similar to those for the phosphine analogues). In addition, a third brown-black product was obtained in small yield, which was soluble in hexane (the arsine substituted carbonyls are almost insoluble in this solvent). This is believed to have the stoichiometry H<sub>2</sub>Fe(CO)<sub>4</sub>AsPh<sub>3</sub> on the basis of the following information.

### Isolation of $\text{Fe}(\text{CO})_4\text{H}_2\text{AsPh}_3$

$\text{Fe}(\text{CO})_4\text{H}_2$  ( $\sim 10$  ml.) was condensed into a reaction flask which contained triphenylarsine (12 g.) and hexane (60 ml.). The black solution produced over 48 hrs. at  $0^\circ\text{C}$  was filtered from the mass of arsine-substituted iron carbonyl and unreacted arsine, and cooled to  $-40^\circ$  overnight. The large, chunky black crystals were redissolved in hexane at  $0^\circ$  and recrystallised. The product was then filtered off, washed with a small quantity of cold hexane and pumped dry. The yield by this procedure varied between nil and 0.5 g.

### Properties

The black crystals are highly air sensitive, some samples being pyrophoric, glowing brightly and giving off grey-white fumes, possibly of subliming  $\text{Ph}_3\text{As}$ .  $\text{Fe}_3(\text{CO})_{12}$  could be extracted in cyclohexane from the residue of such a decomposition, suggesting the presence of an  $\text{Fe}(\text{CO})_4$  moiety in the compound. It decomposes slowly at room temperature as a solid, even in a  $\text{N}_2$  atmosphere and more rapidly ( $\sim 72$  hrs.) in solution. Both  $\text{Fe}_3(\text{CO})_{12}$  and  $\text{Fe}(\text{CO})_4\text{AsPh}_3$  could be isolated from such solutions after decomposition.

### Analyses

Because of the pyrophoric nature of this compound, analysis for C and H content by combustion was only attempted twice. On one occasion, the following results were obtained - Found C, 56.0; H, 3.37%;  $\text{FeAsC}_{22}\text{H}_{17}\text{O}_4$  requires C, 55.5; H, 3.57% - but on attempting to repeat

such an analysis, the sample exploded in the oxygen stream.

A determination of the CO:H<sub>2</sub> ratio was not attempted because the compound decomposes at room temperature, but when a sample was warmed gently on the vacuum line, it melted to a brown-yellow liquid which gave off a grey-white sublimate. The gases evolved were shown to be a mixture of CO and H<sub>2</sub> by mass spectrometry.

#### Proton Magnetic Resonance Spectrum

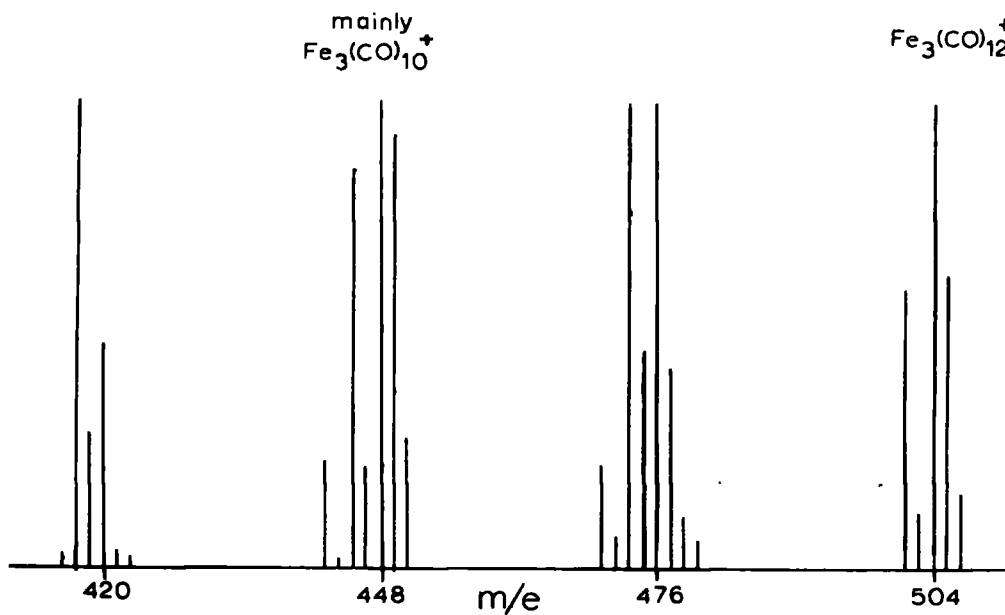
An attempt was made to record the p.m.r. spectrum of this material, but the sample decomposed rapidly at the temperature of the instrument ( 35°) giving a green solution (Fe<sub>3</sub>(CO)<sub>12</sub>), but the multiplets at 2.5-2.7  $\tau$  arising from the phenyl groups were observed (in hexane, C<sub>6</sub>D<sub>6</sub> and CHCl<sub>3</sub> solutions). With the recent acquisition of a low temperature probe, p.m.r. measurements at 0° may be more successful.

#### Mass Spectroscopic Data

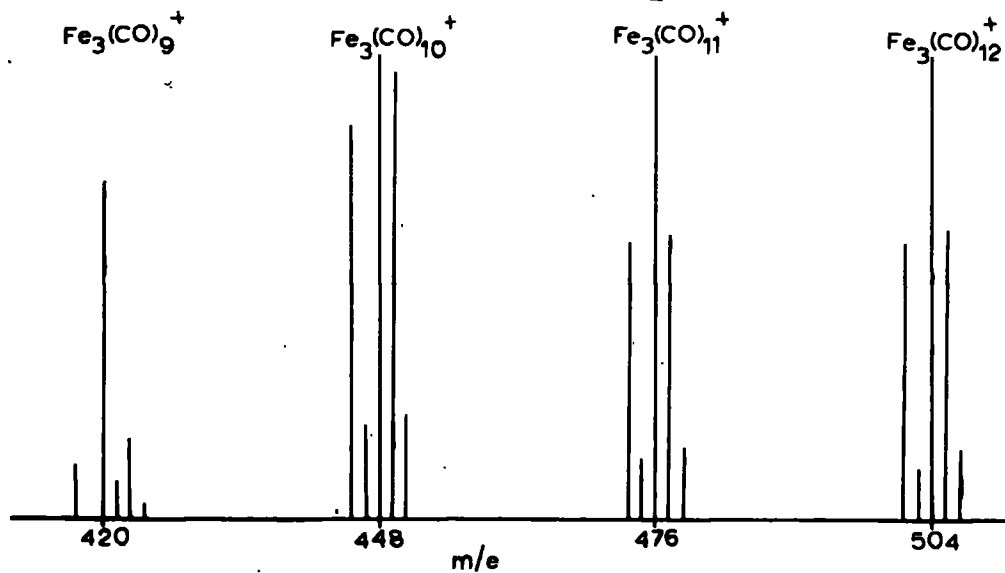
A low-resolution mass spectrum of a freshly prepared sample was recorded, the sample being introduced on the direct insertion probe. The spectrum obtained showed the parent ion and breakdown pattern associated with Fe<sub>3</sub>(CO)<sub>12</sub>, together with a superimposed, much more intense spectrum of Ph<sub>3</sub>As. However, the isotope patterns of the ions corresponding to [Fe<sub>3</sub>(CO)<sub>11</sub>]<sup>+</sup>, [Fe<sub>3</sub>(CO)<sub>10</sub>]<sup>+</sup> and [Fe<sub>3</sub>(CO)<sub>9</sub>]<sup>+</sup> were different from the patterns observed in the spectrum of a pure sample of Fe<sub>3</sub>(CO)<sub>12</sub>. The patterns corresponding to these ions are

FIG. 3-3.

Part of Mass Spectrum Produced by  $\text{Fe}(\text{CO})_4\text{H}_2\text{As}(\text{Ph})_3$ .  
(Expanded)



Part of spectrum of  $\text{Fe}_3(\text{CO})_{12}$  (Expanded).



reproduced in Fig.3-3. High resolution mass measurements at the nominal masses corresponding to these ions were therefore carried out using perfluorotri-n-butylamine as internal standard; the mass ratios being relative to the fragment of exact mass 463.97431. The results, together with the assignments based on the known accurate masses for the elements involved, are presented in Table 3-4.

Table 3-4

Nominal Mass	Mass † Observed	Assignment	Mass Calculated	ΔM * (p.p.m.)
476	475.9705	$^{56}\text{Fe}(\text{CO})_4\text{As}(\text{C}_6\text{H}_5)_3\text{H}_2$	475.9692	3
	475.7500	$(^{56}\text{Fe})_3(\text{CO})_{11}$	475.7489	2
474	473.7526	$(^{56}\text{Fe})_2(^{54}\text{Fe})(\text{CO})_{11}$	473.7535	2
448	447.7518	$(^{56}\text{Fe})_3(\text{CO})_{10}$	447.7540	5
420	419.7586	$(^{56}\text{Fe})_3(\text{CO})_9$	419.7590	1
	419.9782	$^{56}\text{Fe}(\text{CO})_2\text{As}(\text{C}_6\text{H}_5)_3\text{H}_2$	419.9794	3

† Temperature Corrected

$$*\Delta M = [M_{\text{obs}} - M_{\text{calc}}]$$

A freshly introduced sample was used for each mass measurement. The accuracy of the M.S.9 was considered to be better than 10 p.p.m. under the conditions used, and inspection of the results shows that the instrumental accuracy was ~5 p.p.m.

The peak at 475.9705 was the only peak observed at this nominal mass, apart from the  $[\text{Fe}_3(\text{CO})_{11}]^+$  ion. Of the many possible ions giving rise to such a peak, as a result of combinations of  $^{13}\text{C}$ ,  $^{54}\text{Fe}$ ,  $^{56}\text{Fe}$  and  $^{57}\text{Fe}$ , the most likely combinations are listed in Table 3-5 below.

Table 3-5

Possible Ion	$M_{\text{calc}}$	$\Delta M$ (p.p.m.)
$^{57}\text{Fe}(\text{CO})_4\text{As}(\text{C}_6\text{H}_5)_3\text{H}$	475.9616	15
$^{56}\text{Fe}^{13}\text{CC}_{21}\text{H}_{16}\text{As}$	475.9647	10
$^{56}\text{Fe}^{13}\text{C}_2\text{C}_{20}\text{H}_{15}\text{As}$	475.9606	19

All the individual parts of the isotope combination pattern of the  $[\text{Fe}_3(\text{CO})_{11}]^+$  ion are approximately 400 p.p.m. distant from the observed peak. An unsuccessful search was made for the ions listed in Table 3-5. All of these would be much less intense than the peaks corresponding to a combination of the most abundant isotopes of the elements involved, and since the mass-discrepancy  $\Delta M$  for each is outside the limits of the accuracy of the measurements, it was concluded that the peak observed cannot be assigned to these ions, and that the peak at mass 475.9705 is best assigned to the ion  $[\text{H}_2\text{Fe}(\text{CO})_4\text{AsPh}_3]^+$ .

A high accuracy search was made for ions arising in the breakdown pattern of this parent ion, assuming that the most likely losses would be of CO, as was suggested by the low resolution spectrum, or of H or H<sub>2</sub>. The peaks found in the search, together with assignments are shown in Table 3-4. Ions corresponding to [HFe(CO)<sub>4</sub>AsPh<sub>3</sub>]<sup>+</sup> (i.e. (P-H)<sup>+</sup>), (Fe(CO)<sub>4</sub>AsPh<sub>3</sub>]<sup>+</sup> (i.e. (P-H<sub>2</sub>)<sup>+</sup>) and [H<sub>2</sub>Fe(CO)<sub>3</sub>AsPh<sub>3</sub>]<sup>+</sup> (i.e. (P-CO)<sup>+</sup>) were not found, suggesting that they were either not present, or too weak in intensity. As with P<sup>+</sup> itself, no isotopic combination corresponds as well as (P-2CO)<sup>+</sup> to the peak observed at mass 419.9782. The presence of this ion in the mass spectrum confirms that the primary breakdown of the molecular ion is by loss of CO, rather than by loss of hydrogen, although the latter possibility cannot be discounted on this evidence as an alternative breakdown could lead to ions of low intensity.

#### Infrared Spectrum

In hexane solution C-O stretching bands were observed at 2052(w), 2027(s), 2007(s) and 1953(m). This spectrum did not change when the hexane solution was stirred for several hours with D<sub>2</sub>O, even when this contained a little acid, indicating that these bands are C-O stretching modes rather than Fe-H stretching modes. Further, if the hydrogens are present terminally bound, ν(Fe-H) would be expected below 1900 cm<sup>-1</sup>, by comparison with Fe(CO)<sub>4</sub>H<sub>2</sub> itself (see Part II) and other carbonyl hydride systems.<sup>244</sup> The spectrum of a Nujol mull



of this compound shows only bands attributable to carbonyl groups and  $\text{Ph}_3\text{As}$ .

### Mossbauer Spectrum

A sample made up in silicone grease in the standard way (see Part II) gave the following Mossbauer parameters. Only two peaks were observed; the isomer shift,  $\delta$ , was  $0.37 \text{ mm. sec}^{-1}$  and the quadrupole splitting,  $\Delta$ , was  $0.42 \text{ mm. sec}^{-1}$ . The significance of these values will be discussed later.

### c) Discussion

#### (i) Formation of $\text{Fe}(\text{CO})_4\text{L}$ and $\text{Fe}(\text{CO})_3\text{L}_2$

The direct reactions of the iron carbonyls in general with ligands containing phosphorus, arsenic or antimony as the donor atom have to be initiated thermally, or by use of ultraviolet radiation,<sup>13</sup> and produce mixtures of  $\text{Fe}(\text{CO})_4\text{L}$  and  $\text{Fe}(\text{CO})_3\text{L}_2$ . The monosubstituted derivatives often predominate when milder conditions are used, and the latter under more drastic conditions. Even  $\text{Fe}_3(\text{CO})_{12}$  reacts with these ligands only in refluxing THF or dioxan.<sup>243</sup> The formation of these complexes from  $\text{Fe}(\text{CO})_4\text{H}_2$  is similar in that mixtures are again formed, but the reaction is easily constrained to yield only one product.

As in the reaction with thiols, the very high reactivity of the hydride is responsible for the rapid formation of the products under mild conditions, and in both cases it seems that the most important

feature of the chemistry of  $\text{Fe}(\text{CO})_4\text{H}_2$  is the ease with which it loses both hydrogen atoms, rather than one CO group. This was exemplified at the beginning of this chapter, and has been further illustrated by these reactions.

This is in direct contrast to the carbonyl monohydrides, which form ligand substituted hydrides readily (Table 3-1), and is also, surprisingly, quite different from the behaviour of  $\text{H}_2\text{Os}(\text{CO})_4$ . Both  $\text{Fe}(\text{CO})_4\text{H}_2$  and  $\text{Os}(\text{CO})_4\text{H}_2$  have the same cis-octahedral structure (see Part II), but appear to be quite different chemically. Thus,  $\text{H}_2\text{Os}(\text{CO})_4$  is air stable, and gives the substitution product  $\text{H}_2\text{Os}(\text{CO})_3\text{PPh}_3$  readily,<sup>223</sup> although hydrogen substitution does occur in halogenated solvents to give  $\text{Os}(\text{CO})_4\text{X}_2$ . This great difference in the reactivity and thermal stability of hydrido-complexes of iron and their analogues of the heavier metals in the group is a characteristic of transition metal hydrides in general,<sup>244</sup> and the increased strength of the M-H bond is paralleled, for example, by an increase in  $\nu(\text{M-H})$  when going down a periodic group. However, the reason for the unique behaviour of  $\text{Fe}(\text{CO})_4\text{H}_2$  in ligand substitution reactions is not clear, particularly since the phosphine and arsine complexes  $\text{H}_2\text{Fe}(\text{L}_2)_2$  (L = diphos or diars) and their Ru and Os analogues undergo similar reactions - the iron compounds usually more easily.<sup>244</sup>

(ii) The Compound  $H_2Fe(CO)_4AsPh_3$

This compound is very unusual, and does not appear to have an analogue in any other section of carbonyl hydride chemistry. It appears to be an intermediate species in the formation of  $Fe(CO)_4AsPh_3$  from the hydride, since it decomposes in solution to this compound, but  $Fe_3(CO)_{12}$  was also produced with great regularity in all of the studies of it, and appears to be the major decomposition product, as shown particularly in the mass spectrum. All the chemical and physical properties of this compound are incompatible with an ionic formulation (e.g. it is soluble in hexane and gives a parent ion in the mass spectrometer) and its properties are quite unlike those displayed by the salts of the iron carbonyl hydrides prepared and studied in Part II of this thesis. The remaining obvious possibilities are

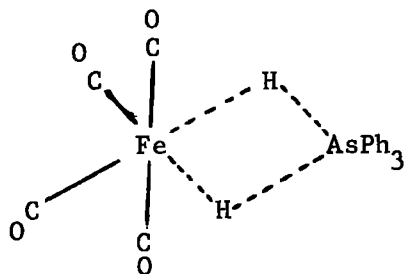
- (a) That the arsine ligand is directly bound to iron by a covalent bond,  
or (b) that it is some kind of "adduct" or charge-transfer complex.

A covalent complex with an Fe-As bond (a) would be based on an iron atom with twenty outer electrons and which would therefore be very unusual in having more than 18 outer electrons. The exceptions to the inert gas rule almost always have less electrons than required. It would also be unusual because the iron atom would be seven-co-ordinate, assuming the hydrogens take up a full co-ordination

position and are bound normally to the metal; or six-co-ordinate, when the two hydrogens would, between them occupy a single co-ordination position. In both of these, since the arsine ligand is directly bound to the iron atom, the decomposition should be mainly by loss of  $H_2$  to yield  $Fe(CO)_4AsPh_3$ . In particular, in the mass spectrum, one would expect to see evidence for the production of the simple substituted carbonyl. In practice, none of this is detected -  $AsPh_3$  is lost readily instead. Thermal decomposition of the complex in the source produces  $Fe_3(CO)_{12}$  which is invariably present in the mass spectrum. Further, the Mossbauer spectrum is probably inconsistent with this type of structure because (a) the quadrupole splitting,  $0.42 \text{ mm. sec}^{-1}$ , is very small, suggestive of a six-co-ordinate structure, and (b) the isomer shift value is much larger than the  $\delta$ -values obtained for all the species  $[Fe(CO)_4H_{2-n}]^{n-}$  ( $n = 0-2$ ) which fall within the range  $0.08-0.095$  (see Part II), whereas  $\sigma$ -donation by a neutral ligand generally outweighs any deshielding of the nucleus produced by  $(d\pi-d\pi)$  interaction and therefore produces a smaller  $\delta$ -value. Thus, for a variety of reasons, a 20-electron complex can probably be discounted.

Probably the most likely geometrical arrangement if this complex is of type (b) is one in which the hydrogen atoms are localised between the iron and arsenic atoms and thus hold the  $Fe(CO)_4$  and  $Ph_3As$  fragments together, as in I, by formation of hydrogen bridges.

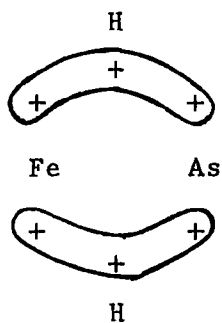
Such a structure, of



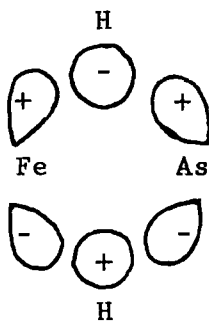
I

$C_{2v}$  symmetry is compatible with the infrared spectrum which shows three strong bands and a weak one to high frequency, and with the low  $\Delta$ -value observed in the Mossbauer spectrum. Structure I would also explain the tendency of the  $Ph_3As$  group to be lost easily under a variety of conditions.

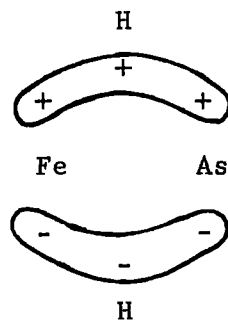
In the  $FeH_2As$  system there are six electrons available for bond formation (two from iron, two from the hydrogen atoms and two from arsenic) which can occupy molecular orbitals constructed from the following six idealised atomic orbitals:  $2 \times Fe(sp^3d^2 \text{ hybrid}) + 2 \times H(1s) + 2 \times As(sp^3d \text{ hybrid})$ . These molecular orbitals, derived from simple symmetry considerations are shown in Fig.3-3, in which the + and - signs refer to the phases of the atomic orbitals considered. Since the bonding orbitals (mainly (i) and (iii)) are delocalised over iron, hydrogen and arsenic, there will be a reduced electron-density on the iron atom compared with the parent hydride, and an increased Mossbauer isomer shift would be expected for the arsine complex, as is



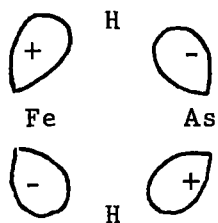
(i) bonding



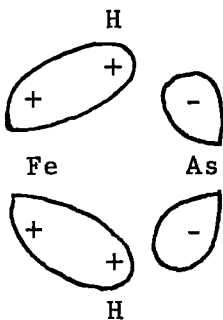
(ii) antibonding



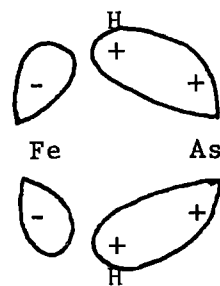
(iii) bonding



(iv) antibonding



(v) Fe-H bonding  
As-H antibonding



(vi) Fe-H antibonding  
As-H bonding

non-bonding

Fig.3-3

observed experimentally. In addition, the intense colour, which is another unusual feature of this complex, can be explained as charge transfer, possibly from (i), (iii) or (v) to (vi) or the antibonding

orbitals, the former possibly being more localised on iron because the atomic orbitals of iron involved in the molecular orbitals are lower in energy than the corresponding arsenic orbitals. Thus, the transitions would involve transfer of electron-density from iron to arsenic.

Obviously these suggestions are tentative, and further work on this complex and related systems will be necessary to understand more completely the processes involved. There is no reason to suppose that the formation of this postulated hydrogen-bridge should be limited to iron carbonyl hydride and triphenylarsine, particularly in view of the apparent ease with which single hydrogen atoms act as bridges between similar transition metals. Thus, if this system is present in this complex, similar, probably more stable complexes may be formed from other cis-dihydrides, such as  $(\pi\text{-C}_5\text{H}_5)_2\text{MH}_2$  (M = Mo, W) or even  $\text{R}_2\text{SnH}_2$  etc.

CHAPTER FOUR

Azomethine Derivatives of Metal Carbonyls - Preliminary Investigations



## 1. Introduction

This chapter will describe preliminary studies of metal carbonyl- and cyclopentadienyl metal carbonyl complexes containing N-bonded azomethine groups (  $C=N^-$  ). It is concerned with reactions of iron, manganese and molybdenum systems; further work on cyclopentadienyl molybdenum tricarbonyl species will be described in Chapter 5.

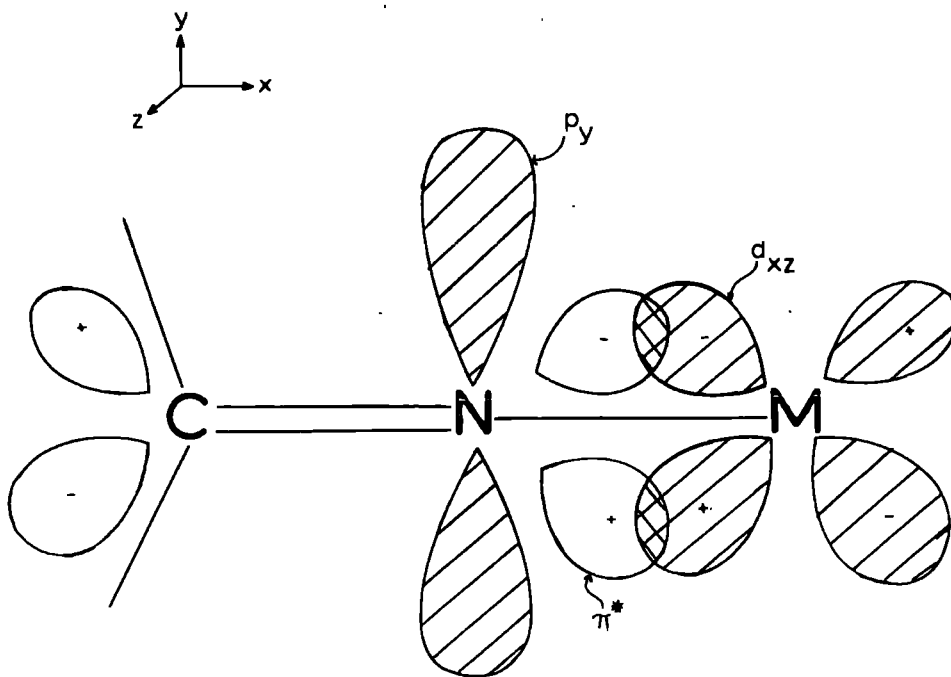
At the outset of this work, few metal carbonyl complexes containing N-bonded anionic ligands were known, although their transient existence was postulated in the metal carbonyl catalyzed cyclization and other reactions of compounds containing  $C=N$ ,  $C\equiv N$ ,  $N=N$ ,  $C=N-N=C$  and similar groups.<sup>245</sup> This study of imino-complexes was initiated in an attempt to isolate complexes of this type, and to investigate the bonding characteristics of the  $C=N^-$  groups as manifested in the changes in carbonyl C-O and azomethine C=N stretching frequencies.

Neutral N-bases, such as amines are strong Lewis bases, but their tendency to form substitution complexes with the metal carbonyls is limited by their inability to take part in  $\pi$ -bonding, as described in Chapter 1, whereas unsaturated ligands, such as pyridine, can accept  $\pi$ -electrons from the metal and imino-ligands were chosen for this investigation for this latter reason.

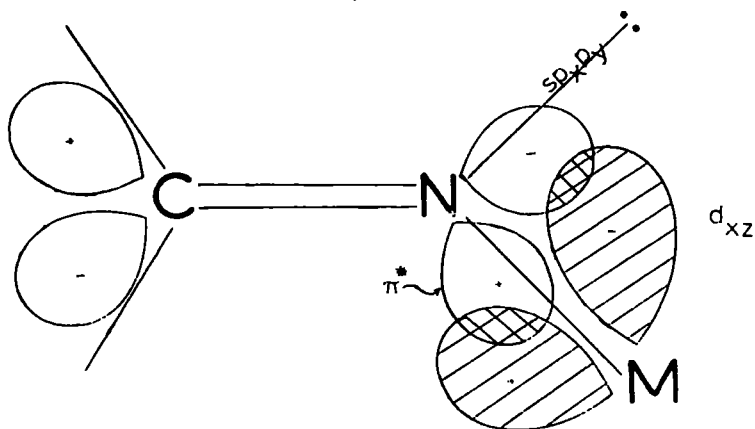
The two most likely geometrical arrangements of the relevant atoms is shown in Fig.4-1. A linear M-N-C skeleton (a) would require the

**FIG.4-1**

The  $\sigma$ -bond skeleton and  $\pi$ -orbitals involved in metal-imine bonding.



a). Overlap of  $Md_{xz}$  with  $\pi^*(C-N)$  for linear M-N-C unit.



b). Overlap of  $Md_{xz}$  with  $\pi^*(C-N)$  for trigonal nitrogen

the nitrogen lone-pair to occupy a pure p-orbital ( $p_y$  in the Fig.) but would allow coplanarity, and therefore maximum overlap of the metal d and ligand  $\pi$  orbitals as shown. In addition, if the  $p_y$  lone pair is able to overlap with a suitable metal d-orbital in the xy plane, the system will be a three electron donor analogous to the nitrosyl group.

In the other extreme (b), based on trigonal nitrogen, the lone-pair is in an  $sp^2$  hybrid orbital (written  $sp_x p_y$  in the Fig. to indicate the orientation of the system with respect to the axes drawn), but there will be reduced  $d \rightarrow \pi^*$  back-donation. In this context, the contribution of such a lone pair to  $L \rightarrow M$  bonding by  $(p \rightarrow d)\pi$ -bond formation could be significant, particularly for the earlier transition elements which have partially unfilled d-orbitals. Indeed, Ebsworth<sup>246</sup> has calculated overlap integrals, and on the basis of his results has argued that substantial  $(p \rightarrow d)\pi$ -bonding from a nitrogen lone pair to empty silicon d orbitals is possible in a non-linear system. However, this does not seem to apply in the iminosilanes ( $R_2C=N-SiMe_3$ ), whose u.v. spectra<sup>247</sup> have been interpreted to show that (a) the C-N-Si skeleton is bent, and (b) that there is very little multiple-bond character in the Si-N link. If these results can be applied to the transition metals, where the d-orbitals are at least partly filled, they would imply an angular arrangement based on  $sp^{1-2}$  hybridisation at the nitrogen atom, and that the lone-pair is therefore

available for donation to a second metal atom.

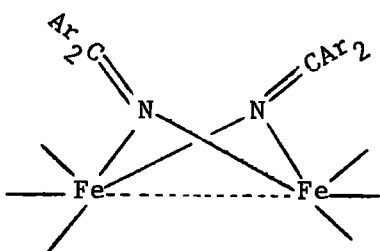
In a ligand-bridged dinuclear complex, overlap of d-orbitals on both metal atoms with the  $(C-N)\pi^*$  orbital can occur: the C-N bond would then be weakened and its vibrational frequency would probably be lower than in the case where the ligand does not bridge, and lower than in the free ketimine or ketimino-derivatives of the main group elements. In other words the bridging  $C=N^{\ominus}$  unit is isoelectronic with the bridging carbonyl group, so trends in  $\nu(C-N)$  might be expected to parallel those for  $\nu(C-O)$  in comparable systems.

This type of bonding scheme should be contrasted with that used to describe the bonding in the P-, As- or S-bridged complexes, where  $d\pi \rightarrow d\pi$  interaction is much stronger than the  $\pi$ -interaction in say pyridine complexes.<sup>248</sup>

While this work was in progress, several complexes containing anionic ligands bound to metal carbonyl fragments via a nitrogen atom have been reported. Four of these are shown in Fig.4-2. The most significant of these, from the point of view of this thesis, is the compound I prepared from iron pentacarbonyl and  $Ar_2C=N-N=CAr_2$ .<sup>249</sup> The structure is entirely consistent with  $sp^2$  hybridised nitrogen, and the Fe-N distance is shorter than in any other reported iron carbonyl-nitrogen complex, compatible with substantial Fe-N double-bonding, as implied in the above description. Unfortunately, the C-N stretching frequency was not given, so a further discussion of the

Fig.4-2

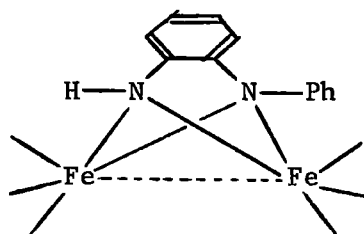
Structures of some Iron Carbonyl Complexes containing N-bonded Ligands



I

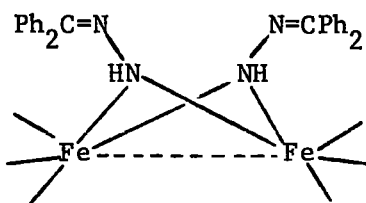
(Ar = CH<sub>3</sub>·C<sub>6</sub>H<sub>4</sub>·)

(Fe-N)<sub>av.</sub> = 1.94 Å



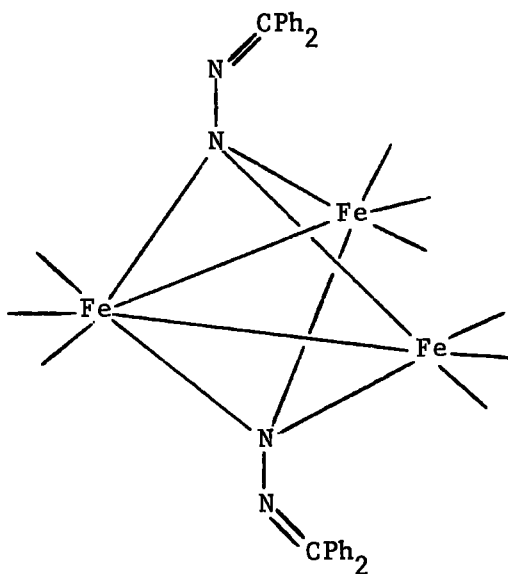
II

(Fe-N)<sub>av.</sub> = 2.01 Å



III

(Fe-N)<sub>av.</sub> = 2.00 Å



IV

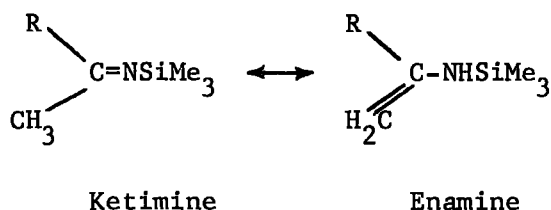
bonding in this compound from this point of view is not possible. However, the existence and structure of this complex confirms some of the ideas presented above.

The average Fe-N distances in complexes II<sup>250</sup> and III<sup>251</sup> are the same, and longer than that of the ketimino complex I. They are, in fact, indicative of essentially single Fe-N bonds<sup>251</sup> as would be expected when no multiple bonding is possible. (The N atom is sp<sup>3</sup> hybridised). Finally, compound IV,<sup>252</sup> prepared from iron carbonyl and diaryldiazomethane,<sup>251</sup> contains a triply-bridging nitrogen atom, and shows (together with the other examples) that nitrogen is capable of co-ordination to polynuclear metal systems in ways at least as varied as carbon.

## 2. Possible Synthetic Routes to Ketimino-Metal Carbonyl Complexes

The general principles considered when choosing possible routes to a complex containing an anionic ligand have been outlined in Chapter 1. One reason for choosing diphenylketimine and its derivatives as starting materials for this study, apart from the different possible modes of bonding than can be envisaged, was the ready availability of these compounds, largely as a result of the work by Dr. K. Wade of this department and his co-workers into azomethine derivatives of main-group organometallic compounds, and I am very grateful to him for making many of his results available prior to publication.

The synthesis of dialkyl ketimines has been reported by the addition of Grignards<sup>253</sup> or alkylaluminium<sup>254</sup> compounds to the corresponding nitrile and subsequent hydrolysis of the product. These preparations could not be repeated in these laboratories,<sup>255</sup> however, probably because the hydrogen in the  $\alpha$ -position in ketimines enters into enamine tautomerism<sup>256</sup> as has been observed for iminosilanes;<sup>247</sup> i.e.

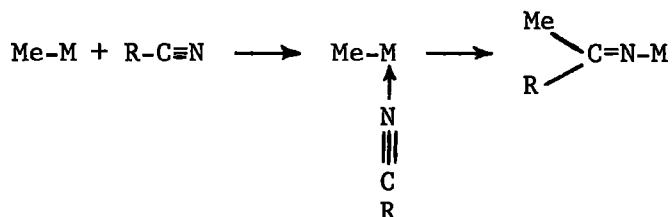


The labile hydrogen atom is acidic and liberation of alkane from Grignards or alkylaluminium compounds has been observed<sup>257</sup> and this factor is probably responsible for the difficulty in preparing alkyl-ketimines. This work was therefore limited to aryl-ketimines.

The reactions that have been tried in the course of this work are as follows:

- (i)  $\text{Na}[\text{M}(\text{CO})_n] + \text{Ph}_2\text{C}=\text{NBr}$
- (ii)  $\text{M}(\text{CO})_n\text{Cl} + \text{Ph}_2\text{C}=\text{NM}' \quad (\text{M}' = \text{Na}, \text{Li}, \text{MgBr}, \text{SiMe}_3)$
- (iii)  $\text{M}(\text{CO})_n\text{Cl} + \text{Ph}_2\text{C}=\text{NH} \xrightarrow{\text{base}}$
- (iv)  $[\text{CpMo}(\text{CO})_3]_2 + \text{Ph}_2\text{C}=\text{N}-\text{N}=\text{CPh}_2 \xrightarrow{\text{u.v.}}$
- (v) Addition of  $\text{Me-Mn}(\text{CO})_5$  to  $\text{R}-\text{C}\equiv\text{N}$

The principles involved in most of these reactions have already been discussed. Method (V), however, requires a little explanation at this point. It is an extension of the insertion reaction, typical of many organometallic compounds<sup>258-9</sup> shown in the scheme below.



When methyl manganese carbonyl is involved, however, the alternative insertio of CO into the Mn-CH<sub>3</sub> bond giving an acylmanganese carbonyl complex has to be considered. A variety of Lewis bases<sup>260</sup> which are strong donors are known to promote this carbonylation process, although significantly, unsaturated ligands do not. Thus, phenyl isocyanide, which is a weak donor, replaces the methyl groups<sup>261</sup> while CF<sub>2</sub>=CF<sub>2</sub>, which has no donor properties still reacts to give only CH<sub>3</sub>CF<sub>2</sub>CF<sub>2</sub>Mn(CO)<sub>5</sub>.<sup>262</sup> Diphenylketimine probably falls halfway between these apparent limits.

### 3. Diphenylketimine as a Neutral Base

As a preliminary to the study of the reactions of diphenylketimino compounds with metal carbonyl derivatives, some of the reactions of the parent imine itself were investigated in order to assess its base strength and bonding characteristics. The reactions



with manganese carbonyl halides were chosen because their substitution reactions have been studied with many neutral ligands, and the factors influencing the formation and stability of the products are well understood.<sup>263</sup>

a) Reaction with Manganese Pentacarbonyl Bromide

The carbonyl (0.84 g. 3 mmole) in chloroform solution (30 ml.) was stirred at room temperature with  $\text{Ph}_2\text{C}=\text{NH}$  (1.5 ml. 9 mmole) overnight. CO was evolved very slowly. The solution was then reduced to about 5 ml. and the product precipitated by the addition of hexane (20 ml.) and filtered. (The solution contains some  $\text{Mn}_2(\text{CO})_{10}$  which is formed in the reaction. The yellow  $\text{Mn}(\text{CO})_3(\text{Ph}_2\text{C}=\text{NH})_2\text{Br}$  was recrystallised from a  $\text{CHCl}_3$ /hexane mixture, washed with hexane, and pumped dry. Yield 1.22 g. (58%).

Obtained C, 60.4; H, 4.0; Br, 13.8%.  $\text{MnC}_{29}\text{H}_{22}\text{N}_2\text{O}_3\text{Br}$  requires C, 59.9; H, 3.8; 13.6%.

This complex was shown to be a non-electrolyte in nitrobenzene solution.

b) Reaction with Manganese Pentacarbonyl Chloride

An entirely analogous reaction occurred between  $\text{Mn}(\text{CO})_5\text{Cl}$  and  $\text{Ph}_2\text{C}=\text{NH}$  to give  $\text{Mn}(\text{CO})_3(\text{Ph}_2\text{C}=\text{NH})_2\text{Cl}$  as pale yellow crystals from a mixture of chloroform and hexane.

Obtained C, 64.3; H, 4.21; Cl, 6.4%.  $\text{MnC}_{29}\text{H}_{22}\text{N}_2\text{O}_3\text{Cl}$  requires C, 64.8; H, 4.01; Cl, 6.7%.

Both these compounds decomposed in refluxing benzene and in a sublimation apparatus ( $\sim 120^\circ$ ,  $10^{-3}$  mm), the brown oil collected on the cold finger being a solution of  $\text{Mn}_2(\text{CO})_{10}$  in free diphenylketimine, according to its infrared spectrum. The complexes do not react with triphenylphosphine in refluxing chloroform, and an attempt to prepare the nitrite by stirring the complex with  $\text{NaNO}_2$  in acetone was unsuccessful.

c) Reaction of  $\text{Mn}(\text{CO})_3(\text{Ph}_2\text{C}=\text{NH})_2\text{Br}$  with 2,2'-Bipyridyl

The carbonyl (0.505 g., 0.87 mmoles) and bipyridyl (0.146 g., 1.1 mmoles) were refluxed in chloroform under  $\text{N}_2$ . The solution slowly went orange and some decomposition to a white solid occurred. After 24 hrs. the solution was cooled, filtered and the yellow product precipitated by the addition of hexane. Recrystallisation (3 times) from a  $\text{CHCl}_3$ /hexane mixture gave  $\text{Mn}(\text{CO})_3\text{bipyBr}$  as yellow crystals. Obtained C, 37.41; H, 2.10; Br, 22.0; N, 8.11%.  $\text{MnC}_{11}\text{H}_6\text{N}_2\text{O}_3\text{Br}$  requires C, 37.83, H, 1.72; Br, 22.93; N, 8.02%.

d) Discussion

These reactions verify that diphenylketimine acts as a normal N-base, giving  $\text{Mn}(\text{CO})_3\text{L}_2\text{X}$ ,<sup>13</sup> and that the chelating ligand 2,2'-bipyridyl will displace the two monodentate ligands, although triphenylphosphine has no effect. The C-O stretching frequencies (Table 4-1) of all these complexes are similar, indicating that the bonding characteristics of this neutral ligand are as expected for a

nitrogen atom which is part of a  $\pi$ -bonded system. The three strong bands are consistent with the three carbonyl groups being in mutually

Table 4-1

The Infrared Spectra of  $\text{Mn}(\text{CO})_3\text{L}_2\text{X}$  compounds

Complex	$\nu(\text{C-O})$	$\nu(\text{N-H})$	$\nu(\text{C=N})$
$\text{Mn}(\text{CO})_3(\text{Ph}_2\text{C=NH})_2\text{Br}$	2030(s), 1950(s), 1925(s)	3215	1616(m), 1597(m)
$\text{Mn}(\text{CO})_3(\text{Ph}_2\text{C=NH})_2\text{Cl}$	2034(s), 1951(s), 1927(s)	3215	1618(m), 1597(m)
$\text{Mn}(\text{CO})_3\text{bipyBr}$	2034(s), 1947(s), 1932(s)	-	-

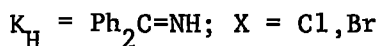
cis-positions. The complex would then be of  $C_s$  symmetry for which three strong bands,  $2A' + A''$ , are predicted.<sup>264</sup>

The N-H stretching frequencies are some  $50\text{ cm}^{-1}$  lower than in the free ligand ( $3260\text{ cm}^{-1}$ ), which would be consistent with electron-withdrawal from nitrogen via the  $\sigma$ -bond upon co-ordination - similar shifts of between  $50$  and  $100\text{ cm}^{-1}$  have been observed in morpholine and other complexes<sup>265</sup> - but there is no distinct trend in the behaviour of  $\nu(\text{N-H})$  in complexes of diphenylketimine, as shown in Table 4-2.

Two bands are observed in the C=N stretching region of the spectrum, but their frequencies ( $1616$  and  $1597\text{ cm}^{-1}$ ) span that of the free imine ( $1603\text{ cm}^{-1}$ ) showing that this parameter is affected very little upon co-ordination of the ligand, as has been observed also for complexes with main group metals.<sup>268</sup>

Table 4-2Positions of  $\nu(\text{N-H})$  in Some Complexes of Diphenylketimine

Complex	$\nu(\text{N-H})$	Ref.
$\text{K}_\text{H}$	3260	This work
$\text{Mn}(\text{CO})_3\text{K}_\text{H}\text{X}$	3215	This work
$\text{Co}(\text{K}_\text{H})_2\text{Cl}_2$	3279	266
$\text{Co}(\text{K}_\text{H})\text{PPh}_3\text{Cl}_2$	3279	266
$\text{CuCl}\cdot\text{K}_\text{H}$	3200	267
$\text{CuCl}_2\cdot 2\text{K}_\text{H}$	3281	267



#### 4. Attempts to prepare Diphenylketiminomanganese Carbonyl Complexes

##### a) Reaction between $\text{Ph}_2\text{C}=\text{NH}$ and $\text{Mn}(\text{CO})_5\text{Cl}$ in the presence of $\text{MgCO}_3$

The reaction between  $\text{Mn}(\text{CO})_5\text{Cl}$  (1.4 g.) and  $\text{Ph}_2\text{C}=\text{NH}$  in 1:1 molar proportions in both chloroform and ether solution in the presence of excess  $\text{MgCO}_3$ , to induce elimination of  $\text{HCl}$ , was attempted. Slow  $\text{CO}$  evolution occurred at room temperature and the only isolable carbonyl complex, apart from starting material, was  $\text{Mn}(\text{CO})_3(\text{Ph}_2\text{C}=\text{NH})_2\text{Cl}$ , as characterised by its infrared spectrum and analysis (for C and H). It was therefore concluded that either the hydrogen atom in the free imine is not sufficiently acidic to take part in the attempted type

of reaction, even when weakened (as shown by  $\nu(\text{N-H})$ ) by co-ordination, or that since the stability of octahedral Mn(I) carbonyl complexes reaches a maximum at  $\text{Mn}(\text{CO})_3\text{L}_2\text{X}$ , the elimination of HCl is energetically unfavourable compared with formation of the observed product.

b) Reaction between  $\text{Mn}(\text{CO})_5\text{Cl}$  and  $\text{Ph}_2\text{C}=\text{NMgBr}$

A solution containing 3.6 mmoles of PhMgBr in ether was treated dropwise with an excess of phenyl cyanide (0.5 ml., 4.8 mmoles) in a double Schlenk tube. A white precipitate of  $\text{Ph}_2\text{C}=\text{NMgBr}$ <sup>253</sup> immediately formed, but the mixture was stirred for a further hour to ensure complete reaction. The solvent ether was then removed under vacuum and the excess cyanide removed from the white, powdery precipitate by washing with dry hexane (2 x 20 ml.).  $\text{Mn}(\text{CO})_5\text{Cl}$  (3.6 mmoles) in chloroform (30 ml.) was then added but since no reaction occurred at room temperature overnight, the mixture was refluxed. After 3 hrs. the deep red solution which had formed was filtered and evaporated, and the residue extracted from unreacted  $\text{Mn}(\text{CO})_5\text{Cl}$  into toluene. On removal of the solvent, a deep red oil was obtained, whose infrared spectrum showed the presence of more than one compound. Attempts to separate the mixture by fractional crystallisation and chromatography (on alumina and silica) were unsuccessful. The positions of the C-O stretching bands are consistent with this product being a mixture of compounds I and II to be described in Section 4c.

When the reaction was performed in toluene at 55-60° a similar mixture resulted, but no reaction occurred in refluxing ether, probably because the temperature was too low.

c) Reaction between Mn(CO)<sub>5</sub>Cl and Ph<sub>2</sub>C=NLi

A solution containing Ph<sub>2</sub>C=NLi (3.6 mmoles) was prepared as follows.<sup>269</sup> A solution of Ph<sub>2</sub>C=NH in ether (20 ml.) was frozen to -196° in one limb of a double Schlenk tube and an equimolar quantity of n-butyl lithium in hexane added by syringe (Methyl lithium in ether can be used equally successfully<sup>269</sup>). The mixture was then allowed to warm to room temperature and stirred for two hours to allow complete reaction. To the resulting deep red/orange solution was added Mn(CO)<sub>5</sub>Cl (1 g. 3.6 mmoles), also in ether. When no reaction occurred at room temperature (18 hrs.), the solvent was changed to THF and the mixture refluxed for 2 hrs., when a deep red colour was produced. The THF was then removed in vacuo and Mn<sub>2</sub>(CO)<sub>10</sub>, present in 20% according to the infrared spectrum, was washed out into hexane. The carbonyl products were then extracted using toluene (2 x 20 ml.) which was then removed to yield a deep-red, thick oil.

As before, this was a mixture which could not be separated by chromatography, but one fraction (yellow) was apparently slightly less soluble in most solvents tried than the red one, and separation by fractional crystallisation was finally successful. After about ten crystallisations from a 1:1 mixture of chloroform and hexane, a

yellow powder (I) which could not be obtained as crystals, and glistening red needles (II) were obtained.

I was very soluble in chloroform and dichloromethane, but was unstable in solution, decomposing to a brown-yellow non-carbonyl residue. However, this complex is believed to be  $\text{Mn}(\text{CO})_n\text{N:CPh}_2$  ( $n = 4$  or  $5$ ) on the basis of the following evidence. Inconsistent analytical data were obtained for different recrystallised samples; the range of the results being C, 55.2-58.9%; H, 2.42-3.43% ( $\text{Mn}(\text{CO})_5\text{N:CPh}_2$  requires C, 57.6; H, 2.67% and  $\text{Mn}(\text{CO})_4\text{N:CPh}_2$  requires C, 58.8; H, 2.88%). No halogen was detected in the product. The important features of the infrared spectrum are shown in Table 4-3, together with assignments. Numerous other bands typical of phenyl groups were also observed between 1500 and 600  $\text{cm}^{-1}$ . There is no N-H stretching band in the spectrum.

Table 4-3

$\nu(\text{C-O}) (\text{cm}^{-1})$	2058(w), 2042(s, sharp), 1912(s, broad)
$\nu(\text{C=N}) (\text{cm}^{-1})$	1613(m)

Both  $\text{Mn}(\text{CO})_5\text{N:CPh}_2$  ( $\text{C}_{4v}$ ) and  $\text{Mn}(\text{CO})_4\text{N:CPh}_2$  (assuming  $\text{C}_{3v}$  symmetry) would give rise to this type of spectrum, three C-O stretching modes ( $2A_1 + E$ ) being predicted for each, assuming that the ketimino ligand does

not affect the symmetry too much. The tetracarbonyl complex would be analogous to  $\text{Mn}(\text{CO})_4\text{NO}$ ,<sup>270</sup> assuming the Mn-N-C skeleton to be linear and would thus be of pure  $\text{C}_{3v}$  symmetry. On the other hand, a bent M-N-C skeleton would be expected for  $\text{Mn}(\text{CO})_5\text{NPh}_2$ , which would reduce the symmetry, at least sufficiently, probably to split the low frequency E mode. In the solid state (Nujol mull) the broad band is asymmetric, but only slightly, an effect that may be the result of crystal symmetry, particularly since this asymmetry is not observed in solution. Further, the separation between the strong bands is greater than in  $\text{Mn}(\text{CO})_5\text{X}$  (X = halogen) for example. This evidence is suggestive, therefore that the complex is  $\text{Mn}(\text{CO})_4\text{N:CPh}_2$ , which by analogy with  $\text{Mn}(\text{CO})_4\text{NO}$  itself might be expected to be rather unstable, but this can only be a tentative suggestion. The complex decomposed in the mass spectrometer, thus precluding its identification by this means, although the  $\text{Ph}_2\text{C=N}$  fragment was observed.

The red complex (II), although much more stable in all respects than I, was obtained in insufficient quantity (25 mg.) to allow characterisation. Further attempts to isolate it were unsuccessful - only red oils were produced. In Nujol, five sharp C-O stretching bands are observed (at 2028(m), 1998(s), 1942(s), 1916(s) and 1838(s), but in solution the spectrum changes ( $\nu(\text{C-O})$  at 2110(w), 2032(s), 2008(s), 1942(s), 1923(s)). However, in the absence of definitive information no explanation of this behaviour is offered. All the



bands typical of phenyl groups are present, but there is no band in the C=N stretching region. The analytical data (C,64.9; 65.01; H, 4.28,4.26; N,4.61,5.05%) were not consistent with any obvious formulation, and the compound decomposed in the mass spectrometer, only peaks characteristic of  $\text{Ph}_2\text{C}=\text{N}$  groups being observed.

d) Reaction between  $\text{MeMn}(\text{CO})_5$  and Acetonitrile

$\text{MeMn}(\text{CO})_5$  (0.17 g., 0.8 mmole) and excess acetonitrile (0.1 g.) were stirred overnight at room temperature in hexane, but no observable reaction occurred. No reaction took place when the solution was refluxed for 24 hrs., and irradiation with ultraviolet light for two hours caused only some decomposition to a non-carbonyl residue.

e) Reaction between  $\text{Mn}(\text{CO})_5\text{Br}$  and  $\text{Ph}_2\text{C}=\text{NSiMe}_3$

$\text{Mn}(\text{CO})_5\text{Br}$  (0.7 g. 2.5 mmoles) and 0.8 ml. (2.6 mmoles) imino-silane were stirred at  $60^\circ$  in monoglyme. Slow evolution of gas occurred. The infrared spectrum of a sample of the product showed that some  $\text{Mn}(\text{CO})_5\text{Br}$  remained after 14 hrs. A further 0.9 ml. imino-silane were therefore added, and after two hours the solution was reduced in bulk to  $\sim 4$  mls., and hexane (20 ml.) added to precipitate a yellow solid. This was recrystallised from  $\text{CHCl}_3/\text{hexane}$  and shown to be  $\text{Mn}(\text{CO})_3(\text{Ph}_2\text{C}=\text{NH})_2\text{Br}$ . ~~C = 59.9, H = 3.8.~~ Obtained C,60.4; H,4.1%; Required C,59.9; H,3.8%;  $\nu(\text{C}-\text{O})$  at 2030, 1951 and  $1924 \text{ cm}^{-1}$ ). The source of the hydrogen introduced into the ligand in this reaction is assumed to be the solvent.

f) Conclusions

The reactions between  $\text{Ph}_2\text{C=NLi}$  or  $\text{Ph}_2\text{C=NMgBr}$  and  $\text{Mn(CO)}_5\text{X}$  (X = Br or Cl) both gave mixtures of products which only be separated by a long and difficult fractional crystallisation procedure. One of these products gave the expected infrared spectrum for  $\text{Mn(CO)}_5(\text{N=CPh}_2)$  or  $\text{Mn(CO)}_4(\text{N=CPh}_2)$  but the compound could not be satisfactorily characterised because of its tendency to decompose in solution. No evidence that this decomposition proceeded via a dimeric tetracarbonyl complex was obtained.

5. Attempts to prepare Cyclopentadienyliron carbonyl - imino complexes

a) Reaction between  $\text{CpFe(CO)}_2\text{Br}$  and  $\text{Ph}_2\text{C=NMgBr}$

$\text{Ph}_2\text{C=NMgBr}$  (4.5 mmoles) was prepared as described earlier.  $\text{CpFe(CO)}_2\text{Br}$  (1.25 g., 5.0 mmoles) was added and the mixture stirred in benzene (50 ml.) overnight, but no reaction occurred. The mixture was therefore refluxed for  $\sim 3\frac{1}{2}$  hrs., when some changes were noted in the C-O region of the infrared spectrum. The solution was pumped dry and an ether extract chromatographed on alumina (neutral). Elution with a petroleum ether/ether mixture (4:1) gave only  $\text{CpFe(CO)}_2\text{Br}$  and a little  $[\text{CpFe(CO)}_2]_2$  (both recognised by their infrared spectra).

In ether solution, the same reactants gave a complex mixture of products, and although partial separation was affected by chromatography on alumina, the quantities of each product were so small that they could not be characterised.

b) Reaction between  $\text{CpFe}(\text{CO})_2\text{Cl}$  and  $\text{Ph}_2\text{C}=\text{NLi}$  or  $\text{Ph}_2\text{C}=\text{NNa}$

Both these reactions gave similar results and were performed under identical conditions. The only difference being in the method of preparation of the ketimine salt.

A solution of  $\text{Ph}_2\text{C}=\text{NLi}$  in ether was prepared as described earlier. The ether was pumped off and to the yellow residue was added an equimolar quantity of the carbonyl in THF solution.

The sodium salt was prepared by syringing a slight excess of  $\text{Ph}_2\text{C}=\text{NH}$  in THF (10 ml.) on to sodium hydride which had previously been analysed for hydride content by measurement of the  $\text{H}_2$  evolved on hydrolysis. The mixture was stirred until evolution of  $\text{H}_2$  ceased, the THF was removed in vacuo and the excess imine washed out using hexane. The carbonyl was then added to the resulting solid in THF solution.

No detectable reaction occurred over several hours at room temperature, so the mixture was maintained at  $50^\circ\text{C}$  for 24 hrs. The THF was then removed and the black residue extracted with chloroform (8 ml.). Starting material (recovered in 60% yield) was separated from the other component in this deep red-brown extract by chromatography by virtue of its greater retention on a 40 x 2 cm alumina (Grade III acid) column using a 2:1 hexane/ $\text{CHCl}_3$  mixture as elutant. The product was further separated from minor products of the reaction by chromatography on a 60 x 5 cm column (Grade I alumina),

using 4:1 hexane/ $\text{CHCl}_3$  as elutant. Evaporation of the solvent then gave a yellow-orange crystalline solid which was recrystallised from hexane. Mpt.  $163-4^\circ\text{C}$ . Obtained C, 65.9; H, 5.27%. The infrared spectrum showed two C-O stretching frequencies at 2048(s) and 1980(s) and strong peaks typical of  $\pi\text{-C}_5\text{H}_5$  at 1110, 1006 and  $816\text{ cm}^{-1}$ . There are therefore no  $\text{Ph}_2\text{C}=\text{N}$  groups present, and the identity of this compound remains unknown. In the mass spectrometer, only peaks arising from ferrocene were observed, showing that the compound had decomposed in the instrument.

When the reaction between  $\text{Ph}_2\text{C}=\text{NLi}$  and  $\text{CpFe}(\text{CO})_2\text{Cl}$  in 2:1 molar ratio quantites,  $\text{CpFe}(\text{CO})_2\text{Cl}$  ( $\sim 25\%$ ),  $[\text{CpFe}(\text{CO})_2]_2$  ( $\sim 5\%$ ) and an unstable monocarbonyl species were separated by chromatography, but the last of these could not be characterised.

#### 6. Sealed-tube reactions between $[\text{CpMo}(\text{CO})_3]_2$ and Azines

There was no indication that any new carbonyl complexes were formed when  $[\text{CpMo}(\text{CO})_3]_2$  and an azine were heated together in sealed tubes. Further, the CO evolved in the process of decomposition, measured in a gas-burette, and the weight of starting material recovered, were equivalent to more than 96% of the carbonyl used. The azines, solvents and temperatures used are shown in Table 4-4.

Table 4-4

Azine Used	Reactant Quantities		Solvent	Temp.	Time (hrs)	% Decomposition
	Azine	Carbonyl				
$(\text{PhC(H)=N})_2$	2.1 mmole	2.04 mmole	None	110	24	-
"	"	"	"	150	"	11.5
"	1.95	1.94	Toluene	80	"	-
"	"	"	"	150	16	11.2
$(\text{Me}_2\text{C=N})_2$	2.1	2.04	"	200	"	-
"	"	"	None	"	"	-

#### 7. Photochemical synthesis of $\text{CpMo(CO)}_3\text{Hal}$ and $\text{CpFe(CO)}_2\text{Hal}$

This new, and very convenient synthetic route to these halides (Hal = Cl, Br, I) was discovered accidentally while trying to prepare imino-molybdenum complexes by irradiation of  $[\text{CpMo(CO)}_3]_2$  in the presence of azines. This possible method of synthesis was attempted using both benzaldehyde azine and acetazine in toluene and cyclohexane solution for times varying between 30 mins. and the time resulting in total decomposition of the carbonyl. Silica flasks were used each time. In no case was there any indication of the formation of a new compound.

When the same reaction was attempted in chloroform solution (using benzaldehyde azine), the infrared spectra of samples withdrawn

at intervals from the reaction showed the appearance and growth of new bands, and the disappearance of the bands arising from  $[\text{CpMo}(\text{CO})_3]_2$ . When the spectrum showed the reaction to be complete, the product was crystallised by removal of most of the solvent and adding hexane. The orange crystalline solid was shown to be  $\text{CpMo}(\text{CO})_3\text{Cl}$  by analysis and infrared spectroscopy.

Similar reactions occurred using  $\text{CCl}_4$ ,  $\text{CHBr}_3$ ,  $\text{CHI}_3$  (in toluene or cyclohexane solution), and irradiation of  $[\text{CpFe}(\text{CO})_2]_2$  gave  $\text{CpFe}(\text{CO})_2\text{Hal}$  with each of these. In all cases, the reactions were essentially quantitative. The following procedure was found to give a quantitative yield of  $\text{CpMo}(\text{CO})_3\text{Cl}$  and can readily be adapted to give the other halides.

#### Preparation of $\text{CpMo}(\text{CO})_3\text{Cl}$

The carbonyl was dissolved in ten times its weight of  $\text{CHCl}_3$ , in a silica flask to which was attached a reflux condenser. The flask was then evacuated and filled with nitrogen. The apparatus was placed at least 60 cm from a 1 Kilowatt ultraviolet lamp in a well ventilated cupboard (to keep the temperature as low as possible) and the solution stirred vigorously while irradiation took place. When the reaction was complete (a 5 gm. quantity of  $[\text{CpMo}(\text{CO})_3]_2$  requires  $1\frac{1}{2}$  -  $1\frac{3}{4}$  hrs.) and the apparatus had cooled to room temperature, the volume of solution was doubled by the addition of hexane or petroleum ether and

filtered. The bulk of the solution was then reduced to about 20 ml. on a rotary evaporator, and the solution set in a refrigerator to crystallise.

Providing the temperature does not rise above about 35<sup>o</sup>, and that the lamp is switched off as soon as the reaction is complete, the reaction is quantitative. If some decomposition occurs, the decomposition products precipitate out on the addition of hexane, so the product isolated from the filtered solution is usually still pure enough for preparative purposes. In the preparation of CpFe(CO)<sub>2</sub>Hal, it is essential, in view of the light sensitivity of cyclopentadienyl iron carbonyl compounds, that the irradiation is stopped as soon as the reaction is complete. The infrared spectrum of the reaction solution in the carbonyl stretching region is an easy and rapid source of this information. Up to 10 g. of the carbonyl can be used without a noticeable reduction in the yield, but the longer irradiation period necessary for greater quantities results in some photochemical decomposition.

Since these halides were used extensively in this work, this preparative procedure proved to be far more convenient than the methods available in the literature. Thus, although the iodides are readily obtained from the parent dimers by reaction with I<sub>2</sub>, the yields are generally less than quantitative, CpMo(CO)<sub>3</sub>Cl and the bromide are only available, in very low yield in Mo, via the

hydride,<sup>271</sup> and the corresponding iron compounds are prepared by reaction of  $[\text{CpFe}(\text{CO})_2]_2$  with halogens<sup>272-3</sup> - a procedure usually accompanied by some oxidation to a non-carbonyl.



CHAPTER FIVE

$\pi$ -Cyclopentadienylmolybdenum Carbonyl Complexes Containing  
Organo-nitrogen Ligands

In this chapter, further attempts to synthesise cyclopentadienyl-molybdenum carbonyl complexes containing the  $\text{Ph}_2\text{C}=\text{N}^-$  ligand by the synthetic routes described in Chapter 4 are described.

1. Reaction between Cyclopentadienylmolybdenum tricarbonyl halides and Diphenylketiminolithium

Using either the carbonyl chloride or iodide under identical conditions, this reaction gave the same products, and in each case the reaction did not go to completion until a second molar quantity of  $\text{Ph}_2\text{C}=\text{NLi}$  had been added. Infrared spectra of samples of the reaction solution withdrawn at intervals showed that reaction between equimolar quantities of the reactants occurred over about two hours, but that half the  $\text{CpMo}(\text{CO})_3\text{X}$  remained and did not react further, even after 24 hrs. However, when a second molar quantity of  $\text{Ph}_2\text{C}=\text{NLi}$  was added, the carbonyl halide was totally consumed after a further two hours. The following is typical of the procedure used for this reaction.

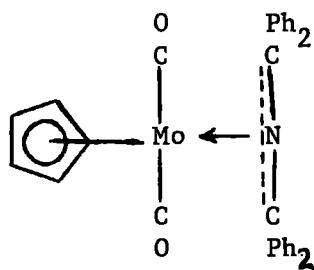
a) Reaction between  $\text{CpMo}(\text{CO})_3\text{Cl}$  and  $\text{Ph}_2\text{C}=\text{NLi}$

A solution of  $\text{Ph}_2\text{C}=\text{NLi}$  in ether was prepared by addition of an ethereal solution of methyl lithium (7.3 mmoles) to diphenylketimine (7.3 mmoles) in ether (40 ml.). This solution was added by syringe against a counter-stream of nitrogen to a frozen ( $-196^\circ$ ) solution of  $\text{CpMo}(\text{CO})_3\text{Cl}$  (1.022 g., 3.65 mmoles) in ether (20 ml.). The mixture was then allowed to warm to room temperature and was stirred for two

hours, when precipitation of a white powder was accompanied by slow evolution of carbon monoxide, and the red-orange solution became deep-purple. When the reaction was complete, as indicated by infrared spectroscopy, the ether was removed under vacuum and the residue extracted with chloroform (100 ml.).

The purple solution was filtered from a grey-white solid (which contained some LiCl), and the product crystallised by the addition of hexane (30 ml.) and cooling the solution to  $-20^{\circ}$  overnight. The waxy, golden-brown crystals obtained were filtered, washed with petroleum ether and recrystallised from a hexane/chloroform mixture. Yield 1.5 g. M.Pt., 203-205d.

This complex is believed, on the basis of the following evidence, to be a nitrogen containing analogue of  $CpMo(CO)_2(\pi\text{-allyl})$  with structure I



I

Properties: Even after several recrystallisations, the compound had a waxy appearance and could be compressed into a dense mass, although

when originally filtered, it appeared crystalline. It is stable for long periods in air, but does lose CO over several months to leave a brown residue. It is unaffected by concentrated boiling alkalis, but dissolves in conc.  $H_2SO_4$  to give an orange solution which soon starts to evolve CO. It is almost insoluble in hexane, benzene and toluene, but is soluble in  $CHCl_3$  and ethers, although not to a large extent. Its solutions are intensely purple, even when dilute, although the solid never appears this colour. Strangely, on passing down an alumina column (in  $CHCl_3$ ), the originally purple band sometimes turned yellow, but the yellow eluate quickly reverted to its original colour. The visible spectrum of the golden-brown solid (by reflectance) and purple solution ( $CHCl_3$ ) were the same ( $\lambda_{max}$  at 430, 536  $m\mu$ ); the instability of the yellow solutions meant that their spectra could not be recorded, so no explanation is offered for this behaviour.

Analyses: This compound was prepared several times, and although satisfactory values were obtained for H, N and CO, the carbon figure was always about 5% lower than required, even after several recrystallisations and/or chromatography. These results are shown in Table 5-1.



Table 5-1

	%C	%H	%N	%CO
$C_{33}H_{25}MoNO_2$ requires	70.1	4.46	2.48	9.9
Average Value Obtained	65.1	4.34	2.65	9.5
Spread of Results	64.1-65.6	3.87-4.71	2.45-2.86	-
Number of Results	7	6	4	1

No explanation of this behaviour is offered, and no satisfactory formulation fits these values. The above formulation and structure is therefore based on the following evidence.

Molecular Weight (Determines osmometrically in  $CHCl_3$ ). The low solubility of this compound meant that the maximum useable concentration was only about 1% by weight, and so the osmometer was not being used under ideal conditions. The following are results obtained on two separately prepared samples

Sample	% by weight	$M_{calc.}$	Average
I	{ 0.98	541	565
	{ 0.91	544	
II	{ 0.98	579	
	{ 0.38	595	

For the above formulation the required molecular weight is 563.

Infrared Spectrum: Two sharp C-O stretching frequencies (1938(s) and 1835(s)  $\text{cm}^{-1}$ ) and numerous other bands typical of either  $\pi\text{-C}_5\text{H}_5$  or phenyl groups were observed. There were no bands assignable to  $\nu(\text{C}=\text{N})$  or  $\nu(\text{N}-\text{H})$ .

P.M.R. Spectrum: The spectrum consists of a sharp singlet (5.24 $\tau$ ) due to the protons in the  $\pi\text{-C}_5\text{H}_5$  ring,<sup>274</sup> and a multiplet (2.7 $\tau$ ), typical of phenyl groups, in an intensity ratio of 4:1, showing the presence of four equivalent phenyl groups per cyclopentadienyl group.

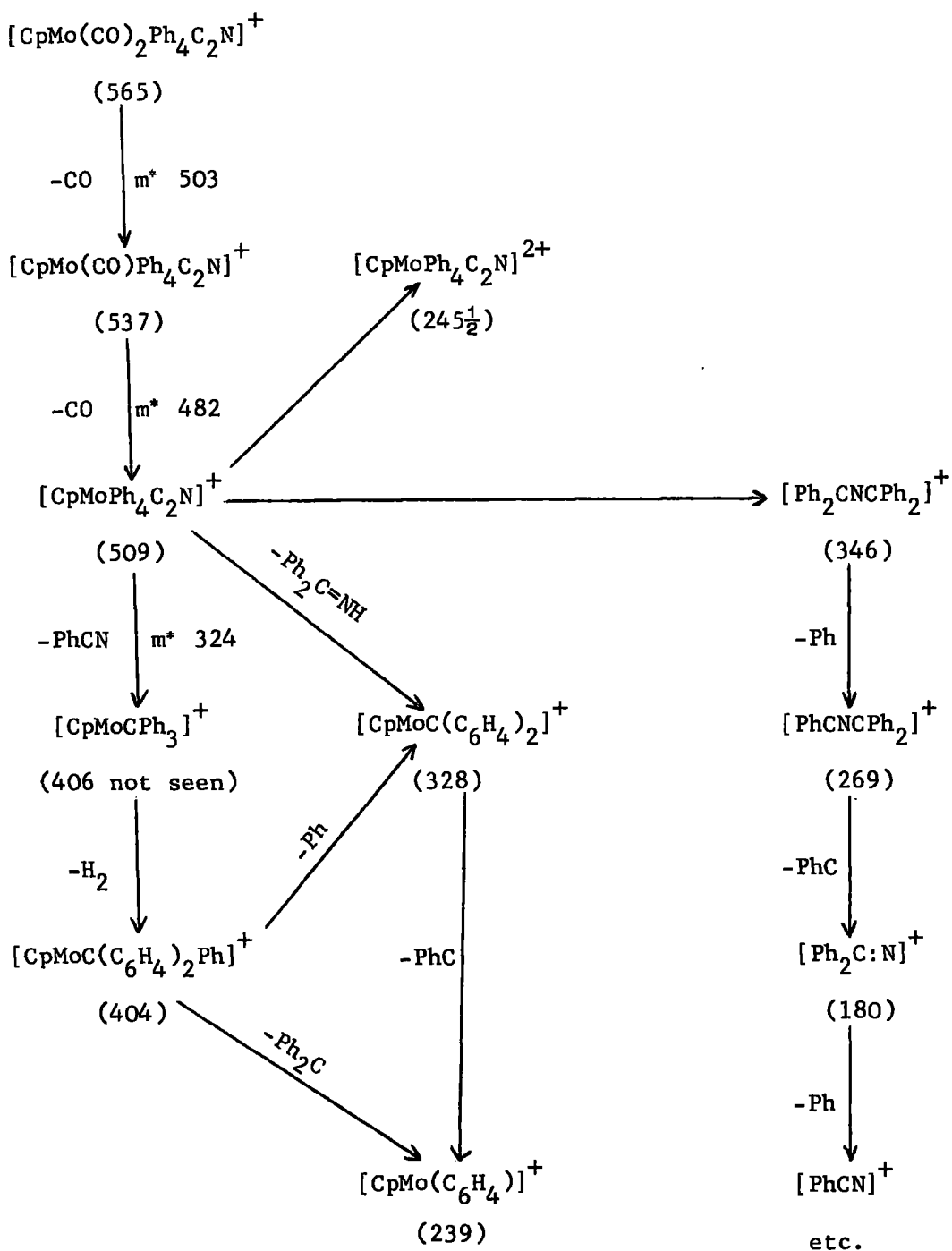
Conductivity: The complex is a non-electrolyte in nitrobenzene solution.

Mass Spectrum: (Direct Insertion Probe). This is the most confirmatory evidence for the proposed formulation. The proposed breakdown scheme is shown in Fig.5-1. All masses are quoted for <sup>98</sup>Mo, the most abundant naturally occurring isotope of molybdenum. The parent ion, corresponding to  $[\pi\text{-C}_5\text{H}_5\text{Mo}(\text{CO})_2(\text{Ph}_2\text{CNCPh}_2)]^+$ , initially loses two CO groups, and the isotope patterns of the three ions  $\text{P}^+$ ,  $(\text{P}-\text{CO})^+$  and  $(\text{P}-2\text{CO})^+$  correspond well with the pattern calculated for a mononuclear Mo species corrected for 32 carbon atoms (See App.4). The presence of the parent organic fragment at 346 units was particularly helpful in the interpretation of the spectrum, and indeed its breakdown pattern is consistent with the formulation  $[\text{Ph}_2\text{C}-\overset{+}{\text{N}}-\text{CPh}_2]$ .

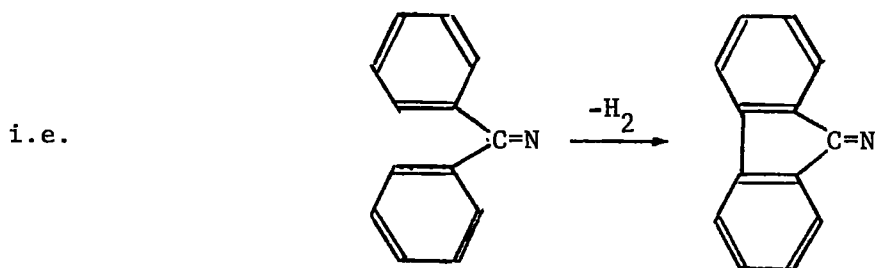
The patterns of the Mo-containing ions below 509 units are much more complex than is necessary for a single Mo atom, but do not

Fig. 5-1

Proposed Fragmentation Scheme for  $\pi\text{-C}_5\text{H}_5\text{Mo(CO)}_2\text{Ph}_2\text{CNCPh}_2$



correspond to a  $\text{Mo}_2$  species. They are best interpreted as being the result of overlap of patterns arising from two ions which differ by 2 mass units; i.e. the ion formed in a particular fragmentation process loses  $\text{H}_2$ , as well as following the primary breakdown route. This is to be expected when organic groups, particularly phenyl groups,<sup>214</sup> are present, and loss of  $\text{H}_2$  has also been detected for the  $\pi$ -allyl complex  $\pi\text{-C}_3\text{H}_5\text{Mo}(\text{CO})_2\text{Cp}$ .<sup>214</sup> For the complex under discussion, where adjacent phenyl groups are present, the facile loss of  $\text{H}_2$  may be explained by ortho-coupling<sup>293</sup>



Of particular interest in this context is the loss of  $\text{PhCN}$  from  $(\text{P-2CO})^+$ . Although this fragmentation is proved by the observed metastable at 324 ( $M_{\text{calc}}^* = (406)^2/509 = 324$ ), there is no ion at 406 units. Instead, two overlapping patterns corresponding to the ions derived from 406 by loss of  $\text{H}_2$  and  $2\text{H}_2$  are observed at 404 and 402.

Finally, the doubly charged ion at  $245\frac{1}{2}$  units is typical of the behaviour of heavier elements in a mass spectrometer. King<sup>214</sup> has



observed doubly charged Mo species regularly in  $\pi$ -cyclopentadienyl derivatives, and similar results will be described later. In fact, the presence of doubly charged ions corresponding to the most stable ions in the spectrum seems to be a characteristic feature of the mass spectra of organo-molybdenum complexes.

#### Reaction with $\text{Ph}_3\text{P}$

No reaction between this product and  $\text{Ph}_3\text{P}$  was observed in either refluxing  $\text{CHCl}_3$  or toluene.

#### b) Discussion

All the evidence available on this complex, except for the low analysis figures for carbon, are consistent with the formulation  $\pi\text{-C}_5\text{H}_5\text{Mo}(\text{CO})_2(\text{Ph}_2\text{CNCPh}_2)$ , and the presence of four phenyl groups per  $\pi\text{-C}_5\text{H}_5$  group shown by the p.m.r. spectrum explains the experimentally observed fact that the formation of this complex is only complete after the addition of 2 moles of  $\text{Ph}_2\text{C=NLi}$  to 1 mole of  $\text{CpMo}(\text{CO})_3\text{Cl}$ . The mass spectrum shows that the group  $\text{Ph}_2\text{CNCPh}_2$  is a single ligand, which, in a dicarbonyl complex, will be a three-electron donor. The proposed structure, I, is analogous to the well known  $\pi\text{-C}_5\text{H}_5\text{Mo}(\text{CO})_2(\pi\text{-allyl})$ .<sup>275</sup> However, the effect of the nitrogen lone-pair (replacing the C-H bond in a  $\pi$ -allyl group) on the bonding characteristics of the ligand needs to be considered.

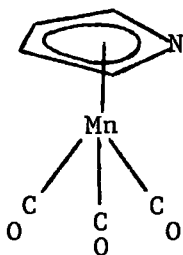
Complexes of several different  $\pi$ -bonded ligands which contain a nitrogen atom are available for comparison. In general,  $\pi$ -bonded

heterocyclic ligands are somewhat less strongly bound to the metal atoms than their carbocyclic analogues, and their complexes, which are therefore less stable, are much more difficult to prepare. This is probably because the  $\pi$ -system of the ring is less available for symmetrical bonding to the metal because it will be distorted by the presence of the electronegative nitrogen atom. Thus, while the physical properties of both  $\pi$ -pyrrolyl manganese tricarbonyl<sup>276</sup> (Fig.5-2, I) and azaferrocene<sup>277-8</sup> (Fig.5-2,II) closely parallel those of the parent cyclopentadienyl complexes, the nitrogen atom in the  $C_4H_4N$  ring is only weakly basic in both cases, suggesting that the nitrogen lone-pair is involved in M-L bonding, but contributing insufficiently to overcome the weakening of the M-L bond that results from the presence of a nitrogen atom. Note that the lone-pair is coplanar with the ring, and therefore directed away from the metal; this will also be the case for  $\pi$ -pyridine chromium tricarbonyl<sup>279-280</sup> (Fig.5-2,III).

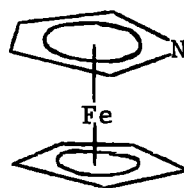
Donors containing the  $-RC=NR$  system appear able to complex to metals either by formation of N-M  $\sigma$ -bonds (Fig.5-2,IV<sup>281</sup>) or by use of the  $\pi$ -bond (Fig.5-2,V<sup>282</sup>), while dialkyl cyanamides give dimeric nickel complexes (Fig.5-2,VI) in which the ligand is believed<sup>283-4</sup> to donate three electrons in a similar way to a  $\pi$ -allyl group. Thus, donation is possible via the (C-N) $\pi$ -system and/or the lone-pair. These two possibilities have to be considered for this particular

Fig.5-2

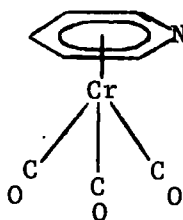
Some Metal Complexes of  $\pi$ -bonded, Nitrogen-containing Ligands



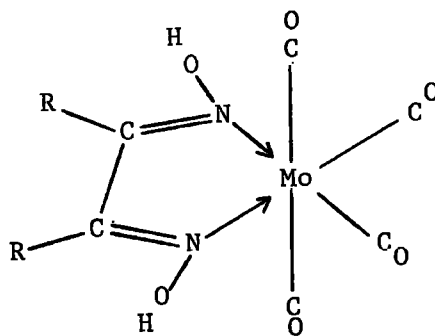
I



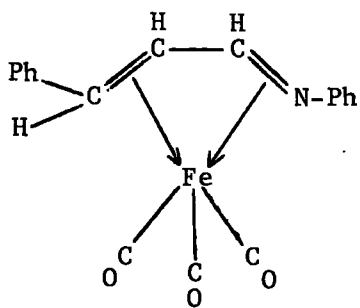
II



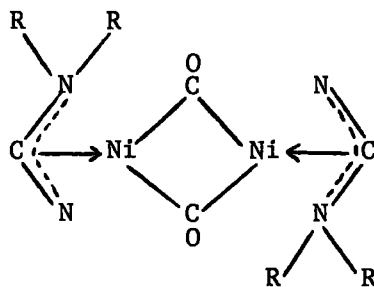
III



IV



V



VI

2-aza-allyl ligand. In the following discussion, the ligand is considered, purely for ease of explanation, to be negatively charged, and therefore donating four electrons to the positive metal. Thus, the (C-N-C) $\pi$ -system contains four electrons, and the nitrogen has a lone-pair of electrons. The two extreme situations are shown in Fig.5-3. Structure (a) is directly analogous to the bonding of the

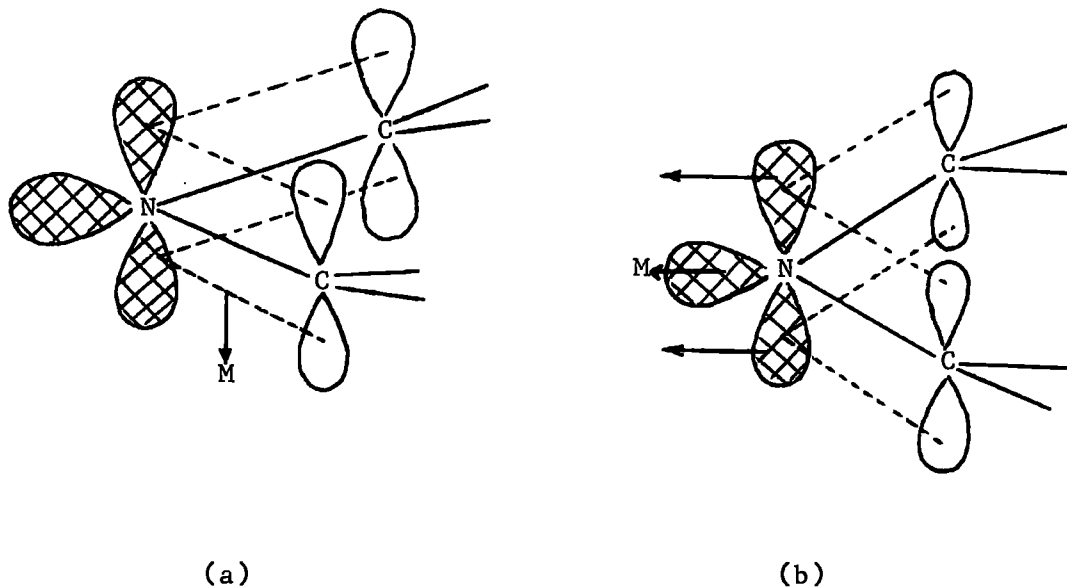


Fig.5-3 Ligand orbitals possibly involved in M-L bonding.

isoelectronic  $\pi$ -allyl group. In both cases the empty metal  $\sigma$ - and  $\pi$ -orbitals have the correct symmetry for overlap. In one extreme (a) the metal orbitals of both  $\sigma$ - and  $\pi$ -symmetry accept electrons to give a bonding situation which is directly comparable to that postulated<sup>299</sup> in  $\pi$ -allyl complexes. In case (b) the nitrogen lone-pair

$\sigma$ -bonds to the metal allowing the metal  $t_{2g}$  orbitals to overlap with the  $\pi$ -orbitals of the ligand. Since there is an extra charge, mainly localised on the nitrogen atom in this pseudo-allyl ligand, forward co-ordination of ligand  $\pi$ -electrons may be more favourable than in the corresponding  $\sigma$ -pyridine complexes, and allow the ligand to act as a four-electron donor.

Thus, either of the extreme situations shown in (a) and (b) seem to be possible. However, some intermediate situation is possibly more likely, in which the nitrogen atom is nearer to the metal than the carbon atoms because of involvement of the nitrogen lone-pair.<sup>246</sup>

c) Reaction between  $\text{Ph}_2\text{C}=\text{N}-\text{C}(\text{Cl})\text{Ph}_2$  and  $\text{Na}[\text{CpMo}(\text{CO})_3]$

In order to confirm the presence of the pseudo-allyl group in the molybdenum complex, the chloroderivative of the ligand was synthesised from diphenylketiminolithium and dichlorodiphenylmethane.<sup>285</sup> Attempts were then made to react this compound with sodium cyclopentadienyltricarbonyl molybdenum.

(i) In THF

The reaction was initially attempted in refluxing THF solution but very little reaction occurred over several hours. A yellow hexane soluble carbonyl compound was isolated, but only in sufficient quantity to allow its infrared spectrum to be recorded. The reaction was therefore performed at higher temperatures.

(ii) In Dimethylformamide

A solution of cyclopentadienyl sodium in THF was prepared from sodium sand (0.13 g., 5.65 mmole) and a slight excess of freshly cracked (see Appendix I) cyclopentadiene.  $\text{Mo(CO)}_6$  (1.51 g., 5.6 mmole) was then added and the mixture refluxed overnight. The THF was then removed in vacuo and the white residue dissolved in dimethylformamide.  $\text{Ph}_2\text{C=N-C(Cl)Ph}_2$  (2.15 g., 5.6 mmole) in a 1:1 mixture of toluene and D.M.F. was then added. After 24 hrs. at  $110^\circ$ , during which time very slow gas evolution was observed, the deep brown mixture was evaporated to dryness. Extraction of the residue with hexane gave a brown organic solid, a little  $[\text{CpMo(CO)}_3]_2$  and  $\text{CpMo(CO)}_3\text{Cl}$ . At least one other carbonyl complex was present in small amounts, but attempts to purify it by chromatography and crystallisation were not successful ( $\nu(\text{C-O})$  at 1960 and  $1870\text{ cm}^{-1}$ ).

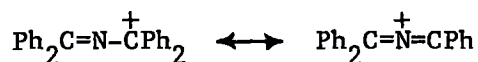
The residue after hexane extraction contained substantial quantities of  $[\text{CpMo(CO)}_3]_2$  which was recrystallised from chloroform and characterised by its infrared spectrum.

(iii) In Diglyme

Using the same quantities of reactants, and a similar procedure, there was evidence for the formation of small quantities of the same complex, but the main product was again  $[\text{CpMo(CO)}_3]_2$ , recovered in 75% yield, and most of the organic chloride was recovered unchanged.

### Conclusions

The pseudo-allyl complex could not be synthesised by this direct method under the conditions studied. The main reaction appears to be decomposition of the sodium salt to  $[\text{CpMo}(\text{CO})_3]_2$ . One possible explanation for the non-formation of the pseudo-allyl complex is as follows. In the analogous reaction between allyl chloride and  $\text{Na}[\text{CpMo}(\text{CO})_3]$ , the ionic "intermediate" is of the form  $\text{R}_2\text{C}=\text{C}(\text{H})-\overset{+}{\text{C}}\text{R}_2$  which cannot readily rearrange. However, the corresponding nitrogen-containing species would be able to delocalise the positive charge on the carbon atom by use of the lone-pair on the nitrogen atom thus forming an allene analogue.



Allenes, however, do not normally form complexes in which all three carbon atoms are bound to the metal. Instead, other kinds of reactions occur (such as coupling or rearrangement reactions) to  $\pi$ -allyl complexes,<sup>300,301</sup> generally, and none of these is likely with this particular system.

2. Reactions of  $\text{Ph}_2\text{C}=\text{NBr}$

a) Reaction with  $\text{Na}[\text{CpMo}(\text{CO})_3]$

(i) In THF solution

N-Bromodiphenylketimine (2 g., 7.8 mmole) in THF was added dropwise to a solution of  $\text{Na}[\text{CpMo}(\text{CO})_3]$  (6.12 mmole in 50 ml. THF). CO was slowly evolved and the solution rapidly became deep red. After 2 hrs, the solvent was removed and the residue extracted with  $\text{CHCl}_3$  (60 ml.). Addition of hexane to this solution caused crystallisation of most of the  $[\text{CpMo}(\text{CO})_3]_2$  present, and the filtered solution was then evaporated to small bulk and chromatographed on Grade II Acid alumina. Elution with a 5:1 mixture of hexane and  $\text{CHCl}_3$  gave first unreacted  $\text{Ph}_2\text{C}=\text{NBr}$  which was followed by the remaining  $[\text{CpMo}(\text{CO})_3]_2$  (80% based on  $\text{Mo}(\text{CO})_6$  used). Elution with a 1:1 mixture of these solvents gave  $\text{CpMo}(\text{CO})_3\text{Br}$  (10% based on  $\text{Mo}(\text{CO})_6$ ) which was recrystallised from toluene and characterised by comparison with an authentic sample, and finally,  $\text{Ph}_2\text{C}=\text{N}-\text{N}=\text{CPh}_2$  in small yield which was characterised by its mass and infrared spectrum.

This reaction was repeated at  $0^\circ\text{C}$ , but the same products were obtained, and there was no indication of the presence of any other carbonyl complex.

(ii) In Toluene

A solution containing 22 mmole  $\text{Ph}_2\text{C}=\text{NBr}$  in toluene was added dropwise to a suspension of an equimolar quantity of  $\text{Na}[\text{CpMo}(\text{CO})_3]$



in toluene. A very rapid exothermic reaction ensued, and the mixture became very dark. The solvent was removed by distillation under vacuum and the products (identical to those above) were separated in the same way.

When the reaction was performed in an ice-salt bath, the same mixture of products was obtained.

Since  $\text{Ph}_2\text{C}=\text{NBr}$  is known to be a good halogenating agent,<sup>286</sup>  $\text{CpMo}(\text{CO})_3\text{Br}$  could be formed from either  $\text{CpMo}(\text{CO})_3\text{Na}$ , or  $[\text{CpMo}(\text{CO})_3]_2$  as it is formed in the reaction. The reaction between  $\text{Ph}_2\text{C}=\text{NBr}$  and  $[\text{CpMo}(\text{CO})_3]_2$  was therefore investigated.

b) Reaction with  $[\text{CpMo}(\text{CO})_3]_2$

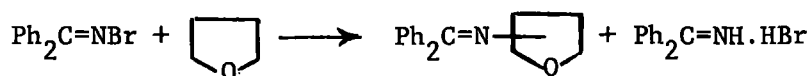
This reaction was initially performed in THF solution and  $\text{CpMo}(\text{CO})_3\text{Br}$  was formed in  $\sim 10\%$  yield. However, there were several reactions apparently occurring simultaneously to give  $\text{Ph}_2\text{C}=\text{NH}_2\text{Br}$  and several other unidentified products. One of these which is probably significant was a black organic uncharacterised material which could be isolated by chromatography. It contained C, H, N and bromine and its infrared spectrum showed several bands in the  $\nu(\text{C}=\text{N})$  region.

The source of hydrogen in the salt  $\text{Ph}_2\text{C}=\text{NH}_2\text{Br}$  was shown to be both the THF and the  $\pi$ -cyclopentadienyl groups as follows

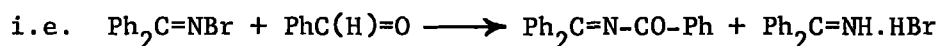
(i) Reaction between  $\text{Ph}_2\text{C}=\text{NBr}$  and THF

The bromoimine was stirred in excess THF at room temperature for

several hours. The white  $\text{Ph}_2\text{C}=\text{NH}_2\text{Br}$  precipitated out after about 20 mins. as the solution slowly went yellow in colour. The  $\text{Ph}_2\text{C}=\text{NH}\cdot\text{HBr}$ , recovered in 46% yield, was filtered off, washed with hexane and characterised by comparison with an authentic sample. The other product of this reaction, a yellow waxy solid was not characterised, but it seems likely that the reaction occurring is of the type



by analogy with the reaction of benzaldehyde,<sup>286</sup> where the hydrobromide salt is also formed in about 50% yield.



(ii) Reaction between  $\text{Ph}_2\text{C}=\text{NBr}$  and  $\pi$ -Cyclopentadienyl compounds

$\text{Ph}_2\text{C}=\text{NBr}$  was stirred with excess ferrocene in toluene for several hours. (The N-bromoimine does not react with toluene at room temperature<sup>286</sup>). The mixture was pumped dry and  $\text{Ph}_2\text{C}=\text{NH}\cdot\text{HBr}$  was isolated by sublimation ( $80-100^\circ$ ,  $10^{-3}$  mm).

With  $[\text{CpMo}(\text{CO})_3]_2$  in toluene, evolution of CO occurred as the solution went black. The precipitated  $\text{Ph}_2\text{C}=\text{NH}\cdot\text{HBr}$  was filtered off, washed with  $\text{CHCl}_3$  and characterised.  $\text{CpMo}(\text{CO})_3\text{Br}$  was detected in the mixture spectroscopically, but was not isolated.

c) Discussion

N-Bromodiphenylketimine may react in at least three different ways;

(a) Heterolytic cleavage of the N-Br bond, which assumes that the polarity of the bond is  $\overset{\delta+}{\text{N}}-\overset{\delta-}{\text{Br}}$

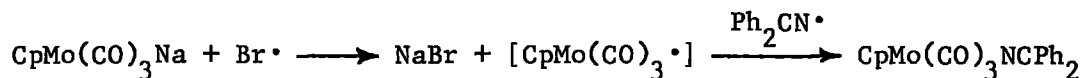
(b) Homolytic cleavage of the N-Br bond with the production of diphenylimine and bromine radicals (i.e.  $\text{Ph}_2\text{C}=\text{N}\cdot$  and  $\text{Br}\cdot$ )

(c) Homolysis of the N-Br bond with the production, in a chain mechanism, of molecular  $\text{Br}_2$ , in the same way that N-bromosuccinimide is believed to react in at least some cases.<sup>287-9</sup>

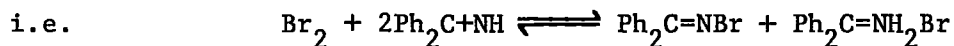
The rapidity of many of the reactions described indicates that a free radical mechanism is probably involved, even when the substrate is a sodium salt. This is further substantiated by the observation that the reaction with  $\text{Na}[\text{CpMo}(\text{CO})_3]$  is extremely fast and exothermic in toluene solution (which would tend to favour the formation of radicals) whereas the same reaction is apparently slower, and certainly not so obviously exothermic, in the more polar THF. This mechanism is also suggested by the lack of the formation of ketimino-molybdenum complexes, whereas  $\text{CpMo}(\text{CO})_3\text{Br}$  (which is unlikely to be formed in an ionic mechanism) is always formed.

The choice between (b) and (c) on this evidence alone is difficult, but (c) is favoured for the following reasons. Firstly, a non-chain reaction (b) should give at least some  $\text{CpMo}(\text{CO})_3\text{NCPH}_2$  by

a sequence of the type

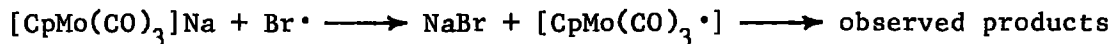


whereas, in fact, none is observed. Secondly the formation of  $\text{Ph}_2\text{C}=\text{NH}_2\text{Br}$  probably indicates a chain mechanism involving  $\text{Br}_2$ , as is believed to be the case in the bromination of organic molecules<sup>276</sup>



(The free imine is formed in one of the chain-propagation steps).

Thirdly, the exothermic nature of the reaction in toluene is characteristic of a chain-reaction. Finally, the presence of a small concentration of  $\text{Br}_2$  which is maintained throughout the reaction (as it would be in a chain-process) would explain the formation of  $[\text{CpMo(CO)}_3]_2$  by oxidation of  $[\text{CpMo(CO)}_3]^-$ , although a chain termination step



is equally likely.

3. Reaction between  $\text{CpMo}(\text{CO})_3\text{Cl}$  and  $\text{Me}_3\text{SiN}=\text{CPh}_2$

$\text{CpMo}(\text{CO})_3\text{Cl}$  (2 g., 7.1 mmole) and an excess of the silylimine (13.8 mmole) were stirred under nitrogen in monoglyme. A darkening in colour, accompanied by slow evolution of carbon monoxide commenced at about  $70^\circ$ , and reaction was shown spectrophotometrically to be complete after 6 hrs. On cooling, small crystals (I) separated (yield 1.8 g.). The mother liquor was evaporated to small bulk in vacuo and hexane added to cause crystallisation of  $[\text{CpMo}(\text{CO})_3]_2$ . This process was repeated until no more of this material was present (total  $[\text{CpMo}(\text{CO})_3]_2$  collected was 0.18 g. i.e. 10% based on  $\text{CpMo}(\text{CO})_3\text{Cl}$ ) and the resulting solution pumped dry. The residue was extracted into 10 ml. toluene and to the filtered, brown solution, hexane (50 ml.) was added. This, on cooling, caused deposition of a brown powder (II) which was reprecipitated from toluene, washed with hexane and pumped dry. (Yield 0.15 g.).

The volatile materials present in the initial reaction mixture were shown to be monoglyme and trimethylchlorosilane only, by comparing their retention times on a vapour-phase chromatograph with those given by an authentic mixture.

a) Characterisation of  $[\pi\text{-C}_5\text{H}_5\text{Mo}(\text{CO})\text{N}:\text{CPh}_2]$  (I)

Properties: I is an air-sensitive green-black crystalline dichroic solid which mulls to a yellow powder, its decomposition product being a green non-carbonyl which is soluble in  $\text{CHCl}_3$ . It is almost insoluble

in hydrocarbons and ethers, but is soluble to a small extent in  $\text{CHCl}_3$  and hot monoglyme, giving yellow-green solutions.

In a melting-point tube it blackens at  $\sim 200^\circ\text{C}$  and finally melts with decomposition at  $315\text{-}317^\circ$ .

Analyses: Data obtained for three separately prepared samples are shown in Table 5-2.

Table 5-2  
Analytical Figures for I

	C	H	N	CO
$\text{C}_{19}\text{H}_{15}\text{MoNO}$ requires	61.8	4.07	3.80	7.6
Obtained	61.7	4.56	4.74	6.6
	61.3	3.95		
	61.5	4.13	4.21	

Infrared Spectrum (Nujol Mull): There is a single, C-O stretching band at  $1860\text{ cm}^{-1}$  (vs), which has a weak shoulder at  $1826\text{ cm}^{-1}$  but no band that can be assigned to  $\nu(\text{C}=\text{N})$ . The other bands and their assignments are shown in Table 5-3.

Table 5-3

Assignment	Position ( $\text{cm}^{-1}$ )
$\text{Ph}_2\text{C}=\text{N}^*$	1600(w), 1471(m), 1449(m), 1160(w), 1075(m), 1031(m), 769(s) 704(vs), 632(s), 750(s, br), 465(s, br), 449(m, br)
$\pi\text{-C}_5\text{H}_5^{**}$	1267(m), 1010(m), 838(m), 804(s)
Unassigned	1108(m), 740(s)

\* By comparison with  $\text{Ph}_2\text{C}=\text{NLi}$

\*\* By comparison with  $\pi\text{-C}_5\text{H}_5\text{Mo}(\text{CO})_3\text{Cl}$

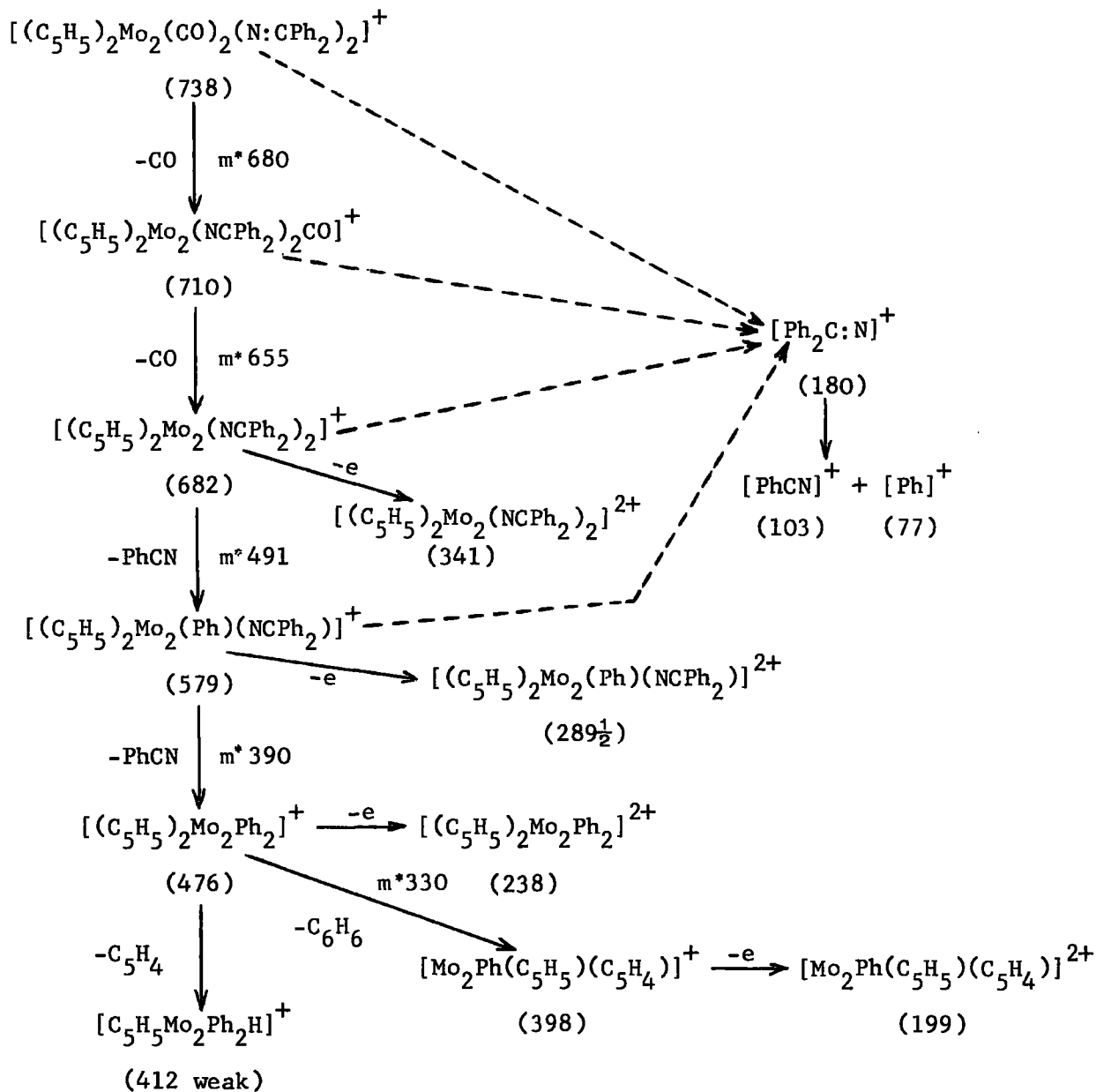
P.M.R. Spectrum: The spectrum in  $\text{CDCl}_3$  solution consists of a sharp singlet at  $5.21\tau$  ( $\pi\text{-C}_5\text{H}_5$ ), <sup>274</sup> and a multiplet centred at  $2.78\tau$  ( $=\text{CPh}_2$ ) in intensity ratio 1:2.

Mass Spectrum: (Direct Insertion Probe at  $220^\circ\text{C}$ ). The parent ion, corresponding to  $[\pi\text{-C}_5\text{H}_5\text{Mo}(\text{CO})\text{NCPPh}_2]_2^+$ , and ions formed in the expected breakdown of this, were all observed, as shown in the scheme in Fig. 5-4. The highest observed monoisotopic species (i.e. organic) corresponds to  $[\text{Ph}_2\text{C}=\text{N}]^+$ , and could arise, as shown by the dotted lines in Fig.5-4, from any of four ions - the most likely being the lower two - and its presence verifies that this group occurs in the complex. The masses of all the ions containing Mo shown in Fig.5-4 are based on  $\text{Mo}_2 = 192$ . This is the most abundant isotope combination (Appendix 4).

The loss of two successive CO groups, followed by two successive PhCN molecules is the primary breakdown path, as proved by the positions of the metastables, but the isotope-distribution patterns for all the ions except  $\text{P}^+$  and  $(\text{P-CO})^+$ , including the doubly charged ones, are more complicated than calculated, and in all cases extend to lower mass than expected. This, as for the pseudoallyl complex described earlier, is a consequence of facile secondary breakdown of the ions, as they are formed, by loss of  $\text{H}^\bullet$  or  $\text{H}_2$ , and occurs for all the species with more than one organic group in close proximity. Indeed, close examination of the pattern for the ion corresponding to

Fig. 5-4

Proposed Fragmentation Scheme for  $[\pi\text{-C}_5\text{H}_5\text{Mo}(\text{CO})\text{N}:\text{CPh}_2]_2^+$





$[(C_5H_5)(C_6H_5)Mo]_2^+$  at about 476 indicates that loss of up to 4 H atoms is occurring since there is a peak at mass 464 which can only arise by loss of 4 hydrogens: i.e. it corresponds to  $\{ [^{92}Mo(C_5H_5)(C_6H_5)]_2 - 4H \}^+$ . The simplest species (at 398 and 412), however, both show the pure  $Mo_2$  isotope pattern, after correction for  $^{13}C$ .

The persistence of  $Mo_2$  species throughout the spectrum - there is no evidence for the production of any mononuclear ions - is in common with the observed behaviour of many polynuclear metal carbonyls; in most cases, the metal-cluster is not broken until all the other groups attached have been lost. <sup>213-5,290.</sup>

Reaction with  $Ph_3P$ : No reaction with triphenylphosphine was observed in refluxing monoglyme. In fact,  $[CpMo(CO)NCPH_2]_2$  was still present even after four days under these conditions.

Reaction with Iodine: Addition of a solution of iodine (0.12 g., 0.035 mmole) in monoglyme to  $[CpMo(CO)N:CPh_2]_2$  (0.35 g., 0.046 mmole) in the same solvent caused elimination of all the carbon monoxide in the compound. Removal of the solvent and extraction with chloroform gave a black solution (which showed no C-O stretching bands in the infrared) from which hexane caused the crystallisation of a very small quantity of shiny, emerald coloured crystals which gave a purple mull. Apart from these crystals, no other compound could be isolated in a pure state. The green/purple complex was only isolated in very small yield, but the mass spectrum (Direct insertion probe; source temperature

275°C) suggests a formulation  $(\pi\text{-C}_5\text{H}_5)_3\text{Mo}_3\text{I}_3\text{O}_4$ , as shown in Table 5-4.

Table 5-4

Mass	Assignment	Mass	Assignment	Mass	Assignment
934*	$\text{Cp}_3\text{Mo}_3\text{I}_3\text{O}_4$	433	$\text{CpMoI}_2\text{O}$	195	$\text{CpMoO}_2$
		355	$\text{Cp}_2\text{MoI}$	179	$\text{CpMoO}$
624†	$\text{Cp}_2\text{Mo}_2\text{I}_2\text{O}_3$	322	$\text{CpMoIO}_2$	163	$\text{CpMoI}$
497	$\text{Cp}_2\text{Mo}_2\text{IO}_3$	306	$\text{CpMoIO}$	128	HI
387	$\text{Cp}_3\text{Mo}_2$	290	$\text{CpMoI}$	127	I
		228	$\text{Cp}_2\text{Mo}$	65 etc.	$\text{C}_5\text{H}_5$ etc.

\*  $\text{Mo}_3 = 294$       †  $\text{Mo}_2 = 192$

The dinuclear species are more abundant with the source temperature at 235°C. The peaks assigned to  $\text{Mo}_3$  and  $\text{Mo}_2$  species all have the correct isotope distribution pattern. Consistent with this formulation, the infrared spectrum shows only (a) bands typical of  $\pi\text{-C}_5\text{H}_5$  groups at 3096(w), 1412(m), 1351(w), 1258(w), 1058(m), 1013(s), 971(m), 845(m), 831(m) and 820(s)  $\text{cm}^{-1}$ . (b) A very strong band at 938  $\text{cm}^{-1}$ , assigned to  $\nu(\text{Mo}=\text{O})$ <sup>291,298</sup> (c) A band of medium intensity at 786  $\text{cm}^{-1}$  tentatively assigned to an Mo-O-Mo bridge vibration.<sup>291,298</sup>

Obtained C, 20.8; H, 1.57%.  $\text{C}_{15}\text{H}_{15}\text{Mo}_3\text{O}_4\text{I}_3$  requires C, 19.4; H, 1.64%.

Attempts to re-isolate this complex in sufficient quantities to

allow a conventional characterisation and further study are in progress, although it must be assumed that the solvent is the source of oxygen in this reaction since CO evolution was observed

b) Product II

As described earlier, a second product is formed in the reaction between  $\text{Ph}_2\text{C}=\text{NSiMe}_3$  and  $\text{CpMo}(\text{CO})_3\text{Cl}$ , and is believed, on the basis of the evidence to be presented, to be the mononuclear ketimino-molybdenum carbonyl complex from which I,  $[\text{CpMo}(\text{CO})\text{NCPH}_2]_2$ , is derived in the course of the reaction. It was only isolated from the reaction mixture on one occasion. Several subsequent attempts to isolate this material were unsuccessful; either the infrared spectrum of the reaction mixture showed that none was present<sup>4</sup>, or, it was present in such small quantities that it could not be isolated in a pure form in sufficient quantity to allow study.

It was a brown powder which was freely soluble in  $\text{CHCl}_3$  and ether, and reasonably soluble in aromatic hydrocarbons. It could not be eluted from either silica or alumina chromatography columns, thus precluding its purification by this technique.

Mass Spectrum: (Direct Insertion at  $200^\circ\text{C}$ ). Again, the technique of mass spectroscopy proved to be the most useful in the attempt to characterise this complex. The heaviest ion in the spectrum corresponds to  $[\text{C}_5\text{H}_5\text{Mo}(\text{CO})_2\text{NCPH}_2]^+$ , and the isotope pattern confirms the presence of only one Mo atom. This ion breaks down, by loss of two

CO groups, to  $[\text{C}_5\text{H}_5\text{MoNCPh}_2]^+$ , which is also observed as a doubly-charged species. Loss of PhCN then occurs, leaving  $[\text{C}_5\text{H}_5\text{MoC}_6\text{H}_5]^+$  as the lowest observed Mo-containing species. The organic ions in the spectrum correspond to  $[\text{Ph}_2\text{C=N}]^+$  (180) and species derived from this (i.e.  $[\text{PhCN}]^+$  (103),  $[\text{PhC}]^+$  (89),  $[\text{PhCH}_{1-3}]^+$  (90-2),  $[\text{Ph}]^+$  (77) etc.).

The spectrum is consistent with a complex in which the  $\text{Ph}_2\text{C=N}$  group is bound terminally, via the nitrogen atom, to molybdenum. It also confirms the presence of two CO groups, although the presence of a third CO group cannot, on this evidence, be ruled out, since there have been several reported cases of  $\text{CpM}(\text{CO})_n$  complexes giving a highest mass at  $[\text{CpM}(\text{CO})_{n-1}]^+$  and no ion corresponding to  $\text{P}^+$ .<sup>214</sup>

Analysis: Only a single analysis, for carbon and hydrogen content, was possible. Obtained; C, 60.6; H, 4.46%.  $\text{CpMo}(\text{CO})_3\text{NCPH}_2$  requires C, 59.4; H, 3.54%;  $\text{CpMo}(\text{CO})_2\text{N:CPh}_2$  requires C, 60.5; H, 3.78%.

Infrared Spectrum: Two strong C-O stretching vibrations were observed at 1920 and 1856  $\text{cm}^{-1}$ , together with a band which is believed to be due to impurity at 1804  $\text{cm}^{-1}$ . There was also a medium band at 1534  $\text{cm}^{-1}$  ( $\nu(\text{C=N})$ ) and numerous other bands assigned to  $\pi\text{-C}_5\text{H}_5$  groups and phenyl groups.

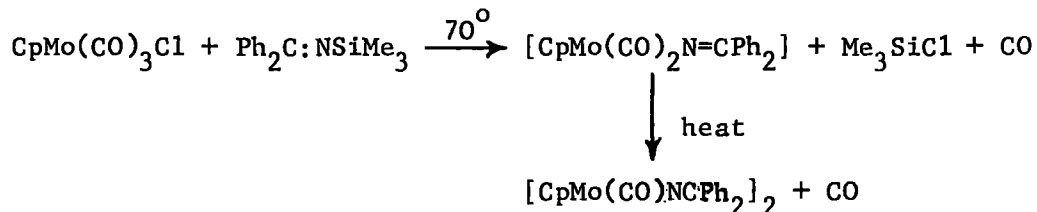
P.M.R. Spectrum: ( $\text{CDCl}_3$  solution). In the region where  $\pi\text{-C}_5\text{H}_5$  groups resonate, two sharp singlets of unequal intensity, separated by 4 c.p.s., were observed (at 5.05 and 5.117 respectively). A multiple due to the phenyl groups (2.48  $\tau$ ) was also observed, the intensity ratio being

2:1, consistent with the presence of one  $\pi\text{-C}_5\text{H}_5$  group and two phenyl groups, but the occurrence of two  $\pi\text{-C}_5\text{H}_5$  resonances is difficult to explain - it may indicate the presence of isomers, or of a mixture.

Thermal Decomposition: In a sublimation apparatus, thermal decomposition rather than sublimation occurred (between 100-150°C). The deep green residue has an infrared spectrum which is identical to that of the dimeric derivative  $[\text{CpMo}(\text{CO})\text{NCPH}_2]_2$ , but also indicated the presence of a further complex which had a C-O stretching band at  $1804\text{ cm}^{-1}$ , identical to the impurity band mentioned earlier. This suggests that the original compound was a mixture and that the mass spectrum was of the more volatile component, but this not consistent with the analytical data, unless the two compounds have similar constitutions.

c) Discussion

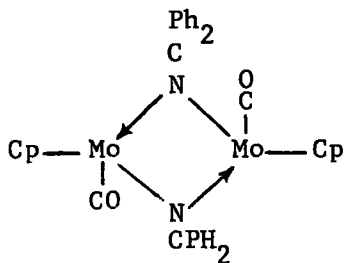
The reaction between  $\text{CpMo}(\text{CO})_3\text{Cl}$  and  $\text{Me}_3\text{SiN=CPh}_2$  gives, in good yield, the dimeric complex  $[\pi\text{-C}_5\text{H}_5\text{Mo}(\text{CO})\text{NCPH}_2]_2$ , which is formed by the thermally initiated dimerisation of a mononuclear complex, apparently of constitution  $[\pi\text{-C}_5\text{H}_5\text{Mo}(\text{CO})_n(\text{N=CPh}_2)]$ , where n is probably 2, as in the scheme below.



The dimerisation to a monocarbonyl by loss of CO is itself suggestive of a dicarbonyl monomer.

This latter derivative was isolated from the reaction mixture on one occasion, and its dimerisation in the solid state observed, although the information obtained about it was insufficient for definitive characterisation. Its existence is mainly postulated on mass-spectroscopic evidence. Further attempts to isolate this complex were unsuccessful, probably because the initial reaction does not occur below the temperature at which dimerisation occurs, and so a detailed discussion of its properties and interpretation of its spectral parameters is not possible. However, this mononuclear intermediate is apparently stable with respect to dimerisation at room temperature, and so this is an indication that a terminally bound  $\text{Ph}_2\text{C}=\text{N}$  group in the cyclopentadienyl molybdenum carbonyl system is more stable than the corresponding mononuclear RS derivatives,<sup>84</sup> which could not be isolated.

The constitution of the dimeric complex is unusual in that the molybdenum atoms in a structure like II would not obey the inert gas

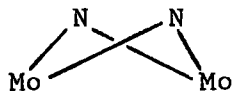


II

rule, since they would only have 16 outer electrons, unless a double metal-metal bond is postulated. The most likely structures for this complex are

(i) The cis-trans pair based on an octahedral arrangement of the ligands about the Mo atoms, where the  $\text{Mo}_2\text{N}_2$  nucleus has to be planar. These are shown in Fig.5-5, where cis- and trans- refer to the relative orientation of the CO (and therefore the Cp) groups. The trans-complex is of  $C_{2h}$  symmetry, and the cis-complex,  $C_{2v}$ .

(ii) Those structures in which the  $\text{Mo}_2\text{N}_2$  ring is puckered, as below, when the presence of one or two bent Mo-Mo bonds would result



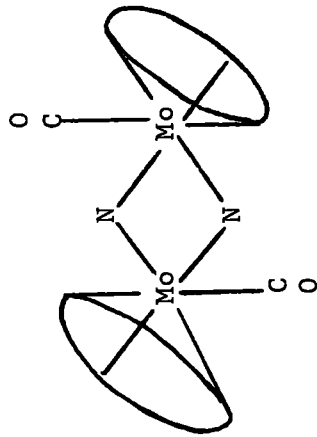
in 7- or 8-"co-ordination" respectively. All the structures of this type are of  $C_{2v}$  or lower symmetry.

The presence of only a single C-O stretching vibration in the infrared spectrum immediately rules out any structure of  $C_{2v}$  or lower symmetry, since two infrared-active C-O stretching modes would be predicted for all of these. It would thus appear that the most likely structure is A (Fig.5-5) in which the two CO groups are on opposite sides of a planar  $\text{Mo}_2\text{N}_2$  ring. If there is very strong interaction between the two metal atoms arising from their tendency to attain the inert gas configuration, the Mo-Mo distance will be shortened and

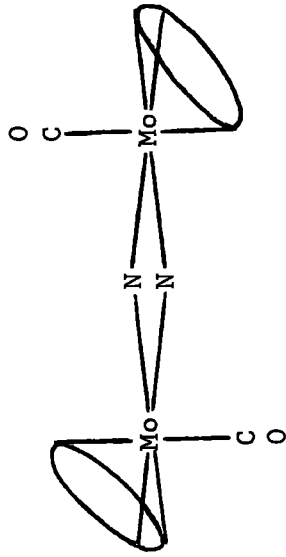
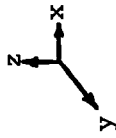
Fig. 5-5

Possible Structures for  $[\pi-C_5H_5Mo(CO)N:CPh_2]_2$  based on Octahedral Molybdenum

(Phenyl groups not shown)

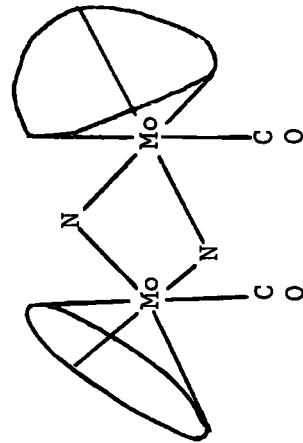


A. Planar-trans. ( $C_{2h}$ )

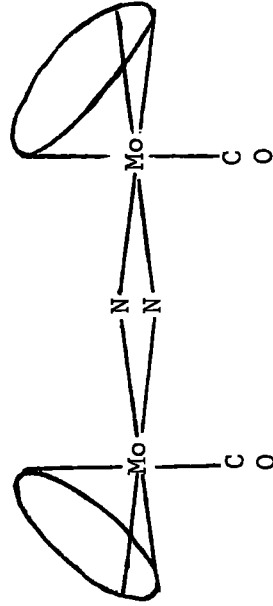


i.e.

A.  $CO = A_g + B_u$  (One active mode- $B_u$ )



B. Planar-cis ( $C_{2v}$ )



i.e.

B.  $CO = A_1 + B_1$  (Two active modes)



both the N-Mo-N angles will be increased above  $90^\circ$ , but this distortion will not change in any way the molecular symmetry, so the group-theoretical prediction of only one infrared-active C-O stretching mode will still apply.

If this structure, based on an octahedral arrangement of the groups about the Mo atoms, is correct, then the  $d_{xz}$  and  $d_{yz}$  orbitals of one Mo atom (see Fig.5-5 for x,y and z directions) are in a position to overlap with the equivalent orbitals of the other metal. The two (Mo-Mo) bonding molecular orbitals thus formed would have  $\pi$ -symmetry and would be bent towards the N atoms. They would therefore be able to overlap with (C-N) $\pi^*$  orbitals with the formation of an extended  $\pi$ -system which would have a marked stabilising effect. The overlap of the orbitals involved in the formation of one of these bonds is shown in Fig.5-6.

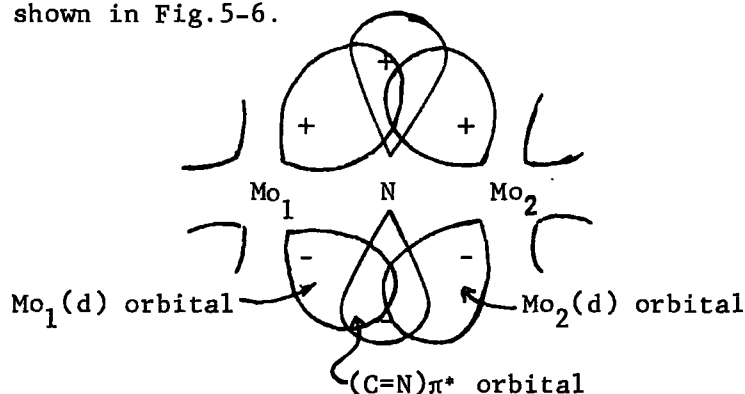


Fig.5-6 Orbitals involved in formation of one (Mo-Mo) $\pi$ -bond

The strong Mo-Mo interaction which is suggested by (a) the thermal stability of the complex, and (b) its dichroic nature, implies, in this

picture, a large reduction in the C-N bond order, as the electron density in  $(C=N)\pi^*$ -orbitals would be high. There would then be a corresponding large decrease in the C=N stretching frequency. For  $Ph_2C=N$  groups bridging between two main-group metal atoms,<sup>268</sup> where this type of  $(d\pi \rightarrow \pi^*)$ -bonding is not possible,  $\nu(C=N)$  is only slightly changed from its value in  $Ph_2C=NH$  itself, and occurs within the range  $1570-1620\text{ cm}^{-1}$ . There is no band in this region of the spectrum of  $[CpMo(CO)NCPPh_2]_2$ , and no band at lower frequency which can be assigned to  $\nu(C=N)$ , suggesting that the C=N stretching modes are inactive (very unlikely) or that their intensity is low so that they cannot be unambiguously detected in the region down to  $1000\text{ cm}^{-1}$  (where  $\nu(C-N)$  occurs<sup>292</sup>) because of the bands due to phenyl or cyclopentadienyl groups.

Other molybdenum complexes are known, whose formal electronic configurations do not conform to the inert gas rule, and double or even triple Mo-Mo bonds have been postulated in these complexes. For example, triple Mo-Mo bonds have been proposed to explain the stoichiometry and apparently unusually strong Mo-Mo interaction in the complexes  $[ArMo(CO)_2]_2$ , where  $Ar = C_9H_9$ <sup>294</sup> or pentamethylcyclopentadienyl,<sup>295</sup> in which the two halves of the molecule are held together only by Mo-Mo bonds. Metal-metal bond orders greater than one are not unusual in other metal-clusters - a quadruple Re-Re bond has been postulated in the  $Re_2X_8^{2-}$  ions.<sup>296</sup>

#### 4. Conclusions

The attempts to synthesise metal carbonyl complexes containing N-bonded diphenylketimino groups have led to some unusual and unexpected products, but they do indicate that such complexes are capable of existence, providing a suitable method of synthesis is adopted and the metal carbonyl system chosen carefully. Both the  $\text{Mn}(\text{CO})_5^-$  and  $\text{CpMo}(\text{CO})_3^-$  systems gave more than one complex containing this group; and both gave monomeric complexes which were unstable, but whose properties suggested that the imino group was terminally bound as a three electron donor. The mononuclear molybdenum complex is unstable with respect to dimerisation, although the C=N stretching frequency indicates that there is some degree of Mo-N bond strengthening by synergic interaction of Mo(d)- and (C-N) $\pi^*$  orbitals, since it occurs some 80-90  $\text{cm}^{-1}$  lower than the corresponding band in  $\text{Ph}_2\text{C=NLi}$  and other ketimino complexes of main group metals.<sup>287</sup>

The difficulties encountered in attempts to prepare complexes containing terminal imino groups is comparable with King's<sup>87</sup> attempts to synthesise derivatives of the isoelectronic arylazo group (R-N=N). He was only able to isolate the molybdenum complex  $\text{CpMo}(\text{CO})_2\text{N=NPh}$ ; the  $\text{Mn}(\text{CO})_5^-$ ,  $\text{Co}(\text{CO})_4^-$ ,  $\text{CpW}(\text{CO})_3^-$ ,  $\text{CpFe}(\text{CO})_2^-$  and  $\text{V}(\text{CO})_6^-$  systems did not give any analogous complexes. This behaviour was explained in terms of a labilising effect on the CO

groups due to the arylazo ligand, which apparently increases the positive charge on the metal and thereby weakens the M-CO bonds, as reflected in the "high" C-O stretching frequencies observed for the single complex isolated (2000 and 1928  $\text{cm}^{-1}$ ). However, these frequencies are lower than those observed for other cyclopentadienyl molybdenum carbonyl complexes which are certainly stable. Thus, the C-O stretching bands for  $\pi\text{-C}_5\text{H}_5\text{Mo}(\text{CO})_3\text{X}$  occur at least 40  $\text{cm}^{-1}$  higher than in these complexes, while in the more directly comparable  $\text{CpMo}(\text{CO})_2\text{NO}$  they occur at 2015 and 1940  $\text{cm}^{-1}$ .

The bridging ketimino ligand appears able to produce a very stable system by virtue of both its strong  $\sigma$ - and  $\pi$ -bonding properties. This is shown by the short Fe-N distance observed in an iron carbonyl complex (Fig.4-2, structure I) and its ability to stabilise a 16-electron molybdenum atom by allowing strong Mo-Mo interaction to occur via the (C-N) $\pi^*$  system. However, the complex  $[\text{CpMo}(\text{CO})\text{NCPH}_2]_2$  is unstable to oxidation (as would be expected, since it is "electron deficient") as shown by its air-sensitivity and immediate reaction with iodine in monoglyme to form an oxo-derivative with liberation of both CO and the imino ligands.

PART II

ANIONIC POLYNUCLEAR CARBONYL DERIVATIVES OF IRON

CHAPTER SIX

Principles of Mossbauer Spectroscopy

## 1. The Mossbauer Effect

Since its discovery by Rudolf L. Mossbauer in 1957,<sup>1,2,3</sup> the Mossbauer effect has been widely used with notable success in Chemistry, Physics and many related fields, often in areas that were previously precluded from experimental investigation. The purpose of this and the next Chapter is to present the important principles of Mossbauer Spectroscopy, and to outline how the effect can be used by chemists to obtain information about structure and bonding in iron carbonyl chemistry. There have been several reviews in the last five years describing in greater detail the applications of the Mossbauer effect in inorganic chemistry.<sup>4-8</sup>

The Mossbauer effect is defined as the recoil-free emission, and subsequent resonant absorption of gamma-rays. The lifetimes of the nuclear excited-states producing Mossbauer gamma-rays are  $10^{-7}$  -  $10^{-10}$  secs, and as a result of the Heisenberg uncertainty principle the resulting gamma-rays have line-widths of  $10^{-7}$  -  $10^{-10}$  eV.<sup>8</sup> An alternative measure of the linewidth is obtained by considering the ratio of the width to the total energy of the gamma-rays used for Mossbauer spectroscopy. These have energies in the range  $10^4$  to  $10^5$  eV, and so their fraction line-widths, as measured, are in the range  $10^{-12}$  to  $10^{-14}$ . This means that gamma-quanta of remarkable precision are produced, e.g. Mossbauer lines are  $\sim 10^9$  times as sharp as a sharp infrared line from a gas. It is this fact which makes gamma-ray resonance such a sensitive method of studying the influence of external factors on

nuclear electric and magnetic properties.

Normally, gamma-rays emitted from a radioactive nucleus cannot be resonantly reabsorbed fully by a similar nucleus for two reasons. Firstly, thermal motion of the nuclei within the source gives rise to Doppler broadening, so that the gamma-rays are not emitted with their natural Heisenberg linewidth. Secondly, since  $\gamma$ -quanta are of high energy, they impart a measurable recoil to the nucleus during emission, so that the energy of the emitted ray is somewhat reduced from its absolute value by that amount producing nuclear recoil. Consequently, the resonance condition is destroyed. Mossbauer's discovery was that if the emitting nuclei are bound in a crystalline lattice at very low temperatures, there is a finite probability that gamma-ray emission will occur without energy loss due to recoil. In such cases the recoil momentum is absorbed by the lattice as a whole and the resulting quantised lattice-vibrational energy is termed the "phonon energy".

However, for a large number of emission events, some will occur without lattice excitation. This fraction of recoil-free or zero-phonon events gives rise to gamma-rays of natural linewidth which possess the full energy of the nuclear transition, and this is the significant principle of the Mossbauer effect, because these rays can now be used to cause resonance with identical nuclei.

Whenever the environment or oxidation state of the emitting nucleus differs from that of the absorber, maximum resonance will not



occur, however, because the differences in energy between the ground state and the excited state of the nuclei will not generally be the same. The energy of the emitted quanta can be changed by utilization of the Doppler effect, and in a Mossbauer resonance experiment, maximum resonance is achieved by moving the source relative to the absorber. In practical terms, these differences in the energy of the nuclear states only amount to about  $10^{-12}$  of the total energy of the  $\gamma$ -quantum, so the relative velocities involved are about  $1 \text{ mm. sec}^{-1}$ .

The Mossbauer effect has been predicted for forty nine elements, but observed for only thirty two so far.<sup>5</sup> There are several properties that a Mossbauer isotope should possess if it is to be used in chemistry.<sup>4-11</sup> The most important of these are listed below.

a) The isotope should be heavy, to reduce recoil effects to a minimum (Potassium is the lightest element for which the effect has been observed).

b) The energy of the first excited state should be fairly low, i.e.  $E_\gamma < 100 \text{ KeV}$ , again to reduce recoil effects.

c) The first excited state should have a suitable half-life ( $\tau_{\frac{1}{2}}$ ) so that the resulting line is neither too broad nor too narrow (The optimum half-life is  $\sim 10^{-7}$  secs).

d) The nuclear cross section for resonance ( $\sigma_0$ ) should be high and the internal conversion coefficient ( $\alpha$ ) low (i.e. minimal interaction between emitted  $\gamma$ -quanta and extra-nuclear electrons, which would change  $E_\gamma$ ).

e) Nuclear spin states should not be too complex; otherwise very complicated spectra will arise.

Finally for convenience, the natural abundance of the radioactive precursor to the Mossbauer isotope should have a high natural abundance (a) and a long half-life ( $T_{\frac{1}{2}}$ ).

These factors substantially reduce the number of elements for which useful chemical information can be obtained. Of these, iron, tin, europium, xenon, gold and tellurium have been studied, but ruthenium, iodine, tungsten and iridium are the most likely additional elements to be studied in the near future.

The Mossbauer study forming part of this thesis is concerned only with iron. Excited  $Fe^{57}$  nuclei are formed in the decay scheme of  $Co^{57}$ , which is shown in Fig.6-1.

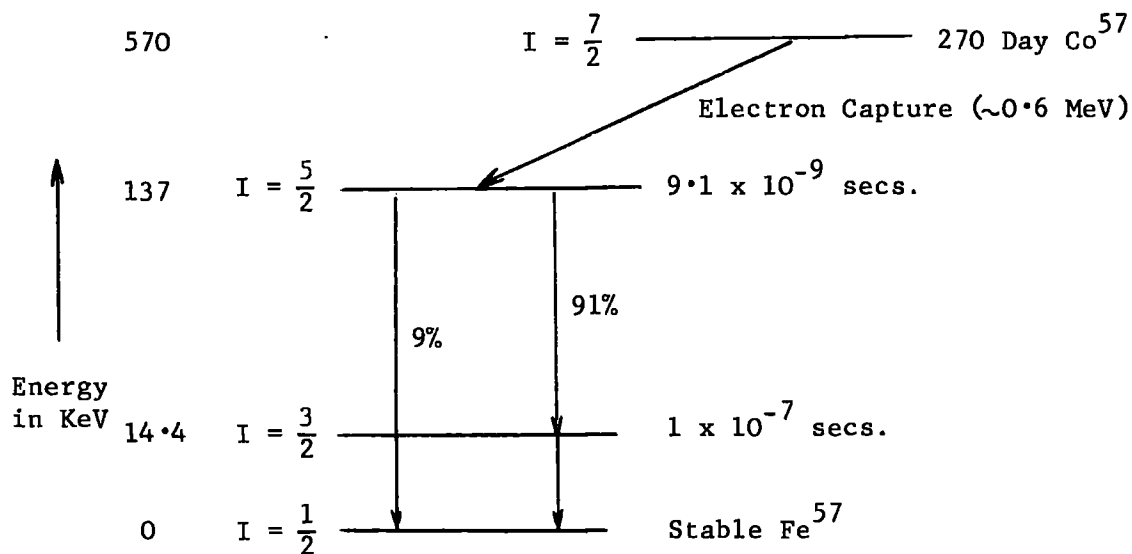


Fig.6-1 Scheme for the Decay of  $Co^{57}$  to  $Fe^{57}$

As can be seen, besides the 14.4 KeV gamma-ray, there are two other high-energy gamma-rays present (137 and 122.6 KeV), and there is also a 7 KeV X-ray resulting from internal conversion. These unwanted rays are removed by filters, or by pulse-height selection (see Chapter 8).

A Mossbauer spectrum is a plot of the number of gamma-rays passing through the absorber versus the velocity of the source relative to the absorber. The four important characteristics of a Mossbauer spectrum are:

- a) The number of peaks
- b) The positions of the peaks along the velocity scale
- c) The shape of the peaks
- d) The intensity of the peaks

Several peaks in a spectrum can be caused by resonant nuclei in different environments in the absorber. Another possibility is that a non-zero electric field gradient (e.f.g.) at the nucleus is interacting with a nuclear quadrupole moment, thus giving rise to "quadrupole splitting", and therefore more than one peak. The nuclear levels can also be split by interactions with internal or external magnetic

fields (Magnetic hyperfine coupling).

The position of the peaks along the velocity scale is a measure of the isomer shift, which is a direct measure of the s-electron density at the nucleus.

The shape of the peaks, c), does not provide a great deal of information, unless there is a suggestion of unresolved splitting or overlap, in which case normal curve-resolving techniques can be applied as in any other branch of spectroscopy. The intensity of the peaks, d), is used, for the purpose of this thesis, to give estimates of the numbers of different kinds of iron species in the compounds studied. To a first approximation, the number of atom in different environments, and the intensities of the resulting Mossbauer lines are linearly related.

The quantities and interactions mentioned above will now be discussed in more detail.

## 2. The Isomer (or Chemical) Shift, $\delta$ .

As outlined above, if the atoms in the absorber exist in a different state of chemical combination from that of the atoms of the radiation source, then it is necessary, to ensure maximum resonance, to move the absorber relative to the source in order to change the energy of the  $\gamma$ -quanta. Therefore, the transition energy of the absorber relative to that of the source nucleus is indicated by the

corresponding source velocity. These values of velocity are called the isomer shift, and are given the symbol  $\delta$  when related to a standard compound (usually sodium nitroprusside).

The isomer shift arises because the nucleus has a finite size. The potential energy of a nucleus surrounded by electronic charge would be a minimum for a point nucleus, but is greater for a nucleus of finite size because of the greater interaction with the electronic charge. Therefore, the greater the dimensions of the excited-state nucleus compared with the ground-state nucleus, the greater will be the energy of transition. The potential energy of the system is also increased by an increase in the electronic charge at or very near to the nucleus. Only s-electrons have a finite probability at the nucleus, so the s-electron density at the nucleus is of great importance. Other electrons, such as p- and d-electrons, while having no probability at the nucleus, have to be considered, however, since they shield the s-electrons from the nucleus to a greater or lesser extent.

The expression<sup>11</sup> which relates the isomer shift to the s-electron density at the nucleus, and the change in the nuclear radius is

$$6-1 \text{ ----} \quad \delta = \frac{4}{5} \pi R^2 e^2 \left( \frac{\Delta R}{R} \right) \left\{ [\psi_s(0)]_{\text{absorber}}^2 - [\psi_s(0)]_{\text{source}}^2 \right\}$$

where  $R$  = radius of the ground-state nucleus

$e$  = charge on an electron

$\Delta R$  = change of the nuclear radius on excitation (i.e.  $R_{ex} - R_{gr}$ )  
 $[\psi_s(0)]^2$  = s-electron density at the nucleus.

It is based on the premise that when a source and absorber are chemically different, then the s-electron density at the nucleus  $[\psi_s(0)]^2$  will be different for the two nuclei both in their excited and ground states as represented diagrammatically in Fig.6-2

6-2 ----  $\delta = [E_{ex} - E_{gr}]_{\text{absorber}} - [E_{ex} - E_{gr}]_{\text{source}}$

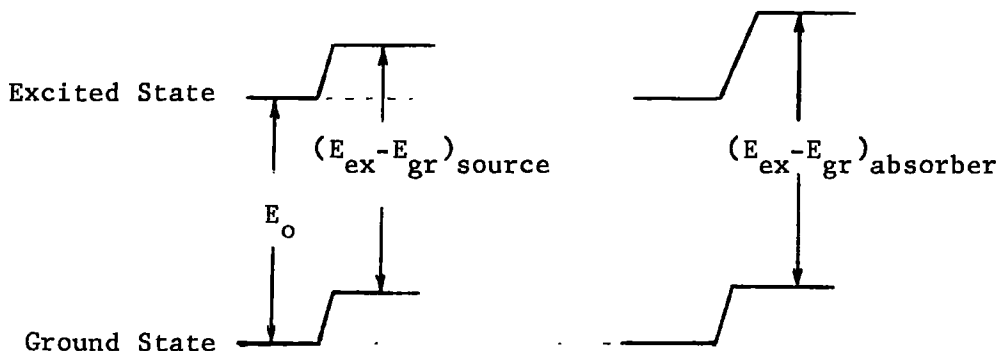


Fig.6-2 Origin of Isomer Shift.

( $E_0$  shows the  $\gamma$ -transition energy expected for point nuclei)

From 6-1 we see that  $\delta$  is directly related to the difference in the s-electron density between the absorber and the source, and to the ratio  $\frac{\Delta R}{R}$ . If  $\frac{\Delta R}{R} = 0$ , i.e. the ground and excited state radii are

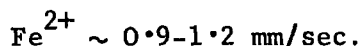
the same, then no isomer shift can be observed, thus precluding any chemical applications of the Mossbauer effect. Using this equation it is possible to deduce the sign of the quantity  $\frac{\Delta R}{R}$  by comparison of chemical shifts for several absorbers, providing more usual chemical considerations unambiguously give the order of s-electron densities for the compounds studied. This procedure indicates that the excited state for Fe is smaller in physical extent than the ground state (i.e.  $\frac{\Delta R}{R} < 0$ ).

The principle factors affecting the s-electron density in the region of the nucleus are:

- a) The oxidation state of the iron atom
- b) The type of bonding in which the atom is involved
- c) The nature of the groups to which it is bonded
- d) External factors, such as temperature and pressure.

Once the sign of  $\frac{\Delta R}{R}$  has been decided, very detailed information about bonding in different kinds of complexes, shielding effects of non-s electrons in different valence states, and numerous other kinds of information can be derived.<sup>8,9</sup>

For the purpose of this thesis, it is sufficient to state that iron atoms in different oxidation states have characteristic isomer shifts, which will be used to identify or confirm the oxidation state present. Some typical ranges are given below.<sup>4</sup>



$$\text{Fe}^{3+} \sim 0.01 \text{ mm/sec.}$$

In coordination complexes and compounds of iron in low valence states, the range is  $-0.6$  to  $+0.6$  mm/sec, and is practically independent of oxidation state and coordination number, although there are certain well defined trends here too.

## 2. Quadrupole Splitting ( $\Delta$ )

It is often found that a spectrum consists of not one, but two lines, even if all the atoms in the absorber are in identical environments. This arises from quadrupole splitting as follows. For nuclei with a spin quantum number  $I \geq 1$ , the charge distribution in the nucleus is not spherically symmetrical, and the nucleus is said to possess a quadrupole moment.<sup>10</sup> If the electric field gradient (e.f.g.) at this nucleus is non-zero, then the interaction between the quadrupole moment and the e.f.g. has the effect of reducing the  $(2I + 1)$ -fold degeneracy of the nuclear levels. If the spin,  $I$  is 0 or  $\frac{1}{2}$ , the nuclear charge is spherically symmetrical and the nucleus cannot have a nuclear quadrupole moment. These principles apply both to the ground and excited nuclear levels.

For  $\text{Fe}^{57}$ , the excited state has  $I = \frac{3}{2}$ , so there are four degenerate levels corresponding to the nuclear magnetic quantum numbers,  $M_I = \frac{3}{2}, \frac{1}{2}, -\frac{1}{2}, -\frac{3}{2}$ . Under the influence of an e.f.g. part of the degeneracy of these four levels is lifted, but those states whose  $M_I$  values differ in



spin only remain degenerate,<sup>11</sup> so there will be two degenerate pairs corresponding to  $M_I = \pm \frac{3}{2}$  and  $\pm \frac{1}{2}$  respectively. For the ground state,  $I = \frac{1}{2}$ , so the two levels  $M_I = \pm \frac{1}{2}$  remain degenerate when under the influence of an e.f.g. Thus, for  $\text{Fe}^{57}$  it is possible to have transitions between the ground state and each of the two components of the excited state. This is represented in Fig.6-3

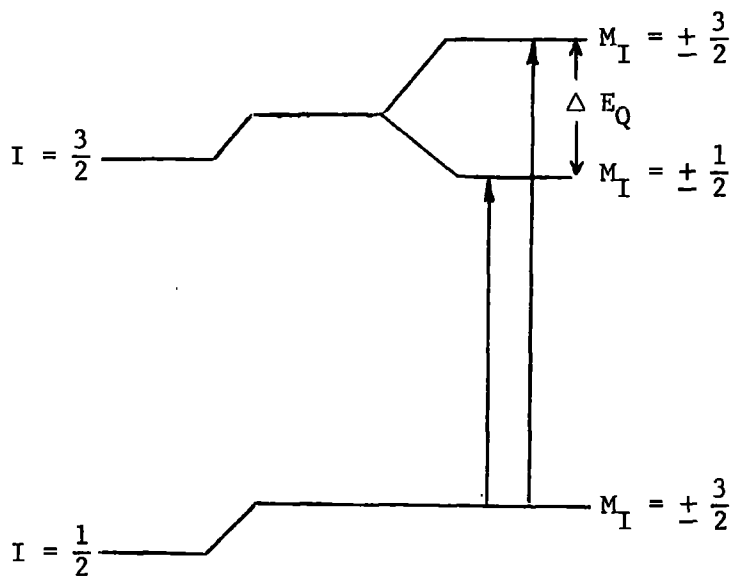


Fig.6-3 Schematic Representation of Quadrupole Splitting.

The quantity  $\Delta E_Q$  is known as the quadrupole splitting and depends on the e.f.g. at the nucleus as described. An e.f.g. arises in part from an unsymmetrical arrangement of distant charges around the nucleus. Cubic arrangements (i.e. Octahedral or tetrahedral) will not generate

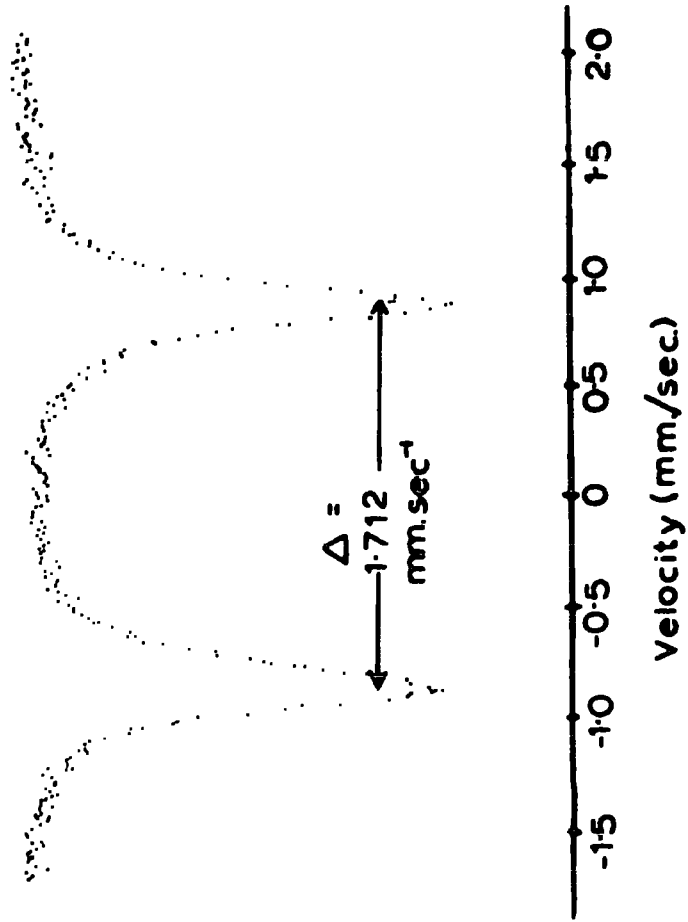
an e.f.g. The other factor contributing to the e.f.g. is the field gradient which arises when electrons are in incomplete shells of the atom itself. This latter effect will give rise to greater e.f.g.'s because of the closer proximity of this electronic charge to the nucleus, compared to that arising from ligand atoms.

One further aspect of quadrupole splitting which must be mentioned is the "Goldanskii Effect".<sup>12</sup> This concerns the probability of Mossbauer transitions in crystals in which there is an axially symmetric e.f.g. at an angle to the direction of the  $\gamma$ -radiation. In single crystals which show this kind of Mossbauer anisotropy, the probabilities of the transitions to the two upper states are not normally equal, so that the intensities of the two lines are unequal. (The ratio of the intensities can vary from 1:1 to 3:1 depending on the angles)<sup>11</sup>. For the purposes of the work to be described in chapter 9, in which relative intensities and quadrupole splittings are very important, the effect imposes the practical criterion that the samples should be in the form of powders, or at least very finely ground microcrystals, so that random orientation of the crystals will nullify the Goldanskii Effect. Then all quadrupolar split pairs are observed as equally intense lines.

Where quadrupole splitting occurs, the isomer shift is measured from the centroid of the two peaks. Fig.6-4 shows a spectrum of sodium nitroprusside to illustrate quadrupole splitting.

FIG. 6-4.

Mössbauer Spectrum of  
Sodium Nitroprusside.



4. Magnetic Hyperfine Coupling:

This effect, which is also called the nuclear Zeeman effect, arises from the interaction between the nuclear magnetic dipole moments of the ground and excited states and a magnetic field. As described above, the nuclear levels are  $(2I + 1)$ -fold degenerate, and under the influence of a magnetic field these are split without the restrictions required for splittings in an electric field. For iron, the ground state splits into two levels (since  $I = \frac{1}{2}$ ) whose nuclear magnetic quantum numbers ( $M_I$ ) are  $+\frac{1}{2}$  and  $-\frac{1}{2}$ , and the excited state ( $I = \frac{3}{2}$ ) into four levels defined by  $M_I = -\frac{3}{2}, -\frac{1}{2}, +\frac{1}{2}, +\frac{3}{2}$ . Consequently, there are eight possible transitions between the ground and excited states, but since the selection rule<sup>11</sup> ( $\Delta M_I = 0, \pm 1$ ) forbids two of these, the spectrum will consist of six lines, as shown in Fig.6-5.

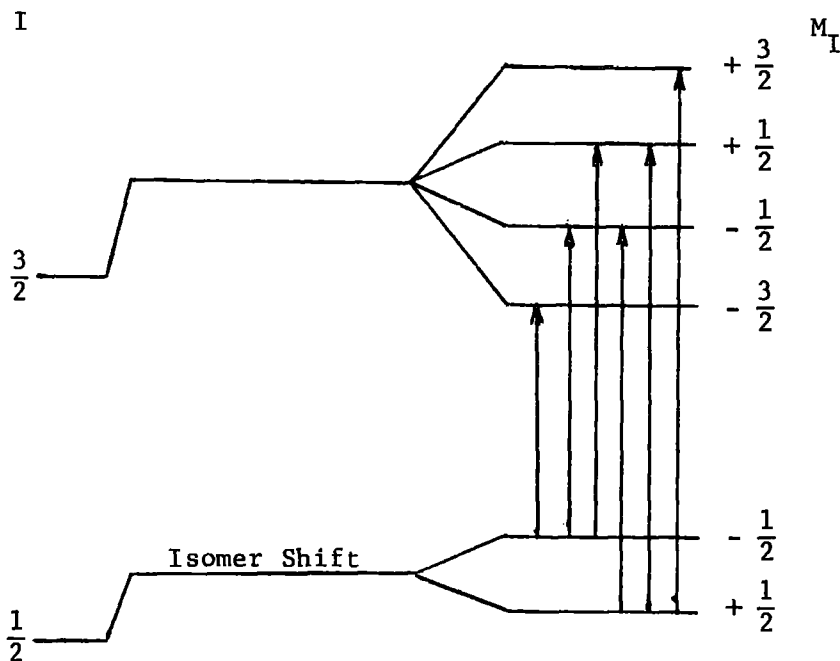


Fig.6-5 Magnetic Dipole Splitting for  $Fe^{57}$ .

In conventional nuclear magnetic resonance only transitions within different  $M_I$  levels of the ground state are observed (i.e. between adjacent magnetic sub-levels of the same nuclear level). However, in the Mossbauer effect, gamma-ray transitions are observed between two nuclear levels, both of which (generally) exhibit magnetic hyperfine splitting.

The six lines for  $\text{Fe}^{57}$  extend over  $\sim 2.0 \text{ mm. sec}^{-1}$ , but they are not of equal intensity, the ratio of their intensities being 3:2:1:1:2:3. This is a consequence of the fact that the selection rule  $\Delta M_I = 0, \pm 1$  only applies together with an angular dependence selection rule, the latter depending on the multipolarity of the  $\gamma$ -radiation (see ref.11).

In the last year, it has become standard practice to quote Mossbauer parameters for iron relative to those observed for sodium nitroprusside. Prior to 1967, the values were often quoted relative to some other iron species, usually the source. Where this is the case in the following discussion, the reference material will be quoted.<sup>7</sup>

CHAPTER SEVEN

The Application of the Mossbauer Effect to Iron Carbonyl Chemistry

The technique of Mossbauer spectroscopy has been used to solve, or give useful information about many structural and bonding problems in the carbonyl and organometallic chemistry of iron. However, at this stage in the development of the technique, it is not possible to give a unique interpretation of the data. In fact, in a few cases the results have been interpreted wrongly, so Mossbauer data should be considered along with other structural data, when this is practicable. Thus, the method is not definitive in itself, but can often unambiguously show that a proposed structure is incorrect. A particularly notorious example of this ambiguity of interpretation concerning the structure of  $\text{Fe}_3(\text{CO})_{12}$ , will be discussed later.

### 1. The Binary Carbonyls

The spectrum of  $\text{Fe}(\text{CO})_5$  consists of a symmetrical pair of lines (i.e. a quadrupole split line) for which  $\delta = -0.447 \pm 0.008 \text{ mm. sec}^{-1}$  and  $\Delta = 2.530 \pm 0.008 \text{ mm. sec}^{-1}$  relative to  $\text{Co}^{57}$  at  $-133^\circ\text{C}$ .<sup>17</sup> These values are consistent with the trigonal bipyramidal structure<sup>56</sup> of  $\text{Fe}(\text{CO})_5$ ; the large quadrupole splitting ( $\Delta$ ) arising from the large electric field gradient expected at the iron nucleus in such a structure. Phosphine substituted iron carbonyl complexes which also have a trigonal bipyramidal structure have values of  $\Delta$  2.4-2.6  $\text{mm. sec}^{-1}$ .<sup>28</sup>

The Mossbauer spectrum of  $\text{Fe}_2(\text{CO})_9$  has been described as an asymmetric doublet.<sup>16,17,18</sup> The small quadrupole splitting,  $0.425 \pm 0.014 \text{ mm. sec}^{-1}$ ,<sup>9</sup> indicates a near octahedral environment for each iron

atom, which is consistent with the X-ray study of Powell and Ewans.<sup>19</sup> The isomer shift ( $-0.420 \pm 0.015$  mm.sec<sup>-1</sup> relative to Co<sup>57</sup>)<sup>17</sup> is low, consistent with the type of bonding expected in this compound, but is less negative than for Fe(CO)<sub>5</sub>. This implies that the extra CO group produces a decrease in the s-electron density at the iron atom (since the  $\frac{\Delta R}{R}$  term in Eq.6-1 is negative). In view of the ability of the CO ligand to remove non-bonding d-electrons from the metal by formation of  $\pi$ -bonds, this is rather surprising, as the extra CO group would be expected to cause an increase in the s-electron density at the nucleus with consequent decrease in isomer shift. Herber<sup>17</sup> suggests that the three bridging CO groups mutually interact to give rise to a ferrocenoid-type of bonding, which would give a reduced s-electron density at the nucleus. The normally accepted bonding scheme for Fe<sub>2</sub>(CO)<sub>9</sub> requires a direct metal-metal bond to account for the diamagnetism of the compound and the short Fe-Fe distance observed in the X-ray study of Powell and Ewans.<sup>18</sup> Orgel<sup>27</sup> has made the point that this diamagnetism may, in fact, be a result of weak, indirect coupling of the unpaired spins, as might be effected through the carbonyl bridges, and Neuwirth<sup>4</sup> suggested that the Mossbauer results support such a mechanism.

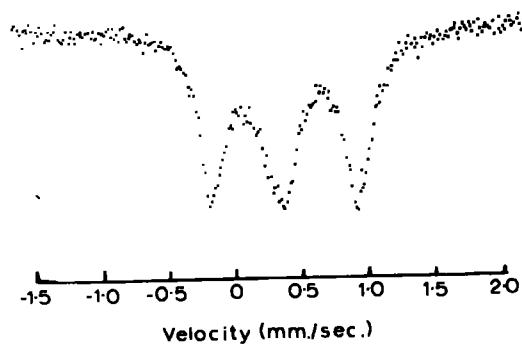
The non-symmetrical nature of the spectrum of Fe<sub>2</sub>(CO)<sub>9</sub> has been the subject of much discussion,<sup>17,18,9</sup> and has variously been attributed to one or more of the following possibilities.



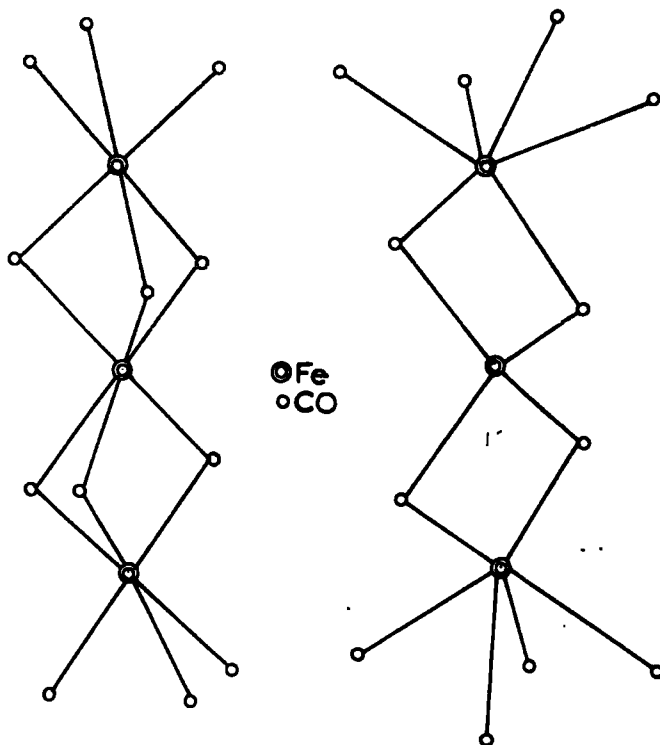
- 1) The presence of two different iron environments, each giving an independent resonance.
  - 2) The presence of an iron-containing impurity, whose single-line spectrum overlaps one of the component peaks in the spectrum of  $\text{Fe}_2(\text{CO})_9$ .
  - 3) Quadrupole splitting coupled with partial orientation of the crystals.
  - 4) Anisotropy of the recoil-free fraction - i.e. the Godanskii Effect.
  - 5) Fluctuation of the environment about the iron atoms.
- Greenwood et al.<sup>16</sup> have shown recently that the asymmetry is due only to crystal orientation. By grinding the sample with an abrasive material (alumina), they were able to obtain a spectrum consisting of a symmetrical pair of peaks whose intensities were independent of the angle of incidence of the  $\gamma$ -radiation.

The spectrum of  $\text{Fe}_3(\text{CO})_{12}$  consists of three, equally intense lines,<sup>17</sup> (Fig.7-1) the central one being slightly broader than the outer pair. A symmetrical triangular structure as originally proposed by Dahl and Rundle<sup>20,21</sup> is ruled out because three equivalent iron atoms would give rise to a single quadrupolar split pair of lines. On the basis of the Mossbauer spectrum, therefore, two different linear structures were proposed by Herber<sup>17</sup> and Fluck<sup>18</sup> (I and II). Herber proposed that the 3:3:3:3 structure would produce the observed

FIG. 7-1.  
Mössbauer Spectrum of  
 $\text{Fe}_3(\text{CO})_{12}$ .



Structures proposed for  $\text{Fe}_3(\text{CO})_{12}$



spectrum as follows. The central iron atom, being in a very nearly octahedral environment, would give rise to the central peak which would show little, if any, quadrupole splitting. The two equivalent outer iron atoms would give a quadrupole doublet because three CO groups are terminally bound, and three are bridging (i.e. the atoms are in a non-cubic environment). This structure is, however, unlikely because the quadrupole splitting of the outer lines ( 1.09) would be expected to be very similar, if not identical to that observed for  $\text{Fe}_2(\text{CO})_9$ , since the environments of relevant iron atoms in the two compounds would be the same. In practice, it is found that  $\Delta[\text{Fe}_3(\text{CO})_{12}]$  is more than twice  $\Delta[\text{Fe}_2(\text{CO})_9]$ . Fluck, in proposing a 4:2:2:4 structure (which would give rise to the same kind of spectrum) argued that the 3:3:3:3 structure would not explain the diamagnetism of the compound without the presence of a metal-metal bond which would then destroy the cubic environment of the central iron atom.<sup>18</sup>

Erickson and Fairhall<sup>22</sup> later carried out Mossbauer studies on the related  $[\text{Fe}_3(\text{CO})_{11}\text{H}]^-$  ion, which has a very similar spectrum to that of  $\text{Fe}_3(\text{CO})_{12}$ , and they were able to deduce that both are triangular, but not symmetrical. This is now known to be the correct interpretation as Dahl and co-workers have since published the molecular structure of  $\text{Fe}_3(\text{CO})_{12}$ <sup>23</sup> and of  $[\text{Fe}_3(\text{CO})_{11}\text{H}]^-$ .<sup>24</sup> These structures are shown diagrammatically in Fig.7-2.

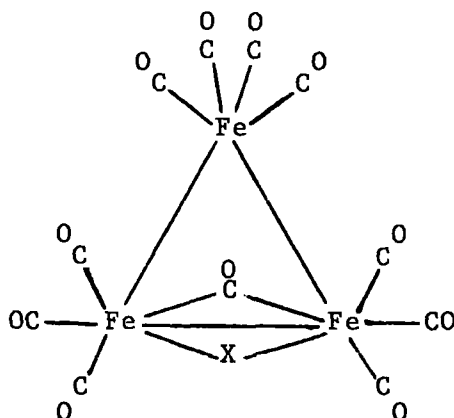


Fig.7-2 Structures of  $\text{Fe}_3(\text{CO})_{12}$  ( $\text{X} = \text{CO}$ ) and  $[\text{Fe}_3(\text{CO})_{11}\text{H}]^-$  ( $\text{X} = \text{H}$ )

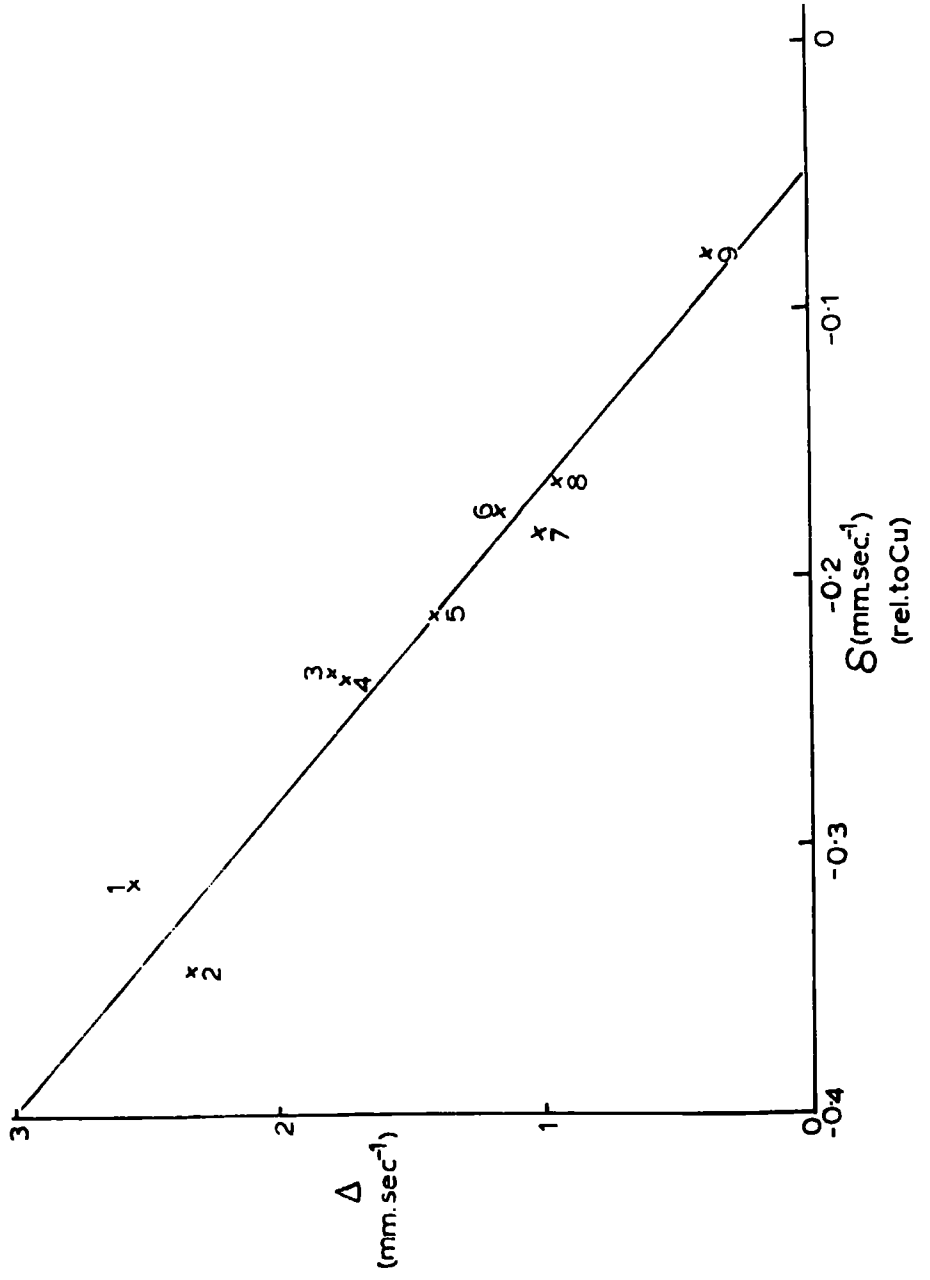
## 2. Substituted Iron Carbonyls

Collins and Pettit<sup>25</sup> studied a series of substituted iron tetracarbonyls of the type  $\text{Fe}(\text{CO})_4\text{R}$ , where R is triphenylphosphine, (1), triethylphosphite (2), acenaphthalene (3), trans-cinnamaldehyde (4), maleicanhydride (5), syn-syn-1,3-dimethyl- $\pi$ -allyl cation (6), the syn-1-methyl- $\pi$ -allyl cation (7), and the  $\pi$ -allyl cation (8). They observed a linear relationship between isomer shift and quadrupole splitting as shown in Fig.7-3. The isomer shift increases and the quadrupole splitting decreases regularly through the series, and they explain the trends as follows.

Since all the ligands are Lewis bases, they donate electrons into hybrid orbitals on the iron atom that will have some 4s-character.

FIG. 7-3.

Quadrupole Splitting vs Isomer Shift for some  $\text{Fe}(\text{CO})_4$  complexes.



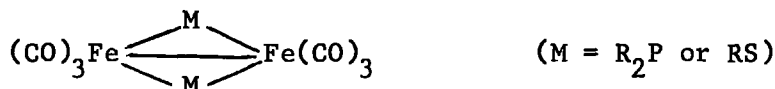
This 'forward co-ordination' thereby increases the s-electron density by formation of  $\sigma$ -bonds. The filled metal orbitals of appropriate symmetry will tend to form partial  $\pi$ -bonds with empty orbitals on the ligand to increase the stability of the system (synergic interaction). This 'back donation', which involves metal 3d orbitals lessens the shielding of the s-electrons on the iron, so the s-electron density increases in this case also. Both factors will therefore lead to an isomer shift to the left in Fig.7-3 (as  $\frac{\Delta R}{R}$  is -ve for Fe).

The Lewis basicity of the ligands decreases in the order they are written above, and if this is the predominant factor, the isomer shift would be expected to increase (i.e. become more positive) for the series as written. The extent of back-donation, on the other hand, increases from triphenylphosphine to the  $\pi$ -allyl cation, so the correlation would be reversed (i.e.  $\text{Ph}_3\text{P}$  producing the most positive  $\delta$ -value) if this were the dominant effect. The results, shown in Fig.7-3, show that Lewis basicity is the more important factor.

The changes in quadrupole splitting can be readily interpreted as showing that the asymmetry of the e.f.g. is enhanced by the localisation of electronic charge between the ligand and iron.

These results then, show that ligands which form strong  $\sigma$ -bonds increase the s-electron density at iron and so decrease the isomer shift, while the resulting concentration of charge adds to the e.f.g. and increases the quadrupole splitting.

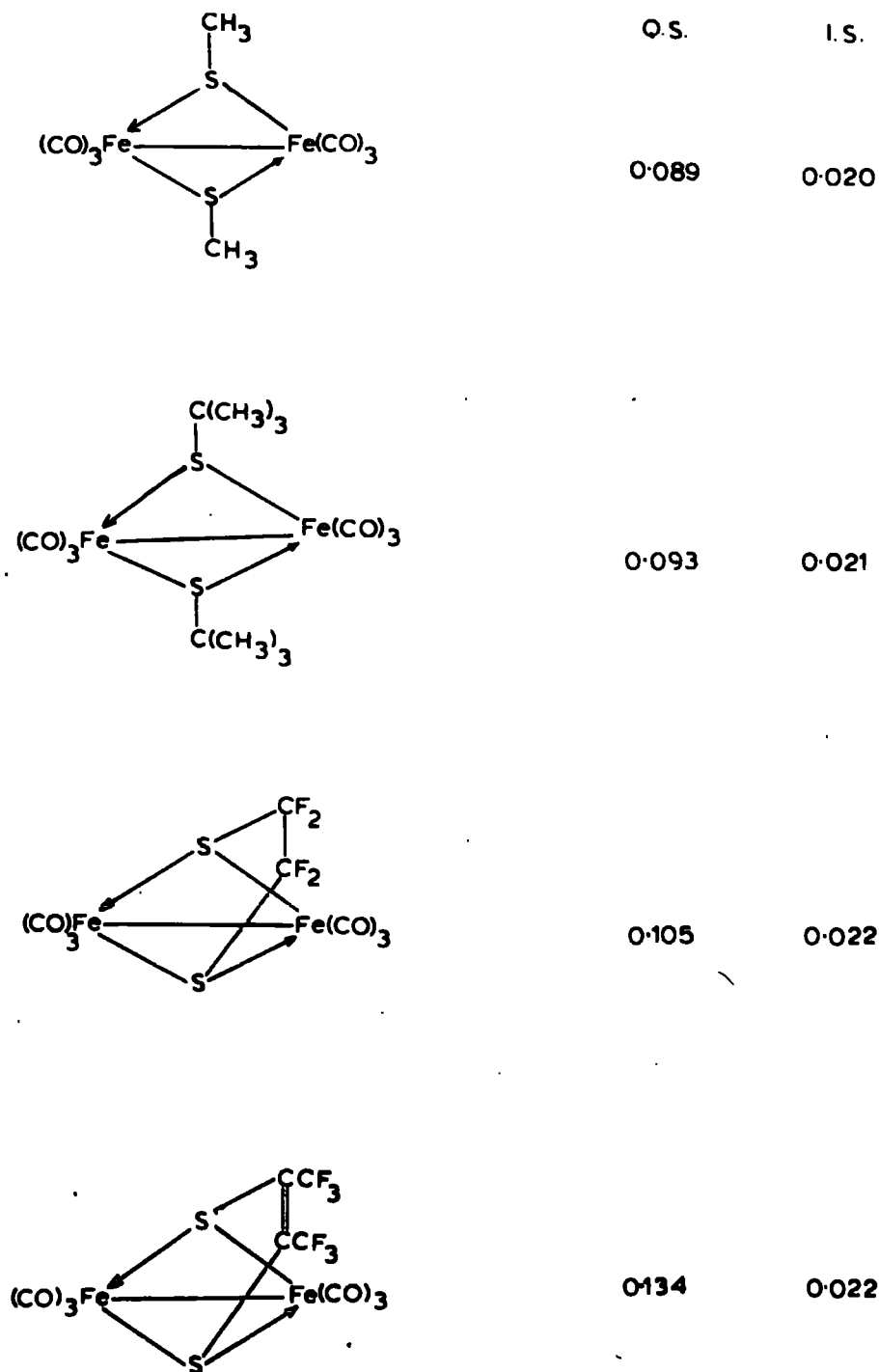
More recently, Greenwood et al.<sup>28</sup> have reported their results for a range of sulphur and phosphorus bridged dimeric carbonyls of the type



and the catenary complex  $(\text{CO})_4\text{Fe} \cdot \text{PMe}_2 \cdot \text{PMe}_2 \cdot \text{Fe}(\text{CO})_4$ . The Mossbauer parameters are rather insensitive both to substitution of CO by  $\text{Et}_3\text{P}$ , and to substitution of R groups in the bridging units. This latter observation is not unexpected since the changes are two or more atoms distant from the Fe atom, but the implication of the former observation, that CO and  $\text{PEt}_3$  ligands have almost identical effects on both the s-electron density and the electrical asymmetry is not explained, although the same effect has been noted before.<sup>25</sup> The correlations that were derived between quadrupole splitting and isomer shift values showed clearly how Mossbauer spectroscopy affords a means of distinguishing between penta- and hexa-co-ordinate iron, and by implication between bridged and catenary complexes;<sup>28</sup> a bent metal-metal bond is required in the structure of the bridged complexes not only to account for their diamagnetism, but also to complete the slightly distorted octahedral environment of the iron atoms, as implied by the low  $\Delta$ -values observed. Much larger effects on Mossbauer parameters were observed for cyclopentadienyl analogues of these

FIG. 7-4

Illustration of dependence of quadrupole splitting  
on molecular distortion.





compounds, showing that this group dominates in determining the electric field gradient. Finally, a comparison between S- and P-bridged complexes suggests that the sulphur atom is a less effective  $\sigma$ -donor than phosphorus in these complexes, although a detailed interpretation of the factors responsible for this was not possible.

Herber, King and Wertheim,<sup>26</sup> give a striking example of the systematic variation of quadrupole splitting with molecular distortion. Isomer shift values for the four compounds shown in Fig.7-4 differ insignificantly, indicating that the electronic structures are very similar, but the quadrupole splitting is increased when the two side chains on the sulphur atoms are linked by a C-C bond, and increased even more when they are linked by a shorter C=C bond.

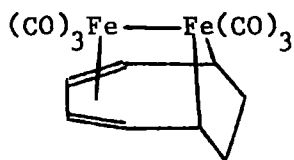
### 3. Olefin-Substituted Carbonyls and Related Compounds.

Several different kinds of olefin-iron carbonyl compounds have been studied, and some useful conclusions regarding the bonding in these systems derived. One of the first uses of the Mossbauer effect in iron carbonyl chemistry was the investigation by Wertheim and Herber<sup>30</sup> of the structure of the two cyclo-octatetraene complexes  $C_8H_8Fe(CO)_3$  and  $C_8H_8[Fe(CO)_3]_2$ . Their results were consistent with a quasi-octahedral arrangement of three CO groups and three of eight C-C bonds around the iron atom, as shown by Lipscomb's<sup>31</sup> X-ray work. Moreover, the iron atoms in both compounds are in very similar environments and the values of the parameters measured were as expected if the  $\pi$ -electron

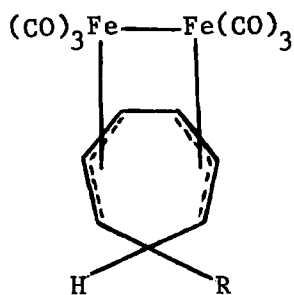
density in a planar  $C_4$  fragment of the rings is involved in the bonding of the rings to each iron atom, although the possibility that this interpretation may be revised in the light of more precise work has been mentioned.<sup>7</sup>

Collins and Pettit<sup>32</sup> have studied a range of neutral diene-iron carbonyl complexes and dienyl-iron tricarbonyl complex cations. In all cases a quadrupole doublet was observed; for the neutral complexes, the range of the Mossbauer parameters is  $\delta = -0.2 \pm 0.025 \text{ mm. sec}^{-1}$  and  $\Delta = 1.7 \pm 0.3 \text{ mm. sec}^{-1}$  relative to Cu, and for the ions the values were  $-0.1 \pm 0.02$  and  $1.7 \pm 0.2$  respectively. They were surprised to find that the two kinds of complexes had very similar isomer shifts, but were able to explain this in terms of  $\pi$ -back donation. The forward co-ordination process from the carbonium-ion ligands will be weaker than from the neutral dienes. The increase in s-electron density at the iron atom, associated with  $\sigma$ -donation, will therefore be less for the cationic complexes, so these should show a more positive shift. However, because of the positive charge on the cations, the greater back-donation should produce a negative shift by decreasing the d-shielding on the 4s-electrons. Thus, there are two opposing effects which apparently almost nullify each other. The slight dominance of forward co-ordination over back-donation is reflected in the slightly more negative values of  $\delta$  for the neutral complexes.

The same authors have also reported<sup>33</sup> results for a series of complexes of the type  $(\text{triene})\text{Fe}_2(\text{CO})_6$  in which they always observed only two narrow peaks, indicating that the two iron atoms are equivalent. This contrasts with King's<sup>34</sup> ferrole structure below which possesses two distinct kinds of iron atom.



On this basis, together with N.M.R. and dipole-moment measurements, they proposed the following bis- $\pi$ -allyl-iron carbonyl structure:



#### 4. Organotin-iron compounds

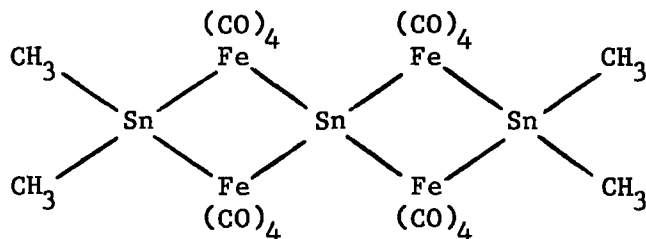
A good example of the use of Mossbauer spectroscopy in the elucidation of molecular structure is provided by a group of compounds containing tin and iron, and which are therefore susceptible to investigation using both the  $\text{Fe}^{57}$  and  $\text{Sn}^{119}$  Mossbauer lines. The relevant parameters are illustrated below:

Compound		+		Ref.
		Isomer Shift (mm. sec <sup>-1</sup> )	Quadrupole Splitting (mm. sec <sup>-1</sup> )	
$[\pi\text{-C}_5\text{H}_5\text{Fe}(\text{CO})_2]_2$	Fe(77 <sup>o</sup> k)	0.46	1.89	37
SnCl <sub>2</sub>	Sn "	3.6	0.9	"
$[\pi\text{-C}_5\text{H}_5\text{Fe}(\text{CO})_2]_2\text{SnCl}_2$	Fe "	0.361	1.64	"
	Sn "	1.94	2.37	"
$[\pi\text{-C}_5\text{H}_5\text{Fe}(\text{CO})_2]\text{SnCl}_3$	Fe "	0.488	1.94	"
	Sn "	1.90	1.90	"
$[\pi\text{-C}_5\text{H}_5\text{Fe}(\text{CO})_2]_2\text{Sn}(\text{CH}_3)_2$	Fe "	0.380	1.72	"
	Sn "	1.68	0	"
$[\pi\text{-C}_5\text{H}_5\text{Fe}(\text{CO})_2]_2\text{Sn}(\text{C}_2\text{H}_5)_2$	Fe "	0.373	1.88	"
	Sn "	1.74	0	"
$[\pi\text{-C}_5\text{H}_5\text{Fe}(\text{CO})_2]\text{Sn}(\text{C}_6\text{H}_5)_3$	Fe "	0.389	1.88	"
	Sn "	1.43	0	"
$[(\text{n-C}_4\text{H}_9)_2\text{SnFe}(\text{CO})_4]_2$	Fe "	0.238	0	38
	Sn "	1.70	1.26	"
$(\text{CH}_3)_2\text{SnFe}(\text{CO})_4]_2$	Fe(298 <sup>o</sup> k)	0.15	0.15	39
	Sn(78 <sup>o</sup> k)	1.47	1.22	"
$(\text{CH}_3)_4\text{Sn}_3\text{Fe}_4(\text{CO})_{16}$	Fe(298 <sup>o</sup> k)	0.16	0.30	"
	Sn(78 <sup>o</sup> k)	2.20	0	"
	Sn(" k)	1.45	1.24	"

+ Sn data relative to SnO<sub>2</sub> at 298<sup>o</sup>k

Fe data relative to Nitroprusside.

For those compounds based on  $[\pi\text{-C}_5\text{H}_5\text{Fe}(\text{CO})_2]_2$ , the isomer shifts of the tin resonance lines show that the metal has inserted itself into the Fe-Fe link of the dimer; this is consistent with the absence of bridging carbonyl bands in the infrared spectra of the complexes.<sup>40</sup> It is also interesting to note that Greenwood's rule for tin compounds<sup>41</sup> is obeyed, in that there is an absence of quadrupole splitting in the tin spectra for those compounds in which none of the nearest neighbours have unshared electron pairs which can bond to tin. The iron atoms for the alkyltin- $\text{Fe}(\text{CO})_4$  complexes show a very small quadrupole splitting. (A curve-resolver was necessary for the compounds given in ref.39, suggesting that this instrument might also resolve the single peak observed for  $[(n\text{-C}_4\text{H}_9)_2\text{SnFe}(\text{CO})_4]_2$  into the expected quadrupole doublet). In fact, very small quadrupole splittings have been observed for all  $\text{Fe}(\text{CO})_4$  moieties so far studied, provided the iron atom is approximately six-co-ordinate, and Herber<sup>7</sup> suggests this may be a characteristic feature of such fragments. Finally, Jones<sup>39</sup> showed that the structure of the complex  $(\text{CH}_3)_4\text{Sn}_3\text{Fe}_4(\text{CO})_{16}$  is as follows.



## 5. Conclusions

Now that the amount of information becoming available is quite large, the usefulness of this technique in studying iron carbonyl compounds is becoming apparent. Ideally, one would like to be able to use Mossbauer both as a means of "identification by fingerprints" and to give more detailed information about bonding characteristics, in much the same way that other branches of spectroscopy are used. In order to do this, one would have to correlate the sizes and changes in Mossbauer parameters with known structural and bonding factors in a very large number of compounds, and possibly with other kinds of spectroscopic data.

Herber, King and Wertheim<sup>26</sup> have attempted to do this for some fifty one organo-iron complexes in terms of a quantity  $\delta$  (The partial isomer shift of a ligand) and the  $\pi$ -bonding characteristics of the ligands around the iron atom. The compounds were considered in three groups;

(i) Those without  $\pi$ -bonding ligands

(ii) Those with five  $\pi$ -bonding electrons (mainly the cyclopentadienyl ligand)

(iii) Other  $\pi$ -bonding ligands.

Upon investigation of the data on compounds without  $\pi$ -bonding ligands, the relative constancy of the isomer shift for related molecules became apparent, so partial isomer shift values for individual

ligands were tabulated in such a way that the addition of the appropriate  $\int_i$  values leads to the observed value of  $\delta$  for the compound. This gave reasonably good internal consistency, in that a number of the ligands involved in several complexes having significantly different values of  $\delta$ , gave good agreement between experimentally determined isomer shifts and values calculated from partial isomer shifts.

For  $\pi$ -cyclopentadienyl compounds, however, it was not possible to obtain a single value for  $\int_{C_5H_5}$  since whatever model compound was chosen as a basis for the partial isomer shift value for the group, inconsistencies were found in the values for the other ligands bound to the iron atom. Instead, the authors found a good correlation between the N.M.R. shifts for  $\pi$ -C<sub>5</sub>H<sub>5</sub> protons (the chemical shifts of which are sensitive to the nature of the bonding between the ring and the iron atom) and values of  $\int_{C_5H_5}$  for several reference compounds. Then, for any other compound, the value of  $\int_{C_5H_5}$  was obtained from the N.M.R. chemical shift and the correlation diagram. This method gives good internal consistency for molecular compounds containing the  $\pi$ -cyclopentadienyl group and other ligands.

Unfortunately, reliable  $\int_i$  values could not be assigned to the third group of ligands, nor could any correlation with N.M.R. chemical shifts be found. The results for neutral complexes could not be extended to carbonyl cations, whatever ligands they contained, and the

N.M.R. chemical shift/Mossbauer isomer shift correlation failed for cationic  $\pi$ -C<sub>5</sub>H<sub>5</sub>Fe-compounds.

In conclusion, Herber et al. decided that any speculation regarding the significance of the results, and their relationship to bonding characteristics would be premature. This is understandable since no basic pattern was found; indeed the large number of inconsistencies found must make the simple concept of an additive parameter, such as partial isomer shift values rather questionable, however attractive it may be. These authors did not comment on the magnitudes of the  $\int_i$  values for each ligand, and the concept remains a purely empirical one.

One possibility that Herber, King and Wertheim did not consider was that the stereochemical environment of the iron atom might be significant, in that different hybridisation is invoked to give a picture of the bonding in, say, five and six co-ordination. These hybrid orbitals will have somewhat different s-orbital contributions, and will also provide different shielding of s-electrons from the nucleus because of their different d-orbital components. Thus, one might expect the partial isomer shifts for the ligands to be susceptible to the stereochemical arrangement of the ligands around the metal atom, and so it is surprising that values such as  $\int_{CO}$  (the partial isomer shift for the carbonyl group calculated as  $\frac{1}{5} \times \delta_{Fe(CO)_5}$ ) gave good results when used to calculate isomer shifts



in six co-ordinate carbonyl complexes.

One very important point which comes out of this survey of isomer shift values is that in some cases, two non-equivalent iron atoms may give rise to what appears to be a single resonance line. This condition occurs if the sum of the ligand partial isomer shifts for the two atoms happens to be equal, and is another fact which underlines the words of caution that have been voiced in connection with structural interpretation of Mossbauer data.

Thus, one must conclude that although a great deal of qualitative information concerning isomer shifts in iron-organic and iron carbonyl compounds has been accumulated, the relationships which have been found remain empirical, and that until a satisfactory, theoretically based method becomes available, a detailed interpretation of the exact values of isomer shifts in these complexes is not possible. The limitation applies whenever the Mossbauer effect is used to give structural information, although in simpler cases, the bonding factors involved are more clearly understood and a more complete rationalisation is possible.

Much the same kind of problems are encountered when trying to assess quantitatively the factors affecting the values of quadrupole splitting, because  $\Delta$  is so intimately tied up with the electronic structure of the atom itself. Fortunately, a good quantitative understanding of the variations of quadrupole splitting with molecular

structure has been built up, as described earlier, and this quantity will often yield more useful information to the chemist than measurements of isomer shift.

CHAPTER EIGHT

Experimental Techniques of Mossbauer Spectroscopy.

The equipment required when studying the Mossbauer effect, consisting essentially of radioactive source, an absorber, and a gamma-ray detector, has been described in detail in the literature.<sup>8-11</sup> The purpose of this chapter is to outline the instrumentation used during the course of this work, and to give further details of those aspects which are unique to the system. The need to modulate the energy of the source gamma-rays in order to allow an energy search is the fundamental feature of Mossbauer spectroscopy, and great emphasis is placed on source and sample preparation, since the chemical and physical properties of the environment of the nucleus are essential features of the experiments.

## 1. Sources

The sources used in this work, which were supplied enclosed in a perspex cylinder by the Radiochemical Centre, Amersham, were (a) 5 mC. Co<sup>57</sup> diffused into stainless steel, and (b) 10 mC. Co<sup>57</sup> diffused into a palladium matrix. The perspex cylinders were attached directly to the drive-spindle of the velocity modulator. Both sources give single unsplit lines, but since the palladium source gave a narrower line, better resolution was obtained, particularly when quadrupole splittings were small.

## 2. Absorbers

There is an optimum thickness for the absorber since the width of the resonance peak is affected by the thickness.<sup>9</sup> It is necessary to

have the absorber sufficiently thick to give a reasonable resonance effect, but too thick an absorber causes line broadening. Samples were studied either in the solid state, or as a frozen solution, and since all the samples were highly air-sensitive, all sample handling operations were performed in a nitrogen atmosphere. Solid samples were milled with silicone vacuum grease and the resulting paste (containing, preferably, about 50 mg./cm.<sup>2</sup>) pressed between the windows (thin aluminium foil) of a cell made from a copper ring. For samples in solution, special solution cells were constructed in copper and stainless steel along similar lines to the solution cells used for infrared spectra, except that the windows were thin aluminium foil, and the path length was about 1/4". The solution was introduced into the cell by syringe, the inlet and outlet tubes were stoppered using screws, and the whole cell was then immersed in liquid nitrogen.

The cold sample-cell was then bolted to the cryostat and maintained at about 80°K. Although the cells were exposed to the air while spectra were being recorded, it was found that decomposition under these conditions was negligible over a period of several days.

### 3. Cryostat and Sample Holder

The sample mounting device and cryostat are represented diagrammatically in Fig.8-1. The cryostat consisted essentially of an insulated copper rod, the lower end of which was immersed in liquid

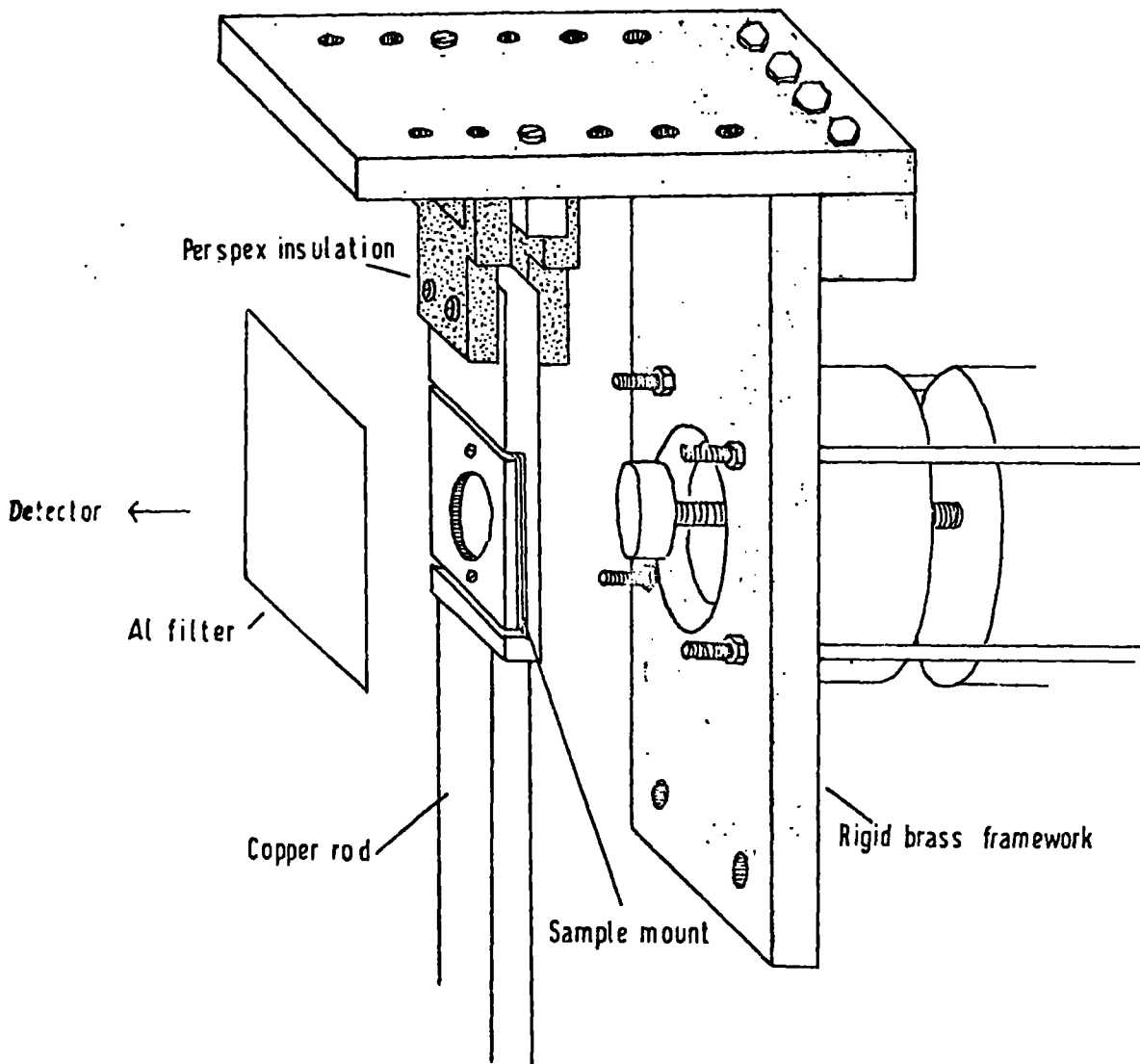


Fig. 8-1 Diagramatic representation of cryostat. For clarity the expanded polystyrene insulation is not shown.

nitrogen. The level of the liquid nitrogen was maintained automatically.<sup>9</sup> The copper rod was thermally insulated from the rigid brass framework by perspex, and the sample mount was secured in place over the circular hole in the rod as shown in Fig.8-1. The supporting framework was made from half-inch brass plate, bolted rigidly together in order that vibrations of the sample relative to the source were kept to a minimum. A copper-constantan thermocouple was incorporated into the copper sample mount so that variations of Mossbauer parameters with temperature changes could be observed.

#### 4. Velocity Modulator

By far the most convenient energy modulation technique is based on the Doppler effect, and was used by Mossbauer in his original experiments, although the mechanisms now used bear little resemblance to those originally used. The system used in the experiments to be described used a velocity sweep method, triggered by a multi-channel analyser (M.C.A.). The source sweeps periodically through a range of velocities, and the counts in predetermined ranges of velocities are stored in different channels of the multi-channel analyser. A block diagram of the system, in which the M.C.A. is being used in its time mode is shown in Fig.8-2.

Inside the M.C.A. is a precise frequency oscillator which causes the M.C.A. to step through its 512 channels sequentially. It spends 62.5 sec. (typically) in each channel and accepts all the counts which

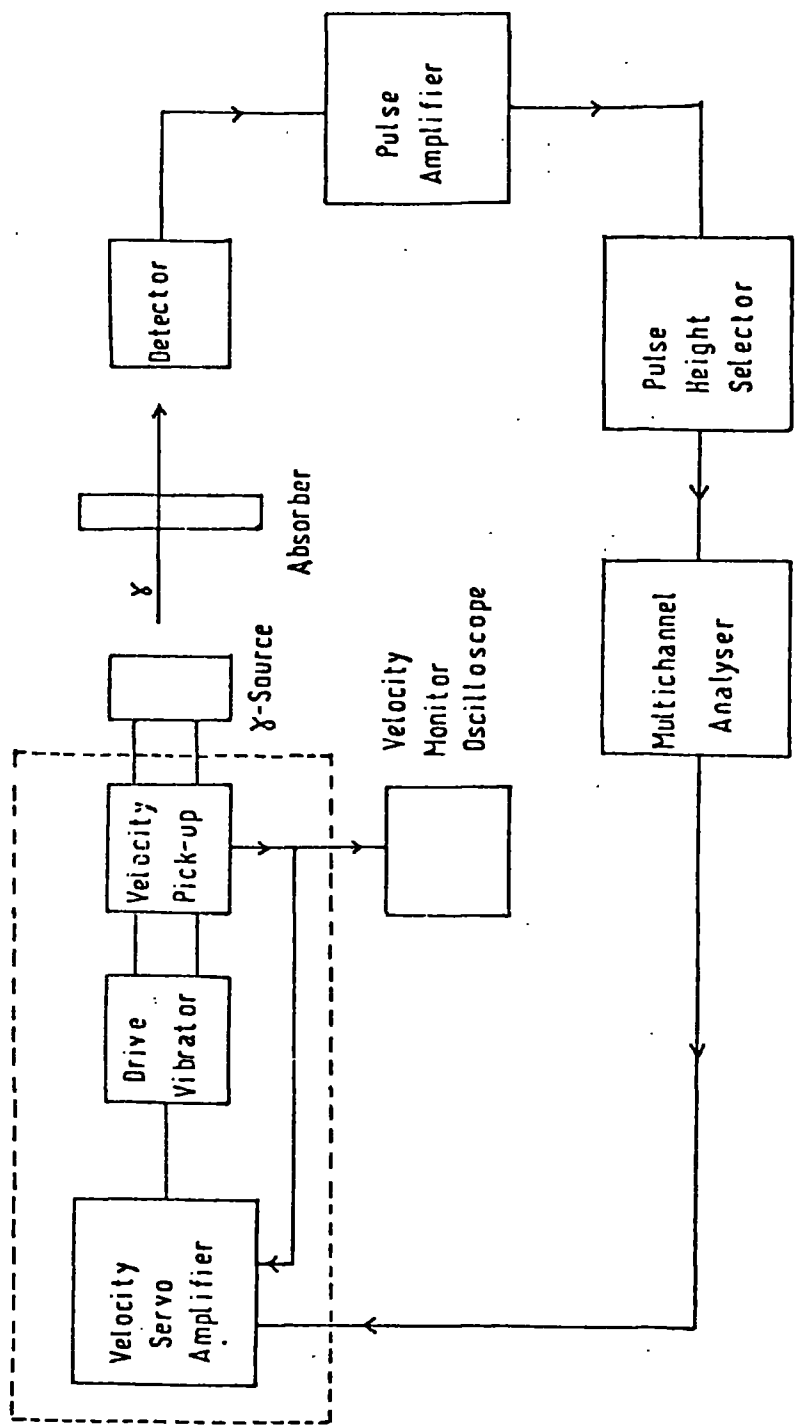


Fig 8-2 Block diagram of the Time Mode system.



come in. As the channels are switched, the velocity of the source is automatically changed, and since equal time is spent in each channel, a perfectly flat baseline is obtained.

#### 5. Gamma-Ray Detector

A scintillation counter, employing a sodium iodide crystal was used. It had an aluminium window which apparently contained a trace of iron, because over a very large number of counts ( $\sim 2$  million) a resonance effect, taking the form of an asymmetric doublet, was observed. However, this effect was very small, and during an actual experiment could be considered to be negligible.

#### 6. The Co<sup>57</sup> Energy Spectrum

Using the apparatus described above, it was found that both the useful 14.4 KeV gamma-ray and the soft X-ray (7 KeV) produced by internal conversion were recorded (see Fig. 6-1). The latter rays were eliminated from the spectra by setting the pulse-height-selector to accept only the 14.4 KeV gamma-ray.<sup>9</sup>

#### 7. Calibration of the Velocity Scale

The velocity scale was calibrated using the known<sup>35</sup> value ( $1.712 \pm 0.002$  mm/sec.) for the quadrupole splitting of sodium nitroprusside, and all the isomer shift values given in the experimental section are referred to the centroid of the nitroprusside peaks. Wherever possible, calibration runs were performed before and after recording a spectrum in order to evaluate instrumental drift during the experiment.

## 8. Treatment of Data

The data stored and accumulated in the multi-channel analyser was automatically punched onto computer-tape. The programmes used were developed by Dr. T.C. Gibb,<sup>36</sup> and gave estimates of the peak positions, half-widths and intensities, together with the standard deviations of each of these parameters. More recently a programme that will subtract one set of peaks from a given spectrum has been written by R. Greatrex. However, the usefulness of this type of approach for spectra believed to be derived from mixtures of more than one species is questionable in certain circumstances, especially where peaks overlap. This has received a mathematical treatment by Gibb et al.<sup>16</sup> who have shown that overlapping peaks are not independent, so their intensities are not strictly additive. However, this effect is considered to be small except when two equally intense peaks overlap to a large extent, so the curve analysis methods adopted during the course of this work give results which are correct to a first approximation in intensity.

CHAPTER NINE

Structural Studies of Carbonyl and Hydrido-carbonyl Species of Iron

## 1. Introduction

The structures of metal carbonyl hydrides have attracted much interest and it is only recently that the nature of the bonding in these compounds has been clarified. Carbonyl hydrides are known for most transition elements as both neutral and negatively charged species of widely differing nuclear complexity, and new ones are prepared with regularity, especially now that the method of mass spectroscopy has become available for their characterisation. In aqueous solution, many of the carbonyl hydrides behave as strong acids, so their salts are also available for study; generally structural information is more readily obtained for the latter.

The isolation and handling of most of the unsubstituted hydrido metal carbonyls is usually difficult because of their volatility and instability to air and heat (several are thermally unstable at room temperature). For this reason, some are of doubtful existence or have never been isolated in a pure state. Structural studies are, therefore, particularly difficult.

In this work, a systematic study of the Mossbauer and infrared spectral properties of the hydrides and anions tabulated (Table 9-1) has been attempted. The iron system was chosen because four series of related hydrides and their salts, based on different arrangements of iron atoms are known.

Table 9-1

Nuclear Complexity	Parent Carbonyl	Carbonyl Anion	Hydridocarbonyl Anion	Carbonyl Hydride
1	$\text{Fe}(\text{CO})_5$	$[\text{Fe}(\text{CO})_4]^{2-}$	$[\text{Fe}(\text{CO})_4\text{H}]^-$	$\text{Fe}(\text{CO})_4\text{H}_2$
2	$\text{Fe}_2(\text{CO})_9$	$[\text{Fe}_2(\text{CO})_8]^{2-}$	$[\text{Fe}_2(\text{CO})_8\text{H}]^-$	$\text{Fe}_2(\text{CO})_8\text{H}_2$ <sup>a</sup>
3	$\text{Fe}_3(\text{CO})_{12}$	$[\text{Fe}_3(\text{CO})_{11}]^{2-}$	$[\text{Fe}_3(\text{CO})_{11}\text{H}]^-$	$\text{Fe}_3(\text{CO})_{11}\text{H}_2$ <sup>b</sup>
4	$\text{Fe}_4(\text{CO})_{14}$ <sup>a</sup>	$[\text{Fe}_4(\text{CO})_{13}]^{2-}$	$[\text{Fe}_4(\text{CO})_{13}\text{H}]^-$	$\text{Fe}_4(\text{CO})_{13}\text{H}_2$

a Unknown, or of postulated existence only.

b Not isolated in a pure state.

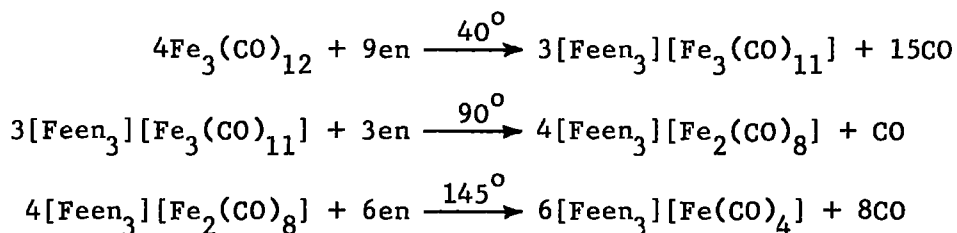
Mossbauer spectroscopy, used to provide information about the local environment of each iron atom, is particularly useful when studying a series of this type because there are several ways of checking for internal consistency. The most important of these is that detailed structural information (usually crystallographic) of at least one member of each series is available, so structural conclusions can be checked and the reliability of the results confirmed.

The eight anionic carbonyl derivatives listed in Table 9-1 have all been obtained by treatment of the three parent carbonyls with hydroxides, although the product of any given reaction is critically dependent on the conditions. All the solutions obtained in these reactions are highly sensitive to oxidation and changes in the pH, and there is some confusion in the literature concerning the exact



Acidification of all these solutions leads either to formation of the corresponding hydridocarbonyl anion or to polymerisation to  $[\text{Fe}_3(\text{CO})_{11}\text{H}]^-$  which seems to be one of the most stable of all these species. If more strongly acid conditions are used,<sup>47-8</sup> the carbonyl hydrides are formed, all of which are easily oxidised to  $\text{Fe}_3(\text{CO})_{12}$ , and a sequence of reactions of this type is believed to cause formation of  $\text{Fe}_3(\text{CO})_{12}$  in its preparation from  $\text{Fe}(\text{CO})_5$ .<sup>48</sup>

Reaction of various iron carbonyls with nitrogen-bases proceeds by an even larger variety of reaction paths to the different iron carbonyl anions, depending on the base, the carbonyl and the reaction conditions. However, these reactions have been more closely studied than those above, and the nature of the products more fully substantiated. The equations below illustrate the dependence on conditions of the reaction between  $\text{Fe}_3(\text{CO})_{12}$  and ethylenediamine,<sup>48</sup>



and, as a contrast, reaction of  $\text{Fe}(\text{CO})_5$  or  $\text{Fe}_3(\text{CO})_{12}$  with pyridine yields only  $[\text{Fepy}_6][\text{Fe}_4(\text{CO})_{13}]$ .<sup>57</sup>

All the polynuclear dianions react with CO under pressure to give the mononuclear derivative  $[\text{Fe}(\text{CO})_4]^{2-}$ .<sup>58</sup>

## 2. Preparation of the Compounds used for Spectroscopic Study

The preparative procedures to be described are all based on literature methods, but because mixtures of products were often obtained, especially in the early part of this study, modifications were introduced in several cases. Because the peaks in the Mossbauer spectra of Fe(II) and Fe(III) complex cations overlap the peaks arising from the carbonyl anions being studied, the different procedures were usually designed to yield the anions as salts of organic cations (tetraethylammonium typically). While these experimental modifications were being developed, some new degradations and polymerisations were discovered, which, under favourable conditions, caused quantitative conversion. These are summarised in Fig.9-2, and will be described in detail where appropriate.

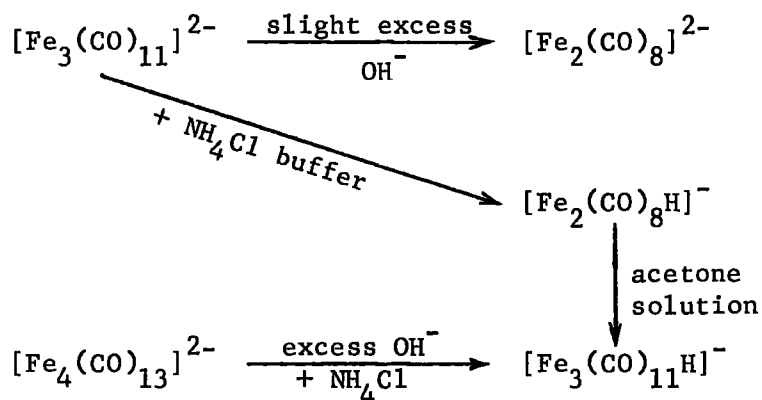
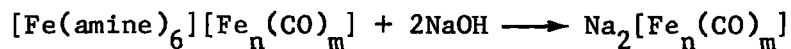


Fig.9-2



The  $\text{NH}_4\text{Cl}$  in these reactions almost certainly buffers the solution to the pH values relevant for formation of the hydrido-carbonyl ferrates. Excess hydroxide ion refers to an excess of the base over the molar quantities required for a conversion of the type



Satisfactory iron analyses were obtained for the compounds prepared by the methods to be described, but since several samples of each compound were prepared in order to check the reproducibility of the results, analytical data for each individual compound will not be quoted. Iron analyses were performed by the method described in Appendix 3. Conventional combustion methods of analysis for C and H were found to be unsuitable for these compounds - the samples were so oxygen-sensitive that explosions often occurred in the combustion-tube.

All the reactions and operations to be described were performed in an atmosphere of oxygen-free  $\text{N}_2$  using deoxygenated reactants and solvents.

#### Preparation of $\text{Na}_2\text{Fe}(\text{CO})_4$ <sup>49</sup>

A mixture of  $\text{NaOH}$  (6 g.),  $\text{Ba}(\text{OH})_2$  (5.1 g.) and  $\text{Fe}(\text{CO})_5$  (5 ml.) was stirred in water (75 ml.) at room temperature for 20 hrs. The solution was then filtered and pumped to dryness to give a pale-pink solid residue which was used directly for spectral measurements (it contained some excess hydroxide).  $\text{Na}_2\text{Fe}(\text{CO})_4$  is very light sensitive,

decomposing over a few days to a brown solid, so the product was protected from light at all times.

When a solution of  $\text{Et}_4\text{NI}$  was added to an aqueous solution of the sodium salt in an attempt to precipitate  $[\text{Et}_4\text{N}]_2[\text{Fe}(\text{CO})_4]$ , a biscuit-coloured precipitate of pure  $[\text{Et}_4\text{N}][\text{Fe}(\text{CO})_4\text{H}]$  was obtained, because the conditions were not sufficiently alkaline. The second dissociation constant of  $\text{Fe}(\text{CO})_4\text{H}_2$  is very much lower than the first.

King<sup>50</sup> described the preparation of a solution of  $\text{Na}_2\text{Fe}(\text{CO})_4$  in THF by heating a sodium dispersion with  $\text{Fe}_3(\text{CO})_{12}$  in this solvent. However, addition of  $\text{Et}_4\text{NI}$  in ethanol to such a solution yielded only  $[\text{Et}_4\text{N}]_2[\text{Fe}_2(\text{CO})_8]$ .

#### Preparation of $[\text{Et}_4\text{N}][\text{Fe}(\text{CO})_4\text{H}]$

$\text{Fe}(\text{CO})_5$  (7 ml.) was stirred with concentrated aqueous ammonia (200 ml.) for 24 hrs.<sup>51</sup> The red-brown solution was filtered, and a solution of  $\text{Et}_4\text{NI}$  (3 g. in 20 ml. water) added dropwise. The pale-pink precipitate of  $[\text{Et}_4\text{N}][\text{Fe}(\text{CO})_4\text{H}]$  was filtered, washed well with water and dried in vacuo.

#### Preparation of $\text{Fe}(\text{CO})_4\text{H}_2$

This material was prepared on a vacuum line as described in Part I (p.56). The spectra were recorded in hexane solution.

#### Preparation of $[\text{Et}_4\text{N}]_2[\text{Fe}_2(\text{CO})_8]$

$\text{Fe}_2(\text{CO})_9$  (1 g.) was stirred with methanolic KOH (25 ml. N solution) until a deep red solution of the sodium salt was obtained.<sup>52</sup> This was

filtered, and an equimolar quantity of  $\text{Et}_4\text{NI}$  in aqueous KOH solution (N solution) was added dropwise. The resulting deep red precipitate was filtered, washed with water (3 x 20 ml.) and pumped dry.

Alternative Preparation of  $[\text{Fe}_2(\text{CO})_8]^{2-}$  from  $[\text{Fe}_3(\text{CO})_{11}]^{2-}$

$[\text{Feen}_3][\text{Fe}_3(\text{CO})_{11}]$  (0.7 g.) was stirred with 20 ml. 0.1N aqueous KOH for one hour, and the deep red solution filtered. Dropwise addition of  $\text{Et}_4\text{NI}$  (1 gm.) solution in water precipitated  $[\text{Et}_4\text{N}]_2[\text{Fe}_2(\text{CO})_8]$  which was washed and pumped dry.

Preparation of  $[\text{Et}_4\text{N}][\text{Fe}_2(\text{CO})_8\text{H}]^{45}$

$\text{Fe}_2(\text{CO})_9$  (4 g.) was stirred with 100 ml. Normal methanolic KOH for  $2\frac{1}{2}$  hrs. The red solution was filtered and cooled to  $-50^\circ$  in an acetone bath before the slow addition of an acetic acid solution (made up from 9 ml. glacial acetic acid, 75 ml. water and 75 ml. methanol).  $\text{Et}_4\text{NI}$  solution (3 g. in 20 ml. water) was slowly added dropwise to the resulting deep red solution. The mustard yellow precipitate of the product was filtered from the deep red solution, whose smell and general properties indicated the presence of hydride.

$[\text{Et}_4\text{N}][\text{Fe}_2(\text{CO})_8\text{H}]$  is one of the most air-sensitive of all these compounds; samples often glowed red-hot in the air.

Conversion of  $[\text{Fe}_3(\text{CO})_{11}]^{2-}$  into  $[\text{Fe}_2(\text{CO})_8\text{H}]^-$

$[\text{Feen}_3][\text{Fe}_3(\text{CO})_{11}]$  (2.4 g.) was stirred with 90 ml. 0.2N aqueous KOH solution for an hour. The solution was filtered and  $\text{NH}_4\text{Cl}$  (6 g.) in 40 ml. water added, followed by  $\text{Et}_4\text{NI}$  (2.1 g.) in 20 ml. water.

The precipitated  $[\text{Et}_4\text{N}][\text{Fe}_2(\text{CO})_8\text{H}]$  was filtered, washed well with water and pumped dry.

When a sample of this mustard-yellow salt was dissolved in acetone (in order to measure its spectral parameters in solution), a deep red solution was obtained. The Mossbauer spectrum of this solution (Frozen at  $-196^\circ$ ) showed the characteristic peaks of  $[\text{Fe}_3(\text{CO})_{11}\text{H}]^-$  and the infrared spectrum was consistent, in the terminal carbonyl stretching region, with the presence of this species, although the spectrum also showed that some of the dinuclear anion was present. The two species have quite different spectra in the bridging-carbonyl region, but the very strong absorption of the solvent obscured this part of the spectrum.

#### Attempted Preparation of $\text{Fe}_2(\text{CO})_8\text{H}_2$

According to the literature, this compound has not previously been isolated, but is a postulated intermediate in the acidification of  $[\text{Fe}_2(\text{CO})_8]^{2-}$  to  $[\text{Fe}_3(\text{CO})_{11}\text{H}]^{-45}$ .

Addition of  $\text{H}_3\text{PO}_4$  to both  $[\text{Et}_4\text{N}][\text{Fe}_2(\text{CO})_8\text{H}]$  and  $\text{K}_2\text{Fe}_2(\text{CO})_8$  in a vacuum system gave a small yield of  $\text{Fe}(\text{CO})_5$  as the only product volatile at room temperature. Heating the reaction mixture to  $50^\circ$  under vacuum gave a very small yield of a deep red solid which was collected in a trap at  $-196^\circ$ , but the quantity produced was insufficient for study.  $\text{Fe}_3(\text{CO})_{12}$  remained in the reaction flask. Further possible routes to this compound are being investigated.

Preparation of  $[\text{Feen}_3][\text{Fe}_3(\text{CO})_{11}]$ <sup>54</sup>

$\text{Fe}_3(\text{CO})_{12}$  (7.5 g.) and ethylenediamine (10 ml.) were stirred at 0° for 10 minutes. Water (5 ml.) was then added and the syrupy mixture filtered. The very dark red filtrate was stirred on a water-bath maintained at 40-45° while water (100 ml.) was added slowly over 15 mins. This caused separation of the product as a brown-orange crystalline solid, which was washed several times with water and pumped dry.

This material is slowly air-sensitive when dry, but immediately decomposes in air when wet. It is slightly soluble in water, and moderately soluble in polar organic solvents. All attempts to prepare the tetraethylammonium salt resulted in degradation to dinuclear species or formation of  $[\text{Fe}_3(\text{CO})_{11}\text{H}]^-$  as already described, thus illustrating the extreme importance of reaction conditions in these systems.

Preparation of  $[\text{Et}_4\text{N}][\text{Fe}_3(\text{CO})_{11}\text{H}]$ <sup>55</sup>

$\text{Fe}_3(\text{CO})_{12}$  (3.8 g.) was stirred with aqueous KOH (30 ml., 2N) until no  $\text{Fe}_3(\text{CO})_{12}$  remained. The deep red solution was filtered and glacial acetic acid (70 ml.) added. On the addition of  $\text{Et}_4\text{NI}$  (2.6 g. in 60 ml. water), a fine dark red precipitate of the product was obtained, which was filtered, washed with water, and pumped dry.

Attempted Preparation of  $\text{Fe}_3(\text{CO})_{11}\text{H}_2$

(i) Acidification of  $[\text{Et}_4\text{N}][\text{Fe}_3(\text{CO})_{11}\text{H}]$  with orthophosphoric acid

yielded large quantities of  $\text{Fe}_3(\text{CO})_{12}$ , and a little volatile (at  $50^\circ$ ) red material, but this latter product was obtained in such small quantities that this possible route was abandoned.

(ii) Passage of HCl through an ether solution of  $[\text{Feen}_3][\text{Fe}_3(\text{CO})_{11}]$  gave no reaction at  $-36^\circ$ , but at slightly higher temperatures ( $-10$  to  $-20^\circ$ ) the solution darkened. Only  $\text{Fe}_3(\text{CO})_{12}$  could be detected in the reaction mixture.

(iii) Acidification of an aqueous solution of  $\text{Na}_2\text{Fe}_3(\text{CO})_{11}$  produced a mixture of  $\text{Fe}(\text{CO})_5$ ,  $\text{Fe}_3(\text{CO})_{12}$ ,  $[\text{Fe}_3(\text{CO})_{11}\text{H}]^-$  and probably some hydride, but this could not be separated from the other products.

Preparation of  $[\text{Fepy}_6][\text{Fe}_4(\text{CO})_{13}]^{53}$

Pyridine (15 ml.) was added slowly to  $\text{Fe}_3(\text{CO})_{12}$  (10 g.), and after the initial vigorous frothing had subsided, the mixture was stirred until CO evolution had ceased (1 hr.). The fine powdery product, which is very soluble in excess pyridine, was filtered, washed well with hexane and pumped dry.

When freshly prepared, this compound is pyrophoric in air and smells strongly of pyridine. It is somewhat soluble in acetone.

Preparation of  $[\text{Et}_4\text{N}]_2[\text{Fe}_4(\text{CO})_{13}]$

$[\text{Fepy}_6][\text{Fe}_4(\text{CO})_{13}]$  (3.6 g.) and 50 ml. 0.1N aqueous NaOH solution were stirred together for 3 hrs. The deep red solution was filtered, buffered with  $\text{NH}_4\text{Cl}$  (2 g.) and an aqueous solution of  $\text{Et}_4\text{NI}$  (1.5 g. in 35 ml.) added dropwise. The voluminous dark red precipitate was

filtered, washed with water (5 x 20 ml.) and pumped dry. This salt is rather more air-stable than the  $[\text{Fepy}_6]^{2+}$  salt, decomposing in the air over about 3 hrs. In the preparation of this salt, it is essential that even a very slight excess of hydroxide is not used, since conversion of the tetranuclear ion to trinuclear species occurs easily.

Preparation of  $[\text{pyH}][\text{Fe}_4(\text{CO})_{13}\text{H}]^{53}$

$[\text{Fepy}_6][\text{Fe}_4(\text{CO})_{13}]$  (3.4 g.) was stirred with 30 ml. aqueous KOH solution (30 ml., 0.2N) until a deep red solution was obtained. This was filtered and acidified with hydrochloric acid (35-40 ml., 0.2N) when a thick, syrupy sediment was formed. The clear solution was syringed from the reaction flask and about 100 ml. weakly acid water ( $\text{N}/100$ ) added. This mixture was then shaken vigorously until the syrup coagulated into a fine, deep red precipitate, which was filtered, washed with water and pumped dry. The product was pyrophoric, and very soluble in acetone, methanol and ether. Again, it is essential during this preparation that excess alkali is not present. On several occasions, mixtures containing the  $[\text{Fe}_3(\text{CO})_{11}\text{H}]^-$  ion in varying amounts were present - the addition of only about a 10% excess of hydroxide leads to quantitative production of the trinuclear hydrido anion.

Attempted Preparation of  $\text{H}_2\text{Fe}_4(\text{CO})_{13}$

Attempts to prepare this hydride were made by the method of Hieber

and Werner.<sup>57</sup> The solution obtained by stirring 6 g.  $[\text{Fepy}_6][\text{Fe}_4(\text{CO})_{13}]$  with 100 ml. aqueous 0.2N KOH was filtered into a separating funnel equipped with side arms for the introduction of  $\text{N}_2$ , and acidified with 25 ml. hydrochloric acid (1:1 aqueous solution). The deep red precipitate was then extracted into ether, the ethereal solution was washed three times with normal hydrochloric acid solution and dried over  $\text{MgSO}_4$  for an hour before filtering. Removal of the ether left a red-black residue, which has been reported to be the hydride.<sup>57</sup> However, Mossbauer spectroscopy showed that it always contained some  $[\text{Fe}_4(\text{CO})_{13}\text{H}]^-$ , and a pure sample was never obtained.



### 3. Results and Discussion

The Mossbauer parameters are given a confidence limit of  $\pm 0.01$  mm. sec<sup>-1</sup>, but in all cases reproducibility of the values were observed well within these limits over a long period of time. For this reason, some values will be quoted to a third decimal place when it is believed that this gives a better representation of the value. In all cases, the spectra were recorded at 80°K.

#### a) Mononuclear Species

The Mossbauer spectra for Fe(CO)<sub>4</sub>H<sub>2</sub>, [Fe(CO)<sub>4</sub>H]<sup>-</sup> and [Fe(CO)<sub>4</sub>]<sup>2-</sup> are shown in Fig.9-4. The infrared and Mossbauer data for the ionic mononuclear species are shown in Table 9-2, together with values from the literature for comparison. The spectra of Fe(CO)<sub>4</sub>H<sub>2</sub> will be discussed separately.

Table 9-2

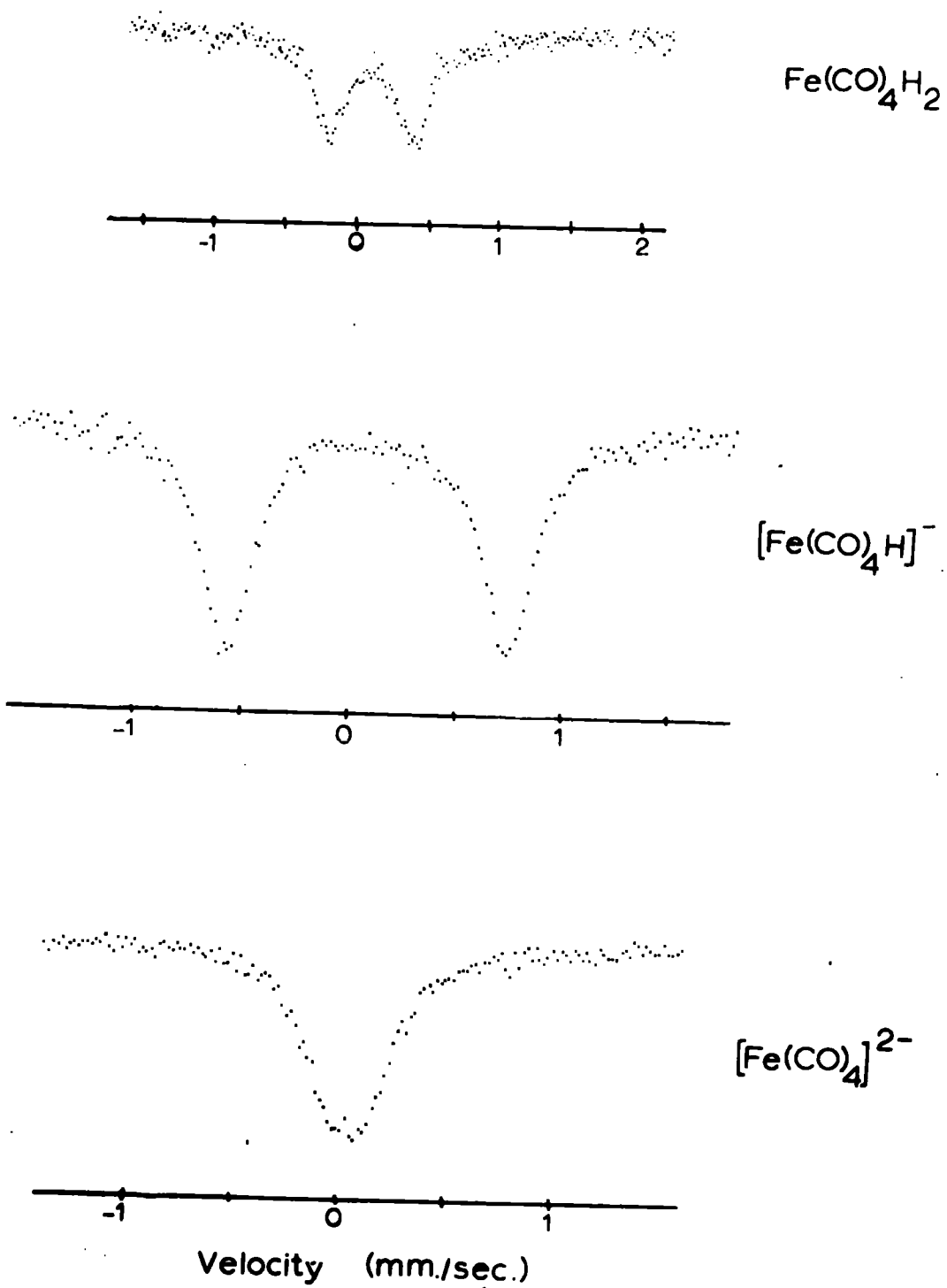
		Na <sub>2</sub> Fe(CO) <sub>4</sub>	[Et <sub>4</sub> N][Fe(CO) <sub>4</sub> H]
Infrared (cm <sup>-1</sup> )	ν(C-O)	1761*	2008(w-m), 1910(m, sh), 1848(s, br)
	Nujol		
	Litt. Values	1730 <sup>a</sup> 1786 <sup>b</sup>	2015(w), 1937(sh), 1897(vs) <sup>b</sup>
Mossbauer (mm. sec <sup>-1</sup> )	δ	0.08 <sub>0</sub>	0.09 <sub>5</sub>
	Δ	~0	1.36 <sub>8</sub>

a in DMF<sup>59</sup>

b in water<sup>62</sup>

\* broad with several shoulders

FIG. 9-4. Mössbauer Spectra of Mononuclear Species.



(i)  $[\text{Fe}(\text{CO})_4]^{2-}$ : The infrared<sup>59,62</sup> and Raman<sup>60</sup> spectra of  $[\text{Fe}(\text{CO})_4]^{2-}$  have been reported, and both are consistent with the expected tetrahedral arrangement of CO groups. The single C-O stretching frequency observed in this work is thereby confirmed. The Mossbauer spectrum is also consistent with this structure, there being only one peak, as required for an iron atom in a cubic environment. However, the line-width of the peak ( $0.44 \text{ mm. sec}^{-1}$ ) is somewhat larger than is usually observed for a single sharp Mossbauer line (which is typically<sup>61</sup>  $0.3-0.35 \text{ mm. sec}^{-1}$  for the instruments used in this work), suggesting a very small unresolved quadrupole splitting. Fitting two peaks constrained to have equal intensity and half width gave a maximum splitting of  $0.18 \text{ mm. sec}^{-1}$ . This splitting is very small indeed and is probably insignificant, since it must be a consequence of a minor factor, such as crystal packing.

The isomer shift value is the lowest that has been reported for a carbonyl complex. Only complexes of  $\text{Fe}^{6+}$ , or containing NO as in the nitroprusside ion are found below this.<sup>8,82</sup> The tendency to lower  $\delta$  values as the oxidation states reach extreme values is, in each case, due to the reduction in shielding of s-electrons from the nucleus as d-electron density is removed from the atom. In one case it is loss of d-electron density by ionisation, and in the case of  $[\text{Fe}(\text{CO})_4]^{2-}$  the excess negative charge on the metal is dissipated by d-electron delocalisation on to the CO groups, as is also reflected

in the very low C-O stretching frequency.

The different values obtained for  $\nu(\text{C-O})$  in this and other work show how greatly the position of the bands are affected by solvents of high dielectric constant. For other iron carbonylate salts also, absorbtions are shifted by up to  $50 \text{ cm}^{-1}$  on dissolution in D.M.F.<sup>59</sup>

(ii)  $[\text{Fe}(\text{CO})_4\text{H}]^-$ : The view that hydrogen probably occupies a definite position in the co-ordination sphere of the metal in hydrido carbonyl compounds is verified by the results obtained for this ion. A tetrahedral arrangement of the CO groups is excluded totally by the Mossbauer spectrum, since the large quadrupole splitting value can only be interpreted in terms of a large electric field gradient at the iron atom resulting from the co-ordination state, since the iron atom conforms to the inert gas rule.

Possible structures are as follows:

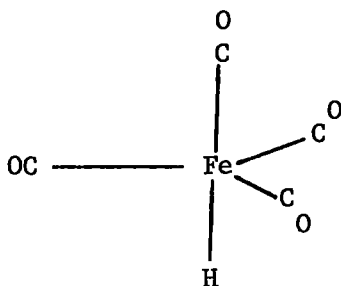
A. Trigonal bipyramidal with three CO groups and the iron atom in the equatorial plane, with the hydrogen atom occupying a full co-ordination position.

B. A distorted version of A in which the three equatorial CO groups are nearer to the H atom, giving a distorted tetrahedral arrangement of the four CO groups

Both structures A and B are of  $C_{3v}$  symmetry and are consistent with the Raman spectrum,<sup>60</sup> which is unable to distinguish between the two possibilities. The Mossbauer spectrum, however, favours

the distorted structure B because the observed quadrupole splitting ( $1.36 \text{ g. mm. sec}^{-1}$ ) is less than values observed for complexes in which the iron atom is known to be in a trigonal bipyramidal environment. Thus values about  $2.5 \text{ mm. sec}^{-1}$  have been reported for  $\text{Fe}(\text{CO})_5$  and its substitution products with phosphines and arsines.<sup>25,28</sup>

The infrared spectrum also favours B as follows. For structure I, three infrared active



I

C-O stretching modes are expected ( $2A_1 + E$ ). One of the  $A_1$  modes corresponds to the symmetrical "breathing" mode of the three equatorial CO groups, and when these are in the same plane as the iron atom, very little change in the dipole moment of the complex would be generated, so a very weak infrared band would be expected. However, as the three CO groups are moved towards the hydrogen atom, the dipole moment change associated with this mode will increase, with a consequent increase in the intensity of this peak in the

spectrum. The bands in the spectra of several  $\text{Co}(\text{CO})_4\text{L}$  species ( $\text{L} = \text{H}^{66}$ ,  $\text{PR}_3^{66}$ , Halogen<sup>70</sup>) have been assigned - the highest frequency band to  $A_1$  (equatorial), the next highest frequency band to  $A_1$  (axial) and the most intense broader band at low frequency to the E mode, and similar band intensities to those for  $[\text{Fe}(\text{CO})_4\text{H}]^-$  are observed. However, arguments based on the intensity of what, on first considerations, should be a weak band are not very rigorous because its intensity can be increased by Fermi resonance with other modes of the same symmetry species (particularly if they are strongly allowed bands), and so this infrared evidence is only taken as indicative of distortion when considered alongside the Mossbauer data.

The results, therefore show that  $[\text{Fe}(\text{CO})_4\text{H}]^-$  and  $\text{Co}(\text{CO})_4\text{H}$  have similar structures, as well as being isoelectronic. All X-ray diffraction studies of transition metal hydrides show that the hydrogen atom occupies an independent co-ordination site, but neighbouring ligands incline towards them from their idealised position because of their repelling power and the small size of the hydride ligand,<sup>63-65</sup> and although no X-ray work on  $\text{Co}(\text{CO})_4\text{H}$  has been published, a detailed infrared study by Bor<sup>66</sup> has shown that the declination angle  $\alpha$  (see Fig.9-3) is as great as  $11.5 \pm 1.5^\circ$

If the declination angle  $\alpha$  is taken to be an approximate measure of the distortion from pure trigonal bipyramidal symmetry

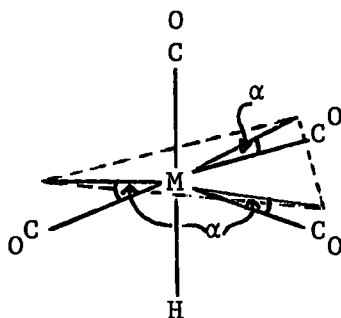


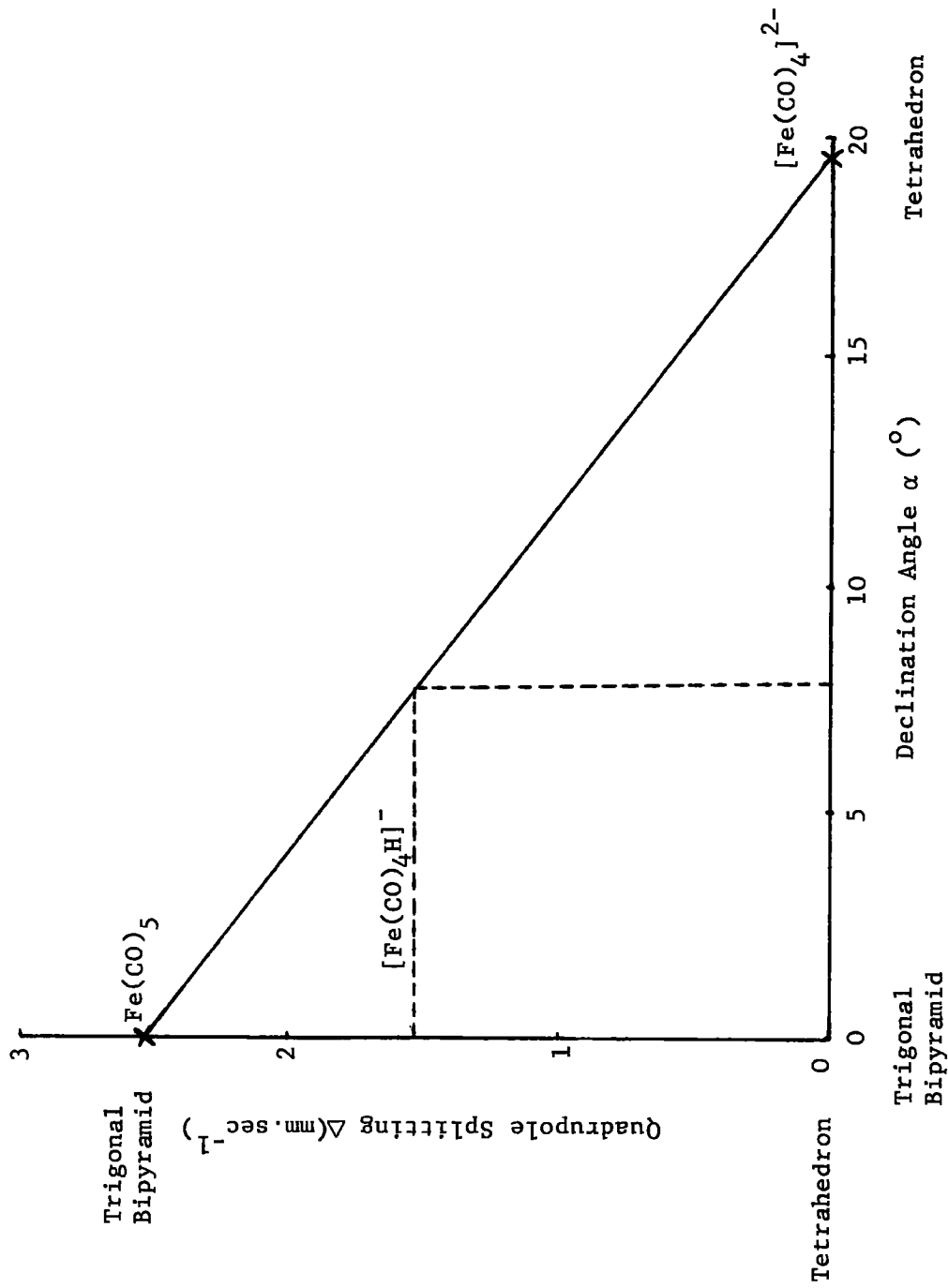
Fig.9-3 The declination angle  $\alpha$  in  $M(CO)_4H$  species

(which in the limit of tetrahedral symmetry would be  $109.5^\circ - 90^\circ = 19.5^\circ$ ), then there could be a correlation between this distortion and the Mossbauer quadrupole splitting which is also a direct measure of this distortion. Using a correlation diagram (Fig.9-5) and the observed value of  $\Delta$  for  $[Fe(CO)_4H]^-$ , a predicted angle of declination of  $\sim 9^\circ$  is obtained which compares well, in view of the large approximations involved, with the value observed for  $Co(CO)_4H$  ( $11.5^\circ$ )<sup>66</sup>. The isostructural nature of  $[Fe(CO)_4H]^-$  and  $Co(CO)_4H$  is therefore considered to be well substantiated by these results.

(iii) Fe(CO)<sub>4</sub>H<sub>2</sub>: The high sensitivity of this compound to air and its ready decomposition above  $-10^\circ$  meant that special techniques were required to handle it. Solutions of the hydride were maintained at all times at  $-78^\circ$ , and were introduced by use of a pre-cooled syringe in to cells which were kept under an atmosphere of nitrogen in a large vessel immersed in a bath maintained at  $-78^\circ$ . The infrared spectra were also recorded at  $-78^\circ$  using a low temperature cell

Fig. 9-5

Correlation Diagram of Mossbauer Quadrupole Splitting ( $\Delta$ ) vs Declination Angle ( $\alpha$ )





developed in this department.

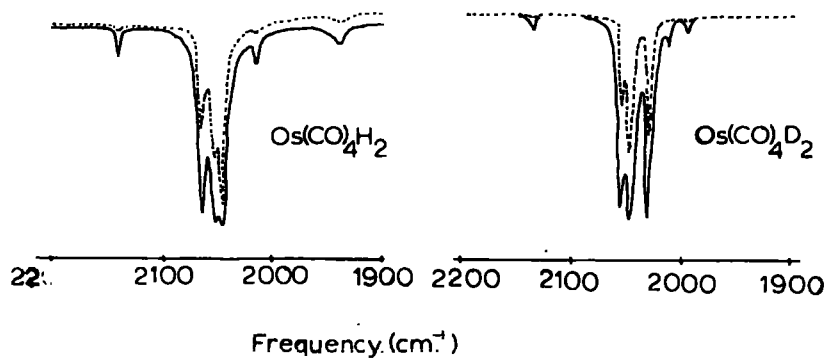
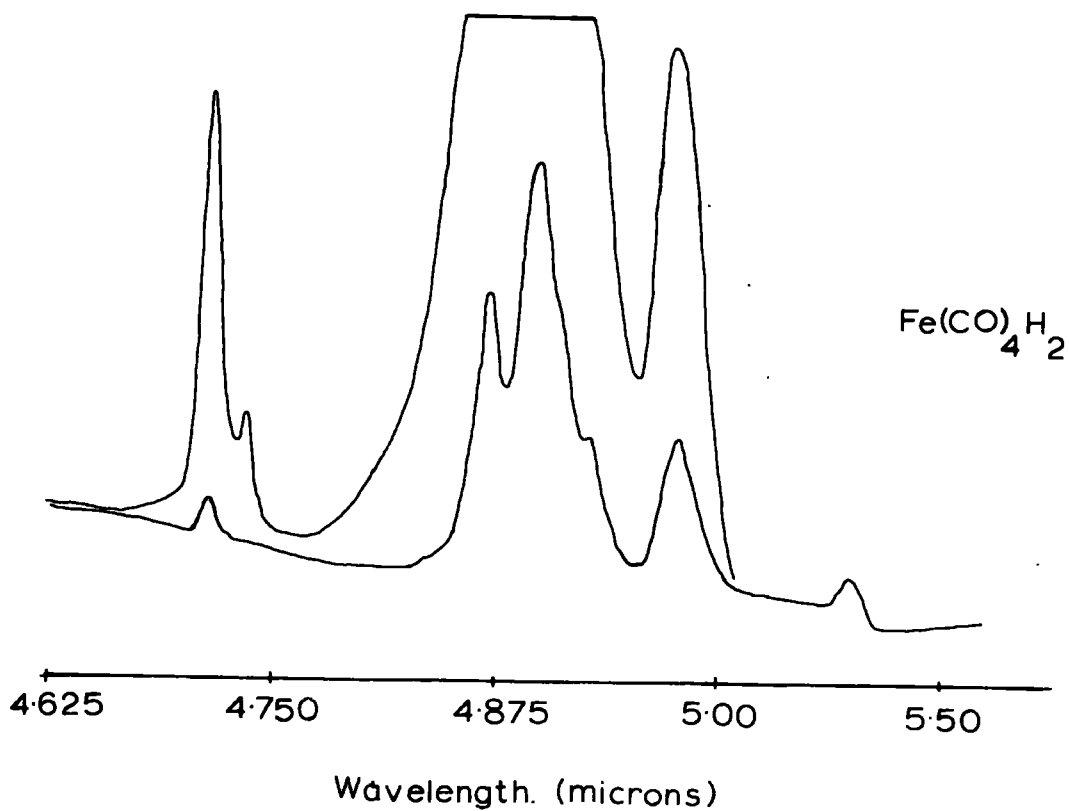
The infrared spectrum of  $\text{Fe}(\text{CO})_4\text{H}_2$  is shown in Fig.9-6, together with the spectrum of  $\text{Os}(\text{CO})_4\text{H}_2$  which is reproduced from the paper by L'Eplattenier and Calderazzo.<sup>76</sup> The infrared assignments and Mossbauer parameters are presented in Table 9-3

Table 9-3

Assignment	Infrared bands ( $\text{cm}^{-1}$ )	Isomer Shift $\delta$ ( $\text{mm. sec}^{-1}$ )	Quadrupole Splitting $\Delta$ ( $\text{mm. sec}^{-1}$ )
$\nu(\text{C-O})$	2121(w)	0.08 <sub>5</sub>	0.61 <sub>5</sub>
$\nu(^{13}\text{C-O})$	2111(vw)		
$\nu(\text{C-O})$	2053(m)		
$\nu(\text{C-O})$	2042(s)		
$\nu(^{13}\text{C-O})$	2029(w)		
$\nu(\text{C-O})$	2010(m)		
$\nu(\text{Fe-H})$	1887(m)		

The isomer shift value (0.08<sub>5</sub>  $\text{mm. sec}^{-1}$ ) is much the same as the values for the other mononuclear species, and will be discussed at the end of the chapter. The small quadrupole splitting value falls in the range expected for octahedral iron complexes<sup>28</sup> and is consistent with a cis-arrangement of the hydride ligands, although the data available for comparison is limited; this value is also consistent with

FIG. 9-6. Infrared Spectra of  $\text{Fe}(\text{CO})_4\text{H}_2$ ,  $\text{Os}(\text{CO})_4\text{H}_2^{76}$ ,  
&  $\text{Os}(\text{CO})_4\text{D}_2^{76}$ .



a distorted tetrahedral arrangement of the CO groups around the iron atom.

The infrared data, on the other hand, is strongly suggestive of the formulation  $\text{cis-Fe(CO)}_4\text{H}_2$ , which would be analogous to the corresponding  $\text{cis-Os(CO)}_4\text{H}_2$ , and their spectra are indeed very similar, as illustrated in Fig.9-6. A carbonyl derivative of thus type, having  $C_{2v}$  symmetry, should give rise to four C-O stretching vibrations ( $2A_1 + B_1 + B_2$ ) as shown in Fig.9-7, and four main bands are

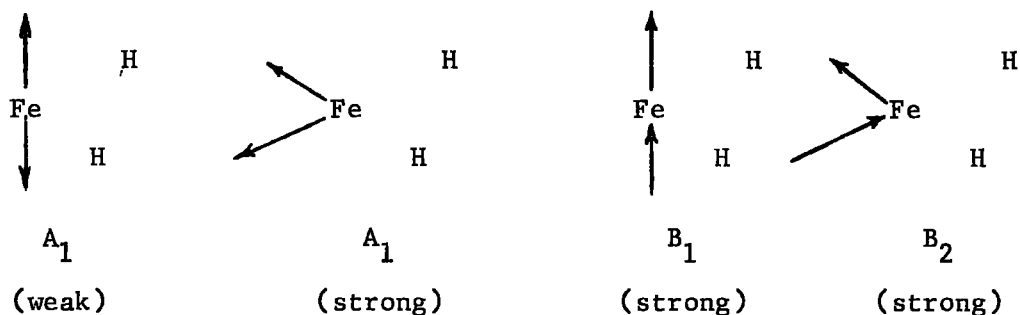


Fig.9-7 C-O Stretching Modes for  $\text{cis-Fe(CO)}_4\text{H}_2$

observed, including the weak mode of  $A_1$  symmetry to high frequency. The very weak bands at  $2111 \text{ cm}^{-1}$  (only seen for a very strong solution) and  $2029 \text{ cm}^{-1}$  are assigned to  $^{13}\text{C-O}$  stretching vibrations.

Although deuteration of  $\text{Fe(CO)}_4\text{H}_2$  was not attempted, the rather broad band at about  $1887 \text{ cm}^{-1}$  is assigned to iron-hydrogen stretching as follows:

(i) All reported  $\nu(\text{M-H})$  for metal carbonyl hydrides occur below  $2000 \text{ cm}^{-1}$ .<sup>77</sup>

(ii) In general, for molecules differing only in the metal atom,  $\nu(\text{M-H})$  increases on going down a periodic group<sup>78</sup> (this only applies for transition elements), and so  $\nu(\text{Fe-H})$  would be expected at lower frequency than  $\nu(\text{Os-H})$  which has been observed<sup>76</sup> at  $1940 \text{ cm}^{-1}$  and confirmed by deuteration.

(iii) The shape of the band at  $1887 \text{ cm}^{-1}$  and its position relative to the C-O bands are very similar to those observed for  $\text{Os}(\text{CO})_4\text{H}_2$  (Fig.9-6).

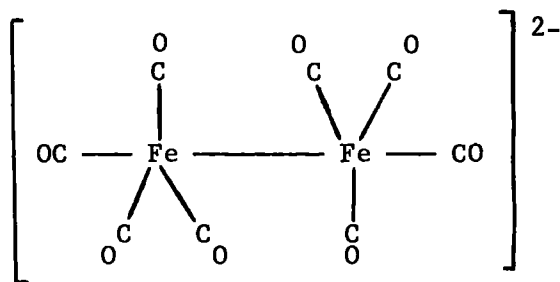
The presence of only one metal-hydrogen stretching band when two ( $A_1 + B_1$ ) would be expected probably means that it contains both vibrations, as is consistent with the broad nature of the band. The other possibility, that the second vibration coincides with one of the C-O stretching vibrations cannot be discounted without comparison with the spectrum of the deuterio-complex, although no coincidence of this kind was found<sup>76</sup> for  $\text{Os}(\text{CO})_4\text{H}_2$ , and the broad band in this spectrum is therefore assumed to contain both vibrations.

As additional evidence that  $\text{H}_2\text{Fe}(\text{CO})_4$  has a cis-octahedral structure, the p.m.r. spectral data of the solid hydride has recently been reinterpreted<sup>83</sup> to show that the H-Fe-H angle is  $80 \pm 8^\circ$ .

b) The Dinuclear Anions

(i)  $[\text{Fe}_2(\text{CO})_8]^{2-}$

This ion is believed to have the  $D_{3d}$  structure II<sup>67</sup>



## II

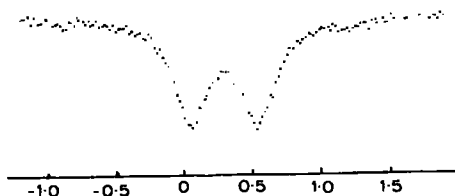
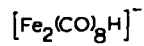
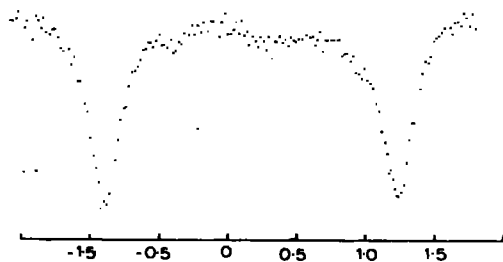
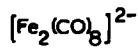
based on a trigonal bipyramidal arrangement of groups about each iron atom. The Mossbauer spectrum (Fig.9-8) shows that both iron atoms are in identical environments, and the quadrupole splitting value ( $2.21 \text{ mm. sec}^{-1}$ ) is consistent with five co-ordination, although it is slightly lower than for most purely trigonal bipyramidal iron carbonyl complexes. This may suggest that the equatorial CO groups are not quite coplanar with the iron atoms, or that the electron-pair forming the Fe-Fe bond is in a more diffuse orbital than the other bond pairs.

The infrared spectrum of this ion under low resolution consists of two broad bands, each consisting of several shoulders. They are centred at  $1920(\text{m})$  and  $1852(\text{s}) \text{ cm}^{-1}$  (Nujol mull) and are not resolved in solution (in D.M.F., the band positions<sup>59</sup> are at  $1916(\text{m})$  and  $1866(\text{s}) \text{ cm}^{-1}$ ). Under high resolution, the bands were so close together that they were also not resolved and so structural conclusions based on these spectra are not possible. However, the

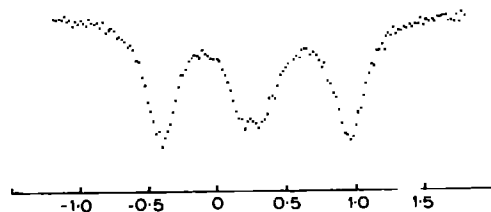
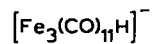
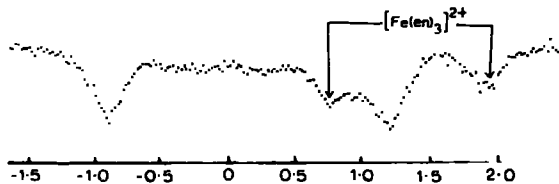
**FIG. 9-8**

**Mössbauer Spectra of Di-, Tri- and Tetranuclear Iron Carbonyl Anions.**

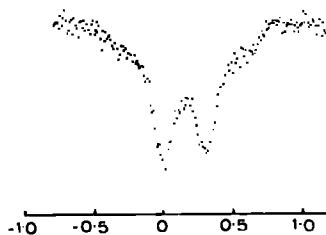
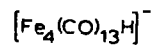
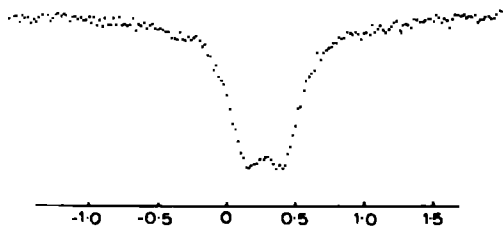
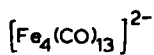
**DINUCLEAR SPECIES**



**TRINUCLEAR SPECIES**

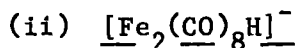


**TETRANUCLEAR SPECIES**



← Velocity (mm / sec) →

shape of the spectrum in the CO region was the same for several different samples and is characteristic of this ion. There were no bands in the bridging carbonyl region.



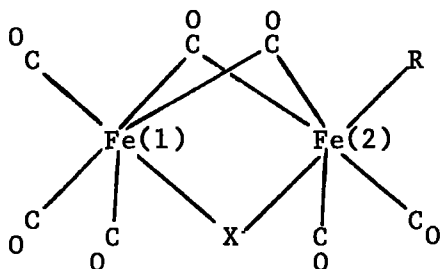
The data obtained for  $[\text{Et}_4\text{N}][\text{Fe}_2(\text{CO})_8\text{H}]$  are presented in Table 9-4, together with the relevant data for  $\text{Fe}_2(\text{CO})_9$ , which is included for comparison. The Mossbauer spectrum is shown in Fig.9-8.

Table 9-4

Species	Infrared* $\nu(\text{C-O})$ ( $\text{cm}^{-1}$ )	Isomer Shift $\delta(\text{mm. sec}^{-1})$	Line width at Half-height ( $\text{mm. sec}^{-1}$ )	Quadrupole Splitting $\Delta(\text{mm. sec}^{-1})$									
$[\text{Fe}_2(\text{CO})_8\text{H}]^-$	<table style="display: inline-table; border: none;"> <tr> <td>2068(w)</td> <td rowspan="5">} terminal</td> </tr> <tr> <td>2045(w)</td> </tr> <tr> <td>1997(s)</td> </tr> <tr> <td>1923(vs)</td> </tr> <tr> <td>1860(s)</td> </tr> <tr> <td>1778(m)</td> <td rowspan="2">} bridging</td> </tr> <tr> <td>1750(s)</td> </tr> </table>	2068(w)	} terminal	2045(w)	1997(s)	1923(vs)	1860(s)	1778(m)	} bridging	1750(s)	0.32 <sub>5</sub>	0.33	0.50 <sub>4</sub>
2068(w)	} terminal												
2045(w)													
1997(s)													
1923(vs)													
1860(s)													
1778(m)	} bridging												
1750(s)													
$\text{Fe}_2(\text{CO})_9$	<table style="display: inline-table; border: none;"> <tr> <td>2082(s)</td> <td rowspan="2">} terminal</td> </tr> <tr> <td>2026(s)</td> </tr> <tr> <td>1845(s)</td> <td rowspan="3">} bridging</td> </tr> <tr> <td>1833(s)</td> </tr> <tr> <td>1825(sh)</td> </tr> </table>	2082(s)	} terminal	2026(s)	1845(s)	} bridging	1833(s)	1825(sh)	0.42 <sub>0</sub>	0.32	0.42 <sub>5</sub>		
2082(s)	} terminal												
2026(s)													
1845(s)	} bridging												
1833(s)													
1825(sh)													

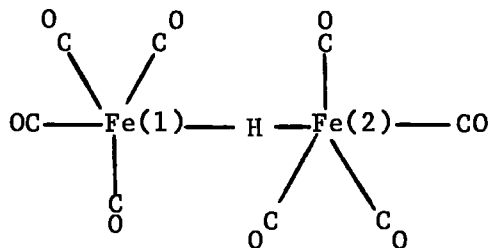
\* Nujol Mull

The three most likely structures in which the hydrogen is bound directly to iron are those derived from  $\text{Fe}_2(\text{CO})_9$  (I and II) or from  $[\text{Fe}_2(\text{CO})_8]^{2-}$  (III) as shown in Fig.9-9



I (X = H, R = CO)

and II (X = CO, R = H)



III

Fig.9-9 Possible Structures of the ion  $[\text{Fe}_2(\text{CO})_8\text{H}]^-$

Structure III, which is analogous to  $[\text{M}_2(\text{CO})_{10}\text{H}]^-$  (where M = Cr, Mo or W),<sup>71,72</sup> can be discounted, because (i) the infrared spectrum of the anion shows bands in the bridging carbonyl region, and (ii) the low value of the quadrupole splitting is inconsistent with a five co-ordinate iron atom.<sup>28</sup>

In structure II, the iron atom (1) would be in a very similar environment to that of the iron atoms in  $\text{Fe}_2(\text{CO})_9$ , and different from that of Fe(2); thus the Mossbauer spectrum should consist of four peaks,



two of which would be similar to those observed for  $\text{Fe}_2(\text{CO})_9$ . The observed spectrum, however, consists of only two unbroadened peaks in positions different from those observed for  $\text{Fe}_2(\text{CO})_9$ . The two iron atoms are therefore equally affected by the presence of the hydrogen atom, which must be in a bridging position, as in structure I.

The fact that the Mossbauer spectrum is very similar to that of  $\text{Fe}_2(\text{CO})_9$  indicates the similarity of their structures. The infrared spectrum of the anion is consistent with structure I, which has  $C_{2v}$  symmetry, for which five terminal modes,  $2A_1 + 2B_1 + B_2$ , and two bridging modes,  $A_1 + B_2$  are predicted. The terminal modes are represented in Fig.9-10, and the bridging modes in Fig.9-11.

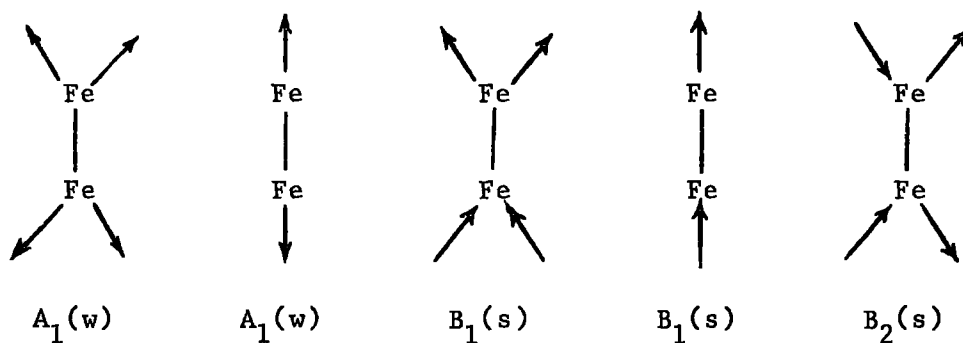


Fig.9-10 Terminal C-O Stretching Modes



Fig.9-11 Bridging C-O Stretching Modes

In the solid state, therefore, the  $[\text{Fe}_2(\text{CO})_8\text{H}]^-$  ion is isoelectronic and isostructural with  $\text{Co}_2(\text{CO})_8$  (i.e. with  $\text{Co}_2(\text{CO})_8$  in the solid state,<sup>73</sup> or in its 'low-temperature solution form'<sup>74,75</sup>). However, cobalt carbonyl has been shown<sup>74,75</sup> to exist in two isomeric forms in solution, the second having no bridging carbonyl groups. In acetone, the yellow-brown salt  $[\text{Et}_4\text{N}][\text{Fe}_2(\text{CO})_8\text{H}]$  gave a deep red solution, and new bands appeared, but the Mossbauer spectrum of such a solution indicated that it contained mainly the trinuclear ion  $[\text{Fe}_3(\text{CO})_{11}\text{H}]^-$ , so it was not possible to ascertain whether a similar isomerisation in solution does occur in the iron system.

c) The Trinuclear Anions

(i)  $[\text{Fe}_3(\text{CO})_{11}]^{2-}$

As described earlier, the tetraethylammonium salt of this anion could not be prepared in a pure state, and so the spectra of  $[\text{Feen}_3][\text{Fe}_3(\text{CO})_{11}]$  were recorded. The Mossbauer spectrum, therefore, contains two peaks to high velocity (Fig.9-8) arising from the cation, and since they are in the positions typical of high spin iron(II) complexes, they will not be discussed further. The data is shown in Table 9-5.

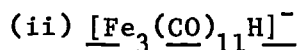
The Mossbauer spectrum verifies that all the iron atoms are in equivalent environments, since there is only one quadrupolar-split pair of unbroadened lines. This is consistent with the preliminary reports of the X-ray structure,<sup>80</sup> which is shown in Fig.9-12.



atoms in  $[\text{Fe}_2(\text{CO})_8]^{2-}$  (where  $\Delta = 2.21 \text{ mm. sec}^{-1}$ ), and this may be an indication that the triply-bridging carbonyl groups contribute very little to the quadrupole splitting. Each iron atom in the remaining  $\text{Fe}_3(\text{CO})_9$  nucleus would then be formally five co-ordinate, with three CO groups and two  $\text{Fe}(\text{CO})_3$  fragments as nearest neighbours.

The infrared spectrum is very complicated in the terminal carbonyl region - the band positions quoted in Table 9-5 are the maxima on a broad, complex band. Of notable interest, however, are two well resolved weak bands at high frequencies. If both bands arise from an isolated molecular unit, then a highly symmetrical  $D_{3h}$  structure, with a plane of symmetry passing through the iron atoms, is unlikely because only one A mode is predicted. However, the complexity of the spectrum in this region may be an indication that the vibrations involve many molecules in the lattice, when more than one A vibration could be allowed. In solution, good resolution was not achieved because of the broadening effect of the polar solvents involved, and only two diffuse bands, with maxima at about 1940 and 1910  $\text{cm}^{-1}$  are observed.

The band at 1592  $\text{cm}^{-1}$  is tentatively assigned to a vibration of the bridging carbonyl groups since it is at the very low frequency expected for triply-bridging CO groups in a doubly charged anion. However, ethylenediamine in the cation also has bands in this region, so this cannot be an unambiguous assignment.



The structure of this ion has been determined by an X-ray analysis (see Chapter 7, Fig.7-2), and the Mossbauer spectrum is entirely consistent with this. The spectrum at room temperature has been reported<sup>22</sup> and the values ( $\delta = 0.28$ ,  $\Delta = 0.2$  for inner pair;  $\delta = 0.26$ ,  $\Delta = 1.32$  mm.sec<sup>-1</sup> for outer pair) are in agreement with those obtained in this study. The apparent difference between these, and values obtained at 80<sup>o</sup>K (Table 9-6) is a result of a 'second order Doppler shift'.

Table 9-6

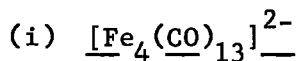
Infrared $\nu(\text{C-O})$ cm <sup>-1</sup>			Mossbauer (mm.sec <sup>-1</sup> )	
Nujol Mull	Methanol Solution	D.M.F. <sup>59</sup> Solution	Isomer Shift ( $\delta$ )	Quadrupole Splitting ( $\Delta$ )
2067(w)	2068(w)	2070(w)	0.29 <sub>5</sub> <span style="margin-left: 100px;">1.41</span>	outer pair
2001(s)	2009(vs)	2004(s)		
1981(s)	1980(s)	1980(m)	0.27 <sub>7</sub> <span style="margin-left: 100px;">0.16</span>	inner pair
1953(s)	1957(m)	1950(w)		
1932(s)				
1741(s)	1748(w)			

The two identical iron atoms, being in a highly distorted octahedral environment,<sup>23</sup> give rise to a pair of lines with a large quadrupole splitting (the outer pair); the third iron atom is in a cis-octahedral environment, which results in a small  $\Delta$  value (the inner pair). The

spectrum is therefore entirely consistent with the known structure of this ion when it is in the solid state. An identical Mossbauer spectrum was also observed in solution, strongly suggesting that the structure is the same, but the strong bridging C-O stretching band in the infrared spectrum of a Nujol mull of  $[\text{Et}_4\text{N}][\text{Fe}_3(\text{CO})_{11}\text{H}]$  becomes a weak one in methanol solution (see Table 9-6), and was not reported for a D.M.F. solution. This behaviour has also been observed for the closely related  $\text{Fe}_3(\text{CO})_{12}$ .<sup>23</sup>

The carbonyl bands in the terminal  $\nu(\text{C-O})$  region are poorly resolved, and so little structural information can be obtained from them, but again, the spectra are somewhat different in solid and solution states.

d) The Tetranuclear Species



The structure<sup>81</sup> of this ion, shown in Fig.9-15 below consists of

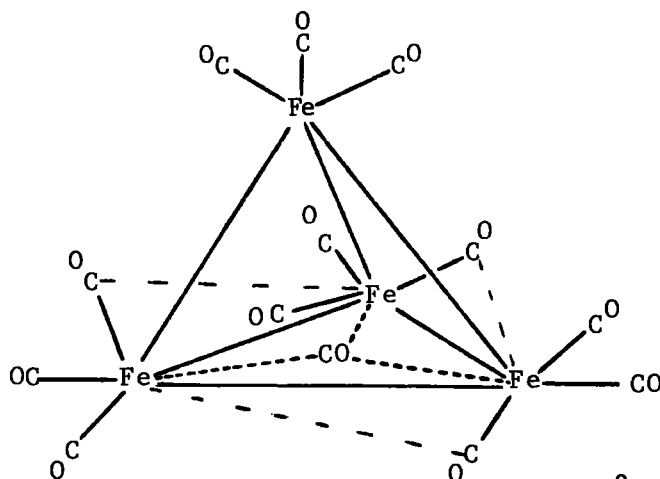


Fig.9-15 The structure of the  $[\text{Fe}_4(\text{CO})_{13}]^{2-}$  ion

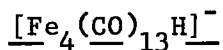
one unique iron atom symmetrically bound to the three iron atoms of an  $\text{Fe}_3(\text{CO})_{10}$  unit, and which is therefore in an octahedral environment. The three iron atoms forming the base of the tetrahedron are all equivalent, and are held together by Fe-Fe bonds and a triply-bridging CO group. There is also weak interaction between one of the 'terminal' CO groups on each iron atom and a neighbouring one, so there are thus three weakly bridging CO groups also.

The Mossbauer spectrum of  $[\text{Et}_4\text{N}]_2[\text{Fe}_4(\text{CO})_{13}]$  apparently consists of only two bands of normal line-width (Fig.9-8;  $\delta = 0.28_6$ ,  $\Delta = 0.27_1$  mm.sec<sup>-1</sup>) suggesting that the two different kinds of iron atoms give rise to very similar parameters, and therefore overlapping peaks. The small quadrupole splitting confirms that the unique iron atom is in an octahedral environment, and since the others must also be in an e.f.g. of approximately cubic symmetry, it suggests that the effect of the triply-bridging CO group is very small. Then, all four iron atoms are effectively surrounded by three mutually cis CO groups and three  $\text{Fe}(\text{CO})_3$  groups, and are therefore in a pseudo-octahedral environment.

In the infrared spectrum, using a solid sample, at least seven bands are resolved in the terminal C-O stretching region. Their positions are 2068(vw), 2025(w), 2003(w), 1953(sh), 1938(s), 1931(sh), 1919(s), 1876(s), 1867(sh). In acetone solution, although the Mossbauer spectrum remains unchanged, the infrared spectrum becomes much simpler because of the broadening effect of the polar solvent,<sup>69,79</sup>

and only three strong bands are resolved, at 2007(m), 1945(vs) and 1895(m).

The position of the band due to the triply-bridging carbonyl group has been the source of uncertainty in the literature. A band at 1644  $\text{cm}^{-1}$  in one of these salts was originally<sup>82</sup> thought to be due to a ketonic impurity, but Dahl<sup>81</sup> et al. have suggested that this may be the  $\nu(\text{C-O})$  band expected. They have also suggested that the band at 1600  $\text{cm}^{-1}$  in  $[\text{Fepy}_6][\text{Fe}_4(\text{CO})_{13}]$  may be the C-O band, but note that pyridine also absorbs in this region. The spectrum of  $[\text{Fepy}_6][\text{Fe}_4(\text{CO})_{13}]$  does indeed contain a band at 1600  $\text{cm}^{-1}$ , but there is also a weak band at 1661  $\text{cm}^{-1}$  not reported by Dahl et al. This latter band is also present in the tetraethylammonium salt, whereas the 1600  $\text{cm}^{-1}$  one is not. It is therefore concluded that the band at 1600  $\text{cm}^{-1}$  arises from the pyridine in the  $[\text{Fepy}_6]^{2+}$  cation, and that the vibration of the triply-bridging CO group occurs at 1661  $\text{cm}^{-1}$ .



Many samples ( 20) of  $[\text{PyH}][\text{Fe}_4(\text{CO})_{13}\text{H}]$  were prepared because the Mossbauer spectra, especially of earlier samples, were not reproducible. Two strong peaks were always observed, but two weaker peaks usually occurred which varied in intensity. These peaks are believed to arise from the presence of varying amounts of  $\text{H}_2\text{Fe}_4(\text{CO})_{13}$  impurity because they were absent from the spectra of carefully prepared samples, and samples which did show these peaks shortly after



preparation did not after the sample had been allowed to stand at room temperature for several days (the hydride is known<sup>53</sup> to decompose at room temperature). The main peaks were reproducible, however.

The Mossbauer spectrum consists (Fig.9-8) of two peaks, one of which is slightly broader than the other. The parameters ( $\delta = 0.31$ ,  $\Delta = 0.70 \text{ mm. sec}^{-1}$ ), especially the quadrupole splitting, are different from those observed for  $[\text{Fe}_4(\text{CO})_{13}]^{2-}$ , showing that all four iron atoms are affected by the presence of the hydrogen atom. The slight reproducible asymmetry of the spectrum suggests that they are not all identical, but it would be meaningless to resolve the spectrum into components by computer.

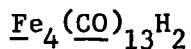
The infrared spectrum of this salt is not particularly helpful in the terminal C-O stretching region although the position of the centre of the broad band is very little changed from that found for the dianion. There is also a weak/medium, broad band at  $1680 \text{ cm}^{-1}$ , which is assigned to the stretching vibration of a triply-bridging CO group. This frequency is comparable to that of the band arising from the triply-bridging carbonyl group in the dianion, so it is concluded that the basal  $\text{Fe}_3(\text{CO})_{10}$  unit remains unchanged structurally by the presence of the hydrogen. However, the Mossbauer spectrum shows that the electric-field gradient at all the iron atoms changes with the presence of the hydrogen atom, and it is proposed that the hydrogen atom occupies a position within the tetrahedron of iron atoms, where it can then affect all four atoms.

Recently,<sup>84</sup> the infrared and mass spectra of the tetranuclear mixed complexes  $\text{HFeCo}_3(\text{CO})_{12}$  and  $\text{HRuCo}_3(\text{CO})_{12}$  have been interpreted as indicating an identical situation to that proposed in  $[\text{Fe}_4(\text{CO})_{13}\text{H}]^-$ . In these two complexes, it was suggested that the hydrogen is bound to Fe or Ru, but is located within the tetrahedron of iron atoms, where it would be in a position to interact with the basal triangle of Co atoms. Indeed, if the average M-M bond distance in the tetrahedron is taken as  $2.55\overset{\circ}{\text{A}}$  (Co-Co in  $\text{Co}_4(\text{CO})_{12}$  is  $2.5\overset{\circ}{\text{A}}$ ;<sup>23</sup> Fe-Fe in  $[\text{Fe}_4(\text{CO})_{13}]^{2-}$  is  $2.6\overset{\circ}{\text{A}}$ <sup>81</sup>) and the hydrogen is placed at the centroid, an average M-H distance of  $1.5\overset{\circ}{\text{A}}$  is obtained which is consistent with other known M-H distances.<sup>83</sup>

The data reported for these mixed cobalt derivatives could not give any direct indication that the hydrogen atom is affecting all the metal atoms, although this was suggested as a probability. Attempts to obtain a high field p.m.r. signal from the hydrogen atom in  $[\text{Fe}_4(\text{CO})_{13}\text{H}]^-$  (in acetone solution) were unsuccessful, as was also the case for the cobalt complexes,<sup>84</sup> probably indicating that these protons have a short relaxation time - a difficulty that has been encountered in other polynuclear carbonyl hydrides.<sup>85</sup>

Mossbauer spectroscopy, however, which is very sensitive to changes in the electronic environment of the iron atoms is much more definitive, and strongly indicates that the hydrogen atom is four-co-ordinate. This is therefore a good example of the use of this technique to obtain

directly chemically significant information which is difficult to obtain from any other source.



Several attempts were made to prepare this hydride, but in each case the Mossbauer spectrum was poorly resolved in the region where the strongest peaks occurred - the parameters of two of the maxima being characteristic of the  $[\text{Fe}_4(\text{CO})_{13}\text{H}]^-$  ion, suggesting that this was present at least as an impurity. However the two peaks described as impurity in the discussion of the  $[\text{Fe}_4(\text{CO})_{13}\text{H}]^-$  ion were always present as well-resolved unbroadened lines in positions ( $\delta = 0.32$ ,  $\Delta = 2.20 \text{ mm. sec}^{-1}$ ) which have not been observed for any of the other complexes studied in this work. It is therefore concluded that these peaks, at least, arise from  $\text{H}_2\text{Fe}_4(\text{CO})_{13}$ . The quadrupole splitting of these peaks is very large and the same as was observed for  $[\text{Fe}_2(\text{CO})_8]^{2-}$ , suggesting that one iron atom in  $[\text{HFe}_4(\text{CO})_{13}]^-$  is very strongly affected by the addition of a second proton. The other three iron atoms in the hydride are only changed slightly since they overlap with those arising from the hydrido-anion. This evidence is suggestive that the second hydrogen atom is terminally bound to the apical iron atom of  $[\text{Fe}_4(\text{CO})_{13}\text{H}]^-$ , but in the absence of data obtained from a pure sample, this conclusion can only be tentative.

#### 4. Discussion

These results show particularly clearly how the techniques of

Mossbauer and infrared spectroscopy can complement each other in providing a great deal of structural information about iron carbonyl complexes. In all cases, except possibly the ion  $[\text{Fe}(\text{CO})_4]^{2-}$ , the structural conclusions are based on arguments requiring information from both sources. Generally, neither technique was definitive without the other. Thus, for the polynuclear complexes, while Mossbauer data was the more informative, consideration of bridging carbonyl C-O stretching frequencies were especially useful. For the simpler systems, while group theory was often successful in interpreting the infrared spectra, a more accurate picture of small distortions and interactions was possible from the Mossbauer data.

While this work has been in progress, certain trends and regularities have become apparent, especially in the Mossbauer spectra. The parameters for all the species studied, together with those for the parent iron carbonyls<sup>61</sup> are shown in Fig.9-14 in the form of a correlation diagram.

The most obvious regularity, which applies for all the species except  $\text{Fe}(\text{CO})_4\text{H}_2$ , is that there is a reduction in isomer shift as the number of negative charges on the metal cluster increases - the most striking illustration of this behaviour is given by the dinuclear system, as shown in Table 9-7. This behaviour is readily understood if it is assumed that the electrons responsible for the charge are in orbitals of partly 4s character, or that as the negative

FIG. 9-14

Correlation diagram for carbonyl and hydrido-carbonyl species of

Iron.

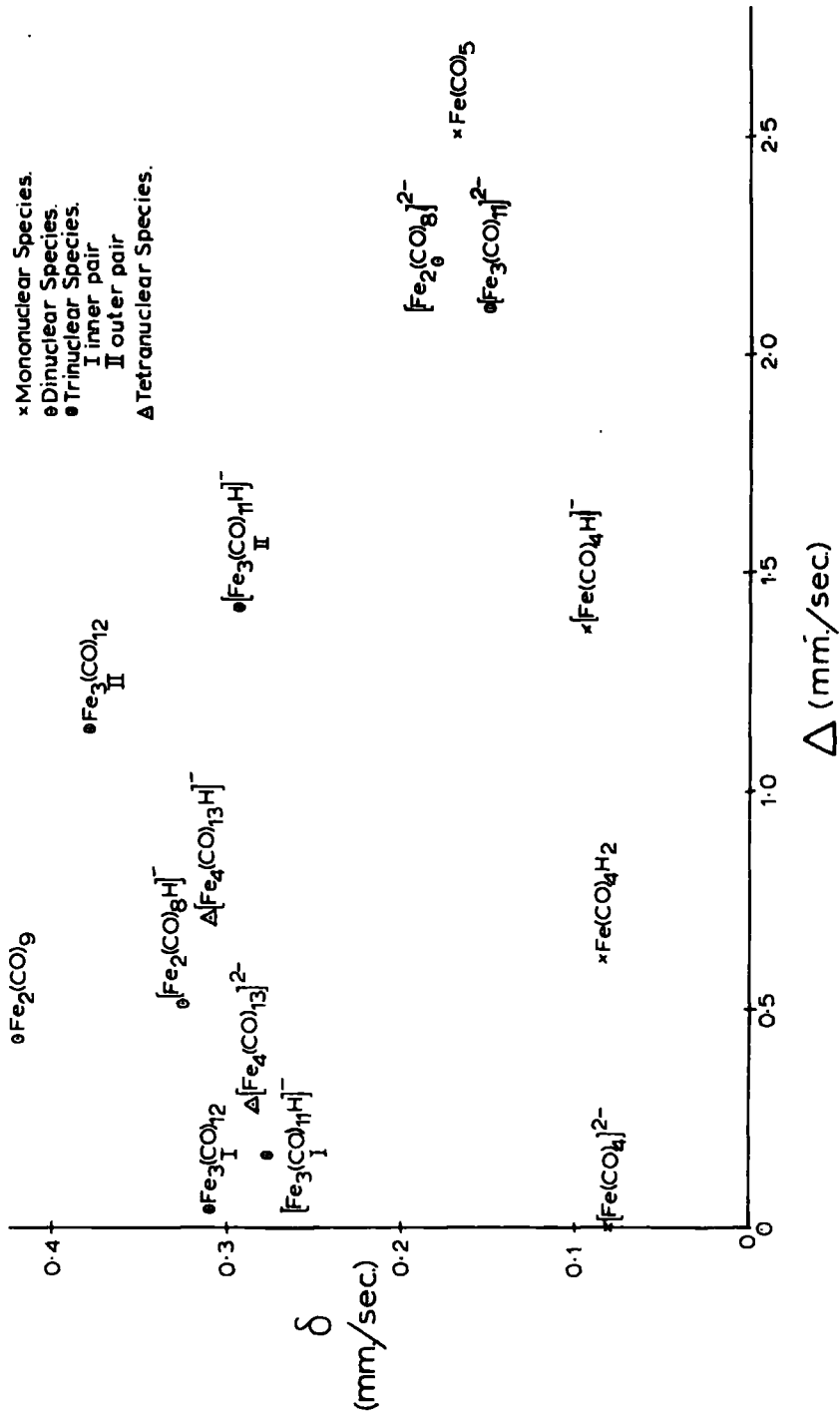


Table 9-7

Species	$\text{Fe}_2(\text{CO})_9$	$[\text{Fe}_2(\text{CO})_8\text{H}]^-$	$[\text{Fe}_2(\text{CO})_8]^{2-}$
$\delta$	$0.42_0$	$0.32_5$	$0.18_0$

charge increases, there will be greater d-electron delocalisation on to the CO ligands as reflected by the reduced C-O stretching frequency for example, with consequent reduced shielding of s-electrons from the nucleus. In each case, the increased s-electron density at the nucleus will result in a reduced isomer shift, and it is not possible to decide which is the predominant mechanism (if one does predominate) without having full theoretical treatments of each ion or molecule available.

The parameter  $\Delta$ , which arises from the interaction of the nuclear quadrupole moment with the electric field gradient at the nucleus, is a very sensitive measure of the environment of the iron atom, but care must be exercised in the interpretation of splittings because similar e.f.g.'s can be produced by two different environments. However, small changes in either of the environments will be reflected by a change in  $\Delta$ . An example of this dual dependence of quadrupole splitting on the environment is shown in the tetranuclear series. As explained earlier, the basal iron atoms of  $[\text{Fe}_4(\text{CO})_{13}]^{2-}$  should be different from the apical one. The e.f.g.'s produced at

these iron atoms are apparently the same, however, and so the iron atoms are indistinguishable. Similarly, when the hydrogen atom sits inside the tetrahedron it affects the e.f.g.'s about equally, so that the iron atoms are still indistinguishable, but the presence of the hydrogen is reflected by a change in  $\Delta$ . In fact, it more than doubles in value from  $0.27 \text{ mm. sec}^{-1}$  for  $[\text{Fe}_4(\text{CO})_{13}]^{2-}$  to  $0.70 \text{ mm. sec}^{-1}$  for  $[\text{Fe}_4(\text{CO})_{13}\text{H}]^-$ .

One of the most interesting regularities shown by this series of compounds is that replacement of a bridging CO group by a hydride ligand increases the quadrupole splitting but reduces the isomer shift of the relevant iron atoms. The changes in these parameters for the dinuclear system and the bridged atoms of  $\text{Fe}_3(\text{CO})_{12}$  and  $[\text{Fe}_3(\text{CO})_{11}\text{H}]^-$  are shown in Table 9-8.

Table 9-8

	$\delta$	Change in $\delta$	$\Delta$	Change in $\Delta$
$\text{Fe}_3(\text{CO})_{12}$	0.37		1.13	
$[\text{Fe}_3(\text{CO})_{11}\text{H}]^-$	0.29	-0.08	1.41	+0.28
$\text{Fe}_2(\text{CO})_9$	0.42		0.42	
$[\text{Fe}_2(\text{CO})_8\text{H}]^-$	0.33	-0.09	0.50	+0.08

The isomer shift is also reduced when a terminal CO group is replaced by a hydride ligand, as shown by the change in  $\delta$  on going from  $\text{Fe}(\text{CO})_5$  ( $\delta = 1.7$ ) to  $[\text{Fe}(\text{CO})_4\text{H}]^-$  ( $\delta = 0.95$ ). This tendency for  $\delta$  to

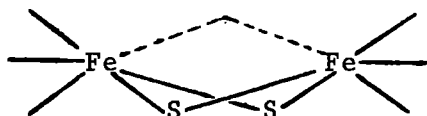
become more negative has been rationalised<sup>22</sup> in terms of partial donation of iron  $\sigma(d)$  electrons towards the hydrogen, thus completing the formal charge assignment of -1 for the hydride ligand, but could equally well be due to the ability of the CO ligands to remove part of the additional charge by accepting d-electron density from the metal atom.

A change in quadrupole splitting on substitution of CO by a hydride ligand would be expected, because of the different characteristics of the ligands. Thus, substitution of a terminal CO group (in  $\text{Fe}(\text{CO})_5$ ) by hydride substantially decreases  $\Delta$ , an effect which is readily rationalised in terms of the smaller size of the hydride ligand, as discussed earlier, but in a bridging position, the hydride ligand produces a slightly increased quadrupole splitting (Table 9-8). This must be a result of the different bonding characteristics of the hydrogen and carbon monoxide ligands since they both have similar stereochemical requirements in this type of bent-bridge system, as shown by the similarity of the structures of  $\text{Fe}_3(\text{CO})_{12}$ <sup>23</sup> and  $[\text{Fe}_3(\text{CO})_{11}\text{H}]^-$ .<sup>24</sup> However, a detailed interpretation of the experimental parameters is not feasible at present because a successful and detailed treatment of the effects of different bonding situations on quadrupole splitting is not available.

It has been noted before<sup>28</sup> that Mossbauer spectroscopy can be used to indicate that a metal-metal bond completes the octahedral



co-ordination-state of the iron atoms in complexes like I. In the compounds which have been the subject of this work, Fe-Fe bonds have



I

been found in a variety of different situations, and in each case their effect on the Mossbauer parameters is similar to that produced by more normal Fe-ligand bonds. Thus, for the purpose of predicting qualitatively the magnitude of the quadrupole splittings, it appears that an Fe-Fe bond can be considered to be a normal, 2-electron bond localised between the iron atoms considered. This applies for both 5- and 6-co-ordinate iron atoms, as shown in Table 9-9, in which only those iron atoms to which no weakly bound groups are attached are considered

Inspection of Table 9-9 shows that whenever a Fe-Fe bond is part of an octahedral environment, there is very little effect on the electric field gradient, so that even in the case where three mutually cis carbonyl groups and three  $\text{Fe}(\text{CO})_3$  units are the six nearest neighbours, the observed quadrupole splitting is well within the range expected for octahedrally co-ordinated iron.

Table 9-9

Iron Atom Considered	Number of Fe-Fe bonds	Environment	Observed $\Delta$ mm. sec <sup>-1</sup>	Expected <sup>*</sup> $\Delta$
Both in [Fe <sub>2</sub> (CO) <sub>8</sub> ] <sup>2-</sup>	1	Approx. trigonal bipyramidal	2.21	2-2.5
Apical in Fe <sub>3</sub> (CO) <sub>12</sub>	2	cis-octahedral	0-0.1 †	0-0.6
Apical in [Fe <sub>3</sub> (CO) <sub>11</sub> H] <sup>-</sup>	2	cis-octahedral	0.16	0-0.6
Apical in [Fe <sub>4</sub> (CO) <sub>13</sub> ] <sup>2-</sup>	3	cis-octahedral	0.27	0-0.6

\* Refers to the range of  $\Delta$  that has been observed for the environment described.

† The central line in the spectrum of Fe<sub>3</sub>(CO)<sub>12</sub> is sometimes resolved (when  $\Delta \approx 0.1$ ) under ideal conditions<sup>613</sup> - hence the range quoted.

In addition, although  $\Delta$  is very sensitive to small differences in environment, the e.f.g. produced at a given iron atom by a weakly bound group, such as a triply-bridging carbonyl group, or a hydrogen atom in the centre of a cage appears to be very small. In other words, the magnitude of  $\Delta$  is determined primarily, in such cases, by the number and type of groups to which it is strongly bonded - this number including all terminal groups, doubly-bridging carbonyl or hydride ligands and also all Fe-Fe bonds, as shown in Table 9-10.

Table 9-10

Iron Atom Considered	No. of weakly bound groups	No. of strongly bound groups	Observed $\Delta$ (mm.sec <sup>-1</sup> )	Environment implied by $\Delta$
All in $[\text{Fe}_3(\text{CO})_{11}]^{2-}$	2	5	2.1	5-co-ordinate
Basal three in $[\text{Fe}_4(\text{CO})_{13}]^{2-}$	1 (or 2)*	6	0.27	Octahedral
Apical in $[\text{Fe}_4(\text{CO})_{13}\text{H}]^-$	1	6	0.7 ‡	distorted octahedral
Basal three in $[\text{Fe}_4(\text{CO})_{13}\text{H}]^-$	2 (or 3)*	6	0.7	distorted octahedral

\* When the extremely weakly bridging CO groups (Fig.9-13) are considered, the number of weakly bound groups is given in parentheses.

‡ This figure is approximate - see discussion of this ion.

Interestingly, the largest effect of any of these weakly bound groups is caused by the hydrogen atom in  $[\text{Fe}_4(\text{CO})_{13}\text{H}]^-$ , despite being, in a sense, quadruply-bridging. A possible explanation of this behaviour may be that the hydrogen atom cannot, on purely geometrical grounds, be more than  $1.6\overset{\circ}{\text{A}}$  from each iron atom<sup>84</sup> - i.e. a normal terminal M-H bond distance.<sup>86</sup>

## APPENDIX I

### Experimental Details and Starting Materials

Most of the reactions which have been described were carried out in an atmosphere of pure, dry nitrogen either in two-necked flasks or in double Schlenk tubes. Air-sensitive materials were transferred from one vessel to another in a glove box or, if in solution by syringe against a counter-current of nitrogen.

### Nitrogen Supply

"White Spot" nitrogen from the bench supply was passed through a furnace containing 'BTS' catalyst at 100-120<sup>o</sup>, to remove traces of oxygen. The gas was then dried by passage through a trap maintained at -196<sup>o</sup> and delivered to a multiple outlet-system. A constant pressure of nitrogen was maintained in the system by connecting one of the outlets to an oil bubbler. The catalyst was regenerated when necessary by passing hydrogen through the furnace.

### Glove Box

The nitrogen atmosphere in the glove box was purified by continuously recycling it through a trap at -196<sup>o</sup>, through two furnaces at 400<sup>o</sup> containing copper wire, and back to the box via a second trap at -196<sup>o</sup>. Bench nitrogen was used, after passage through this system, to flush out the transfer tube. All external tubing was of copper or glass, and the gloves used were made of "Butasol" rubber.

An oxygen level of less than 50 p.p.m. was maintained by this system.

### Solvents

All solvents were degassed on the vacuum line before use.

Hydrocarbon solvents were dried over sodium wire. Chloroform and dichloromethane were refluxed with  $P_2O_5$  before distillation. Benzene, monoglyme, THF and ether were used freshly distilled under nitrogen from  $LiAlH_4$ . Nitrobenzene for conductivity measurements was dried over  $MgSO_4$  before being fractionated under vacuum using a 4' column of glass helices.

### Starting Materials

The large majority of the metal carbonyl derivatives used as starting materials are readily available by methods in the literature or the method used has been described in the text. The preparation of the sodium salt  $\text{Na}[\text{C}_5\text{H}_5\text{Mo}(\text{CO})_3]$  has also been described in the text, as has the preparation of metal derivatives (metal = Na, Li, MgBr) of diphenylketimine.

### Cyclopentadiene

Commercial dicyclopentadiene was thoroughly dried over  $\text{MgSO}_4$  before being introduced to the "cracker". This consisted of a 1 l. 3-necked flask, containing tetralin (400 ml.), equipped with a dropping funnel, nitrogen inlet and thermometer, and a warm water condenser which led, via a glass U-tube, to a cold water condenser and the collection vessel.

The whole system was slowly purged during operation with nitrogen which was dried by passage through a trap maintained at  $-196^\circ$ .

When the tetralin was refluxing gently ( $220^\circ$ ), the dicyclopentadiene was added dropwise from the funnel. The cyclopentadiene produced was carried in the nitrogen stream past the warm water condenser (which stopped tetralin) into the cold water condenser and thence to the collection flask.

### Benzophenone N-bromimine, $\text{Ph}_2\text{C}=\text{NBr}$

This compound was made by the method of Theilacker and Fauser

(Ann. 1939, 539, 103). Diphenylketimine hydrochloride (13 g.) was added to a freshly prepared aqueous solution of hypobromous acid at  $-3^{\circ}\text{C}$  (HOBr solution made at  $-3^{\circ}$  by adding  $\text{Br}_2$  (39 g.) to a solution of  $\text{Na}_2\text{CO}_3$  (25.5 g.) in water (375 ml.), followed by the addition of  $\text{K}_2\text{CO}_3$  (6 g.)). The product was extracted into chloroform and the solvent, which contained excess bromine, removed on a rotary evaporator. The yellow oil resulting was recrystallised from hexane at  $-78^{\circ}$  as a very pale yellow crystalline solid. Yield, 11.5 g. (74%). M.Pt.,  $37-8^{\circ}$  (Lit.  $38.5^{\circ}$ ).

N-(trimethylsilyl)benzophenone imine,  $\text{Ph}_2\text{C}=\text{N}-\text{SiMe}_3$

The compound was prepared by the method developed by C. Summerford and Dr. K. Wade of this department. Diphenylketimine (46.3 ml., 276 mmole) in ether (300 ml.) was treated under nitrogen at  $-78^{\circ}$  with n-butyl lithium in hexane (276 mmole). The mixture was then warmed to room temperature and stirred for 1 hr., to ensure complete formation of  $\text{Ph}_2\text{C}=\text{NLi}$ , some of which precipitated out. Trimethylchlorosilane (32 g.) was then added at  $-78^{\circ}$ , and the mixture stirred at room temperature for 2-3 hrs. The ether and hexane were then distilled out, and the product distilled under vacuum.

Yield, 65 ml. (93%). B.Pt.,  $92-97^{\circ}$ ,  $10^{-3}$  mm.

## APPENDIX 2

### Instrumentation

#### Infrared Spectra

Infrared spectra in the range 2.5-25 microns were generally recorded on a Spectromaster, although a Grubb-Parsons GS2A prism-grating spectrophotometer was also used.

Spectra of solid samples were recorded in the form of Nujol mulls between KBr plates, the samples being made up in the glove box.

Liquid samples (usually solutions) were inserted into a solution cell (thickness generally 0.1 mm) by syringe. Gas phase spectra were recorded using a 10 cm. cell. Both cells had KBr windows.

#### Nuclear Magnetic Resonance Spectra

Nuclear magnetic resonance spectra were recorded on a Perkin-Elmer R10 spectrometer, operating at 60 Mc/sec. Samples were normally in  $\text{CCl}_4$  or  $\text{CDCl}_3$  solution. The internal reference standard in all cases was tetramethylsilane (T.M.S.). The sample tubes were filled by syringe against a counter-current of nitrogen, and were sealed under nitrogen.

#### Mass Spectra

Mass spectra were recorded on an A.E.I. MS9 mass spectrometer at 70 eV and an accelerating potential of 8 kv, with a source temperature between 100 and 300°C (depending on the sample) and electromagnetic



scanning. Compounds were introduced by direct insertion into the ion source.

Molecular Weights by Osmometry

Molecular weights were measured using a "Mecrolab Osmometer" in chloroform solution using either analytical grade biphenyl or  $\text{Cl.C}_6\text{H}_3(\text{NO})_2$  as standard solute.

### APPENDIX 3

#### Analytical Methods

##### Carbon and Hydrogen

Carbon and Hydrogen determinations were carried out by the departmental microanalyst using conventional combustion techniques.

Samples containing Nitrogen were analysed for Carbon, Hydrogen and Nitrogen by Drs. Weiler and Strauss of Oxford.

##### Halogens

Analyses for Chlorine and Bromine content were carried out by the departmental microanalyst by conventional potassium-fusion and titration methods.

##### Carbon Monoxide

Carbon monoxide was analysed volumetrically on a vacuum line equipped with a gas-burette filled with mercury. The compound was decomposed using a mixture of pyridine and iodine, the mixture being heated to 100°C to ensure complete liberation of carbon monoxide. The gases were then pumped through a trap at -196° into the gas-burette using a Toppler pump.

##### Iron

The compound was boiled with A.R. concentrated nitric acid until all the organic material had been oxidised (ammonium persulphate was often added to ensure complete removal). After digestion, the

nitric acid was gradually replaced by concentrated hydrochloric acid by adding hydrochloric acid, boiling to small bulk and repeating the process until nitric fumes no longer formed. The resulting hot hydrochloric acid solution was then treated dropwise with stannous chloride solution (30% hydrochloric acid solution) until the yellow colour was just discharged. The mixture was then cooled below 25° and a saturated aqueous solution of mercuric chloride (10 ml.) was added quickly to remove excess stannous chloride (The precipitate of  $\text{Hg}_2\text{Cl}_2$  obtained at this point should be silky-white). After 3-4 mins., the solution was diluted with water (150 ml.) and sulphuric acid (10 ml., 2.5M) was added followed by phosphoric acid (5 ml., 85%) and barium diphenylaminesulphonate indicator. This green solution containing  $\text{Fe}^{2+}$  was then titrated with approx.  $\text{M}/60$  standard potassium dichromate solution until the pure green colour showed the first permanent tinges of purple or blue-violet.

$$\% \text{Fe} = \frac{\text{Titn(ml.)} \times \text{Normality of } \text{K}_2\text{Cr}_2\text{O}_7 \times 55.85 \times 100}{1000 \times \text{wt. of sample}}$$

APPENDIX 4

Calculation of Isotope Patterns

The mass spectra of complexes of many of the transition metals are complicated by the polyisotopic nature of these elements, so that characteristic patterns are produced for each metal-containing ion which reflects the isotope abundances of the metal. Ions containing two or more polyisotopic elements produce a relatively high combined mass, extending over several mass units. The combinations for Mo<sub>2</sub> are shown below:

Isotope Combination (atomic weights)		Mass	Abundance Product
92	92	183.812579	2.51540
94	92	185.811030	2.89286
95	92	186.812010	4.98004
96	92	187.810839	5.23380
97	92	188.812030	2.99754
98	92	189.811800	7.53350
100	92	191.813860	3.05146
94	94	187.809480	0.831744
95	94	188.810460	2.86368
96	94	189.809290	3.00960
97	94	190.810480	1.72368
98	94	191.810250	4.33200
100	94	193.812310	1.75469
95	95	189.811440	2.46490
96	95	190.810270	5.18100
97	95	191.811460	2.96730
98	95	192.811230	7.45750
100	95	194.813290	3.02068
96	96	191.809100	2.72250
97	96	192.810290	3.11850
98	96	193.810060	7.83750
100	96	195.812120	3.17460
97	97	193.811480	0.893025

Isotope Combination (atomic weights)		Mass	Abundance Product
98	97	194.811250	4.48875
100	97	196.813320	1.81818
98	98	195.811020	5.64063
100	98	197.813080	4.56950
100	100	199.815140	0.925444

The abundance product is the product of isotope abundances and factorial of the total number of atoms, divided by the product of the factorial of numbers of each isotope present. For example, for  $^{92}\text{Mo}$   $^{92}\text{Mo}$ , the abundance product is, using approximate abundances

$$\frac{(1.58 \times 1.58)2!}{2!} = 2.5$$

but for  $^{92}\text{Mo}$   $^{96}\text{Mo}$ , the abundance product is

$$\frac{(1.58 \times 1.65) !}{1! \times 1!} = 5.22$$

Those combinations which have the same nominal mass (e.g.  $^{98}\text{Mo} + ^{92}\text{Mo}$ ;  $^{96}\text{Mo} + ^{94}\text{Mo}$ ;  $^{95}\text{Mo} + ^{95}\text{Mo}$ ) generally cover a mass spread of less than 50 p.p.m. (parts per million) and even with a maximum spectrometer resolution of 1:20,000 appear as a single peak corresponding to the weighted arithmetic mean of the exact masses of the contributing combinations. For example, the "precise mass" of the peak at 188 is given by:

$$\frac{187.810839 \times 5.23380 + 187.809480 \times 0.831744}{5.23380 + 0.831744}$$

$$= 187.810653$$

The peak height of this mass is proportional to the sum of the relative abundances of the individual combinations, (i.e.  $5.23380 + 0.831744$ ), so the relative abundance of any nominal mass is readily calculated as a percentage of the abundance of the most abundant mass.

Both the isotope abundance pattern, and the precise masses of the peaks for  $\text{Mo}_2$  are given below.

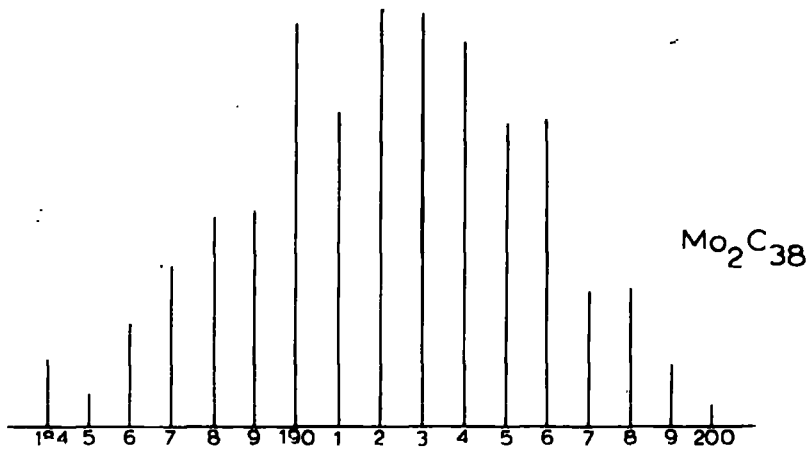
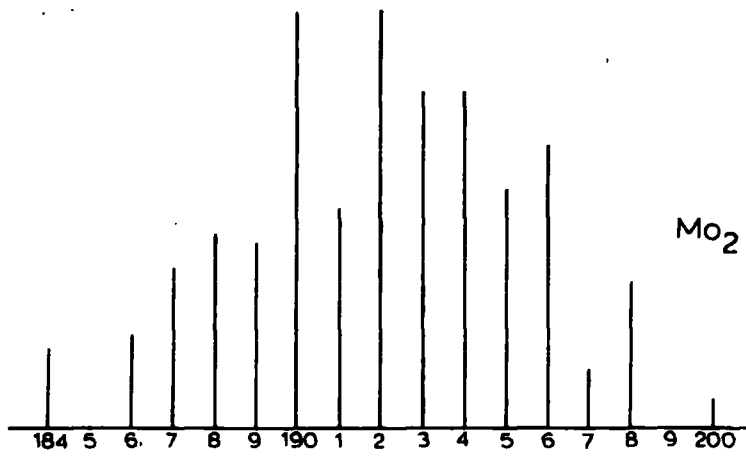
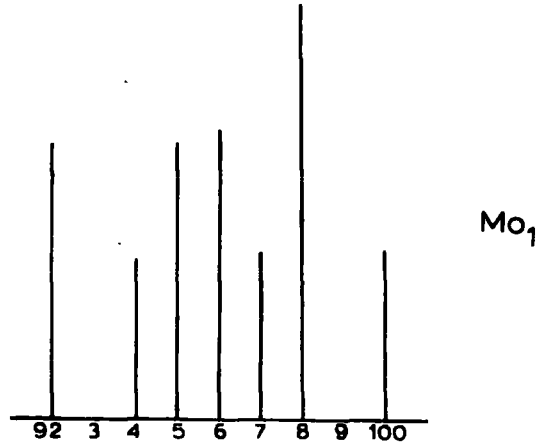
Nominal Mass	Multiplicity	Spread (ppm)	Peak Mass (wtd.mean)	Relative abundance
184	Singlet		183.812579	19.2408
185	No combination		-	-
186	Singlet		185.811030	22.1281
187	Singlet		186.812010	38.8933
188	2	7.2	187.810653	46.3966
189	2	8.3	188.811263	44.8336
190	3	13.2	189.811151	99.5008
191	2	1.1	190.810322	52.8153
192	4	25	191.811128	100.0000
193	2	4.9	192.810953	80.8979
194	3	12	193.810557	80.2035
195	2	10.5	194.812071	57.4411
196	2	5.6	195.811416	67.4294
197	Singlet		196.813310	13.9076
198	Singlet		197.813080	34.9530
199	No combination		-	-
200	Singlet		199.815140	7.0789

It will be observed that the most abundant peak does not occur at the mass numbers of the predominant molybdenum isotopes (i.e.  $^{98}\text{Mo}$ ,  $^{98}\text{Mo} = 196$ , but this is only 67% of the 192 peak), and often for combinations of elements which do not have one outstandingly predominant isotope, the integer mass of the most abundant peak does not correspond to the sum of the mass numbers of the predominant isotopes. Thus, the characteristic patterns produced by ions containing a polyisotopic metal or metals allow immediate recognition of these ions, and the determination of the number of metal atoms in an ion from the low resolution spectrum.

Finally, for metal complexes containing a large number of carbon atoms, the effects of  $^{13}\text{C}$  on the pattern may be sufficient to alter the visual appearance of the patterns. (the lower limit of this effect is for about 15 carbon atoms).  $^{13}\text{C}$  has a 1% natural abundance, so for n carbon atoms, approximately n% of the peak height for given nominal mass will occur one mass unit higher. For example, for an  $\text{Mo}_2$  species containing 38 carbon atoms, 38% of the abundance of one nominal mass has to be added to the next nominal mass. The complex  $[\text{C}_5\text{H}_5\text{Mo}(\text{CO})\text{N}=\text{CPh}_2]_2$  is such a species, so the pattern expected for this ion, corrected for  $^{13}\text{C}$  is shown overleaf.

FIG-A1

Isotope Distribution Patterns for  $Mo_1$ ,  $Mo_2$  and  $^{13}C$ -corrected  $Mo_2C_{38}$ .





Nominal Mass	Corrected Abundance as % of 192
184	16.0
185	7.3
186	24.5
187	38.7
188	50.7
189	52.0
190	97.1
191	75.5
192	100
193	99.0
194	92.4
195	73.2
196	74.3
197	33.0
198	33.5
199	15.3
200	5.9

To illustrate this behaviour pictorially, the isotope patterns for (i) one molybdenum atom, (ii) two molybdenum atoms and (iii) two molybdenum atoms and thirty eight carbon atoms are shown in Fig.A-1.

## References for Part I

1. J. Chatt, P.L. Pauson and L.M. Venanzi in "Organometallic Chemistry" H. Zeiss Ed., Reinhold, New York, 1960 p.468.
2. E.W. Abel. Quart. Rev., 1963, 17, 133.
3. F. Calderazzo, R. Ercoli and G. Natta. Ref.14 p.1.
4. W. Hieber, W. Beck and G. Braun. Angew. Chem., 1960, 72, 795.
5. R.B. King in "Adv. in Organomet. Chem." Stone and West Eds., 1964, 2, 157.
6. M.A. Bennett. Chem. Revs., 1962, 62, 611.
7. R.G. Guy and B.L. Shaw. "Adv. in Inorganic and Radiochem." 1962, 4, 77.
8. R. Pettit and G.F. Emerson. "Adv. in Organomet. Chem." Stone and West Eds., 1964, 1 pl.
9. P.M. Treichel and F.G.A. Stone. *ibid.* p.143.
10. E.O. Fischer and H.P. Fritz. "Adv. Inorg. and Radiochem." 1959, 1, 56.
11. G. Wilkinson and F.A. Cotton. Progr. Inorg. Chem., 1959, 1,1.
12. E.W. Abel and B.C. Crosse. Organometal. Chem. Rev., 1967, 2,443.
13. T.A. Manuel. "Adv. in Organometal. Chem." Stone and West Eds., 1965, 3, 181.
14. "Organic Syntheses via Metal Carbonyls". I. Wender and P. Pino Eds., Interscience, Vol.1, 1968. (Vol.2 to be published).
15. T.A. Manuel. Inorg. Chem., 1963, 2, 845.
16. J. Lewis, R.S. Nyholm, A.G. Osborne, S.S. Sandhu and M.H.B. Stiddard. Chem. and Ind. (London) 1963, 1398.
17. M. Ahmad, R. Bruce and G.R. Knox. J. Organomet. Chem., 1966, 6, 1.
18. W. Hieber and W. Beck. Z. Anorg. Allgem. Chem., 1960, 305, 265.
19. L.F. Dahl and C.H. Wei. Inorg. Chem., 1963, 2, 328.
20. T.C. Gibb, R. Greatrex, N.N. Greenwood and D.T. Thompson. J.C.S.(A), 1967, 1663.
21. S. Ahrland, J. Chatt and N.R. Davies. Quart. Rev., 1958, 12, 265.
22. L.E. Orgel. "An Introduction to Transition Metal Chemistry: Ligand Field Theory". Wiley, New York, 1960.

23. F.A. Cotton. "Chemical Applications of Group Theory". Wiley, New York, 1963.
24. D.W.A. Sharp. Proc. Chem. Soc., 1960, 317.
25. C.K. Jørgenson. "Inorganic Complexes" Academic Press, 1963, p.36.
26. E. Pitcher and F.G.A. Stone. Spectrochim. Acta., 1962, 18, 585.
27. R.B. King and F.G.A. Stone. Inorg. Synth., 1963, 7, 104.
28. F.A. Cotton. Quart. Rev., 1960, 20, 394.
29. Ref. 14 and references therein.
30. W.R. Cullen and R.G. Hayter. J.A.C.S., 1964, 86, 1030.
31. Ref.12. p.455.
32. A.G. Osborne and F.G.A. Stone. J.C.S. (A), 1966, 1143.
33. E.W. Abel, A.M. Atkins, B.C. Crosse and G.V. Hutson. Unpub. quoted in ref.12 p.450.
34. F.A. Cotton and G. Wilkinson. "Advanced Inorg. Chem." 2nd Edn. Interscience, 1966, p.156.
35. A. Wojcicki and F. Basolo. J.A.C.S., 1961, 83, 525.
36. R.J. Anjelici and F. Basolo. J.A.C.S., 1962, 84, 2495.
37. F. Zingales, M. Graziani, F. Faraona and U. Belluco. Inorg. Chim. Acta., 1967, 1, 172.
38. H.C.E. Mannerskantze and G. Wilkinson. J.A.C.S., 1962, 84, 4454.
39. R.B. King. "Organomet. Synth." 1965, 1, 179.
40. W. Hieber, J. Peterhans and E. Winter. Chem. Ber., 1961, 94, 2572.
41. W. Hieber and E. Winter. *ibid.* 1964, 97, 1037.
42. R.P.M. Werner. Z. Naturforsch., 1961, 166, 477.
43. A.S. Kasenally, R.S. Nyholm, R.J. O'Brien and M.H.B. Stiddard. Nature, 1964, 204, 871.
44. R.B. King. J.A.C.S., 1963, 85, 1587.
45. R.H. Holm, R.B. King and F.G.A. Stone. Inorg. Chem., 1963, 2, 219.
46. H. Behrens and H. Zizlsperger. Z. Naturforsch., 1964, 16b, 349.
47. H. Behrens and D. Hermann. Z. Naturforsch., 1966, 21b, 1236.
48. R. Cotton and I.B. Tomkins. Aust. J. Chem., 1966, 19, 1143.
49. R. Cotton and I.B. Tomkins. Aust. J. Chem., 1966, 19, 1519.
50. R. Cotton and I.B. Tomkins. Aust. J. Chem., 1967, 20, 9 and 13.

51. J. Chatt and D.A. Thornton. J.C.S., 1964, 1005.
52. J. Chatt and D.T. Thompson. J.C.S., p.2713.
53. R.G. Hayter. Inorg. Chem., 1964, 3, 711.
54. H.L. Nigam, R.S. Nyholm and M.H.B. Stiddard. J.C.S., 1960, 1806.
55. J. Lewis, R.S. Nyholm, C.S. Pande and M.H.B. Stiddard. J.C.S., 1963, 3600.
56. J. Lewis, R.S. Nyholm, C.S. Pande and M.H.B. Stiddard. J.C.S., 1964, 3009.
57. J. Lewis, R.S. Nyholm, C.S. Pande and M.H.B. Stiddard. J.C.S., p.3010.
58. J. Lewis and R. Whyman. J.C.S., 1965, 5486.
59. J. Lewis and R. Whyman. Chem. Comm., 1965, 159.
60. J. Lewis and R. Whyman. J.C.S., 1965, 6027.
61. J. Lewis and R. Whyman. J.C.S.(A), 1967, 77.
62. M.H.B. Stiddard. J.C.S., 1962, 4712.
63. H. Behrens and J. Rosenfelder. Z. Anorg. Allgem. Chem., 1967, 352, 61.
64. H.C.E. Mannerskantz and G. Wilkinson. J.C.S., 1962, 4454.
65. E.W. Abel, I.S. Butler and I.G. Reid. J.C.S., 1963, 2068.
66. A. Wojcicki and M.F. Farona. J.N.C., 1964, 26, 2289.
67. H. Behrens and J. Kohler. Z. Naturforsch, 1959, 14b, 463.
68. W. Beck and H.S. Smedal. Angew. Chem., 1966, 78, 267.
69. W. Beck, R.E. Nitzschmann and H.S. Smedal. J. Organomet. Chem., 1967, 8, 547.
70. M.F. Lappert. Personal Communication to Dr. K. Wade.
71. E.W. Abel, I.S. Butler and C.R. Jenkins. Unpub. quoted in ref.12 p.447.
72. Miss C.A. Payling and M. Kilner. Personal Communication.
73. W. Beck and H.S. Smedal. Angew. Chem. Int. Ed., 1966, 6, 253.
74. Th.Kruck and K. Noack. Chem. Ber., 1964, 97, 1693.
75. K. Issleib and W. Kratz. Z. Naturforsch, 1965, 20b, 1303.
76. H. Behrens and N. Harder. Chem. Ber., 1964, 97, 433.
77. J.M. Birmingham. "Adv. Organomet. Chem." Stone and West Eds., 1964, 2, 365.

78. This Thesis page 96.
79. R.G. Hayter. *Inorg. Chem.*, 1963, 2, 1031.
80. W. Hieber and H. Tengler. *Z. Anorg. Allgem. Chem.*, 1962, 318, 136.
81. L.F. Dahl and R.J. Doedens. *J.A.C.S.*, 1965, 87, 2576.
82. R.B. King. *J.A.C.S.*, 1963, 85, 1587.
83. P.M. Treichel, J.H. Morris and F.G.A. Stone. *J.C.S.*, 1963, 720.
84. R. Havlin and G.R. Knox. *Z. Naturforsch*, 1966, 21b, 1108.
85. C.G. Hull and M.H.B. Stiddard. Unpublished quoted in ref.12 p.449.
86. H.D. Murdock and R. Henzi. *J. Organomet. Chem.*, 1966, 5, 552.
87. R.B. King and M.B. Bisnette. *Inorg. Chem.*, 1966, 5, 300.
88. E.W. Abel and G. Wilkinson. *J.C.S.*, 1959, 1501.
89. W. Hieber, F. Lux and C. Herget. *Z. Naturforsch*, 1965, 20b, 1159.
90. H. Sohullen. *Z. Anorg. Allgem. Chem.*, 1939, 243, 164.
91. E.O. Brimm, M.A. Lynch and W.J. Sesney. *J.A.C.S.*, 1954, 76, 3831.
92. W. Hieber, R. Schuh and H. Fuchs. *Z. Anorg. Allgem. Chem.*, 1941, 248, 243.
93. A. Wojcicki and M. Faron. *Inorg. Chem.*, 1965, 4, 1402.
94. A. Wojcicki and M. Faron. *Inorg. Chem.*, 1965, 4, 857.
95. L.M. Venanzi. *J.C.S.(A)*, 1966, 417.
96. W. Beck, R. Nitzschmann and G. Neumair. *Angew. Chem. Int. Ed.*, 1964, 5, 380.
97. C.C. Addison, M. Kilner and A. Wojcicki. *J.C.S.*, 1961, 4839.
98. F.A. Hartman and A. Wojcicki. *J.A.C.S.*, 1966, 88, 844.
99. E.W. Abel, G.B. Hargreaves and G. Wilkinson. *J.C.S.*, 1958, 3149.
100. W. Hieber and W. Schropp. *Z. Naturforsch*, 1959, 14b, 460.
101. W. Hieber, F. Lux and C. Hergel. *Z. Naturforsch*, 1965, 20b, 1159.
102. W. Hieber and L. Schuster. *Z. Anorg. Allgem. Chem.*, 1956, 285, 205.
103. P.M. Treichel, J.H. Morris and F.G.A. Stone. *J.C.S.* 1963, 720.
104. E.W. Abel, B.C. Crosse and G.V. Hutson. *J.C.S.(A)*, 1967, 2014.
105. E.W. Abel and I.H. Sabherwal. *J. Organomet. Chem.*, 1967, 10, 491.
106. H.J. Emeleus and J. Grobe. *Angew. Chem.*, 1962, 74, 467.
107. J. Grobe. *Z. Anorg. Allgem. Chem.*, 1964, 331, 63.

108. F.G.A. Stone and O. Osborne. J.C.S.(A), 1966, 1143.
109. W. Hieber and L. Schuster. Z. Anorg. Allgem. Chem., 1956, 285, 205.
110. W. Hieber and W. Freyer. Chem. Ber., 1959, 92, 1767.
111. R. Lambert. Chem. and Ind., 1961, 830.
112. A.G. Osborne and F.G.A. Stone. Chem. Comm., 1965, 361.
113. E.W. Abel, B.C. Crosse and D.B. Brady. J.A.C.S., 1965, 87, 4397.
114. M. Ahmad, G.R. Knox, F.J. Preston and R.I. Reed. Chem. Comm., 1967, 138.
115. P.S. Braterman. Chem. Comm., 1968, 91.
116. W. Hieber and G. Gscheidmeier. Z. Naturforsch., 1966, 21b, 1237.
117. E.W. Abel and I.S. Butler. J.C.S., 1964, 434.
118. E.W. Abel, I.S. Butler, M.C. Ganorkar, C.R. Jenkins and M.H.B. Stiddard. Inorg. Chem., 1966, 5, 25.
119. Ref.13 p.224-237 and refs. therein.
120. W. Hieber and G. Bader. Chem. Ber., 1928, 61, 1717.
121. W. Hieber and H. Stallmann. Chem. Ber., 1942, 75, 1472.
122. W. Hieber and A. Wirsching. Z. Anorg. Allgem. Chem., 1940, 245, 35.
123. W. Hieber and G. Bader. Z. Anorg. Allgem. Chem., 1930, 190, 193.
124. A. Wojcicki and M. Farona. Abs. of Papers. 147th A.C.S. Meeting 1964.
125. E. Weiss. Z. Anorg. Allgem. Chem., 1956, 287, 223.
126. M.A. Bennett and R.J.H. Clark. J.C.S., 1964, 5560.
127. L.A.W. Hales and R.J. Irving. J.C.S. (A), 1967, 1932.
128. F. L'Eplattenier and F. Calderazzo. Inorg. Chem., 1967, 6, 2082.
129. W. Hieber and H. Lagally. Z. Anorg. Allgem. Chem., 1940, 245, 295.
130. W. Manchot and Konig. Chem. Ber., 1924, 57, 2130.
131. R.J. Irving. J.C.S. 1956, 2879.
132. W. Hieber and W. Hensinger. J.N.C., 1957, 4, 179.
133. Ref.13 pp.230-233.
134. M. Bigorgne and M. Pankowski. Compt. Rend. Ser. C. 1966, 239.
135. E.W. Abel, I.S. Butler and C.R. Jenkins. J. Organometal. Chem. 1967, 8, 382.
136. F.A. Cotton and G. Parrish. J.C.S., 1960, 1440.

137. M.J. Cleare and W.P. Griffith. Chem. and Ind., 1967, 1705.
138. J. Chatt and D.A. Thornton. J.C.S., 1964, 1005.
139. B.E. Job, R.A.N. McLean and D.T. Thompson. Chem. Comm., 1966, 895.
140. G.R. Davies, R.H.B. Mais, P.G. Owston and D.T. Thompson. J.C.S.(A), 1968, 1251.
141. L.F. Dahl and P.W. Sutton. Inorg. Chem., 1963, 2, 1067.
142. C.H. Wei and L.F. Dahl. Inorg. Chem., 1965, 4, 493.
143. C.H. Wei and L.F. Dahl. Inorg. Chem., 1965, 4, 1.
144. J.M. Coleman, A. Wojcicki, P.J. Pollick and L.F. Dahl. Inorg. Chem., 1967, 6, 1236.
145. R.B. King. J.A.C.S., 1963, 85, 1587.
146. T.S. Piper, F.A. Cotton and G. Wilkinson. J.N.C., 1955, 1, 165.
147. B.F. Hallam and P.L. Pauson. J.C.S., 1956, 3030.
148. This thesis Ch.2.
149. R.B. King. Organomet. Syn., 1965, 1, 180.
150. R.G. Hayter. J.A.C.S., 1963, 85, 3120.
151. R.G. Hayter and R.H. Herber. J.A.C.S., 1964, 86, 301.
152. R.G. Hayter and W.R. Cullen. J.A.C.S., 1964, 86, 1030.
153. Ref.12. pp.454-455.
154. J.P. Bibler and A. Wojcicki. J.A.C.S., 1964, 86, 5051.
155. J.P. Bibler and A. Wojcicki. J.A.C.S., 1964, 88, 4862.
156. E.O. Fischer and E. Mosser. J. Organomet. Chem., 1965, 3, 16.
157. R.G. Hayter and L.F. Williams. Inorg. Chem., 1964, 3, 613.
158. M.L.H. Green and W.E. Lindsel. J.C.S.(A), 1967, 686.
159. P.L. Pauson and A.R. Qazi. J. Organomet. Chem., 1967, 7, 321.
160. P.L. Pauson and A.R. Qazi and B.W. Rockett. J. Organomet. Chem., 1967, 7, 325.
161. F. Seel and V. Sperber. Angew. Chem., Int. Ed. 1968, 7, 70.
162. M. Bigorgne and M. Pankowski. C.R. Acad. Sci. Paris, 1967, 246, 1382.
163. W. Hieber and H. Duchatsch. Chem. Ber., 1965, 98, 2530.
164. A. Sacco. Gazz. Chim. Ital., 1963, 93, 542.
165. H. Schulten. Z. Anorg. Allgem. Chem., 1939, 243, 145.

166. R.G. Hayter. J.A.C.S., 1964, 86, 823.
167. W. Hieber and P. Spacu. Z. Anorg. Allgem. Chem., 1937, 233, 353.
168. S.A. Khattab, L. Marko, G. Bor and B. Marko. J. Organomet. Chem., 1964, 1, 373.
169. L. Marko, G. Bor, E. Klumpp, B. Marko and G. Almasy. Chem. Ber., 1963, 96, 955.
170. E. Klumpp, L. Marko and G. Bor. Chem. Ber., 1964, 97, 926.
171. G. Bor, E. Klumpp and L. Marko. Chem. Ber., 1967, 100, 1451.
172. L.F. Dahl, D.L. Stevenson and V.R. Magnuson. J.A.C.S., 1967, 89, 3727.
173. L. Marko and G. Bor. Angew. Chem., 1963, 75, 248.
174. L. Marko, G. Bor and E. Klumpp. Proc. 8th ICCV Vienna 1964, 260.
175. L.F. Dahl. Unpublished quoted in ref.12. p.446.
176. L.F. Dahl. Unpublished quoted in ref.12. p.456.
177. G. Bor. J. Organomet. Chem., 1968, 11, 207.
178. R.F. Heck. Inorg. Chem., 1965, 4, 855.
179. R.B. King. Inorg. Chem., 1966, 5, 82.
180. R.G. Hayter and L.F. Williams. J.N.C., 1964, 26, 1944.
181. R.B. King, P.M. Treichel and F.G.A. Stone. J.A.C.S., 1960, 82, 4557.
182. Ref.14.
183. G.F. Svatos and E.E. Flagg. Inorg. Chem., 1965, 4, 422.
184. T. Kruck and K. Bauer. Angew. Chem. Int. Ed., 1965, 4, 521.
185. G. Booth, J. Chatt and P. Chini. Chem. Comm., 1965, 639.
186. C.E. Coffey, J. Lewis and R.S. Nyholm. J.C.S., 1964, 1741.
187. R.G. Hayter. Inorg. Chem., 1964, 3, 711.
188. K. Issleib and W. Rettkowski. Z. Naturforsch. 1966, 21b, 999.
189. E.O. Fischer and C. Palm. Chem. Ber., 1958, 91, 1725.
190. G.R. Knox, P. Bladon and R. Bruce. Chem. Comm., 1965, 557.
191. R. Havlin and G.R. Knox. Z. Naturforsch, 1966, 21b, 1108.
192. L. Malatesta and L. Naldini. Gazz. Chim. Ital., 1960, 90, 1505.
193. A.D. Helmann and M. Baumann. Compt. Rend. Acad. Sci U.S.S.R., 1938, 18, 645.
194. R.J. Irving and E.A. Magnusson. J.C.S., 1956, 1860.



195. R.J. Irving and E.A. Magnusson. J.C.S., 1957, 2018.
196. G. Booth and J. Chatt. Proc. Chem. Soc., 1961, 67.
197. J. Chatt, N.P. Johnson and B.L. Shaw. J.C.S., 1964, 1662.
198. L. Malatesta and C. Cariello. J.C.S., 1958, 2323.
199. A.R. Brause, M. Rycheck and M. Orchin. J.A.C.S., 1967, 89, 6500.
200. E.O. Fischer and A. Vogler. J. Organomet. Chem., 1965, 3, 161.
201. W. Manchot and J. Konig. Chem. Ber., 1926, 59, 883.
202. M.C. Baird and G. Wilkinson. Chem. Comm., 1966, 514.
203. Ref. 12 and references therein.
204. R.B. King. J.A.C.S., 1963, 85, 1584.
205. R.B. King and M.B. Bisnette. J.A.C.S., 1964, 86, 1267.
206. J. Cooke, M. Green and F.G.A. Stone. Unpub. 1966 quoted in ref.12 p.454.
207. E.W. Abel, B. Crosse and T.J. Leadham. Unpub. 1966 quoted in ref.12 p.454.
208. M. Ahmad, R. Bruce and G.R. Knox. Z. Naturforsch, 1966, 21b, 289.
209. R. Bruce and G.R. Knox. J. Organomet. Chem., 1966, 6, 67.
210. G.B. Barlin and D.D. Perin. "Strength of Organic Acids" Quart. Revs., 1966, 76.
211. K. Noack. Helv. Chim. Acta., 1962, 45, 1847.
212. A.P.I. Infrared Index No.1296.
213. R.B. King. J.A.C.S., 1968, 90, 1412.
214. R.B. King. J.A.C.S., 1968, 90, 1417.
215. R.B. King. J.A.C.S., 1968, 90, 1429.
216. A. Carrick. Ph.D. Thesis. University of Durham, 1967 and refs. therein.
217. W. Hieber and P. Spacu. Z. Anorg. Allgem. Chem., 1937, 233, 353.
218. R.B. King and M.B. Bisnette. Inorg. Chem., 1965, 4, 1663.
219. W. Hieber and G. Wagner. Z. Naturforsch, 1957, 12b, 278.
220. W. Hieber, G. Faulhaber and F.Z. Theubert. Z. Naturforsch, 1960, 15b, 326.
221. W. Hieber. Angew. Chem., 1963, 49, 463.

222. W. Hieber and W. Hubel. Z. Elektrochem., 1953, 57, 331.
223. F. L'Eplattenier and F. Calderazzo. Inorg. Chem., 1967, 6, 2092.
224. A.P. Ginsberg. "Hydride Complexes of the Transition Metals" in Transition Metal Chemistry. R.B. Carlin Ed., 1965, 1, 111.
225. F.G.A. Stone. "Adv. in Chem. Coord. Compounds". S. Kirschner Ed. 1961, p.619.
226. W. Hieber and E. Lindner. Chem. Ber., 1961, 94, 1417.
227. W. Hieber and E. Winter and E. Schubert. Chem. Ber., 1962, 95, 3070.
228. H. Reihlen, A. Gruhl and G. von Hessling. Ann. Chem., 1929, 472,268.
229. W. Hieber and C. Scharfenberg. Ber., 1940, 73, 1012.
230. W. Hieber and P. Spacu. Z. Anorg. Allgem. Chem., 1937, 233, 353.
231. S.F.A. Kettle and L.E. Orgel. J.C.S., 1960, 3890.
232. R.B. King, P.M. Treichel and F.G.A. Stone. J.A.C.S., 1961, 83,3600.
233. R.B. King. J.A.C.S., 1962, 84, 2460.
234. R.B. King. Organomet. Synth., 1965, 1, 180.
235. R.B. King and M.B. Bisnette. Inorg. Chem., 1965, 4, 482.
236. R.L. Downs, A. Wojcicki and P.J. Pollick. Abst. 148th A.C.S. Meeting, 1964 p.31.
237. K. Edgar, B.F.G. Johnson, J. Lewis, I.G. Williams and J.M. Wilson. J.C.S.(A), 1967, 379.
238. Ref.13. p.195.
239. W. Hieber and W. Beck. Z. Anorg. Allgem. Chem., 1960, 305, 265.
240. M. Ahmad, R. Bruce and G.R. Knox. Z. Naturforsch, 1966, 21b, 289.
241. e.g. R.B. King. J.A.C.S., 1966, 88, 2075; J. Lewis et al., J.C.S.(A), 1966, 1663.
242. F.A. Cotton and R.V. Parish. J.C.S., 1960, 1440.
243. A.F. Clifford and A.K. Mukherjee. Inorg. Chem., 1963, 2, 151.
244. Ref.224.
245. Ref.14 pp.405-467.
246. E.A.V. Ebsworth. Chem. Comm., 1966, 530.
247. L-H.Chan and E.G. Rochow. J. Organometal. Chem., 1967, 9, 231.
248. Ref.13 p.191.
249. D. Bright and O.S. Mills. Chem. Comm., 1967, 245.
250. P.E. Baikie and O.S. Mills. Chem. Comm., 1966, 707.

251. O.S. Mills, P.L. Pauson, M.M. Bagga and P.E. Baikie. Chem. Comm., 1967, 1106.
252. P.E. Baikie and O.S. Mills. Chem. Comm., 1967, 1228.
253. P.L. Pickard and T.L. Tolbert. J. Org. Chem., 1961, 26, 4886.
254. B. Bogdanovic. Angew. Chem. Int. Ed., 1965, 4, 9544.
255. I. Pattison and K. Wade. J.C.S.(A), 1967, 1098.
256. P.L. Pickard and G.W. Polly. J.A.C.S., 1954, 76, 5169.
257. B.K. Wyatt. Personal Communication.
258. J.R. Jennings, J.E. Lloyd and K. Wade. J.C.S., 1965, 2662 and 5083.
259. M.F. Lappert and B. Prokai. Adv. Organomet. Chem., 1967, 5, 225.
260. Ref.14. Vol.1 pp.245-249.
261. K.K. Joshi, P.L. Pauson and W.H. Stubbs. J. Organomet. Chem., 1963, 1, 51.
262. J.B. Wilford, P.M. Treichel and F.G.A. Stone. J. Organomet. Chem., 1964, 2, 119.
263. Ref.13. pp.217-221 and refs. therein.
264. M. Kilner. Ph.D. Thesis. University of Nottingham. 1963, p.93.
265. G.W.A. Fowles and D.K. Jenkins. Inorg. Chem., 1964, 3, 257.
266. Miss C.A. Payling and M. Kilner. Personal Communication.
267. A. Misona, T. Osa and S. Koda. Bull. Chem. Soc., Japan, 1968, 41,373.
268. K. Wade, J.R. Jennings, I. Pattison and B.K. Wyatt. J.C.S.(A), 1967, 1608.
269. I. Pattison. Ph.D. Thesis. University of Durham, 1967, p.81.
270. P.M. Treichel, E. Pitcher, R.B. King and F.G.A. Stone. J.A.C.S., 1961, 83, 2593.
271. T.S. Piper and G. Wilkinson. J.I.N.C., 1965, 3, 108.
272. T.S. Piper, G. Wilkinson and F.A. Cotton. J.I.N.C., 1955, 1, 165.
273. T.S. Piper and G. Wilkinson. J.I.N.C., 1956, 3, 104.
274. Ref.149. p.45-49.
275. M.L.H. Green and M. Cousins. J.C.S., 1963, 889.
276. K.K. Joshi and P.L. Pauson. Proc. Chem. Soc., 1962, 326.
277. R.B. King and M.B. Bisnette. Inorg. Chem., 1964, 3, 796.
278. K. Joshi, P.L. Pauson, A.R. Qazi and W.A. Stubbs. J. Organomet. Chem., 1964, 1, 471.

279. E.O. Fischer and K. Ofele. Z. Naturforsch. 1959, 14b, 736.
280. E.O. Fischer and K. Ofele. Chem. Ber., 1960, 93, 1156.
281. H. Bock and H.t. Dieck. Chem. Ber., 1967, 100, 228.
282. S. Otsuka, T. Yoshida and A. Nakamura. Inorg. Chem., 1967, 6, 20.
283. H. Bock. Angew. Chem. Int. Ed., 1962, 1, 550.
284. H. Bock and H.t. Dieck. Chem. Ber., 1966, 99, 213.
285. K. Wade and B. Samuel. Unpublished. 1967-8.
286. D.Y. Curtin and C.G. McCarty. J. Org. Chem., 1967, 32, 223.
287. G.A. Russell and Y.R. Vinson. J. Org. Chem., 1966, 31, 1994.
288. R.E. Pearson and Y.C. Martin. J.A.C.S., 1963, 85, 354.
289. G.A. Russell, C. De Boar and K.M. Desmond. J.A.C.S., 1963, 85, 365.
290. For example (a) R.B. King. J.A.C.S., 1966, 88, 2075.  
(b) J. Lewis et al., J.C.S. (A), 1966, 1663.
291. P.C.H. Mitchell. "Oxo-species of Mo(V) and (VI)". Quart. Rev., 1966, 20, 103.
292. M. St. C. Flett. "Characteristic Frequencies of Chemical Groups in the Infrared" Elsevier, 1963, p.27.
293. D.B. Chambers. Ph.D. Thesis. University of Durham, 1968 and refs. therein.
294. R.B. King. Chem. Comm., 1967, 986.
295. R.B. King and M.B. Bisnette. J. Organomet. Chem., 1967, 8, 287.
296. F.A. Cotton. Inorg. Chem., 1965, 4, 334 and Quart. Rev., 1966 20, p.400.
297. K. Wade and co-workers. Personal Communication and ref. 268.
298. P.C.H. Mitchell. J.I.N.C., 1963, 25, 963.
299. M.L.H. Green. "Organometallic Compounds" by G.E. Coates, K. Wade and M.L.H. Green. 3rd Ed. Vol.2. p145.
300. R. Ben-Shoshan and R. Pettit. Chem. Comm., 1968, 247.
301. Ref.299 p.43.

## References for Part II

1. R.L. Mossbauer. Z. Physik, 1958, 151, 124.
2. R.L. Mossbauer. Naturwissen, 1958, 45, 538.
3. R.L. Mossbauer. Z. Naturforsch, 1959, 14a, 211.
4. E. Fluck, W. Kerler and W. Neuwirth. Angew. Chem. Int. Ed., 1963, 2, 277.
5. N.N. Greenwood. Chem. in Brit., 1967, 3, 56.
6. J.R. DeVoe and J.J. Spijkermann. Anal. Chem., 1966, 38, 382R.
7. R.H. Herber. Prog. Inorg. Chem. F.A. Cotton Ed., Interscience, 1967, 8, 1.
8. V.I. Goldanskii. "The Mossbauer Effect and its Applications in Chemistry, New York, Consultants Bureau, 1964.
9. R. Greatrex. M.Sc. Thesis, University of Newcastle, 1966.
10. R. Ingalls. Rev. Mod. Phys., 1964, 36, 351.
11. G.K. Wertheim. "Mossbauer Effect". Academic Press, 1964.
12. V.I. Goldanskii. Phys. Lett., 1963, 3, 344.
13. R.L. Collins. J. Chem. Phys., 1965, 42, 1072.
14. J.F. Duncan and R.M. Golding. Quart. Rev., 1965, 19, 36.
15. P.R. Brady, P.R.F. Wigley and J.F. Duncan. Rev. Pure and App. Chem., 1962, 12, 165.
16. T.C. Gibb, R. Greatrex and N.N. Greenwood. J.C.S.(A), 1968, 890.
17. R.H. Herber, W.R. Kingston and G.K. Wertheim. Inorg. Chem., 1963, 2, 153.

18. E. Fluck, W. Kerler and W. Neuwirth. *Angew. Chem. Int. Ed.*,  
1963, 2, 277.
19. H.M. Powell and R.V.G. Evans. *J.C.S.*, 1939, 206.
20. L.F. Dahl and R.E. Rundle. *J. Chem. Phys.*, 1957, 26, 1751.
21. L.F. Dahl and R.E. Rundle. *J. Chem. Phys.*, 1957, 27, 323.
22. N.E. Erickson and W. Fairhall. *Inorg. Chem.*, 1965, 4, 1320.
23. C.H. Wei and L.F. Dahl. *J.A.C.S.*, 1966, 88, 1821.
24. L.F. Dahl and J.F. Blount. *Inorg. Chem.*, 1965, 4, 1373.
25. R.L. Collins and R. Pettit. *J. Chem. Phys.*, 1963, 39, 3433.
26. R.H. Herber, R.B. King and G.K. Wertheim. *Inorg. Chem.*, 1964,  
3, 101.
27. L.E. Orgel. "An Introduction to Transition Metal Chemistry:  
Ligand Field Theory". Methuen, 1960.
28. T.C. Gibb, R. Greatrex, N.N. Greenwood and D.T. Thompson.  
*J.C.S.(A)*, 1967, 1663.
29. M. Thomas Jones. *Inorg. Chem.*, 1967, 6, 1249.
30. G.K. Wertheim and R.H. Herber. *J.A.C.S.*, 1962, 84, 2274.
- 31a. B. Dickens and W.N. Lipscomb. *J.A.C.S.*, 1961, 83, 4862.
- 31b. B. Dickens and W.N. Lipscomb. *J.A.C.S.*, 1961, 83, 489.
32. R.L. Collins and R. Pettit. *J.A.C.S.*, 1963, 85, 2332.
33. G.F. Emerson, J.E. Mahler, R. Pettit and R.L. Collins. *J.A.C.S.*,  
1964, 86, 3590.
34. R.B. King. *Inorg. Chem.*, 1963, 2, 807.

35. J.J. Spijkermann, F.C. Ruegg and J.R. DeVoe. "Applications of the Mossbauer Effect in Chemistry and Solid State Physics". International Atomic Energy Agency. Vienna, 1965, p.254.
36. T.C. Gibb. Ph.D. Thesis, University of Newcastle, 1966.
37. R.H. Herber and A. Hoffman. Unpub. data quoted in ref.7.p.35.
38. R.H. Herber. Unpub. data quoted in ref.7.p.35.
39. M.T. Jones. Inorg. Chem., 1967, 6, 1249.
40. F. Bonati and G. Wilkinson. J.C.S., 1964, 179.
41. N.N. Greenwood. "Mossbauer Effect in Organotin Compounds" in ref.35.
42. W. Hieber and F. Leutert. Z. Anorg. Allgem. Chem., 1932, 204, 145.
43. J.R. Case and M.C. Whiting. J.C.S., 1960, 4632.
44. H.W. Sternberg, R. Markby and I. Wender. J.A.C.S., 1957, 79, 6116.
45. W. Hieber and G. Brendel. Z. Anorg. Allgem. Chem., 1957, 289, 324.
46. H. Behrens and R. Weber. Z. Anorg. Allgem. Chem., 1955, 281, 190.
47. W. Hieber. Z. Anorg. Allgem. Chem., 1932, 204, 165.
48. R.B. King. "Adv. Organomet. Chem." Stone and West Eds. Academic Press, 1964, 2, 157.
49. H. Stammreich, K. Kawei, Y. Tavares, P. Krumholz, J. Behmoiras and S. Brill. J. Chem. Phys., 1960, 32, 1482.
50. R.B. King, S.L. Stafford, P.M. Treichel and F.G.A. Stone. J.A.C.S., 1961, 83, 3604.
51. W. Hieber and E. Fach. Z. Anorg. Allgem. Chem., 1938, 286, 95.
52. W. Hieber and N. Kahlen. Chem. Ber., 1958, 91, 2234.

53. W. Hieber and R. Werner. Chem. Ber., 1957, 90, 294.
54. W. Hieber, J. Sedlemeier and R. Werner. Chem. Ber., 1957, 90, 278.
55. W. Hieber and G. Brendal. Z. Anorg. Allgem., 1957, 289, 332.
56. E.W. Abel. Quart. Rev., 1963, 141.
57. W. Hieber and R. Werner. Chem. Ber., 1957, 90, 286.
58. W. Hieber and R. Werner. Z. Naturforsch., 1962, 17b, 211.
59. W.F. Edgell, M.T. Yang, B.J. Bulkin, R. Bayer and N. Koizumi.  
J.A.C.S., 1965, 87, 3080.
60. H. Stamreich, K. Kawai, Y. Tavares, P. Krumholz, J. Behmoiras  
and S. Brill. J. Chem. Phys., 1960, 32, 1482.
61. R. Greatrex. Personal Communication.
62. W.F. Edgell, J. Huff, J. Thomas, H. Lehman, C. Angell and G. Asato.  
J.A.C.S., 1960, 82, 1254.
63. S.J. LaPlaca and J.A. Ibers. J.A.C.S., 1963, 85, 3501 and Acta  
Cryst., 1965, 18, 511.
64. R. Eisenber and J.A. Ibers. Inorg. Chem., 1965, 4, 773.
65. S.J. LaPlaca, J.A. Ibers and W.C. Hamilton. J.A.C.S., 1964, 86,  
2288 and Inorg. Chem., 1964, 3, 149.
66. G. Bor. Inorg. Chim. Acta, 1967, 1, 81.
67. O.S. Mills, quoted by R.S. Nyholm "Tilden Lecture". Proc.  
Chem. Soc., 1961, 273.
68. G. Bor. Spectrochim. Acta, 1962, 18, 817.
69. C.C. Baraclough, J. Lewis and R.S. Nyholm. J.C.S., 1961, 2582.



70. M. Bigorgne and M. Pankowski. C.R. Acad. Sci. Paris, 1967,  
264, 1382.
71. U. Andes and G. Brendel. Z. Anorg. Allgem. Chem., 1957, 289, 324.
72. R.J. Doedens and L.F. Dahl. J.A.C.S., 1965, 87, 2576.
73. G.G. Sumner, H.P. Klug and L.E. Alexander. Acta. Cryst.,  
1964, 17, 732.
74. K. Noak. Spectrochim. Acta., 1963, 19, 1925.
75. G. Bor. Spectrochim. Acta., 1963, 19, 2065.
76. F. L'Eplattenier and F. Calderazzo. Inorg. Chem., 1967, 6, 2092.
77. A.P. Ginsberg. "Transition Metal Chemistry" R.L. Carlin Ed.  
1965, 1, 111.
78. Ref.77. p.214.
79. G.R. Dobson and R.K. Sheline. Inorg. Chem., 1963, 3, 1313 and  
refs. therein.
80. O.S. Mills et al., quoted in ref.56. p.155.
81. R.J. Doedens and L.F. Dahl. J.A.C.S., 1966, 88, 4847.
82. W. Hieber and A. Lipp. Chem. Ber., 1959, 92, 2075.
83. G.M. Sheldrick. Chem. Comm., 1967, 751.
84. M.J. Mays and R.N.F. Simpson. J.C.S.(A)., 1968, 1444.
85. For example E.O. Fischer and R. Aumann. J. Organometal. Chem.,  
1967, 8, Pl.

