

RESEARCH

Open Access



Efficiently sphere-decodable physical layer transmission schemes for wireless storage networks

Hsiao-feng (Francis) Lu¹, Amaro Barreal², David Karpuk² and Camilla Hollanti^{2*}

Abstract

Three transmission schemes over a new type of multiple-access channel (MAC) model with inter-source communication links are proposed and investigated in this paper. This new channel model is well motivated by, e.g., wireless distributed storage networks, where communication to repair a lost node takes place from helper nodes to a repairing node over a wireless channel. Since in many wireless networks nodes can come and go in an arbitrary manner, there must be an inherent capability of inter-node communication between every pair of nodes. Assuming that communication is possible between every pair of helper nodes, the newly proposed schemes are based on various smart time-sharing and relaying strategies. In other words, certain helper nodes will be regarded as relays, thereby converting the conventional uncooperative multiple-access channel to a multiple-access relay channel (MARC). The diversity-multiplexing gain tradeoff (DMT) of the system together with efficient sphere-decodability and low structural complexity in terms of the number of antennas required at each end is used as the main design objectives. While the optimal DMT for the new channel model is fully open, it is shown that the proposed schemes outperform the DMT of the simple time-sharing protocol and, in some cases, even the optimal uncooperative MAC DMT.

While using a wireless distributed storage network as a motivating example throughout the paper, the MAC transmission techniques proposed here are completely general and as such applicable to any MAC communication with inter-source communication links.

Keywords: Distributed communications, Distributed storage systems, Diversity-multiplexing gain tradeoff, MIMO, Multiple-access channel, Relay channel, Sphere decoding, Wireless networks

1 Introduction

The amount of data in cloud storage systems and worldwide data traffic have reached incredible numbers. It was estimated that in 2011, $1.8 \cdot 10^{21}$ bytes of data needed to be stored worldwide [1], a number that grew to an astonishing $4.4 \cdot 10^{21}$ bytes in 2013, and which is further expected to grow tenfold by 2020 [2]. The availability of such an astronomical amount of data and rapid progress in (wireless) communications engineering explain the observed growth of mobile data traffic, which increased by 69 % in 2014, reaching $2.5 \cdot 10^{18}$ bytes per month at the end of

the year. This amount of data traffic, which is expected to increase tenfold until 2019, corresponds to nearly 30 times the size of the entire internet in 2000. In addition, about 497 million mobile devices and connections were added globally in 2014, of which smart phones account for 88 %, so that—as foreseen—the number of mobile-connected devices exceeded the number of people on earth by the end of 2014 [3].

The massive amount of available data demands that data no longer be stored on a single device, but rather distributed among several storage nodes in a network, hence usually referred to as *distributed storage systems* (DSSs) (see [4] for a nice introduction). One of the main advantages of storing information in a distributed manner is that the storage system can be made robust against failures by introducing some level of redundancy. Some examples of

*Correspondence: camilla.hollanti@aalto.fi

²Department of Mathematics and Systems Analysis, Aalto University, P.O. Box 11100, FI-00076 AALTO (Espoo), Finland

Full list of author information is available at the end of the article

real-life distributed storage systems are Apache Cassandra [5], which is a DSS initially developed at Facebook, and Windows Azure [6], created by Microsoft.

More formally, a DSS consists of n storage nodes over which a file is stored in a redundant manner by dividing it into fragments and distributing the fragments among n nodes using, for instance, a (n, k) maximum distance separable (MDS) erasure code [7]. MDS codes satisfy the Singleton bound and have the convenient property of being able to reconstruct the file by contacting any k of the nodes. Another key feature of a DSS is the ability to repair, meaning that when a node fails (that is a device breaks down or leaves the network), the failed node can be repaired or replaced. If an (n, k) storage code further satisfies the condition that any failed node can be repaired or replaced by contacting any K of the remaining nodes, termed *helpers*, the code is called an (n, k, K) storage code, and the node replacing the failed one is called a *repairing node*, or a *newcomer* [8], if it is not one of the already existing nodes in the network.

Sophisticated storage protocols have been developed, always giving a tradeoff between the amount of data that needs to be stored in any of the storage nodes, and the amount of data that needs to be retrieved for repairing a lost node, also called repair bandwidth (see e.g. [8, 9] for details), and codes lying on the storage-repair bandwidth tradeoff curve [8, 10] are called *regenerating codes*. Explicit, tradeoff achieving regenerating codes can be found in the literature, see [9, 11], among others.

One important aspect of future DSSs lies in the ability to communicate over wireless channels, making it possible to store or retrieve a file using a wireless connection, even if the storage cloud itself might be wired. This is a feature related to the more general concept of *wireless edge* [12–15]. The mobility of a user has become crucial in everyday life, and wireless channels are used for data transmission for increased flexibility. However, it is well-known that communicating over a fading channel in a wireless DSS [16, 17] makes repair transmissions prone to physical layer errors.

Consider the wireless repair transmission of a DSS, that is, the case of repairing a failed/lost node and replacing it with a repairing node by contacting any K of remaining storage (helper) nodes via wireless links. We assume that both types of nodes may be equipped with multiple antennas. Then, the transmission from the K helpers to the repairing node can be regarded as wireless multiple-input multiple-output (MIMO) multiple-access communication [18–20] with an additional feature of inter-helper communication among the K helpers. To see this, note that the MIMO multiple-access channel (MAC) studied in classical information theory [21] assumes only the existence of communication links from the helpers to the repairing node, or equivalently from sources to destination. Yet

in many wireless distributed storage networks¹, there are often more nodes present and connected than those storing data, i.e., there are *blank nodes* in addition to the actual storage nodes. The total number of nodes can be dynamic even though the number of storage nodes would be fixed, see Fig. 1 for illustration. Now, the loss of a node can happen to any of the n storage nodes, and the K helpers can be any subset of the remaining storage nodes. The role of a repairing node can be taken by any of the blank nodes (also a new node entering the system will be blank in the beginning). This implies that an inherent communication link exists between the blank nodes and the storage nodes. After repair, a node that was previously blank becomes a storage node, and after this can assume the role of a helper node. Storage nodes may also erase their stored data and become blank, after which they can also assume the role of a repairing node, etc. This means that an inter-node communication capability actually exists between every pair of helper nodes, therefore calling for the design of efficient transmission schemes when the sources are further allowed to communicate with each other in a wireless MIMO-MAC.

Yet another example to motivate such inter-helper links is as follows. Notice that each of the n wireless storage nodes in the network consists of a wireless component and a memory component. In case of the wireless component of a node failing, we simply replace it with a new wireless component, and there is no need to contact the helpers to reconstruct the data. On the other hand, if the memory component fails, the “repair” of the node (hence the name of repairing node) happens by repairing the memory component of the node with the aid of helper nodes. That is, the node is not replaced by a completely new node. In this sense, the failed node is still one of the original n storage nodes, and the repairing process is done by contacting any K of the remaining nodes. In other words, the failed node and the repairing node are the same node with the same wireless component. This justifies the requirement that the inter-helper link must exist between every pair of nodes.

When communicating over a wireless channel between terminals equipped with multiple antennas, *space-time codes* [22–26] are often employed to protect the transmitted information from adverse channel effects such as fading and noise. The asymptotic error-performance of space-time codes is commonly dictated by the diversity-multiplexing gain tradeoff (DMT) [27]. Assume each of the K helper nodes has n_t transmit antennas and transmits simultaneously at the same rate of $R = r \log_2 \text{SNR}$ in bits per channel use to the repairing node with n_r receive antennas, where SNR is the signal-to-noise power ratio, and r is commonly referred to as the *multiplexing gain* [27]. The optimal MIMO-MAC DMT was given by Tse et al. in [28] and characterizes the maximal diversity gain,

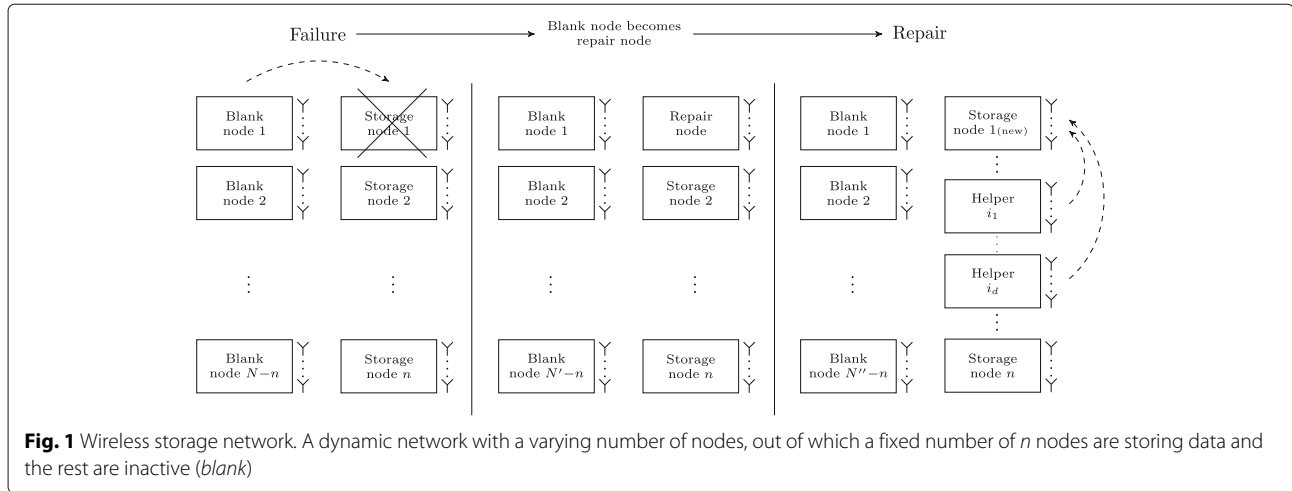

or equivalently the smallest error probability, that can possibly be achieved by any space-time code. A general construction of MIMO-MAC DMT optimal space-time codes was proposed in [26] for any triple (n_t, n_r, K) and multiplexing gain r . These MIMO-MAC codes are constructed from cyclic division algebras [23, 29] and have a linear-dispersion form [30]. Therefore, they can be decoded in the maximal-likelihood (ML) sense by a sphere decoder [31]. While sphere decoding is known to be an efficient implementation of ML decoding, it is unfortunate that when $Kn_t > n_r$, decoding these DMT-optimal codes requires at least partial brute-force decoding before the sphere decoder begins to function [32], or alternatively one has to allow for suboptimal decoding methods, incurring degraded performance [33]. The former approach, though achieving the optimal performance, results in an exponential increase of decoding complexity when Kn_t becomes large and n_t remains fixed [32].

Motivated by these realistic problems in wireless DSSs, new transmission schemes based on various strategies are proposed in this paper. The DMT, together with efficient sphere-decodability and low transmitter and receiver structural complexity in terms of the number of antennas required at each end, are used as the main design objectives, thus naturally establishing a DMT-complexity tradeoff.

1.1 Contributions and related work

In most of the storage and network-coding related research the focus is on the (logical) network layer, while the physical layer functionality is usually ignored or assumed perfect. An exception is [16], where a so-called partial downloading scheme is proposed, which allows for data reconstruction with limited bandwidth by downloading only parts of the content of helper nodes. This is relevant in the fading channel scenario, and the idea can potentially be combined with the present work. In

[17], optimal storage codes are constructed for the error-and-erasure scenario, but fading is not addressed. Isolated from the storage point of view, a lot of research has been carried out in physical layer wireless communications, see e.g. [34] and the references therein.

Remark 1. *An obvious, but naive attempt would be to try to simply combine an optimal storage code on the network layer and an optimal space-time code on the physical layer. The reason for avoiding this approach is both its structural (many antennas) and computational (decoding subject to partial brute-force) complexity.*

In this paper², we propose a class of transmission schemes for MIMO-MAC when communication links among the sources (helper nodes) do exist, which is generally true in many wireless storage networks. The proposed schemes allow for the design of efficiently sphere-decodable space-time codes³ with only one or two receive antennas. This is in contrast to the state-of-the-art MIMO-MAC codes [26] that have extremely good performance but require Kn_t receive antennas at the repairing node to enable efficient sphere decoding. This is of course unacceptable even for a relatively small value of K , since wireless networks are often heterogenous and might include nodes with only few or even just one antenna. At the moment, to the best of the authors' knowledge, no such scheme exists for large value of K when the receiver has only 1 or 2 antennas, except for the trivial scheme of time-sharing among K helper nodes.

This paper is organized as follows. In Section 2, we will present the channel model for DSS repair transmission, which can be seen as a MIMO-MAC in the presence of communication links among helper nodes. A brief introduction on DMT will also be given therein. Section 2.2 briefly reviews the notion of complexity exponent, which was established by Jaldén and Elia [35] for measuring

the minimal computational complexity required by sphere decoders in order to achieve a certain diversity performance. The complexity exponent of existing MIMO-MAC DMT optimal codes [26, 32, 36] is also given to further motivate our design objectives that are presented in Section 3 and to serve as a baseline for comparing the complexity of the first proposed scheme given in Section 4. The first scheme is based on a simple time sharing among *pairs of helpers*, when $n_t = 1$, $n_r = 2$ and $K \geq 2$. The resulting DMT falls between the simple time sharing DMT and optimal MIMO-MAC DMT [28].

We then present two more elaborate schemes extending the first one, achieving a higher DMT by taking advantage of the inter-helper communication links and transforming the overall DSS network into a series of relay networks, where conventional half-duplex⁴ cooperative-communication protocols such as the non-orthogonal amplify-and-forward (NAF) strategy [37, 38] will be used. In particular, it will be seen that these schemes can outperform the MIMO-MAC DMT at certain multiplexing gains, simply due to the use of inter-helper communications in the DSS. Moreover, our results on the DMTs for NAF-based relay networks not only improve, but also extend the ones presented in related works, such as [39, 40].

2 Transmission model and preliminaries

Consider a wireless DSS with K helper nodes, equipped with n_t transmit antennas each, and a repairing node with n_r receive antennas. Let $H_i \in \mathbb{C}^{n_r \times n_t}$ be the channel matrix, and $X_i \in \mathbb{C}^{n_t \times T}$ the code matrix associated with the i th helper node, where T is the number of channel uses needed for transmitting X_i . The received signal matrix at the repairing node is given by

$$Y = \sum_{i=1}^K H_i X_i + W, \tag{1}$$

where $W \in \mathbb{C}^{n_r \times T}$ is a matrix modeling complex additive white Gaussian noise (AWGN). The entries of H_i and W_i are independent and identically distributed (i.i.d.) circularly symmetric complex Gaussian random variables with zero mean and unit variance, a distribution which we henceforth denote as $\mathcal{CN}(0, 1)$. The code matrices X_i are required to satisfy the average power constraint $\mathbb{E}\|X_i\|^2 \leq T \cdot \text{SNR}$. It is also assumed throughout the paper that the repairing node has a complete knowledge of channel state information $\{H_i : i = 1, \dots, K\}$.

Due to the nature of the DSS, the helper nodes can communicate with each other, a feature not seen in classical MIMO-MAC. Focusing on the i th helper node, let $G_{i,j} \in \mathbb{C}^{n_t \times n_t}$ be the channel matrix and $S_j \in \mathbb{C}^{n_t \times T}$ be the

code matrix sent by the j th helper node, $j \neq i$; then, the signal matrix received at the i th helper node is given by

$$Y_i = \sum_{\substack{j=1 \\ j \neq i}}^K G_{i,j} S_j + Z_i, \tag{2}$$

where the entries of $G_{i,j}$ and Z_i are again modeled as i.i.d. $\mathcal{CN}(0, 1)$ random variables, and the signal matrices S_j satisfy $\mathbb{E}\|S_j\|^2 \leq T' \cdot \text{SNR}$. A complete knowledge of $\{G_{i,j}\}$ is assumed to be available at the i th node. Finally, it is assumed throughout the paper that all communication links are half-duplex. A pictorial description of the above channel model is given in Fig. 2.

2.1 The DMT

One of the design objectives in this paper is to provide high performance transmission schemes for wireless DSS repair transmissions. The performance of each scheme will be measured by the DMT [27, 34]. In order to simplify the discussion of DMT, let us ignore the existence of the inter-helper channels for the moment and focus only on the channel input-output relation (1), where only the direct channels from the K helper nodes to the repairing node are of concern. Assuming each helper node transmits at the same multiplexing gain r to the repairing node, we say a scheme achieves diversity gain $d(r)$ if its outage probability $P_{\text{out}}(r)$, which is defined as the probability of mutual information $I(X_{i_1}, \dots, X_{i_s}; Y | H_1, \dots, H_K)$ being strictly less than $s \cdot r \log_2 \text{SNR}$ for some $\{i_1, \dots, i_s\} \subseteq \{1, \dots, K\}$, satisfies

$$-\lim_{\text{SNR} \rightarrow \infty} \frac{\log P_{\text{out}}(r)}{\log \text{SNR}} = d(r), \tag{3}$$

and we will write the above as

$$P_{\text{out}}(r) \doteq \text{SNR}^{-d(r)}. \tag{4}$$

The outage probability $P_{\text{out}}(r)$ is an asymptotic lower bound on the error probability of the scheme [27, 34]

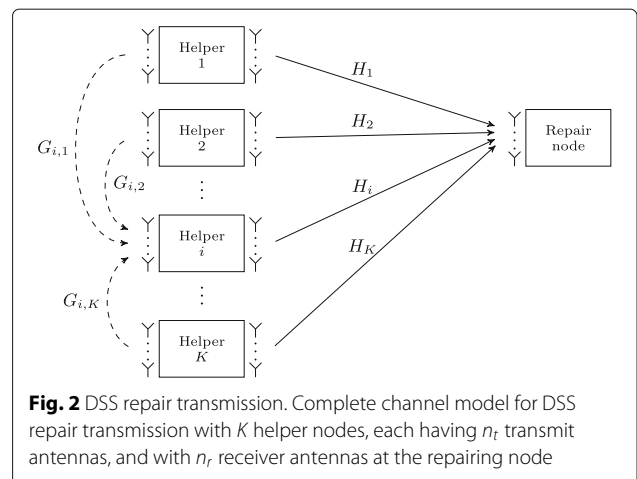

when SNR is large and the multiplexing gain r remains fixed.

For objectivity, we will compare the performance of the proposed schemes with the following optimal DMT [28] for MIMO-MAC⁵

$$d_{n_t, n_r, K}^*(r) = \min \{d_{n_t, n_r}^*(r), d_{Kn_t, n_r}^*(Kr)\}, \quad (5)$$

where $d_{m, n}^*(r)$ is the optimal DMT for an $(n_t \times n_r)$ point-to-point MIMO channel and is given by the piecewise linear function connecting the points $(r, (n_t - r)(n_r - r))$ for $r = 0, 1, \dots, \min\{n_t, n_r\}$ [27]. We must emphasize that (5) is known to be optimal for the non-cooperative MIMO-MAC, that is, the case when the K helper nodes share no common information, meaning that the inter-helper channels (2) do not exist, and the file fragments stored at the K helper nodes are all statistically independent⁶. Therefore, with a properly designed scheme, it is expected that a higher DMT performance than (5) can be achieved in DSS repair transmission.

2.2 Sphere decoding complexity of state-of-the-art MIMO-MAC codes

A general construction of MIMO-MAC space-time codes was proposed in [26] and was shown to achieve the optimal DMT (5) for any triple (n_t, n_r, K) and multiplexing gain r . More specifically, given n_t and K , the component code C_i of the i th helper node is taken from an algebraic lattice of lattice rank⁷ $2n_t K_o^2$ in [26], and C_i consists of $(n_t \times T)$ matrices with $|C_i| \doteq \text{SNR}^{rT}$ and $T = n_t K_o$, where K_o is the smallest odd integer $\geq K$.

To estimate the complexity of decoding the overall code $C_1 \times \dots \times C_K$ using a joint sphere decoder, we follow [35] by using the notion of *complexity exponent* as a complexity measure.

Definition 1 (Complexity exponent [35]). *Given the multiplexing gain r , let $C_{r, k}$ be a lattice code consisting of $(n_t \times T)$ codeword matrices with $|C_{r, k}| \doteq \text{SNR}^{rT}$, $k = 1, \dots, K$. Let \mathcal{D}_r be a decoder for the overall code $C_r = C_{r, 1} \times \dots \times C_{r, K}$, subject to a computational constraint $N_{\max}(r)$, in floating point operations (flops) per T channel uses, in the sense that after $N_{\max}(r)$ flops, the decoder \mathcal{D}_r must simply terminate, potentially prematurely and before completing the task, thus declaring an error. We then say \mathcal{D}_r achieves diversity order $d(r)$ with complexity exponent $c(r)$ if \mathcal{D}_r achieves error probability $P_e \doteq \text{SNR}^{-d(r)}$ using at most $N_{\max}(r) \doteq \text{SNR}^{c(r)}$ (cf. (3),(4)) flops of computational reserves. \square*

The above definition means that in order to decode the code C_r using a joint sphere decoder, one does not have to decode every received signal matrix, especially when the communication channel is deeply faded. Instead, one can enforce a complexity constraint (also called a *halting*

policy) at the sphere decoder, say at most $N_{\max}(r)$ flops of computational reserves. By choosing $N_{\max}(r)$ large enough such that the probability of any premature termination of the sphere decoder is asymptotically no larger than $\text{SNR}^{-d_{n_t, n_r, K}^*(r)}$, the overall error probability at most $2 \cdot \text{SNR}^{-d_{n_t, n_r, K}^*(r)}$, thereby achieving the same diversity $d_{n_t, n_r, K}^*(r)$.

It was shown in [32, 36] that the complexity exponent for decoding the DMT optimal code [26] is given by

$$c_{n_t, n_r, K}(r) = K_o r (Kn_t - n_r) \cdot \mathbf{1}(Kn_t > n_r) + \sup_{\underline{\mu} \in \mathcal{B}(r)} K_o n_t \sum_{i=1}^{\nu} \left(\frac{r}{n_t} - (1 - \mu_i)^+ \right)^+, \quad (6)$$

where $\mathbf{1}(\cdot)$ is the usual indicator function, $\nu = \min\{Kn_t, n_r\}$, $(x)^+ := \max\{x, 0\}$ and

$$\mathcal{B}(r) = \left\{ \underline{\mu} = [\mu_1 \dots \mu_\nu]^\top \in \mathbb{R}^\nu : \mu_1 \geq \dots \geq \mu_\nu \geq 0, \sum_{i=1}^{\nu} (|Kn_t - n_r| + 2i - 1) \mu_i \leq d_{n_t, n_r, K}^*(r) \right\}. \quad (7)$$

There is an intuitive explanation for the term $K_o r (Kn_t - n_r)$ in (6) when $Kn_t > n_r$. Recall that the component code C_i is taken from a certain subset of an algebraic lattice Λ_i of rank $2n_t^2 K_o$. This means that each codeword matrix X_i of C_i is of the form $X_i = \sum_{\ell=1}^{n_t^2 K_o} x_{i, \ell} C_{i, \ell}$, where $\{C_{i, \ell} : \ell = 1, \dots, n_t^2 K_o\}$ is a basis for Λ_i , and the $x_{i, \ell}$ are independent QAM symbols taken from a certain set $\mathcal{A} \subset \mathbb{Z}[\iota]$ of size $\text{SNR}^{\frac{r}{n_t}}$, $\iota = \sqrt{-1}$. Thus, we can rewrite (1) as

$$Y = \sum_{i=1}^K \sum_{\ell=1}^{n_t^2 K_o} H_i C_{i, \ell} x_{i, \ell} + W, \quad (8)$$

or equivalently in a vector form

$$\underline{y} = H \underline{x} + \underline{w}, \quad (9)$$

where $\underline{x} = [x_{1, 1}, \dots, x_{1, n_t^2 K_o}, \dots, x_{K, n_t^2 K_o}]^\top$, \underline{y} is the vectorization of the matrix Y , and H is the corresponding matrix of size $(n_r K_o n_t \times K n_t^2 K_o)$ by (8). When decoding (9) using a sphere decoder, one first performs a QR-decomposition of the matrix H , say $H = QR$. If $Kn_t > n_r$, the matrix R is no longer upper triangular; it is a trapezoidal matrix with

$$Kn_t^2 K_o - n_r K_o n_t + 1 = K_o n_t (Kn_t - n_r) + 1$$

nonzero entries in the bottom row. Hence, any sphere decoder for (9) must first resolve – perhaps by brute-force – the $|\mathcal{A}|^{K_o n_t (Kn_t - n_r)} = \text{SNR}^{K_o r (Kn_t - n_r)}$ ambiguities before processing the root of the sphere decoding tree. The number of ambiguities then forms the first term in (6).

Remark 2. *A different definition of complexity exponent has appeared in [41], where Damen et al. studied the*

number of flops required by a sphere decoder to decode a fixed-rate space-time code at various finite SNR values. In particular, they defined the complexity exponent as the logarithm to base m of the number of flops required by a sphere decoder to complete its task, where m is the length of vector \underline{x} defined in (9). Below we highlight some of the major differences between Damens' definition of complexity exponent and the one considered in this paper (cf. Definition 1).

- Damens' definition focuses on a code with a fixed rate, and Definition 1 concerns more with the theoretical asymptote at high SNR regime when the rate scales linearly with \log_2 SNR.
- Definition 1 considers the possibility of having a halting policy, while Damens' definition requires the sphere decoder to complete its task at all channel realizations.

Remark 3. In [42] Damen et al. proposed to decode (9) by using GDFE-MMSE preprocessing followed by the sphere decoder when $Kn_t > n_r$, in hope of making the matrix R upper-triangular and avoiding the need of resolving the ambiguities. However, it can be seen from [32, 36] that at high SNR regime the matrix R – after MMSE-GDFE preprocessing – is ill-conditioned with $K_0 n_t (Kn_t - n_r)$ number of singular values arbitrarily close to zero. This also explains the appearance of the first term in (6).

On the other hand, when the code has a fixed rate and operates in the low or moderate SNR regime, the MMSE-GDFE approach does offer a certain complexity reduction with a negligible performance loss, as the singular values of R are numerically well-behaved in general. Other approaches for further complexity reductions under such premises are also available in the literature. For instance, Barbero and Thompson [43] proposed a fixed-complexity sphere decoder, where the number of candidates to be searched at the i -th level of sphere decoding tree is at most n_i , thereby yielding a constant complexity $\prod_i n_i$. Another way to reduce complexity is through the various orderings of singular values of R . A comprehensive study in this direction can be found for example in [44]. We shall emphasize that the complexity exponents simulated in [43, 44] are both based on Damens' definition [41] (cf. Remark 2) because of the aforementioned premises.

In Fig. 3, we plot the complexity exponents for the sphere decoding of MAC DMT optimal codes \mathcal{C}_r [26] when $n_t = 2$, $K = 5$, and $n_r = 2, 10, 100$, respectively. It can be seen that these codes can be efficiently decoded by sphere decoders only when $n_r \gg Kn_t$. Such a requirement is often impossible in practice, particularly in heterogeneous storage networks, where nodes may have only a small number of antennas in use.

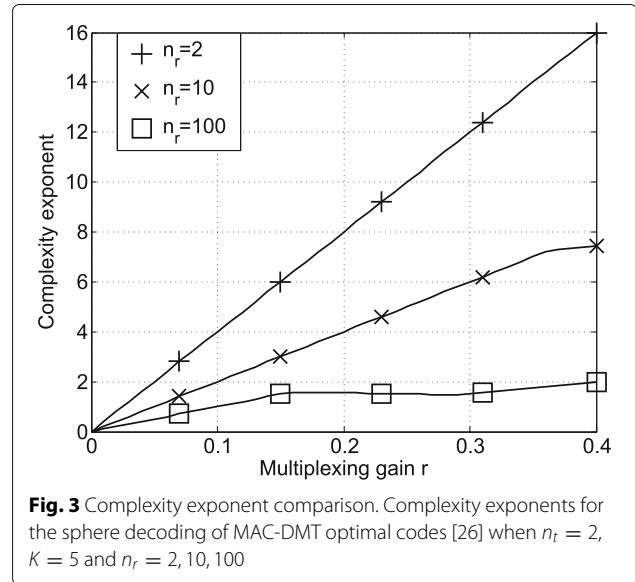

Remark 4. In case of $n_r \geq Kn_t$, it has been shown [45, 46] that the DMT optimal MIMO-MAC lattice codes can be decoded with sub-exponential complexity, i.e., having a complexity exponent asymptotically equal to 0, using the Lenstra-Lenstra-Lovász-based lattice reduction aided regularized lattice decoder. The decoder is a combination of GDFE-MMSE, lattice reduction and sphere decoding, and it has a vanishing gap of performance loss to the exact ML decoding as SNR approaches infinity.

3 Objectives for the design of transmission schemes

In Section 2, we have seen that there is a fundamental difference between the channel for DSS repair transmission and the classical MIMO-MAC, in the sense that the former includes additional inter-helper communication links. Thus, the MIMO-MAC DMT (5) and the MIMO-MAC codes [26] are no longer optimal in scenarios such as DSS repair transmission. Moreover, due to these additional inter-helper channels, it is expected that the DSS repair transmission can have a higher optimal DMT than (5). This then calls for the design of new transmission schemes with good DMT performance for DSS repairing, which is the first design objective considered in this paper.

The second design objective comes from the observation of high decoding complexity of MIMO-MAC codes [26] in Fig. 3 when $Kn_t > n_r$. In a DSS, it is often possible that K is large, and n_r is relatively small and fixed. This then calls for the design of new transmission schemes that can yield efficiently sphere-decodable space-time codes avoiding the need to process the ambiguities by brute-force. Potentially, such an aim could be achieved by reducing the number of “active” helper nodes, i.e., reducing the effective value of K in (1), such that the average

number of independent QAM symbols received by the repairing node at each channel use be no larger than n_r , as observed from (6).

In the subsequent sections, we will focus on the case of $n_t = 1$ and $K \gg n_r$, and we will provide three transmission schemes, each for a different configuration of the wireless DSS network and for a different design objective. The first scheme is given in Section 4 for the case of two receive antennas and an arbitrary number of helper nodes, each having one transmit antenna. It is based on a simple time sharing among pairs of helpers and is aimed at having a low sphere-decoding complexity at a cost of certain DMT performance-loss due to its neglect of existing inter-helper links. The DMT for this scheme falls between the simple time sharing DMT and optimal MIMO-MAC DMT (5).

Two more elaborate schemes will be presented in Sections 5 and 6, respectively, where we aim to improve the DMT performance at the possible cost⁸ of higher decoding complexity. These schemes take advantage of inter-helper channels and transform the overall DSS network into a series of relay networks, where the conventional half-duplex NAF protocol [37, 38] will be used. In particular, we will see that these schemes can outperform the MIMO-MAC DMT (5) at certain multiplexing gains, simply by exploiting inter-helper communications in the DSS.

4 Scheme 1: $n_t = 1$, $n_r = 2$, and K helper nodes

We have seen in Section 2.2 that the existing state-of-the-art MIMO-MAC space-time codes [26] could incur an extremely high decoding complexity when the repairing node has only a few number of antennas. Thus, our major aim in this section is to provide a new transmission scheme that can yield space-time codes with reduced decoding complexity. In particular, we would like these potential codes to be efficiently sphere-decodable, by which we mean that the H matrix, when writing the channel input-output relation in a vector form (cf. (9)), has linearly independent columns with probability one.

Besides the desired property of being efficiently sphere-decodable, the complexity of the transmission schemes should also be considered. In other words, if we ignore the existence of inter-helper links (2), then the schemes for DSS repair transmission can be made relatively simple. These are the main objectives of Scheme 1.

Let $\mathcal{K} = \{1, 2, \dots, K\}$ denote the set of K helper nodes, and let \mathcal{U} be a collection of two subsets of \mathcal{K} , defined as below

$$\mathcal{U} := \begin{cases} \{\{1, 2\}, \{3, 4\}, \dots, \{K-1, K\}\}, & \text{if } K \text{ even,} \\ \{\{1, 2\}, \dots, \{K-2, K-1\}, \{K, 1\}, \{2, 3\}, \dots, \{K-1, K\}\}, & \text{if } K \text{ odd.} \end{cases}$$

With the above, the proposed scheme is the following. For each $U = \{u_1, u_2\} \in \mathcal{U}$, only helper nodes u_1 and

u_2 are allowed to transmit during the active period of U . This implies that the probability of helper node k transmitting equals $\frac{2}{K}$ for every $k \in \mathcal{K}$. In order to achieve an average multiplexing gain r , each helper node k , when chosen according to U , i.e. $k \in U$, should actually transmit at a higher multiplexing gain $\frac{Kr}{2}$. We summarize the above scheme below, and a pictorial description of Scheme 1 is given in Fig. 4.

Scheme 1

- 1: **for** each $U = \{u_1, u_2\} \in \mathcal{U}$ **do**
- 2: Helper-nodes u_1 and u_2 transmit using the MIMO-MAC code given in [26, Eq. (20)] for $n_t = 1$, two users and multiplexing gain $\frac{Kr}{2}$.
- 3: **end for**

The following theorem is a straightforward consequence of [34].

Theorem 1. *The DMT performance achieved by Scheme 1 is*

$$d_1(r) = \min \left\{ d_{1,2}^* \left(\frac{Kr}{2} \right), d_{2,2}^* (Kr) \right\} \quad (10)$$

In Fig. 5, we consider the case $n_t = 1$, $n_r = 2$ and $K = 10$, and compare $d_1(r)$ to $d_{1,2,10}^*(r)$, which is the DMT corresponding to all 10 helper nodes transmitting simultaneously. The function $d_0(r)$ is the DMT for the time-division multiple-access (TDMA)-based scheme, by which we mean that each helper node takes turns in an orthogonal manner to transmit information to the repairing node at multiplexing gain Kr . It can be seen that the first proposed scheme outperforms the TDMA scheme in terms of the DMT, and there is a considerable gap between $d_1(r)$ and $d_{1,2,10}^*(r)$. However, the comparison is unfair in the sense that in order to achieve $d_{1,2,10}^*(r)$ the codes in [26] would require exponentially large computational reserves, or equivalently an exponentially long time, for decoding.

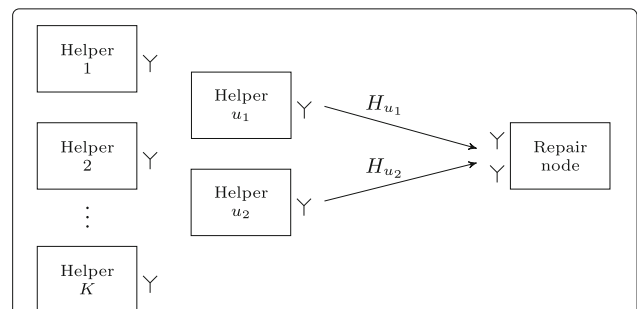
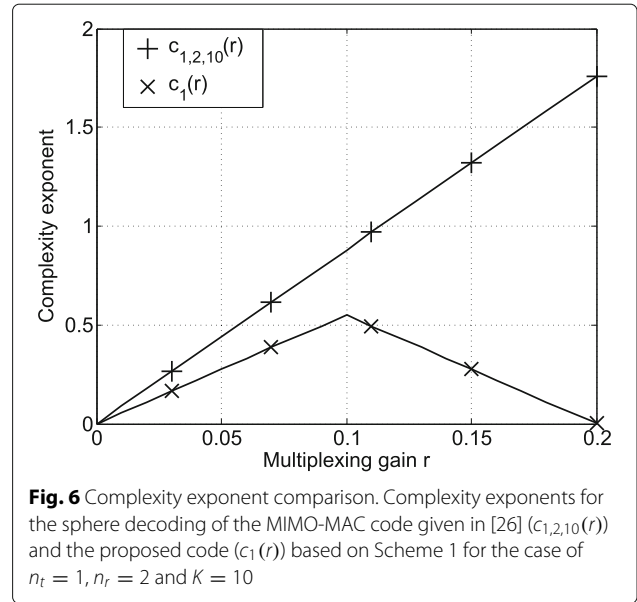
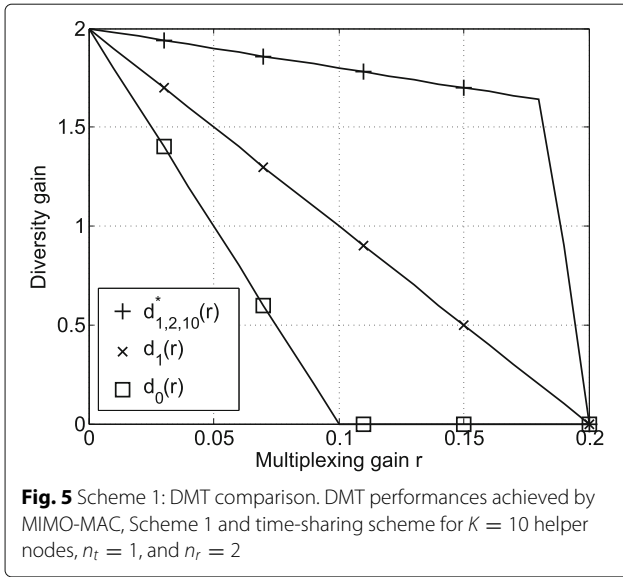

Fig. 4 Channel model of Scheme 1. Channel model for Scheme 1 at the U th step, $U = \{u_1, u_2\} \subset \{1, 2, \dots, K\}$



Continuing the example of $n_t = 1$, $n_r = 2$ and $K = 10$, by modifying the two-user MIMO-MAC code given in [26] according to Scheme 1, it can be directly seen from (6) that the resulting code achieves DMT $d_1(r)$ with complexity exponent

$$c_1(r) := 3 \sup_{\underline{\mu} \in \mathcal{B}_1(r)} \sum_{i=1}^2 \left[\min \left\{ \frac{rK}{2}, \frac{Kr}{2} + \mu_i - 1 \right\} \right]^+, \quad (11)$$

where

$$\mathcal{B}_1(r) = \left\{ \underline{\mu} = [\mu_1 \ \mu_2]^\top \in \mathbb{R}^2 : \mu_1 \geq \mu_2 \geq 0, \mu_1 + 3\mu_2 \leq d_1(r) \right\}, \quad (12)$$

when it is decoded using a sphere decoder with halting policies. In Fig. 6, we compare $c_1(r)$ to the complexity exponent $c_{1,2,10}(r)$ of the MIMO-MAC code given in [26] for the case $n_t = 1$, $n_r = 2$ and $K = 10$. It can be clearly seen that the proposed scheme can yield a code with with a much lower decoding complexity.

5 Scheme 2: $n_t = 1$, general n_r , and K helper nodes

The aim of Scheme 1 presented in the previous section was to have a small decoding complexity, at a cost of certain DMT performance loss due to the neglect of inter-helper links in DSS repair-communication. In this section as well as the next, we will shift our focus to designing transmission schemes that take into account these inter-helper links and beat the DMT performance $d_{n_t, n_r, K}^*(r)$.

Consider a DSS repair channel with K helpers, each having $n_t = 1$ transmit antenna, and a repairing node with n_r receive antennas. To make good use of the inter-helper links, we interpret in Scheme 2 some of the links as links

of a relay channel. More specifically, in this scheme each of the K helper nodes will take turns acting as the source in a cooperative relay network [37], while the remaining $K - 1$ helper nodes play the role of relays helping the source to send information to the repairing node.

With the above, the proposed scheme is a modification of the NAF protocol [37, 38] for a cooperative relay network with $K - 1$ relays. It consists of K phases, and each phase requires at least $2(K - 1)$ channel uses. Thus, the total number of channel uses required by Scheme 2 is at least $2K(K - 1)$.

Let $\mathcal{K} = \{1, 2, \dots, K\}$ denote the set of K helper nodes. Given $k \in \mathcal{K}$, the scheme is at the k th phase, and helper node k acts as the source of a relay network. The remaining helper nodes $\mathcal{R}_k := \mathcal{K} \setminus \{k\} = \{u_1, \dots, u_{K-1}\}$ are the relays. At the t th channel use of the k th phase, $t = 1, 2, \dots, 2(K - 1)$, node k broadcasts a signal $x_{k,t}$, subject to the power constraint $\mathbb{E}|x_{k,t}|^2 \leq \text{SNR}$, to all nodes in \mathcal{R}_k as well as to the repairing node. Due to the half-duplex assumption in Section 2, the nodes in \mathcal{R}_k can either receive or transmit, but not both at the same time. Therefore, the behavior of each node $u_i \in \mathcal{R}_k$ is set such that it receives the signal from node k when $t = 2i - 1$ and transmits to the repairing node when $t = 2i$. More specifically, the signal received by node u_i at $t = 2i - 1$ is given by

$$r_{u_i, 2i-1} = g_{u_i, k} x_{k, 2i-1} + z_{u_i, k, 2i-1}, \quad (13)$$

where $g_{u_i, k}$ and $z_{u_i, k, 2i-1}$ are i.i.d. $\mathcal{CN}(0, 1)$ random variables representing the channel gain from node k to node u_i and the additive noise, respectively, as defined in (2). Node

u_i then amplifies the signal $r_{u_i,2i-1}$ with an amplification factor $a_{u_i,k}$ set such that

$$\mathbb{E}|a_{u_i,k}r_{u_i,2i-1}|^2 \leq \text{SNR}, \quad (14)$$

where the expectation is taken with respect to $x_{k,2i-1}$ and $z_{u_i,k,2i-1}$, since $g_{u_i,k}$ is already known to node u_i . Equivalently, we have

$$|a_{u_i,k}|^2 \leq \frac{\text{SNR}}{1 + \text{SNR}|g_{u_i,k}|^2}. \quad (15)$$

Then, at channel use $t = 2i$, node u_i joins node k and sends the amplified signal $a_{u_i,k}r_{u_i,2i-1}$ to the repairing node.

Since each helper node k is allowed to transmit its own message to the repairing node during the k th phase, its multiplexing gain must be increased to $K \cdot r$ in order to achieve the desired average multiplexing gain r . We now summarize the steps of Scheme 2 below. A pictorial description of Scheme 2 is given in Fig. 7.

Scheme 2

- 1: **for** each $k = 1, 2, \dots, K$ **do**
- 2: Set $\mathcal{K} \setminus \{k\} = \{u_1, \dots, u_{K-1}\}$
- 3: **for** $i = 1, 2, \dots, (K - 1)$ **do**
- 4: Node k broadcasts a signal $x_{k,2i-1}$ at multiplexing gain Kr to all nodes at channel use $t = 2i - 1$. The signals received by node u_i and the repairing node are respectively given by

$$r_{u_i,2i-1} = g_{u_i,k}x_{k,2i-1} + z_{u_i,k,2i-1}, \quad (16)$$

$$\underline{y}_{k,2i-1} = \underline{h}_k x_{k,2i-1} + \underline{w}_{k,2i-1}. \quad (17)$$

- 5: Node k broadcasts a signal $x_{k,2i}$ to all nodes at channel use $t = 2i$, and node u_i simultaneously sends $a_{u_i,k}r_{u_i,2i-1}$. The signal received by the repairing node when $t = 2i$ is

$$\underline{y}_{k,2i} = \underline{h}_k x_{k,2i} + \underline{h}_{u_i} a_{u_i,k} r_{u_i,2i-1} + \underline{w}_{k,2i}. \quad (18)$$

- 6: **end for**
- 7: **end for**

5.1 DMT achieved by Scheme 2

Note firstly that by the symmetry among the phases of Scheme 2, it suffices to analyze the DMT achieved within the first phase, i.e., for $k = 1$, where the helper node 1 acts as the source, and the remaining helper nodes are relays. Thus, for notational convenience, we will henceforth drop the subindex k .

Set $N = 2(K - 1)$, and let x_t be a $\mathbb{C}\mathcal{N}(0, \text{SNR})$ random variable, representing the signal sent by helper node 1 at time instance t for $t = 1, 2, \dots, N$. Then, the signal received by the repairing node at the t th channel use is

$$\underline{y}_t = \begin{cases} \underline{h}_1 x_t + \underline{w}_t, & t \text{ odd,} \\ \underline{h}_1 x_t + a_i \underline{h}_i (g_i x_{t-1} + z_i) + \underline{w}_t, & t \text{ even and } i = \frac{t}{2} + 1, \end{cases} \quad (19)$$

where g_i and z_i 's are i.i.d. $\mathbb{C}\mathcal{N}(0, 1)$ random variables obtained by re-indexing the corresponding variables in (16) for notational convenience. The amplification factor $a_i \in \mathbb{R}^+$, $i = 2, \dots, K$, is set such that

$$|a_i|^2 \leq \frac{\text{SNR}}{1 + \text{SNR}|g_i|^2}.$$

We can equivalently reformulate the received vectors \underline{y}_t in (19) in matrix form, as

$$\underline{y} = \begin{bmatrix} \underline{y}_1 & \underline{y}_2 & \dots & \underline{y}_N \end{bmatrix}^\top = \underbrace{\begin{bmatrix} \underline{h}_1 & \underline{0} & \dots & \underline{0} & \underline{0} \\ a_2 g_2 \underline{h}_2 & \underline{h}_1 & \dots & \underline{0} & \underline{0} \\ \vdots & \vdots & \ddots & \vdots & \vdots \\ \underline{0} & \underline{0} & \dots & \underline{h}_1 & \underline{0} \\ \underline{0} & \underline{0} & \dots & a_K g_K \underline{h}_K & \underline{h}_1 \end{bmatrix}}_H \underbrace{\begin{bmatrix} x_1 \\ x_2 \\ \vdots \\ x_{N-1} \\ x_N \end{bmatrix}}_{\underline{x}} + \underbrace{\begin{bmatrix} \underline{w}_1 \\ a_2 z_2 \underline{h}_2 + \underline{w}_2 \\ \underline{w}_3 \\ a_3 z_3 \underline{h}_3 + \underline{w}_4 \\ \vdots \\ \underline{w}_{N-1} \\ a_K z_K \underline{h}_K + \underline{w}_N \end{bmatrix}}_{\underline{v}}. \quad (20)$$

Given H , the instantaneous mutual information between the transmitted signal \underline{x} and the received signal \underline{y} is

$$\begin{aligned} I(\underline{x}; \underline{y} | H) &= \log_2 \det(K_v + \text{SNR} H H^\dagger) - \log_2 \det(K_v) \\ &= \sum_{i=2}^K \log_2 \det(I_2 + \text{SNR} H_i^\dagger K_i^{-1} H_i), \end{aligned} \quad (21)$$

where

$$K_v = \mathbb{E}(\underline{v} \underline{v}^\dagger), \quad H_i = \begin{bmatrix} \underline{h}_1 & \underline{0} \\ a_i g_i \underline{h}_i & \underline{h}_1 \end{bmatrix}, \quad \text{and } K_i = \begin{bmatrix} I_{n_r} & \\ & I_{n_r} + |a_i|^2 \underline{h}_i \underline{h}_i^\dagger \end{bmatrix}. \quad (22)$$

Thus, the outage probability for Scheme 2 is given by

$$\Pr \left\{ H : \sup_{|a_i|^2 \leq \frac{\text{SNR}}{1 + \text{SNR}|g_i|^2}} I(\underline{x}; \underline{y} | H) < 2K(K - 1)r \log_2 \text{SNR} \right\} \doteq \text{SNR}^{-d_2(r)}, \quad (23)$$

where the target information rate $2K(K - 1)r \log_2 \text{SNR}$ arises from the facts that

- (i) the scheme takes K phases to complete, and
- (ii) each phase requires $2(K - 1)$ channel uses.

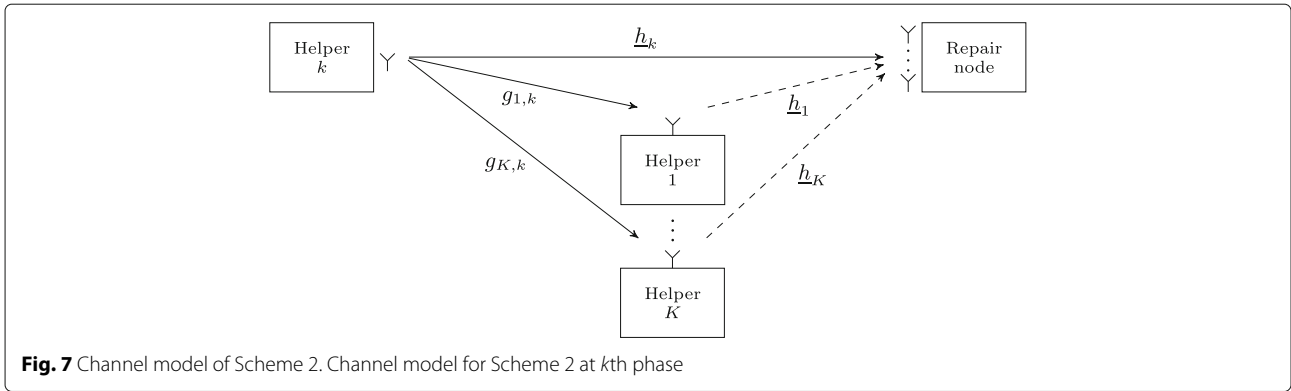

Fig. 7 Channel model of Scheme 2. Channel model for Scheme 2 at kth phase

5.2 DMT achieved by Scheme 2 when $n_r = 1$

When $n_r = 1$, it can be seen that the DMT achieved by Scheme 2 is exactly the DMT for the NAF protocol derived by Azarian et al. [38] with $K - 1$ relays and multiplexing gain Kr . Hence, the following result is immediate from [38].

Theorem 2. *The DMT achieved by Scheme 2 when $n_r = 1$ is the following*

$$d_2(r) \Big|_{n_r=1} = (1 - Kr)^+ + (K - 1)(1 - 2Kr)^+. \quad (24)$$

In Fig. 8, we plot the DMT performance achieved by this scheme for the case of $K = 10$ helper nodes. We also include the base-line TDMA scheme for comparison. It can be seen that the proposed scheme has a better DMT performance than $d_{n_t, n_r, K}^*(r)$ for $r \leq \frac{1}{2K+1} = \frac{1}{21}$, due to the use of additional inter-helper links.

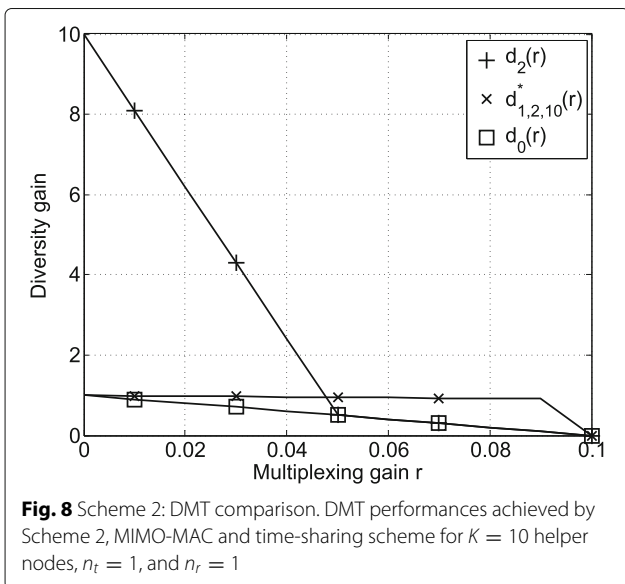

Fig. 8 Scheme 2: DMT comparison. DMT performances achieved by Scheme 2, MIMO-MAC and time-sharing scheme for $K = 10$ helper nodes, $n_t = 1$, and $n_r = 1$

5.3 Upper and lower bounds on $d_2(r)$ with general n_r

Analyzing the outage probability (23) turns out to be very challenging in general when the repairing node has multiple antennas, i.e., $n_r \geq 2$. Almost all existing works such as [38, 47] consider only the case $n_r = 1$. In [39] Yang and Belfiore investigated the DMT for the MIMO-NAF protocol and provided a lower bound for such DMT. Their result can be modified to yield a lower bound for $d_2(r)$. We will comment more on that particular lower bound at the end of this subsection.

To provide bounds on the DMT $d_2(r)$ for general values of n_r , let U be an $(n_r \times n_r)$ unitary matrix such that $U \underline{h}_1 = [\|\underline{h}_1\| \ 0 \ \dots \ 0]^T := \underline{h}$.

For H_i defined in (22), $i = 2, \dots, K$, we get

$$\text{diag}(U, U)H_i = \begin{bmatrix} U & \\ & U \end{bmatrix} H_i = \begin{bmatrix} \underline{h} & 0 \\ a_i g_i \underline{\ell}_i & \underline{h} \end{bmatrix} = S_i, \quad (25)$$

where $\underline{\ell}_i = U \underline{h}_i$ has the same probability density function as \underline{h}_i , $i = 2, \dots, K$. Let $\Sigma_i := I_{n_r} + |a_i|^2 \underline{h}_i \underline{h}_i^\dagger$. Clearly, we have the following partial ordering for positive-definite matrices,

$$I_{n_r} < \Sigma_i < (1 + |a_i|^2 \|\underline{h}_i\|^2) I_{n_r} = (1 + |a_i|^2 \|\underline{\ell}_i\|^2) I_{n_r},$$

which in turn implies $\frac{1}{1 + |a_i|^2 \|\underline{\ell}_i\|^2} I_{n_r} < \Sigma_i^{-1} < I_{n_r}$. With the above, $I(\underline{x}; \underline{y} | H)$ can be upper bounded by

$$\begin{aligned} I(\underline{x}; \underline{y} | H) &\leq \sum_{i=2}^K \log_2 \det \left(I_2 + \text{SNR} H_i^\dagger H_i \right) \\ &= \sum_{i=2}^K \log_2 \left[(1 + \text{SNR} \|\underline{h}_i\|^2)^2 + \text{SNR} |a_i g_i|^2 \|\underline{\ell}_i\|^2 \right. \\ &\quad \left. + \text{SNR}^2 |a_i g_i|^2 \|\underline{h}_i\|^2 \sum_{j=2}^{n_r} |\ell_{ij}|^2 \right]. \end{aligned} \quad (27)$$

Similarly, set $c_i = \frac{1}{1+|a_i|^2\|\underline{\ell}_i\|^2}$, and $I(\underline{x}; \underline{y} | H)$ is lower bounded by

$$I(\underline{x}; \underline{y} | H) \geq \sum_{i=2}^K \log_2 \det \left(I_2 + \text{SNR} S_i^\dagger \begin{bmatrix} I_{n_r} & \\ & c_i I_{n_r} \end{bmatrix} S_i \right) \quad (28)$$

$$= \sum_{i=2}^K \log_2 \left[1 + (1 + c_i) \text{SNR} \|\underline{h}\|^2 + c_i |a_i g_i|^2 \|\underline{\ell}_i\|^2 \text{SNR} + c_i \text{SNR}^2 \|\underline{h}\|^4 + c_i^2 |a_i g_i|^2 \text{SNR}^2 \|\underline{h}\|^2 \sum_{j=2}^{n_r} |\ell_{i,j}|^2 \right]. \quad (29)$$

Equations (27) and (29) then yield the following theorem for bounding the DMT $d_2(r)$ for Scheme 2.

Theorem 3. *The DMT $d_2(r)$ of Scheme 2 for a general number $n_r \geq 1$ of receive antennas at the repairing node has the following upper bound $d_{2,U}(r)$ and lower bound $d_{2,L}(r)$:*

$$d_{2,U}(r) := \inf_g \sup_{b \leq g} \inf_{(\alpha, \beta_1, \beta_2) \in \mathcal{A}_U(r, b, g)} n_r \alpha + (K - 1) \beta_1 + (n_r - 1)(K - 1) \beta_2 + (K - 1)g \quad (30)$$

$$d_{2,L}(r) := \inf_g \sup_{b \leq g} \inf_{(\alpha, \beta_1, \beta_2) \in \mathcal{A}_L(r, b, g)} n_r \alpha + (K - 1) \beta_1 + (n_r - 1)(K - 1) \beta_2 + (K - 1)g \quad (31)$$

where

$$\mathcal{A}_U(r, b, g) = \left\{ \alpha, \beta_1, \beta_2 \in [0, 1] : \max \begin{bmatrix} 2(1 - \alpha), \\ 1 + b - g - \min\{\beta_1, \beta_2\}, \\ 2 + b - g - \beta_2 \end{bmatrix} \leq 2Kr \right\} \quad (32)$$

and

$$\mathcal{A}_L(r, b, g) = \left\{ \alpha, \beta_1, \beta_2 \in [0, 1] : \max \begin{bmatrix} 1 - \alpha, \\ 2 - 2\alpha - (b - \beta)^+, \\ 1 - \beta + b - g - (b - \beta)^+, \\ 2 - \alpha + b - g - \beta_2 - 2(b - \beta)^+ \end{bmatrix} \leq 2Kr \right\}. \quad (33)$$

Proof. Note that the random variables g_i 's are i.i.d., hence there is no need to distinguish them in (27) and (29) when deriving the DMT. The same holds also true for a_i , $\underline{\ell}_i$, and its elements $\ell_{i,j}$ for $i = 2, \dots, K$. Thus, we set

$|a_i|^2 \doteq \text{SNR}^b$, $|g_i|^2 \doteq \text{SNR}^{-g}$, $\|\underline{h}\|^2 \doteq \text{SNR}^{-\alpha}$, $\|\underline{\ell}_i\|^2 \doteq \text{SNR}^{-\beta}$, and $|\ell_{i,j}|^2 \doteq \text{SNR}^{-\beta_j}$ with $\beta = \min_{j=1, \dots, n_r} \beta_j$. Moreover, we note that $\|\underline{h}\|^2$ is a χ^2 random variable with $2n_r$ degrees of freedom, hence it contributes the term $n_r \alpha$ to (27). Each $\underline{\ell}_i$ consists of n_r i.i.d. $\mathcal{CN}(0, 1)$ complex random variables, and there is no need to distinguish $\ell_{i,j}$ for $i = 2, \dots, K$ and for $j = 2, \dots, n_r$ as can be seen from (27) and (29). Hence, we can set $|\ell_{i,j}|^2 \doteq \text{SNR}^{-\beta_2}$ for $i = 2, \dots, K$ and for $j = 2, \dots, n_r$. Similarly, there is no need to distinguish $\ell_{i,1}$ for $i = 2, \dots, K$, hence we set $|\ell_{i,1}|^2 \doteq \text{SNR}^{-\beta_1}$ for $i = 2, \dots, K$. Finally, note that $|g_i|^2$ and $|\ell_{i,j}|^2$ are i.i.d. χ^2 random variables with two degrees of freedom. Plugging the above into (27) and (29) and applying the Laplace principle as in [27] yield the desired upper and lower bounds (30) and (31). \square

In Fig. 9, we plot the DMT bounds $d_{2,L}(r)$ and $d_{2,U}(r)$ of Scheme 2 as well as the DMT $d_{1,2,10}^*(r)$ with $K = 10$ helper nodes, $n_t = 1$ and $n_r = 2$. While there is a gap between bounds $d_{2,L}(r)$ and $d_{2,U}(r)$ when the multiplexing gain r is small, it can be clearly seen that Scheme 2 can offer a better DMT performance than $d_{1,2,10}^*(r)$ when r is small. Regarding the sharpness of $d_{2,L}(r)$ and $d_{2,U}(r)$, let us focus on the case when r is approaching zero from the right, i.e., when $r \downarrow 0$. Note that there are nine SISO channels from helper node 1 to the remaining helper nodes, and the channel between node 1 and the repairing node is a (1×2) SIMO channel. Therefore, the communication to the repairing node would be in outage if the nine SISO channels and the (1×2) SIMO channel are all in deep fade, thereby yielding a maximal diversity order of $9 + 2 = 11$. We therefore conclude that the upper bound $d_{2,U}(r)$ can be further improved.

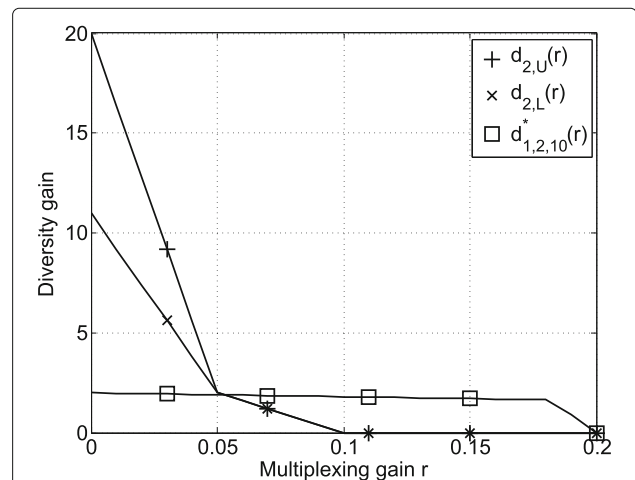

Fig. 9 Scheme 2: DMT bounds and comparison. DMT performances achieved by Scheme 2 (lower bound and the first upper bound) and MIMO-MAC for $K = 10$ helper nodes, $n_t = 1$, and $n_r = 2$

$$\Pr \left\{ H: \sup_{|a_i|^2 \leq \frac{\text{SNR}}{1+\text{SNR}|g_i|^2}} I(\underline{x}; \underline{y} | H) < 2K(K-1)r \log_2 \text{SNR} \right\} \geq \Pr \left\{ H: I(\underline{x}; \underline{y}_U | H) < 2K(K-1)r \log_2 \text{SNR} \right\} \tag{40}$$

$$\doteq \text{SNR}^{-d_{2,U}(r)}. \tag{41}$$

Theorem 4. The DMT $d_2(r)$ for Scheme 2 for a general number $n_r \geq 1$ of receive antennas at the repairing node is upper bounded by

$$d_{2,U}(r) = \begin{cases} (n_r + K - 1)(1 - Kr)^+, & \text{if } n_r \geq K - 1, \\ 2n_r(1 - Kr)^+ + (K - 1 - n_r)(1 - 2Kr)^+, & \text{if } n_r \leq K - 1. \end{cases} \tag{42}$$

Proof. Similar to the proof of Theorem 3, it is unnecessary to distinguish the random variables g_i in (39) for $i = 2, \dots, K$ when calculating the DMT. Thus, let $\|\underline{h}_1\|^2 = \text{SNR}^{-\alpha}$ and $|g_i|^2 = \text{SNR}^{-\beta}$. Note $\|\underline{h}_1\|^2$ is a χ^2 random variable with $2n_r$ degrees of freedom and $|g_i|^2$ is a χ^2 random variable with 2 degrees of freedom. Plugging the above into (41) and applying the Laplace principle as in [27] gives

$$d_{2,U}(r) = \inf_{\mathcal{B}(r)} n_r \alpha + (K - 1)\beta,$$

where

$$\mathcal{B}(r) = \{ \alpha, \beta \in [0, 1] : 1 - \alpha + \max\{1 - \alpha, 1 - \beta\} \leq 2Kr \} \\ = \{ \alpha, \beta \in [0, 1] : 2(1 - \alpha) + (\alpha - \beta)^+ \leq 2Kr \}.$$

Solving the above optimization problem gives the desired result. \square

In Fig. 11, we plot $d_{2,L}(r)$, $d_{2,U}(r)$, and $d_{2,U}(r)$ for the second proposed scheme with $K = 10$ helper nodes, $n_t = 1$ and $n_r = 2$. It can be seen that $d_{2,L}(r) = d_{2,U}(r)$ for all values of r , hence we have $d_2(r) = d_{2,L}(r) = d_{2,U}(r)$ in this case.

5.5 Remarks on the complexity exponents of Scheme 2

Determining the complexity exponents of the second scheme requires much more effort than determining the DMT. At least two major difficulties must be resolved before any identification of complexity exponents is possible. Notice that the notion of complexity exponents resides in an actual construction of space-time codes for the scheme, and that the complexity exponents can vary from one code to another. Codes with a smaller complexity exponent are more favorable in practice, provided that the codes are optimal in the DMT sense, i.e., achieve the DMT $d_2(r)$. Therefore, we have to at least identify a space-time code for Scheme 2 first. In [39], Yang and Belfiore provided a systematic construction of space-time

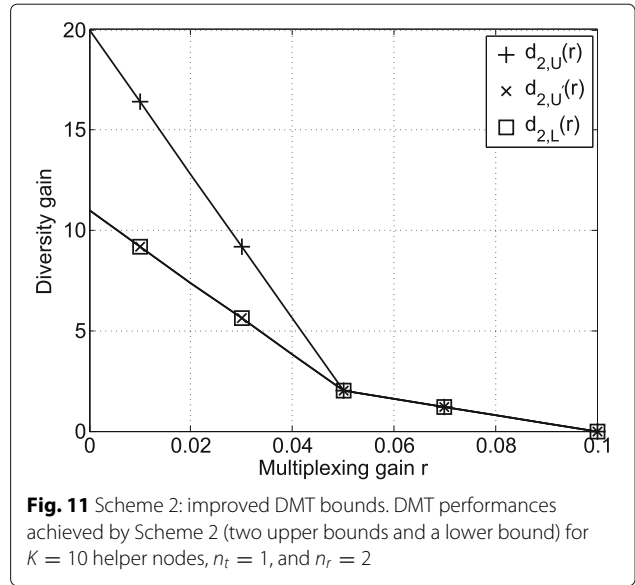

Fig. 11 Scheme 2: improved DMT bounds. DMT performances achieved by Scheme 2 (two upper bounds and a lower bound) for $K = 10$ helper nodes, $n_t = 1$, and $n_r = 2$

codes that is *approximately universal* [48] for NAF-based cooperative relay communications. It is certainly possible to adapt their construction to the transmission using Scheme 2.

The second issue complicating the investigation of complexity exponents arises from the need of an exact characterization of eigenvalues of the matrices $H_i^\dagger K_i^{-1} H_i$ for $i = 2, \dots, K$, appearing in (21). Determining these eigenvalues is particularly difficult. It is in fact the main reason preventing us from obtaining an exact expression for $d_2(r)$ in previous subsections, and we are only able to provide bounds on $d_2(r)$ in this paper.

Nevertheless, it can be seen from (20) that the equivalent channel matrix H is of size $(Nn_r \times N)$ and has linearly independent columns with probability 1. This implies that when applying a sphere decoder to decode the codes—for instance, the code constructed by Yang and Belfiore [39]—transmitted using Scheme 2, the QR decomposition of the matrix H would result in an upper triangular matrix R ; hence, there is no ambiguity to be resolved prior to processing the root of the sphere decoding tree. Therefore, the code must be efficiently sphere decodable.

6 Scheme 3: $n_t = 1$, $n_r \geq 2$, and K helper nodes

In the previous section, we presented a powerful scheme that makes a good use of the inter-helper links to improve the DMT performance of DSS repair transmission. The scheme allows one helper node to transmit information in each phase, and the remaining helper nodes are regarded as relays. Furthermore, we have introduced a novel technique that allows us to upper-bound the DMT for the NAF protocol in a cooperative relay network with multiple antennas at the repairing node. In this section, we will present our third scheme, which can be seen as an

enhancement of Schemes 1 and 2 and can provide a further improvement on the DMT performance.

The third proposed scheme concerns the case $n_t = 1$, $n_r \geq 2$ and K helper nodes. It allows L helper nodes, $L \leq \min\{n_r, K - 1\}$, to transmit simultaneously and non-cooperatively to the repairing node as well as to the remaining $(K - L)$ helper nodes, which will function as relays⁹ in the network. To achieve an average multiplexing gain r , each of the selected L helper nodes must transmit at a higher multiplexing gain of $\frac{K}{L}r$. In particular, we could later seek to improve the overall DMT performance by optimizing over the choices of L . Therefore, L can actually be a function of the multiplexing gain r .

Given L , the third scheme consists of $\binom{K}{L}$ phases, one for each possible L -subset $\mathcal{L} = \{i_1, \dots, i_L\}$ of \mathcal{K} , where $\mathcal{K} = \{1, 2, \dots, K\}$ is the set of helper nodes. The helper nodes in set \mathcal{L} transmit simultaneously and non-cooperatively throughout the phase, which has a duration of $N = 2(K - L)$ channel uses. The remaining nodes in $\mathcal{K} \setminus \mathcal{L} = \{j_1, \dots, j_{K-L}\}$ will function as relays following the NAF protocol. Details of this scheme are given as below, and a pictorial description of this scheme is given in Fig. 12.

Scheme 3

- 1: Let L be an integer with $1 \leq L \leq \min\{n_r, K - 1\}$.
- 2: **for** each $\mathcal{L} = \{i_1, \dots, i_L\} \subseteq \mathcal{K}$ **do**
- 3: **for** $t = 1, 2, \dots, N = 2(K - L)$ **do**
- 4: At the t th channel use of the phase associated with \mathcal{L} , each helper node $i_\ell \in \mathcal{L}$ broadcasts a signal $x_{i_\ell, t}$, with $\mathbb{E}|x_{i_\ell, t}|^2 \leq \text{SNR}$, to the nodes in $\mathcal{K} \setminus \mathcal{L}$ and to the repairing node
- 5: Helper-node $j_s \in \mathcal{K} \setminus \mathcal{L}$, $s = 1, \dots, (K - L)$, receives the following signal when t is odd

$$r_{j_s, t} = \sum_{\ell=1}^L g_{j_s, i_\ell} x_{i_\ell, t} + z_{j_s, t}, \quad (43)$$

where g_{j_s, i_ℓ} and $z_{j_s, t}$ are i.i.d. $\mathbb{C}\mathcal{N}(0, 1)$ random variables defined in (2). When $t = 2s$, node j_s broadcasts the signal $a_{j_s} r_{j_s, 2s-1}$, where a_{j_s} is chosen such that

$$|a_{j_s}|^2 \leq \frac{\text{SNR}}{1 + \text{SNR} \sum_{\ell=1}^L |g_{j_s, i_\ell}|^2}. \quad (44)$$

- 6: The signal received at the repairing node at the t -th channel use of the phase associated with \mathcal{L} is

$$y_t = \begin{cases} \sum_{\ell=1}^L h_{i_\ell} x_{i_\ell, t} + w_t, & t \text{ odd} \\ \sum_{\ell=1}^L h_{i_\ell} x_{i_\ell, t} + h_{j_s} a_{j_s} r_{j_s, t-1} + w_t, & t = 2s \end{cases} \quad (45)$$

- 7: **end for**
- 8: **end for**

6.1 DMT analysis for Scheme 3

The communication channel deduced from Scheme 3 resembles the *multiple-access relay channel* (MARC), which was first introduced by Kramer and van Wijngaarden [49]. The DMTs for the two-user and single-relay MARC—in terms of our notation this means $n_t = 1$, $n_r = 1$, $K = 3$ and $L = 2$ —using various protocols have been studied in the past. For instance, Azarian et al. [50] investigated the DMT for such MARC using the dynamic-decode-and-forward (DDF) strategy, and Yuksel and Erkip [51] focused on the compress-forward (CF) protocol. Furthermore, a protocol similar to Scheme 3 was proposed in [40] and was termed *multiple-access amplify-and-forward* (MAF), which is a variation of the NAF protocol. It was found in [40] that the MAF outperforms the DDF in the high multiplexing gain regime and the CF protocol [51] in the low multiplexing gain regime when $n_t = 1$, $n_r = 1$, $K = 3$, and $L = 2$. The MAF thus provides a nice balance between complexity and performance.

Scheme 3 considers a much more complicated scenario than the one in [40], with $n_t = 1$, and general values of n_r , K and $L \leq \min\{n_r, K - 1\}$. To the best of our knowledge, the DMT analysis for the MAF protocol has never been taken to such complexity level. On the other hand, our novel bounding technique employed in the proof of Theorem 4 is extremely powerful and enables us to analyze the DMT for general MARC using the MAF protocol.

To this end, for any subset $\mathcal{U} = \{u_1, \dots, u_k\} \subseteq \mathcal{L}$ of the selected helper nodes, let $\mathcal{E}_{\mathcal{U}}$ denote the event that helper nodes u_1, \dots, u_k are in outage. The probability for $\mathcal{E}_{\mathcal{U}}$ is given by

$$\begin{aligned} & \Pr\{\mathcal{E}_{\mathcal{U}}\} \\ &= \Pr\left\{\left\{h_{i_\ell}\right\}_{i=1}^K, \left\{g_{i,j}\right\}_{i,j=1}^K : \sup_{\substack{a_{j_s} \\ s=1, \dots, K-L}} I\left(x_{u,t} : u \in \mathcal{U}\right)_{t=1}^N ; y_1, \dots, y_N \right. \\ & \quad \left. \left\{x_{u,t} : u \in \mathcal{L} \setminus \mathcal{U}\right\}_{t=1}^N, \left\{h_{i_\ell}\right\}_{i=1}^K, \left\{g_{i,j}\right\}_{i,j=1}^K\right\} < \frac{NK}{L} r k \log_2 \text{SNR}, \end{aligned} \quad (46)$$

where $N = 2(K - L)$. The overall outage probability for the third proposed scheme with given L is

$$P_{\text{out},3}(L, r) := \Pr\left\{\bigcup_{\mathcal{U} \subseteq \mathcal{L}} \mathcal{E}_{\mathcal{U}}\right\} \doteq \max_{\mathcal{U} \subseteq \mathcal{L}} \Pr\{\mathcal{E}_{\mathcal{U}}\} \doteq \text{SNR}^{-d_3(L, r)}. \quad (47)$$

The technique introduced in Section 5.4 can be applied to yield the following upper bound on $d_3(L, r)$.

ordered eigenvalues of $H_{\mathcal{U}}^{\dagger}H_{\mathcal{U}}$, since $\text{rank}(H_{\mathcal{U}}^{\dagger}H_{\mathcal{U}}) = k$ with probability one. The instantaneous mutual information $I(\mathbf{x}; \mathbf{y}_{\mathcal{U}} | H_{\text{eq}})$ can be further simplified to

$$\begin{aligned} & I(\mathbf{x}; \mathbf{y}_{\mathcal{U}} | H_{\text{eq}}) \\ &= N \sum_{s=1}^k \log_2(1 + \text{SNR}\lambda_s) \\ & \quad + \sum_{s=1}^{\frac{N}{2}} \log_2 \left(I_k + (I_k + \text{SNR}\Lambda)^{-1} \text{SNR} E^{\dagger} \mathbf{g}_s^* \mathbf{g}_s^{\top} E \right) \\ &= N \sum_{s=1}^k \log_2(1 + \text{SNR}\lambda_s) \\ & \quad + \sum_{s=1}^{\frac{N}{2}} \log_2 \left(1 + \sum_{j=1}^k \frac{\text{SNR}}{1 + \text{SNR}\lambda_j} |v_{s,j}|^2 + \sum_{j=k+1}^{n_r} \text{SNR} |v_{s,j}|^2 \right), \end{aligned} \tag{52}$$

where we have set $v_s = E^{\dagger} \mathbf{g}_s^*$, which is a length- n_r random vector with i.i.d. $\mathcal{CN}(0, 1)$ entries. It follows that

$$\Pr \{ \mathcal{E}_{\mathcal{U}} \} \geq \Pr \left\{ I(\mathbf{x}; \mathbf{y}_{\mathcal{U}} | H_{\text{eq}}) < \frac{NK}{L} r k \log_2 \text{SNR} \right\} \doteq \text{SNR}^{-d_{\mathcal{U}}(r)}. \tag{53}$$

We set

- $\lambda_s = \text{SNR}^{-\alpha_s}$ for $s = 1, \dots, \frac{N}{2}$, with each α_s contributing the term $(2s - 1 + (n_r - k))\alpha_s$ to the overall diversity order.
- $|v_{s,j}|^2 = \text{SNR}^{-\beta_{s,j}} = \text{SNR}^{-\beta_j}$ for $s = 1, \dots, \frac{N}{2}$ and $j = 1, \dots, k$, since there is no need to distinguish $v_{s,j}$ in these cases when applying the Laplace principle to (53). Each $\beta_j, j = 1, \dots, k$, contributes the term $\frac{N}{2}\beta_j$ to the overall diversity order.
- $|v_{s,j}|^2 = \text{SNR}^{-\beta_{s,j}} = \text{SNR}^{-\beta_{k+1}}$ for $s = 1, \dots, \frac{N}{2}$ and $j = k + 1, \dots, n_r$, for the same reason. The factor β_{k+1} contributes the term $\frac{N}{2}(n_r - k)\beta_{k+1}$ to the overall diversity order.

It follows from the above that

$$\begin{aligned} d_{\mathcal{U}}(r) := & \inf_{\mathcal{A}'(L,k,r)} \sum_{i=1}^k [2i - 1 + (n_r - k)] \alpha_i + (K - L) \sum_{j=1}^k \beta_j \\ & + (K - L)(n_r - k)\beta_{k+1}, \end{aligned} \tag{54}$$

where

$$\mathcal{A}'(L, k, r) := \left\{ \begin{array}{l} \alpha_1, \dots, \alpha_k, \beta_1, \dots, \beta_{k+1} \in \mathbb{R} : \\ \alpha_1 \geq \alpha_2 \geq \dots \geq \alpha_k \geq 0, \beta_1, \beta_2, \dots, \beta_{k+1} \geq 0, \\ \beta_{k+1} = 0 \text{ if } n_r = k, \\ \sum_{i=1}^k (1 - \alpha_i)^+ + \frac{1}{2} \max\{(1 - \beta_j - (1 - \alpha_j)^+)^+, \dots, \\ (1 - \beta_k - (1 - \alpha_k)^+)^+, \beta_{k+1}\} < \frac{Kk}{L} \end{array} \right\} \tag{55}$$

Finally, the upper bound $d_{3,\mathcal{U}}(L, r)$ is obtained after minimizing $d_{\mathcal{U}}(r)$ for all possible subsets $\mathcal{U} \subseteq \mathcal{L}$ (or equivalently for all $k = 1, \dots, L$) and after simplifying the constraints in (55). \square

By optimizing over all possible $L = 1, 2, \dots, \min\{n_r, K - 1\}$ for $d_{3,\mathcal{U}}(r)$, we obtain an upper bound on the DMT performance for the third scheme.

Corollary 6. *The DMT performance for Scheme 3 is upper bounded by*

$$d_{3,\mathcal{U}}(r) := \max_{L=1, \dots, \min\{K-1, n_r\}} d_{3,\mathcal{U}}(L, r). \tag{56}$$

In Fig. 13, we illustrate the overall picture for the case of $n_t = 1, n_r = 2$, and $K = 10$. While we do not yet have a lower bound or a tight DMT result, we believe that Scheme 3 is indeed likely to be superior¹⁰ to all other schemes presented in this paper, namely the TDMA scheme, Schemes 1 and 2.

In particular, we note that the DMT upper bound for Scheme 3 achieves the maximal possible multiplexing gain of $\frac{2}{10} = 0.2$, which is the same as the TDMA scheme and the MIMO-MAC. Such possibility for the optimality of Scheme 3 turns out to be generally true, at least from the viewpoint of the upper bound (51). To see this, note that by (51), we have

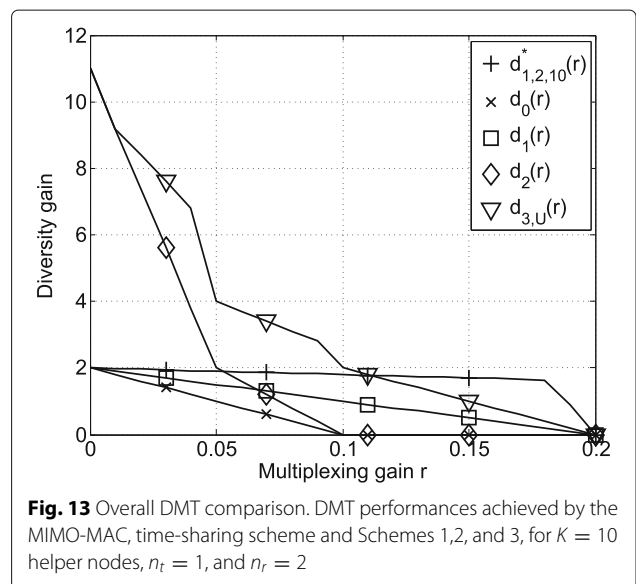

Fig. 13 Overall DMT comparison. DMT performances achieved by the MIMO-MAC, time-sharing scheme and Schemes 1, 2, and 3, for $K = 10$ helper nodes, $n_t = 1$, and $n_r = 2$

$$\begin{aligned}
& \mathbb{E} \left[\frac{I(\underline{x}; \underline{y}_{\mathcal{L}} | H_{\text{eq}})}{N \log_2 \text{SNR}} \right] \\
&= \frac{\mathbb{E} \frac{1}{2} \log_2 \det \left(I_L + \text{SNR} H_{\mathcal{L}}^\dagger H_{\mathcal{L}} \right) + \frac{1}{2} \mathbb{E} \log_2 \det \left(I_L + \text{SNR} H_{\mathcal{L}}^\dagger H_{\mathcal{L}} + \text{SNR} \underline{g}_1^* \underline{g}_1^\top \right)}{\log_2 \text{SNR}} \\
&= \frac{1}{2} \min\{L, n_r\} + \frac{1}{2} \min\{L, n_r + 1\} + o(1), \tag{57}
\end{aligned}$$

as $\text{SNR} \rightarrow \infty$, where the last equality follows from the asymptotic analysis of the degrees-of-freedom (DoF) for the MIMO channel [27, 52] and from the fact that $H_{\mathcal{L}}$ is a channel matrix of size $(n_r \times L)$, and $H_{\mathcal{L}}^\dagger H_{\mathcal{L}} + \underline{g}_1^* \underline{g}_1^\top = FF^\dagger$ with $F = [H_{\mathcal{L}}^\dagger \underline{g}_1^*]$ is a matrix of size $(L \times (n_r + 1))$. Eq. 57 shows that the channel capacity resulting from Scheme 3 equals $L \cdot \log_2 \text{SNR} + O(\log_2 \text{SNR})$ in high SNR regime for $L \leq \min\{n_r, K - 1\}$, and such an amount of capacity is shared by the L selected helper nodes. In other words, each selected helper node gets $1 \cdot \log_2 \text{SNR} + O(\log_2 \text{SNR})$ bits per channel use as the maximal achievable transmission rate. Note that in Scheme 3 the selected helper node must transmit at a higher multiplexing gain $\frac{K}{L}r$ such that the average multiplexing gain equals r . This then implies

$$\frac{K}{L}r \log_2 \text{SNR} \leq 1 \cdot \log_2 \text{SNR} + o(\log_2 \text{SNR}), \tag{58}$$

i.e., $r \leq \frac{L}{K}$. Now, with $L = n_r < K$ we see that Scheme 3 achieves the maximal possible multiplexing gain of $\frac{n_r}{K}$ for each helper node, same as MIMO-MAC [28], where the maximal possible multiplexing gain is given by $\frac{\min\{K, n_r\}}{K} = \frac{n_r}{K}$.

7 Conclusions

The communications within a wireless storage network can be modeled as a multiple-access channel with additional inter-source communication links. Motivated by this observation, we have proposed three physical layer transmission schemes based on different time-sharing and relaying strategies that are suitable for the given channel model. In contrast to the state-of-the-art MAC DMT optimal algebraic space-time codes, our schemes are efficiently sphere-decodable with only one or two antennas. Their DMT performance reaches between the time-sharing DMT and the optimal MAC DMT—the one for conventional MIMO-MAC having no inter-source links—in the high-multiplexing gain regime. When the desired multiplexing gain is low, the schemes even outperform the optimal MAC DMT. Naturally, the schemes are also applicable to DSS file reconstruction, as well as to any MAC communications with inter-source links.

In the future, even small devices with very limited power may be equipped with several antennas thanks to massive MIMO at 60 Hz. However, implementation of a practical massive MIMO system still calls for a considerable amount of research efforts regarding pilot design, channel estimation, and code design. Before all that is realized, we believe that the proposed schemes provide a good and efficient alternative.

Endnotes

¹Device-to-device (D2D) communication networks provide one such example, see e.g. [53, 54].

²Preliminary results related to this work were reported in the Global Wireless Summit 2014 GWS'14 [18] (invited abstract which is considered a preprint), 21st International Symposium on Mathematical Theory of Networks and Systems MTNS'14 [19] (short invited abstract, Scheme 1), and 2014 International Symposium on Information Theory and Its Applications (ISITA) [20] (Schemes 1–3, now combined to Scheme 2). We point out that the numbering of the schemes has been changed so that the schemes previously called 2 and 3 [20] have been combined to Scheme 2, and the new scheme is hence now called Scheme 3 and has not appeared anywhere before. This paper extends the results by additional proofs for the bounds related to Scheme 2, and with a completely new scheme, Scheme 3, that improves upon the other schemes.

³By efficiently sphere-decodable space-time code we mean that the code can be sphere-decoded without the need of performing an exhaustive search for part of the symbols before starting processing the root of a sphere-decoding tree. See discussions in Section 2.2.

⁴By half-duplex we mean each node can choose to either transmit or receive, but not both at the same time.

⁵Such a comparison might not seem fair to some readers as (5) assumes no inter-helper links. However, the DMT (5) is the best DMT result that can be found in the related literature.

⁶This latter condition might seem unrealistic in certain (logical) distributed storage codes. However, it would be extremely difficult to determine the mutual information between the helpers and the repairing node if one takes into account the shared information among helper nodes.

⁷A lattice is a discrete abelian subgroup of a real or complex vector space, and its rank is given by its rank as a module over \mathbb{Z} . By an algebraic lattice we refer to one constructed from a number field extension or a division algebra, see e.g. [29].

⁸It is unfortunate that measuring the exact complexity exponents for these schemes is extremely complicated, and we are unable to complete the task in this paper. Nevertheless, it can still be seen that these schemes can yield efficiently sphere-decodable space-time codes without the need of resolving ambiguities when processing the sphere-decoding tree.

⁹Here we have implicitly assumed $K - L \geq 1$ such that at least one helper node will function as a relay.

¹⁰Cf. the corresponding upper bound $d_{2,U'}(r) = d_2(r)$ for Scheme 3 that turned out to be tight.

Competing interests

The authors declare that they have no competing interests.

Acknowledgements

C. Hollanti is supported by the Academy of Finland grants #276031, #282938, and #283262, and by Magnus Ehrnrooth Foundation, Finland. D. Karpuk is supported by the Academy of Finland grant #268364. The support from the European Science Foundation under the ESF COST Action IC1104 is also gratefully acknowledged. The research of H. F. Lu was funded in part by Taiwan Ministry of Science and Technology under Grants MOST 101-2923-E-009-001-MY3 and MOST 103-2221-E-009-043-MY3.

Author details

¹Department of Electrical and Computer Engineering, National Chiao Tung University, ED726, 1001 University Rd., 300 Hsinchu, Taiwan. ²Department of Mathematics and Systems Analysis, Aalto University, P.O. Box 11100, FI-00076 AALTO (Espoo), Finland.

Received: 3 July 2015 Accepted: 9 March 2016

Published online: 05 May 2016

References

1. Extracting value from chaos (2011). www.emc.com/collateral/analyst-reports/idc-extracting-value-from-chaos-ar.pdf, digital Universe Study by the EMC corporation, Accessed 18.11.2015
2. The digital universe of opportunities (2014). <http://www.emc.com/collateral/analyst-reports/idc-digital-universe-2014.pdf>, digital Universe Study by the EMC corporation
3. Cisco visual networking index: Global mobile data traffic forecast update, 2014–2019, white paper (2015). http://www.cisco.com/c/en/us/solutions/collateral/service-provider/ip-ngn-ip-next-generation-network/white_paper_c11-481360.pdf
4. F Oggier, A Datta, Coding techniques for repairability in networked distributed storage systems. *Found. Trends Commun. Inf. Theory*. **9**(4), 383–466 (2013)
5. A Lakshman, P Malik, Cassandra: a decentralized structured storage system. *SIGOPS Oper. Syst. Rev.* **44**(2), 35–40 (2010)
6. R Jennings, *Cloud computing with the Windows Azure platform*. Wiley Publishing (2009)
7. FJ MacWilliams, NJA Sloane, *The theory of error-correcting codes*. North-Holland (1983)
8. AG Dimakis, B Godfrey, Y Wu, MJ Wainwright, K Ramchandran, Network coding for distributed storage systems. *IEEE Trans. Inf. Theory*. **56**(9), 4539–4551 (2010)
9. KV Rashmi, NB Shah, PV Kumar, Optimal exact-regenerating codes for distributed storage at the MSR and MBR points via a product-matrix construction. *IEEE Trans. Inf. Theory*. **57**(8), 5227–5239 (2011)
10. T Ernvall, SE Rouayheb, C Hollanti, HV Poor, Capacity and security of heterogeneous distributed storage systems. *IEEE J. Sel. Areas Commun.* **31**(12), 2701–2709 (2013)
11. SYE Rouayheb, K Ramchandran, in *Proc. 48th Annual Allerton Conference, Sept. 29 2010–Oct. 1 2010*. Fractional Repetition Codes for Repair in Distributed Storage Systems, (Monticello, IL, USA, 2010), pp. 1510–1517
12. J Rabaey, in *Keynote Address. A brand new wireless day (ASPDAC, Seoul, 2008)*
13. J Rabaey, Connectivity brokerage—enabling seamless cooperation in wireless networks. white paper (2010). <https://faculty.ozyegin.edu.tr/aliercan/files/2012/10/Pub6.pdf>
14. J Rabaey, in *Proc. Symp. VLSI Circuits, June 15–17, 2011*. The swarm at the edge of the cloud—a new perspective on wireless, (Honolulu, HI, USA, 2011), pp. 2158–5601
15. E Bastug, M Bennis, M Debbah, Living on the edge: The role of proactive caching in 5g wireless networks. *IEEE Commun. Mag.* **52**(8), 82–89 (2014)
16. C Gong, X Wang, On partial downloading for wireless distributed storage networks. *IEEE Trans. Signal Process.* **60**(6), 3278–3288 (2012)
17. KV Rashmi, NB Shah, K Ramchandran, PV Kumar, in *Proceedings of the 2012 IEEE International Symposium on Information Theory, ISIT 2012, July 16, 2012*. Regenerating codes for errors and erasures in distributed storage, (Cambridge, MA, USA, 2012), pp. 1202–1206
18. C Hollanti, DA Karpuk, A Barreal, HF Lu, Proc. 4th International Conference on Wireless Communications, Vehicular Technology, Information Theory and Aerospace & Electronic Systems (VITAE), May 11–14, 2014, Aalborg, Denmark. Space-time storage codes for wireless distributed storage systems, pp. 1–5 (2014)
19. A Barreal, C Hollanti, DA Karpuk, H Lu, in *Pre-proceedings of the 21st International Symposium on Mathematical Theory of Networks and Systems, MTNS 2014, July 7–11, 2014*. Algebraic Codes and a New Physical Layer Transmission Protocol for Wireless Distributed Storage Systems, (Groningen, The Netherlands, 2014)
20. C Hollanti, H Lu, DA Karpuk, A Barreal, in *Proc. 2014 IEEE International Symposium on Information Theory and its Applications, ISITA 2014, October 26–29, 2014*. New relay-based transmission protocols for wireless distributed storage systems, (Melbourne, VIC, Australia, 2014), pp. 585–589
21. TM Cover, JA Thomas, *Elements of Information Theory*, 2nd. edn. (John Wiley & Sons, New Jersey, 2006)
22. V Tarokh, N Seshadri, AR Calderbank, Space-time codes for high data rate wireless communication: performance criterion and code construction. *IEEE Trans. Inf. Theory*. **44**, 744–765 (1998)
23. P Elia, KR Kumar, SA Pawar, PV Kumar, HF Lu, Explicit space-time codes achieving the diversity–multiplexing gain tradeoff. *IEEE Trans. Inf. Theory*. **52**(9), 3869–3884 (2006)
24. C Hollanti, J Lahtonen, HF Lu, Maximal orders in the design of dense space-time lattice codes. *IEEE Trans. Inf. Theory*. **54**(10), 4493–4510 (2008)
25. JC Belfiore, G Rekaya, E Viterbo, The Golden code: a 2×2 full-rate space-time code with non-vanishing determinants. *IEEE Trans. Inf. Theory*. **51**(4), 1432–1436 (2005)
26. HF Lu, C Hollanti, R Vehkalahti, J Lahtonen, DMT optimal codes constructions for multiple-access MIMO channel. *IEEE Trans. Inf. Theory*. **57**(6), 3594–3617 (2011)
27. L Zheng, DNC Tse, Diversity and multiplexing: a fundamental tradeoff in multiple antenna channels. *IEEE Trans. Inf. Theory*. **49**(5), 1073–1096 (2003)
28. DNC Tse, P Viswanath, L Zheng, Diversity–multiplexing tradeoff in multiple-access channels. *IEEE Trans. Inf. Theory*. **50**(9), 1859–1874 (2004)
29. F Oggier, JC Belfiore, E Viterbo, *Cyclic Division Algebras: a Tool for Space-Time Coding*. (Publishers Inc. PO Box 1024 Hanover, MA 02339 USA, 2007)

30. B Hassibi, M Hochwald, High-rate codes that are linear in space and time. *IEEE Trans. Inf. Theory*. **48**(7), 1804–1824 (2002)
31. B Hassibi, H Vikalo, On the sphere-decoding algorithm I, expected complexity. *IEEE Trans. Signal Process.* **53**(8), 2806–2818 (2005)
32. T Tang, H Tien, HF Lu, Selection and rate-adaptation schemes for MIMO multiple-access channels with low-rate channel feedback. *IEEE Trans. Inf. Theory*. **61**(11), 5948–5975 (2015)
33. TW Tang, MK Chen, HF Lu, Improving the DMT performance for MIMO communication with linear receivers. *IEEE Trans. Veh. Technol.* **62**(3), 1189–1200 (2013)
34. D Tse, P Viswanath, *Fundamentals of Wireless Communication*. (Cambridge, University Press, Cambridge, UK, 2005)
35. J Jaldén, P Elia, Sphere decoding complexity exponent for decoding full-rate codes over the quasi-static MIMO channel. *IEEE Trans. Inf. Theory*. **58**(9), 5785–5803 (2012)
36. HF Lu, P Elia, A Singh, Performance-complexity analysis for MAC ML-based decoding with user selection. *IEEE Trans. Signal Process.* (2014). arxiv.1505.07725
37. JN Laneman, GW Wornell, Distributed space-time-coded protocols for exploiting cooperative diversity in wireless networks. *IEEE Trans. Inf. Theory*. **49**(10), 2415–2425 (2003)
38. K Azarian, H El Gamal, P Schniter, On the achievable diversity-multiplexing tradeoff in half-duplex cooperative channels. *IEEE Trans. Inf. Theory*. **51**(12), 4152–4172 (2005)
39. S Yang, JC Belfiore, Optimal space-time codes for the MIMO amplify-and-forward cooperative channel. *IEEE Trans. Inf. Theory*. **53**(2), 647–663 (2007)
40. D Chen, K Azarian, JN Laneman, A case for amplify-forward relaying in the block-fading multiple-access channel. *IEEE Trans. Inf. Theory*. **54**(8), 3728–3733 (2008)
41. MO Damen, HE Gamal, G Caire, On maximum-likelihood detection and the search for the closest lattice point. *IEEE Trans. Inf. Theory*. **49**(10), 2389–2402 (2003)
42. MO Damen, H El Gamal, G Caire, in *Proc. 2004 IEEE Int. Symp. Inf. Theory*. MMSE-GDFE Lattice Decoding for Solving Under-determined Linear Systems With Integer Unknowns, (Chicago, IL, 2004), p. 538
43. LG Barbero, T Ratnarajah, C Cowan, in *Proceedings of the IEEE International Conference on Acoustics, Speech, and Signal Processing, ICASSP 2008, March 30 - April 4, 2008, Caesars Palace, Las Vegas, Nevada, USA*. A low-complexity soft-mimo detector based on the fixed-complexity sphere decoder, (2008), pp. 2669–2672
44. K Su, Detection and decoding of signals transmitted over linear MIMO channels. PhD thesis, University of Cambridge (2005)
45. J Jaldén, P Elia, DMT optimality of LR-aided linear decoders for a general class of channels, lattice designs, and system models. *IEEE Trans. Inf. Theory*. **56**(10), 4765–4780 (2010)
46. AK Singh, J Jaldén, P Elia, Achieving a vanishing SNR gap to exact lattice decoding at a subexponential complexity. *IEEE Trans. Inf. Theory*. **58**(6), 3692–3707 (2012)
47. P Elia, K Vinodh, M Anand, PV Kumar, D-MG tradeoff and optimal codes for a class of AF and DF cooperative communication protocols. *IEEE Trans. Inf. Theory*. **55**(7), 3161–3185 (2009)
48. S Tavildar, P Viswanath, Approximately universal codes over slow fading channels. *IEEE Trans. Inf. Theory*. **52**(7), 3233–3258 (2006)
49. G Kramer, AJ van Wijngaarden, in *Proc. 2000 IEEE Int. Symp. Inf. Theory*. On the White Gaussian Multiple-access Relay Channel, (Sorrento, Italy, 2000)
50. K Azarian, HE Gamal, P Schniter, On the optimality of the ARQ-DDF protocol. *IEEE Trans. Inf. Theory*. **54**(4), 1718–1724 (2008)
51. M Yuksel, E Erkip, Multiple-antenna cooperative wireless systems: A diversity–multiplexing tradeoff perspective. *IEEE Trans. Inf. Theory*. **53**(10), 3371–3393 (2007)
52. E Telatar, Capacity of multi-antenna Gaussian channels. *Europ. Trans. Telecomm.* **10**(6), 585–595 (1999)
53. J Pääkkönen, C Hollanti, O Tirkkonen, Device-to-device data storage for mobile cellular systems. Device-to-Device (D2D) Communication With and Without Infrastructure, *Globecom 2013*, arXiv:1309.6123 (2013)
54. J Pääkkönen, C Hollanti, O Tirkkonen, Device-to-device data storage with regenerating codes. 8th International Workshop on Multiple Access Communications (MACOM), arXiv:1411.1608 (2015)

Submit your manuscript to a SpringerOpen[®] journal and benefit from:

- Convenient online submission
- Rigorous peer review
- Immediate publication on acceptance
- Open access: articles freely available online
- High visibility within the field
- Retaining the copyright to your article

Submit your next manuscript at ► springeropen.com
