

Review Article

A Review of Optimal Energy Management Strategies for Hybrid Electric Vehicle

Aishwarya Panday and Hari Om Bansal

Department of Electrical and Electronics, B.I.T.S. Pilani, Rajasthan, India

Correspondence should be addressed to Aishwarya Panday; aishwarya.panday@pilani.bits-pilani.ac.in

Received 15 June 2014; Revised 13 October 2014; Accepted 16 October 2014; Published 18 November 2014

Academic Editor: C. S. Shankar Ram

Copyright © 2014 A. Panday and H. O. Bansal. This is an open access article distributed under the Creative Commons Attribution License, which permits unrestricted use, distribution, and reproduction in any medium, provided the original work is properly cited.

Presence of an alternative energy source along with the Internal Combustion Engine (ICE) in Hybrid Electric Vehicles (HEVs) appeals for optimal power split between them for minimum fuel consumption and maximum power utilization. Hence HEVs provide better fuel economy compared to ICE based vehicles/conventional vehicle. Energy management strategies are the algorithms that decide the power split between engine and motor in order to improve the fuel economy and optimize the performance of HEVs. This paper describes various energy management strategies available in the literature. A lot of research work has been conducted for energy optimization and the same is extended for Plug-in Hybrid Electric Vehicles (PHEVs). This paper concentrates on the battery powered hybrid vehicles. Numerous methods are introduced in the literature and based on these, several control strategies are proposed. These control strategies are summarized here in a coherent framework. This paper will serve as a ready reference for the researchers working in the area of energy optimization of hybrid vehicles.

1. Introduction

Hybrid Electric Vehicles (HEVs) and Plug-in Hybrid Electric Vehicles (PHEVs) consist of two power sources, that is, (1) Internal Combustion Engine (ICE) and (2) battery. Power split between these two is of utmost importance to minimize the fuel consumption without affecting the vehicle speed. The literature reveals that various power split strategies have been developed and implemented. These strategies vary in optimization type (global or local), computational time, structural complexity, a priori knowledge of driving pattern, and effectiveness of the algorithm. A survey of these available methods would be of great use for researchers and practitioners working on HEVs/PHEVs.

This paper includes several powerful methods of energy optimization proposed in the literature.

These methods are not mutually exclusive and can be used alone or in combinations. The authors have compiled more than 180 papers cognate with optimal performance of HEVs/PHEVs published till 2012. The authors apologize if any paper, method, or improvement is unintentionally omitted. Figure 1 shows the summary of papers published from

various refereed journals, conferences, and magazines. This data is based on the papers studied and cited in this paper.

2. Emergence of Hybrid Electric Vehicle

Automobiles have made great contribution to the growth of modern society by satisfying the needs for greater mobility in everyday life. The development of ICE has contributed a lot to the automobile sector. But large amounts of toxic emissions in the form of carbon dioxide (CO_2), carbon monoxide (CO), nitrogen oxides (NO_x), unburned hydrocarbons (HCs), and so forth have been causing pollution problems, global warming, and destruction of the ozone layer. These emissions are a serious threat to the environment and human life. Also, as petroleum resources are limited, consumption of petroleum needs to be reduced. One prominent solution to these problems is to go for an alternate transportation technology, which uses ICE as primary power source and batteries/electric motor as peaking power source. This concept has brought the new transportation medium such as Electric Vehicles (EVs), HEVs and PHEVs, which are clean, economical, efficient, and environment friendly.

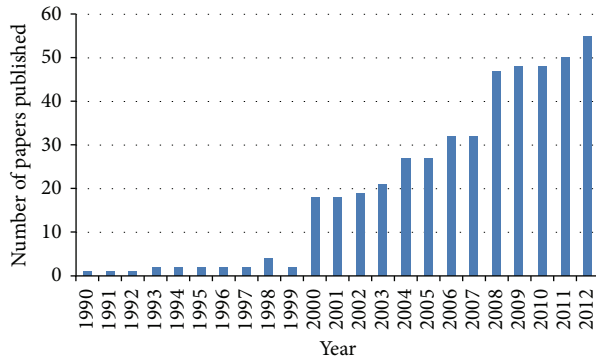

FIGURE 1: Graphical representation of papers published per year.

The EVs are enabled by high efficiency electric motor and controller and powered by alternative energy sources. The first EV was built by a Frenchman Gustave Trouve in 1881. It was a tricycle powered by a 0.1 hp direct current motor fed by lead-acid batteries. EV is a clean, efficient, and environment friendly urban transportation medium but has limited range of operation.

Due to higher battery cost, limited driving range, and performance of EVs, HEVs came into existence. HEVs use both electric machine and an ICE to deliver power during vehicle propulsion. It has advantages of both ICE vehicles and EVs and eliminates their disadvantages [1]. In HEVs battery is the supportive power system to ICE during vehicle propulsion and hence reduces the liquid fuel consumption and toxic emissions. In 1901 Ferdinand Porsche developed the Lohner-Porsche Mixte Hybrid, the first gasoline-electric hybrid vehicle [2].

In HEVs batteries are charged either by engine or by regenerative braking and are not plugged-in externally which limits its electric range. They also take longer time in recharging. PHEVs offer a promising medium-term solution to reduce the energy demand as the batteries are charged through the grid. PHEVs are displacing liquid fuels by storing the energy in a battery with cheaper grid electricity [3]. PHEVs have a large on-board rechargeable battery and larger sized motors compared to HEVs. Presence of larger size battery with high energy capacity increases the fuel efficiency of PHEVs. In PHEVs battery is used as primary power source and ICE as secondary power source. The battery can be recharged through mains power supply anywhere at home, parking lots, or garages.

3. Architecture of Hybrid Electric Vehicles

HEVs are classified mainly into three categories: (1) series hybrid, (2) parallel hybrid, and (3) series-parallel (power-split) hybrid. The series configuration consists of an electric motor with an ICE without any mechanical connection between them. ICE is used for running a generator when the battery does not have enough power to drive the vehicle; that is, ICE drives an electric generator instead of directly driving the wheels. Series hybrids have only one drive train but

require two distinct energy conversion processes for all operations. These two energy conversion processes are gasoline to electricity and electricity to drive wheels. Fisher Karma, Renault Kangoo, Coaster light duty bus, Orion bus, Opel Flextremer, and Swiss auto REX VW polo use series configuration.

In parallel configuration, single electric motor and ICE are installed in such a way that both individually or together can drive the vehicle. Parallel hybrids allow both power sources to work simultaneously to attain optimum performance. While this strategy allows for greater efficiency and performance, the transmission and drive train are more complicated and expensive. Parallel configuration is more complex than the series, but it is advantageous. Honda's Insight, Civic, Accord, General Motors Parallel Hybrid Trucks, BAS Hybrid such as Saturn VAU and Aura Greenline, and Chevrolet Malibu by hybrids utilize parallel configuration.

Power split hybrid has a combination of both series and parallel configuration in a single frame. In this configuration engine and battery can, either alone or together, power the vehicle and battery can be charged simultaneously through the engine. Basically, it extends the all-electric range (AER) of hybrid vehicle. The current dominant architecture is the power-split configuration which is categorized into two modes: (1) one (single) mode and (2) two (dual) modes. Single mode contains one planetary gear set (PGS) and dual mode contains two PGS which are required for a compound power split. It is further classified into three types: (1) input split, (2) output split, and (3) compound split as determined by the method of power delivery.

In the input split power configuration or single mode electromechanical infinitely variable transmission (EVT), planetary gear is located at the input side as shown in Figure 2(a). The input power from the ICE is split at the planetary gear. It gives low efficiency at high vehicle speed [4]. Toyota Prius employs an input split power configuration.

The output split power train consists of one planetary gear at the output side as shown in Figure 2(b). The output split system uses power recirculation at low vehicle speed and power splitting at high vehicle speed. Power recirculation means that a portion of the engine power is recirculated by the charging of any one motor/generator and discharging of the other. Due to charging and discharging efficiency of the motors, recirculated power negatively affects the system efficiency. Hence output split power train displays poor performance at low vehicle speed compared to input split [5]. Chevrolet Volt uses output split configuration.

In dual mode configuration, the two clutches provide a torque advantage of the motor at low speed while fundamentally changing the power flow through the transmission as shown in Figure 2(c). When the first clutch is applied and the second clutch is open, the system operates as an input split. When the second clutch is applied and the first clutch is released, the system operates as a compound split. This hybrid can shift between these two (input-split as well as compound-split) in a synchronous shift, involving only torque transfer between elements without sharp changes in the speeds of any element. Lexus HS250h, Lexus RX400h, Toyota Camry and Highlander, Lexus GS450h, and Lexus

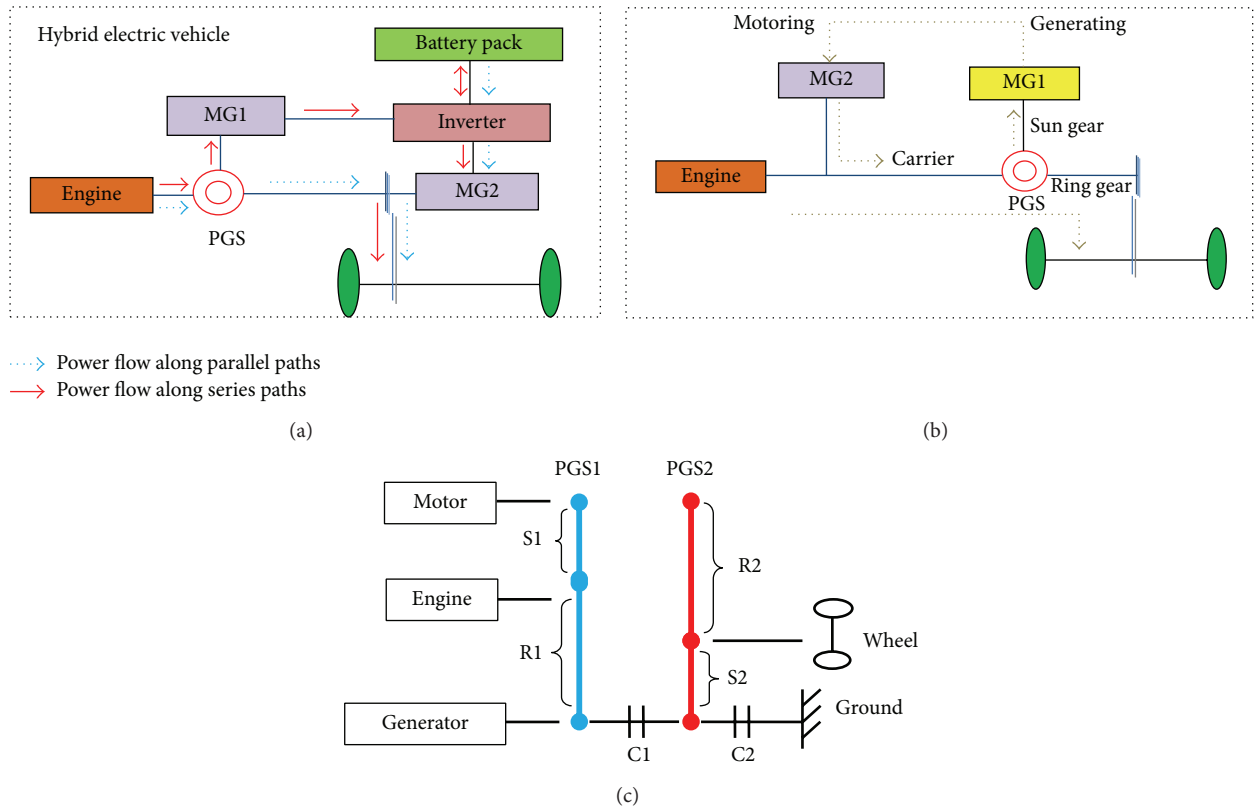

FIGURE 2: Power-split configurations: (a) input split, (b) output split, and (c) compound split.

LS600h use compound split configuration. The combination of a compound split and an input split enables a two-mode hybrid system. The use of dual mode solves the problems of the single mode power train and provides better vehicle performance with respect to fuel economy, acceleration, and motor size. In dual mode, PGS are used for both the input split and compound split [6]. Two-mode hybrids includes General Motors two-mode hybrid full-size trucks and SUVs, BMW X6 Active Hybrid and Mercedes ML 450 hybrid, Allison EV Drive, Chrysler Aspen, Chevrolet Tahoe, and GMC Yukon hybrid (GHC, 2013).

All the configurations of HEV can be employed in PHEV's drive trains. In PHEVs battery is initially charged through the mains power supply to the full capacity, which supports HEV architecture to propel it for longer distances with a very less fuel consumption.

4. Problem Overview

The presence of two power sources focuses on the need of designing an energy management strategy to split power between them. The strategy should be able to minimize the fuel consumption and maximize the power utilization. In HEVs, the battery is a supporting power source which gets charged when ICE powers the vehicle and also through regenerative braking. In HEVs the state of charge (SOC) of the battery is the same at the start and end of the trip; that is, it works in charge sustaining mode. In PHEVs, the batteries

are charged through mains; therefore it can be depleted to the permissible minimum level at the end of the trip; that is, it works in a charge depletion mode. PHEVs may call upon to work in charge sustaining, charge depletion, or combination of both based on the requirement.

5. Overview of Different Optimization Strategies

Due to the complex structure of HEVs/PHEVs, the design of control strategies is a challenging task. The preliminary objective of the control strategy is to satisfy the driver's power demand with minimum fuel consumption and toxic emissions and with optimum vehicle performance. Moreover, fuel economy and emissions minimization are conflicting objectives; a smart control strategy should satisfy a trade-off between them.

Various control strategies are proposed for optimal performance of HEVs/PHEVs. The strategies published till 2012 are reviewed and categorized here. A detailed overview of different existing control strategies along with their merits and demerits is presented. A broad classification of these strategies is given in Figure 3. All these strategies are compared in terms of structural complexity, computation time, type of solution (real, global, and local), and a priori knowledge of driving pattern.

There is no commonly accepted answer for "structural complexity" but the intersection of almost all answers is

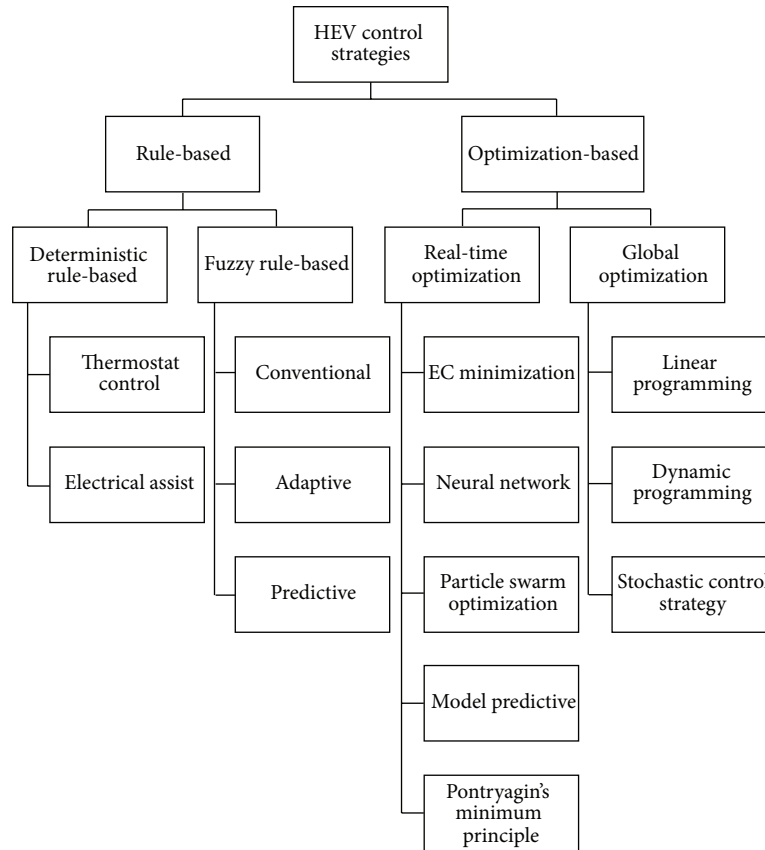

FIGURE 3: Classification of control strategies.

nonempty. Structural complexity deals with the complexity classes, internal structure of complexity classes, and relations between different complexity classes. Complexity class is a set of problems of related source-based complexity and can be characterized in terms of mathematical logic needed to express them. Computation time is the length of time required to perform a computational process.

A controller designed for a particular set of parameters is said to be robust if it performs fairly well under a different set of assumptions. To deal with uncertainty, robust controllers are designed to function properly with uncertain parameter set or disturbance set.

Local optimal of an optimization problem is optimal (either maximal or minimal) within a neighboring set of solutions. A global optimal, in contrast to local, is the optimal solution amongst all possible solutions of an optimization problem.

Control strategies are broadly classified into rule-based and optimization-based control strategy and all other subcategories are classified based on these two main categories.

5.1. Rule-Based Control Strategies. Rule-based control strategies are fundamental control schemes that depend on mode of operation. They can be easily implemented with real-time supervisory control to manage the power flow in a hybrid

drive train. The rules are determined based on human intelligence, heuristics, or mathematical models and generally without prior knowledge of a drive cycle.

The rule-based controllers are static controllers. Basically, the operating point of the components (ICE, traction motor, and generator, etc.) is chosen using rule tables or flowcharts to meet the requirements of the driver and other components (electrical loads and battery) in the most efficient way. The decisions are related to instantaneous inputs only. This strategy is further subcategorized into deterministic rule-based and fuzzy rule-based.

By recognizing the road load, an energy management system for belt driven starter generator (BSG) type hybrid vehicle is developed by Shaohua et al. [7]. It gives a good fuel economy as well as launch performance. The dynamic performance and drivability are also improved at the same time. For energy and power management of multisource (battery and super-capacitor) hybrid vehicles, a two-level management scheme is formulated. First level uses a certain set of rules to restrict the search area and second level uses a metaheuristic approach. Trovão et al. [8] provide a quality solution for sharing energy online between the two energy sources with improved range and extended battery life.

5.1.1. Deterministic Rule-Based Control Strategy. The rules are designed with the aid of fuel economy or emission data,

ICE operating maps, power flow within the drive train, and driving experience. Implementation of rules is performed via lookup tables to share the power demand between the ICE and the electric traction motor. Kim et al. [9] proposed a concept of hybrid optimal operation line for parallel HEV, which is derived based on effective specific fuel consumption with continuously varying transmission (CVT). They determined the optimal values of parameters (such as a CVT gear ratio, motor torque, and engine throttle) while maximizing overall system efficiency. For the optimal robust control, [10] developed a rule-based control algorithm and tuned it for different work cycles.

Thermostat control strategy uses the generator and ICE to generate electrical energy used by the vehicle. In this strategy the battery SOC is always maintained between predefined high and low levels, by simply turning on/off the ICE. Although the strategy is simple, it is unable to supply necessary power demand in all operating modes.

Electric assist control strategy utilizes ICE as the main source of power supply and electric motor to supply additional power when demanded by the vehicle. Due to charge sustaining operation, the battery SOC is maintained during all operating modes.

5.1.2. Fuzzy Rule-Based Control Strategy. L. A. Zadeh introduced the term fuzzy logic and described the mathematics of fuzzy set theory. Fuzzy logic system is unique to handle numerical data and linguistic knowledge simultaneously. Fuzzy sets represent linguistic labels or term sets such as slow, fast, low, medium, high, and so forth. In fuzzy logic, the truth of any statement is a matter of degree. Fuzzy control is simple, easy to realize, and has strong robustness. It can converse experience of designer to control rules directly. Fuzzy logic is a form of multivalued logic derived from fuzzy set theory to deal with reasoning that is approximate rather than precise.

Intelligent control is performed using fuzzy logic as a tool. Fuzzy logic enables the development of rule-based behavior. The knowledge of an expert can be coded in the form of a rule base and used in decision making. The main advantage of fuzzy logic is that it can be tuned and adapted if necessary, thus enhancing the degree of freedom of control. It is also a nonlinear structure and is especially useful in a complex system such as an advanced power train. In essence a fuzzy logic controller (FLC) is a natural extension of many rules based controllers implemented (via lookup tables) in many vehicles today. Fuzzy logic based methods are insensitive to model uncertainties and are robust against the measurement of noises and disturbances but require a faster microcontroller with larger memory.

(a) Traditional Fuzzy Control Strategy. Efficiency is decided based on the selection of input, output, and rule-based control strategy. Two operating modes, namely, optimize fuel use and fuzzy efficiency modes, are used to control drive train operation. The fuzzy logic controller accepts battery SOC and the desired ICE torque as inputs. Based on these inputs as well as the selected mode, the ICE operating point is set. The power required by the electric traction motor is the difference of total load power required and power required from ICE.

In the optimum fuel use strategy, the FLC limits instantaneous fuel consumption, calculated from the fuel use map, and maintains sufficient battery SOC, while delivering demanded torque. In the fuzzy efficiency strategy, the ICE has operated in its most efficient operating region. The operating points of the ICE are set near the torque region, where efficiency is highest at a particular engine speed. Load balancing is achieved using electric motors. This control strategy uses a motor to force ICE to operate in the region of minimal fuel consumption, while maintaining SOC in battery. Load balancing is necessary to meet power demand and avoid unnecessary charging and discharging of the electrical storage system (ESS). A major drawback of this control strategy is that the peak efficiency points are near high torque region; thereby ICE generates more torque than required, which in turn increases fuel consumption. Also, during load balancing, heavy regeneration overcharges the ESS. To avoid this, the control strategy should be used with a downsized ICE.

(b) Adaptive Fuzzy Control Strategy. This strategy can optimize both fuel efficiency and emissions simultaneously. However, fuel economy and emissions are conflicting objectives, which means that an optimal solution cannot be achieved by satisfying all the objectives. The optimal operating point can be obtained using weighted-sum approach optimization of conflicting objectives. Due to various driving conditions, appropriate weights have to be tuned for fuel economy and emissions. Considering stringent air pollution laws, operating points with high emissions are heavily penalized. The conflicting objectives within the adaptive fuzzy logic controller include fuel economy, NO_x , CO, and HC emissions. In order to measure the interrelationship of the four contending optimizing objectives with a uniform standard, it is essential to normalize the values of fuel economy and emissions by utilizing the optimal values of fuel consumption and emissions at current speed. The optimal values of fuel economy and emissions at particular ICE speed can be obtained from the ICE data map.

The relative weights are adaptively assigned to each parameter based on their importance in different driving environments. Moreover, weights must be selected for each ICE, based on their individual data maps. This control strategy is able to control any one of the objectives, by changing the values of relative weights. Further, tremendous reduction in vehicle emission is achieved, with negligible compromise in fuel economy.

(c) Predictive Fuzzy Control Strategy. If the information on the driving trip is a priori known, it is extremely trivial to obtain a global optimum solution, to minimize fuel consumption and emissions. However, the primary obstacles entail acquiring further information on planned driving routes and performing real-time control. This problem can be resolved using global positioning system (GPS) which can easily identify the probable obstacles like heavy traffic or a steep grade. The control strategies can be developed for specific situations; for example, if a vehicle is running on a highway and will enter into a city (where heavy traffic may be encountered), it is advised to restore more energy by charging the batteries, for

later use. General inputs to the predictive FLC are vehicle speed variations, the speed state of the vehicle in a look-ahead window, and elevation of sampled points along a predetermined route. Based on the available history of vehicle motion and its variability in the near future, FLC determines the optimal torque that ICE contributes to the current vehicle speed. The predictive FLC outputs a normalized GPS signal in $(-1, +1)$, which informs the master controller to charge or discharge the batteries and to restore enough energy for future vehicle operating modes.

Being robust and fast, it is advised to design FLCs for nonlinear and uncertain systems. FLCs result in small overshoot, short adjustment time, and good dynamic/static quality. Using mix-modelling approach, Arsie et al. [11] implement an FLC to control the parameters related to the driver-vehicle interaction, torque management, and battery recharging strategy. To improve energy conversion efficiency, several fuzzy logic based energy management strategies are implemented [12–14]. Galichet and Foulloy [15] implement a fuzzy logic based proportional integral (PI) controller for nonlinear control of the plants. Lee et al. [16] introduce an FLC for driving strategy implementation. This is useful for nonlinear and uncertain systems and is not affected by vehicle load variation and road pattern. Brahma et al. [17] design an HEV modelling tool using FLC to optimize the fuel consumption which may be used to implement any desired model. Baumann et al. [18] demonstrate the effectiveness of FLC to increase the fuel economy and show that it works well for a nonlinear, multidomain, and time-varying plant. Tao and Taur [19] design a less complex PID-like FLC with a heuristic functional scaling which is easy to adjust even in the absence of the plant's complete mathematical model. Won and Langari [20] design an FLC for torque distribution. Schouten et al. [21] apply driver command, battery SOC, and motor/generator speed as fuzzy sets to design an FLC for parallel HEVs. Patel and Mohan [22] design a very simple PI controller using fuzzy logic with less number of universes of discourse. Intelligent energy management agent (IEMA) is implemented for torque distribution and charge sustenance on the basis of current vehicle state, driver demand, and available online drive cycle data [23]. Bathaee et al. [24] implement a FL based torque controlled optimal energy management strategy for parallel HEV. Zeng and Huang [25] and Khoucha et al. [26] design (1) SOC based and (2) desired torque based FLCs for parallel HEV to optimize power split. Jianlong et al. [27] propose an effective, fast, and compact fuzzy supervisory controller with double input single output. Golkar and Hajizadeh [28] implement fuzzy logic based real-time intelligent controllers which optimally settle ICE torque and vehicle drivability with reduced fuel consumption and emissions. Syed et al. [29] implement a dynamic model of HEV, which is capable of analyzing the steady state and transient behavior of vehicle under different driving situations. Poursamad and Montazeri [30] introduce a genetic algorithm tuned FLC to minimize the fuel consumption and emissions and to improve the driving performance of a parallel HEV. Liu et al. [31] propose a battery SOC and power notification based FLC for series HEV. In this method, a high level of energy is always maintained and the engine works in the high efficiency region. Syed et al. [32]

design an FLC to intelligently control the engine power and speed in an HEV. In this scheme, the required gain of PI controller is decided by fuzzy gain scheduling based on system's operating conditions. It improves the response and settling time and eliminates overshoots. Zhou et al. [33] devise an FLC for torque demand and battery SOC (as input) and required torque (as output) based on particle swarm optimization (PSO) for energy management in a parallel HEV. To improve its accuracy, adaptability, and robustness, a compressibility factor was used with PSO. Won and Langari [34] propose an intelligent energy management strategy, based on the concept of driving situation awareness for parallel HEV. The authors basically implemented an IEMA which gives knowledge about driving situation awareness. Lu et al. [35] implement FLC for torque distribution between engine and motor in a PHEV. They simulated the controller using ADVISOR for the different driving/road conditions and showed a significant reduction in exhaust gases and improvement in fuel economy. Kachroudi et al. [36] design a predictive decision support system for optimal energy flow distribution among engine and other auxiliaries. They determined the global optimum using PSO, which was further validated using hardware-in-loop (HIL) technique. Fu et al. [37] designed a fuzzy control, energy management strategy, using ADVISOR and claimed improvement in the fuel economy with a reduction in the toxic emissions.

5.2. Optimization-Based Control Strategy. In optimization-based control strategies, the goal of a controller is to minimize the cost function. The cost function (objective function) for an HEV may include the emission, fuel consumption, and torque depending on the application. Global optimum solutions can be obtained by performing optimization over a fixed DC. These control techniques do not result in real-time energy management directly, but, based on an instantaneous cost function, a real-time control strategy can be obtained. This instantaneous cost function relies on the system variables at the current time only. It should include equivalent fuel consumption to guarantee self-sustainability of electrical path. Optimization-based control strategies can be divided into two main groups, namely, global optimization and real-time optimization. These are discussed in the following sections in detail.

5.2.1. Global Optimization. A global optimization technique for energy management strategy in an HEV requires the knowledge of entire driving pattern which includes battery SOC, driving conditions, driver response, and the route. Due to computational complexity, they are not easily implementable for real-time applications. Linear programming, dynamic programming, genetic algorithms, and so forth are used here to resolve vehicle energy management issues. Based on optimal control theory and assuming that minimizing the fuel consumption reduces the pollutant emissions, a global optimization algorithm is developed [38]. Delprat et al. [39] propose a global optimization strategy for HEVs performance analysis but do not provide optimal results. Delprat et al. [40] suggest a global optimization strategy for known driving cycle (DC) and for all SOC ranges. This offers

the quick global optimal solution and minimizes the fuel consumption. To get a better optimal solution for HEV design and control, another global optimization technique has been suggested by [41].

(1) *Linear Programming.* The fuel economy optimization is considered as a convex nonlinear optimization problem, which is finally approximated by linear programming method. Linear programming is mostly used for fuel efficiency optimization in series HEVs. Formulation of fuel efficiency optimization problem using linear programming may result in a global optimal solution.

In hybrid power trains, better degree of freedom to control exists. By controlling the gear ratio and torque, an optimized design and control of a series hybrid vehicle are proposed in [42]. The problem is formulated as a nonlinear convex optimization problem and approximated as a linear programming problem to find the fuel efficiency. Kleimaier and Schroeder [43] propose a convex optimization technique for analysis of propulsion capabilities using linear programming, which provides independence from any specific control law. Pisu et al. [44] design supervisory control strategies for hybrid electric drive trains to minimize fuel consumption. They designed a stable and robust controller using linear matrix inequalities. Miaohua and Houyu [45] design a sequential quadratic programming based energy management strategy to minimize fuel consumption. They consider balanced SOC as a constraint and showed improved results.

(2) *Dynamic Programming.* Dynamic programming (DP) was originally used in 1940 by Richard Bellman to describe the process of solving problems where one needs to find the best decisions successively. DP is both a mathematical optimization method and a computer programming method. In both contexts, it refers to simplifying a complicated problem by breaking it into simpler subproblems in a recursive manner.

The very essence of this technique is based on the principle of optimality. Having a dynamical process and the corresponding performance function, there are two ways to approach the optimal solution to the problem. One is the Pontryagin's maximum principle and the other is Bellman's dynamic programming. It has the advantage of being applicable to both linear and nonlinear systems as well as constrained and unconstrained problems. But it also suffers from a severe disadvantage called curse of dimensionality which amplifies the computational burden and limits its application to complicated systems.

Since the knowledge of the duty cycle is required beforehand, the DP algorithm cannot be implemented in real time. However, its outputs can be used to formulate and tune actual controllers. The power management strategy in an HEV is computed through dynamic optimization approach by various researchers as mentioned below.

Power optimization can be done offline for known DC using deterministic DP [46, 47]. An adaptive neural-fuzzy inference system (ANFIS) along with DP is used to get the optimal solution to the problem [48]. Using DP and a rule-based approach, optimal power split between both of energy sources is obtained for a series HEV [49]. They suggest

that to increase computational efficiency, the discrete state formulation approach of DP should be used. To reduce the fuel consumption, a DP based optimal control strategy for a parallel hybrid electric truck is reported in [50]. They developed a feedforward, parallel HEV simulator in order to maximize fuel efficiency and proposed DP and rule-based power optimization algorithm for sustaining mode of battery operation. Sundstrom et al. [51] study the hybridization ratio of two types of parallel HEVs, namely, (1) torque assist and (2) full hybrid. Further, using DP optimal fuel consumption is achieved for different hybridization ratios. The results show that both fuel consumption and need of hybridization are less in case of the full hybrid model. A medium-duty hybrid electric truck is implemented using DP [52] to optimize the power and fuel economy. It results in 45% higher fuel economy than ICE truck. A near optimal power management strategy is obtained using DP, considering sustained SOC as a constraint. Koot et al. [53] proposed an energy management strategy for HEVs and verified it through DP, quadratic programming, and modified DP (DPI) strategies. DP takes large time as number of computation increases with the DC length. To reduce the computation time for longer DCs, quadratic programming is used which also promises global solution. In DPI, the complete DC is divided into various segments and DP is implemented in incremented steps for entire DC. DPI is preferred over DP and quadratic programming as it does not require future knowledge of DC and exploits nonconvexity of cost function. Further, it is easy to implement online. Electric vehicle centric and engine-motor blended control strategies which are applicable to PHEVs using DP to get an optimal power split are explored by [54]. They concluded that, for urban driving pattern, electric vehicle centric control strategy provides better fuel economy over others. To keep energy levels in a prescribed range without affecting the battery health in HEVs, [55] formulated a finite horizon dynamical optimization problem and solved it using DP. Gong et al. [56] implement a power optimization strategy using DP for PHEVs in charge depletion mode. For global optimization of charge depletion control of PHEVs, two-scale DP approach is adapted which results in reduction of fuel consumption by 3.7% compared to conventional DP. Van Keulen et al. [57] solve an energy management problem for HEVs and optimize it using DP in charge sustaining mode. Gong et al. [58] use an efficient on-board implementable two-scale DP for PHEVs to get a global optimal solution. Electric mode of operation is used first for known trip distance. The rest of the distance is divided into different segments of known length and for each segment fuel consumption and SOC level are calculated. Finally, spatial domain optimization is performed to find the solution. Sundström and Guzzella [59] propose a generic DP function, to solve discrete time optimal control problem using Bellman's DP algorithm. The authors in [60, 61] use DP and on-board implementable energy consumption minimization strategy (ECMS) for charge depletion mode operation. They conclude that, for long distances and large size batteries, ECMS and DP provide a similar fuel economy and SOC profile. Shen and Chaoying [62] used an improved DP to solve optimal control problem to reduce computation time using a forward search algorithm. Along with DP,

classical optimal control theory is applied to reduce the fuel consumption in parallel HEVs for a known route profile. This results in an improvement of 11% in fuel economy as compared to standard city drive cycle [63]. Kum et al. [64] firstly found an optimal solution using DP and estimate battery SOC with respect to remaining trip distance using energy-to-distance ratio (EDR). Then they implement an adaptive supervisory power train controller (SPC) to reduce fuel consumption and emissions based on extracted results from EDR and catalyst temperature system. For a multisource HEV containing gen set, [65] proposed a DP for optimizing power management system. In case of known trip distance it can give global optimal solution and save 12.6% gasoline. Li and Kar [66] use DP to design a power split device (PSD) in PHEVs, which minimizes the fuel consumption and enhances the vehicle performance. Ravey et al. [67] initially propose a method to minimize the size of the components (energy source) using genetic algorithm. Later they use DP to optimize the power management strategy and claim a higher fuel economy. Shams-Zahraei et al. [68] implement an optimal energy management strategy using DP considering the significance of temperature noise factors. With the variation in temperature, fuel efficiency, and emissions, energy management system changes even for the same driving patterns and conditions.

(3) *Stochastic Control Strategy.* Stochastic strategy is a framework for modelling, optimization problems that involve uncertainty. In this strategy, an infinite-horizon stochastic dynamic optimization problem is formulated. The power demand from the driver is modelled as a random Markov process. The Markov driver model predicts the future power demands by generating the probability distribution for them. The past decisions are not required for this prediction. The optimal control strategy is then obtained using stochastic dynamic programming (SDP). The obtained control law is in the form of a stationary full-state feedback and can be directly implemented. It is found that the obtained SDP control algorithm outperforms a suboptimal rule-based control strategy trained from deterministic DP results. As opposed to deterministic optimization over a given DC, the stochastic approach optimizes the control policy over a family of diverse driving patterns.

(a) *Stochastic Dynamic Programming.* Optimization method which uses random variables to formulate an optimization problem is called stochastic optimization. In dynamic programming if either state or decision is known in terms of probability function, it is called stochastic dynamic programming (SDP). A high performance computing technique is required to solve the stochastic optimal control problem.

For better optimality in comparison to supervisory control strategy, [69] proposes an infinite-horizon SDP in which power demand by the driver is modelled as a random Markov process. The control law obtained is real-time implementable in HEVs. In a parallel hybrid electric truck, both infinite-horizon SDP and shortest path SDP (SP-SDP) optimization problems are formulated which yield a time-invariant causal state-feedback controller. In SP-SDP power management

strategy variation of battery SOC from a desired set-point is allowed to get a trade-off between fuel consumption and emissions. The SP-SDP based controller is advantageous over SDP as it offers better SOC control and less number of parameters to be tuned [70]. Using SDP, [71] formulated a hybrid power optimal control strategy using engine-in-loop (EIL) setup, which instantly analyzes the effect of transients on engine emissions. Tate et al. [72] used the SP-SDP to find a trade-off between fuel consumption and tailpipe emissions for an HEV, facilitated with a dual mode EVT. With simple methods SP-SDP solution takes eight thousand hours while using linear programming and duality it takes only three hours. Moura et al. [73] presented a power optimization strategy for PHEVs using SDP to optimize the power split between ICE and electric motor for a number of DCs. At the same time, authors proposed a trade-off for electricity and liquid fuel usage and also analyzed the relative fuel and electricity price variation for optimal performance. Using SP-SDP, [74] proposes a real-time energy management controller. This considers drive cycle as a stationary-finite scale Markov process. This controller is found to be 11% more efficient than an industrial baseline controller. Wang and Sun [75] propose an SDP-extremum seeking (SDP-ES) algorithm with state-feedback control. It contains the nature of global optimality of SDP and SOC sustainability. Further extremum seeking output feedback compensates for its optimal control error. Opila et al. [76] develop an energy management strategy based on SDP and implemented successfully in a prototype HEV. The feature of this controller is that they run in real-time embedded hardware with classic automotive computing ability and the energy management strategy gets updated very frequently to yield a strong driving characteristic.

(b) *Genetic Algorithm.* Genetic algorithm (GA) is a heuristic search algorithm to generate the solution to optimization and search problems. Thus a branch of artificial intelligence is inspired by Darwin's theory of evolution. GA begins with a set of solutions (chromosomes) called a population. The solutions from one population are taken according to their fitness to form new ones. Most suitable solutions will get a better chance than the poorer solutions to grow and the process is repeated until the desired condition is satisfied. GA is a robust and feasible approach with a wide range of search space and rapidly optimizes the parameters using simple operations. They are proven to be effective to solve complex engineering optimization problems, characterized by nonlinear, multimodal, nonconvex objective functions. GA is efficient at searching the global optima, without getting stuck in local optima.

Unlike the conventional gradient based method, GA technique does not require any strong assumption or additional information about objective parameters. GA can also explore the solution space very efficiently. However, this method is very time consuming and does not provide a broader view to the designer.

Piccolo et al. [77] utilize GA for energy management of an on-road vehicle and minimize the cost function containing fuel consumption and emission terms. For dynamic and unpredictable driving situations, a fuzzy clustering criterion

is used with GA which reduces the computational effort and improves the fuel economy [78]. GA in HEVs is used simultaneously to optimize the component sizes and to minimize the fuel consumption and emissions [79–84]. Wang and Yang [85] implement a robust, easy, and real-time implementable FL based energy management strategy and use the GA to tune and optimize the same. To optimize the fuel consumption and emissions in a series HEV, GA based control strategy has been used by [86]. It is a flexible and global optimal multiobjective control strategy which is found to be better than thermostatic and divide rectangle (DIRECT) algorithm. Reference [87] uses multiobjective genetic algorithm (MOGA) to solve an optimization problem for series HEV. Control strategy based on MOGA is flexible, multiobjective and gives global optimal. A MOGA is further used by [88, 89] to solve the optimization problem of HEVs which optimizes control system and power train parameters simultaneously and yields a Pareto-optimal solution. Montazeri-Gh et al. [90] present a genetic-fuzzy approach and find an optimal region for the engine to work. It provides an optimal solution to the optimization problem. Wimalendra et al. [91] applied GA to parallel HEV to find the optimal power split for improved vehicle performance and also promise to give maximum fuel economy for known DC for a parallel HEV using GA. References [30, 92] implemented fuzzy control strategy for reduced fuel consumption and emissions which is optimized by GA. MOGA is developed to reduce fuel consumption and emissions as well as to optimize power train component sizing [93]. Using non-dominated sorting genetic algorithm (NSGA), a Pareto-optimal solution is obtained for reduced component sizing, fuel consumption, and emissions [94].

A genetic algorithm is a powerful optimization tool which is particularly appropriate to multiobjective optimization. The ability to sample trade-off surfaces in a global, efficient, and directed way is very important for the extra knowledge it provides. In the case where there are two or more equivalent optima, the GA is known to drift towards one of them in a long term perspective. This phenomenon of genetic drift has been well observed in nature and is due to the populations being finite. It becomes more and more important as the populations get smaller. NSGA varies from GA only in the way the selection operator works. Crossover and mutation operations remain the same. This is similar to the simple GA except the classification of nondominated fronts and sharing operations. MOGA is a modification of GA at selection level. MOGA may not be able to find the multiple solutions in case where different Pareto-optimal points correspond to the same objective.

5.2.2. Real-Time Optimization. Due to the causal nature of global optimization techniques, they are not suitable for real-time analysis. Therefore, global criterion is reduced to an instantaneous optimization, by introducing a cost function that depends only on the present state of the system parameters. Global optimization techniques do not consider variations of battery SOC in the problem. Hence, a real-time optimization is performed for power split while maintaining the battery charge.

Instantaneous optimization techniques based on simplified model and/or efficiency maps are proposed in [95, 96]. Reference [95] presents the concept of real-time control strategy for efficiency and emission optimization of a parallel HEV. It considers all engine-motor torque pairs which forecast the energy consumption and emissions for every given point. Reference [96] developed a control strategy for parallel hybrid vehicle in a charge sustaining mode of operation for instantaneous fuel efficiency optimization. And to implement the global constraint, the authors developed a nonlinear penalty function in terms of battery SOC deviation from its desired value.

(1) *Equivalent Consumption Minimization Strategy.* Paganelli et al. propose the concept of equivalent fuel consumption for energy management strategy. It reduces a global optimization problem into an instantaneous minimization problem and provides solution at each instant. Energy consumption minimization strategy (ECMS) calculates the fuel equivalent as a function of current system status and quantities measurable on board, online. It does not require prior knowledge of driving pattern to get an optimal solution and it is real-time implementable.

ECMS is developed by calculating the total fuel consumption as sum of real fuel consumption by ICE and equivalent fuel consumption of electric motor. This allows a unified representation of both, the energy used in the battery and the ICE fuel consumption. Using this approach, equivalent fuel consumption is calculated on a real-time basis, as a function of the current system measured parameters. No future predictions are necessary and only a few control parameters are required. These parameters may vary from one HEV topology to another as a function of the driving conditions. ECMS can compensate the effect of uncertainties of dynamic programming. The only disadvantage of this strategy is that it does not guarantee charge sustainability of the plant.

Equivalent fuel consumption is calculated based on the assumption that SOC variation in the future is compensated by the engine running at current operating point. Jalil et al. [97] use thermostatic control strategy to turn the engine on/off based on SOC profile but did not yield optimal results. Paganelli et al. [96] implement an ECMS for a hybrid electric sport utility vehicle in charge sustaining mode, to minimize the fuel consumption and pollutant emission. This instantaneous minimization results in reducing the toxic emissions without degrading the fuel economy. Paganelli et al. [98] implement an ECMS for PHEVs, which gives an instantaneous power split strategy in charge sustaining mode. Paganelli et al. [99] implement an ECMS to minimize fuel consumption of HEV by splitting the power between ICE and electric motor. They achieve a reduction in the fuel consumption by 17.5% as compared to ICE based vehicle alone. This result is also verified using global optimization theory as utilized in [38]. Supina and Awad [100] suggest turning on/off the engine according to the battery energy level and thus this results in improved fuel efficiency of 1.6% to 5% over the thermostat control. Without the knowledge of future driving conditions to find the real-time control of fuel consumption of parallel HV is presented in [101]. It uses ECMS

for the instantaneous optimization of the cost function and it depends only upon the current system operation. Won et al. [102] propose an energy management strategy for torque distribution and charge sustenance of HEV using ECMS. In this, a multiobjective torque distribution strategy is formulated first and then it is converted into single objective linear optimization problem. References [103, 104] implement a modified ECMS for a series HV configuration with two different energy sources which is a generalization of instantaneous ECMS proposed in [98, 99]. For real-time energy management, [105, 106] propose an adaptive equivalent consumption minimization strategy (A-ECMS). It continuously updates the control parameter according to road load condition and provides a quasi-static solution for supervisory control in comparison to ECMS and rule-based strategy. Salmasi [107] designs a novel control strategy for series HEV, which does not require any model of vehicle device and consumes less computation time. Sciarretta and Guzzella [108] analyze that ECMS is a close optimal solution for PHEV energy management. An ECMS, which is an instantaneous optimization strategy, is implemented in a series city hybrid bus. These buses have different power train configurations like fuel cell and battery or diesel engine and battery [109]. Using ECMS, [110, 111] present real time implementable control strategy which even in the absence of future driving information supplies optimal results for fuel consumption minimization and toxic emission reduction. Tulpule et al. [112] propose an ECMS, which requires knowledge of total trip distance instead of driving pattern information to improve fuel economy. Marano et al. [113] compared ECMS and DP for the comparison of optimal performance of PHEVs and concluded ECMS as an on-board implementable control strategy. He et al. [114] present an A-ECMS for power-split PHEVs using predictive speed profiles. During the whole journey optimization, window sizes are identified which result in improvement in fuel consumption. The fuel consumption ratio varies with DC chosen and operating modes. Cui et al. [115] develop an energy management strategy which comprises two stages: (1) instantaneous optimization using ECMS and (2) global parameter estimation using DP. Knowledge of distance of the next charging station during travel gives a noteworthy fuel economy and full knowledge of terrain preview gives almost 1% of fuel economy improvement.

(2) *Model Predictive Control (MPC)*. Model predictive control (MPC) is a good method for dynamic model of the process which is obtained by system identification. The main feature of the MPC is to allow current timeslot to be optimized taking future timeslots into account. This is achieved by optimizing a finite time-horizon and implementing the current timeslot only. MPC can anticipate future events and can take control actions accordingly.

Using MPC, West et al. [116] enhance the battery lifetime and vehicle driving range and at the same time reduce the toxic emissions and drive train oscillations for EVs and HEVs. Model based strategy for real-time control of parallel hybrid without knowing future driving conditions is proposed by [101]. Real-time implementable energy management strategy of an HEV using MPC is presented in [117, 118].

Reference [117] uses mixed integer linear programming to envisage the best control. They state that the predictive optimal control offers superior fuel economy compared to that of instantaneous strategies. In classical model predictive control, at each step an online optimization problem is required to solve. To address this, an MPC with improved speed is implemented by [119]. Mahapatra [120] formulates a model based design for HEVs with an idea to reuse this design at various development stages. It also benefits in the form of lower cost and time saving. Kermani et al. [121] implement a Lagrange formula based global optimization algorithm using MPC. An energy management strategy for a series HEV is proposed by [122] using MPC and quadratic programming. Using a quasi-static simulator developed in the MATLAB environment, MPC algorithm is applied. They also investigate the length and type of predictions. Ripaccioli et al. [123] describe a hybrid MPC strategy to coordinate power train subsystem and to enforce state and control constraints. Firstly, authors develop a hybrid dynamical model using linear and piecewise affine identification method and then design an MPC to reduce emissions. Borhan et al. [124] develop a nonlinear MPC for HEVs to solve the power-split optimization problem online. In the absence of a priori knowledge of driving pattern, [125] presented a stochastic-model predictive control for power management of series HEV. Power demand from the driver is modelled as a Markov chain. This algorithm optimizes over a distribution of future requested power demand from the current demand at each sample time. Vogal et al. [126] use a predictive model to improve fuel efficiency. The authors utilize a probabilistic driving route prediction system and train it using inverse reinforcement learning. Borhan et al. [127] propose an MPC based minimum fuel consumption strategy for power-split hybrid vehicles. The complex energy management problem is divided into two levels. For the first level (supervisory level) MPC is used to calculate future control sequences that minimize a performance index and then is applied to the first element of the computed control sequence of the hybrid vehicle model. For a parallel HEV, an MPC torque-split strategy is developed [128] considering the effect of the diesel engine transient characteristic. The authors conclude that the MPC based method can improve the fuel economy. For minimization of fuel consumption and to keep the SOC within a specified range, [129] presented an MPC based controller, which works on torque demand predictions estimated from the desired SOC and desired vehicle speed. Cui et al. [115] proposed an online receding controller, which works on the principle of predictive control for parallel HEVs. The energy management strategy based on this predictive control gives the fuel economy of 31.6% compared to rule-based control. This shows the potential of predictive control. The authors conclude that predictive control strategies utilize battery power more effectively and hence give better fuel efficiency and reduced emissions compared to the rule-based.

(3) *Neural Networks*. McCulloch and Pitts in 1943 firstly designed the neural network and Hebb in 1949 developed the first learning rule. Artificial neural network (ANN) is a network of artificial neurons and is a parallel computation

technique consisting of many processing blocks connected together in a specific way to perform a specific task. ANN is a powerful computational method which learns and generalizes from training data. This uses the principle of function approximation. The output of a neuron is a function of the weighted sum of the inputs and a bias. The function of the entire neural network is simply the computation of the outputs of all the neurons.

NN's adaptive structure makes it suitable for any control applications. A well designed network can get fit to any lookup table and can adapt itself by training to update the table data. This feature makes it better than rule-based controllers. Recurrent NNs are networked with dynamic feedback which means they can also be modelled as dynamic controller. NN is an effective approach for pattern recognition and function fitting.

Baumann et al. [130] used ANN and fuzzy logic for implementing a load leveling strategy and implemented a supervisory controller, which takes care of fuel economy and reduced emissions in case of different drivers and driving pattern. For analysis and control of power split in a parallel HEV, Arsie et al. [131] modelled a dynamic system with vehicle-driver interaction, ICE, and electric motor/generator. Using this, vehicle load estimation is performed using NN to optimize the supervisory control strategy for the optimized performance of the vehicle. Mohebbi et al. [132] presented a neuro-fuzzy controller, which is implemented using ANFIS method. This controller is designed based on (1) torque required for driving and (2) battery SOC; and it maximizes the driving torque and minimizes the fuel consumption. Prokhorov [133] proposed NN controller for Toyota Prius HEV based on recurrent NN using online and offline training, including extended Kalman filtering and simultaneous perturbation stochastic approximation. Author claimed better results by combining online and offline methods. For the nonlinear control system, Liu [134] implemented a high accuracy fuzzy neural network (FNN) controller. The membership function of FNN is optimized using modified genetic algorithm and error-compensation method and results are found better than the normal FLC. Suzuki et al. [135] designed a hybrid controller for HEVs to optimize torque distribution, liquid fuel, and electric current consumption during vehicle propulsion using NN with online simulation. Gong et al. [136] derived a NN based improved trip model for driving pattern of PHEVs; hence an increased fuel economy is achieved. In lack of a priori information about driving pattern, a real-time controller using neurodynamic programming is proposed by [137] which gives optimal power split for parallel hybrid electric light commercial vehicle. Murphey et al. [138] used NN to predict road and traffic conditions optimal power split in HEVs. The authors first developed a machine-learning framework for energy optimization in an HEV; then they present three online intelligent energy controllers: (1) IEC_HEV_SISE; (2) IEC_HEV_MISE; and (3) IEC_HEV_MIME. The three online controllers were integrated into the Ford Escape hybrid vehicle model for online performance evaluation. All three online intelligent energy controllers were trained within the machine-learning framework to generate the best combination of engine power and

battery power to minimise the total fuel consumption. The performance of IEC_HEV_MISE controller was found best and led to fuel savings ranging from 5% to 19% as compared to default Ford Escape controller.

(4) *Particle Swarm Optimization*. Particle swarm optimization (PSO) is a faster, inexpensive, robust stochastic global optimization technique developed by Eberhart and Kennedy in 1995. This technique is used for continuous nonlinear function and was developed based on the swarm in nature as bird [139, 140]. PSO is a heuristic evolutionary search algorithm which is an iterative optimization method using particles (population of candidate solutions) and moving these particles around in the search space according to a mathematical formula over the particle's position and velocity. In PSO, particles move around a search space and are guided by best known positions in the search space as well as entire swarm's best known position. When improved positions are discovered, these will guide the movements of the swarm particles. The process is repeated but does not guarantee the satisfactory solution.

PSO is a metaheuristic approach as it makes few or no assumptions about the problem being optimized and can search very large spaces of candidate solutions. However, metaheuristics such as PSO do not guarantee an optimal solution. More specifically, PSO does not use the gradient of the problem being optimized, which means PSO does not require the optimization problem to be differentiable as is required by classical optimization methods, such as gradient descent and quasi-Newton methods. PSO can therefore also be used on optimization problems that are partially irregular and noisy, change over time, and so forth.

The multilevel hierarchical control strategy optimized by the improved PSO algorithm can properly determine the direction and quantity of the energy flow in the HEVs/PHEVs and make the main power train components operate at high efficiency so that the fuel consumption can be reduced.

For parallel HEV, a multilevel hierarchical control strategy is proposed by [141, 142] using MATLAB/Simulink/Stateflow and optimized using PSO to get an optimal energy flow between engine and electric motor. Wang et al. [143] proposed a power control strategy to optimize fuel consumption and emissions in HEVs using PSO and it is compared with DIRECT algorithm. By simulating these strategies for several DCs, PSO is found to be better than DIRECT. Wu et al. [144] implemented an FLC for energy management system. Membership function and the rules of FLC are optimized by using PSO to find improved fuel economy and decreased emissions in HEVs. For a charge sustaining operation this strategy gives better fuel efficiency. Al-Aawar et al. [145] combined PSO and electromagnetic-team fuzzy logic (EM-TFL) together for the design optimization of the HEV power train system to find best electromechanical component sizes for higher efficiency and reduced fuel consumption. Desai and Williamson [146] optimized both power train and control strategy (objective function and constrained function) parameters using PSO for improved fuel economy and efficiency and reduced emissions. Hegazy and Van Mierlo [147] conclude that PSO consumes less time than GA to obtain

a solution and is easier to implement. Varesi and Radan [148] used PSO to find the optimal degree of hybridization in series-parallel HEV using advance vehicle simulator (ADVISOR) to optimize the vehicle performance with reduced fuel consumption and emissions. To optimize the various components of HEV, EM-TFL with PSO has been used by [149] in the form of a case study which concludes that a smaller size engine, electric motor performance, is optimized and fuel economy is improved by 22% and reduction in toxic emissions is noticed. Junhong [150] proposed PSO for energy optimization in PHEVs using MATLAB/Simulink and showed an improvement in fuel economy and reduction in pollutant emissions. Su and Chow [151] optimized the capacity of a parking lot with five hundred PHEVs with objective function as “average SOC” and constraints as “remaining SOC,” “remaining charge time,” and “energy prices.” Wu et al. [152] optimized the component size and control strategy simultaneously in parallel HEVs. This proposed a self-adaptive PSO algorithm and uses applied fuzzy set theory to extract the best suitable solutions.

(5) *Pontryagin's Minimum Principle*. Pontryagin's minimum principle (PMP), formulated in 1956 by the Russian mathematician Lev Semenovich, gives the best possible control to take a dynamical system from one state to another state in the presence of constraints for some state or input control. PMP is a special case of Euler-Lagrange equation of calculus of variations. For an optimum solution, PMP provides only necessary conditions and the sufficient conditions are satisfied by Hamilton-Jacobi-Bellman equation. In PMP, the number of nonlinear second-order differential equations linearly increases with the dimension so the control based on PMP takes less computational time for getting an optimal trajectory but it could be a local optimal, not a global solution. Under certain assumptions optimal trajectory obtained by PMP should be considered as a global optimal trajectory. These are as follows: (1) trajectory obtained from PMP is unique and satisfies the necessary and boundary conditions, (2) some geometrical properties of the optimal field provide the possibility of optimality clarification, and (3) as a general statement of the second approach, the absolute optimality is, mathematically, proven by clear proposition [153].

Geering [154] explains PMP to reduce a global energy optimization problem into a local optimization problem. Ser-rao and Rizzoni [155] implement an optimal control strategy using PMP to get an optimal solution. They have converted global optimization problem into an instantaneous optimization problem. Kim et al. [156] applied PMP to find the optimal control law for PHEVs using instantaneous optimization. The available literature concludes that by proper selection of state constraints instantaneous optimization strategy results in near optimal solution as given by DP. A real-time controller can be obtained as this technique becomes very simple after selection of the state constraint. Stockar et al. [157] used PMP to build an optimal supervisory controller by reducing a global optimization problem into local. The advantage of this is that it reduces computational requirement and gives the freedom to solve the problem in the continuous time domain. Stockar et al. [158] proposed a model based control strategy

to minimize the CO₂ emission. A supervisory energy management strategy is implemented as a global optimization problem and then converted into local and using PMP, optimal energy utilization for PHEVs is obtained. For real-time implementation of an energy management strategy, the tools used by [159] consist of PMP based offline optimizer which results in ECMS and is implementable in real-time environment. A real-time optimal control can be obtained using PMP as it uses instantaneous minimization of the Hamiltonian function. Kim et al. [160] state that solution based on PMP can be a global optimal under some certain assumptions. Kim et al. [161] applied PMP based control strategies to the PHEVs and found that it gives a number of alternative solutions. They concluded the blended mode control results as the best strategy in term of battery usage and provide a near global optimal solution as can be obtained by DP. Kim et al. [162] find that PMP provides a near-optimal solution for optimal power management of HEVs if future driving conditions are known. It is suggested to find proper costate to keep SOC at a desired and predefined level.

As the trajectory derived from PMP might not be a global optimal solution, therefore, the control based on PMP can be considered as inferior to the DP. DP requires more computing time than PMP because DP solves all possible optimal controls to fill the optimal field. Since DP is a numerical representation of the HJB equation, it needs a similar computation load as the Hamilton-Jacobi-Bellman equation, which solves a partial differential equation. PMP solves just nonlinear second-order differential equations. The drawback of DP with regard to the computational load becomes compounded due to the “curse of dimensionality.”

6. Other Power Management Strategies

Power management methodology with CVT for HEVs is implemented to optimize the power [102, 163, 164]. Won et al. [102] give a power management strategy for charge sustenance mode and torque distribution in HEV. Ceraolo et al. [165] provide an energy flux based optimal energy consumption approach which helps out in solving the problems occurring at design stage. Khayyam et al. [166] provide an intelligent energy management model which considers the impact of rolling, drag, slope, and accessory loads. Under various driving conditions this model minimizes the fuel consumption. Amjad et al. [167] designed a microprocessor based energy management strategy for the optimal power split. Ji et al. [168] proposed a real-time energy management strategy for a CVT based parallel HEV to avoid charging of the battery directly through the engine. The energy recuperated during regenerative braking is distributed to achieve a dynamic converging characteristic. A charge blended energy management strategy named as equivalent fuel consumption method (EFCM) for PHEVs is presented by [169]. EFCM controller is associated with a proportion plus integral (PI) controller. For any type of drive cycle or any size of the battery, PI controller outputs time varying charge sustaining penalty function which controls battery SOC. Reference [170] suggested robust multivariable control systems better than existing torque management strategies. The proposed controller

TABLE I: Comparison chart for various control strategies.

Methods	Structural complexity	Computation time	Type of solution	Requirement of a priori knowledge
Fuzzy logic	N	S	G	Y
Genetic algorithm	Y	M	G	N
Particle swarm optimization	N	M	G	N
Energy consumption minimization strategy	Y	S	L	N
Pontryagin's minimum principle	N	S	L	Y
Dynamic programming	Y	M	G	Y
Model predictive	N	S	G	N
Stochastic dynamic programming	Y	M	G	N
Neural network	Y	S	G	Y

G = global, L = local, N = no, Y = yes, M = more, and S = small.

works on dynamic models of plant and considers the drivability requirements. It is also capable of posing the significant robustness in the presence of any type of uncertainties like change in dynamics of plant and nonavailability of vehicle load torque. Shahi et al. [171] proposed an approach for optimal PHEV hybridization using Pareto set pursuing (PSP) multiobjective optimization algorithm. The main feature of this algorithm is that it uses very less time (17 days) compared to exhaustive search approach (560 days) for PHEV 20 on urban dynamometer driving schedule (UDDS). Moreover the authors conclude that optimal hybridization scheme (battery, motor, and engine should work collectively for optimum performance) varies with DCs and AERs and strongly affects the fuel efficiency.

7. Conclusion and Future Direction

As HEVs are gaining more popularity, the role of the energy management system in the hybrid drive train is escalating. A thorough description and comparison of all the control strategies to optimize the power split between the primary and secondary sources of HEVs/PHEVs used are given here. Evolution of control strategies from thermostat to advanced intelligent methods is included in the study.

Rule-based controllers are easily implementable, but the resultant operation may be quite far from optimal; that is, the power consumption is not optimized for the whole trip. In order to achieve the global optimality a priori information of trip is required. Although real-time energy management is not directly possible using optimization-based methods, an instantaneous cost function based strategy may result in real-time optimization. The strategies discussed in this paper are real-time implementable and are robust in nature. Table I is the concluding table and serves as a guide to choose the correct method of optimization. It is suggested that strategies should take less computational time, provide global optimal results, and get fit to the dynamic simulation environment.

To obtain reduced liquid fuel consumption and larger electric operating range without compromising with the speed and performance of vehicle, a new technology, that is, a PHEV, is in practice globally. PHEVs' charge depletion mode of operation is desirable, but a blended mode of operation

may be a promising solution to extend operating electric range. The control strategies suggested so far are required to be explored more in context of operating specifications and their true potential for PHEVs.

Conflict of Interests

The authors declare that there is no conflict of interests regarding the publication of this paper.

Acknowledgment

The authors are grateful to Professor S. K. Choudhary, Department of Humanities and Social Sciences, B.I.T.S. Pilani, for giving his valuable time to improve the quality of paper grammatically.

References

- [1] M. Ehsani, Y. Gao, and J. M. Miller, "Hybrid electric vehicles: architecture and motor drives," *Proceedings of the IEEE*, vol. 95, no. 4, pp. 719–728, 2007.
- [2] M. Ehsani, Y. Gao, and A. Emadi, "Environmental impact and history of modern transportation," in *Modern Electric, Hybrid Electric and Fuel Cell Vehicles-Fundamentals, Theory and Design*, pp. 1–8, CRC Press, New York, NY, USA, 2nd edition, 2010.
- [3] K. Parks, P. Denholm, and T. Markel, "Costs and emissions associated with plug-in hybrid electric vehicle charging in the Xcel energy," Tech. Rep. NREL/TP-640-41410, Colorado Service Territory, National Renewable Energy Laboratory, Golden, Colo, USA, 2007, Contract No. DE-AC36-99-GO1033.
- [4] J. Kim, N. Kim, S. Hwang, Y. Hori, and H. Kim, "Motor control of input-split hybrid electric vehicles," *International Journal of Automotive Technology*, vol. 10, no. 6, pp. 733–742, 2009.
- [5] H. Yang, B. Kim, Y. Park, W. Lim, and S. Cha, "Analysis of planetary gear hybrid powertrain system part 2: output split system," *International Journal of Automotive Technology*, vol. 10, no. 3, pp. 381–390, 2009.
- [6] N. Kim, J. Kwon, and A. Rousseau, "Trade-off between multi-mode powertrain complexity and fuel consumption," in *Proceedings of the 25th World Battery, Hybrid and Fuel Cell Electric Vehicle Symposium & Exhibition*, Shenzhen, China, November 2010.

- [7] L. Shaohua, D. Changqing, Y. Fuwu, W. Jun, L. Zheng, and L. Yuan, "A rule-based energy management strategy for a new BSG hybrid electric vehicle," in *Proceedings of the 3rd Global Congress on Intelligent Systems*, pp. 209–212, November 2012.
- [8] J. P. Trovão, P. G. Pereirinha, H. M. Jorge, and C. H. Antunes, "A multi-level energy management system for multi-source electric vehicles—an integrated rule-based meta-heuristic approach," *Applied Energy*, vol. 105, pp. 304–318, 2013.
- [9] C. Kim, E. NamGoong, S. Lee, T. Kim, and H. Kim, "Fuel economy optimization for parallel hybrid vehicles with CVT," SAE Technical Paper 1999-01-1148, 1999.
- [10] M. Zaher and S. Cetinkunt, "Real-time energy management control for hybrid electric powertrains," *Journal of Control Science and Engineering*, vol. 2013, Article ID 801237, 10 pages, 2013.
- [11] I. Arsie, C. Pianese, G. Rizzo, and M. Santoro, "A model for the energy management in a parallel hybrid vehicle," in *Proceedings of the 3rd International Conference on Control and Diagnostics in Automotive Applications*, Paper No. 01A3037, Sestri Levante, Italy, July 2001.
- [12] S. D. Farrall and R. P. Jones, "Energy management in an automotive electric/heat engine hybrid powertrain using fuzzy decision making," in *Proceedings of the IEEE International Symposium on Intelligent Control*, pp. 463–468, Chicago, Ill, USA, August 1993.
- [13] E. Cerruto, A. Consoli, A. Raciti, and A. Testa, "Energy flows management in hybrid vehicles by fuzzy logic controller," in *Proceedings of the 7th Mediterranean Electrotechnical Conference*, vol. 3, pp. 1314–1317, Antalya, Turkey, September 1994.
- [14] E. Cerruto, A. Consoli, A. Raciti, and A. Testa, "Fuzzy logic based efficiency improvement of an urban electric vehicle," in *Proceedings of the 20th International Conference on Industrial Electronics, Control and Instrumentation (IECON '94)*, vol. 2, pp. 1304–1309, Bologna, Italy, September 1994.
- [15] S. Galichet and L. Foulloy, "Fuzzy controllers: synthesis and equivalences," *IEEE Transactions on Fuzzy Systems*, vol. 3, no. 2, pp. 140–148, 1995.
- [16] H.-D. Lee, E.-S. Koo, S.-K. Sul, and J.-S. Kim, "Torque control strategy for a parallel-hybrid vehicle using fuzzy logic," *IEEE Industry Applications Magazine*, vol. 6, no. 6, pp. 33–38, 2000.
- [17] A. Brahma, B. Glenn, Y. Guezennec, T. Miller, G. Rizzoni, and G. Washington, "Modeling, performance analysis and control design of a hybrid sport-utility vehicle," in *Proceedings of the IEEE International Conference on Control Applications (CCA '99)*, pp. 448–453, Kohala Coast, Hawaii, USA, August 1999.
- [18] B. M. Baumann, G. Washington, B. C. Glenn, and G. Rizzoni, "Mechatronic design and control of hybrid electric vehicles," *IEEE/ASME Transactions on Mechatronics*, vol. 5, no. 1, pp. 58–72, 2000.
- [19] C. W. Tao and J.-S. Taur, "Flexible complexity reduced PID-like fuzzy controllers," *IEEE Transactions on Systems, Man, and Cybernetics B: Cybernetics*, vol. 30, no. 4, pp. 510–516, 2000.
- [20] J.-S. Won and R. Langari, "Fuzzy torque distribution control for a parallel hybrid vehicle," *Expert Systems*, vol. 19, no. 1, pp. 4–10, 2002.
- [21] N. J. Schouten, M. A. Salman, and N. A. Kheir, "Fuzzy logic control for parallel hybrid vehicles," *IEEE Transactions on Control Systems Technology*, vol. 10, no. 3, pp. 460–468, 2002.
- [22] A. V. Patel and B. M. Mohan, "Analytical structures and analysis of the simplest fuzzy PI controllers," *Automatica*, vol. 38, no. 6, pp. 981–993, 2002.
- [23] R. Langari and J.-S. Won, "Integrated drive cycle analysis for fuzzy logic based energy management in hybrid vehicles," in *Proceedings of the 12th IEEE International Conference on Fuzzy Systems (FUZZ '03)*, pp. 290–295, Missouri, May 2003.
- [24] S. M. T. Bathaee, A. H. Gastaj, S. R. Emami, and M. Mohammadian, "A fuzzy-based supervisory robust control for parallel hybrid electric vehicles," in *Proceedings of the IEEE Conference Vehicle Power and Propulsion*, pp. 694–700, September 2005.
- [25] Q. Zeng and J. Huang, "The design and simulation of fuzzy logic controller for parallel hybrid electric vehicles," in *Proceedings of the IEEE International Conference on Automation and Logistics (ICAL '07)*, pp. 908–912, Jinan, China, August 2007.
- [26] F. Khoucha, M. E. H. Benbouzid, and A. Kheloui, "An optimal fuzzy logic power sharing strategy for parallel hybrid electric vehicles," in *Proceedings of the IEEE Vehicle Power and Propulsion Conference (VPPC '10)*, pp. 1–5, Lille, France, September 2010.
- [27] Z. Jianlong, Y. Chengliang, and Z. Jianwu, "Use of fuzzy controller for hybrid traction control system in hybrid electric vehicles," in *Proceedings of the IEEE International Conference on Mechatronics and Automation (ICMA '06)*, pp. 1351–1356, Luoyang, China, June 2006.
- [28] M. A. Golkar and A. Hajizadeh, "Power management strategy for parallel hybrid electric vehicles," in *Proceedings of the Joint International Conference on Sustainable Energy and Environment*, pp. 1–6, Bangkok, Thailand, November 2006.
- [29] F. U. Syed, M. L. Kuang, J. Czubay, and H. Ying, "Derivation and experimental validation of a power-split hybrid electric vehicle model," *IEEE Transactions on Vehicular Technology*, vol. 55, no. 6, pp. 1731–1747, 2006.
- [30] A. Poursamad and M. Montazeri, "Design of genetic-fuzzy control strategy for parallel hybrid electric vehicles," *Control Engineering Practice*, vol. 16, no. 7, pp. 861–873, 2008.
- [31] X. Liu, Y. Wu, and J. Duan, "Power split control strategy for a series hybrid electric vehicle using fuzzy logic," in *Proceedings of the IEEE International Conference on Automation and Logistics (ICAL '08)*, pp. 481–486, Qingdao, China, September 2008.
- [32] F. U. Syed, M. L. Kuang, M. Smith, S. Okubo, and H. Ying, "Fuzzy gain-scheduling proportional-integral control for improving engine power and speed behavior in a hybrid electric vehicle," *IEEE Transactions on Vehicular Technology*, vol. 58, no. 1, pp. 69–84, 2009.
- [33] M. Zhou, H. Zhang, and X. Wang, "Research on fuzzy energy management strategy of parallel hybrid electric vehicle," in *Proceedings of the International Conference on Electronic and Mechanical Engineering and Information Technology (EMEIT '11)*, pp. 967–971, Heilongjiang, China, August 2011.
- [34] J.-S. Won and R. Langari, "Intelligent energy management agent for a parallel hybrid vehicle," in *Proceeding of the American Control Conference*, pp. 935–956, Denver, Colo, USA, June 2003.
- [35] D. Lu, W. Li, G. Xu, and M. Zhou, "Fuzzy logic control approach to the energy management of parallel hybrid electric vehicles," in *Proceedings of the IEEE International Conference on Information and Automation (ICIA '12)*, pp. 592–596, Shenyang, China, June 2012.
- [36] S. Kachroudi, M. Grossard, and N. Abroug, "Predictive driving guidance of full electric vehicles using particle swarm optimization," *IEEE Transactions on Vehicular Technology*, vol. 61, no. 9, pp. 3909–3919, 2012.

- [37] Z. Fu, J. Xiao, and A. Gao, "Research on energy management and optimization for PHEV," in *Proceedings of the IEEE International Conference on Automation and Logistics (ICAL '12)*, pp. 578–582, Zhengzhou, China, August 2012.
- [38] S. Delprat, T. M. Guerra, G. Paganelli, J. Lauber, and M. Delhom, "Control strategy optimization for an hybrid parallel powertrain," in *Proceedings of the American Control Conference*, vol. 2, pp. 1315–1320, IEEE, Arlington, Va, USA, June 2001.
- [39] S. Delprat, T. M. Guerra, and J. Rimaux, "Optimal control of a parallel powertrain: from global optimization to real time control strategy," in *Proceedings of the 55th Vehicular Technology Conference*, pp. 2082–2088, Berlin, Germany, May 2002.
- [40] S. Delprat, T. M. Guerra, and J. Rimaux, "Control strategies for hybrid vehicles: synthesis and evaluation," in *Proceedings of the 58th IEEE Vehicular Technology Conference (VTC '03)*, vol. 5, pp. 3246–3250, October 2003.
- [41] S. G. Wirasingha and A. Emadi, "Classification and review of control strategies for plug-in hybrid electric vehicles," *IEEE Transactions on Vehicular Technology*, vol. 60, no. 1, pp. 111–122, 2011.
- [42] E. Tate and S. Boyd, "Finding ultimate limits of performance for hybrid electric vehicles," in *Proceedings of Society of Automotive Engineers 2000 Future Transportation Technology Conference*, vol. No of paper 2000-01-3099, 2001.
- [43] A. Kleimaier and D. Schroeder, "Optimization strategy for design and control of a hybrid vehicle," in *Proceedings of the 6th International Workshop on Advanced Motion Control*, pp. 459–464, Nagoya, Japan, April 2000.
- [44] P. Pisu, E. Silani, G. Rizzoni, and S. M. Savaresi, "A LMI-based supervisory robust control for hybrid vehicles," in *Proceedings of the American Control Conference*, pp. 4681–4686, Denver, Colo, USA, June 2003.
- [45] H. Miaohua and Y. Houyu, "Optimal design of control strategy for series hybrid electric bus," *Journal of Yuhan University of Technology*, vol. 4, 2004.
- [46] H. Mosbech, "Optimal control of hybrid vehicle," in *Proceedings of the International Symposium Automotive Technology and Automation*, pp. 303–320, 1980.
- [47] M. Oprean, V. Ionescu, N. Mocanu, S. Beloiu, and C. Stanciu, "Dynamic programming applied to hybrid vehicle control," in *Proceedings of the International Conference on Electric Drives (ICED '88)*, vol. 4, pp. D2/10/1–D2/10/20, 1988.
- [48] J. S. R. Jang, C. T. Sun, and E. Mizutani, *Neuro-Fuzzy and Soft Computing: A Computational Approach to Learning and Machine Intelligence*, Prentice Hall, New York, NY, USA, 1997.
- [49] A. Brahma, Y. Guezennec, and G. Rizzoni, "Optimal energy management in series HEV," in *Proceedings of the American Control Conference*, pp. 60–64, Columbus, Ohio, USA, 2000.
- [50] C.-C. Lin, J.-M. Kang, J. W. Grizzle, and H. Peng, "Energy management strategy for a parallel hybrid electric truck," in *Proceedings of the American Control Conference*, pp. 2878–2883, Ann Arbor, Mich, USA, June 2001.
- [51] O. Sundstrom, L. Guzzella, and P. Soltic, "Optimal hybridization in two parallel hybrid electric vehicles using dynamic programming," in *Proceedings of the 17th IFAC World Congress*, vol. 17, part 1, pp. 4642–4647, Seoul, Republic of Korea, 2008.
- [52] C.-C. Lin, H. Peng, J. W. Grizzle, and J.-M. Kang, "Power management strategy for a parallel hybrid electric truck," *IEEE Transactions on Control Systems Technology*, vol. 11, no. 6, pp. 839–849, 2003.
- [53] M. Koot, J. T. B. A. Kessels, B. de Jager, W. P. M. H. Heemels, P. P. J. van den Bosch, and M. Steinbuch, "Energy management strategies for vehicular electric power systems," *IEEE Transactions on Vehicular Technology*, vol. 54, no. 3, pp. 771–782, 2005.
- [54] M. P. O'Keefe and T. Markel, "Dynamic programming applied to investigate energy management strategies for a plug-in HEV1," in *Proceedings of the 22nd International Battery, Hybrid and Fuel Cell Electric Vehicle Symposium and Exposition (EVS '06)*, pp. 1035–1046, National Renewable Energy Laboratory, October 2006.
- [55] L. V. Pérez, G. R. Bossio, D. Moitre, and G. O. García, "Optimization of power management in an hybrid electric vehicle using dynamic programming," *Mathematics and Computers in Simulation*, vol. 73, no. 1–4, pp. 244–254, 2006.
- [56] Q. Gong, Y. Li, and Z. R. Peng, "Trip based power management of plug-in hybrid electric vehicle with two-scale dynamic programming," in *Proceedings of the IEEE Vehicle Power and Propulsion Conference (VPPC '07)*, pp. 12–19, IEEE, Arlington, Tex, USA, September 2007.
- [57] T. van Keulen, B. de Jager, and M. Steinbuch, "An adaptive sub-optimal energy management strategy for hybrid drive-trains," in *Proceedings of the 17th International Federation of Automatic Control World Congress (IFAC '08)*, vol. 17, pp. 102–107, July 2008.
- [58] Q. Gong, Y. Li, and Z.-R. Peng, "Computationally efficient optimal power management for plug-in hybrid electric vehicles based on spatial-domain two-scale dynamic programming," in *Proceedings of the IEEE International Conference on Vehicular Electronics and Safety (ICVES '08)*, pp. 90–95, Milwaukee, September 2008.
- [59] O. Sundström and L. Guzzella, "A generic dynamic programming Matlab function," in *Proceedings of the IEEE International Conference on Control Applications & Intelligent Control (CCA-ISC '09)*, pp. 1625–1630, Saint Petersburg, Russia, July 2009.
- [60] P. Tulpule, S. Stocker, V. Marano, and G. Rizzoni, "Optimality assessment of equivalent consumption minimization strategy for PHEV applications," in *Proceedings of the ASME Dynamic Systems and Control Conference*, Paper No. DSCC2009-2748, pp. 265–272, Hollywood, Calif, USA, October 2009.
- [61] P. Tulpule, V. Marano, and G. Rizzoni, "Energy management for plug-in hybrid electric vehicles using equivalent consumption minimisation strategy," *International Journal of Electric and Hybrid Vehicles*, vol. 2, no. 4, pp. 329–350, 2010.
- [62] C. Shen and X. Chaoying, "Optimal power split in a hybrid electric vehicle using improved dynamic programming," in *Proceedings of the Asia-Pacific Power and Energy Engineering Conference (APPEEC '10)*, pp. 1–4, Chengdu, China, March 2010.
- [63] D. V. Ngo, T. Hofman, M. Steinbuch, and A. F. A. Serrarens, "An optimal control-based algorithm for hybrid electric vehicle using preview route information," in *Proceedings of the American Control Conference (ACC '10)*, pp. 5818–5823, Baltimore, Md, USA, July 2010.
- [64] D. Kum, H. Peng, and N. K. Bucknor, "Optimal catalyst temperature management of plug-in hybrid electric vehicles," in *Proceedings of the American Control Conference (ACC '11)*, pp. 2732–2738, San Francisco, Calif, USA, June–July 2011.
- [65] Z. Zhou, C. Mi, Z. Chen, A. Masrur, and Y. L. Murphey, "Power management of passive multi-source hybrid electric vehicle," in *Proceedings of the IEEE Vehicle Power and Propulsion Conference (VPPC '11)*, pp. 1–4, Chicago, Ill, USA, September 2011.
- [66] Y. Li and N. C. Kar, "Advanced design approach of power split device of plug-in hybrid electric vehicles using dynamic programming," in *Proceedings of the 7th IEEE Vehicle Power and*

- Propulsion Conference (VPPC '11)*, pp. 1–6, Chicago, Ill, USA, September 2011.
- [67] A. Ravey, R. Roche, B. Blunier, and A. Miraoui, “Combined optimal sizing and energy management of hybrid electric vehicles,” in *Proceedings of the IEEE Transportation Electrification Conference and Exposition (ITEC '12)*, pp. 1–6, Dearborn, Mich, USA, June 2012.
- [68] M. Shams-Zahraei, A. Z. Kouzani, S. Kutter, and B. Bäker, “Integrated thermal and energy management of plug-in hybrid electric vehicles,” *Journal of Power Sources*, vol. 216, pp. 237–248, 2012.
- [69] C.-C. Lin, H. Peng, and J. W. Grizzle, “A stochastic control strategy for hybrid electric vehicles,” in *Proceedings of the American Control Conference (AAC '04)*, pp. 4710–4715, Boston, Mass, USA, June–July 2004.
- [70] E. D. Tate Jr., J. W. Grizzle, and H. Peng, “Shortest path stochastic control for hybrid electric vehicles,” *International Journal of Robust and Nonlinear Control*, vol. 18, no. 14, pp. 1409–1429, 2008.
- [71] J. Liu, J. Hagen, H. Peng, and Z. S. Filipi, “Engine-in-the-loop study of the stochastic dynamic programming optimal control design for a hybrid electric HMMWV,” *International Journal of Heavy Vehicle Systems*, vol. 15, no. 2–4, pp. 309–326.
- [72] E. D. Tate, J. W. Grizzle, and H. Peng, “SP-SDP for fuel consumption and tailpipe emissions minimization in an EVT hybrid,” *IEEE Transactions on Control Systems Technology*, vol. 18, no. 3, pp. 673–687, 2010.
- [73] S. J. Moura, H. K. Fathy, D. S. Callaway, and J. L. Stein, “A stochastic optimal control approach for power management in plug-in hybrid electric vehicles,” *IEEE Transactions on Control Systems Technology*, vol. 19, no. 3, pp. 545–555, 2011.
- [74] D. F. Opila, X. Wang, R. McGee, R. B. Gillespie, J. A. Cook, and J. W. Grizzle, “An energy management controller to optimally trade off fuel economy and drivability for hybrid vehicles,” *IEEE Transactions on Control Systems Technology*, vol. 20, no. 6, pp. 1490–1505, 2012.
- [75] Y. Wang and Z. Sun, “SDP-based extremum seeking energy management strategy for a power-split hybrid electric vehicle,” in *Proceedings of the American Control Conference (ACC '12)*, pp. 553–558, Fairmont Queen Elizabeth, Montréal, Canada, June 2012.
- [76] D. F. Opila, X. Wang, R. McGee, and J. W. Grizzle, “Real-time implementation and hardware testing of a hybrid vehicle energy management controller based on stochastic dynamic programming,” *Journal of Dynamic Systems, Measurement and Control, Transactions of the ASME*, vol. 135, no. 2, 11 pages, 2013.
- [77] A. Piccolo, L. Ippolito, V. Zo Galdi, and A. Vaccaro, “Optimization of energy flow management in hybrid electric vehicles via genetic algorithms,” in *Proceedings of the IEEE/ASME International Conference on Advanced Intelligent Mechatronics*, pp. 434–439, Como, Italy, July 2001.
- [78] L. Ippolito, V. Loia, and P. Siano, “Extended fuzzy c-means and genetic algorithms to optimize power flow management in hybrid electric vehicles,” in *Proceedings of the IEEE Conference on Control Applications*, vol. 1, pp. 115–119, Istanbul, Turkey, June 2003.
- [79] G. Wenzhong and S. K. Porandla, “Design optimization of a parallel hybrid electric powertrain,” in *Proceedings of the IEEE Vehicle Power and Propulsion Conference (VPPC '05)*, pp. 530–535, Chicago, Ill, USA, September 2005.
- [80] M. Montazeri-Gh and A. Poursamad, “Optimization of component sizes in parallel hybrid electric vehicles via genetic algorithms,” in *Proceedings of the ASME International Mechanical Engineering Congress and Exposition*, Paper No. IMECE2005-82338, pp. 225–232, Orlando, Fla, USA, November 2005.
- [81] P. G. Song, E. Y. Guan, L. Zhao, and S. P. Liu, “Hybrid electric vehicles with multilevel cascaded converter using genetic algorithm,” in *Proceedings of the 1st IEEE Conference on Industrial Electronics and Applications (ICIEA '06)*, pp. 1–6, Singapore, May 2006.
- [82] M. Montazeri-Gh and A. Poursamad, “Application of genetic algorithm for simultaneous optimization of HEV component sizing and control strategy,” *International Journal Alternative Propulsion*, vol. 1, no. 1, pp. 63–78, 2006.
- [83] X. Liu, Y. Wu, and J. Duan, “Optimal sizing of a series hybrid electric vehicle using a hybrid genetic algorithm,” in *Proceedings of the IEEE International Conference on Automation and Logistics (ICAL '07)*, pp. 1125–1129, Jinan, China, August 2007.
- [84] B. Zhang, Z. Chen, C. Mi, and Y. L. Murphey, “Multi-objective parameter optimization of a series hybrid electric vehicle using evolutionary algorithms,” in *Proceedings of the IEEE Vehicle Power and Propulsion Conference*, pp. 921–925, Dearborn, Mich, USA, September 2009.
- [85] A. Wang and W. Yang, “Design of energy management strategy in hybrid vehicles by evolutionary fuzzy system part I: fuzzy logic controller development,” in *Proceedings of the 6th World Congress on Intelligent Control and Automation (WCICA '06)*, vol. 2, pp. 8324–8328, Dalian, China, June 2006.
- [86] B. Huang, X. Shi, and Y. Xu, “Parameter optimization of power control strategy for series hybrid electric vehicle,” in *Proceedings of the IEEE Congress on Evolutionary Computation (CEC '06)*, pp. 1989–1994, Vancouver, Canada, July 2006.
- [87] B. Huang, Z. Wang, and Y. Xu, “Multi-objective genetic algorithm for hybrid electric vehicle parameter optimization,” in *Proceedings of the IEEE/RSJ International Conference on Intelligent Robots and Systems (IROS '06)*, pp. 5177–5182, October 2006.
- [88] L.-C. Fang and S.-Y. Qin, “Concurrent optimization for parameters of powertrain and control system of hybrid electric vehicle based on multi-objective genetic algorithms,” in *Proceedings of the SICE-ICASE International Joint Conference*, pp. 2424–2429, Busan, Republic of Korea, October 2006.
- [89] M. Montazeri-Gh, A. Poursamad, and B. Ghalichi, “Application of genetic algorithm for optimization of control strategy in parallel hybrid electric vehicles,” *Journal of the Franklin Institute*, vol. 343, no. 4-5, pp. 420–435, 2006.
- [90] M. Montazeri-Gh, A. Ahmadi, and M. Asadi, “Driving condition recognition for genetic-fuzzy HEV control,” in *Proceedings of the 3rd International Workshop on Genetic and Evolving Fuzzy Systems*, pp. 65–70, Witten-Bommerholz, Germany, March 2008.
- [91] R. S. Wimalendra, L. Udawatta, E. Edirisinghe, and S. Karunaratna, “Determination of maximum possible fuel economy of HEV for known drive cycle: genetic algorithm based approach,” in *Proceedings of the 4th International Conference on Information and Automation for Sustainability (ICIAFS '08)*, pp. 289–294, Colombo, Sri Lanka, December 2008.
- [92] T. Yi, Z. Xin, and Z. Liang, “Fuzzy-genetic control strategy of hybrid electric vehicle,” in *Proceedings of the 2nd International Conference on Intelligent Computing Technology and Automation (ICICTA '09)*, pp. 720–723, Zhangjiajie, China, October 2009.

- [93] C. Desai and S. S. Williamson, "Optimal design of a parallel hybrid electric vehicle using multi-objective genetic algorithms," in *Proceedings of the 5th IEEE Vehicle Power and Propulsion Conference (VPPC '09)*, pp. 871–876, Dearborn, Mich, USA, September 2009.
- [94] X. Hu, Z. Wang, L. Liao, and Z. Xiao, "Application of multi-objective evolutionary algorithm in hybrid electric vehicle design and control," *Journal of Wuhan University of Technology*, vol. 28, no. 3, pp. 384–387, 2004.
- [95] V. H. Johnson, K. B. Wipke, and D. J. Rausen, "HEV control strategy for real-time optimization of fuel economy and emissions," *Society Automotive Engineers*, vol. 109, no. 3, pp. 1677–1690, 2000.
- [96] G. Paganelli, M. Tateno, A. Brahma, G. Rizzoni, and Y. Guezennec, "Control development for a hybrid-electric sport-utility vehicle: strategy, implementation and field test results," in *Proceedings of the American Control Conference*, pp. 5064–5069, Columbus, Ohio, USA, June–July 2001.
- [97] N. Jalil, N. A. Kheir, and M. Salman, "Rule-based energy management strategy for a series hybrid vehicle," in *Proceedings of the American Control Conference*, pp. 689–693, Albuquerque, NM, USA, June 1997.
- [98] G. Paganelli, G. Ercole, A. Brahma, Y. Guezennec, and G. Rizzoni, "General supervisory control policy for the energy optimization of charge-sustaining Hybrid electric vehicles," *Society Automotive Engineers Review*, vol. 22, no. 4, pp. 511–518, 2001.
- [99] G. Paganelli, S. Delprat, T. M. Guerra, J. Rimaux, and J. J. Santin, "Equivalent consumption minimization strategy for parallel hybrid powertrains," in *Proceedings of the 55th Vehicular Technology Conference*, pp. 2076–2081, Vancouver, BC, Canada, May 2002.
- [100] J. G. Supina and S. Awad, "Optimization of the fuel economy of a hybrid electric vehicle," in *Proceedings of the 46th Midwest Symposium Circuits and Systems*, vol. 2, pp. 876–881, Cairo, Egypt, 2003.
- [101] A. Sciarretta, M. Back, and L. Guzzella, "Optimal control of parallel hybrid electric vehicles," *IEEE Transactions on Control Systems Technology*, vol. 12, no. 3, pp. 352–363, 2004.
- [102] J.-S. Won, R. Langari, and M. Ehsani, "An energy management and charge sustaining strategy for a parallel hybrid vehicle with CVT," *IEEE Transactions on Control Systems Technology*, vol. 13, no. 2, pp. 313–320, 2005.
- [103] P. Pisu and G. Rizzoni, "A supervisory control strategy for series hybrid electric vehicles with two energy storage systems," in *Proceedings of the IEEE Vehicle Power and Propulsion Conference (VPPC '05)*, pp. 65–72, Chicago, Ill, USA, September 2005.
- [104] B. Gu and G. Rizzoni, "An adaptive algorithm for hybrid electric vehicle energy management based on driving pattern recognition," in *Proceedings of the ASME International Mechanical Engineering Congress and Exposition*, pp. 249–258, Chicago, Ill, USA, 2006, Paper no. IMECE 2006-13951.
- [105] C. Musardo, G. Rizzoni, and B. Staccia, "A-ECMS: an adaptive algorithm for hybrid electric vehicle energy management," in *Proceedings of the 44th IEEE Conference on Decision and Control, and the European Control Conference (CDC-ECC '05)*, pp. 1816–1823, Seville, Spain, December 2005.
- [106] P. Pisu and G. Rizzoni, "A comparative study of supervisory control strategies for hybrid electric vehicles," *IEEE Transactions on Control Systems Technology*, vol. 15, no. 3, pp. 506–518, 2007.
- [107] F. R. Salmasi, "Control strategies for hybrid electric vehicles: evolution, classification, comparison, and future trends," *IEEE Transactions on Vehicular Technology*, vol. 56, no. 5, pp. 2393–2404, 2007.
- [108] A. Sciarretta and L. Guzzella, "Control of hybrid electric vehicles—a survey of optimal energy-management strategies," *IEEE Control Systems Magazine*, vol. 27, no. 2, pp. 60–70, 2007.
- [109] L. Xu, G. Cao, J. Li, F. Yang, L. Lu, and M. Ouyang, "Equivalent consumption minimization strategies of series hybrid city buses," in *Energy Management*, pp. 133–146, 2010.
- [110] G. Rousseau, D. Sinoquet, A. Sciarretta, and Y. Milhau, "Design optimization and optimal control for hybrid vehicles," in *Proceedings of the International Conference Engineering Optimization*, pp. 1–10, Rio de Janeiro, Brazil, 2008.
- [111] J.-P. Gao, G.-M. G. Zhu, E. G. Strangas, and F.-C. Sun, "Equivalent fuel consumption optimal control of a series hybrid electric vehicle," *Journal of Automobile Engineering*, vol. 223, no. 8, pp. 1003–1018, 2009.
- [112] P. Tulpule, V. Marano, and G. Rizzoni, "Effects of different PHEV control strategies on vehicle performance," in *Proceedings of the American Control Conference (ACC '09)*, pp. 3950–3955, St. Louis, Mo, USA, June 2009.
- [113] V. Marano, P. Tulpule, S. Stockar, and G. Rizzoni, "Comparative study of different control strategies for plug-in hybrid electric vehicles," in *Proceedings of the SAE International Conference on Engines and Vehicles*, Paper no. 2009-24-0071, Naples, Italy, 2009.
- [114] Y. He, M. Chowdhury, P. Pisu, and Y. Ma, "An energy optimization strategy for power-split drivetrain plug-in hybrid electric vehicles," *Transportation Research Part C: Emerging Technologies*, vol. 22, pp. 29–41, 2012.
- [115] N. Cui, J. Fan, C. Zhang, and J. Wu, "Research on predictive control based energy management strategy for hybrid electric vehicle," in *Proceedings of the 3rd IEEE International Symposium on Power Electronics for Distributed Generation Systems (PEDG '12)*, pp. 642–646, Aalborg, Denmark, June 2012.
- [116] M. J. West, C. M. Bingham, and N. Schofield, "Predictive control for energy management in all/more electric vehicles with multiple energy storage units," in *Proceedings of the IEEE International Electric Machines and Drives Conference*, M. J. West, Ed., pp. 222–228, June 2003.
- [117] M. Salman, M.-F. Chang, and J.-S. Chen, "Predictive energy management strategies for hybrid vehicles," in *Proceedings of the IEEE Vehicle Power and Propulsion Conference (VPPC '05)*, pp. 21–25, Clemson, SC, USA, September 2005.
- [118] R. Beck, F. Richert, A. Bollig et al., "Model predictive control of a parallel hybrid vehicle drivetrain," in *Proceedings of the 44th IEEE Conference on Decision and Control, and the European Control Conference*, pp. 2670–2675, Aachen, Germany, December 2005.
- [119] Y. Wang and S. Boyd, "Fast model predictive control using online optimization," in *Proceedings of the International Federation Automatic Control World Congress (IFAC '08)*, pp. 6974–6997, Seoul, Korea, July 2008.
- [120] S. Mahapatra, "Model-based design for hybrid electric vehicle systems," *Auto Electronics*, 2009, http://autoelectronics.com/powertrain/hybrid_electric_vehicles/model-based-design-for-hybrid-electric-vehicles-081109/.
- [121] S. Kermani, S. Delprat, T. M. Guerra, and R. Trigui, "Predictive control for HEV energy management: experimental results," in *Proceedings of the 5th IEEE Vehicle Power and Propulsion Conference (VPPC '09)*, pp. 364–369, Lille, France, September 2009.

- [122] B. Sampathnarayanan, L. Serrao, S. Onori, G. Rizzoni, and S. Yurkovich, "Model predictive control as an energy management strategy for hybrid electric vehicles," in *Proceedings of the ASME Dynamic Systems and Control Conference (DSCC '09)*, pp. 1161–1168, October 2009.
- [123] G. Ripaccioli, A. Bemporad, F. Assadian, C. Dextreit, S. D. Cairano, and I. Olmanovsky, "Hybrid modeling, identification, and predictive control: an application to hybrid electric vehicle energy management," in *Hybrid Systems: Computation and Control*, vol. 5469 of *Lecture Notes in Computer Science*, pp. 321–335, Springer, Berlin, Germany, 2009.
- [124] H. A. Borhan, C. Zhang, A. Vahidi, A. M. Phillips, M. L. Kuang, and S. Di Cairano, "Nonlinear model predictive control for power-split hybrid electric vehicles," in *Proceedings of the 49th IEEE Conference on Decision and Control (CDC '10)*, pp. 4890–4895, Clemson, SC, USA, December 2010.
- [125] G. Ripaccioli, D. Bernardini, S. Di Cairano, A. Bemporad, and I. V. Kolmanovsky, "A stochastic model predictive control approach for series hybrid electric vehicle power management," in *Proceedings of the International Conference Mechatronics and Automation*, pp. 4890–4895, Siena, Italy, 2011.
- [126] A. Vogal, D. Ramchandran, R. Gupta, and A. Raux, "Improving hybrid vehicle fuel efficiency using inverse reinforcement Learning," in *Proceeding of 26th AAAI Conference on Artificial Intelligence*, pp. 384–390, 2012.
- [127] H. Borhan, A. Vahidi, A. M. Phillips, M. L. Kuang, I. V. Kolmanovsky, and S. Di Cairano, "MPC-based energy management of a power-split hybrid electric vehicle," *IEEE Transactions on Control Systems Technology*, vol. 20, no. 3, pp. 593–603, 2012.
- [128] F. Yan, J. Wang, and K. Huang, "Hybrid electric vehicle model predictive control torque-split strategy incorporating engine transient characteristics," *IEEE Transactions on Vehicular Technology*, vol. 61, no. 6, pp. 2458–2467, 2012.
- [129] P. Poramapojana and B. Chen, "Minimizing HEV fuel consumption using model predictive control," in *Proceedings of the 8th IEEE/ASME International Conference on Mechatronic and Embedded Systems and Applications (MESA '12)*, pp. 148–153, Sozhou, China, July 2012.
- [130] B. Baumann, G. Rizzoni, and G. Washington, "Intelligent control of hybrid vehicles using neural networks and fuzzy logic," SAE Technical Paper no. 981061, Society of Automotive Engineers, 1998.
- [131] I. Arsie, M. Graziosi, C. Pianese, G. Rizzo, and M. Sorrentino, "Optimization of supervisory control strategy for parallel hybrid vehicle with provisional load estimate," *Advanced Vehicle Control*, pp. 483–488, 2004.
- [132] M. Mohebbi, M. Charkhgard, and M. Farrokhi, "Optimal neuro-fuzzy control of parallel hybrid electric vehicles," in *Proceedings of the IEEE Vehicle Power and Propulsion Conference (VPPC '05)*, pp. 26–30, Tehran, Iran, September 2005.
- [133] D. Prokhorov, "Toyota prius HEV neurocontrol," in *Proceedings of the International Joint Conference on Neural Networks (IJCNN '07)*, pp. 2129–2134, Orlando, Fla, USA, August 2007.
- [134] M.-J. Liu, "A fuzzy neural network control system based on improved learning algorithms," *Proceedings of the Chinese Society of Electrical Engineering*, vol. 27, no. 19, pp. 87–92, 2007.
- [135] M. Suzuki, S. Yamaguchi, T. Araki, P. Raksincharoensak, M. Yoshizawa, and M. Nagai, "Fuel economy improvement strategy for light duty hybrid truck based on fuel consumption computational model using neural network," in *Proceedings of the 7th World Congress*, International Federation of Automatic Control, pp. 10719–10725, Seoul, Korea, July 2008.
- [136] Q. Gong, Y. Li, and Z. Peng, "Power management of plug-in hybrid electric vehicles using neural network based trip modeling," in *Proceedings of the American Control Conference (ACC '09)*, pp. 4601–4606, St. Louis, Mo, USA, June 2009.
- [137] A. Boyali and L. Güvenç, "Real-time controller design for a parallel hybrid electric vehicle using neuro-dynamic programming method," in *Proceedings of the IEEE International Conference on Systems, Man and Cybernetics (SMC '10)*, pp. 4318–4324, Istanbul, Turkey, October 2010.
- [138] Y. L. Murphey, J. Park, L. Kiliaris et al., "Intelligent hybrid vehicle power control—part II: online intelligent energy management," *IEEE Transactions on Vehicular Technology*, vol. 62, no. 1, pp. 69–79, 2013.
- [139] R. C. Eberhart and J. Kennedy, "A new optimizer using particle swarm theory," in *Proceedings of the 6th International Symposium on Micro Machine and Human Science*, pp. 39–43, Nagoya, Japan, October 1995.
- [140] Y. Shi and R. C. Eberhart, "Parameter selection in particle swarm optimization," in *Proceedings of the 7th Annual Conference on Evolutionary Programming*, pp. 591–600, San Diego, Calif, USA, March 1998.
- [141] M. Huang and H. Yu, "Optimal multilevel hierarchical control strategy for parallel hybrid electric vehicle," in *Proceedings of the IEEE Vehicle Power and Propulsion Conference (VPPC '06)*, pp. 1–4, Windsor, UK, September 2006.
- [142] M. Huang and H. Yu, "Optimal control strategy based on PSO for powertrain of parallel Hybrid Electric Vehicle," in *Proceedings of the IEEE International Conference on Vehicular Electronics and Safety (ICVES '06)*, pp. 352–355, Beijing, China, December 2006.
- [143] Z. Wang, B. Huang, W. Li, and Y. Xu, "Particle swarm optimization for operational parameters of series hybrid electric vehicle," in *Proceedings of the IEEE International Conference on Robotics and Biomimetics (ROBIO '06)*, pp. 682–688, Kunming, China, December 2006.
- [144] J. Wu, C.-H. Zhang, and N.-X. Cui, "Fuzzy energy management strategy of parallel hybrid electric vehicle based on particle swarm optimization," *Control and Decision*, vol. 23, no. 1, pp. 46–50, 2008.
- [145] N. Al-Aawar, T. M. Hijazi, and A. A. Arkadan, "EM-TFL identification for particle swarm optimization of HEV powertrain," in *Proceedings of the IEEE International Electric Machines and Drives Conference (IEMDC '09)*, pp. 109–112, Miami, Fla, USA, May 2009.
- [146] C. Desai and S. S. Williamson, "Particle swarm optimization for efficient selection of hybrid electric vehicle design parameters," in *Proceedings of the 2nd IEEE Energy Conversion Congress and Exposition (ECCE '10)*, pp. 1623–1628, Atlanta, Ga, USA, September 2010.
- [147] O. Hegazy and J. Van Mierlo, "Particle swarm optimization for optimal powertrain component sizing and design of fuel cell hybrid electric vehicle," in *Proceedings of the 12th International Conference on Optimization of Electrical and Electronic Equipment*, pp. 601–609, Brasso, Romania, May 2010.
- [148] K. Varesi and A. Radan, "A novel PSO based technique for optimizing the DOH in hybrid electric vehicles to improve both the fuel economy and vehicle performance and reduce the emissions," in *Proceedings of the 2nd Power Electronics, Drive Systems and Technologies Conference (PEDSTC '11)*, pp. 342–349, Tehran, Iran, February 2011.
- [149] N. Al-Aawar, T. M. Hijazi, and A. A. Arkadan, "Particle swarm optimization of coupled electromechanical systems,"

- IEEE Transactions on Magnetics*, vol. 47, no. 5, pp. 1314–1317, 2011.
- [150] L. X. Z. Junhong, “Optimal energy management strategy for a plug-in hybrid electric vehicle based on particle swarm arithmetic,” *Journal Shanghai Auto*, vol. 5, p. 003, 2011.
- [151] W. Su and M. Y. Chow, “Performance evaluation of a PHEV parking station using particle swarm optimization,” in *Proceedings of the IEEE Power and Energy Society General Meeting*, pp. 1–6, San Diego, Calif, USA, July 2011.
- [152] L. Wu, Y. Wang, X. Yuan, and Z. Chen, “Multiobjective optimization of HEV fuel economy and emissions using the self-adaptive differential evolution algorithm,” *IEEE Transactions on Vehicular Technology*, vol. 60, no. 6, pp. 2458–2470, 2011.
- [153] V. F. Krotov, *Global Methods in Optimal Control Theory*, Marcel Dekker, New York, NY, USA, 1996.
- [154] H. Geering, *Optimal Control with Engineering Applications*, Springer, New York, NY, USA, 2007.
- [155] L. Serrao and G. Rizzoni, “Optimal control of power split for a hybrid electric refuse vehicle,” in *Proceedings of the American Control Conference (ACC '08)*, pp. 4498–4503, Washington, D.C., USA, June 2008.
- [156] N. Kim, D. Lee, S. W. Cha, and H. Peng, “Optimal control of a plug-in hybrid electric vehicle (PHEV) based on driving patterns,” in *Proceedings of the 24th International Battery, Hybrid and Fuel Cell Electric Vehicle Symposium*, pp. 1–9, Stavanger, Norway, 2009.
- [157] S. Stockar, V. Marano, G. Rizzoni, and L. Guzzella, “Optimal control for Plug-in Hybrid Electric vehicle applications,” in *Proceedings of the American Control Conference (ACC '10)*, pp. 5024–5030, Baltimore, Md, USA, July 2010.
- [158] S. Stockar, V. Marano, M. Canova, G. Rizzoni, and L. Guzzella, “Energy-optimal control of plug-in hybrid electric vehicles for real-world driving cycles,” *IEEE Transactions on Vehicular Technology*, vol. 60, no. 7, pp. 2949–2962, 2011.
- [159] A. Chasse and A. Sciarretta, “Supervisory control of hybrid powertrains: An experimental benchmark of offline optimization and online energy management,” *Control Engineering Practice*, vol. 19, no. 11, pp. 1253–1265, 2011.
- [160] N. Kim, S. Cha, and H. Peng, “Optimal control of hybrid electric vehicles based on Pontryagin’s minimum principle,” *IEEE Transactions on Control Systems Technology*, vol. 19, no. 5, pp. 1279–1287, 2011.
- [161] N. Kim, A. Rousseau, and D. Lee, “A jump condition of PMP-based control for PHEVs,” *Journal of Power Sources*, vol. 196, no. 23, pp. 10380–10386, 2011.
- [162] N. Kim, S. W. Cha, and H. Peng, “Optimal equivalent fuel consumption for hybrid electric vehicles,” *IEEE Transactions on Control Systems Technology*, vol. 20, no. 3, pp. 817–825, 2012.
- [163] C. Zhang, J. Wu, and N. Cui, “Energy management strategy of parallel hybrid electric vehicle with continuously variable transmission,” *Chinese Journal of Mechanical Engineering*, vol. 43, no. 10, pp. 114–118, 2007.
- [164] X. Hui and D. Yunbo, “The study of plug-in hybrid electric vehicle power management strategy simulation,” in *Proceedings of the IEEE Vehicle Power and Propulsion Conference (VPPC '08)*, pp. 1–3, Harbin, China, September 2008.
- [165] M. Ceraolo, A. di Donato, and G. Franceschi, “A general approach to energy optimization of hybrid electric vehicles,” *IEEE Transactions on Vehicular Technology*, vol. 57, no. 3, pp. 1433–1441, 2008.
- [166] H. Khayyam, A. Z. Kouzani, and E. J. Hu, “An intelligent energy management model for a parallel hybrid vehicle under combined loads,” in *Proceedings of the IEEE International Conference on Vehicular Electronics and Safety*, pp. 145–150, Columbus, Ohio, USA, September 2008.
- [167] S. Amjad, S. Vinayaga, N. Moorthi, R. Rudramoorthy, and D. V. R. Rudramoorthy, “A novel approach for energy management in plug-in hybrid electric vehicle (PHEV),” SAE Technical Paper 2008-28-0046, 2008.
- [168] J. Ji, J. Park, O. Kwon, and H. Kim, “An energy management strategy for a CVT based parallel hybrid electric vehicle,” in *Proceedings of the IEEE Vehicle Power and Propulsion Conference (VPPC '12)*, pp. 380–382, Seoul, Republic of Korea, October 2012.
- [169] R. Shankar, J. Marco, and F. Assadian, “Design of an optimized charge-blended energy management strategy for a plugin hybrid vehicle,” in *Proceedings of the UKACC International Conference on Control (CONTROL '12)*, pp. 619–624, September 2012.
- [170] S. Fekri and F. Assadian, “The role and use of robust multivariable control in hybrid electric vehicle energy management—part I: an overview,” in *Proceedings of the IEEE International Conference on Control Applications (CCA '12)*, pp. 303–309, Dubrovnik, Croatia, October 2012.
- [171] S. K. Shahi, G. G. Wang, L. An, E. Bibeau, and Z. Pirmoradi, “Using the Pareto set pursuing multiobjective optimization approach for hybridization of a plug-in hybrid electric vehicle,” *Journal of Mechanical Design*, vol. 134, no. 9, Article ID 094503, 2012.



Hindawi

Submit your manuscripts at
<http://www.hindawi.com>

