

Design of Dielectric Accelerator Using TE-TM Mode Converter

Wanming Liu, Wei Gai

*Argonne National Laboratory,
Argonne, IL, 60439*

Abstract. A new design for X band dielectric accelerator using a TE-TM mode converter has been proposed and studied. It first converts RF from TE to TM mode in a pure metal section, then a tapered transition section is used for high efficiency transmission to the dielectric accelerator section. Because there is no dielectrics near the RF coupler, this scheme has potential to overcome RF breakdown problems near the coupling holes in the dielectric based accelerators, as it happened in the older designs. A detailed design study shows that high conversion efficiency (~100%) can be achieved for both single and dual coupling ports and it is less sensitive to machine errors than previous designs. Another advantage of this design is that it can be made to different modules thus greatly reduce the R&D cycles.

INTRODUCTION

Dielectric loaded accelerating structures were proposed in the early 1950's [1]. Since then, this class of device has been studied both theoretically and experimentally [2, 3, 4, 5, 6]. The advantages and potential problems of using dielectrics are discussed in the above references and summarized in [5]. Some potential long-term challenges of using dielectric material in a high power RF environment are breakdown and thermal heating. One practical problem that has arisen during prototyping the dielectric accelerator is the difficulty of efficiently coupling RF power into the structure [5,6]. One scheme for solving this problem proposed and studied in [5] by P. Zou consists of a combination of a side coupling slot and a tapered dielectric layer near the slot. Simulations and low power test results show that the scheme is adequate; high power tests however were unsuccessful due to rf breakdown in the vicinity of the coupling slot [7, J. Power, in this proceeding], which is similar results to the previous work[6].

To solve the coupling problem, we have adopted a scheme proposed by Tantawi and Natista [8, private communication] that uses a TE-TM converter as coupling structure. The similar scheme were also studied by I. Syratchev for CLIC accelerating structure[9]. YU [10] and Liu [11] investigated the same type RF extraction methods for high power generation using dielectric lined structure. Our scheme is shown in Figure 1, it shows that a transition piece is used to convert TE mode (in rectangular waveguide) to TM mode (in cylindrical copper waveguide). Then a tapered dielectric

section is used to transmit RF power into the dielectric accelerator section. This scheme separates the dielectric loaded accelerator away from the coupling structure by a tapered section. Such scheme makes the coupler independent of the dielectric properties, and highest fields are in the accelerator section. Because the coupler is implemented on a section of regular circular waveguide, the aperture of the coupling slot is much bigger than in the old scheme and this makes the peak value of EM field much smaller than that of the old scheme under the same power input.

One could also make the structure design shown in Figure 1 into several modules: 1) Coupling section; 2) Dielectric tapered section and 3) Dielectric accelerator section. This would greatly simplify the experimental implementations of high power testing because one only needs to build different dielectric accelerator or tapered section once couplers can be proven to handle high RF powers.

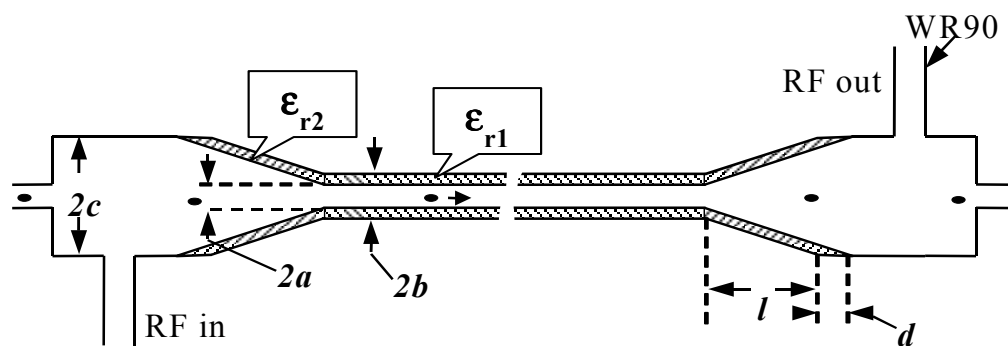

FIGURE 1. Example of an 11.424 GHz Structure of the new scheme.

In this paper, we will concentrate on the design of RF coupling structure and tapered section and present a detailed results in the following sections, because the properties of the acceleration section was studied in details previously [5,6]. The reference design given here is for two dielectric materials, Alumina ($\epsilon_r=9.4$) and MCT20 ($\epsilon_r=20$). However, the coupling section is the same for both dielectrics and it only differs in tapered section. The choice of parameters is summarized in table I.

	a(mm)	b(mm)	c(mm)
$\epsilon_r=9.4$	5	7.185	12.079
$\epsilon_r=20$	2.96	4.53	12.079

Taper section design

Purpose of the taper section is to match the impedance between the dielectric loaded circular waveguide and the regular metal circular waveguide where the coupler is implemented, thus achieve high transmissions. The tapered section is acting as a broadband $\lambda/4$ transformer that matches impedance of two circular waveguides.

As shown in figure 1, the geometry of taper section is determined by its length l when the diameters of both dielectric loaded waveguide and the regular waveguide are predetermined. The dielectric constant of the taper can be somewhat different from the dielectric in accelerating section. The parameter d is determined by $d = \frac{b-a}{c-b} l$. The goal of taper section design is to find out a proper length l with acceptable S_{11} , which is a measure of reflection coefficient. The EM simulation tool used here is MicroWave Studio by CST [12]. The simulation results for both $\epsilon_{r1} = 9.4$ and $\epsilon_{r1} = 20$ tapered sections are given in figure 2 and 3 respectively, it shows the reflection coefficient as function of l . For narrow band frequency application, we can

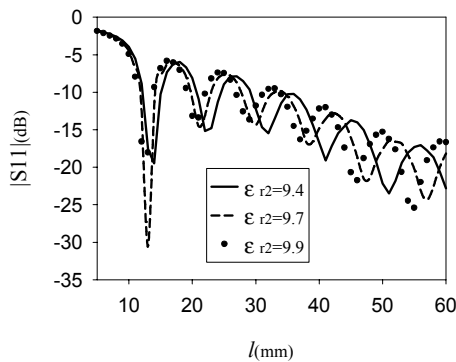

FIGURE 2. S parameter of taper section.
Dielectric constant $\epsilon_r = 9.4$

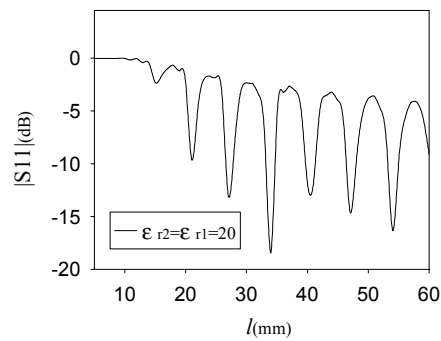

FIGURE 3. S parameter of taper section.
Dielectric constant $\epsilon_r = 20$

get very good matching with shorter taper section. However, as illustrated in figure 3, the bandwidth can be much narrower for dielectric constant equals 20. Thus it implies high degree precision requirements. With the optimized taper section, we can conduct the TM01 mode from circular waveguide into the accelerating section with maximum efficiency.

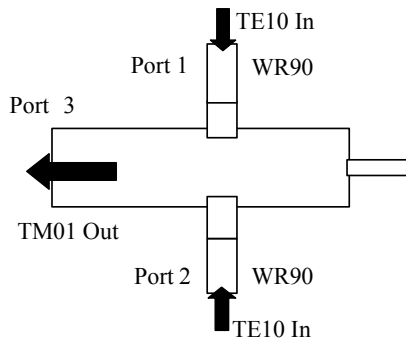

FIGURE 4a. Scheme of the dual side coupler

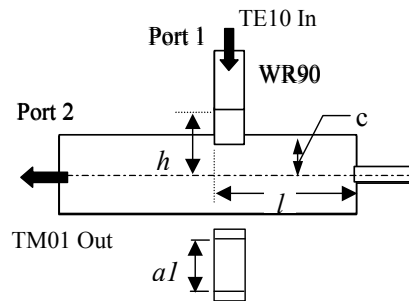

FIGURE 4b. Scheme of the single side coupler

TE-TM RF Coupler design

For a good coupler design for any accelerating structure, it needs not only the good matching but also the maximum mode conversion from the rectangular TE₁₀ mode into circular TM₀₁ accelerating mode. We consider two types of TE₁₀-TM₀₁ couplers for our dielectric accelerating structure design. One is the dual side symmetric coupler, the other is the single side coupler as illustrated in Figure 4a and 4b, respectively.

Dual side symmetric coupler

As shown in figure 4a, this type of coupler is consist of a circular waveguide and two symmetrically located rectangular coupling slots on it. Most recent designs for

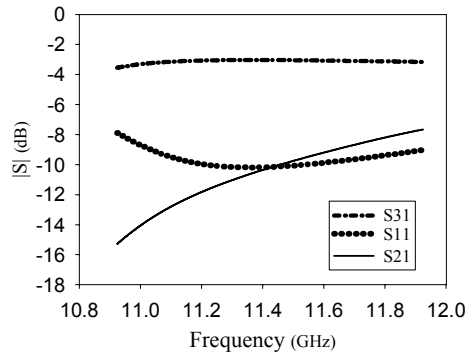

FIGURE 5. S parameters of dual side coupler

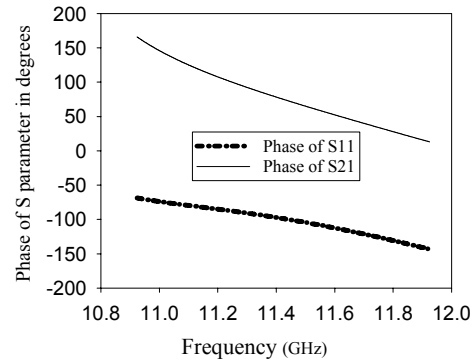

FIGURE 6. Phase of S parameters

future linear colliders use two coupling ports. By using two ports design, one can eliminate field asymmetry in the coupler region and also minimize the beam break up (BBU) effects. A transition section is used to provide matching for WR90 waveguide. It's obvious that the two symmetrically located coupling ports will communicate to each other, which means that some of the energy coupling in from one port will come out from another port. In order to assure that no powers are transmitted through one port to other and also no apparent reflection from the port, one can make the S₁₁ equals to S₁₂ in amplitude and has a phase difference of 180° by adjust the width of the coupling slots (a₁), the length of the transition section (d) and the distance between the location of coupling slot and the end of the circular waveguide (l). Thus the reflected wave from coupling slot is canceled by the wave transferred from another slot if the input at both port are in the same phase and amplitude.

The S parameters of the dual side coupler structure are given in figure 5. As shown in figure 5, S₁₁ is approximately equals to S₂₁ in amplitude at 11.424GHz. Figure 6 shows the phases for S₁₁ and S₂₁. From figure 6, it is noticed that the phase difference of S₁₁ and S₂₁ is about 175° at 11.424GHz. Under such conditions, the

SWR in WR90 is found out to be about 1.085 at 11.424GHz, which gives a reflection of -28dB

Single side coupler

As high power test experiment planned at high power X-band facility at the Naval Research Laboratory, it is much more convenient to test a structure with only a single RF coupling port. Although it is difficult to implement single port design for practical high energy linear colliders, but this would satisfy our requirements high power test of dielectric based accelerators because field asymmetry and wakefield induced instabilities are not concerns here. We have developed a single port design by simply modify the parameters for the dual side coupler. A set of parameters were found to give maximize the efficiency of mode conversion from rectangular TE₁₀ to circular TM₀₁ mode as illustrated in figure 4b. We obtained the optimized structure by optimize parameters shown in figure 4b. The S parameters of the optimized single side structure are given in figure 7. As shown in figure 7, S₂₁ is almost 0 dB in the region of 11.424GHz, which means that nearly 100% of energy from rectangular TE₁₀ has been converted into circular TM₀₁. Peak electrical fields around the corners (blended at a radius of 2mm) of the coupling slot are to be less than 40 MV/m for 100 MW RF power, which is well below the copper surface breakdown threshold.

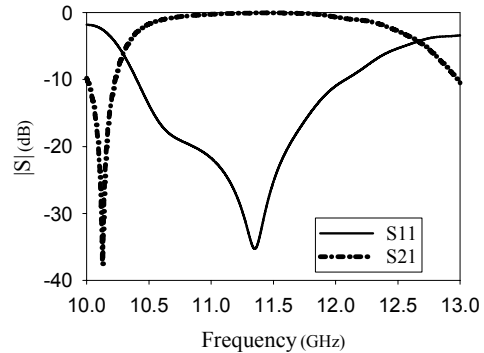

FIGURE 7. S parameters of the single side coupler

Tolerance issues.

The sensitivity of the mode coupler's performance to deviations from the nominal geometry was studied by varying the geometry parameters around the optimized structure for the single side coupler. Figure 8 shows the S parameter at 11.424GHz

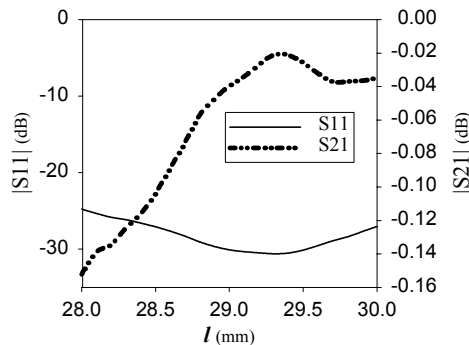

FIGURE 8. S parameters of single side coupler at 11.424GHz varying with l

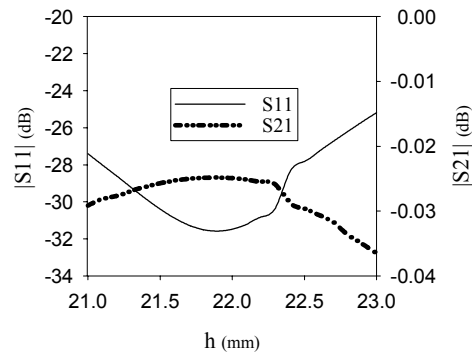

FIGURE 9. S parameters of single side coupler at 11.424GHz varying with h

varying with l as shown in figure 4b. From figure 8, it shows when l changes from 28mm to 30mm the S11 stayed below -25 dB and S21 is above -0.16 dB. The S parameter dependence on other device parameters such as h and al was also calculated (fig. 9 – 10) and found to be weak.

The effect of fabrication error in the radius of circular waveguide was also simulated. The results show that an error as large as 0.2 mm in radius will not cause any problems, greatly reducing the requirements on the machining tolerances.

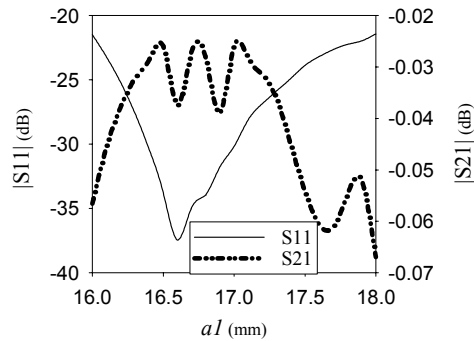

FIGURE 10. S parameters of single side coupler at 11.424GHz varying with al

Summary

A new scheme of coupling rf into a dielectric accelerating structure has been studied in this paper. This new design separate the coupler from the dielectric loaded accelerating structure by a tapered transition section. This would eliminate the arcing problems observed during previous high power tests [John Power]. Both dual port and single port couplers have been investigated. We found that both type are capable of converting the rectangular TE₁₀ mode into circular TM₀₁ mode with efficiency above 99% over a relatively wide bandwidth. For the current high power experiments at NRL, we will use the single side coupler for its simplicity in implementation. The single port and transition sections are under construction and will be high power tested soon. Once we demonstrate that high power can be transmitted through the coupling port, high gradient dielectric accelerator tests will follow.

This work is supported by DOE, High Energy Physics, Advanced Technology branch. We acknowledge the useful discussion with S. Gold, S. Tantawi, C. Natista, I Syratcev and D. Yu during this work.

REFERECES

1. G. Flesher and G. Cohn, AIEE Trans. 70, 887 (1951)
2. R. Kenigs, M. Jones, and W. Gai, Particle Accel. **24**, 223 (1989) and W. Gai et al, Physical Rev. Lett, **61**, 24, p2756 (1988)
3. T-B Zhang, J. Hirshfield, T. Marshall, and B. Hafizi, Phys. Rev. E **56**, 4447(1997) and T. B. Zhang, T. C. Marshall, M. A. LaPointe, J. L. Hirshfield, and A. Ron, Phys. Rev. E **54**, 1918-1929 (1996)
4. W. Gai, R.Konecny, and J. Simpson, in Proceedings of Particle Accelerator Conference, edited by M. Comyn, M.K. Craddock, M. Reiser and J. Thomson, pp. 636-638, 1997,
5. P. Zou, W.Gai, R. Konecny, X.Sun, T. Wong and A. Kanareykin, Rev. Of Scientific Instruments, **71**, 2301-2304(2000)

6. J.-M. Fang† and T.C. Marshall, M.A. LaPointe and J.L. Hirshfield, “An Experimental Test of a Microwave Inverse Cerenkov Accelerator (MICA)”, Proceedings of the 2001 Particle Accelerator Conference, Edited by P. Lucas, S. Webber, Chicago, IL, p4240
7. J. Power et al, in this proceeding
8. S. Tantawi and C. Nantista, private communications
9. I. Syratchev, CLIC Note 505, CERN 2001, unpublished
10. D. Yu , “Ceramic RF Power Extractor”, Proceedings of 9th Linear Collider Worksop,2002, SLAC, and also D.Yu, P.Wilson, "Sheet beam klystron rf cavities", Proc. PAC 1993,p.2681.S.Ben-Menahem, D.Yu, "Coax sidearm coupler", Proc. Pulsed RF Sources for LC, Montauk, NY 1994, p.332. maybe others
11. W. Gai and W. Liu, “MAFIA Simulation of a 21 GHz Dielectric Based Power Extraction and Transfer Structure for CLIC Application” Proceedings of 9th Linear Collider Worksop,2002, SLAC
12. Microwave Studio, Version 3.4 CST America, <http://www.cst-america.com>