

## Research Article

# An Extensive QFD and Evaluation Procedure for Innovative Design

Chang-Tzuoh Wu,<sup>1</sup> Tien-Szu Pan,<sup>2</sup> Ming-Hui Shao,<sup>3</sup> and Chang-Shiann Wu<sup>4</sup>

<sup>1</sup> Department of Industrial Design, National Kaohsiung Normal University, No. 62, Shenjhong Road, Yanchao District, Kaohsiung City 82446, Taiwan

<sup>2</sup> Department of Electronic Engineering, National Kaohsiung University of Applied Science, 415 Chien Kung Road, Sanmin District, Kaohsiung 80778, Taiwan

<sup>3</sup> Department of Industrial Design, National Cheng Kung University, No. 1, University Road, Huwei Township, Tainan City 701, Taiwan

<sup>4</sup> Department of Information Management, National Formosa University, No. 64, Wunhua Road, Huwei Township, Yunlin County 632, Taiwan

Correspondence should be addressed to Chang-Tzuoh Wu; [ctwu@nknuc.nknu.edu.tw](mailto:ctwu@nknuc.nknu.edu.tw)

Received 15 September 2013; Accepted 21 October 2013

Academic Editor: Teen-Hang Meen

Copyright © 2013 Chang-Tzuoh Wu et al. This is an open access article distributed under the Creative Commons Attribution License, which permits unrestricted use, distribution, and reproduction in any medium, provided the original work is properly cited.

In this paper, a systematic innovation procedure has been developed based on quality function deployment and extension method. Besides, the evaluation method for design decision making has also been discussed and developed. The major procedure of QFD is to identify the customers' needs for the product and then convert into appropriate technical measures to fulfill the needs based on the company's competitive priorities. The priorities of product characteristics can be obtained by translating important technical measures. According to their characteristics, the prior engineering parameters will be identified and selected as the key requirements to redesign. This paper will focus on the integration of QFD and extension method. With the help of "matter element theory and extension method," customer requirements (CRs) can be transferred into product design attributes more comprehensively and deeply. According to the idea of loss function of Taguchi quality design method, the criteria for design decision making have also been developed in this paper. An innovative design case, bicycle, successfully demonstrates that the proposed design process is feasible and efficient.

## 1. Introduction

A successful new product development should meet various customer demands. Hence, analyzing customer requirements (the voice of customers) and responding to their needs has now become an important and inevitable task for a company's product development team [1].

Quality function deployment (QFD) is an important quality control theory proposed by the Japanese quality control master Yoji Akao in 1966. It was Akao who first realized the value of this approach in 1969 and wanted to utilize its power during the product design stage so that the product design characteristics could be converted into precise

quality control points in the manufacturing quality control chart [2]. Sullivan, 1986 indicated that quality function deployment (QFD) provides a means of translating customer requirements into the appropriate technical requirements for each stage of product development [3, 4].

Delice and Cüngör, 2009 indicated that, in real world applications, the values of DRs are often discrete instead of continuous. A new QFD optimization approach combining MILP model and Kano model is suggested to acquire the optimized solution from a limited number of alternative DRs, the values of which can be discrete [1]. Garibay et al. (2010) proposed a tool which utilized a combination of the quality function Deployment (QFD)-Kano model to evaluate

service quality. Relevant information may be obtained about issues that should be improved in order to increase customer satisfaction by listening to the voice of the customer (VOC) [5].

Most of the associated researches provide valuable and valid methods to enhance the effect of QFD. Though these studies applied successfully the proposed methods to solve design problems, they focused on local perspective view only. This paper will concentrate on the creative thinking method, "matter element theory and extension method," with the help of this method to assist in translating customer requirements (CRs) into engineering characteristics (ECs) more deeply and widely.

## 2. Innovative Design Method

*2.1. Quality Function Deployment.* QFD is a structured design tool and is defined as "a consumers' needs oriented tool" which can be used to establish the relationship between customer attributes and design parameters to be quantified through the house of quality and customers' cognition, finding key design factors in the product to determine the direction of product development and market positioning. As shown in Figure 1, the four-phase approach consists of product planning, part deployment, process planning, and production planning phases [6]. In essence, the product planning phase translates qualitative customer requirements into measurable engineering characteristics and identifies important engineering characteristics. The goal of product planning phase is to translate customer requirements (CRs) into engineering characteristics (ECs) and prioritize their importance. Therefore, the CRs must be acquired from market surveys or customer questionnaires. The acquired information can be used to calculate the relative importance of CRs, calculate the final importance of CRs, and identify the ECs, so that the final importance of ECs will be calculated and the relationship matrix also be established.

*2.2. Matter-Element Analysis and Extension Method.* Cai, 1983 developed a powerful tool, matter-element and extension method, to systematically analyze concrete or intangible products. Extension theory is a course to study the extensibility, extent rules, and performing procedure of matter and try to resolve contradictive problems. Extension theory and method are the new science. Their application to the research on conceptual design of the products and innovative design is a new field. The extension method can help people resolve problems separately by decomposing and recombining the problems to search for the feasible solutions.

A matter element can be combined with the other matter elements to form a new one or be decomposed into a few new matter-elements; new matter elements contain qualities that former matter elements do not have. The extension of matter element provides another way of resolving contradiction. Matter element can be used to describe every matter in real world. We use an ordered triad

$$R(N, c, v). \quad (1)$$

The basic element for describing the matter  $N$  is called matter element, where  $N$  represents the matter;  $c$  is the characteristic name;  $v$  is  $N$  measure about  $c$ . Thus,  $v = c(N)$ .

The extensibility of matter element is the basis of dealing with incompatible problem. It includes divergence, expansibility, conjugate inside the matters, and relativity of matter element. Divergence is to study the possible routes of outward extension. It includes the same matter of matter element, the same characteristics of matter-element, the measure of matter element, the same matter and characteristics of matter element, the same characteristics and measure of matter element, and the same matter and measure of matter-element. Extensibility studies plausibility, integration, and separability of matter element [8, 9].

Replacement, decomposition, addition/deletion, and expansion/contraction are four basic methods for transformation of matter element and conducive to exchanging or to synthesizing different matter element. As shown in Figure 2, general model of extending tree constructed by matter element symbols expresses the divergence in simple way [10, 11].

Study of the internal structure of matter is contributive to solving contradictive problems by using any element of matters. Systems theory, a description of structures of matters, is a science to study matters from system components and internal-external relationships. Through the analysis of a large number of matters, we found that the properties of substance, dynamic, and opposition can also be the research topics of the structure of matters in addition to systemic property. A matter consists of the tangible part and intangible part of substance, both of which should also be considered. As for the dynamic properties, matter has the significant part and potential part. Such as the development of the disease, it generally includes the incubation period and the exacerbation period.

The structure of matter can be described more completely and the nature of variation of the development of matters can also be revealed more deeply while we explore the matter from the point of view of systemic, substance, dynamic, and opposition [7, 12]. Therefore, we proposed the corresponding four pairs of opposing concepts such as real/imaginary, soft/hard, potential/significant, and positive/negative to describe the composition of matters called conjugate of matters.

## 3. Extensible QFD

Customer needs orientation is the principal spirit of QFD. The conversion between functional quality and engineering design parameters is the important creativity thinking course for the fulfillment of the customer needs oriented innovative design.

The major procedure of QFD is to identify the customers' needs for the product and then convert into appropriate technical measures to fulfill the needs based on the company's competitive priorities. The priorities of product characteristics can be obtained by translating important technical measures. According to their characteristics, the prior engineering

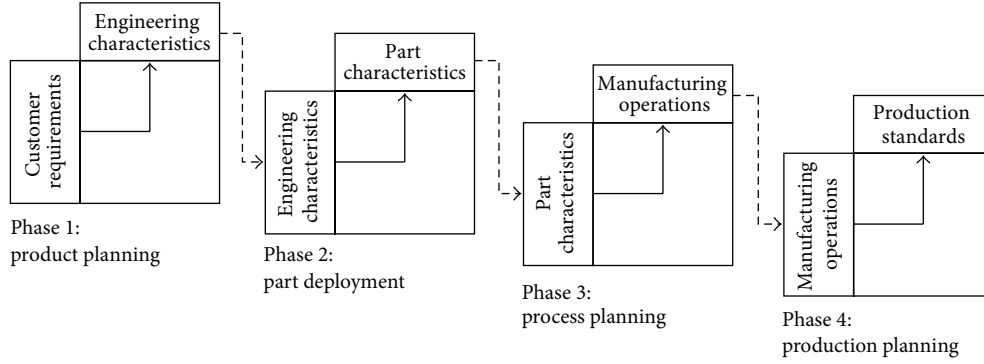

FIGURE 1: Four-phase approach of QFD [7].

parameters will be identified and selected as the key requirements to redesign. Throughout the procedure, the creativity activities with matter-element theory and extension method can be imported or expanded mainly in two parts:

- (1) translating customers' needs into product design attributes (technical measures),
- (2) identifying the corresponding product defect or the parameters needed to be improved.

The use of extensibility of matter element and extension method for the translation of product design attributes and engineering properties can provide effective assistance for the designer to conceive new products comprehensively and deeply. In this research, we will discuss the procedure for improving design attributes by the aids of extensibility of matter element and extension method.

Matter element and matter element with multicharacteristics are defined as follows.

Matter element

$$R = (N(t), c, v(t)), \quad (2)$$

matter element with multicharacteristics

$$R(t) = \begin{bmatrix} N(t) & c_1 & v_1(t) \\ & c_2 & v_2(t) \\ & \vdots & \vdots \\ & c_n & v_n(t) \end{bmatrix} = (N(t), C, V(t)). \quad (3)$$

Based on the divergence of matter element, matter element  $R_0(N_0, c_0, v_0)$  can be diverged from one or two of  $N_0, c_0, v_0$  to synthesize different matter elements and build an extending tree. Extending tree, part of rhombus thinking model, is a method for matter to extend outwards to provide multiorientated, organizational and structural considerations, as operating in Figure 2. An event is the interaction of matters and described as event element. Basic elements for describing an event element are constructed by verb ( $d$ ), name of verb characteristic ( $b$ ) and  $u$ , the corresponding measure about ( $b$ ).

Event element:

$$I(t) = (d(t), b, u(t)). \quad (4)$$

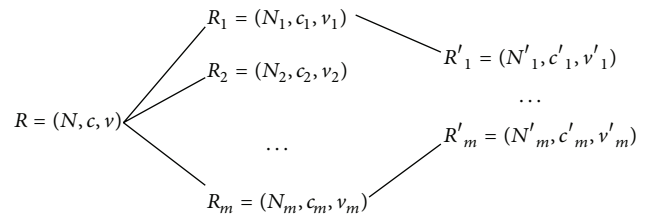

FIGURE 2: Rhombus thinking model.

Multidimensional event element:

$$I(t) = (d(t), B, U(t)). \quad (5)$$

Relationship element is formed by relationship name  $s(t)$ , characteristics  $a_1, a_2, \dots, a_n$ , and corresponding measure values  $w_1(t), w_2(t), \dots, w_n(t)$ :

$$Q(t) = \begin{bmatrix} S(t) & a_1 & w_1(t) \\ & a_2 & w_2(t) \\ & \vdots & \vdots \\ & a_n & w_n(t) \end{bmatrix} = (S(t), A, W(t)). \quad (6)$$

While solving design problems, diversity, and creativity, the advantages of "extenics" method will be imported by implementing the extensibility of matter element, event element and relationship element. Thus, the solution will not be limited to standard solutions but will be inspired.

**3.1. Procedure for Engineering Design Parameters Transformation.** Throughout the procedure of QFD, the extensibility of matter element and extension method can be used to assist in translating product functional requirements into engineering design parameters. The following are the steps of creative activities, thus matter element which matter element theory and extension method can be imported or expanded.

*Step 1.* Define the  $n$ -dimensional matter element of product.

*Step 2.* Determine the  $m$ -dimensional requirements matter element.

The  $m$ -dimensional characteristics of requirements matter element can be formed by the attributes derived from customers' voices.

*Step 3.* Determine the functional characteristics set.

Determine the set of functional characteristics of product requirements based on  $m$ -dimensional requirements matter element. The corresponding values of the functional characteristic elements should also be determined as the following equation:

$$\begin{aligned} \{c_{\text{function}}\} &= \{c_f\} \\ &= \{(c_f, v_f)\}. \end{aligned} \quad (7)$$

*Step 4.* Confirm the "hypostatic characteristics."

List all the associated properties of characteristics which can improve the required functions. No matter what, the apparent properties or latent properties will all be considered comprehensively. Thus, the implicit properties for the requirements can be obtained. According to the implicit properties, the "hypostatic characteristics" for the requirements will be derived and confirmed.

*Step 5.* Solve design problems by using conjugate properties and transformation operation of the elements of "hypostatic characteristics."

According to the requirements of potential function of product, we modify the concepts of design through transformation processes, and thus the new product  $N$  possesses the required potential function. Besides, considering the negative value of functional part of product  $N$ , negative part of  $N$   $ng(c)N$ , and the concept can be modified by transform operation to reduce negative effects.

*Step 6.* Repeat the above processes to achieve a number of programs of product  $N$  to develop and expand the concepts of product.

Use basic transformations on the matter element and the transform operation to achieve a variety of new product ideas. The Following is the operation:

$$TR = \prod_{i=1}^n (T_i R_i) = \prod_{i=1}^n \prod_{j=1}^m (T_{ij} R_{ij}). \quad (8)$$

#### 4. Design Evaluation

By using the extensive properties of matter element, many concept design solutions can be obtained. These possible solutions should be checked or evaluated, to filter out as the optimal solutions. Rhombus thinking model is the core method while proceeding optimal innovative design. As shown in Figure 2, "rhombus thinking" is a creative thinking method which diverges first and converges later. The convergent part of Rhombus thinking model is the procedure of evaluation for decision making.

Wang and Zhao, 1998 indicated that "authenticity message discriminant method" and "fuzzy convergence" are feasible extensive decision-making methods. In this paper, an evaluation method has been developed based on HOQ of QFD and Robust design methods [9]. In HOQ, ECs are a list of relevant design characteristics. The absolute importance of ECs can be computed by integrating both the final importance of CRs and the relationship matrix. The corresponding weighting coefficients can be determined based on the weighting values of absolute importance of ECs.

Let  $S = \{S_1, S_2, \dots, S_n\}$  be the feasible design solution obtained by extensive innovation, and the corresponding evaluation indices are defined as characteristic set  $C = \{C_1, C_2, \dots, C_n\}$ ; the following is the matter-element model for feasible solutions:

$$R_i = (S_i, C, V_i) = \begin{bmatrix} S_i & C_1 & V_{i1} \\ & C_2 & V_{i2} \\ & \vdots & \vdots \\ & C_n & V_{in} \end{bmatrix} \quad (i = 1, 2, \dots, n), \quad (9)$$

where  $V_i = \{V_{i1}, V_{i2}, \dots, V_{in}\}$  are the corresponding values of indices  $C = \{C_1, C_2, \dots, C_n\}$  which are determined by experts referring to the feasible solutions. Let the ideal design proposal given by experts express as

$$R^* = (S^*, C, V) = \begin{bmatrix} S^* & C_1 & V_1 \\ & C_2 & V_2 \\ & \vdots & \vdots \\ & C_n & V_n \end{bmatrix}, \quad (10)$$

where  $V_j = (V^* - \delta_j, V^* + \delta_j)$  are the value intervals referring to indices  $C_j$ .

Based on the definition of loss function of Taguchi method, three characteristics are used to define the criteria of evaluation. The proposed criteria are "nominal-the-best," "smaller-the-better," and "larger-the-better." The following is the definition of dependent function for each required criteria.

(a) *Nominal-the-Best.* As  $V^*$  is the value corresponding to characteristic of ideal design, the dependent function of criteria for "nominal-the-best" can be defined as

$$K(V_j) = \begin{cases} \ln \frac{\delta_j}{|V_j - V^*|} & V^* - \delta_j \leq V_j \leq V^* + \delta_j \\ 0 & \text{others.} \end{cases} \quad (11)$$

(b) *Smaller-the-Better.* The dependent function of criteria for "smaller-the-better" can be defined as

$$K(V_j) = \ln \frac{\text{Max } V_j - \text{Min } V_j}{V^* - \text{Min } V_j}. \quad (12)$$

(c) *Larger-the-Better.* The associated dependent function of criteria is defined as

$$K(V_j) = \ln \frac{\text{Max } V_j - \text{Min } V_j}{\text{Max } V_j - V^*}. \quad (13)$$

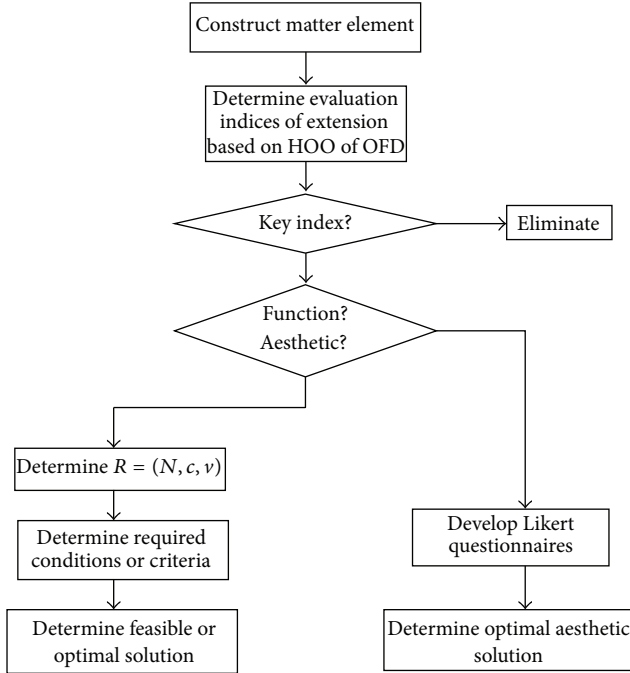

FIGURE 3: Flowchart of evaluation.

The dependent degree between proposed design and ideal design can be calculated by the formula presented above. The flowchart of comprehensive evaluation for the proposed extensive innovation procedure has been presented in Figure 3. There are no explicit formulae for certain characteristics to be evaluated. Aesthetic is the typical characteristic which cannot be evaluated by certain formula. A psychometric scale, Likert scale, is a common suggestion that employs questionnaires to scoring and analyzing the characteristic. Respondents assign their level of agreement or disagreement on a symmetric agree-disagree scale for a series of statements while responding to a Likert questionnaire item. Therefore,

the range catches the intensity of their feelings for a given item. Over the entire range of the scale, a scale can be defined as the simple sum questionnaire responses. Thus, in this research, we suggest that the dependent function for characteristics refers to uncertain scales can be defined as the sum of Likert questionnaire responses.

### 5. Illustrative Design Case

In this research, design case “bicycle”, the most favorite exercise equipment and transported is adapted to explain and verify feasibility of the proposed innovative procedure. The proposed approach, QFD integrated with extension method, has been used to investigate the users’ needs and relative functional requirements. In the creative course, we make use of the extension method to improve product design attributes and to determine the associated engineering design parameters. The creative solution programs based on customers’ voice will thus be achieved.

5.1. Extensive Processes. Two parts are in this stage of research. First, obtain the needs of bicycle by interviewing the elderly and translate them into product design attributes, and then in the second part, the questionnaire checks for the elderly to pick the important requirements.

In this study, survey candidates are the cycling sport amateurs. In order to avoid some important problems being ignored, the cyclists are included. Gathering respondents’ views and users’ requirements are sorted out as Table 1.

Use extending tree method to assist the establishment of HOQ. First, we build the transformation model by extending tree: a matter refers to multicharacteristics; a characteristic is also mapped by matters. Thus, “one matter with multicharacteristics”, “one characteristic maps to multimatters”, “one value maps to multimatters”, “one matter, one value versus multicharacteristics”, “one matter, one characteristic versus multivalues” are the extending propositions of matter element to resolve contradiction.

$$\begin{aligned}
 R_1 &= \left[ \begin{array}{c|c} \text{Overall riding comfortable} & \begin{array}{l} \text{comfortable grip} \\ \text{anti-shock} \\ \text{comfortable saddle} \\ \text{ventilatory saddle} \end{array} \\ \cdot & \\ \cdot & \\ \cdot & \end{array} \right] \\
 R_2 &= \left[ \begin{array}{c|c} \text{Portability operating} & \begin{array}{l} \text{Light weight} \\ \text{Breaking effort} \\ \text{Operate derailleur smoothly} \\ \text{Chain-link come off the ratchet} \\ \text{and slip gears} \end{array} \\ \text{experience} & \\ \cdot & \\ \cdot & \\ \cdot & \end{array} \right] \\
 R_3 &= \left[ \begin{array}{c|c} \text{Flexible adjustment} & \begin{array}{l} \text{Easy to adjust seat post} \\ \text{Quick detach} \end{array} \end{array} \right],
 \end{aligned} \tag{14}$$

and so forth.

We can translate product functional requirements into product design attributes as shown in Table 2.

We derive and confirm the “hypostatic characteristics” from “functional characteristics” and then the corresponding “certain characteristics” will also be derived and confirmed.

TABLE 1: Requirements of bicycle for the sport amateurs.

Portability operating experience
Overall riding comfortable
Cost/price
Flexibility to adjust
Sturdy and durable
Additional functions
Attractive appearance

Then, we use the corresponding four pairs of transformation methods to describe the composition of matters and assist the transformation and extension of matter-elements. For the iso-matter-element, we can use replacement, addition/deletion, expansion/contraction but for the distinct matter-element the applicable methods are addition/deletion, expansion/contraction transformation.

Take the design attributes, (ergonomic, handling, and convenient to pump up tires) and (ergonomic, comfort, and stability of tire pressure), for example. One of the Customers' complaints is that low tire pressure will result in large resistance riding; however, the high tire pressure can easily lead to a puncture or unstable riding. Customers' complaint pointed out that tire pressure seriously affects traffic safety. How to maintain the stability of tire pressure is a noteworthy design problem.

The extension of relationship element of pumping is

$$Q = \begin{bmatrix} \text{Pumping} & \text{Perform type} & \text{Hand pressed} \\ & \text{Air compressed type} & \text{Reciprocating} \\ & \text{Tire type} & \text{Air tire} \\ & \text{Tire pressure control} & \text{No} \\ & & \dots \\ & \vdots & \vdots \end{bmatrix}$$

$$= (s, A, W).$$

(15)

First, we conclude that customers' demands for bicycle tire are safety and comfort. Pumping device is expected to be light and handy. Stable tire pressure device, the customers' demand, indicates two needs "pressure compression" and "pressure relief." Therefore, autopumping system, the latent demand for customers, can be deduced by extensible QFD proposed in this paper.

We consider making the "autopumping device" play the major role of bicycle devices and then design problem becomes "how to pump air into tire during the riding process?" And "how to release pressure while overpumping?" This leads to new design problems based on the new concept. Repeat matter-element extending program and rhombus thinking procedure. Transform the pump device into a new general model by the divergence tree. Therefore, many ideas will be obtained. One of the obtained ideas is using shock absorbers in a suspension system. Shock absorbers usually

TABLE 2: Product design attributes.

Level 1	Level 2	Level 3
Basic function	Specifications	Simplify parts
		Design for assembly
		Weight
	Mechanism	Size
		Driving mechanism
		Breaking mechanism
		Derailleur mechanism
	Safety	Material of frame
		Maintenance
		Breaking performance
Ergonomic	Comfort	Structural strength
		Heat dissipation of saddle
		Suspension performance
		Body dimensions
		Stability of tire pressure
	Handling	Derailleur maneuverability
		Flexible adjustment
		Brake system
		Convenient to pump up tires

consists of two parts: a spring and a damper. The shock absorbers can be redesigned to form the pumping device. The new device, autopumping device as shown in Figure 4, can meet the demand. Rotary compression pump which was placed in the rotary axis of tire is another design example. Therefore, many ideas can be obtained with the help of the extensive QFD. We propose changing the pumping procedure. Autopumping device will be the new design concept we proposed.

Another design case proposed is "wheelchair." We obtained the needs of wheelchair by interviewing the elderly in nursing home and the nurse aides with long experience. Users' requirements are sorted out as Table 3. Thus, "harmful side effects," one of the 39 engineer parameters of TRIZ is what we concerned. We take the "harmful side effects" as the matter-element. By processing the extensive QFD, we try to transform "harmful side effects" to "beneficial side effects." For the elderly, long time in a wheelchair leads to "poor blood circulation" which is one of the "harmful side effects." Thus, a series of cyclic-motion for pedal, such as wave-like motion or vibration type of paddle, seem to be the answer to avoid "poor blood circulation."

## 6. Conclusions

This study proposes an innovative design and problem-solving process, based on quality function deployment method integrated with extension of matter element. Customers' needs and the priorities of product characteristics can be identified by QFD. This paper proposed the procedure of extensible QFD to transform product functional requirements into engineering design parameters. With the help of

TABLE 3: Requirements of wheelchair for the elderly.

Operation to be effort
Comfortable
Easy to keep clean
Flexibility to adjust
Sturdy and durable
Convenience to get in (off) wheelchair
Additional functions

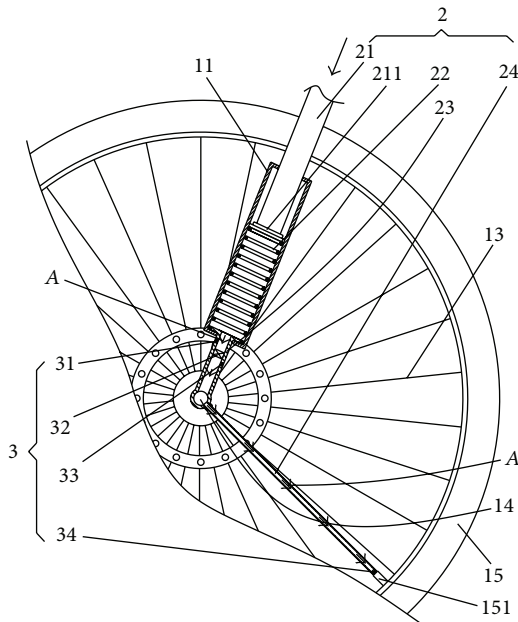

FIGURE 4: Autopumping device.

extension theory, the design proposals can be obtained more widely.

Besides, the evaluation dependent functions for design criteria based on the concepts of Taguchi method have also been proposed. As for the psychological characteristics, Likert questionnaire and scale are suggested to score and analyze such characteristics. Likert scale maybe just a simple measurement method. However, it can provide another way of design evaluation for psychological viewing. Kansei engineering, developed by Mitsuo Nagamachi, aims at the development or improvement of products and services by translating customer's psychological feelings and needs into product's design domain. The authors pay attention to Kansei engineering and hope. The authors pay attention to Kansei engineering and expect to develop another way for evaluation in the future can develop another way for evaluated in the future.

We assess the possibility and advantages to combine quality function deployment with the extension of matter elements. An innovative design case, bicycle, demonstrates the proposed design process. "Convenient to pump up tires" and "stability of tire pressure" are the customers' requirements obtained from the QFD process. By processing the extensible

QFD, autopumping system with overpressure relief device, the latent demand for customers has been deduced. The innovative concept design of "autopumping" demonstrated in this paper won the "IF award" in 2012.

## Acknowledgment

This work is supported by the National Science Council, Taiwan, no. NSC 95-2221-E-017-006.

## References

- [1] E. K. Delice and Z. Güngör, "A new mixed integer linear programming model for product development using quality function deployment," *Computers and Industrial Engineering*, vol. 57, no. 3, pp. 906–912, 2009.
- [2] A. Hill, "Quality function deployment," in *Gower Handbook of Quality Management*, D. Lock, Ed., chapter 21, pp. 364–386, Gower, Brookeld, Vt, USA, 2nd edition, 1994.
- [3] L. P. Sullivan, "Quality function deployment," *Quality Progress*, vol. 19, no. 6, pp. 39–50, 1986.
- [4] L. P. Sullivan, "The seven stages in company-wide quality control," *Quality Progress*, vol. 19, no. 5, pp. 77–83, 1986.
- [5] C. Garibay, H. Gutiérrez, and A. Figueroa, "Evaluation of a digital library by means of quality function deployment (QFD) and the Kano model," *Journal of Academic Librarianship*, vol. 36, no. 2, pp. 125–132, 2010.
- [6] W. Cai, C. Y. Yang, and W. C. Lin, *Extensive Engineering Method*, Science Press, Beijing, China, 1997.
- [7] Y. Akao, *Quality Function Deployment: Integrating Customer Requirements into Product Design*, Productivity Press, Cambridge, Mass, USA, 1990.
- [8] T. C. Kuo and W. Hsin-Hung, "Fuzzy eco-design product development by using quality function deployment," in *Proceedings of the 4th International Symposium on Environmentally Conscious Design and Inverse Manufacturing (Eco Design '05)*, pp. 422–429, Tokyo, Japan, December 2005.
- [9] W. L. Wang and Y. W. Zhao, "Explore the extensive decision-making of mechanical intelligent CAD," *System Engineering Theory and Practice*, vol. 18, no. 2, p. 114, 1998.
- [10] C. T. Wu, J. R. Chou, and C. S. Wu, "An extensive innovation procedure to quality function deployment for product design," in *Proceedings of the IEEE 19th International Conference on Industrial Engineering and Engineering Management*, pp. 688–692, 2012.
- [11] C. Y. Yang and B. He, "Application of extension method in new product concept," *System Engineering Theory and Practice*, vol. 19, no. 3, p. 120, 1999.
- [12] Y. C. Lee, L. C. Sheu, and Y. G. Tsou, "Quality function deployment implementation based on Fuzzy Kano model: an application in PLM system," *Computers and Industrial Engineering*, vol. 55, no. 1, pp. 48–63, 2008.

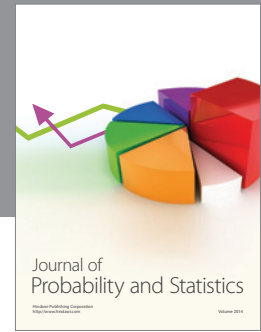
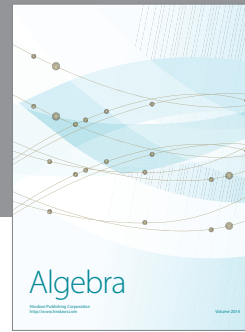
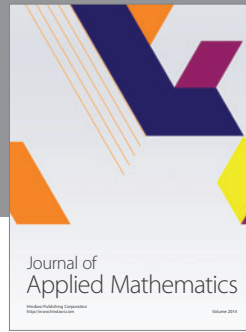
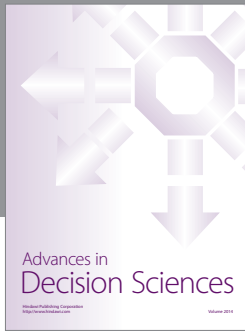

# Hindawi

Submit your manuscripts at  
<http://www.hindawi.com>

