

A pericentric inversion of chromosome 4 in pigs

A Ducos¹, A Pinton¹, A Séguéla¹, HM Berland¹, MF Blanc¹,
A Darré², P Pinton³, M Yerle³, R Darré¹

¹ *Ura Inra-ENVT de cytogénétique des populations animales, École nationale vétérinaire, 23, chemin des Capelles, 31076 Toulouse cedex;*

² *École nationale de formation agronomique, Service de zootechnie, 31326 Castanet-Tolosan cedex;*

³ *Laboratoire de génétique cellulaire, Institut national de la recherche agronomique, Auzeville BP 27, 31326 Castanet-Tolosan cedex, France*

(Received 11 December 1996; accepted 16 May 1997)

Summary – The main French porcine artificial insemination centre recently decided to carry out a systematic chromosomal evaluation of the animals used for pure-breeding purposes. This practice has allowed the identification of a new pericentric inversion affecting chromosome 4, in four Large White boars originating from four different herds. The cytogenetic evaluation by means of the GTG-banding technique revealed an inversion of the pericentric part of the chromosome, after double breaks, the first one in the 4q2.3 pale band of the long arm, and the second one in the upper border of the 4p1.4 dark band of the short arm. The chromosomal rearrangement could be described, according to the standard nomenclature, as 38,XY,inv(4)(p14q23). This interpretation has been confirmed by in situ hybridization of the cosmid BHT12 located on the 4p1.5 band. This chromosomal abnormality has no significant effect on production or reproductive performance of carrier animal. A rather old and common origin of the abnormality is hypothesized.

chromosome aberration / pericentric inversion / pig / reproductive performance / FISH

Résumé – **Inversion péricentrique du chromosome 4 chez le porc.** *Le principal centre français d'insémination artificielle porcine a récemment décidé de procéder à un contrôle chromosomique systématique de tous les verrats de races pures. Cette pratique a permis de mettre en évidence, chez quatre verrats Large White issus de quatre élevages de sélection différents, une nouvelle inversion péricentrique impliquant le chromosome 4. L'examen des chromosomes colorés en bandes GTG a révélé une double cassure, la première au niveau de la bande claire 4q2.3 du bras long, la seconde en limite supérieure de la bande sombre 4p1.4 sur le bras court, suivie d'une inversion de la partie péricentrique du chromosome. Cette anomalie peut être décrite, conformément à la nomenclature en vigueur, de la façon suivante : 38,XY,inv(4)(p14q23). Cette interprétation a été confirmée grâce à l'hybridation in situ du cosmide BHT12 localisé au niveau de la bande 4p1.5. Cette*

anomalie chromosomique n'a pas d'effet significatif sur les performances de production ou de reproduction des individus porteurs. Une origine commune et relativement ancienne est envisagée.

anomalie chromosomique / inversion péricentrique / porc / performances de reproduction / FISH

INTRODUCTION

Peri- or paracentric inversions are chromosomal abnormalities relatively frequent and particularly well known in humans. Individuals heterozygous for the inversion can produce unbalanced gametes (duplications, deletions) leading to non-viable embryos (hence to a lower fertility of the carriers) or to more or less marked phenotypic modifications of the viable embryos with an unbalanced karyotype: facial alterations, mental retardation; see for example Madan (1995) and Villa et al (1995).

Such abnormalities have also been described in other animals but much less frequently. The first cases of pericentric inversion in cattle were reported as early as the late sixties (Short et al, 1969). In most situations, the identified inversions were associated with an important loss of fertility (Popescu, 1972, 1976; Roldan et al, 1984; Switonski, 1987; Guo and Chen, 1989). In the porcine species, the first case of an inversion was reported quite recently (Switonski, 1991): a paracentric inversion of chromosome 8. Since then, two different pericentric inversions, both affecting chromosome 1, have been observed (Miyake et al, 1994; Danielak-Czech, 1996). In both cases, the inversion seemed to have no effect on the fertility of the carriers, nor were phenotypic abnormalities detected in the carriers or in their offspring.

In contrast to inversions, reciprocal translocations are relatively frequent in the pig. Until now, more than 60 cases have been described (Ducos et al, 1997). Those translocations generally have a large effect on fertility. For this reason, the main French porcine artificial insemination centre recently decided to carry out a systematic chromosomal evaluation of the animals used for pure-breeding purposes (about 200 analyses per year). This practice has allowed the identification of boars carrying a new pericentric inversion affecting chromosome 4. The origin, the distribution and the zootechnical effects of this chromosomal abnormality are presented and discussed.

MATERIAL AND METHODS

Animals

The first carriers of the inversion were purebred Large White boars ([1] and [2] in fig 1) originating from two different selection herds. Samples of blood and/or skin biopsies were taken from two generations of offspring of boar [1], as well as on the parents of boar [2]. The abnormality was then diagnosed again in karyotypes of two other boars of the same breed ([3] and [4] in fig 1) originating from two other selection herds.

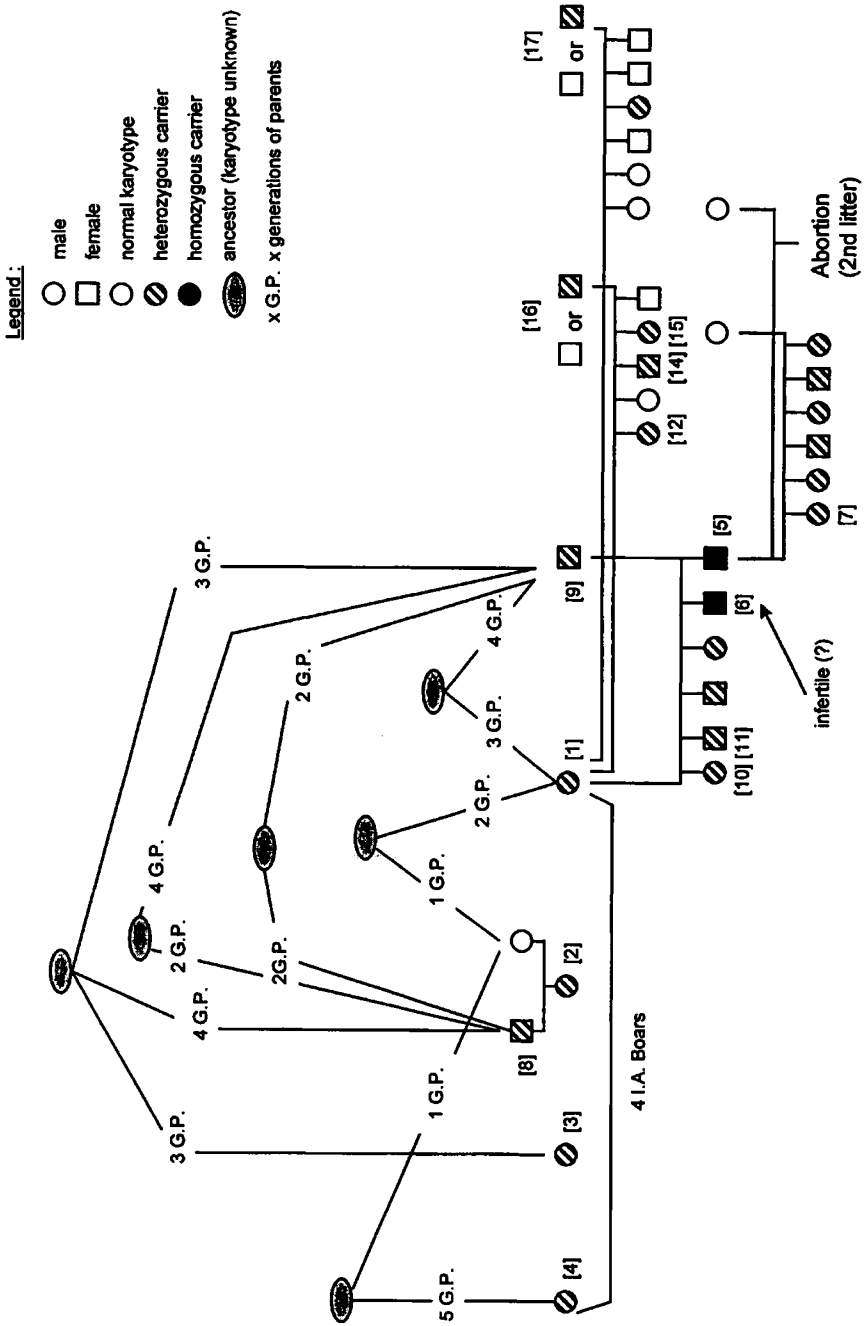

Fig 1. Relationship between the carrier animals.

Chromosomal study

The mitotic chromosomes were obtained from classical synchronized cultures of lymphocytes and fibroblasts. Chromosome preparations were spread on cold wet slides and air dried. Slides were treated with 0.1% trypsin (Difco) and stained with 3% Giemsa solution to generate GTG-banding (Seabright, 1971). The FPG technique previously described for humans (Dutrillaux and Couturier, 1981): BrdU incorporation during the last 7 h, was carried out to obtain RBG-banding patterns. Chromosomes were arranged according to the standardized karyotype of the domestic pig (Committee for the Standardized Karyotype of the Domestic Pig, 1988).

A fluorescent in situ hybridization was also performed in order to confirm the results obtained with classical cytogenetic methods. The procedure applied has previously been described by Yerle et al (1994). The GTG-banded chromosomes were hybridized with cosmid BHT12 (Hoyheim et al, 1994) located on the 4p1.5 band. The chromosomes were counter-stained with propidium iodide, examined under a Zeiss Axiophot microscope, and then photographed with a Fuji 400 film.

Zootechnical study

Production performance (age at 100 kg, backfat thickness at 100 kg) and reproductive performance (total number of piglets born) of the animals appearing in figure 1 (numbered animals) have been recorded within the national performance testing programme set up in France for genetic evaluation purposes (Ducos et al, 1994).

Analyses of variance were performed in order to compare performance of carrier and non-carrier animals. Production performance data were analysed using a linear model including the fixed effects of the batch (a batch was defined within each herd as a group of at least 15 animals of the same sex born within a 2-week period of time and tested at the same time) and of the inversion (normal or inverted chromosome 4). The reproductive performance of boars was also analysed using a linear model including the following fixed effects: inversion (normal or inverted chromosome 4), boar nested within inversion, herd \times year \times season \times type of fertilization combination (contemporary group) and parity number. Performance of all sows sired by boars that were carriers of the inversion, and performance of contemporary sows sired by normal boars were considered.

The effects of the inversion carried in a homozygous state could not be tested statistically owing to the very low number of homozygous animals (only two sows).

RESULTS

Chromosomal study

All the metaphases obtained (from lymphocytes or fibroblasts) for the first two boars [1] and [2] presented a peculiar appearance of chromosome 4. The structure of the other chromosomes was normal (fig 2). On the short arm of the abnormal chromosome 4, the presence of two dark bands in addition to the thin dark band in 4p1.2 was observed. We also observed the disappearance of the 4q2.4 dark band at the end of the long arm. The band structure of the central part of the chromosome

was not modified. Double breaks, the first one in the 4q2.3 pale band of the long arm, and the second one in the upper border of the 4p1.4 dark band of the short arm, followed by an inversion of the pericentric part of the chromosome were hypothesized (fig 3). The chromosomal rearrangement could be described, according to the standard nomenclature, as 38,XY,inv(4)(p14q23). The same abnormality was observed again in the dam of boar [2], as well as in boars [3] and [4]. The karyotypes of 17 offspring of boar [1], produced by mating this boar to three different dams, were prepared. All six offspring of the first dam ([9] in fig 1) carried the abnormality. Two of them (females [5] and [6] in fig 1) were homozygous for the inversion. Three piglets out of five, and one out of six, produced by females [16] and [17], respectively, carried the inversion (not all the piglets born in the litters shown in fig 1 could be karyotyped for reasons beyond our control). The homozygous sow [5] was mated and produced two successive litters. All six piglets born in the first litter carried the inversion. The second pregnancy was not finalized (abortion), for unknown reasons.

Hybridized to normal metaphases, the cosmid BHT12 marks the extremity of both chromosomes 4 with a double spot in the 4p1.5 region. The same cosmid hybridized to metaphases of an individual heterozygous for the inversion induces the same signals in the 4p1.5 region of the normal chromosome, and a double spot on the telomeric region of the long arm of the inverted chromosome (fig 4).

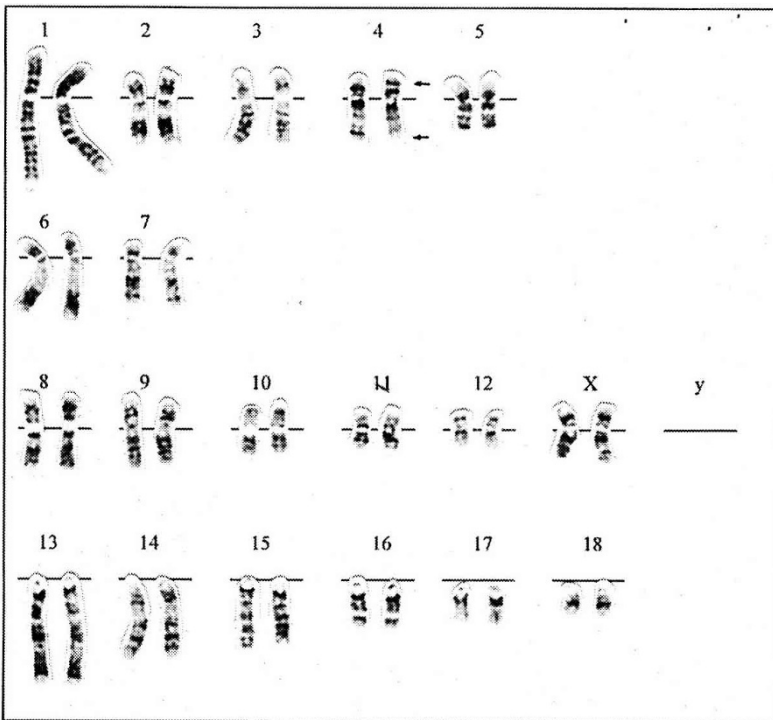

Fig 2a. GTG-banded karyotype of a sow heterozygous for the inversion.



Fig 2b. GTG-banded karyotype of a sow homozygous for the inversion.

Zootechnical study

Production performance of the inversion carriers controlled on the farm or in the station are indicated in table I. The performance of ten carriers out of 13, and 12 carriers out of 13, respectively, are slightly better than the average performance of their contemporaries (age at 100 kg and backfat thickness at 100 kg). However, the differences between carrier and non-carrier animals were not statistically significant.

The number of litters produced by each of the four boars ([1] to [4] in fig 1), and the average size of these litters are reported in table II. The boar [1] produced a rather large number of litters. The average litter size sired by this male was slightly higher (+ 0.8 piglets) than the average size of the litters produced by the other boars during the same period in the same herds. However, the effect of the inversion on reproductive performance of boars was not statistically significant. The fertility records of sow-carriers are given in table III. The successive litters of the sows heterozygous for the inversion (sows [8] and [9] in fig 1) had a normal size (more than ten piglets). The sow [6], homozygous for the inversion, could not be fertilized after three successive cycles of artificial insemination. The breeder stated that it was sterile and proposed culling. Sow [5], also homozygous, had a first litter of six piglets, one of them presenting serious malformations (animal [7] in fig 1). The second gestation of this sow was confirmed but was not finalized.

The genealogies of the carriers were reconstructed over five generations. Many ancestors common to these animals were identified (fig 1).

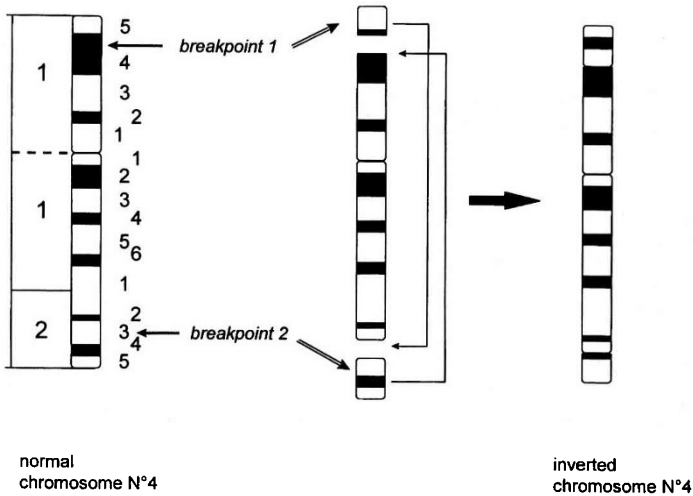

Fig 3. Schematic representation of the GTG-banded normal and inverted chromosome 4.

DISCUSSION

Among livestock animals, the porcine species is probably the one in which the greatest number of structural chromosomal abnormalities have been identified. The reciprocal translocations have been and still are intensively investigated owing to their deleterious effect on prolificacy, the major component of the current French selection objective (Ducos, 1995). Thus, most of the translocations have been identified in animals with a low prolificacy (Popescu and Boscher, 1986). The first translocations described involved rather large chromosome segments, and thus could be detected with routine Giemsa stain techniques. The peri- or paracentric inversions identified in the pig until now concerned rather small-sized chromosomal segments and seemed to have no effect on reproductive performance. For these reasons, the detection of such abnormalities requires a systematic survey of populations using the most elaborate cytogenetic techniques (high resolution banding techniques). This strategy has been developed in France. Today, all purebred boars of the main porcine artificial insemination centre, and of one of the three most important selection groups, are examined chromosomally before they are put into service. A generalization of this practice to all French breeding organizations is considered essential and should allow us to complete, in the near future, the current (very short) list of identified inversions in the porcine species.

The pericentric inversion of chromosome 4 described in this paper has been identified independently in four Large White purebred boars, all originating from different herds. The existence of several ancestors common to these animals, and the apparent absence of zootechnical effects, lead us to think that the origin of the abnormality is rather old and restricted to a small number of animals, from which it spread considerably owing to the more and more intensive use of artificial insemination. This abnormality has not, so far, been found in the other breeds studied in our laboratory (French Landrace and Piétrain, mainly).

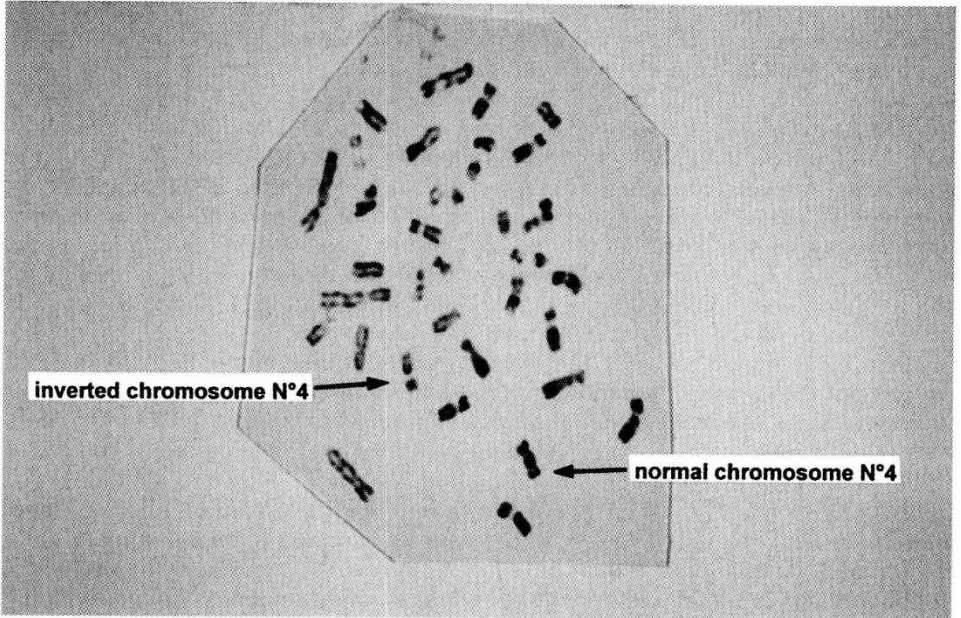
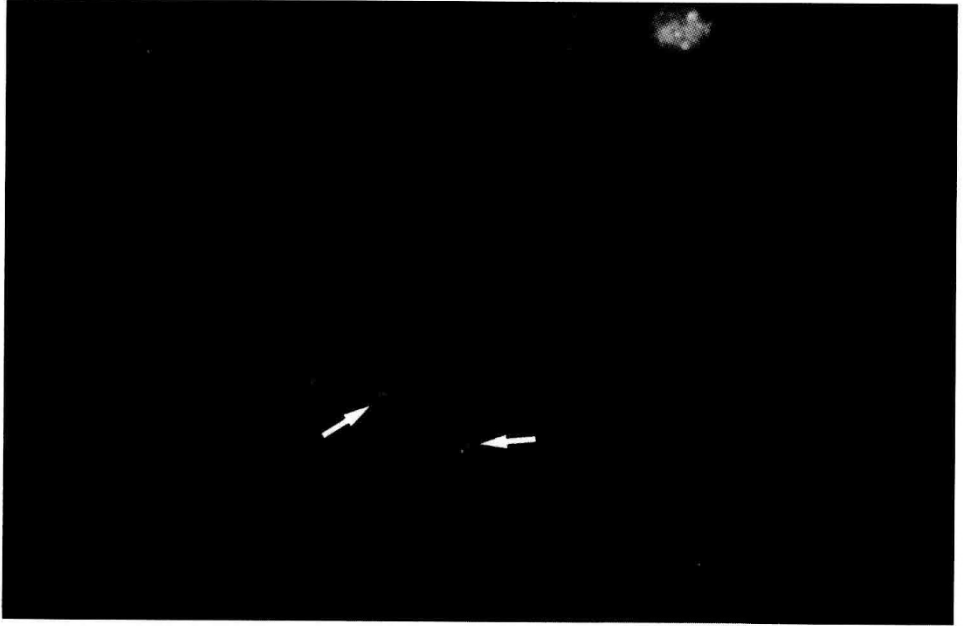

Fig 4. In situ hybridization of cosmid clone BHT12 on a metaphase heterozygous for the inversion.

The results shown in table I seem to indicate a slight favourable effect of the inversion, especially for the adiposity trait. Quantitative trait loci for growth and fatness in pigs have been recently identified on chromosome 4 (Andersson et al, 1994: the QTLs are linked to the markers S0001, S0107 and S0175, located on the pericentric part of the chromosome). The modification of the neighbourhood (of the regulation) of these genes induced by the inversion could perhaps explain the slight superiority of carrier animals. However, since the effect of the inversion is not statistically significant, this hypothesis should be considered very carefully.

The inversion has no significant effect on reproductive performance of sows sired by heterozygous boars. Owing to the very low number of homozygous carriers (only two sows), the effects of the inversion carried in a homozygous state could not be tested statistically. Although chance cannot be totally excluded in this matter, the results shown in table II lead us to contemplate an unfavourable effect of the abnormality in the homozygous females. This effect might be the result of a modification of the function of certain genes (Villa et al, 1995) that is due to a change in their neighbourhood (recessive modification: the environment of the genes of the two homologous chromosomes must be modified so that the effect is visible). This hypothesis could be tested experimentally by creating and mating new homozygous females. The karyotype analysis of a large sample of females presenting serious problems of reproduction might also allow demonstration of the role of this inversion, in a homozygous state, for certain reproductive impairments.

The fact that individuals heterozygous for the inversion have a normal fertility would seem to indicate that no, or a very small number of unbalanced gametes are produced by these animals. The same hypothesis was put forward in the case of the pericentric inversion of chromosome 1 reported by Miyake et al (1994) and contradicts the suppositions of Eldridge (1985) according to whom half the number of gametes produced by an individual heterozygous for the inversion carry duplications/deletions. A synaptonemal complex analysis demonstrated the absence of an inversion loop in a heterozygote for a paracentric inversion of chromosome 8 (Switonski, 1991). The heterologous pairing observed prevents crossing-overs inside the inverted segment and is followed by the formation of balanced gametes (Switonski, 1991). The absence of a loop can be explained by the small size of the inverted chromosome segment (Trunca and Opitz, 1977; Daniel, 1981; Kaiser, 1984), it is physically impossible to form a loop; this was the case for the inversion described by Switonski (1991). It can also be explained by the localization of the breakpoints (Ashley, 1988). According to Perdigo et al (1989) inversion loops would only form when the breakpoints are localized in G-negative (pale) bands. In the present case, the inversion involves a rather large chromosome segment, with breakpoints located, one in a G-negative band (4q2.3) and the other one at the border of a G-positive band (4p1.4), which might explain the absence of an inversion loop. This hypothesis will soon be experimentally tested by synaptonemal complex analyses.

The precise characterization of this abnormality with the help of classical cytogenetic techniques (non-molecular) is relatively difficult. The structural modification of chromosome 4 due to the inversion is a minor one, making its detection very difficult with routine Giemsa stain techniques, and also with the RBG-banding technique. Additionally, a careful examination is necessary to distinguish the inverted

Table I. On-farm production performance of the inversion carriers.

| <i>Animal No</i> | <i>Karyotype^a</i> | <i>A100^b</i> | <i>A100c^b</i> | <i>B100^b</i> | <i>B100c^b</i> |
|------------------|------------------------------|-------------------------|--------------------------|-------------------------|--------------------------|
| 1 | INV | 130.5 | 13.4 + | 9.6 | 0.3 + |
| 2 | INV | 133.0 | 5.3 + | 7.3 | 1.8 + |
| 3 | INV | 147.6 | 4.7 + | 11.7 | 0.6 + |
| 4 ^c | INV | 1013.4 | 84.8 + | 9.3 | 1.2 + |
| 5 | DBE | 161.7 | 0.6 + | 10.1 | 1.8 + |
| 6 | DBE | 149.1 | 13.2 + | 10.9 | 1.0 + |
| 8 | INV | 130.4 | 17.7 + | 13.0 | 1.8 - |
| 9 | INV or DBE | 159.7 | 2.8 - | 11.0 | 2.1 + |
| 10 | INV | 167.4 | 5.1 - | 10.0 | 1.9 + |
| 11 | INV | 159.4 | 2.9 + | 10.7 | 1.2 + |
| 12 | INV | 150.4 | 11.9 + | 10.3 | 1.6 + |
| 14 | INV | 166.1 | 3.8 - | 10.3 | 1.6 + |
| 15 | INV | 160.4 | 1.9 + | 10.9 | 1.0 + |

^a INV = heterozygous for the inversion; DBE = homozygous for the inversion.

^b A100 = age at 100 kg (days); B100 = average backfat thickness at 100 kg (mm); A100c or B100c = deviation from the contemporary group mean, ie, the average performance of pigs reared in the same batch (+ = favourable; - = unfavourable). ^c Station tested animal: A100 becomes average daily gain between 25 and 90 kg (g/day) and B100 becomes average backfat thickness at 90 kg.

Table II. Reproductive performance of the carriers.

| <i>Boar No</i> | <i>Number of litters</i> | <i>Average litter size</i> | <i>Average litter size of contemporary boars^a</i> |
|----------------|--------------------------|----------------------------|--------------------------------------------------------------|
| 1 | 61 | 12.4 | 11.6 |
| 2 | 3 | 10.3 | 12.7 |
| 3 | 3 | 14.0 | 12.0 |
| 4 | 8 | 10.9 | 11.9 |

^a Boars used in the same herds during the same period.

chromosome 4 from the normal chromosome 5 with GTG-banding (the band structure of the inverted chromosome 4 is rather similar to the one of chromosome 5 if the latter is turned upside down; the inverted chromosome 4 looks like a 5p+). In order to confirm the initially proposed interpretation (fig 3), the fluorescent in situ hybridization of probes marking the terminal extremities of both arms of chromosome 4 was programmed. Several probes were judged as potentially interesting: hybrids of the panel developed by Yerle et al (1996) and Robic et al (1996), and one cosmid, BHT12 (Hoyheim et al, 1994). The cosmid hybridizes to the extremity of the normal chromosome 4 short arm (band 4p1.5). The hybridization of this cosmid BHT12 provided perfectly clear results. The photos in figure 4 show without ambiguity the transfer from the end of the short arm of the inverted chromosome 4 to the end of the long arm, and confirm the interpretation formulated after the

Table III. Reproductive performance of sows heterozygous or homozygous for the inversion.

| <i>Sow No</i> | <i>Parity</i> | <i>Litter size</i> |
|------------------|---------------|--------------------|
| 5 (homozygous) | 1 | 6 |
| | 2 | abortion |
| 6 (homozygous) | infertile (?) | |
| 8 (heterozygous) | 1 | 15 |
| | 2 | 14 |
| | 3 | 16 |
| | 4 | 10 |
| | 5 | 11 |
| | | $\bar{x} = 13.2$ |
| 9 (heterozygous) | 1 | 14 |
| | 2 | 10 |
| | | $\bar{x} = 12.0$ |

cytogenetic observations. However, additional hybridizations will be made using other molecular probes (somatic cell hybrids) in order to support this hypothesis.

ACKNOWLEDGMENTS

We wish to express our gratitude to the staff of the insemination centre, of the selection organizations as well as the herd-stock breeders, for the blood-taking and all the arrangements concerning the animals. We also thank Dr Hoyheim for kindly providing the cosmid probe, and the reviewers for their helpful comments on the manuscript.

REFERENCES

- Anderson L, Haley CS, Ellegren H, Knott SA, Johansson M, Andersson K, Andersson-Eklund L, Edfors-Lija I, Fredholm M, Hansson I, Håkansson J, Lundström K (1994) Genetic mapping of quantitative trait loci for growth and fatness in pigs. *Science* 263, 1771-1774.
- Ashley T (1988) G-band position effects on meiotic synapsis and crossing over. *Genetics* 118, 307-317
- Committee for the standardized karyotype of the domestic pig (1988) Standard karyotype of the domestic pig. *Hereditas* 109, 151-157
- Daniel A (1981) Structural differences in pericentric inversions. Application to a model of risk of recombinants. *Hum Genet* 56, 321-328
- Danielak-Czech B, Kozubská-Sobocinska A, Słota E, Rejduch B, Kwaczynska A (1996) Preliminary identification of pair 1 chromosome rearrangement in a Polish Landrace sow. *Archivos de Zootecnia* 45, 215-219
- Ducos A (1995) Evolutions de l'objectif de sélection dans l'espèce porcine en France. Conséquences sur les progrès génétiques attendus. *Rev Med Vet* 146, 715-722
- Ducos A, Bidanel JP, Garreau H, Runavot JP (1994) Evaluation génétique des porcs à l'aide du modèle animal en France. In: Séminaire modèle animal, INRA, La Colle sur Loup, 26-29 septembre 1994, Inra, 119-141

- Ducos A, Berland H, Pinton A, Seguela A, Blanc MF, Darré A, Darré R (1997) Les translocations réciproques chez le porc: état des lieux et perspectives. In: *29èmes Journées de la Recherche Porcine en France*, Paris, 4–6 février 1997, Institut technique du porc, Paris, 29, 375–382.
- Dutrillaux B, Couturier J (1981) In: *La pratique de l'analyse chromosomique*. Masson Ed, Paris, 1981, 24–60
- Eldridge FE (1985) In: *Cytogenetics of Livestock*, AVI Publishing Company Inc, Westport, 1985, 39–42
- Guo AZ, Chen WF (1989) Chromosome abnormalities in infertile cows. *J Nanjing Agric Univ* 12, 66–70
- Hoyheim B, Keiserud A, Thomsen PD (1994) A highly polymorphic porcine dinucleotide repeat SO301 (BHT12) at chromosome 4p15. *Anim Genet* 25, 432
- Kaiser P (1984) Pericentric inversions. Problems and significance for clinical genetics. *Hum Genet* 68, 1–47
- Madan K (1995) Paracentric inversions: a review. *Hum Genet* 96, 503–515
- Miyake YI, Matsubara T, Hata M, Kaneda Y (1994) Chromosomal pericentric inversion detected in a sow and her piglets. *Theriogenology* 42, 241–246
- Perdigo A de, Gabriel-Robez O, Rumpler Y (1989) Correlation between chromosomal breakpoint positions and synaptic behaviour in human male heterozygous for a pericentric inversion. *Hum Genet* 83, 274–276
- Popescu CP (1972) Un cas possible d'inversion péricentrique chez les bovins. *Ann Genet* 15, 197–200
- Popescu CP (1976) New data on pericentric inversions in cattle (*Bos taurus* L.). *Ann Genet Sel Anim* 8, 434–448
- Popescu CP, Boscher J (1986) A new reciprocal translocation in a hypoprolific boar. *Genet Sel Evol* 18, 123–130
- Robic A, Riquet J, Yerle M, Milan D, Lahbib-Mansais Y, Dubut-Fontana C, Gellin J (1996) Porcine linkage and cytogenetic maps integrated by regional mapping of 100 microsatellites on somatic cell hybrid panel. *Mammalian Genome* 7, 438–445
- Roldan ERS, Meran MS, Lawzewitsch I (1984) Two abnormal chromosomes found in one cell line of mosaic cow with low fertility. *Genet Sel Evol* 16, 135–142
- Seabright M (1971) A rapid banding technique for human chromosomes. *Lancet* 2, 971–972
- Short RV, Smith J, Mann T, Evans ER, Hallett J, Fryer A, Hamerton JL (1969) Cytogenetic and endocrine studies of a freemartin heifer and its bull co-twin. *Cytogenetics* 8, 369–388
- Switonski M (1987) A pericentric inversion in an X chromosome in the cow. *J Hered* 78, 58–59
- Switonski M (1991) Paracentric inversion involving NOR of chromosome 8 in a boar: studies of synaptonemal complexes under a light microscope. *Genet Sel Evol* 23, 181–189
- Trunca C, Opitz JM (1977) Pericentric inversion of chromosome 14 and the risk of partial duplication of 14q(14q31-14qter). *Am J Med Genet* 1, 217–228
- Villa A, Urioste M, Carrascosa MC, Vasquez S, Martinez A, Martinez-Frias ML (1995) Pericentric inversions of chromosome 4: report of a new family and review of the literature. *Clin Genet* 48, 255–260
- Yerle M, Goureau A, Gellin J, Le Tissier P, Moran C (1994) Rapid mapping of cosmid clones on pig chromosomes by fluorescent in situ hybridization. *Mammalian Genome* 5, 34–37
- Yerle M, Echard G, Robic A, Mairal A, Dubut-Fontana C, Riquet J, Pinton P, Milan D, Lahbib-Mansais Y, Gellin J (1996) A somatic cell hybrid panel for pig regional gene mapping characterized by molecular cytogenetics. *Cytogenet Cell Genet* 73, 194–202