

Research Article

Stability of the Cauchy Additive Functional Equation on Tangle Space and Applications

Soo Hwan Kim

Department of Mathematics, Dong-eui University, Busan 614-714, Republic of Korea

Correspondence should be addressed to Soo Hwan Kim; sh-kim@deu.ac.kr

Received 18 July 2016; Accepted 9 October 2016

Academic Editor: Maria Bruzón

Copyright © 2016 Soo Hwan Kim. This is an open access article distributed under the Creative Commons Attribution License, which permits unrestricted use, distribution, and reproduction in any medium, provided the original work is properly cited.

We introduce real tangle and its operations, as a generalization of rational tangle and its operations, to enumerating tangles by using the calculus of continued fraction and moreover we study the analytical structure of tangles, knots, and links by using new operations between real tangles which need not have the topological structure. As applications of the analytical structure, we prove the generalized Hyers-Ulam stability of the Cauchy additive functional equation $f(x \oplus y) = f(x) \oplus f(y)$ in tangle space which is a set of real tangles with analytic structure and describe the DNA recombination as the action of some enzymes on tangle space.

1. Introduction

In 1970, Conway introduced rational tangles and algebraic tangles for enumerating knots and links by using Conway notation. The rational tangles are defined as the family of tangles that can be transformed into the trivial tangle by sequence of twisting of the endpoints. Given a tangle, two operations, called the numerator and denominator, by connecting the endpoints of the tangle produce knots or 2-component links. To enumerating and classifying knots, the theory of general tangles has been introduced in [1].

Moreover the rational tangles are classified by their fractions by means of the fact that two rational tangles are isotopic if and only if they have the same fraction [1]. This implies the known result that the rational tangles correspond to the rational numbers one to one. It is clear that every rational number can be written as continued fractions with all numerators equal to 1 and that every real number r corresponds to a unique continued fraction, which is finite if r is rational and infinite if r is irrational. Thus the continued fractions give the relationship between the analytical structure and topological structure under a certain restricted operator. See [2], for example. There are some operations that can be performed on tangles as the sum, multiplication, rotation, mirror image, and inverted image.

Topologically, the sum and multiplication on tangles are defined as connecting two endpoints of one tangle to two endpoints of another. However they are not commutative and do not preserve the class of rational tangles. Furthermore the sum and multiplication of two rational tangles are a rational tangle if and only if one of two is an integer tangle [3]. Thus the set of rational tangles is not a group because it was discovered that not all rational tangles form a closed set under the sum and multiplication. Considering a braid of rational tangles, a series of strands that are always descending, the set of braids is a group under braid multiplication.

In 1940, Ulam introduced the stability problem of functional equations during talk before a Mathematical Colloquium at the University of Wisconsin [4]:

Given a group G_1 , a metric group (G_2, d) and a positive number ϵ , does there exist a number $\delta > 0$ such that if a function $f : G_1 \rightarrow G_2$ satisfies the inequality $d(f(xy), f(x)f(y)) < \delta$ for all $x, y \in G_1$, there exists a homomorphism $T : G_1 \rightarrow G_2$ such that $d(f(x), T(x)) < \epsilon$ for all $x \in G_1$?

Analytically, the stability problem of functional equations originated from a question of Ulam concerning the stability of group homomorphisms. The functional equation

$$f(x + y) = f(x) + f(y) \quad (1)$$

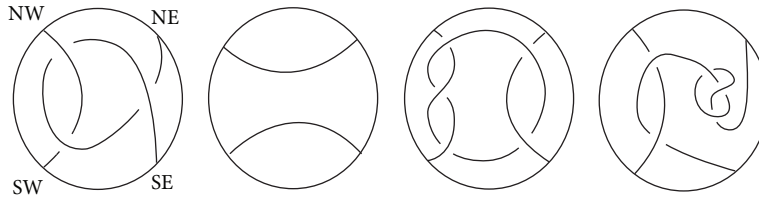

FIGURE 1: Rational, trivial, prime, locally knotted tangles.

is called the Cauchy additive functional equation. In particular, every solution of the Cauchy additive functional equation is said to be an additive mapping. In [5], Hyers gave the first affirmative partial answer to the question of Ulam for Banach spaces. In [6], Hyers' theorem was generalized by Aoki for additive mappings and by Rassias for linear mappings by considering an unbounded Cauchy difference in [7]. In [8], a generalization of the Rassias theorem was obtained by Găvruta by replacing the unbounded Cauchy difference by a general control function in Rassias' approach. There are many interesting stability problems of several functional equations that have been extensively investigated by a number of authors. See [9–14].

In recent years, new applications of tangles to the field of molecular biology have been developed. In particular, knot theory gives a nice way to model DNA recombination. The relationship between topology and DNA began in the 1950s with the discovery of the helical Crick-Watson structure of duplex DNA. The mathematical model is the tangle model for site-specific recombination, which was first introduced by Sumners [15]. This model uses knot theory to study enzyme mechanisms. Therefore rational tangles are of fundamental importance for the classification of knots and the study of DNA recombination. In this paper, we introduce new tangles called real tangles to apply the stability problem and DNA recombination on tangles.

In Section 2, we introduce real tangles and operations between tangles which can be performed to make up tangle space and having analytical structure. Moreover we show that the operations together with two real tangles will always generate a real tangle. In Section 3, we prove the Hyers-Ulam stability of the Cauchy additive functional equation in tangle space and study the DNA recombination on real tangles, as applications of knots or links.

2. Continued Fractions and Tangle Space

A rational tangle is a proper embedding of two unoriented arcs (strings) t_1 and t_2 in 3-ball B^3 so that the endpoints of the arcs go to a specific set of 4 points on the equator of B^3 , usually labeled NW, NE, SW, SE. This is equivalent to saying that rational tangles are defined as the family of tangles that can be transformed into the trivial tangle by a sequence of twisting of the endpoints. Note that there are tangles that cannot be obtained in this fashion: they are the prime tangles and locally knotted tangles. For example, see Figure 1.

Geometrically, we have the following operations between rational tangles: the integer (the horizontal) tangles, denoted

by $R(n)$, consist in n horizontal twists, $n \in \mathbb{Z}$, the mirror image of $R(n)$, denoted by $-R(n)$ or $R(-n)$, is obtained from $R(n)$ by switching all the crossing, and the rotation of $R(n)$, denoted by $R^R(n)$, is obtained by rotation $R(n)$ counterclockwise by 90° . Moreover the inverse (the vertical) tangle of $R(n)$, denoted by $R(1/n)$, is defined by $-R^R(n)$ or $R^R(-n)$ as the composition of the rotation and mirror of $R(n)$. For example, $R(1/3) = -R^R(3)$, and $R(1/-3) = -R^R(-3)$. For the trivial tangle $R(0)$ we define $R(\infty) = R^R(0)$ or $R(1/0)$.

Generally, every rational tangle can be represented by the continued fractions $C(a_1, a_2, \dots, a_n)$ as following Conway notation:

$$C(a_1, a_2, \dots, a_n) = a_1 + \frac{1}{a_2 + \dots + (1/(a_{n-1} + (1/a_n)))} \quad (2)$$

for $a_1 \in \mathbb{Z}$, $a_2, \dots, a_n \in \mathbb{Z} - \{0\}$, and n even or odd and we denote it by $R(a_1, a_2, \dots, a_n)$. See Figure 2.

By Conway [1], rational tangles are classified by fractions by fact of the following: two rational tangles are isotopic if and only if they have the same fraction. For example, $C(2, -2, 3)$ and $C(1, 2, 2)$ represent the same tangles up to isotopy because they have a fraction $7/5$. Therefore the rational tangles $R(a_1, a_2, \dots, a_n)$ with the exception of $\{R(0), R(\pm 1), R(\infty)\}$ are said to be in canonical form if $|a_n| > 1$, $a_i \neq 0$ for $2 \leq i \leq n$. Note that all nonzero entries have the same sign and every rational tangle has a unique canonical form. The canonical form of the example above is $R(1, 2, 2)$ and the following corollary, which is a direct result of Conway's theorem [1], will give us a means of classifying rational tangles by way of fractions.

Corollary 1. *There is a one-to-one correspondence between canonical rational tangles and rational numbers $\beta/\alpha \in \mathbb{Q} \cup \{\infty\}$, where $\alpha \in \mathbb{N} \cup \{0\}$, $\beta \in \mathbb{Z}$, $\gcd(\alpha, \beta) = 1$, $R(\infty) = R(1/0)$.*

Now we define infinite tangles by infinite continued fractions of irrational numbers that the chain of fractions never ends as the following:

$$C(a_1, a_2, a_3, \dots) = a_1 + \frac{1}{a_2 + (1/(a_3 + (1/(a_4 + \dots))))}, \quad (3)$$

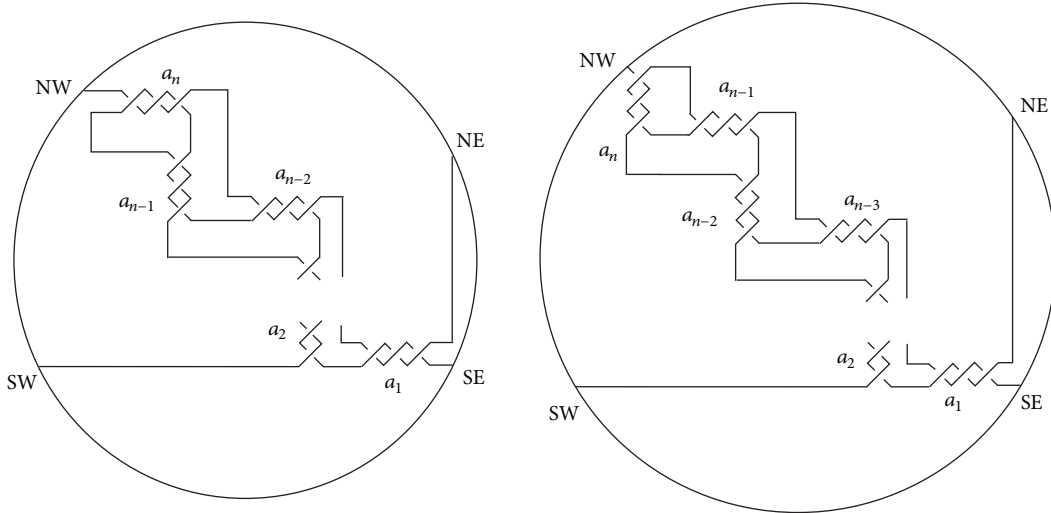

FIGURE 2: Rational tangles $R(a_1, a_2, \dots, a_n)$ for n odd or even.

where a_1 is allowed to be 0, but all subsequent terms a_i must be positive; that is, $a_1, a_2, \dots \in \mathbb{Z}$, $a_i > 0$ for $i \geq 2$. Note that let $C_i = C(a_1, a_2, \dots, a_i)$ for $i \geq 1$ and then the limit

$$C(a_1, a_2, a_3, \dots) = \lim_{i \rightarrow \infty} C_i \quad (4)$$

is a unique irrational number and that let $R_i = R(a_1, a_2, \dots, a_i)$ for $i \geq 1$ be canonical rational tangles and then the infinite tangles, denoted by $R(a_1, a_2, a_3, \dots)$, are defined by the limit of canonical rational tangles R_i as

$$R(a_1, a_2, a_3, \dots) = \lim_{i \rightarrow \infty} R_i. \quad (5)$$

Example 2. Let $C_1 = C(1), C_2 = (1, 1), \dots, C_i = C(1, 1, \dots, 1)$, and then the limit has an irrational number

$$\lim_{i \rightarrow \infty} C_i = C(1, 1, 1, \dots) = \frac{1 + \sqrt{2}}{2}. \quad (6)$$

Corollary 3. *There is a one-to-one correspondence between infinite tangles and irrational numbers.*

Note that $\alpha \in \mathbb{R} - \mathbb{Q}$ is quadratic irrational if and only if it is of the form

$$\alpha = \frac{a + \sqrt{b}}{c}, \quad (7)$$

where $a, b, c \in \mathbb{Z}$, $b > 0$, $c \neq 0$, and b is not the square of a rational number. Thus an irrational number is called quadratic irrational if it is a solution of a quadratic equation $Ax^2 + Bx + D = 0$, where $A, B, D \in \mathbb{Z}$ and $A \neq 0$. Moreover α is eventually periodic of the form

$$C(a_1, a_2, \dots, a_N, \overline{a_{N+1}, \dots, a_{N+p}}), \quad (8)$$

where the bar indicates the periodic part with p terms. Thus an infinite tangle is said to be periodic if it has eventually periodic of the form

$$R(a_1, a_2, \dots, a_N, \overline{a_{N+1}, \dots, a_{N+p}}). \quad (9)$$

See Figure 5 for $N = 1$ and $p = 2$.

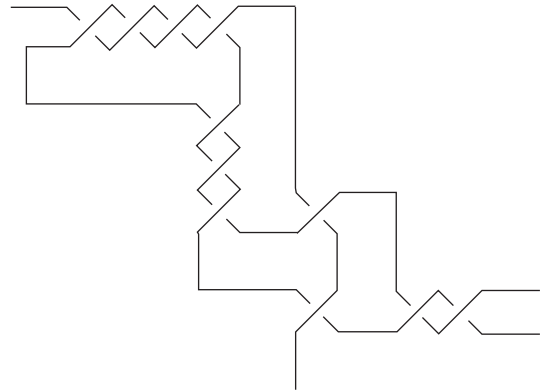

FIGURE 3: Canonical rational tangle $R(2, 1, 1, 3, 4)$.

Corollary 4. *There is a one-to-one correspondence between infinite periodic tangles and quadratic irrational numbers.*

Finally, tangles are said to be real if it is rational tangles or infinite tangles, and so the real tangles are finite if it is rational tangles and infinite if it is infinite tangles. Thus continued fractions of finite real tangles are rational and continued fractions of infinite real tangles are irrational. Moreover infinite real tangle is periodic if it is infinite periodic tangles, and so continued fractions of infinite periodic real tangles are quadratic irrational numbers. Let r be a real number that corresponds to finite or infinite continued fractions. Then, by corollaries, the fact that $R(r)$ has a unique real tangle can be proved. The following is examples of the corollaries above.

Example 5. (1) Let $77/30 \in \mathbb{Q}$ be a rational number. Then $R(77/30) = R(2, 1, 1, 3, 4)$ is a canonical rational tangle of $77/30$. See Figure 3.

(2) Let $e = 2.718281 \dots \in \mathbb{R} - \mathbb{Q}$ be an irrational number used as the base of the natural logarithm function. Then

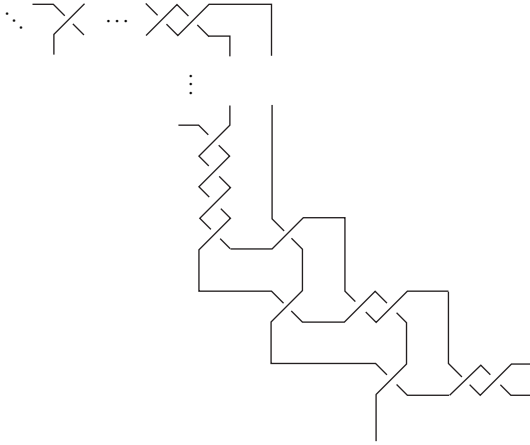
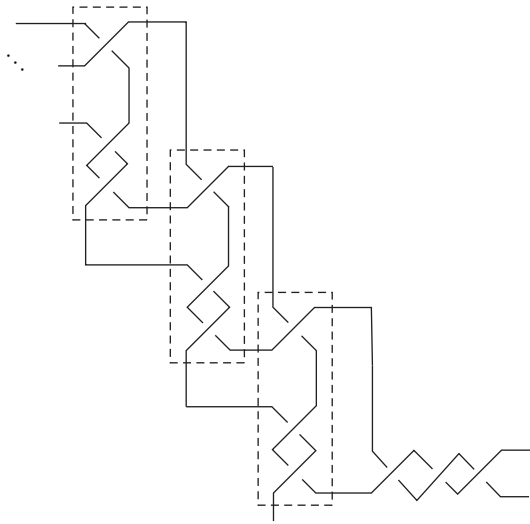
FIGURE 4: Infinite tangle $R(2, 1, 2, 1, 1, 4, \dots)$.FIGURE 5: Infinite periodic tangle $R(3, \overline{2}, 1)$.

$R(e) = R(2, 1, 2, 1, 1, 4, 1, 1, \dots)$ is an infinite tangle of e . See Figure 4.

(3) Considering a quadratic irrational number $(5 + \sqrt{3})/2$, $R((5 + \sqrt{3})/2) = R(3, 2, 1, 2, 1, \dots) = R(3, \overline{2}, 1)$ is an infinite periodic tangle of quadratic irrational number $(5 + \sqrt{3})/2$. See Figure 5. In Figure 5, the boxes mean periodic parts as $R(\overline{2}, 1)$.

Now we introduce the operations on real tangles with analytical structure, which need not have the topological structure. However, on rational tangles, our operations are applicable to geometrical results obtained from topological structure. Our operations need to discuss the generalized Hyers-Ulam stability of the Cauchy additive functional equation $f(x + y) = f(x) + f(y)$ and DNA recombinations in next section.

Let functions $p : R \times R \rightarrow R$, defined by $p(r_1, r_2) = r_1 + r_2$, and $m : R \times R \rightarrow R$, defined by $m(r_1, r_2) = r_1 \times r_2$ be two binary operators on R , and ϕ a map from the set of real tangles T to the set of real number R in which tangles $R(a_1, a_2, \dots, a_n)$ or $R(a_1, a_2, a_3, \dots)$ are corresponding to the

rational numbers or irrational numbers, respectively, one to one. Then for $\phi : T \rightarrow R$ and each tangles $t_1, t_2 \in T$, we define a map $\phi^* : T \times T \rightarrow R \times R$ by $\phi^*(t_1, t_2) = (\phi(t_1), \phi(t_2))$ and two binary operators \oplus and \otimes on a nonempty set T by

$$\begin{aligned} \oplus : T \times T &\longrightarrow T, \\ \otimes : T \times T &\longrightarrow T, \end{aligned} \quad (10)$$

where

$$\begin{aligned} \oplus(t_1, t_2) &= \phi^{-1} p \phi^*(t_1, t_2), \\ \otimes(t_1, t_2) &= \phi^{-1} m \phi^*(t_1, t_2). \end{aligned} \quad (11)$$

For convenience, we write $t_1 \oplus t_2$ and $t_1 \otimes t_2$ by $\oplus(t_1, t_2)$ and $\otimes(t_1, t_2)$, respectively.

Lemma 6. Let $\phi : T \rightarrow R$ be a map from the set of real tangles to the set of real numbers at which real tangles $R(a_1, a_2, \dots, a_n)$ or $R(a_1, a_2, \dots)$ are corresponding to the real number r , where r has continued fraction $C(a_1, a_2, \dots, a_n)$ or $C(a_1, a_2, \dots)$. Then ϕ satisfies the following properties: for all $t, t_1, t_2 \in T$,

$$\begin{aligned} (1) \quad &\phi(-t) = -\phi(t) \\ (2) \quad &\phi(-t^R) = \frac{1}{\phi(t)} \\ (3) \quad &t \oplus (-t) = R(0) \\ (4) \quad &t \otimes (-t^R) = R(1) \\ (5) \quad &\phi(t_1 \oplus t_2) = \phi(t_1) + \phi(t_2) \\ (6) \quad &\phi(t_1 \otimes t_2) = \phi(t_1) \times \phi(t_2). \end{aligned} \quad (12)$$

Proof. Let t be a real tangle in T and $\phi(t) = r \in R$, continued fraction corresponding to t .

(1) Since $-t$ is obtained from t by switching all the crossing, $\phi(-t) = -r$ and so $\phi(-t) = -\phi(t)$.

(2) Since t^R is obtained by rotation t counterclockwise by 90° , $\phi(t^R) = -1/r$ and so $\phi(-t^R) = 1/r$ by (1). Thus $\phi(-t^R) = 1/\phi(t)$.

(3) $t \oplus (-t) = \phi^{-1} p \phi^*(t, -t) = \phi^{-1} p(\phi(t), \phi(-t)) = \phi^{-1}(\phi(t) + \phi(-t)) = \phi^{-1}(0) = R(0)$ by (1).

(4) $t \otimes (-t^R) = \phi^{-1} m \phi^*(t, -t^R) = \phi^{-1} m(\phi(t), \phi(-t^R)) = \phi^{-1}(\phi(t) \times \phi(-t^R)) = \phi^{-1}(1) = R(1)$ by (2).

(5) $\phi(t_1 \oplus t_2) = \phi(\phi^{-1} p \phi^*(t_1, t_2)) = p(\phi(t_1), \phi(t_2)) = \phi(t_1) + \phi(t_2)$.

(6) $\phi(t_1 \otimes t_2) = \phi(\phi^{-1} m \phi^*(t_1, t_2)) = m(\phi(t_1), \phi(t_2)) = \phi(t_1) \times \phi(t_2)$. \square

In the following, we show that operators \oplus and \otimes together with two real tangles will always generate a real tangle.

Theorem 7. Let T be the set of real tangles and \oplus the binary operation on T . Then (T, \oplus) is a group.

Proof. To show associative of \oplus , let $t_1, t_2, t_3 \in T$.

Then

$$\begin{aligned}
(t_1 \oplus t_2) \oplus t_3 &= \phi^{-1} p \phi^* (\phi^{-1} p \phi^* (t_1, t_2), t_3) \\
&= \phi^{-1} p \phi^* (\phi^{-1} (\phi(t_1) + \phi(t_2)), t_3) \\
&= \phi^{-1} ((\phi(t_1) + \phi(t_2)) + \phi(t_3)) \\
&= \phi^{-1} (\phi(t_1) + (\phi(t_2) + \phi(t_3))) \quad (13) \\
&= \phi^{-1} p \phi^* (t_1, \phi^{-1} (\phi(t_2) + \phi(t_3))) \\
&= \phi^{-1} p \phi^* (t_1, \phi^{-1} p \phi^* (t_2, t_3)) \\
&= t_1 \oplus (t_2 \oplus t_3).
\end{aligned}$$

For the remainder, the identity element is the trivial tangle $R(0) \in T$ and the inverse of $t \in T$ is $-t$. See Lemma 6. Thus the set T forms a group with respect to \oplus . \square

In particular, for $t_1, t_2 \in T$, we write $t_1 \ominus t_2$ for $t_1 \oplus (-t_2)$.

Theorem 8. *Let T be the set of real tangles and \otimes the binary operation on T . Then (T, \otimes) is a group.*

Proof. To show associative of \otimes , let $t_1, t_2, t_3 \in T$. Then

$$\begin{aligned}
(t_1 \otimes t_2) \otimes t_3 &= \phi^{-1} m \phi^* (\phi^{-1} m \phi^* (t_1, t_2), t_3) \\
&= \phi^{-1} m \phi^* (\phi^{-1} (\phi(t_1) \times \phi(t_2)), t_3) \\
&= \phi^{-1} ((\phi(t_1) \times \phi(t_2)) \times \phi(t_3)) \\
&= \phi^{-1} (\phi(t_1) \times (\phi(t_2) \times \phi(t_3))) \quad (14) \\
&= \phi^{-1} m \phi^* (t_1, \phi^{-1} (\phi(t_2) \times \phi(t_3))) \\
&= \phi^{-1} m \phi^* (t_1, \phi^{-1} m \phi^* (t_2, t_3)) \\
&= t_1 \otimes (t_2 \otimes t_3).
\end{aligned}$$

For the remainder, the identity element is the integer tangle $R(1) \in T$ and the inverse of $t \in T$ is $-t^R$ and denoted as t^{-1} , where t^R means rotation counterclockwise by 90° . See Lemma 6. Thus the set T forms a group with respect to \otimes . \square

Corollary 9. *(T, \oplus) and (T, \otimes) are abelian groups.*

For the symbolization, we write nt for $t \oplus t \oplus \dots \oplus t$ (n summands) and write t^n for $t \otimes t \otimes \dots \otimes t$ (n products). Note that, by distributive law between two operations, we have

$$\begin{aligned}
(t_1 \oplus t_2) \otimes (t_3 \oplus t_4) &\iff \\
(t_1 \otimes t_3) \oplus (t_1 \otimes t_4) \oplus (t_2 \otimes t_3) \oplus (t_2 \otimes t_4). &\quad (15)
\end{aligned}$$

For $t_1, t_2, t \in T$ and $r \in R$, let $\oplus : T \times T \rightarrow T$ and $\cdot : R \times T \rightarrow T$ be addition and scalar multiplication operators, respectively, defined by $\oplus(t_1, t_2) = t_1 \oplus t_2$ and $\cdot(r, t) = \phi^{-1} m(r, \phi(t)) \in T$, denoted by $r \cdot t$, where $(\cdot, \cdot) : R \times T \rightarrow R \times R$ is a map. Then the set T of the real tangles with addition and scalar multiplication operators satisfy the following result.

Theorem 10. *(T, \oplus, \cdot) is a vector space.*

Proof. By Theorem 7, (T, \oplus) is a group. Moreover, we have the following properties:

$$\begin{aligned}
(1) \quad r \cdot (t_1 \oplus t_2) &= \phi^{-1} m(r, \phi(t_1 \oplus t_2)) \\
&= \phi^{-1} m(r, \phi \phi^{-1} p \phi^* (t_1, t_2)) \\
&= \phi^{-1} m(r, \phi(t_1) + \phi(t_2)) \\
&= \phi^{-1} (r \times (\phi(t_1) + \phi(t_2))) \\
&= \phi^{-1} (r \times \phi(t_1) + r \times \phi(t_2)) \quad (16) \\
&= \phi^{-1} p (\phi \phi^{-1} m(r, \phi(t_1)), \phi \phi^{-1} m(r, \phi(t_2))) \\
&= \phi^{-1} p (\phi(r \cdot t_1), \phi(r \cdot t_2)) \\
&= \phi^{-1} p \phi^* (r \cdot t_1, r \cdot t_2) \\
&= (r \cdot t_1) \oplus (r \cdot t_2).
\end{aligned}$$

Similarly,

$$\begin{aligned}
(2) \quad (r_1 + r_2) \cdot t &= (r_1 \cdot t) \oplus (r_2 \cdot t), \\
(3) \quad r_1 \cdot (r_2 \cdot t) &= (r_1 r_2) \cdot t, \quad (17) \\
(4) \quad 1 \cdot t &= t
\end{aligned}$$

hold. Thus (T, \oplus, \cdot) is a vector space over R . \square

In particular, we write $r(t_1 \oplus t_2)$ for $r \cdot (t_1 \oplus t_2)$; that is, the operator \cdot is often omitted.

Remark 11. We have the following relations, which are proved from the above facts

$$\begin{aligned}
(1) \quad -(t_1 \oplus t_2) &= -t_1 \oplus (-t_2), \\
(2) \quad -(t_1 \ominus t_2) &= (-t_1 \oplus t_2), \quad (18) \\
(3) \quad t_1 \ominus t_2 &= -t_2 \oplus t_1.
\end{aligned}$$

If we define a function $D : T \times T \rightarrow R^+$ as $D(t_1, t_2) = |\phi(t_1) - \phi(t_2)|$ for each $t_1, t_2 \in T$, then (T, D) is a metric space from the following theorem.

Theorem 12. *(T, D) is a metric space.*

Proof. Let $t_1, t_2, t_3 \in T$. Then

$$\begin{aligned}
(1) \quad D(t_1, t_2) = 0 &\iff \\
|\phi(t_1) - \phi(t_2)| = 0 &\iff \\
\phi(t_1) = \phi(t_2) &\iff \\
t_1 = t_2, & \\
(2) \quad D(t_1, t_2) = |\phi(t_1) - \phi(t_2)| &= |\phi(t_2) - \phi(t_1)| \\
&= D(t_2, t_1),
\end{aligned}$$

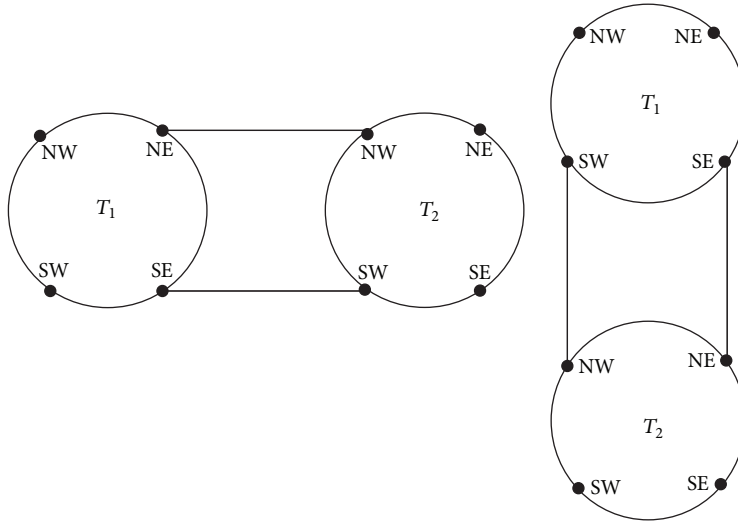

FIGURE 6: Addition and multiplication of tangles.

$$\begin{aligned}
 (3) \quad D(t_1, t_2) &= |\phi(t_1) - \phi(t_2)| \\
 &= |\phi(t_1) - \phi(t_3) + \phi(t_3) - \phi(t_2)| \\
 &\leq |\phi(t_1) - \phi(t_3)| + |\phi(t_3) - \phi(t_2)| \\
 &\leq D(t_1, t_3) + D(t_3, t_2).
 \end{aligned}
 \tag{19}$$

Thus (T, D) is a metric space. \square

Define the norm of t by $\|t\| = D(R(0), t)$. Then we have that $\|t\| = |\phi(t)|$ and $D(t_1, t_2) = |\phi(t_1) - \phi(t_2)| = |\phi(t_1) + \phi(-t_2)| = |\phi(t_1 \oplus (-t_2))| = \|t_1 \oplus (-t_2)\| = \|t_1 \ominus t_2\|$.

Remark 13. We have the following relations:

$$\begin{aligned}
 (1) \quad \|t_1 \otimes t_2\| &= D(R(0), t_1 \otimes t_2) = |0 - \phi(t_1 \otimes t_2)| \\
 &= |\phi(t_1) \times \phi(t_2)| \\
 &= |\phi(t_1)| \times |\phi(t_2)| \\
 &= \|t_1\| \times \|t_2\|, \\
 (2) \quad \|t_1 \oplus t_2\| &= D(R(0), t_1 \oplus t_2) = |0 - \phi(t_1 \oplus t_2)| \\
 &= |\phi(t_1) + \phi(t_2)| \\
 &\leq |\phi(t_1)| + |\phi(t_2)| \\
 &= \|t_1\| + \|t_2\|.
 \end{aligned}
 \tag{20}$$

Define an inequality $<$ (resp. \leq) of t_1, t_2 on T as $t_1 < t_2$ (resp. $t_1 \leq t_2$) $\Leftrightarrow \phi(t_1) < \phi(t_2)$ (resp. $\phi(t_1) \leq \phi(t_2)$).

Remark 14. (1) For each $\epsilon > 0$, $\|t\| < \epsilon$ means that $-t_\epsilon < t < t_\epsilon$ for some $\phi(t_\epsilon) = \epsilon$.

(2) For each $\epsilon > 0$, we have that

$$\begin{aligned}
 \|t_1 \ominus t_2\| < \epsilon &\Leftrightarrow \\
 -t_\epsilon < t_1 \ominus t_2 < t_\epsilon &\Leftrightarrow \\
 -t_\epsilon \oplus t_2 < t_1 < t_\epsilon \oplus t_2 &\Leftrightarrow \\
 t_2 \ominus t_\epsilon < t_1 < t_2 \oplus t_\epsilon,
 \end{aligned}
 \tag{21}$$

for some $\phi(t_\epsilon) = \epsilon$.

In order to determine a group (generally, a vector space) from the set of rational tangles (generally, real tangles), two binary operators \oplus and \otimes are necessary. For other operators, restricted on rational tangles, addition (denote by $\#$) and multiplication (denote by $*$) of horizontal and vertical rational tangles are considered in [1]. In detail, the multiplication of two rational tangles is defined as connecting the top two ends of one tangle to the bottom two endpoints of another, and the addition of two rational tangles is defined as connecting the two leftmost endpoints of one tangle with the two rightmost points of the other as shown in Figure 6.

However the addition of two rational tangles is not necessarily rational, but it can be algebraic tangle [1]. For example, it can be easily seen that the sum of $R(1/2)$ and $R(1/2)$ is not a rational tangle. As the results, in [3], the multiplication (resp., addition) of two rational tangles will be rational tangle if one of two is a vertical (resp., horizontal) tangle. Note that, as a special case of rational tangles, the set of braids is a group under the multiplication. Therefore two operators \oplus and \otimes on rational tangles are a generalization of operators $\#$ and $*$ introduced in [1]. For two operators \oplus and \otimes on real tangles, we do not know yet whether it has a topological or geometrical structure.

In Section 3, we will study some applications for two operators \oplus and \otimes on real tangles. In this paper, the set (T, D) of the real tangles with a metric D is called the tangle space.

3. Some Applications on Tangle Space

3.1. *Tangle Space and Stability.* Let T be the tangle space and $f : T \rightarrow T$ a mapping. Then we prove the generalized Hyers-Ulam stability of the Cauchy additive functional equation as follows.

Theorem 15. *Let $f : T \rightarrow T$ be a mapping such that*

$$\|f(x \oplus y) \ominus (f(x) \oplus f(y))\| < \epsilon \quad (22)$$

for all $x, y \in T$ and for some $\epsilon > 0$. Then there exists a unique additive mapping $Q : T \rightarrow T$ such that $\|f(x) \ominus Q(x)\| < \epsilon$ for all $x \in T$.

Proof. Suppose that $f : T \rightarrow T$ is a mapping such that

$$\|f(x \oplus y) \ominus (f(x) \oplus f(y))\| < \epsilon \quad (23)$$

for all $x, y \in T$ and for some $\epsilon > 0$. Then we have

$$\begin{aligned} \|f(x \oplus y) \ominus (f(x) \oplus f(y))\| < \epsilon \implies \\ f(x) \oplus f(y) \ominus a_\epsilon < f(x \oplus y) < f(x) \oplus f(y) \oplus a_\epsilon, \end{aligned} \quad (I)$$

for some $\phi(a_\epsilon) = \epsilon$.

(1) Putting $x = y$ in (I),

$$2f(x) \ominus a_\epsilon < f(2x) < 2f(x) \oplus a_\epsilon \implies \quad (II)$$

$$f(x) \ominus \frac{a_\epsilon}{2} < \frac{f(2x)}{2} < f(x) \oplus \frac{a_\epsilon}{2} \implies \quad (III)$$

$$\left\| \frac{f(2x)}{2} \ominus f(x) \right\| < \frac{\epsilon}{2}.$$

(2) Putting $x = 2x$ in (II),

$$2f(2x) \ominus a_\epsilon < f(4x) < 2f(2x) \oplus a_\epsilon \implies$$

$$\frac{f(2x)}{2} \ominus \frac{a_\epsilon}{4} < \frac{f(4x)}{4} < \frac{f(2x)}{2} \oplus \frac{a_\epsilon}{4} \implies$$

$$\begin{aligned} f(x) \ominus \frac{a_\epsilon}{2} \ominus \frac{a_\epsilon}{4} < \frac{f(4x)}{4} \\ < f(x) \oplus \frac{a_\epsilon}{2} \oplus \frac{a_\epsilon}{4} \quad (\because \text{by (III)}) \implies \end{aligned} \quad (IV)$$

$$f(x) \ominus \frac{3}{4}a_\epsilon < \frac{f(4x)}{4} < f(x) \oplus \frac{3}{4}a_\epsilon \implies$$

$$\left\| \frac{f(4x)}{4} \ominus f(x) \right\| < \frac{3}{4}\epsilon.$$

(3) Putting $x = 4x$ in (II),

$$2f(4x) \ominus a_\epsilon < f(8x) < 2f(4x) \oplus a_\epsilon \implies$$

$$\frac{f(4x)}{4} \ominus \frac{a_\epsilon}{8} < \frac{f(8x)}{8} < \frac{f(4x)}{4} \oplus \frac{a_\epsilon}{8} \implies$$

$$\begin{aligned} f(x) \ominus \frac{a_\epsilon}{2} \ominus \frac{a_\epsilon}{4} \ominus \frac{a_\epsilon}{8} < \frac{f(8x)}{8} \\ < f(x) \oplus \frac{a_\epsilon}{2} \oplus \frac{a_\epsilon}{4} \end{aligned} \quad (24)$$

$$\oplus \frac{a_\epsilon}{8} \quad (\because \text{by (IV)}) \implies$$

$$f(x) \ominus \frac{7}{8}a_\epsilon < \frac{f(8x)}{8} < f(x) \oplus \frac{7}{8}a_\epsilon \implies$$

$$\left\| \frac{f(8x)}{8} \ominus f(x) \right\| < \frac{7}{8}\epsilon.$$

Putting recursively $x = (2^{n-1})x$ in (II), we have

$$\left\| \frac{f(2^n x)}{2^n} \ominus f(x) \right\| < \frac{2^n - 1}{2^n} \epsilon < \epsilon, \quad (V)$$

where $n \geq 1$.

Define $Q : T \rightarrow T$ by

$$Q(x) = \lim_{n \rightarrow \infty} \frac{f(2^n x)}{2^n} \quad (25)$$

for all $x \in T$; that is, $\lim_{n \rightarrow \infty} \|f(2^n x)/2^n \ominus Q(x)\| = 0$.

Now putting $x = 2^n x$ and $y = 2^n y$ in $\|f(x \oplus y) \ominus f(x) \ominus f(y)\| < \epsilon$, we have

$$\|f(2^n x \oplus 2^n y) \ominus f(2^n x) \ominus f(2^n y)\| < \epsilon \implies$$

$$\left\| \frac{f(2^n(x \oplus y))}{2^n} \ominus \frac{f(2^n x)}{2^n} \ominus \frac{f(2^n y)}{2^n} \right\| < \frac{\epsilon}{2^n} \implies$$

$$\left\| \lim_{n \rightarrow \infty} \frac{f(2^n(x \oplus y))}{2^n} \ominus \lim_{n \rightarrow \infty} \frac{f(2^n x)}{2^n} \ominus \lim_{n \rightarrow \infty} \frac{f(2^n y)}{2^n} \right\| \quad (26)$$

$$< \lim_{n \rightarrow \infty} \frac{\epsilon}{2^n} = 0.$$

Thus $\|Q(x \oplus y) \ominus Q(x) \ominus Q(y)\| = 0$; that is, $Q(x \oplus y) = Q(x) \oplus Q(y)$. Moreover, from (V),

$$\left\| \lim_{n \rightarrow \infty} \frac{f(2^n x)}{2^n} \ominus \lim_{n \rightarrow \infty} f(x) \right\| < \lim_{n \rightarrow \infty} \left(\frac{2^n - 1}{2^n} \right) \epsilon = \epsilon. \quad (27)$$

Thus we have $\|Q(x) \ominus f(x)\| < \epsilon$. Therefore this means that Q is an additive mapping such that $\|Q(x) \ominus f(x)\| < \epsilon$.

To prove the uniqueness of the additive mapping Q , assume that there is another additive mapping $Q' : T \rightarrow T$ such that

$$Q'(x \oplus y) = Q'(x) \oplus Q'(y),$$

$$\|f(x) \ominus Q'(x)\| < \epsilon. \quad (28)$$

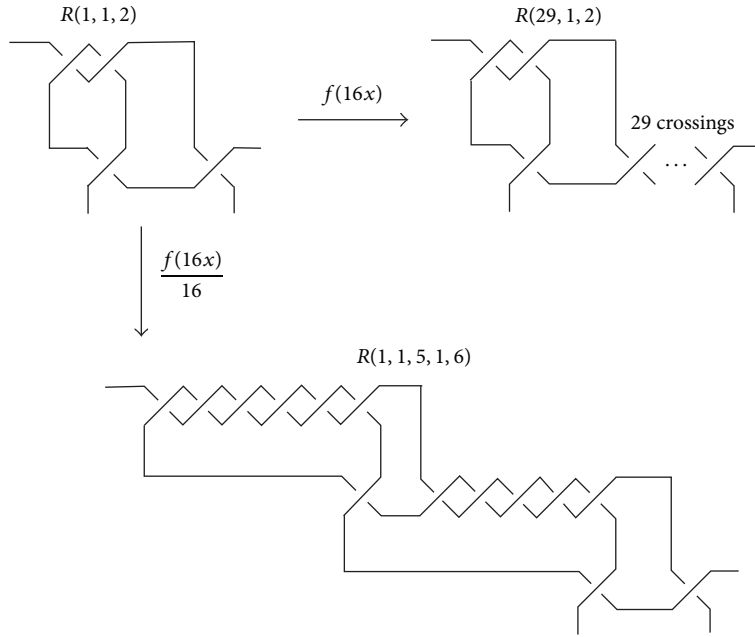

FIGURE 7

From the fact $Q'(2^n x) = 2^n Q'(x)$, we have $Q'(x) = Q'(2^n x)/2^n$. Since $\|f(x) \ominus Q'(x)\| < \epsilon$, we have that

$$\begin{aligned}
 Q'(x) \ominus a_\epsilon &< f(x) < Q'(x) \oplus a_\epsilon \implies \\
 Q'(2^n x) \ominus a_\epsilon &< f(2^n x) < Q'(2^n x) \oplus a_\epsilon \implies \\
 \frac{Q'(2^n x)}{2^n} \ominus \frac{a_\epsilon}{2^n} &< \frac{f(2^n x)}{2^n} < \frac{Q'(2^n x)}{2^n} \oplus \frac{a_\epsilon}{2^n} \implies \\
 Q'(x) \ominus \frac{a_\epsilon}{2^n} &< \frac{f(2^n x)}{2^n} < Q'(x) \oplus \frac{a_\epsilon}{2^n} \implies \\
 \left\| \frac{f(2^n x)}{2^n} \ominus Q'(x) \right\| &< \frac{\epsilon}{2^n} \implies \\
 \left\| \lim_{n \rightarrow \infty} \frac{f(2^n x)}{2^n} \ominus \lim_{n \rightarrow \infty} Q'(x) \right\| &< \lim_{n \rightarrow \infty} \frac{\epsilon}{2^n} = 0,
 \end{aligned} \tag{29}$$

where $\epsilon > 0$ and $\phi(a_\epsilon) = \epsilon$. Thus we have $\|Q(x) \ominus Q'(x)\| = 0$; that is, $Q(x) = Q'(x)$. This completes the proof. \square

For example, let $f : T \rightarrow T$ be a mapping defined by $f(x) = r_1 \cdot x \oplus r_2$, where $r_1, r_2 \in R$, $x \in T$. In fact, r_2 means $r_2 \cdot R(1)$. Then f is not additive mapping. However a mapping $f : T \rightarrow T$ defined by $f(x) = r \cdot x$, $r \in R$ and $x \in T$ is additive. In tangle space T , let $x = R(1, 1, 2)$, $f(x) = x \oplus 3$, and $n = 4$; then $f(16x) = R(29, 1, 2)$ and $f(16x)/16 = R(1, 1, 5, 1, 6)$, where $16x = R(26, 1, 2)$. See Figure 7.

Generally, for each n , the real tangles are as the following:

$$\frac{f(2^n x)}{2^n} = R\left(\frac{14 + \sum_{k=1}^n 52^{k-1}}{2^{n3}}\right) \tag{30}$$

and so the additive mapping $Q(x)$ is real tangle as the following:

$$Q(x) = \lim_{n \rightarrow \infty} R\left(\frac{14 + \sum_{k=1}^n 52^{k-1}}{2^{n3}}\right). \tag{31}$$

3.2. Tangle Space and Rational Knot or Link. Suppose that $T' \subset T$ is the set of rational tangles. Given $t \in T'$, the numerator closure $N(t)$ is formed by connecting the NW and NE endpoints and the SW and SE endpoints, and the denominator closure $D(t)$ is formed by connecting the NW and SW endpoints and connecting the NE and SE endpoints. We note that two operations $N(t)$ and $D(t)$ by connecting the endpoints of t produce knots or 2-component links, called rational knot or link if t is a rational tangle, and that every 2-bridge knot is a rational knot because it can be obtained as the numerator or denominator closure of a rational tangle. See Figure 8.

Let $T' \subset T$ be the set of rational tangles and K the set of rational knots or links. Then for given $t \in T'$, it allows defining a function $N : T' \rightarrow K$ in order that $N(t)$ is the numerator closure. The following theorem discusses equivalence of rational knots or links obtained by taking the numerator closure of rational tangles. We call this theorem the tangle classification theorem

Theorem 16 (see [16]). *Let $R(p/q)$ and $R(p'/q')$ be the rational tangles with reduced fractions p/q and p'/q' , respectively. Then $N(R(p/q))$ and $N(R(p'/q'))$ are topologically equivalent if and only if $p = p'$ and $q^\pm \equiv q' \pmod p$.*

For example, $N(R(0, 3, 2)) = N(R(2/7)) = N(R(2/1)) = N(R(2))$ because $7 \equiv 1 \pmod 2$.

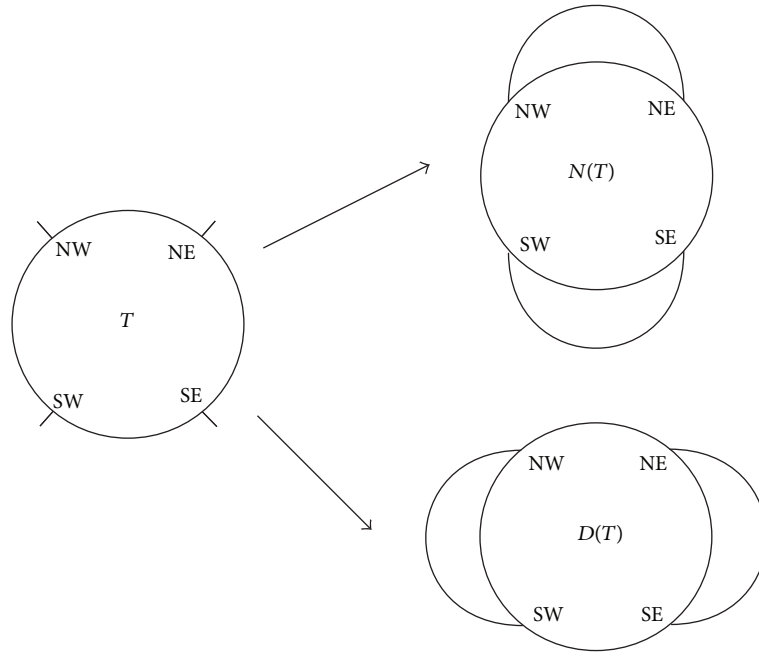

FIGURE 8: The numerator closure and denominator closure of tangle.

Corollary 17. *If two rational tangles are isotopic, then their each numerator's closures are topological equivalent.*

Proof. Let $R(p/q)$ and $R(p'/q')$ be the rational tangles with reduced fractions p/q and p'/q' , respectively. Then $p = p'$ and $q = q'$ because $R(p/q)$ and $R(p'/q')$ are isotopic.

Thus, by Theorem 16, $N(R(p/q))$ and $N(R(p'/q'))$ are topological equivalent. \square

However there is a counterexample for the converse of Corollary 17 as follows.

Example 18. Let $R(1, 2, 2)$ and $R(2, 3)$ be two rational tangles with fractions $7/5$ and $7/3$, respectively. By Theorem 16, $N(R(7/5))$ and $N(R(7/3))$ are topological equivalent, but two tangles $R(7/5)$ and $R(7/3)$ are not isotopic.

Define the numerator closure of the sum of two rational tangles as the following:

$$N\left(R\left(\frac{y_1}{x_1}\right) \oplus R\left(\frac{y_2}{x_2}\right)\right) = N\left(R\left(\frac{x_2 y_1 + x_1 y_2}{x_1 x_2}\right)\right), \quad (32)$$

where $\gcd(x_1, y_1) = \gcd(x_2, y_2) = 1$. Note that the rational knot or link

$$N\left(R\left(\frac{x_2 y_1 + x_1 y_2}{x_1 x_2}\right)\right) \quad (33)$$

is denoted by $b(x_2 y_1 + x_1 y_2, x_1 x_2)$, called the 2-bridge knot or link, and that $b(x_2 y_1 + x_1 y_2, x_1 x_2)$ is to be the 2-bridge knot if $x_2 y_1 + x_1 y_2$ is odd number and the 2-bridge link if not.

A tangle equation is an equation of the form $N(A \oplus B) = K$, where $A, B \in T'$ and $K \in K$. Solving equations of this type will be useful in the tangle model and gaining a better understanding of certain enzyme mechanisms [15].

Example 19. Considering rational tangles $R(2)$ and $R(23/17)$, then $R(2) \oplus R(23/17)$ is the rational tangle $R(3, 2, 1, 5)$ because of $R(23/17) = R(1, 2, 1, 5)$. Thus a tangle equation $N(R(2) \oplus R(23/17)) = N(R(3, 2, 1, 5))$ is representing the 2-bridge knot $b(57, 17)$ from the computation of the numerator closure above.

If one of the tangles in the equation is unknown and the other tangle and the knot K are known, then there is one tangle as the solution of equation, but it is not unique. In fact, let A be known rational tangle and K rational knot or link. Then there are two different rational tangles as the solution of the equation $N(X \oplus A) = K$ which is the topological equivalent under numerator operation in Theorem 16.

Example 20. Let $A = R(1/3)$, 2-bridge knot $K = b(5, 2)$ known, and $X = R(x)$ unknown. Then $X = R(13/6)$ is a solution of the equation $N(X \oplus A) = K$. However $b(5, 2)$ and $b(5, 3)$ are topological equivalent from Theorem 16. Thus $X = R(4/3)$ is the other solution of the equation $N(X \oplus A) = K$ if $K = b(5, 3)$.

From Theorem 16 and Corollary 17, we obtain the following corollary by the method as in Example 20.

Corollary 21. *Let A and K be known rational tangle in T' and rational knot or link in K , respectively. Then there exist two solutions $X \in T'$ of the equation $N(X \oplus A) = K$.*

3.3. Tangle Space and DNA. Suppose that tangles S , T , and R below are rational. As discussed in the introduction of Section 1, DNA must be topologically manipulated by enzymes in order for vital life processes to occur. The actions of some enzymes can be described as site-specific

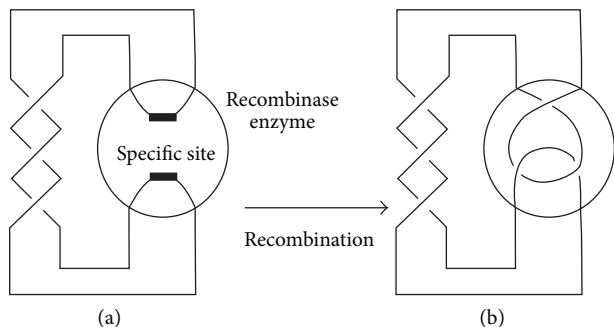

FIGURE 9: Example of a site-specific recombination.

recombination. Site-specific recombination is a process by which a piece of DNA is moved to another position on the molecule or to import a foreign piece of a DNA molecule into it. Recombination is used for gene rearrangement, gene regulation, copy number control, and gene therapy. This process is mediated by an enzyme called a recombinase. A small segment of the genetic sequence of the DNA that is recognized by the recombinase is called a recombination site or a specific site. See Figure 9. Note that the tangle in Figure 9 is where the enzyme acts.

The DNA molecule and the enzyme itself are called the synaptic complexes. Before recombination the DNA molecule is called the substrate, that is, it is unchanged by the enzyme. After recombination the DNA molecule is called the product. In Figure 9, (a) is the substrate and (b) is the product. This is the result which replaces a tangle (or enzyme) with a new tangle, called the recombination tangle. Thus the following tangle equations hold:

$$\begin{aligned} N(S \oplus T) &= \text{the substrate,} \\ N(S \oplus R) &= \text{the product,} \end{aligned} \tag{34}$$

where the product is a result that the enzyme replaces a tangle T with a tangle R . Generally it will repeat the tangle replacement a number of times. If it is possible to observe the substrate and the product; then the ideal situation would be to determinate tangles S , T , and R from the tangle equations. However it is a hard question in general to solve the tangle equations because there are only two equations but three unknowns. As above, the tangle model has been used to mathematically show the enzyme mechanism of recombination. See [17] for similar examples.

Example 22. Let the knot types of the substrate and the product yielding equations in the recombination variables S , T , and R be as follows:

$$\begin{aligned} N(S \oplus T) &= \text{the unknot } b(1, 1), \\ N(S \oplus R) &= \text{the trefoil knot } b(3, 1). \end{aligned} \tag{35}$$

Then solutions of the equations are either $(S, T, R) = (R(-1/2), R(0), R(2))$ or $(S, T, R) = (R(1/2), R(0), R(-2))$.

In our study of tangle space with operator \oplus , it is still unknown how to construct a link or knot associated with a given real tangle and analyze DNA molecules by real tangles.

Competing Interests

The author declares that there is no conflict of interests regarding the publication of this paper.

References

- [1] J. H. Conway, “An enumeration of knots and links and some of their algebraic properties,” in *Proceedings of the Conference on Computational Problems in Abstract Algebra*, J. Leech, Ed., pp. 329–358, Pergamon Press, Oxford, UK, 1970.
- [2] A. Ya. Khinchin, *Continued Fractions*, Dover, 1997, (republication of the 1964 edition of Chicago Univ. Press).
- [3] L. H. Kauffman and S. Lambropoulou, “On the classification of rational tangles,” *Advances in Applied Mathematics*, vol. 33, no. 2, pp. 199–237, 2004.
- [4] S. M. Ulam, *Problems in Modern Mathematics*, Wiley, New York, NY, USA, 1960.
- [5] D. H. Hyers, “On the stability of the linear functional equation,” *Proceedings of the National Academy of Sciences of the United States of America*, vol. 27, pp. 222–224, 1941.
- [6] T. Aoki, “On the stability of the linear transformation in Banach spaces,” *Journal of the Mathematical Society of Japan*, vol. 2, pp. 64–66, 1950.
- [7] T. M. Rassias, “On the stability of the linear mapping in Banach spaces,” *Proceedings of the American Mathematical Society*, vol. 72, no. 2, pp. 297–300, 1978.
- [8] P. Găvruta, “A generalization of the Hyers-Ulam-Rassias stability of approximately additive mappings,” *Journal of Mathematical Analysis and Applications*, vol. 184, no. 3, pp. 431–436, 1994.
- [9] J. Aczel and J. Dhombres, *Functional Equations in Several Variables*, Cambridge University Press, Cambridge, UK, 1950.
- [10] J. Brzdęk, W. Fechner, M. S. Moslehian, and J. Sikorska, “Recent developments of the conditional stability of the homomorphism equation,” *Banach Journal of Mathematical Analysis*, vol. 9, no. 3, pp. 278–326, 2015.
- [11] K. Ciepliński, “Applications of fixed point theorems to the Hyers-Ulam stability of functional equations—a survey,” *Annals of Functional Analysis*, vol. 3, no. 1, pp. 151–164, 2012.
- [12] S. Czerwik, *Functional Equations and Inequalities in Several Variables*, World Scientific Publishing, River Edge, NJ, USA, 2002.
- [13] S.-M. Jung, *Hyers-Ulam-Rassias Stability of Functional Equations in Nonlinear Analysis*, vol. 48 of *Springer Optimization and Its Applications*, Springer, New York, NY, USA, 2011.
- [14] T. M. Rassias, “On the stability of functional equations in Banach spaces,” *Journal of Mathematical Analysis and Applications*, vol. 251, no. 1, pp. 264–284, 2000.
- [15] D. W. Sumners, “Untangling DNA,” *The Mathematical Intelligencer*, vol. 12, no. 3, pp. 71–80, 1990.
- [16] L. H. Kauffman and S. Lambropoulou, “From tangle fractions to DNA,” in *Topology in Molecular Biology*, Biological and Medical Physics, Biomedical Engineering, pp. 69–110, Springer Berlin Heidelberg, Berlin, Germany, 2007.
- [17] M. Vazquez and D. W. Sumners, “Tangle analysis of Gin site-specific recombination,” *Mathematical Proceedings of the Cambridge Philosophical Society*, vol. 136, no. 3, pp. 565–582, 2004.



Hindawi

Submit your manuscripts at
<http://www.hindawi.com>

