

Dissemination of a Single Clone of Methicillin-Resistant *Staphylococcus aureus* among Turkish Hospitals

ALEX VAN BELKUM,^{1*} WILLEM VAN LEEUWEN,¹ ROEL VERKOOYEN,¹ SEFA CAN SAÇILIK,² CUMHUR COKMUS² AND HENRI VERBRUGH¹

Department of Medical Microbiology & Infectious Diseases, University Hospital Rotterdam, 3015 GD Rotterdam, The Netherlands,¹ and Department of Biology, Faculty of Sciences, Ankara University, 06100 Tandoğan, Ankara, Turkey²

Received 7 October 1996/Returned for modification 19 December 1996/Accepted 6 January 1997

A collection of 39 methicillin-resistant *Staphylococcus aureus* (MRSA) strains derived from six different hospitals in Ankara and one hospital in Bursa, Turkey, were analyzed by multiple genotyping. In agreement with the other genotyping assays, pulsed-field gel electrophoresis of DNA macrorestriction fragments identified genetic homogeneity among all MRSA isolates studied. It is concluded that a major clone of MRSA has spread through a large part of Turkey, causing longitudinally persistent colonization in all of the institutions surveyed.

Staphylococcus aureus has remained a major cause of nosocomial morbidity and mortality, and as an additional clinical problem, methicillin-resistant *S. aureus* (MRSA) emerged at an alarming rate in the 1980s (8, 9). Consequently, analysis of the dissemination of MRSA isolates has been a research focus for the past decade. Resistance to methicillin, which is often accompanied by other forms of antimicrobial resistance, is usually a direct consequence of the acquisition of another penicillin-binding protein (PBP 2a) gene, called *mecA* (7). In addition to *mecA* regulatory genes like *mecI* and *mecR*, numerous auxiliary genes contributing to the overall level of methicillin resistance of a strain have been identified (5). Apparently, the genetic background in which the *mecA* gene is embedded is of immediate importance to the clinical threat that a given strain poses. Analysis of the genetic background by molecular typing techniques is important in the sense that specific DNA characteristics may be correlated with important phenomena such as strain epidemicity and virulence. International epidemiologic surveillance requires reliable techniques capable of differentiating independent strains from clonally related strains, and molecular pheno- and genotyping techniques have been optimized for the purpose of studying the spread of MRSA. All procedures applied thus far have specific experimental drawbacks (17). Pulsed-field gel electrophoresis (PFGE) has proven to be highly discriminatory for MRSA isolates, and it has been suggested that it is superior to other genotyping techniques. However, this method is fairly laborious, and the DNA restriction patterns may be difficult to interpret (18). Moreover, interlaboratory standardization of PFGE is still problematic (2). Randomly amplified polymorphic DNA analysis has proven to be a rapid technique that yields epidemiologically valid results. Again, however, its interlaboratory reproducibility needs improvement (20). Thus, the continued need for accurate genotyping systems that can be applied in clinical laboratories is evident. It has been suggested that only the combined application of various typing schemes allows for an accurate analysis of clonal relatedness among MRSA isolates (12).

In the present study a collection of MRSA strains from six different hospitals in the Ankara region and a single hospital in

the city of Bursa, 380 km apart in Turkey, were analyzed by multiple genotyping procedures. The use of ribotyping, random amplification of polymorphic DNA, isolate-specific DNA probes, and PFGE enables assessment of the putative clonal spread of MRSA in that part of the world.

Bacterial strains, cultivation, and antibiotic susceptibility testing. A collection of 39 MRSA strains was obtained from seven different hospitals, of which six are located in Ankara (hospital A, Department of Infectious Diseases and Clinical Microbiology, Medical School, Uledag University, Bursa; hospital B, Department of Bacteriology, Medical School, Ankara University, Ankara; hospital C, Department of Bacteriology, Medical School, Ankara; Hacitpe hospital D, Department of Bacteriology, Medical School, Gazi University, Ankara; E, Yuksek Intisas Hospital, Turkish Ministry of Health, Ankara; hospital F, Department of Infectious Diseases and Clinical Microbiology, Gulhane Military Medical Academy, Ankara; and hospital G, Medical School, Cebeci Hospital, Ankara University, Ankara). Colonies were selected on the basis of morphological characteristics, checked by Gram staining, and tested for catalase and coagulase production. Coagulase production was assayed by the citrate-plasma tube technique (11). Swabs were inoculated directly onto 5% blood agar, mannitol salt agar, and DNase test medium. Subsequently, the swabs were incubated in broth enrichment medium with 6.5% NaCl (37°C for 18 h) or Stuart's transport medium (7 days at 4°C) (11). All solid media were incubated at 37°C for 16 h, after which the plates were placed at room temperature. Semiquantitative detection of susceptibility toward antibiotics, specifically, oxacillin and methicillin, was performed by well-established disc diffusion procedures (10). All antibiotics except cefoperazone-sulbactam were purchased from Oxoid (Unipath, Haarlem, The Netherlands); cefoperazone-sulbactam was purchased from BBL (Becton Dickinson, Etten-Leur, The Netherlands).

DNA isolation. For DNA isolation, bacteria were grown in suspension in brain heart infusion broth for 18 h at 37°C. Spheroplasts were produced by incubation with lysostaphin and were lysed by the addition of 1 ml of 4 M guanidinium isothiocyanate–50 mM Tris · HCl (pH 6.4)–3 mM EDTA–1% (wt/wt) Triton X-100. DNA was purified by Celite affinity chromatography (1a). Stock solutions of bacterial DNA were adjusted to a concentration of 5 ng per 10 µl and were stored at –20°C.

* Corresponding author. Mailing address: University Hospital Rotterdam, Department of Medical Microbiology and Infectious Diseases, Dr. Molewaterplein 40, 3015 GD Rotterdam, The Netherlands. Phone: 31-10-4635813. Fax: 31-10-4633875. E-mail: vanbelkum@bacl.azr.nl.

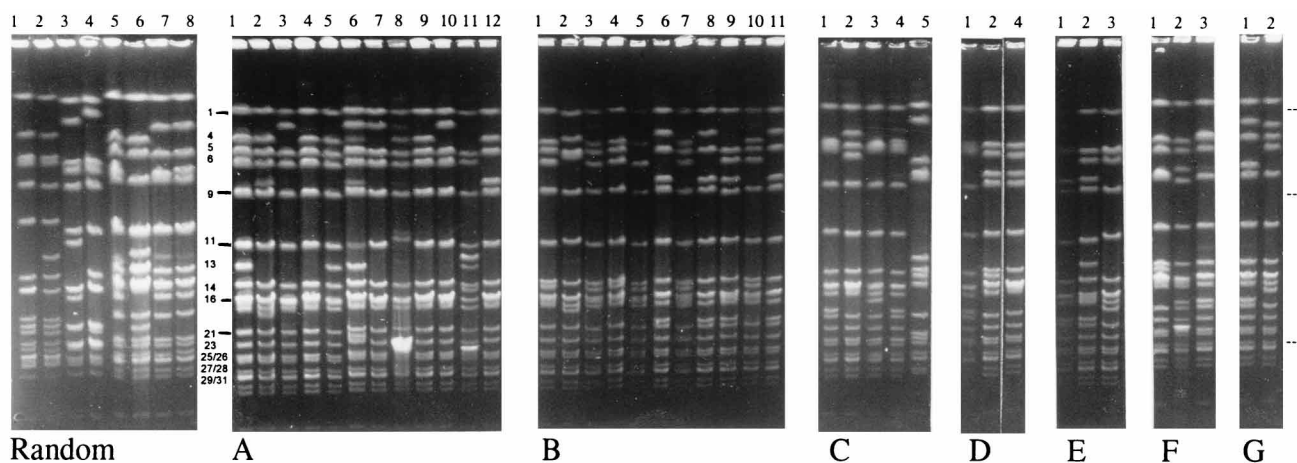

FIG. 1. PFGE of *Sma*I macrorestriction fragments of MRSA isolates from the Ankara region and Bursa. The numbering above the lanes and the letters beneath the panels identify the strains. The numbers between the panel labeled Random and panel A indicate the DNA fragment numbering used for position scoring. (Random) Analysis of some reference strains: lanes 1 and 2, isolates from the Iberian clone (14); lanes 3 and 4, isolates of the major Polish clone AA; lanes 5 to 8, isolates of the major Polish clone BB (19). Note that some banding features of the Polish BB type are shared with the Turkish strains; identity is not obvious, however. On the right three molecular length markers are given (10, 5, and 1 Mb, from top to bottom, respectively).

Ribotyping. Conventional ribotyping with *Eco*RI was performed by methods described previously (6). Restriction fragments were Southern blotted onto Hybond N⁺ membranes (Amersham, Buckinghamshire, United Kingdom) (13), and the *Escherichia coli* 16S rRNA gene, amplified by PCR, was used as a probe. Hybridization was detected by using the enhanced chemiluminescent Amersham ECL kit (Amersham).

Arbitrarily primed PCR. PCR was performed essentially as described before (20). Cycling was performed in Biomed PCR machines (model 60) and consisted of the following steps: predenaturation at 94°C for 4 min and 35 cycles of 1 min at 94°C, 1 min at 25°C, and 2 min at 74°C. The primer used to discriminate *S. aureus* strains was ERIC2 (5'-AAGTAAGTGACTGGGGTGAGCG-3'), which was previously shown to effectively discriminate among both methicillin-susceptible *S. aureus* and MRSA strains (23). Amplification products were separated by electrophoresis in 1% agarose gels (Hispanagar; Sphaero Q, Leiden, The Netherlands). Gels were photographed with a Polaroid MP4 Landcamera and Polaroid 57 High-Speed films. The banding patterns visualized in this manner were indexed with capital letters. Even single band differences led to the definition of a novel type.

PFGE. PFGE was performed with a CHEF Mapper (Bio-Rad, Veenendaal, The Netherlands) in the autoalgorithm mode (2). DNA was digested with the restriction enzyme *Sma*I (New England Biolabs, Hitchin, United Kingdom). Several strains from geographically diverse regions were included as control strains for the determination of resemblance to the Turkish strains. Interpretation was done by using previously determined standards (18). All bands were scored manually for their presence or absence in a given PFGE fingerprint. Banding patterns were translated into a binary code, and phylogenetic trees were constructed with the help of computer programs accessible through the Internet (PHYLIP, version 3.5c; Phylogeny Interference Package, University of Seattle, Seattle, Wash.). The maximum likelihood method was used to estimate phylogenetic distances between strains.

Hybridization studies with isolate-specific DNA probes. Differentiation of staphylococcal strains can be based upon their reactivities toward isolate-specific DNA probes (21). Southern blots of purified staphylococcal DNA were prepared as de-

scribed above (see ribotyping section). Probe labelling, hybridization, and detection were performed with the ECL direct labelling and detection systems (Amersham). Six different DNA probes were applied, and hybridization was scored as plus or minus according to the presence or absence of hybridization signal, respectively.

Results of the typing studies. Upon antibiotic susceptibility testing it became apparent that all strains except strain C4 produced β -lactamase and were uniformly resistant to oxacillin, methicillin, tobramycin, penicillin, cefuroxime, cefataxim, ceftazidime, piperacillin, flucloxacillin, cefipime, metronidazole, aztreonam, and cefaperazone-sulbactam. Toward the other antibiotics tested (ciprofloxacin, ofloxacin, netilmicin, erythromycin, tetracycline, imipenem, chloramphenicol, and co-trimoxazole), differential susceptibility was found, although toward erythromycin and tetracycline only resistant and intermediately resistant phenotypes were found. There appeared to be no close relationship between the antibiogram and the originating hospital.

Only two different but closely related ribotypes could be detected. Either five (type A) or six (type B) DNA fragments hybridized to the rRNA gene probe. The B type was documented in 8 of 39 strains (prevalence, 21%) and occurred in five of seven institutions. In hospital C the incidence of type B was 60%, possibly indicating spread among the patients nursed there and that the type is endemic. In hospitals G and D the B type was not encountered. Arbitrarily primed PCR with primer ERIC2 revealed three different patterns only. The two most frequently observed types (types A and B) differed by a single band, whereas the most aberrant type (type C) occurred only once (strain C5, hospital C). Although there appeared to be no 100% overlap, the arbitrarily primed PCR B type seemed to be linked to a B ribotype. Probing of genomic DNA with DNA probes capable of differentiating among the MRSA strains (21) fully corroborated the arbitrarily primed PCR and ribotyping data.

PFGE was carried out to obtain definite proof of the observed homogeneity of this cluster of MRSA isolates. The gels are shown in Fig. 1. Overall, 31 different, position-based bands could be observed, and the pattern obtained for each strain was scored for the absence or presence of each band. On the basis

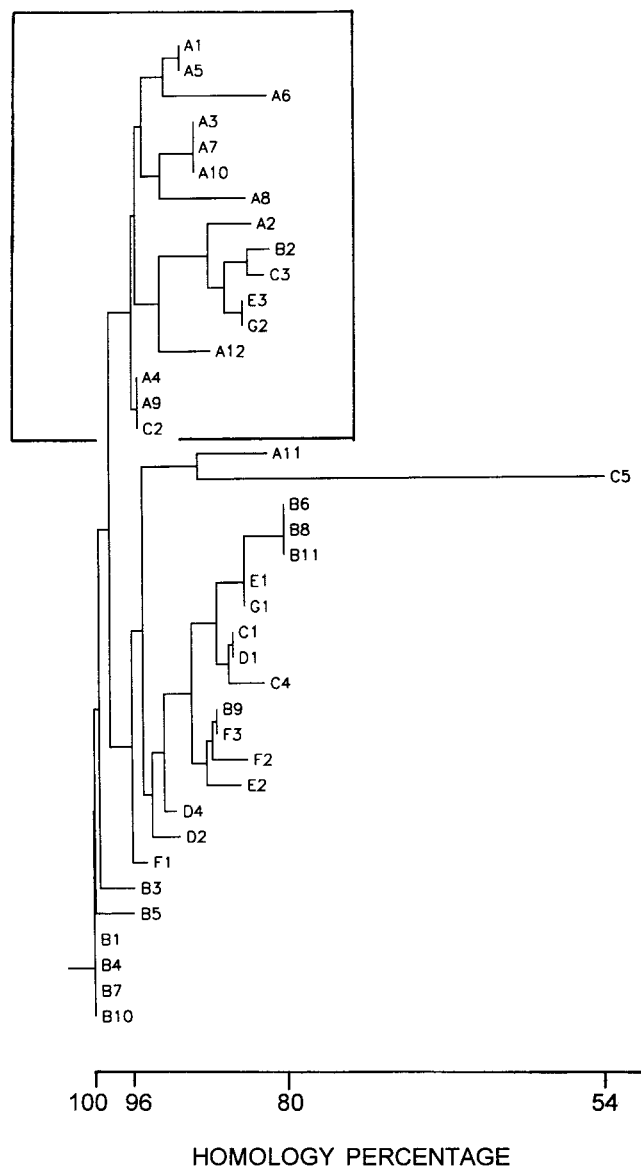

FIG. 2. Phylogenetic tree displaying the grouping of the MRSA strains from the Ankara region and Bursa on the basis of the banding pattern score after PFGE analysis. Note that strains from hospital I (A1 through A12) group on top of the figure (boxed region).

of this band presence score a phylogenetic tree could be constructed (Fig. 2). Except for strain C5, all of the MRSA isolates fell within a 10% difference margin compared to the average homology value of 90%, indicating that a three-band difference was the maximal divergence (3 of 31 bands equals approximately 10%). All of the strains from the hospital in Bursa cluster at the top of Fig. 2 (see boxed region). This indicates that resident strains established in a given hospital evolve, albeit slowly, and may in the end present as a separate, novel genetic entity. All of the control strains included in the present study were representatives of some of the major European MRSA clones and were clearly more distant from the study strains at the PFGE type level. Additional studies into the precise nature of the *mec* region may shed light on the archetype from which the present Turkish MRSA isolates descended (7).

Consequently, it can be concluded that 38 of 39 of the MRSA isolates belong to a single, genetically homogeneous cluster of strains. Only strain C5 had aberrant results; this isolate was possibly imported and was not a local nosocomially acquired resident strain. Strains from the single hospital that was remote from the others tended to cluster separately, but the genetic distance to the Ankara strains was still limited.

Spread of MRSA isolates. A primarily clonal spread of MRSA has been suggested (8), whereas other reports suggest that multiple episodes of horizontal gene transfer among staphylococci have occurred and that multiple major MRSA clones exist (9). Examples of the latter phenomenon in which major MRSA clones successfully spread over large geographic areas have recently been documented. Nationwide dispersal of a given MRSA genotype has been demonstrated for several West European countries such as Belgium (15), Poland (19), and Germany (25). In Portugal and Spain a major MRSA type crossed borders and became highly prevalent in both countries (14). The United Kingdom also has a history of major episodes of colonization and infection caused by epidemic MRSA strains (4). Outside of Europe, other epidemic MRSA isolates have also been described (16). On the contrary, several institutions have described an increase in the number of different MRSA genotypes encountered among their patients (3). This may be explained by an increase in the number of people in the general population colonized with MRSA. This conclusion was underscored by a recent pan-European surveillance of the prevalence of MRSA in which it was emphasized that both epidemic and non-epidemic MRSA isolates exist and that these types may coexist in the same environment (24). The factors that determine whether a strain becomes responsible for an epidemic are largely unknown (22), but it is obvious that large differences in the behaviors of MRSA isolates from different clinical settings can be observed. For that reason it is worthwhile to continue the search for epidemic MRSA strains and, after identification, study those particular strains in more detail with respect to the determinants that cause the spread.

A single clone of MRSA in Turkey. We have shown here that a major MRSA clone circulates in hospitals in the Ankara and Bursa regions of Turkey. With the help of genetic typing procedures, the genetic homogeneity among Turkish MRSA isolates is well established. Apparently, the MRSA strain involved is very well adapted to the clinical setting and is capable of dissemination and local maintenance. It remains to be seen whether the Turkish clone is genetically similar to one of the other major European MRSA types, although preliminary data reveal that no obvious homologies with two Polish and the Iberian clones of MRSA seem to exist at the DNA level. Preliminary data on the genetic resemblance of strains from Istanbul, Turkey, which is 440 km away from Ankara, already indicate that in the Turkish capital strains belonging to the same clonal lineage can also be identified (1). When analyzing the strains from Bursa and comparing them to the ones from Ankara, subtle genetic differences were observed: strains from Bursa tend to cluster separately, but are not distant. Apparently, local adaptation or small-scale evolution occurs once the strains become geographically isolated.

Ismet Berber is acknowledged for excellent technical assistance. We thank Cüneyt Özakin, Yakult Akyön, and Ayten Küçükaraşlan for collecting the samples from the hospitals.

REFERENCES

- Acuner, C., and A. van Belkum. Unpublished data.
- Boom, R., C. J. A. Sol, M. M. M. Salimans, C. L. Jansen, P. M. E. Wertheim-van Dillen, and J. Van der Noordaa. 1990. Rapid and simple method for purification of nucleic acids. *J. Clin. Microbiol.* 28:495-503.

2. Cookson, B. D., P. Aparicio, A. Deplano, M. Struelens, R. Goering, and R. Marples. 1996. Inter-centre comparison of pulsed-field gel electrophoresis for the typing of methicillin resistant *Staphylococcus aureus*. *J. Med. Microbiol.* **44**:179–184.
3. Couto, I., J. Melo-Cristino, M. L. Fernandes, T. Garcia, N. Serrano, M. J. Salgado, A. Torres-Pereira, I. Santos Sanches, and H. de Lencastre. 1995. Unusually large number of methicillin resistant *Staphylococcus aureus* clones in a Portuguese hospital. *J. Clin. Microbiol.* **33**:2032–2035.
4. Cox, R. A., C. Mallaghan, C. Conquest, and J. King. 1995. Epidemic MRSA: controlling the spread outside hospitals. *J. Hosp. Infect.* **29**:107–119.
5. De Lencastre, H., and A. Tomasz. 1994. Reassessment of the number of auxiliary genes essential for high-level methicillin resistance in *Staphylococcus aureus*. *Antimicrob. Agents Chemother.* **38**:2590–2598.
6. Grimont, F., M. Lefevre, E. Ageron, and P. A. D. Grimont. 1989. rRNA gene restriction patterns of *Legionella* species: a molecular identification system. *Res. Microbiol.* **140**:615–626.
7. Hiramatsu, K. 1995. Molecular evolution of MRSA. *Microbiol. Immunol.* **39**:531–543.
8. Kreiswirth, B., J. Kornblum, R. D. Arbeit, W. Eisner, J. N. Maslow, A. McGeer, D. E. Low, and R. P. Novick. 1993. Evidence for a clonal origin of methicillin-resistance in *Staphylococcus aureus*. *Science* **259**:227–230.
9. Musser, J. M., and V. Kapur. 1992. Clonal analysis of methicillin-resistant *Staphylococcus aureus* strains from intercontinental sources: association of the *mec* gene with divergent phylogenetic lineages implies dissemination by horizontal transfer and recombination. *J. Clin. Microbiol.* **30**:2058–2063.
10. National Committee for Clinical Laboratory Standards. 1993. Performance standards for antimicrobial disk susceptibility test. National Committee for Clinical Laboratory Standards, Villanova, Pa.
11. Riewerts Eriksen, N. H., F. Espersen, V. Thandrup Rosdahl, and K. Jensen. 1994. Evaluation of methods for the detection of nasal carriage of *Staphylococcus aureus*. *APMIS* **102**:407–412.
12. Sabria Leal, M., V. H. Morthland, M. L. Pedro Botet, N. Sopena, M. Gimenez Perez, M. L. Branchini, and M. A. Pfaller. 1994. Molecular epidemiology for local outbreaks of methicillin resistant *Staphylococcus aureus*. The need for several methods. *Eur. J. Epidemiol.* **10**:325–330.
13. Sambrook, J., F. Fritsch, and T. Maniatis. 1989. Molecular cloning: a laboratory manual, 2nd ed. Cold Spring Harbor Laboratory Press, Cold Spring Harbor, N.Y.
14. Sanches, I. S., M. Ramirez, H. Troni, M. Abecassis, M. Padua, A. Tomasz, and H. de Lencastre. 1995. Evidence for the geographic spread of a methicillin resistant *Staphylococcus aureus* clone between Portugal and Spain. *J. Clin. Microbiol.* **33**:1243–1246.
15. Struelens, M. J., A. Deplano, C. Godard, N. Maes, and E. Serruys. 1992. Epidemiologic typing and delineation of genetic relatedness of methicillin-resistant *Staphylococcus aureus* by macrorestriction analysis of genomic DNA by using pulsed-field gel electrophoresis. *J. Clin. Microbiol.* **30**:2599–2605.
16. Teixeira, L. A., C. A. Resende, L. R. Ormonde, R. Rosenbaum, A. M. Figueiredo, H. de Lencastre, and A. Tomasz. 1995. Geographic spread of epidemic multiresistant *Staphylococcus aureus* clone in Brazil. *J. Clin. Microbiol.* **33**:2400–2404.
17. Tenover, F. C., R. Arbeit, G. Archer, J. Biddle, S. Byrne, R. Goering, G. Hancock, G. A. Hébert, B. Hill, R. Hollis, W. R. Jarvis, B. Kreiswirth, W. Eisener, J. Maslow, L. K. McDougal, J. M. Miller, M. Mulligan, and M. A. Pfaller. 1994. Comparison of traditional and molecular methods of typing isolates of *Staphylococcus aureus*. *J. Clin. Microbiol.* **32**:407–415.
18. Tenover, F. C., R. D. Arbeit, R. V. Goering, P. A. Mickelsen, B. E. Murray, D. H. Persing, and B. Swaminathan. 1995. Interpreting chromosomal DNA restriction patterns produced by pulsed-field gel electrophoresis: criteria for bacterial strain typing. *J. Clin. Microbiol.* **33**:2233–2239.
19. Trzcinski, K., W. Hryniewicz, H. Claus, and W. Witte. 1994. Characterisation of the different clusters of clonally related methicillin resistant *Staphylococcus aureus* strains by conventional and molecular typing. *J. Hosp. Infect.* **28**:113–126.
20. Van Belkum, A., J. Kluytmans, W. van Leeuwen, R. Bax, W. Quint, E. Peters, A. Fluit, C. Vandembroucke-Grauls, A. van den Brule, H. Koeleman, W. Melchers, J. Meis, A. Elaichouni, M. Vaneechoutte, F. Moonens, N. Maes, M. Struelens, F. Tenover, and H. Verbrugh. 1995. Multicenter evaluation of arbitrarily primed PCR for typing of *Staphylococcus aureus* strains. *J. Clin. Microbiol.* **33**:1537–1547.
21. Van Leeuwen, W., M. Sijmons, J. Sluijs, H. A. Verbrugh, and A. van Belkum. 1996. On the nature and use of randomly amplified DNA from *Staphylococcus aureus*. *J. Clin. Microbiol.* **34**:2770–2777.
22. Van Wamel, W. J. B., A. C. Fluit, T. Wadstrom, H. van Dijk, J. Verhoef, and C. M. J. E. Vandembroucke-Grauls. 1995. Phenotypic characterisation of epidemic versus sporadic strains of methicillin-resistant *Staphylococcus aureus*. *J. Clin. Microbiol.* **33**:1769–1774.
23. Versalovic, J., T. Koeth, and J. R. Lupski. 1991. Distribution of repetitive DNA sequences in eubacteria and application to fingerprinting of bacterial genomes. *Nucleic Acids Res.* **19**:6823–6831.
24. Voss, A., D. Milatovic, C. Wallrauch-Schwarz, V. T. Rosdahl, and I. Braveny. 1994. MRSA in Europe. *Eur. J. Clin. Microbiol. Infect. Dis.* **13**:50–55.
25. Witte, W., C. Cuny, E. Halle, H. Mauch, and J. Wagner. 1994. Methicillin resistance in an epidemic *Staphylococcus aureus* strain with genomic fingerprints corresponding to those of a sensitive strain in the community. *Med. Microbiol. Lett.* **3**:388–395.