

Technical University of Denmark



Scientific Tools for Fuel Characterization for Clean and Efficient Biomass Combustion SciToBiCom, work package 6: Fuel pretreatment

Hansen, Brian Brun; Jensen, Peter Arendt

Publication date:
2013

Document Version
Publisher's PDF, also known as Version of record

[Link back to DTU Orbit](#)

Citation (APA):
Hansen, B. B., & Jensen, P. A. (2013). Scientific Tools for Fuel Characterization for Clean and Efficient Biomass Combustion: SciToBiCom, work package 6: Fuel pretreatment. Technical University of Denmark, Department of Chemical and Biochemical Engineering.

DTU Library Technical Information Center of Denmark

General rights

Copyright and moral rights for the publications made accessible in the public portal are retained by the authors and/or other copyright owners and it is a condition of accessing publications that users recognise and abide by the legal requirements associated with these rights.

- Users may download and print one copy of any publication from the public portal for the purpose of private study or research.
- You may not further distribute the material or use it for any profit-making activity or commercial gain
- You may freely distribute the URL identifying the publication in the public portal

If you believe that this document breaches copyright please contact us providing details, and we will remove access to the work immediately and investigate your claim.

Energinet.dk project no. 10311

Scientific tools for fuel characterization for clean and efficient biomass combustion (SciToBiCom)

Work package 6: Fuel pretreatment

Mass and energy balance of a combined milling and torrifaction process

Brian Brun Hansen and Peter Arendt Jensen

Department of Chemical and Biochemical Engineering

Technical University of Denmark

DK-2800 Kgs Lyngby, Denmark

Process outline

This report describes the design considerations regarding the dimensions of 2 potential setups (illustrated by figure 1) of a combined torrefaction and ball mill plant converting 100 MW biomass into torrefied biomass and gas for a suspension-fired power plant unit. The biomass and a hot recycled gas stream will be introduced to the combined ball mill and torrefaction reactor, where the particles will undergo low temperature pyrolysis, becoming more brittle, and be ground into smaller particles (less than 1 mm) suitable for suspension fired boilers. The fine particles leaving the reactor with the gas stream will be separated and sent to the boiler, while part of the gas stream will be combusted to supply the energy needed for the torrefaction process. The two possible plant designs shown in figure 1 differ with respect to how the gas combustion is integrated with the combined ball mill and torrefaction reactor. In design 1 a part of the gas leaving the torrefaction reactor is purged from the recycle loop and combusted thereby supplying heat (transferred by a heat exchanger) for the oxygen free recycled gas, which is led to the reactor. Design 2 heat exchange the gas leaving the torrefaction reactor with the air for partial combustion and subsequently purge part of the torrefaction gas before performing a partial combustion of the recycled stream (at a sub-stoichiometric air to fuel ratio, to ensure that no oxygen enters the reactor) to supply heat before the gas is led to the reactor. The heat exchange of the torrefaction gas before the fan in design 2 is expected to limit the temperature the fan is exposed to and thereby its durability. The purge before the partial combustion in design 2 will limit the concentration of combustibles in the recycle stream, but the design will be more dependent on the energy content of the gas released by torrefaction, because combustibles will be purged to the boiler (and therefore not used in the torrefaction plant) by the substantial purge flow created by air addition to the recycle stream. The performance and size of the 2 designs will be compared based on mass and energy balances as well as an evaluation of the internal and external heat transfer for different biomass particle sizes.

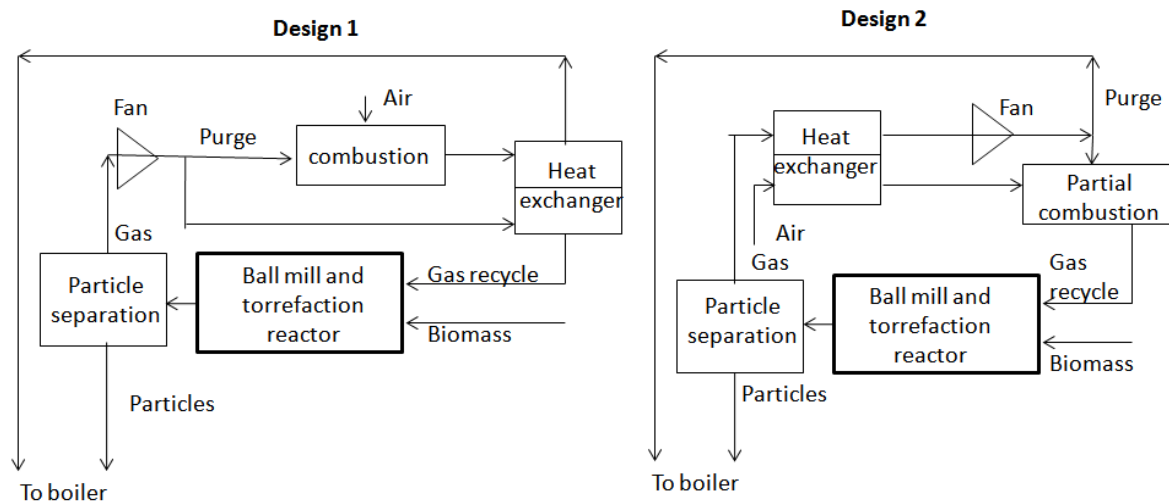

Figure 1: Two potential torrefaction plant outlines

Feed rate & energy input

The amount of straw or woody biomass (with 5 % H₂O) needed to supply a 100 MW_t plant can be calculated by equation 1, assuming that the energy released during processing (heating of materials and release of combustibles) is fully utilised in a connected power plant boiler. The 25 t/h corresponds to approximately 48 big bales of straw or 84 m³ wood chips per hour.

$$m_{5\%H_2O} = \frac{100MWh \cdot 3600MJ / MWh}{15MJ / kg \cdot 0.95} = 25260 \frac{kg}{h} \quad [1]$$

The energy input required to heat the dry biomass to 270 °C is 3.07 MW (see equation 2), assuming no torrefaction mass loss takes place before 270 °C. Some of this energy used for heating will subsequently be released to the gas phase alongside some combustibles during the torrefaction process. The presence of 5 wt % moisture increases the required heat input with 0.91 MW. This means that a total thermal input of 3.98 MW is needed to operate the torrefaction reactor. In addition to these numbers additional energy/electricity inputs, such as for the rotation of the cylinder, may be required.

$$Q_{dry_feed} = m_{wood,dry} \cdot C_{p,wood} \cdot \Delta T + \frac{\% H_2O}{100 - \% H_2O} \cdot m_{wood,dry} \cdot (H_{vap} + C_{p,H_2O} \cdot (T_{boil} - T_{start})) \quad [2]$$

$$\Rightarrow Q_{dry_feed} = 6.7 \frac{kg}{s} \cdot 1.84 \cdot 10^{-3} \frac{MJ}{kg \cdot ^\circ C} \cdot (270 - 20)^\circ C = 3.07 MW$$

$$\Rightarrow Q_{5wt\% H_2O} = 3,07 + \frac{0.05 \cdot m_{wood,dry}}{0.95} \cdot \left(2.257 \frac{MJ}{kg} + 4.18 \cdot 10^{-3} \frac{MJ}{kg \cdot C} \cdot 80^\circ C \right) = 3,98 MW$$

Mass and energy balances

Figure 2, 3 and 4 provides an overview of the mass and energy balances of the 2 proposed designs using torrefaction temperatures of 270 °C and 300 °C (only design 2) - shown for a input biomass moisture content of 5 wt. %.

The energy streams consist of three components: the enthalpy that can be released by combustion (H_c, obtained from heating value data), the thermal energy/heat (H_t) and the latent heat of evaporation contained by the water vapour (H_e). The inlet temperature (20 °C) is used as the reference temperature with respect to the thermal energy. The following assumptions and approaches are used in the calculations:

- Initial biomass heating value = 15 MJ/kg
- Biomass moisture content = 5 wt. %
- Torrefaction at 270 °C yields a 10 % mass loss and a 5 % loss of initial heating value to the gas phase [Saleh et al., 2013].

- Torrefaction at 300 °C yields a 16 % mass loss and a 8 % loss of initial heating value to the gas phase [Saleh et al., 2013].
- Heat capacity of the solid = 1.84 kJ/kg/C [Babu & Chaurasia, 2004]
- Heat capacity of the recycled gas = 1.2 kJ/kg/C [Babu & Chaurasia, 2004]
- The exothermic hemicellulose decomposition and subsequent decomposition of lignocellulosic compounds is assumed negligible compared to the drying and solid heating
 - Exothermic hemicellulose decomposition = 40-280 kJ/kg_{biomass} [Bates & Ghoniem, 2013.]
 - Decomposition of lignocellulosic compounds (can both be endothermic and exothermic)
 - Drying (120 kJ/kg at 5 wt % H₂O)
 - Solid heating (445 kJ/kg_{biomass} for heating to 270 °C)
- Biomass heating value after torrefaction at 270 °C = 0.95*15/0,9 = 15.8 MJ/kg
Biomass heating value after torrefaction at 300 °C = 0.92*15/0,84 = 16.4 MJ/kg
- Heating value of the released torrefaction gas at 270 °C = 15*0.05/0.1 = 7.5 MJ/kg
Heating value of the released torrefaction gas at 300 °C = 15*0.08/0.16 = 7.5 MJ/kg
- Heat exchangers are running counter-currently and need a minimum driving force of 30 °C
- The combustion take place as methane combustion ($\text{CH}_4 + 2\text{O}_2 \rightarrow 2\text{H}_2\text{O} + \text{CO}_2$) – i.e. no change in the molar concentration of the system.
- Combustion of the gas stream will take place at an air to fuel ration of 1.2 for design 1 and an air to fuel ration of 1.0 for design 2.

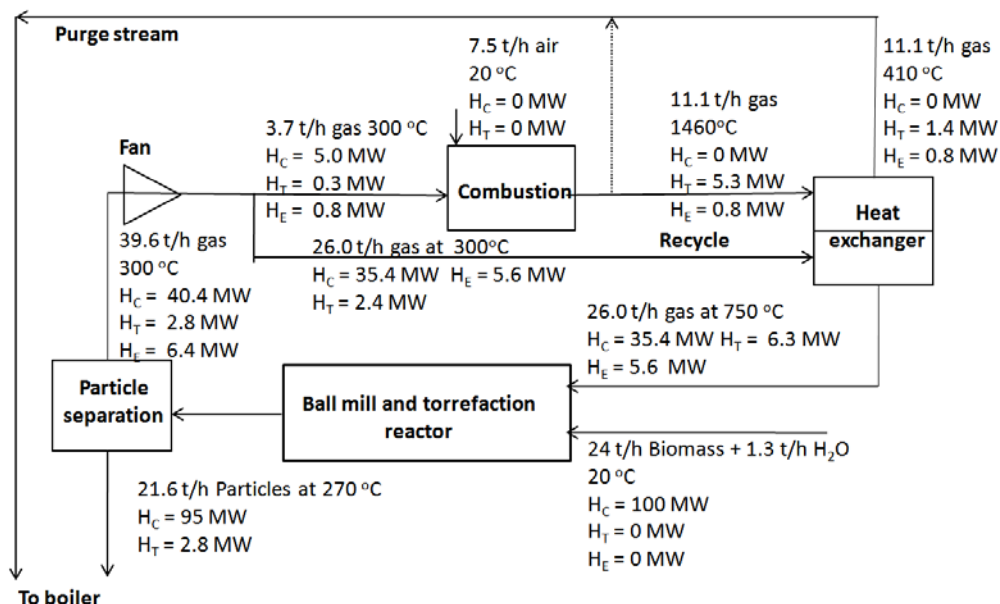

Figure 2: Mass and energy flow for torrefaction of biomass with 5 wt. % moisture at 270 °C (Design 1).

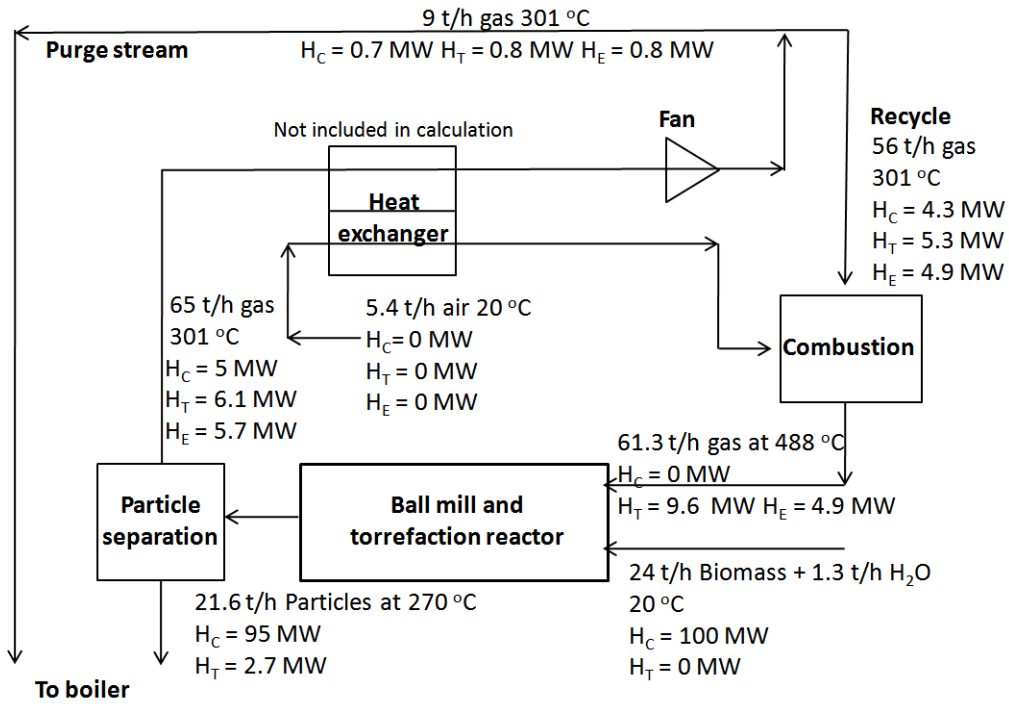

Figure 3: Mass and energy flow for torrefaction of biomass with 5 wt. % moisture at 270 °C (Design 2).

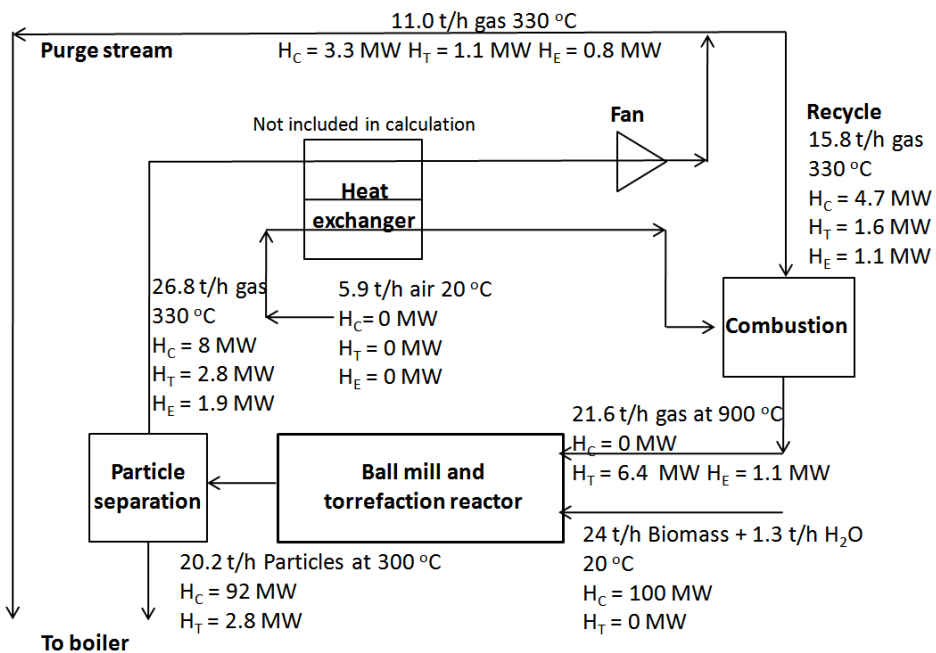

Figure 4: Mass and energy flow for torrefaction of biomass with 5 wt. % moisture at 300 °C (Design 2).

The solution procedures used for the 2 designs are summarised below:

- Design 1:

The recycle gas flow is calculated based on the energy demanded in the torrefaction reactor (solid heating and evaporation of water) and the assumed torrefaction reactor inlet and outlet gas temperatures (750 and 300 °C respectively). The amount of gas and water vapour released in the torrefaction reactor must be balanced by the purge flow. The purge flow is removed from the gas stream leaving the combined ball mill and torrefaction reactor and led to the boiler.

- Design 2:

The recycled gas flow is calculated by an iterative procedure, where each estimate of the flow and thereby also the purge percentage will be evaluated based on the energy demand in the torrefaction reactor (solid heating and evaporation of water) and an assumed outlet gastemperature of 300 or 335 °C. The purge percentage is the sum of air addition and gas released by torrefaction divided by the estimated total flow. To simplify the calculation the energy exchanged between the torrefaction gas and the air will not be included in the calculation (the heat exchanger). The purge flow (the fraction of gas removed from the gas stream leaving the combined ball mill and torrefaction reactor system) is determined by the gas/water vapour released in the reactor and the air supplied for the partial combustion. The influence of the simplification regarding heat exchange has been tested for torrefaction at 300 °C and it causes an overestimation of the recycle/purge stream temperature of 70 °C and a 20 °C underestimation of the recycle stream temperature after combustion.

When comparing the two plant designs for torrefaction at 270 °C (figures 2 and 3), design 1 require the lowest gas stream recycled to the reactor for biomass heating (26 t/h compared to 61 t/h) and thereby the smallest reactor dimensions This is because design 1 utilise both thermal energy and combustibles from the purge stream for heat exchange with the gas stream recycled to the reactor. Design 2 on the other hand will purge some combustibles to the boiler (a substantial purge flow is required because of the air addition to the recycle stream) and this increases the required recycle flow (to decrease the percentage combustibles lost) thereby making the design more dependent on the energy content of the gas released by torrefaction. The partial combustion in design 2 will limit the concentration of combustibles in the recycle stream compared to design 1, where a considerable concentration of combustibles is recycled (corresponding to 35.4 MW). However, considering the limited temperature rise predicted for the recycled flow in design 2 (180 °C) it is questionable whether this is combustible without the use of an oxidation catalyst.

Performing the torrefaction at a higher temperature will increase the amount of energy released to the gas phase during torrefaction and thereby the heating value of the mixture of torrefaction gas and evaporated moisture. For design 2 a 30 °C torrefaction reactor temperature increase (to 300 °C) will drastically decrease the needed recycle stream (from 56 t/h to 16 t/h). The heat exchange of the torrefaction gas before the fan in design 2 will limit the temperature the fan is exposed to and thereby its durability. As previously mentioned this causes an overestimation of the recycle/purge stream temperature of 70 °C and a 20 °C underestimation of the temperature of the recycle stream after combustion for torrefaction at 300 °C, while no significant differences is seen at 270 °C because of the high recycle stream.

The pipe diameter capable of transporting the required 21.6 ton/h and 900 °C gas stream to the torrefaction reactor (design 2 for torrefaction at 300 °C) at 20 m/s will be in the range 2.0 m (equation 3)

$$D = 2 \cdot \sqrt{\frac{m}{\rho \cdot v \cdot \pi}} = 2 \cdot \sqrt{\frac{\frac{21600 \text{ kg}}{3600 \text{ s}}}{\frac{28 \text{ g/mol} \cdot 1 \text{ atm}}{0.08206 \frac{\text{L} \cdot \text{atm}}{\text{mol} \cdot \text{K}} \cdot 1173 \text{ K}} \cdot 20 \frac{\text{m}}{\text{s}} \cdot \pi}} = 2.0 \text{ m} \quad [3]$$

Heat transfer and reactor dimensions

Figure 5 illustrates the basic outline of a potential torrefaction reactor system with integrated grinding. The raw biomass is feed into the rotating kiln, where final drying, heating and low temperature pyrolysis takes place. The heated biomass is more brittle and the presence of metal balls causes grinding of the biomass to a product size of less than 1 mm. In the following it will be assumed that the particles will be grinded when they reach a temperature of 270 °C, the fine particles formed will then be entrained by the gas flow and exit the reactor. This study will focus on heating of the bed material by a hot gas stream, but heating through the reactor walls is another possibility. With the assumption of instantaneous grinding of the pyrolysed particles the reactor dimensions will be determined by either the heat transfer to the bed, heat transfer within the bed or heat conduction within particles for a given feed rate and particle size. The slow and steady rotation of industrial kilns ensures a good particle mixing and temperature distribution within the bed [Li, et. al., 2005], this will only be enhanced by the swifter rotation of a combined torrefaction and grinding unit (in order to facilitate grinding). The influence of heat transfer to the bed (external heat transfer) and heat conduction within particles (internal heat transfer) will be covered in greater detail in the next sections.

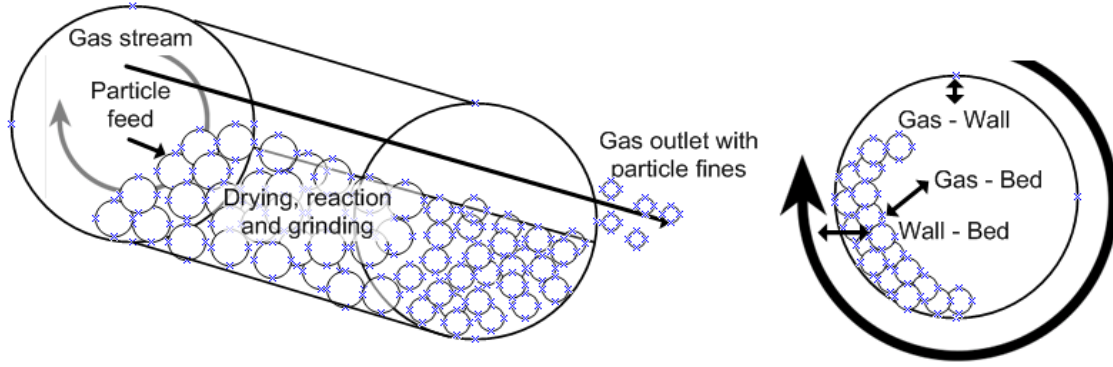

Figure 5: Torrefaction reactor outline (left) and modes of heat transfer (right)

Internal particle heat transfer limitations

The influence of internal particle heat transfer will be evaluated based on the one-dimensional heat conduction within single spherical particles. The results will depend on the heat transfer to the particle surface, which could be described as gas to single particle heat transfer, gas to bed heat transfer or heat transfer from the bed to a single particle (in a fluidized bed) - as a conservative estimate the gas to bed heat transfer coefficient will be used on these calculation ($h_{\text{gas to bed}}$). Equation 4a describes the transient and internal development of particle temperature due to heat conduction in spherical coordinates. This equation can be expressed as a dimensionless temperature increase (equation 4b) based on Fourier's number ($Fo = \alpha \cdot t / R^2$), Biot's number ($Bi = h R / k_b$), the thermal diffusivity of wood ($\alpha = k_b / (\rho \cdot C_p)$), the thermal conduction coefficient of wood (k_b), the heat transfer coefficient, the particle radius (R) and time (t) – for parameter values see figure 6 [Green, 2008; Cengel, 2008]. The diffusion of water within the particles during drying will not be included, but energy required to heat and evaporate water is included in the heat capacity (see calculation of heat capacity and thermal diffusivity in equation 5).

$$\frac{\partial T}{\partial t} = \frac{\alpha}{r^2} \cdot \frac{\partial}{\partial r} \left(r^2 \cdot \frac{\partial T}{\partial r} \right) \quad T(r,0) = T_i \quad \frac{\partial T(0,t)}{\partial r} = 0 \quad -k \cdot \frac{\partial T(R,t)}{\partial r} = h(T - T_\infty) \quad [4a]$$

$$\rightarrow \frac{T(r,t) - T_i}{T_\infty - T_i} = \sum_{n=1}^{\infty} \frac{4(\sin \lambda_n - \lambda_n \cos \lambda_n)}{2\lambda_n - \sin(2\lambda_n)} \cdot e^{-\lambda_n^2 \cdot Fo} \cdot \frac{\sin(\lambda_n \cdot r / R)}{\lambda_n \cdot r / R} \quad [4b]$$

with λ_n being the roots of $1 - \lambda_n \cdot \cot \lambda_n = Bi$

Figure 6 shows the transient development in internal temperature distribution for 1, 10 and 25 mm particles. Initially considerable internal temperatures gradients are observed for 10 and 25 mm particles. As the final temperature is approached the gradients becomes much less pronounced and an assumption of a uniform particle temperature can be reasonable for this later part of the heating process.

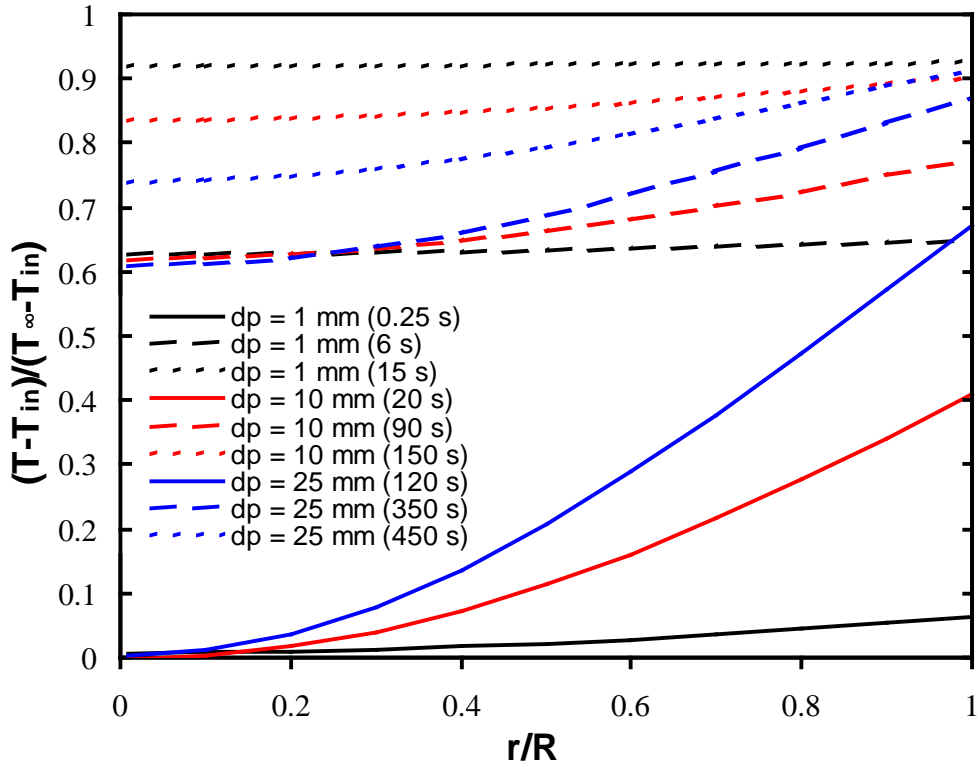

Figure 6: Transient development in internal temperature distribution for 1, 10 and 25 mm particles with 5 % H_2O . Thermal conduction coefficient of wood (k_b) = 0,175 W/m K (at 150 °C) [Babu & Chaurasia, 2004], heat transfer coefficient $h = 42$ W/(m^2 K) (see equation 7), density = 650 kg/ m^3 [Babu & Chaurasia, 2004] and solid heat capacity (including enthalpy for water evaporation) $C_{p^*} = 2220$ J/(kg K) (5 wt. % H_2O see equation 5). Based on these material properties the thermal diffusivity of wood (α) can be calculated to be $1.21 \cdot 10^{-7}$ m^2/s (see equation 5) [Babu & Chaurasia, 2004]

$$\rightarrow \alpha = \frac{0.175 \frac{W}{m \cdot K}}{650 \frac{kg}{m^3} \cdot (0.95 \cdot 1840 + 0.05 \left(\frac{1000 \cdot 100}{250} + \frac{2260 \cdot 10^3}{250} \right) \frac{J}{kg \cdot K})} = 1.21 \cdot 10^{-7} \frac{m^2}{s} \quad [5]$$

Equation 4b can also be used calculate the time required to heat the centre of the particle within for example 5 % of the final temperature (i.e. the centre temperature has increased to 95 % of $T_\infty - T_i$). The times required to heat the centre of a range of particle sizes is presented in Table 1, alongside the reactor volume (equation 6) required to treat 24000 kg/h dry biomass particles at 20 % volumetric reactor loading in the case of internal particle heat transfer control (i.e. swift heat transfer from wall/gas to the bed, negligible reaction time and instantaneous grinding).

$$V = \frac{m \cdot t_{dp,95\%}}{\rho} \cdot \frac{1}{0.2} = \frac{1.05 \cdot 6.67 kg / s \cdot t_{dp,95\%}}{650 kg / m^3} \cdot \frac{1}{0.2} \quad [6]$$

Table 1: Time required to heat particle centre within 5 % of final temperature

Particle diameter [mm]	10	25	50
Heating time [s]	237	857	2635
Reactor volume [m ³]	13	46	142

The heating/residence times and reactor volumes to process 25300 kg/h biomass particles (5 wt. % moisture) is relative short/small when particles with diameters below 25 mm are used.

External heat transfer limitations

The influence of heat transfer from the gas phase to the bed material will be evaluated in this section based on heat transfer coefficients for rotary kilns obtained from the literature. As illustrated by figure 5 heat transfer may take place from gas to bed, wall to bed and between wall and gas. This section will focus on the gas to bed heat transfer (though a fraction of the particles exposed to the gas phase) because of the high heat transfer coefficients that can be obtained by this relative simple mechanisms (heating by a gas phase as opposed to heating the wall of the rotating reactor). Based on the low torrefaction reaction temperature (270 and 300 °C) heat transfer by radiation is assumed negligible, and only heat transfer by convection will therefore be covered. The convective gas to bed heat transfer coefficient in a rotating kiln can be estimated by equation 7 [Boateng, 2008] based on the gas density at a mean temperature of 615 °C and an assumed gas velocity of 1.3 m/s – corresponding to a gas flow of 21.6 t/h for a 20 % filled reactor with a diameter of 4.35 m)

$$h_{eb} = 0.4 \cdot \left(v_g \cdot \rho_g \cdot 3600s/h \right)^{0.62} \quad [7]$$

$$\rightarrow h_{eb} = 0.4 \cdot \left(1.3 m/s \cdot \frac{28 g/mol \cdot 1 atm}{0.08206 \frac{L \cdot atm}{mol \cdot K} \cdot \frac{1173 + 603}{2} K} \cdot 3600s/h \right)^{0.62}$$

$$\rightarrow h_{eb} = 42 \frac{W}{m^2 \cdot K}$$

Based on the gas inlet and outlet temperatures for design 2 (from the mass and energy balance established previously – shown in Figure 4), an assumed uniform bed temperature of 300 °C and co current flow, the average temperature difference from gas to bed surface can be determined by equation 8.

$$\Delta T_m = \frac{\Delta T_i - \Delta T_u}{\ln \frac{\Delta T_i}{\Delta T_u}} = \frac{(T_{g,in} - T_s) - (T_{g,out} - T_s)}{\ln \frac{T_{g,in} - T_i}{T_{g,out} - T_s}} = \frac{(900 - 300) - (330 - 300)}{\ln \frac{(900 - 300)}{(330 - 300)}} = 190^\circ C \quad [8]$$

The surface area required for gas to bed heat transfer can then be calculated from equation 9, based on the energy requirement for heating dry biomass (equation 2), the heat transfer coefficient (equation 7) and the average temperature difference from gas to bed surface (equation 8).

$$A = \frac{Q_{dry_feed}}{h \cdot \Delta T} = \frac{(3.98 + 0.37) MW}{42 \frac{W}{m^2 \cdot K} \cdot 190^\circ C} \quad [9]$$

$$\rightarrow A = 545 m^2$$

The heat transfer area available will depend on the bed motion – i.e. whether the rotation of the vessel is swift enough to facilitate contact between the gas and individual particles or if the contact area will only be the exposed bed surface. The bed motion can be evaluated based on the ratio of the angular velocity (N) and the critical angular velocity (N_c, determined by equation 10), where centrifugation starts (particles are carried along the wall during the entire rotation circle) [Tscheng & Watkinson, 1979].

$$N_c [RPM] = \frac{42.31[\sqrt{m} / \min]}{\sqrt{D[m]}} \quad [10]$$

Slow rotating industrial kilns usually fall in the rolling regime (N/N_c < 0.1), where a thin layer of particles rolls down the wall [Tscheng & Watkinson, 1979]. Ball mills, such as the concept outlined above, are however operated at much higher velocities (N/N_c from 0.65 to 0.8), which will facilitate a cascading particle motion and thereby a much better contact between gas and individual particles [Neikov et. al. 2009]. Considering the expected cascading particle motion the heat transfer area will be evaluated based on the surface area of a fraction of individual particles. The required heat transfer area of 545 m² corresponds to a surface area that can be provided by 2950 kg 50 mm particles (see equation 11), which just corresponds to 12.0 % of the hourly biomass feed rate.

$$m = \frac{A}{4 \cdot \pi \cdot r^2} \cdot \left(\frac{4}{3} \cdot \pi \cdot r^3 \right) \cdot 650 \frac{kg}{m^3} \quad [11]$$

Assuming a 20 % solid loading and that 20 % of the particles are in tight contact with the gas phase at any given time the reactor volume (calculated by equation 12) becomes 113 m³ for 50 mm particles, somewhat lower than the reactor volume calculated based on internal particle heat transfer (142 m³,

and 2635 s (Table 1)). The reactor volume calculated for 50 mm particles (based on $V = 142 \text{ m}^3$) corresponds to a 9.5 m long ($D = 4.35 \text{ m}$) cylindrical rotating kiln operating at a 20 % loading.

$$V = \frac{m}{\rho} \cdot \frac{1}{\text{Contact\%}} \cdot \frac{1}{\text{loading\%}} \quad [12]$$

Further initiatives to improve the gas/particle contact, such as passing the gas through the bed material, using baffles etc. may increase the contact area, but the internal particle heat transfer resistance will likely limit the benefits.

Conclusion

The low temperature torrefaction pre-treatment process for biomass, improves fuel properties, such as grindability and stability/storability. This study investigate the use of a heated ball mill in which both the grinding and torrefaction takes place. The heating of the biomass is performed by combustion of evolved torrefaction gasses and subsequent heating of the biomass by a heat exchanged recycle stream (Design 1) or directly by the combustion gas (Design 2). In design 1 a part of the gas leaving the torrefaction reactor is purged from the recycle loop and combusted thereby supplying heat (transferred by a heat exchanger) to the oxygen free recycled gas, which is led to the reactor. Design 2 heat exchange the gas leaving the torrefaction reactor with the air for partial combustion of the recycled gas and then purge part of the torrefaction gas before performing the partial combustion of the recycled stream (sub-stoichiometric air to fuel ratio, to ensure that no oxygen enters the reactor). This supplies heat for the recycle, which is led directly to the torrefaction reactor.

Mass and energy balances for the 2 potential torrefaction process designs, closely integrated with a nearby power plant (supply of hot flue gas and pulverized biomass to maximize efficiency) have been established. The mass and energy balances have been set up for a 100 MW biomass input with 5 % moisture (25260 t/h), based on torrefaction data for spruce from [Saleh et al., 2013] and assuming negligible energy contributions from hemicellulose decomposition and decomposition of lignocellulosic compounds. Table 2 summaries the main design data for the 3 cases studied (Design 1 at 270 °C, design 2 at 270 °C and design 2 at 300 °C). For torrefaction at 270 °C, the lowest recycle stream is obtained for design 1, because both thermal energy and combustibles from the purge stream is utilised for heat exchange with the gas stream recycled to the reactor. Design 2 on the other hand will purge some combustibles to the boiler (a substantial purge flow is required because of the air addition to the recycle stream) and this increases the required recycle flow (to decrease the percentage combustibles lost) thereby making the design more dependent on the energy content of the gas released by torrefaction. A minor temperature increase (to 300 °C) will increase the heating value of the mixture of torrefaction gas and evaporated moisture and thereby drastically decrease the recycle stream for design 2 (from 56 t/h to 16 t/h).

The swift rotation of the suggested combined torrefaction and ball mill unit is expected to ensure a cascading particle motion and a good particle gas contact. The reactor volume required to treat 25260 kg biomass/h will, for a particle size of 50 mm, be determined by internal heat transfer resistance, with reasonable reactor dimensions ($L = 8.0$ m, $D = 4.75$ m and $V = 142$ m³) and considerable solid residence times (app. 2635 s) in the case of heating of the bed material by a 900 °C (inlet temperature) gas phase flowing at 1.3 m/s (Design 2).

Table 2: Selected design data for the 3 cases studied ($d_p = 50$ mm)

Design		1	2	2
Temperature	°C	270	270	300
Gas recycle for heating	t/h	26	56	16
Purge stream	t/h	11	9	11
Purge stream temperature	°C	410	301	330
Purge stream combustibles	MW	0	0.7	3.3
h_{eb}	W/m ² K	42	42	42
Heat transfer resistance	-	Int.	Ext.	Int.
Reactor volume	m ³	142	206	142
Reactor diameter*	m	4.8	7.3	4.35
Reactor length	m	7.8	4,9	9.5

*The reactor diameter has been varied to obtain the same heat transfer coefficient in all cases (affects the velocity and h_{eb} , see equation 7)

Literature

- Babu, B.V.; Chaurasia, A.S. Parametric study of thermal and thermodynamic properties on pyrolysis of biomass in thermally thick regime. *Energy Conversion and Management*, 45(1); pp 53-72, **2004**
- Bates, R.B.; Ghoniem, A.F. Biomass torrefaction: Modelling of reaction thermochemistry. *Biomass Technology*; 134; pp. 331-340, **2013**,
- Boateng, A.A. *Rotary kilns – Transport Phenomena and Transport Processes*, Butterworth Heinemann, **2008**.
- Cengel, Y.A. *Heat and mass transfer – a practical approach 3rd edition*, McGraw-Hill, **2007**.
- Haynes, W.M., ed. *CRC handbook of Chemistry and Physics 92nd edition* (Internet version 2012), CRC Press/Taylor and Francis, Boca Raton, FL, **2012**.
- Green, D.W., ed. *Perry's chemical engineers' handbook 8nd edition*, McGraw-Hill, **2008**
- Li, S.Q.; Ma, L.B.; Wan, W and Yao, Q. A Mathematical Model of Heat Transfer in a Rotary Kiln Thermo-Reactor. *Chemical Engineering and Technology*; 28(12); pp. 1480-1489, **2005**,
- Neikov, O.D; Naboychenko, S.; Mourachova, I.B.; Gopienko, V.G.; Frishberg, I.V.; Lotsko, D.V. *Handbook of Non-ferrous Metal Powders: Technologies and Applications*, Elsevier, **2009**.
- Saleh, S.B; Hansen, B.B.; Jensen, P. A.; Dam-Johansen, K. Efficient Fuel Pretreatment: Simultaneous Torrefaction and Grinding of Biomass. *Energy & Fuels*, **in press**
- Tscheng, S.H.; Watkinson A.P.. Convective Heat Transfer in a Rotary Kiln. *The Canadian Journal of Chemical Engineering*; 57, pp. 433-444, **1979**,