

Design of a Releasable Snowboard Binding

Submitted to:
The Faculty of the Department of Mechanical Engineering
and
Bob Zider

by

Rex Crossen
Brian Kruse
Timothy Scott

Date: June 4th, 2012

Project Advisor: Dr. Mello

Instructor's Comments:

Instructor's Grade: _____

Date: _____

Design of a Releasable Snowboard Binding

by

Rex Crossen
Brian Kruse
Timothy Scott

Mechanical Engineering Department
California Polytechnic State University

San Luis Obispo

Spring 2012

Statement of Disclaimer

Since this project is a result of a class assignment, it has been graded and accepted as fulfillment of the course requirements. Acceptance does not imply technical accuracy or reliability. Any use of information in this report is done at the risk of the user. These risks may include catastrophic failure of the device or infringement of patent or copyright laws. California Polytechnic State University at San Luis Obispo and its staff cannot be held liable for any use or misuse of the project.

TABLE OF CONTENTS

Topic	Page #
1. ABSTRACT	1
2. INTRODUCTION	2
3. BACKGROUND	
• K2 Clicker Binding	3
• Flow Rear-entry Binding	3
• Revolution Impact Release Binding	3
• Deft Sports Ejection Binding	3
• Winchester Polytechnic Impact Release Binding	4
• Winchester Polytechnic Releasable Binding	4
• Home-made Lanyard Release Binding	5
• Front Foot Swivel Devices	5
• Improved Strap Technology	5
• Cant Technology	6
• State of the Art	6
4. Formal Problem Definition	7
5. Objective/Specification Development	8
6. Specific Technical Data	9
7. PROCEDURE	
• Quality Functional Deployment	10
• Design Development and Concept Generation	11
• Decision Matrix for Motion for Release	11
• Decision Matrix for Motion for Re-entry	12
• Concept #1: Additional Stomp-in Plate	13
• Test Apparatus for Foot Strength	13
• Concept #2: Kick-in Binding	14
• Concept #3: Modified Ski Binding	14

8. Final Design Description	
• Description	15
• Initial Prototype	16
• Final Prototype	16
• Safety Considerations	17
9. Analysis Results	
• Spring Constant Calculations	18
• Finite Element Analysis	18
10. Cost Analysis	
• Price Breakdown	20
• Machined Parts	20
11. Manufacturing	
• Final Prototype Manufacturing	21
• Future Manufacturing Plans	22
12. Design Verification Plan	21
• Testing Plan	23
• Actual Testing	23
13. Conclusions and Recommendations	
• Conclusions and Recommendations	25
• Economics and Marketing	26
14. REFERENCES	27
15. APPENDIX	
• Appendix A: QFD	28
• Appendix B: Detailed Spring Constant Analysis	29
• Appendix C: Gantt Chart	30
• Appendix D: Detailed SolidWorks Drawings	
a. Exploded View of Assembly	31
b. Exploded View of Cam	32
c. Cam – Top	33
d. Cam – Middle	34

e. Cam – Middle Profile	35
f. Cam – Bottom	36
g. Follower	37
h. Set Screw Insert	38
i. Spring Aligner	39
j. Base Plate	40
k. Base Plate – Section	41
l. Base Plate – Bottom	42
m. Base Plate – Hole Pattern	43
n. Top Plate	44

List of Figures

Figure 1: K2 Clicker Bindings
Figure 2: Flow Rear Entry Binding
Figure 3: Deft Sport’s Ejection Binding
Figure 4: WPI’s Safety Release Binding
Figure 5: WPI’s Releasable Binding
Figure 6: Flip U Device for Changing Footing
Figure 7: Ride’s V-strap Contraband Binding
Figure 8: Rome’s “Yes I Cant”
Figure 9: Section View of Stomp In plate
Figure 10: Torque Test for Twist Motion
Figure 11: Kick-In Binding
Figure 12: Modified Ski Binding Concept
Figure 13: Final Design in SolidWorks
Figure 14: Exploded View of Final Design in SolidWorks
Figure 15: Initial Rapid Prototyped Cam Fixed to the Bottom of a Binding
Figure 16: Initial Rapid Prototyped Baseplate with Springs, Followers, and Set Plates
Figure 17: Final Rapid Prototyped Baseplate with Machined Spring Assembly
Figure 18: Final Machined 3-piece Cam System with Notch
Figure 19: Applied Pressure on Bottom of Cam
Figure 20: Location of Stress Concentrations on a Cam Profile
Figure 21: Final rapid prototyped baseplate with spring assembly
Figure 22: Final machined spring assembly with milled edges, press-fit aligners, and sanded follower tip
Figure 23: 3-Piece machined cam attached to bottom of a binding

List of Tables

Table 1: Unique Motion for Binding Release
Table 2: Unique Motion for Binding Re-entry
Table 3: Final inputs to calculate torque range of 107-199 lb-in

Table 4: Comparison of von mises stresses at stress concentrations to aluminum yield stress

Table 5: price breakdown of Unbound Binding components

Table 6: Machined parts from aluminum rod and bar

ABSTRACT

A releasable snowboard binding will be proposed to Bob Zider. This binding will allow the user to release and engage on demand for aerial tricks, comfort, and increased safety. The releasable snowboard binding we will come up with will be revolutionary within the snowboard industry and make current bindings seem old and inferior.

INTRODUCTION

Bob Zider came to us with the problem of engineering a releasable snowboard binding. As an entrepreneur and innovator, he has been involved with many projects over the years. His interest in snowboarding unfortunately stemmed from his son's death roughly 20 years ago. He was posed with the question of whether he should go on a crusade against snowboarding or take it up to see what kept his son coming back for more. After skiing for many years, he decided to see what it was like. After going down a back country slope over fresh powder, not only did he understand what drew his son and other snowboarders to these dangerous but amazing places, but he also loved it. Even though it's been 20 years since his son's death, he has watched the market and the equipment over the years change. Bob realized that a lot of technology has changed on the boards but very little has been done over the years to the bindings themselves. Small changes have been made but they are still essentially the same "bear trap" that keeps snowboarders locked to the board in dangerous positions whether the snowboarder likes it or not. This problem leaves room for advancement in binding technology.

When dealing with a sport like snowboarding where the rider is fueled by the adrenaline from riding down the mountain at quite literally breakneck speeds, going down slopes of fresh powder never boarded on before, and soaring off jumps to do aerial maneuvers, Bob knows that safety won't sell. Technology that will allow the user to release when in danger or a potentially hazardous situation already exists. The problem is in extreme sports safety doesn't sell: "cool" does. We need to come up with an idea that revolutionizes the industry and makes current bindings look archaic. Bob envisions a binding that will allow the user to release both feet from the board so that the user can grab the board similar to a skateboard maneuver and then land back on it which would re-engage the bindings, letting the rider to smoothly board away. He feels that this is the next step for snowboarding because other extreme sports allow the user to release from their equipment to perform maneuvers in the air. This is the cool factor that will sell the binding; our job is to make it safe. This product will sell safety as a byproduct of being cool.

Bob was dissatisfied with current products and decided to hold a design competition for releasable bindings that fit his idea. Though many of them were satisfactory in that they allowed the user to do a hands free release, few of them had the cool factor to draw consumers to them and allowed the user to re-engage back to the board.

BACKGROUND

We did background research to see the different technologies currently being done with snowboards to make them release and swivel in addition to a few other items that companies have done to modify their bindings. We found many different “easy in” bindings, but found few things that would allow the rider to release. We inspected products from K2, Flow, and Revolution; senior projects from Worcester Polytechnic Institute (WPI); binding swivel technology from multiple companies; and a type of homemade release technology. We also looked at other modifications in strap technology from Ride and Flow and another type of technology called cant that changes foot orientation from Flow and Rome.

K2 came out with new technology that seemed revolutionary in that the rider only had to step into the binding and easily click out to release. Issues arose when the base was covered with ice and snow preventing the boots from locking in and sometimes locking the user to the board in addition to the fact that the boots were uncomfortable because they had to overcompensate for the lack of support of the binding, so intermediate to advanced riders chose to go with the standard bindings. They were popular for rentals but this doesn't encompass most of the market.



Figure 1. K2 Clicker Bindings

Flow, another company, had another type of step in binding called a rear entry binding. These bindings appear to be normal bindings with the exception that the highbacks rotate down so the user can enter and exit the binding without ratcheting or un-ratcheting the straps, but these also don't release without the use of hands.



Figure 2. Flow Rear Entry Bindings

Revolution has a special type of binding that releases the user on high impacts so that the user will be released during a fall. This is not what Bob is looking for because it doesn't allow the user to release on demand, doesn't allow the rider to reengage their foot, and only releases on a fall.

Additionally, Deft Sports is developing an impact release binding. Very little information is given on their website about the specifics of their product other than it is supposed to reduce injuries.



Figure 3. Deft Sport's Ejection Binding

While researching, we found two senior projects from WPI that attempted to improve on the safety of snowboarding. The undergraduate projects both designed a releasable binding. One project analyzed impact release bindings to prevent upper body injury while the other attempted to create a binding that released on-demand. Both were hands-free releasable snowboard bindings.

In 2007, the undergraduate students at WPI focused on creating a snowboard binding that prevents upper body injury from the “flyswatter effect”, a dangerous movement which occurs when riders catch a longitudinal edge of the snowboard during turns and are then propelled toward the ground. The students had three main goals when starting the project. To release under a shear force just under that of the “flyswatter effect”, a moment lock system that prevented inadvertent release, and an adjustable preloading system for the binding. In research for their project, they looked into tests that analyzed forces and stresses from snowboarding. They had trouble designing because there is very little data out on the forces and moments during snowboarding. Testing the multitude of different scenarios for snowboarding is very difficult, time consuming, and costly, which is why minimal data is available. Even with this challenge, the undergraduate students were still able to design, construct, and test their binding system. They went through several generations of designs as they went back and tweaked their original ideas. They were limited to lab testing due to the dangers of equipment failing in the field. While somewhat inconsistent, their tests were successful and allowed the binding to release around the desired shear stress. Unfortunately, the moment lock release system did not function as well as intended. For our group’s project at California Polytechnic Institute, we have a broader goal and scope for our project, but an impact release system is something that we may consider but is not a requirement from Bob.

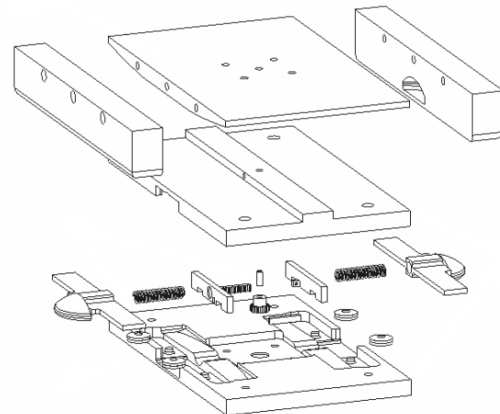

Figure 4. WPI's Safety Release Binding

In 2009, a new team of WPI students again addressed the current problem of releasable snowboard bindings. This team focused on creating a new binding that released on-demand when rotated. They noted in their report that products currently exist that allows the rider to rotate or release the binding; the team’s objective was to combine both qualities in one easy-to-use, comfortable binding. The final design used a circular cam and follower system placed inside the bottom plate. With V-shaped notches in the cam and a dual spring preloaded system, the binding remained stable, reducing wobble to attempt to

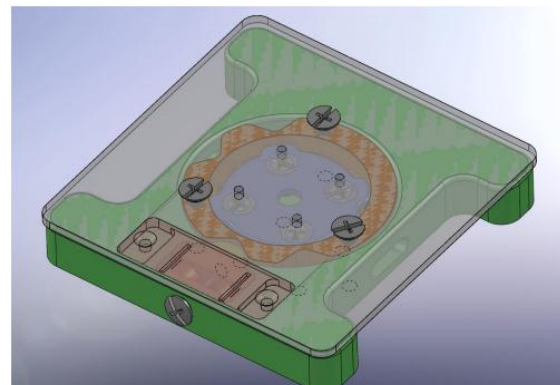

Figure 5. WPI's Releasable Binding

provide the same feel as a standard binding system. The team used statics to determine that at a torque of 15 N-m the rider will be able to rotate and release the binding. They designed a bottom plate (aluminum, weight=2.44 pounds, height=0.98 in.) that attaches to existing snowboards. Using finite element analysis, the team supplied two figures for each piece that displayed its deflection and stress. The team manufactured and tested their final design before the snow season was over in March 2009. They separated their testing into six parts with each sequential part using more aggressive snowboarding techniques. The users reported that it felt almost identical to the current plate and binding system, and there was only one report of inadvertent release and rotation which was during the most aggressive riding test. One main problem that the team faced was ice and debris buildup in the binding plate. This contamination greatly changed the function of their binding, making the torque for rotation very high. They noted that future iterations of their design would focus on reducing weight, height, and providing superior protection to snow and dirt.

Some owners have created their own makeshift releasable binding that utilizes a lanyard that is strung through the release part of the ratchet on the top binding strap. A video on YouTube shows a retrofit that someone does on their existing bindings. This addition makes it so that if the user was stuck in snow and couldn't reach the bindings with their hands, the cord could be pulled which would allow the boots to be released without having to bend over to un-ratchet as is usually done.

There has been a recent push in the industry for a way to allow the user's front foot to rotate to be parallel to the board to make it easier to "skate". Many companies have a nearly identical product in that there is a plate under the front binding that has a release mechanism which will disengage a lock that keeps the binding stationary. Some of these products allow the foot to only rotate 90 degrees, but others allow a full 360 degree rotation. Additionally, some products have a plate under each binding which allows rotation of both feet and keeping both feet at the same ride height which will improve the ride feel in addition to reducing back and hip pain.



Figure 6. Flip U device for changing footing

In addition to the different ways that the foot is placed in the binding, improvements on straps have made. Ride uses a type of strap they called the V-Grip strap that uses one ratchet on the ankle strap with a V strap that attaches to encompass the toe for ease of entry while maintaining ankle and toe support. Flow also has a different type of strap they call a "Powerstrap" that can be seen in Figure 2. It essentially connects the ankle and toe straps to create more surface area that spreads the pressure out over the boot and gives more control while the boarder is toe side.



Figure 7. Ride's V-Strap Contraband Binding

A few companies (Rome's "Yes, I Cant" and Ride's "Wedgie" for example) have added a wedge, called a cant, on the binding that raises the outside of the foot. This is supposed to give the rider bigger ollies and increase turning response.



Figure 8. Rome's "Yes I Cant"

When doing research on previous snowboard bindings and equipment we were unable to find anything on auto release bindings so we ended up looking past the snowboard market and did research on products in other industries that seemed to suit our needs. The first thing we looked at was ski bindings as it was the pre-cursor to the snowboard. Ski bindings weren't always auto release, in fact you used to be stuck to the skis just as current snowboards are. For a long time leather straps were used to keep the boots attached to the skis and they were later replaced with metal cables. Both designs didn't allow for auto or impact release, which was a big concern as skiing was becoming more and more dangerous. It wasn't until 1965 that Solomon came out with the 505 binding and the industry was revolutionized. The 505 is basically what all bindings are modeled after today. The bindings attach the boot at both the heel and toe to the ski. The bindings are adjusted based on height, weight and skill so that they release when a certain amount of torque is applied, allowing the skier to pop out upon falling. Though looking at the snowboard motion and how much torque is used to turn the board left and right we quickly realized this type of design wouldn't work.

The next type of locking mechanism we looked at was the mechanism on bike clips. Several different designs currently exist that allow the rider to smoothly clip in out of the bicycle pedals. Many of the pedal and shoe combos we researched allow the rider to attach to the pedal by stepping in and release by twisting out.

State of the Art

As has been shown, the state-of-the-art technology isn't any groundbreaking design. Changes implemented from one year's bindings to the next consist of minor improvements upon old technology. One example is moving the front strap over the toe and using lighter and stronger composites. Very little research is done to improve the overall design of bindings.

There are many aspects of current bindings that can be modified and combined to create a superior product. The current trend of using a top cap or toe strap is an excellent method of giving the rider more control and will definitely be implemented if we use strap technology. Additionally, rear-entry bindings may be modified to allow the user to "kick" back into the binding to lock back in. Impact release bindings found in skis and Revolution bindings will be looked at for implementation on either the front or both bindings. If able, we will also attempt to add in a swivel mechanism for the front foot for more aerial maneuvers.

FORMAL PROBLEM DEFINITION

A way to release and reengage the feet from the snowboard to perform aerial tricks and enhanced safety is needed. The sport of snowboarding is currently at stagnation in that nothing new is being done. Additionally, many snowboarders, including Bob's son, have been and will continue to be involved in fatal accidents because of being unable to release from their snowboard. We will develop a device to allow snowboarders to release and reengage from their snowboard on demand.

OBJECTIVE/SPECIFICATION DEVELOPMENT

Although Bob only had one design requirement, we still had to create specifications to the product had to meet based on limitations and usability. Our specifications stemmed from minimal ride change. We all agreed that riding the board with our product had to feel as close to possible to what people are already used to.

With this being set forth we decided that we needed to minimize the increase of the ride height. Keeping the user close to the board maintains a low center of gravity and maximizes the rider's transfer of energy to the board.

Additionally this idea of reducing the feel of the ride creates another limitation: we have a maximum for how long the length of the base can be. The base can't extend off the edge of the board. If the base extends off the board, it creates points for wear and friction because the snow will be rubbing against it. These hanging points could also potentially cause the rider to catch an edge poorly which may cause the rider to be propelled into the ground.

The other very important specification was keeping it lightweight. The intended users will be going off jumps and doing aerial tricks. Any weight we can minimize will improve the rider's experience. For our final design we will use plastics and composites for the primary body of the product. Some metal inserts will have to be implemented to prevent wear on the plastic components. We will also figure out where we can remove material to also make it lighter.

Our last specification came from our test method for determining the release torque. We had to find the torque that someone can exert by twisting their foot. This is covered in more depth later in the report.

SPECIFIC TECHNICAL DATA

The only technical data that we were able to find regarding the testing of products was on the ASTM website. There are seven different tests that can be used to test and certify snowboard bindings. The different tests are primarily for the different types of bindings. For instance step in bindings and strap bindings have two different tests. Since our product is something completely new we will ignore the tests for the time being as they don't quite apply. Though if we were to move forward with the product and maybe take it to market, it would be a must to look at and assess.

1.3 For snowboard boots interfacing with ski binding, see ISO 11634.

1.4 For snowboard plate bindings, see ISO 14790.

15. For snowboard strap bindings made for soft boots, see ISO 14573.

1.6 For snowboard step-in bindings, see ISO 15344.

PROCEDURE

We started out by doing research on current lock and release mechanisms so that we could possibly implement one or more of these as we see fit. We then considered each problem we wanted to address with our design, what the needs are for different styles of snowboarding (all mountain, freestyle, and back country), and the needs of the different skill levels. By formulating ideas to solve the problems for each case, we are then able to combine them to create a device for all boarders.

Quality Function Deployment “QFD”

Using a QFD helps our team to understand the problem and quantify customer requirements. We used QFD to establish exactly who our customers are and what they want from our product. We started by brainstorming a list of objectives that the product needed to do, what consumers will want, and what the product is comprised of. The finalized list was split into two categories: customer requirements and functional requirements. It was easy to make correlations between all of the different requirements by organizing these into their respective categories. The correlations included the relevance between requirements and how they were dependent among one another.

After creating all the customer requirements (What’s), we weighted them on importance. Our results after weighting each item showed that the most important customer requirements for our project are safety, reliability, minimal ride change, price, and being able to release. During our design process we need to focus on those five requirements the most in order to have a successful product.

Things we really need to pay attention to for the functional requirements (How’s) are cost, weight, and the amount of moving parts. We want to minimize the cost, so it’s more accessible to customers. We also want to reduce the weight. Snowboarders like lightweight bindings. One of the biggest factors though is the number of moving parts. Minimizing the number of moving parts will keep the product low maintenance and make it easier to fix if something does go wrong.

At the bottom of the QFD chart you can see the weight that each functional requirement holds, the relative weight, and how hard it will be to accomplish the task. This gives us an idea of how to move forward with the design keeping in mind the wants of the customer.

Also, the QFD spreadsheet gave us a visual aid which we will use to compare our final product to current types of bindings that are on the market. The products that we are going to be compared to are strap ins, Flow, leash release, and K2 bindings. We expect that when we rate our binding, it should score much higher with an unbiased review.

Design Development and Concept Generation

Our idea generation process stemmed from our problem statement, design requirements, and the information we extracted from our QFD, but the problem statement is the most important thing that we addressed: making a device that allows the user to release and re-engage from the snowboard on command. Each member of the group was responsible for innovating and thinking of ideas individually before moving to the group process. By doing this we weren't focused on the ideas submitted by each other and were able to keep an open mind to generate our own ideas.

During the group process we bounced ideas off each other and refined the designs that we came up with by ourselves. Additionally, we were able to generate more ideas together that used components from our individual idea generation process and completely new components we created together.

Decision Matrix

We created two decision matrices to determine which ideas are actually viable by analyzing their motion of release and re-entry. This allowed us to narrow our designs down and move forward with the design process.

Table 1. Unique Motion for Binding Release

	Ease of Motion	Leverage	Non-Interference w/ ride	Ease of Tricks	Sum
Heel-Toe	8	3	0	5	56
Twist In	7	3	6	6	85
Twist Out	6	3	6	6	81
Lift Outside of Foot	5	3	7	3	73
Lift Inside of Foot	3	3	8	5	76
Straight Up	8	3	3	8	80
Weight(0-5)	4	3	5	3	150

The most important factor for releasing is an easy unique motion of release that doesn't interfere with normal riding conditions. In other words the unique motion to release should not allow accidental release when normal carving is executed. From the results of the preliminary decision matrix, we determined to focus on binding designs that used either a twist or straight up motion for release.

Table 2. Unique Motion for Binding Re-Entry

	Self-Guiding	Short Time	Margin Of Error	Small Force	Sum
Heel-Toe	0	1	2	4	21
Kick In	6	9	5	4	85
Twist In	1	4	5	5	48
Twist Out	1	4	4	3	40
Press Outside of Foot	1	2	3	5	34
Press Inside of Foot	1	2	4	8	45
Stomp in	9	8	7	6	99
Weight(0-5)	3	5	2	3	130

We want to focus on creating a motion for a short time to re-attach to the snowboard. When doing aerial tricks, we want the rider to feel confident that quick and easy reattachment to the board can take place without fear of injury. The results from our second decision matrix for re-entry determined that a stomp in or kick in motion would be the best.

Our designs aren't mature enough to be compared to each other yet, but with sufficient analysis and testing, we will have a decision matrix to compare detailed concepts and choose a final design to prototype and test.

Concept #1: Additional Stomp-In Plate Idea

This idea utilizes a plate that is attached to the bottom of a binding and a base that is attached to the snowboard. The base has followers that are attached to springs. The plate attached to the bottom of the binding acts like a cam when releasing from the board and uses wedge action to reengage and lock in. The cutout on the plate for the followers to lock in is made in such a way to only allow movement in the release direction to prevent added movement that may be detrimental to the feel of the ride.

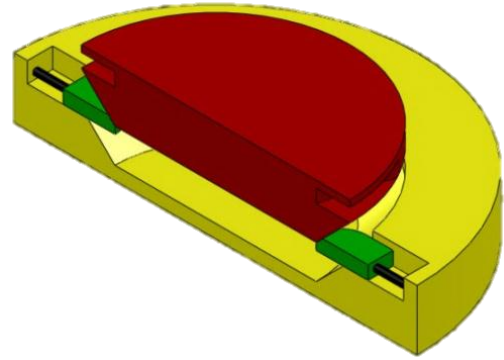

Figure 9. Section View of Stomp In Plate

The user twists their foot inwards to release the binding plate from the base. This motion will cause the followers to be pushed out of their grooves. Once out of the grooves, the user only needs to raise their foot to disengage from the board. To reengage, the user only needs to stomp their foot back in. The angled edges on both the plate and the follower gives rise to wedge action to push the followers back into place to reengage the rider to the board. Additionally the angled edges give the rider some room for error when trying to reengage in that the plate doesn't need to be perfectly aligned to reengage.

In order to find the correct spring constant, we will test the torque that the foot can apply. Our test will consist of a binding attached to a board that is attached to a Perfect Pushup. The Perfect Pushup gives us an axis of rotation we can rotate the foot about. We will then attach a spring or another type of sensor to the Perfect Pushup that will either measure the torque directly or measure the force at a distance from the center of the axis of rotation. These numbers will allow us to choose springs within a proper range for testing.

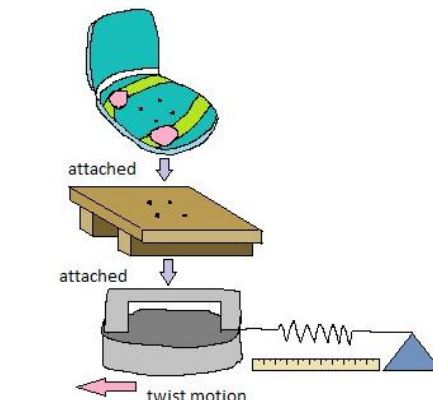

Figure 10. Torque Test for Twist Motion

We would also like to add magnets to the design as additional lock points. This should allow us to lessen the force on the springs. It will also make two different tests possible. The magnets can be removed to test the springs or remove the springs to test the magnets as locking points. By having a prototype that accomplishes more than one test, utilizing different components will save us time and money and should allow for much more extensive testing.

Concept #2: Kick-in Binding

This idea is unlike the previous in that the entire binding system stays attached to the board while the boot is released from the binding. It uses an L-shaped highback and a V-shaped strap. The highback is allowed to rotate backwards and one side of the strap is allowed to loosen. The highback and the V-strap will be

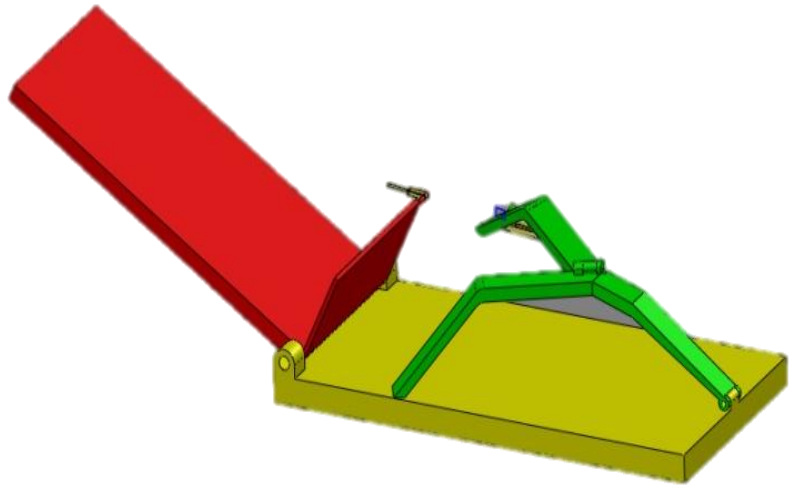

Figure 11. Kick-in Binding

connected by a system of cables that will tighten the V-strap when the highback is in the upright position and loosen the V-strap when in the rotated position.

To exit, the user has to perform a unique motion to initially loosen the V-strap. The user can then remove their boot from the binding which will lower the highback. To reengage, the user will kick their foot against the bottom plate of the highback. This action will raise the highback and position the foot inside of the binding. When the foot is fully in the binding, the highback will be in the upright position which will cause the V-strap to become tight. The challenge we face here as designers will come from finding a motion of the foot that will loosen the V-strap for initial release.

Concept #3: Modified Ski Binding

This design applies the idea of the releasable ski binding to snowboarding. As seen in the figure, we can modify existing technology of a ski binding and rotate 90 degrees. The snowboard binding connects to the board on the inside and outside of the foot. The rider is released by lifting either the inside of the foot, and a downward stomping movement allows the rider to re-enter.



Figure 12. Modified Ski Binding Concept

FINAL DESIGN DESCRIPTION

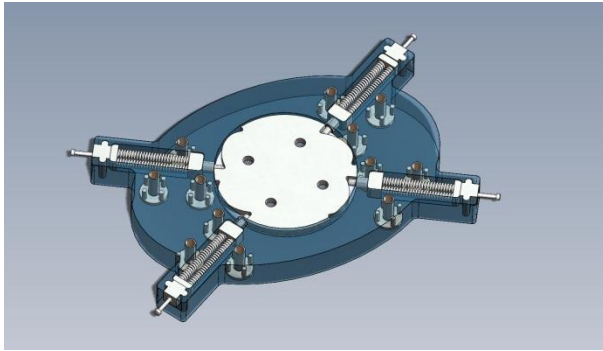

Figure 13. Final design in SolidWorks.

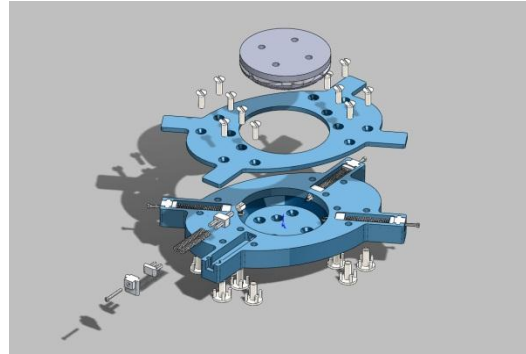

Figure 14. Exploded view of final design in SolidWorks.

Our final design is comprised of three main components: the base, cam, and the mechanical workings.

The base attaches to the snowboard and acts as the receiver to the cam which locks in as the followers find the cam profile. We have designed the base's bolt pattern to be compatible with both Burton's 3D setup and the conventional square pattern set up.

The other inlets in the base that are in the "X" shape pattern, hold the actual mechanical system of the binding which is comprised of springs, followers, set plates, and screws that keep the cam in place and allows for the release and reengage of the cam. These workings are then housed and covered by a top plate that keeps them in place and protected from the elements.

Similar to how a conventional binding attaches to a board, the cam attaches to the binding with four bolts with the four-hole pattern. To re-engage the binding the user inserts the cam into the main cavity of the base. Along the side of the cam, grooves in the shape of a sine wave allow the binding to lock in place or release with the properly applied torque. When the user steps in and pushes the cam into the cavity, the followers are pushed back and snap back in to the grooves to keep the foot in place. With the boot and binding securely in place the setup should feel identical to one being securely fastened into a snowboard binding without our device. The cam also has recessed areas that hold magnets that assist the aligning for the re-engage process. They also help keep the foot securely in place when lined up properly.

Initial Prototype



Figure 15. Initial Rapid Prototyped Cam Fixed to the Bottom of a Binding



Figure 16. Initial Rapid Prototyped Baseplate with Springs, Followers, and Set Plates

Final Prototype

Our prototype V2.0 had a number of improvements from the first iteration. Releasing and re-engaging was vastly improved with a cam stopper notch that prevents overturning and locking into the next recess of the cam profile. The added notch allows the user to have more control by making it faster and easier to release. Releasing quickly and easily was a very important initial design goal to make doing aerial tricks a possibility.

Another design feature our team originally planned on including was the ability to adjust for snowboarders of all ages and sizes. Adding set screws allows the user to adjust the tension in the springs with a simple screwdriver; this makes releasing from the binding easier or harder, depending on the user's preference. For the final design, a single set screw is used to make it more robust and prevent shearing. Using a large single screw instead of two small screws makes adjustments both faster and easier. With two set screws, the user would have to adjust both screws perfectly equal to get the proper spring compression on both sides. One set screw displaces both springs evenly, resulting in less user error.

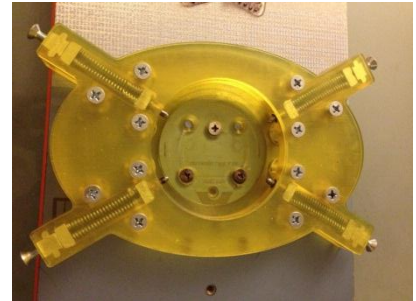

Figure 17. Final Rapid Prototyped Baseplate with Machined Spring Assembly.



Figure 18. Final Machined 3-Piece Cam System with Notch.

Safety Considerations

Since our design is based on allowing a rider to twist out, accidental or unwanted releases may take place. To lessen the frequency of unwanted releases we will implement an override lock that will prevent the twist out motion when the rider chooses to do so. When going very fast down groomed runs an auto release binding probably wouldn't be desirable. The rider will like the option of having it both conventional and auto release.

The other big safety concern is simply having it release when one wants it to release and doesn't release accidentally. The set screws on the design address this issue. The user would step in and out and then tighten the screws. This would be iterated until the user could no longer step in or twist out. Once this point was found the screws would be backed out a little to ensure that they could release and re-enter with the maximum torque for their capability.

ANALYSIS RESULTS

A quasi-static approach was used to determine the opposing torques on the cam profile due to the friction and normal forces. From our bench test, the desired torque was about 150 lb-in. The results of the analysis found a torque range from 107-199 lb_f-in. For a design with eight springs and a moderate amount of preload, this corresponded to a spring constant of about 20 lb_f/in. The final results are below in Table 3, and more detailed supporting analysis can be found in Appendix B.

Table 3. Final inputs to calculate torque range of 107-199 lb-in.

Description	Variable	Value	Units
Spring Constant	k	20	lb _f /in
Total Number of Springs	N	8	-
Minimum Preload	x ₁	0.1	inches
Screw Preload	x ₂	0.4	inches
Total Preload	x _T	0.5	inches

Finite Elements Analysis

The software program Abaqus was used to perform finite element analysis on the cam. The final meshed cam used 374,805 degrees of freedom with C3D10M elements. A static load of 150 lb_f was applied to replicate the force of stepping into the baseplate. Figure 16 displays the area where the force is distributed on the cam. This resulted in a pressure of 7.80 lb_f/in². The encastre boundary condition was applied to the top of cam to represent the cam connected to the rest of binding and rider.

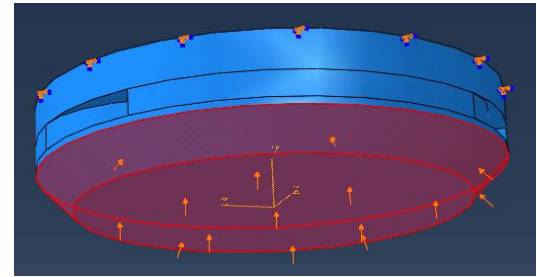

Figure 19. Applied Pressure on Bottom of Cam.

The highest stresses are located in the cam profile like expected. The locations of the two stress concentrations on the cam profile can be found below in Figure 17. This is where the major concern is for the cam to make sure it does not yield. Values for the von mises stresses on the cam as well as the yield stress for aluminum can be found below in Table 4.

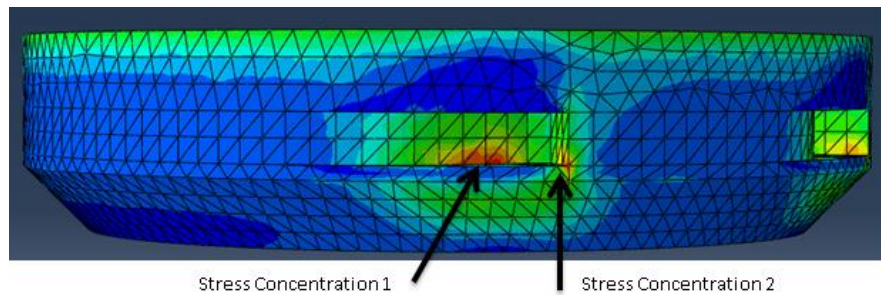

Figure 20. Location of Stress Concentrations on a Cam Profile.

Table 4. Comparison of von Mises stresses at stress concentrations to aluminum yield stress.

Stress Concentration 1 (psi)	23.00
Stress Concentration 2 (psi)	20.91
Al. Yield Stress (psi)	40E3

The stress concentrations are well below the yield points on aluminum. Therefore, having the entire cam be made from aluminum is not necessary. Like stated in our final design description, the top and bottom of the cam will be made from plastic. The middle section, which contains the cam profile, will be constructed from aluminum because it is a higher stress section.

Of course, this is a simplified static load case of the cam which neglects many critical components such as the followers. Future finite elements models are needed to more accurately predict the stresses on the cam. Actual testing is the only way to know if the final product is safe, but it is also difficult, time consuming, and expensive. The finite element model provided adequate information to confirm the final design of the cam.

COST ANALYSIS

Table 5. Price breakdown of Unbound Binding components.

Parts	Process	Part #	Dimension	Per Pack	Order Quantity	Price	Total Cost
Base Plate Bot.	RP	1	9"x6"x0.9"			\$250	\$250
Base Plate Top	RP	2	9"x6"x0.2"			\$81	\$81
Cam Middle	CNC	3	4"x0.3"		1	\$90	\$90
Cam Top	Lathe/Mill	4	4"x0.3"		1	\$35	\$35
Cam Bottom	Lathe/Mill	5	4"x0.4"		1	\$35	\$35
Follower	Mill/Press fit	6	0.3"x0.4"x0.6"				
Spring Alligner	Mill/Press fit	7	0.3"x0.4"x0.6"				
Set Screw Insert	Mill	8	0.75"x0.5"x0.625"				
Springs	Order	9657K231	2'xOD:1/4"xID:0.041"	6	2	\$9.21	\$18.42
Threaded T insert	Order	93766A200	3/4"x5/16" Thread 1/4" -20	50	1	\$8.50	\$8.50
Short low head screw	Order	90273A539	1/4"x5/8" 1/4 - 20	100	1	\$7.71	\$7.71
Bushing	Order	8491A768	OD:5/16 ID: 0.1935	1	4	\$6.82	\$27.28
TOTAL							\$553

Table 6. Raw Material and Tools.

Parts	Process	Part #	Dimension	Per Pack	Order Quantity	Price	Total Cost
Alum. Bar	Order	8975K37	1/2"x3/4"x6'	1	1	\$40	\$40
Alum. Rod	Order	88645K41	3', D=0.191	1	1	\$3.24	\$3.24
TICN Endmill	Order	8949A17	3/16"	1	1	\$19	\$19
TICN Endmill	Order	8949A14	1/8"	1	2	\$12	\$24
Corner Endmill	Order	8949A11	1/16"	1	1	\$32	\$32
Corner Endmill	Order	3067A12	3/32"	1	1	\$34	\$34
TOTAL							\$152

MANUFACTURING

We employed a number of different manufacturing processes to complete our prototype V2.0. The main housing of the binding was rapid prototyped out of a solid clear plastic that is much stronger than our first design and is nice for viewing purposes as people can see the inner workings of the mechanism. The metal inserts were then milled out of a rectangular aluminum bar to fit into the pockets and then were press fit with stock aluminum rods. This was done for both the followers and the spring aligners. The bigger follower aluminum rod on the follower was then ground down and rounded on a belt sander to allow for easy engaging and minimal friction with the cam system.

The custom milled set screw inserts were a bit harder to machine. Our design specified rounded edges because we initially planned to have housing constructed using a CNC machine. If we had machined the base on the CNC, sharp corner pockets would have been impossible, so we designed them to be round and the inserts and followers matched this design. To get the round edges, a special rounding end mill was ordered to take the corners off. In the end prototype, V2.0 looks very sharp as the rounded corners on the inserts nicely complement the round and elliptical shape of the base plate. Small details like this help make a consumer product more thought out and look cohesive opposed to having random individual pieces thrown together. This is something we were going for as our final product would be sold to consumers and ultimately needs to be both functional and aesthetically pleasing. To further improve appearance, the entire base plate and covering plate was dyed with chartreuse colored RIT dye.

The cam also required several machining steps as we moved away from the one piece cam from the original design. Since we wanted the cam profile to be machined out of metal and it called for an unconventional profile we had to have the middle piece CNC'd by the machine shop on campus, Mustang 60.



Figure 21. Final rapid prototyped baseplate with spring assembly.



Figure 22. Final machined spring assembly with milled edges, press-fit aligners, and sanded follower tip.

The top and bottom of the cam were made of delrin. They were both turned and faced to size using a lathe. The bottom piece had to be chamfered to displace the followers, then drilled and counter sunk to make room for the T-nuts. We then free handed the overturn slots with a dremel. Machining the cam and inserts taught us invaluable information about manufacturing and has given us great insight to future engineering design with the machinist and manufacturing in mind. Taking careful consideration of this can greatly cut down on the cost and time of making parts.



Figure 23. 3-piece machined cam attached to the bottom of a binding.

Future Manufacturing Plans

A lot of time and money were put into making prototype V2.0 since most of the parts were one offs and not off the shelf components. Hand machining would not be the greatest option for manufacturing a consumer product. The parts would be outsourced to a company which would either mass machine lots of parts at once or potentially cast or injection mold them. Before making a final decision, we would need to weigh all of the costs and benefits of these options to see which would be the best option for making our design. The plastic parts would be injection molded just as most binding components are currently made today. For our prototype this wasn't really a viable option as it would have taken longer and cost more compared to our rapid prototyped parts.

DESIGN VERIFICATION PLAN (TESTING)

Testing Plan

The prototype can be tested using a pair of snowboard boots and bindings. The base of our prototype would be bolted down to a stationary board and the cam is bolted to the binding. To test the apparatus the user steps into the binding with the cam attached onto its base. The user then steps into the base plate with the boot, binding, and cam securely fastened to their foot. This would be the reengagement portion of our test. This portion of the test is just as important as the auto re-release because the rider needs to be able to land securely when executing one footed or no footed airs.

The next portion of our test is the twisting motion which is the hands free auto-release motion. To twist out the user twists the rear foot inward with the binding attached to the cam in a counter-clockwise direction if the rider is regular footed (opposite if goofy) and then lifts their foot out once the followers are pushed out and no longer locked in by the cam.

The third test we would like to test, which isn't a primary concern but something we would hope works, is the upside down release. This would mimic a rider stuck in a tree well upside down. This should be a simple test to try as we would just need to lay on our back with the bottom of the board facing the sky and then attempt a release.

The next test is pre-load adjustment. This would consist of adjusting the apparatus' set screws to make it easier or harder to release and re-engage. We would start with them backed all the way out to ensure the rider could release and re-engage. We would then tighten them a little and repeat the process until we got to a point where the rider could no longer step in or step out. This would be the threshold. With this point we could figure out the max load and figure out a solid number for the rider to use. Eventually if enough riders were tested we could get an idea of what settings work for who based on skill, weight, and height and have the adjustments done without the need of this iterative process for each rider much in the same way skiers have their DIN setting. The pre-load in the springs is directly correlated to the displacement in the springs which can also be used to calculate the torque.

Once all the preliminary tests are completed, the final test would be a ride test down the mountain. While on the slopes we would hope to first test disengaging and re-engaging while a rider is in motion going down an actual run. Once this is proved capable we would hope to test it for one footed or no footed aerial tricks.

Actual Testing

Although our testing was minimal since we didn't get a chance to take the prototype to the mountain we were able to pull some important numbers and facts from our brief testing. The main thing we learned was that the locking mechanism was a lot harder to get

in and out than expected. Adding a little bit of preload to the springs went a long way. With no preload it was very easy to compress the springs and push the followers in with your hand alone. Though we then tightened the set screws one turn at a time and continued pushing the follower in and out after each turn. After only 6 turns or roughly a half inch of displacement it was nearly impossible to push the followers in with just your fingers.

We would have liked to do this same routine with both stepping into the mechanism and then releasing but ran into problems as our slider bearings started slipping in the slots, displacing the springs more than we wanted. The other issue that arose was our cam profile got way more chewed up than expected and we believe started giving unwanted friction between the follower and the cam as it dug fairly deep grooves in the plastic. The other interesting problem we realized is how much better the toe followers clipped into the cam compared to the heel followers. When we tried quickly stomping in the toe followers would actually engage while the heel followers wouldn't engage. This was apparent when comparing the wear on the front of the cam and the back. The front had little to no wear whereas the back looked like a dogs chew toy.

CONCLUSIONS AND RECOMMENDATIONS

Though prototype V2.0 had some changes and improvements to the first prototype, many improvements still need to be made to make it marketable and truly ride able. The first step is to test it on the mountain in a snowy environment and see how it performs and holds up. Since the final prototype wasn't completed until spring, actual field testing was out of the question. Our preliminary test of actuating the system and disengaging yielded promising results and the prototype performed how we expected it to.

For V2.0, we made improvements to the cam by adding the overturn mechanism and slotted bottom to make it easier to slide out. Sandwiching a piece of aluminum between two pieces of delrin added strength to the cam profile and prevented wear from the followers. The aluminum saw very little wear compared to the original rapid prototyped cam, but the delrin unfortunately saw similar gouging and wear like the rapid prototyped plastic saw. The whole cam profile would need to be machined out of aluminum to hold up to the average wear and tear a snowboarder would put on it. Another change is better machining of the followers. Our final design consisted of hand sanded followers. Using a CNC, machining a more rounded follower end could help reduce the wear on the cam.

When talking to snowboarders about our design we received feedback with concerns that our design would change the ride too much. To address this we would need to figure out ways to make the system more compact so that we could lower the profile of the system, bringing the rider closer to the board.

The prototype is still a little bulky, and future designs would need to focus on a slimmer final product. Prototype V2.0 looks very similar to V1.0 because the first prototype worked well. We were more concerned with adding improvements compared to overhauling the design. Future designs would focus on integrating the cam profile onto a binding itself. Integration reduces the overall height of the cam that will stick out of the binding. We would also want to make the main housing out of aluminum and then heavily pocket the design. This would keep the structural integrity of the device and it could be manufactured with a CNC machine or cast.

The next improvement would be slimming down the binding itself. Most current bindings are affixed with two robust ratchet locking mechanisms designed to repeatedly lock and release the boot in place. We could potentially move towards a light steel braided cable that is woven like a spider web to keep the rider in. The rider would have a harder time attaching the binding to the boot, but the idea is that the user could simply twist out with our mechanism on the chair lift and would only have to worry about getting out of the binding a few times a day. With our binding, transferring to and from the chair lift is much easier, and snowboarders won't have to waste time sitting in the snow strapping in.

Instead, a simple stomp of the foot is all that is needed to begin their ride down the mountain.

Economics and Marketing

All snowboard and ski equipment has a high price tag, but most consumers don't pay full retail price. Many tend to wait for sales later in the season or when the price drops in spring to buy their equipment. The manufacturers know this and are only interested in profit margins. They also know that consumers have a maximum price tag that they will spend for a boots, bindings, and board setup. They have approximated this number at around \$500. Most of this money will be spent on the board and the boots, so the consumer spends considerably less money on the bindings. Because of this, companies don't want to invest much research and development into new binding technology. In addition many companies are stuck to the mentality of "if it isn't broken, why fix it?" They also don't want the liability that comes with selling non-releasable bindings if a releasable binding exists. They have escaped lawsuits of selling unsafe bindings because an alternative doesn't exist.

This is where our idea and potential company will come in. With a viable idea with and a working prototype, we could potentially make current snowboard bindings look archaic and obsolete. If they are truly proven to be safer, ski resorts will enforce riders only using the new bindings as they did with auto-release ski bindings.

Additionally, the trend across all extreme sports is new technology that allows the user to progress the sport with new tricks. This is what engages the professionals initially. Amateurs see the professionals doing these new maneuvers and feel an urge to buy the newest equipment to mimic them. We need to have professional snowboarders take up the challenge of learning to use our binding and performing with them in tournaments for exposure to their fans.

The market is also growing. There are over six million snowboarders and these numbers are increasing. This gives us six million potential customers. If we were to sell our product at \$150, our potential revenue would be \$900,000,000. Obviously this is unreasonable to assume that we would sell to every snowboarder, but we definitely have a large consumer base.

REFERENCES

Bhalla, Rohit S., Christopher Doody, Richard McGuinness, and Sean K. O'Dowd. *Design of a Releasable Snowboard Binding System to Prevent Upper Body Injury*. [Http://www.wpi.edu](http://www.wpi.edu). WORCESTER POLYTECHNIC INSTITUTE, 30 Apr. 2007. Web. 16 Oct. 2011.

Flip U. Advertisement. *Sports180 - Makers of the Flip-U Snowboard Binding Rotation Device*. Sports180, Inc., 2003. Web. 20 Oct. 2011.

K-2 Corporation. "Bindings | K2 Snowboarding 2011-12." *K2 Snowboarding 2011-12 / Snowboards, Boots, Bindings*. K2 Snowboarding, 2011. Web. 23 Oct. 2011.

Nowtash, Ashkan, Nunez, Anthony, Hill, Patrick, and Welker, Maxwell. *Design of a Snowboard Design*. [Http://www.wpi.edu](http://www.wpi.edu). WORCESTER POLYTECHNIC INSTITUTE, 30 Apr. 2009. Web. 16 Oct. 2011.

"Ride Nitrane Bindings - YouTube." *YouTube - Broadcast Yourself*. BLUE TOMATO, 10 Sept. 2009. Web. 23 Oct. 2011. <http://www.youtube.com/watch?v=_LnniZNJ4q0>.

The Angry Snowboarder. "Twist These Bindings." Web log post. *The Angry Snowboarder*. 7 Sept. 2011. Web. 20 Oct. 2011.

Ulrich, Karl T., and Steven D. Eppinger. *Product Design and Development*. Boston: Irwin/McGraw-Hill, 2000. Print.

Will. "Avy and Tree Well Release for Snowboard Bindings - YouTube." *YouTube - Broadcast Yourself*. Splitboard, 7 Feb. 2008. Web. 22 Oct. 2011. <<http://www.youtube.com/watch?v=5Gyg9zNb0vU>>.

ASTM testing site reference:
http://enterprise.astm.org/filtrexx40.cgi?+REDLINE_PAGES/F2546.htm

Determination of Spring Constant

The main component in the design is the spring. In order to know the spring needed, and the subsequent design to fit these springs, analysis must be used to estimate a spring constant.

Twist-Out Motion

First, a bench test is used to get an idea of how much torque a human could apply at the foot using a twisting motion. The maximum torque applied varied from 200 to 350 lb-in. From the analysis, a spring constant needs to be found that will apply about 50% of this maximum torque.

The only forces that will provide torque to oppose motion are the normal force, F_N , and the friction force, F_f , created by the spring force. With these forces, the total opposing torque can be found by multiplying the sum by the moment arm.

$$T = (F_f + F_N) \times \text{Moment Arm} \quad (\text{Eq. 1})$$

The following assumptions were made for the system:

- coefficient of friction, $\mu=0.5$
- geometric preload (min. preload)=0.1 in.
- screw preload=0.5 in.
- total number of springs=8
- Total rotation angle, $\theta=30$ degrees
- change in length of cam profile=0.3 in.

For the cam profile, a steep initial angle a horizontal final angle was previously chosen during the design phase. To replicate this, the cam profile is made using a sine function.

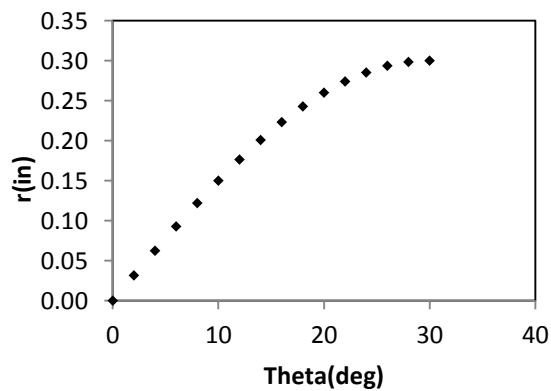

Figure B1. Profile for cam follower using a sine function.

The spring constant was adjusted in the excel file until the estimated range of torques can be found.

Appendix B

Table B1. Final inputs for excel spreadsheet torque calculation.

Inputs		
k	k	20
total # of springs	n	8
min. preload	x_1	0.1
screw preload	x_2	0.4
total preload	x_T	0.5

Table B2. Calculated opposing torques on cam plate.

theta(deg)	r(in)	Moment Arm	T_f	T_N	T_T (lb-in)
0	0.00	1.20	50	58	107
2	0.03	1.23	54	62	116
4	0.06	1.26	58	67	125
6	0.09	1.29	62	72	134
8	0.12	1.32	66	76	142
10	0.15	1.35	70	81	151
12	0.18	1.38	74	85	160
14	0.20	1.40	78	90	167
16	0.22	1.42	81	94	175
18	0.24	1.44	84	97	181
20	0.26	1.46	87	100	187
22	0.27	1.47	89	103	192
24	0.29	1.49	91	105	196
26	0.29	1.49	92	107	199
28	0.30	1.50	108	0	108
30	0.30	1.50	108	0	108

From the analytical results found in Table 2 above, the total opposing torque, T_T , is 107-199 lb-in, which is in the initial desired range of torques. The results for the twisting-out motion estimate a spring constant, k , of around 20 lb/in.

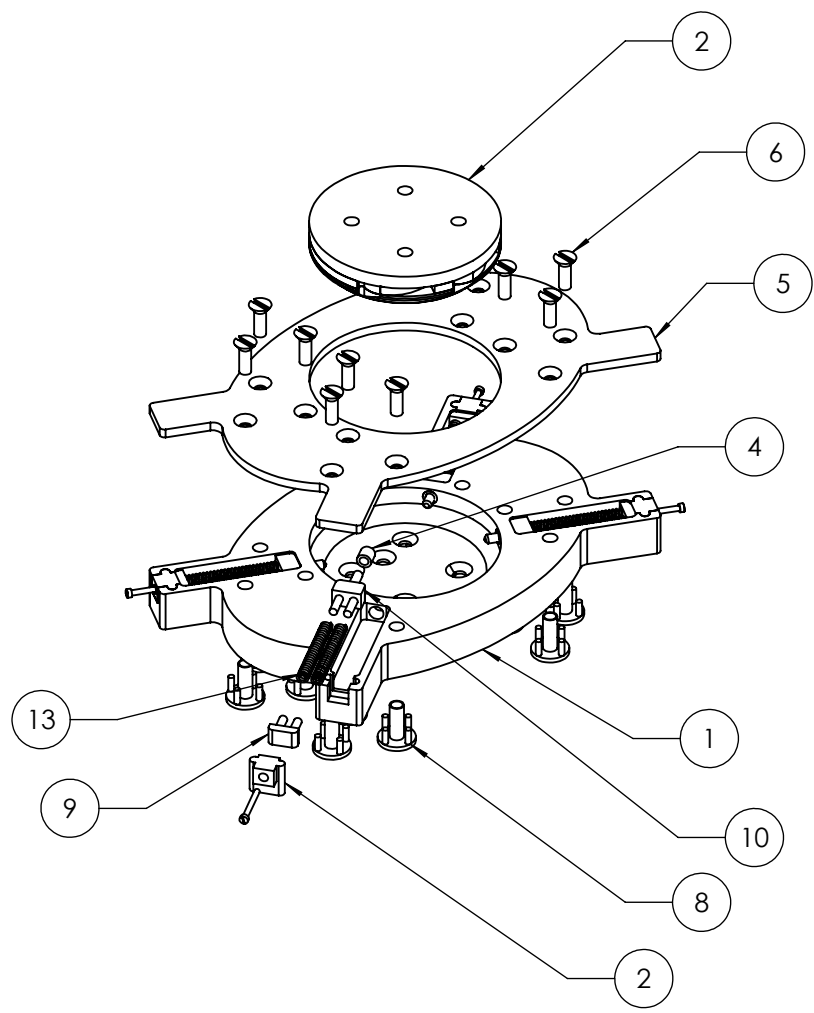

ITEM NO.	PART NUMBER	QTY.
1	Snowboard Base	1
2	Cam Assembly	1
2	Outer Insert	4
4	Bushing	4
5	Top Plate	1
6	Screw	16
8	Nut	12
9	Inner plate	4
10	Follower	4
13	Spring	8

Senior Project



DATE: 6/1/2012	UNITS: INCHES	
TOLERANCE:	SCALE: 1 : 4	TITLE: EXPLODED VIEW
LEC SEC:	NEXT ASSY:	
LAB SEC:	DRAWING #:	

ITEM NO.	DESCRIPTION	QTY.
1	CAM BOTTOM	1
2	CAM MIDDLE	1
3	CAM TOP	1

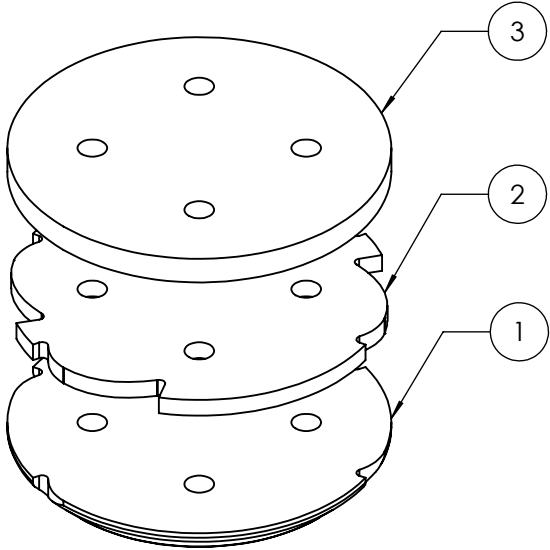

Senior Project



DATE: 6/4/2012

UNITS: INCHES

TOLERANCE:

SCALE: 1 : 2

TITLE: CAM

LEC SEC:

NEXT ASSY:

LAB SEC:

DRAWING #:

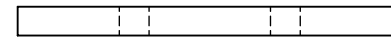
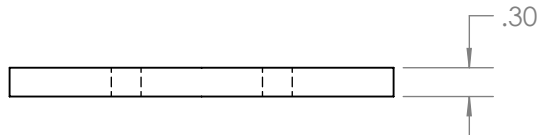
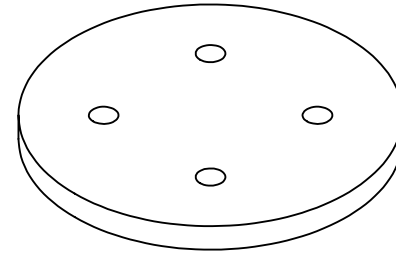
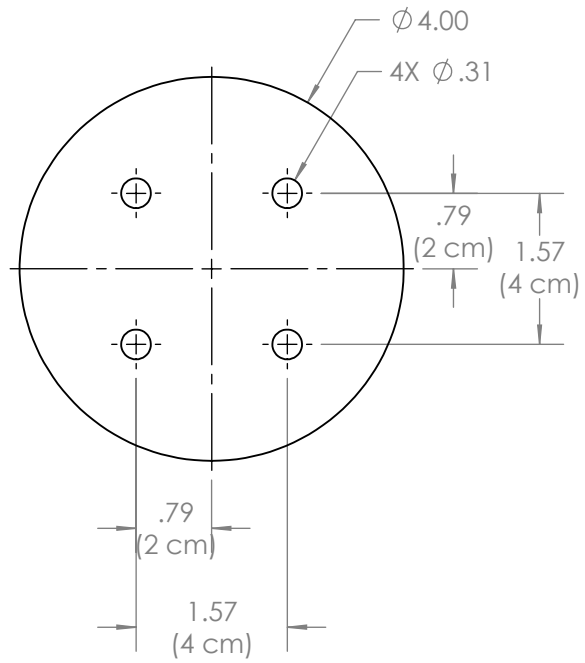

Senior Project

unBOUND 

DATE: 6/1/2012

UNITS: INCHES

MATERIAL: DELRIN

TOLERANCE:

SCALE: 1 : 2

TITLE: CAM - TOP

LEC SEC:

NEXT ASSY:

LAB SEC:

DRAWING #:

5

4

3

2

1

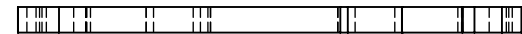
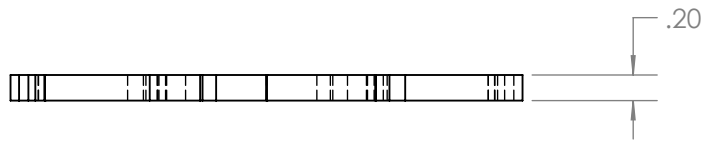
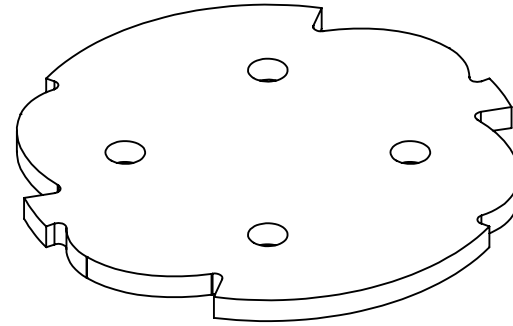
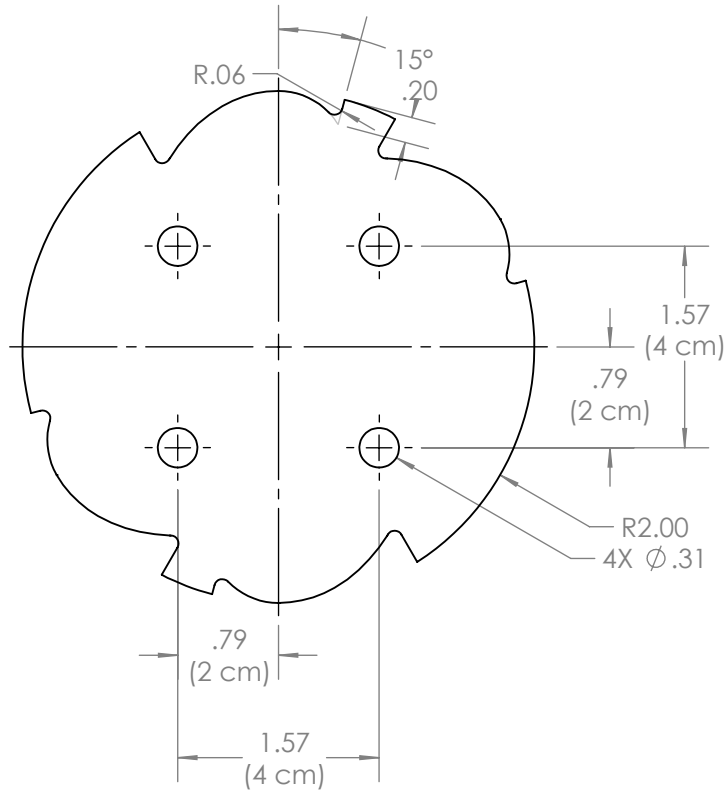

Senior Project



DATE: 6/1/2012

UNITS: INCHES

MATERIAL: ALUMINUM

TOLERANCE:

SCALE: 2 : 3

TITLE: CAM - MIDDLE

LEC SEC:

NEXT ASSY:

LAB SEC:

DRAWING #:

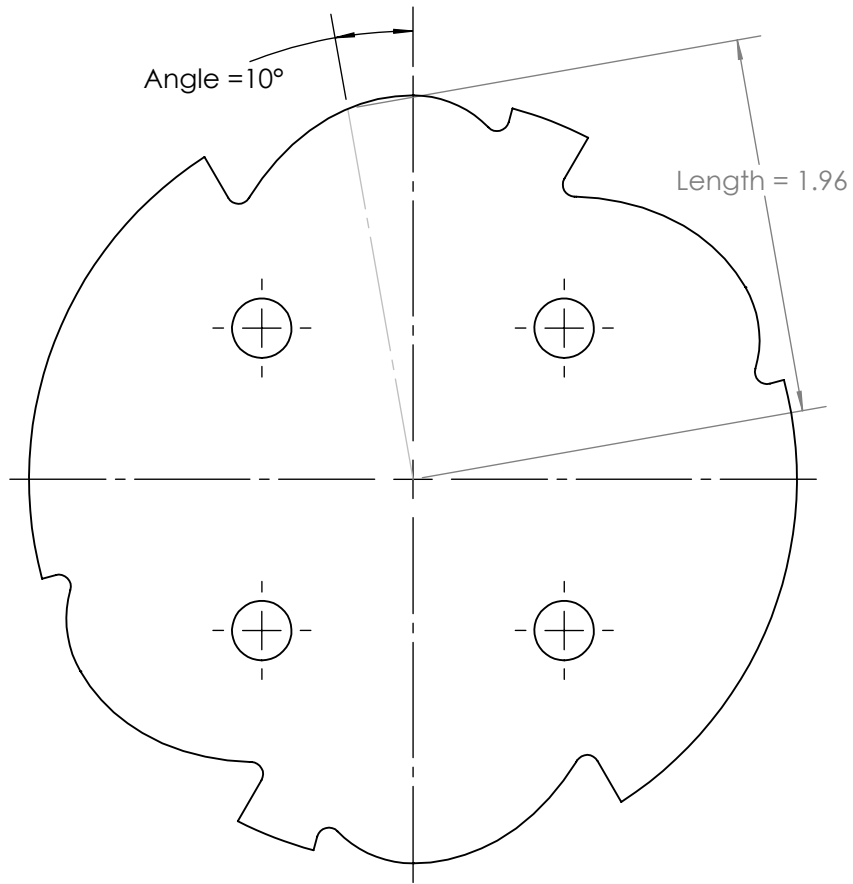

Angle	Length
0	2.00
2	1.99
4	1.99
6	1.98
8	1.97
10	1.96
12	1.94
14	1.92
16	1.90
18	1.88
20	1.85
22	1.82
24	1.79
26	1.76
28	1.73
30	1.70

Senior Project



DATE: 6/1/2012

UNITS: INCHES

MATERIAL: ALUMINUM

TOLERANCE:

SCALE: 1 : 1

TITLE: CAM - MIDDLE - SPLINE PROFILE

LEC SEC:

NEXT ASSY:

LAB SEC:

DRAWING #:

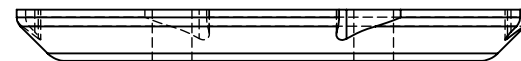
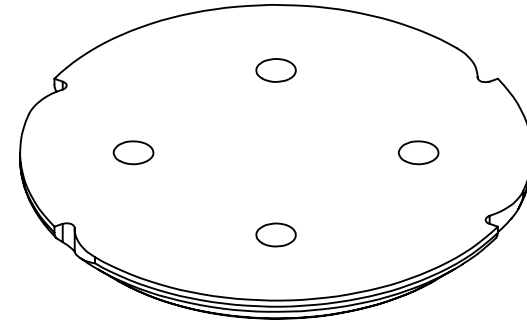
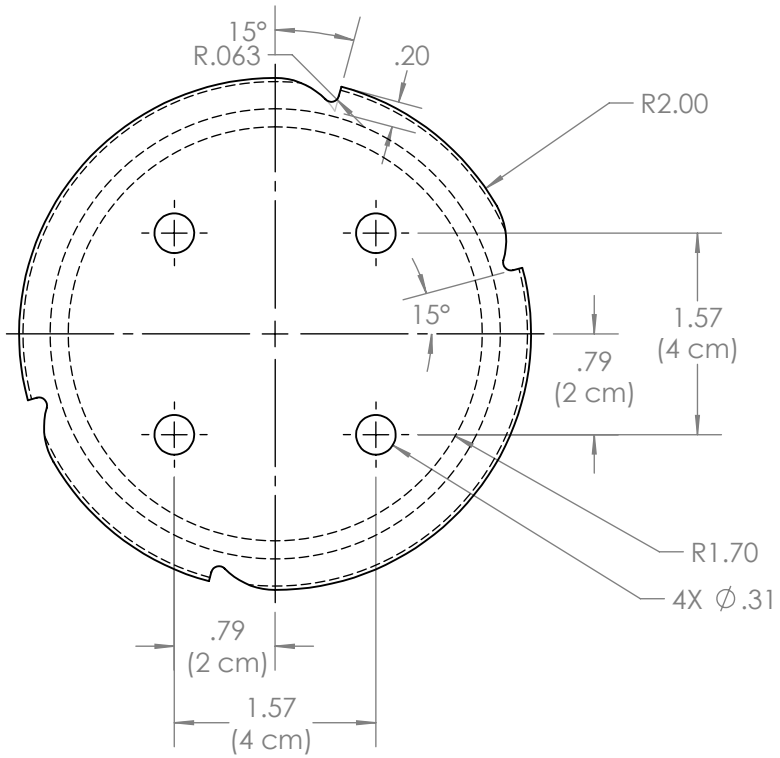

Senior Project



DATE: 6/1/2012

UNITS: INCHES

MATERIAL: DELRIN

TOLERANCE:

SCALE: 2 : 3

TITLE: CAM - BOTTOM

LEC SEC:

NEXT ASSY:

LAB SEC:

DRAWING #:

5

4

3

2

1

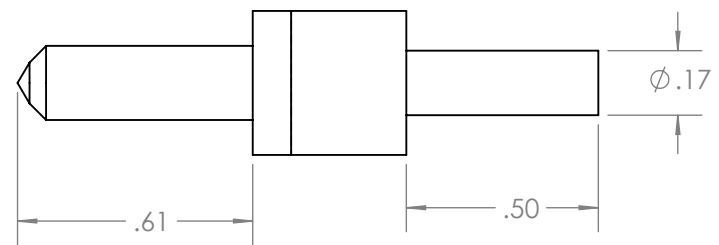
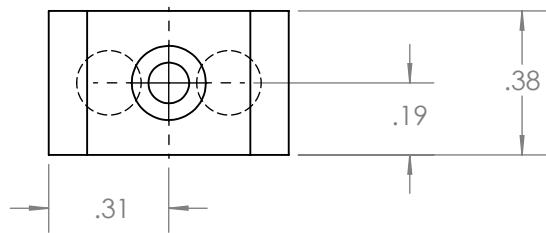
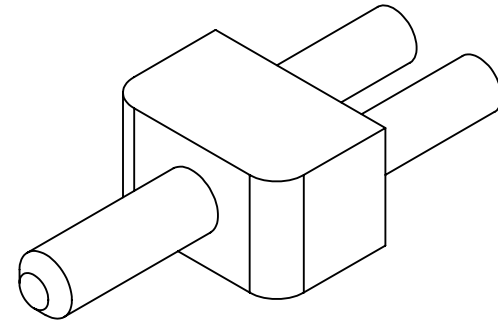
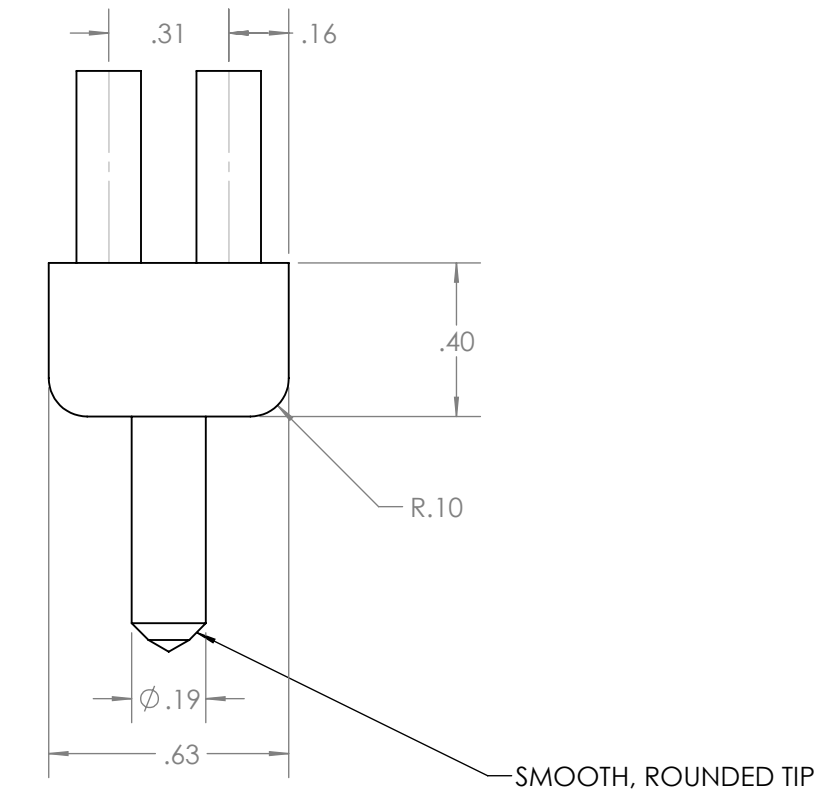

COLUMNS ARE PRESS FIT INTO
0.16" DIAMETER HOLES 0.15" DEEP

Senior Project



DATE: 6/1/2012

UNITS: INCHES

MATERIAL: ALUMINUM

TOLERANCE:

SCALE: 2 : 1

TITLE: FOLLOWER

LEC SEC:

NEXT ASSY:

LAB SEC:

DRAWING #:

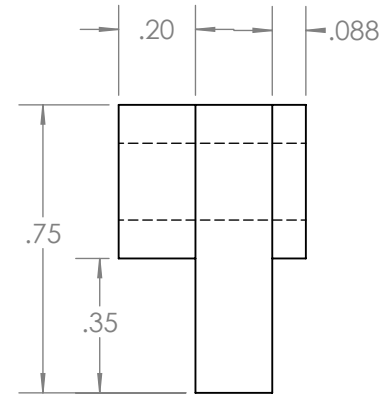
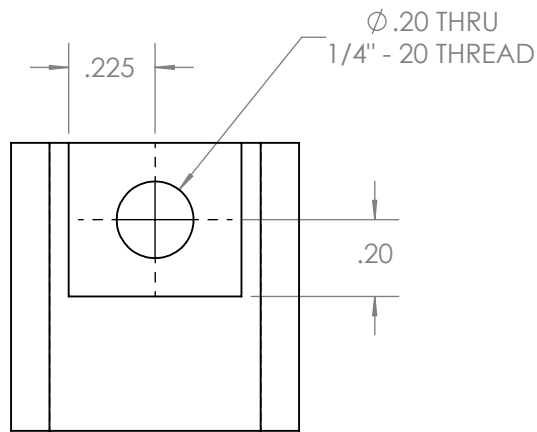
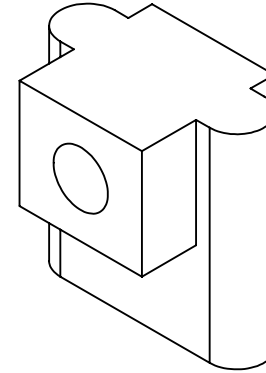
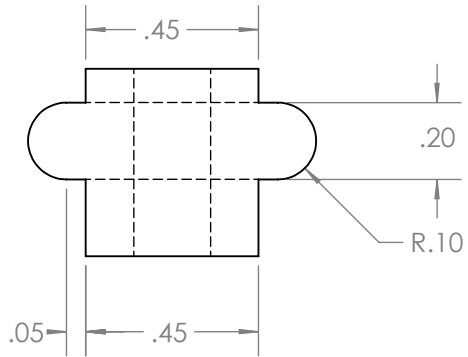

Senior Project



DATE: 6/1/2012

UNITS: INCHES

MATERIAL: ALUMINUM

TOLERANCE:

SCALE: 2 : 1

TITLE: OUTER INSERT

LEC SEC:

NEXT ASSY:

LAB SEC:

DRAWING #:

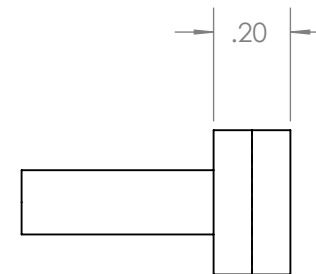
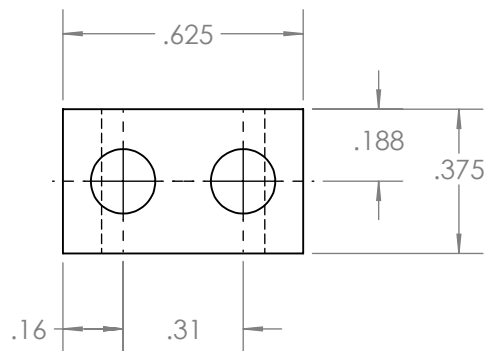
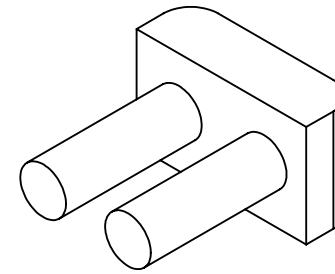
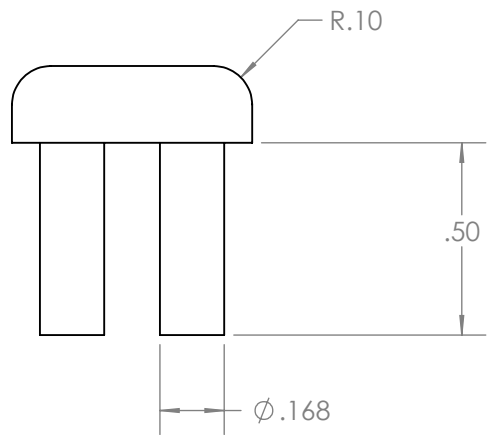

COLUMNS ARE PRESS FIT INTO
0.16" DIAMETER HOLES 0.15" DEEP

Senior Project



DATE: 6/1/2012

UNITS: INCHES

MATERIAL: ALUMINUM

TOLERANCE:

SCALE: 2 : 1

TITLE: BACK PLATE

LEC SEC:

NEXT ASSY:

LAB SEC:

DRAWING #:

5

4

3

2

1

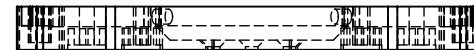
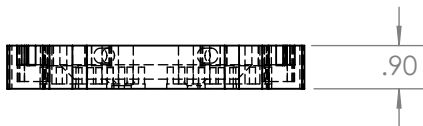
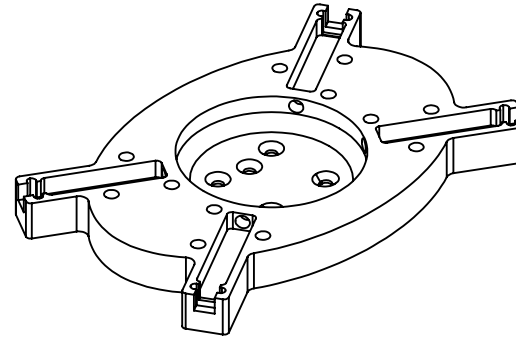
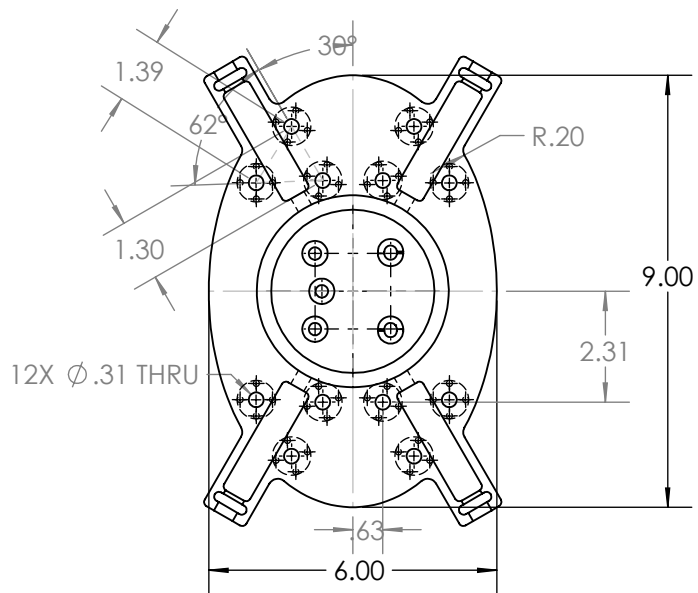

Senior Project



DATE: 6/1/2012

UNITS: INCHES

MATERIAL: ALUMINUM

TOLERANCE:

SCALE: 1 : 4

TITLE: BASE PLATE

LEC SEC:

NEXT ASSY:

LAB SEC:

DRAWING #:

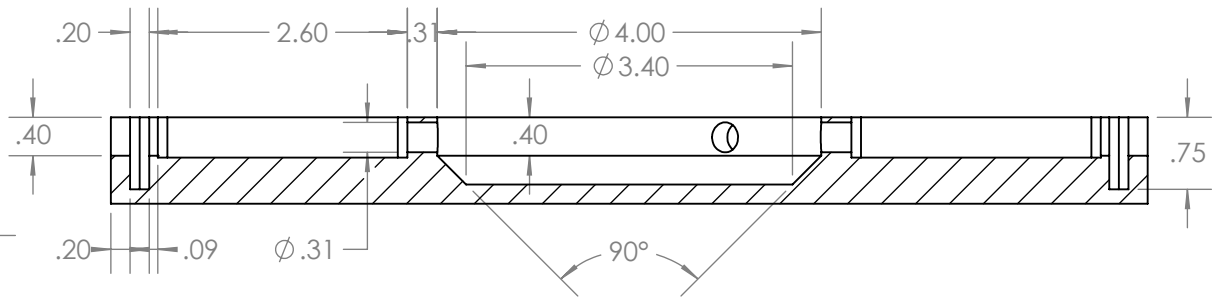
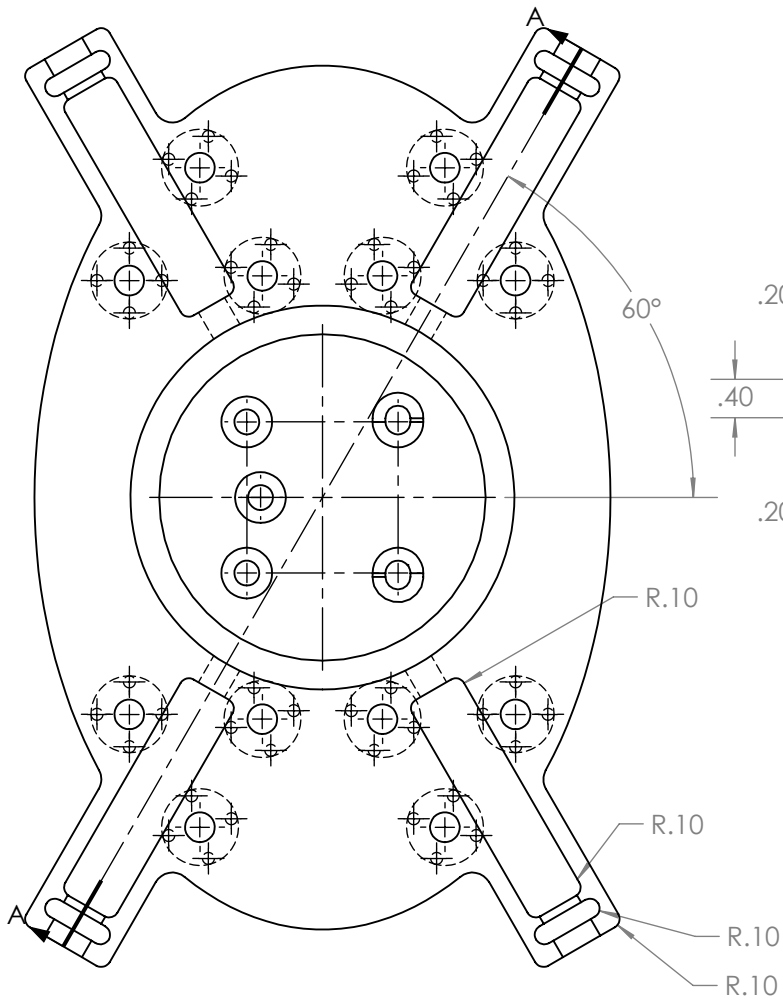

Senior Project



DATE: 6/1/2012

UNITS: INCHES

MATERIAL: ALUMINUM

TOLERANCE:

SCALE: 1 : 2

TITLE: BASE PLATE - SECTION

LEC SEC:

NEXT ASSY:

LAB SEC:

DRAWING #:

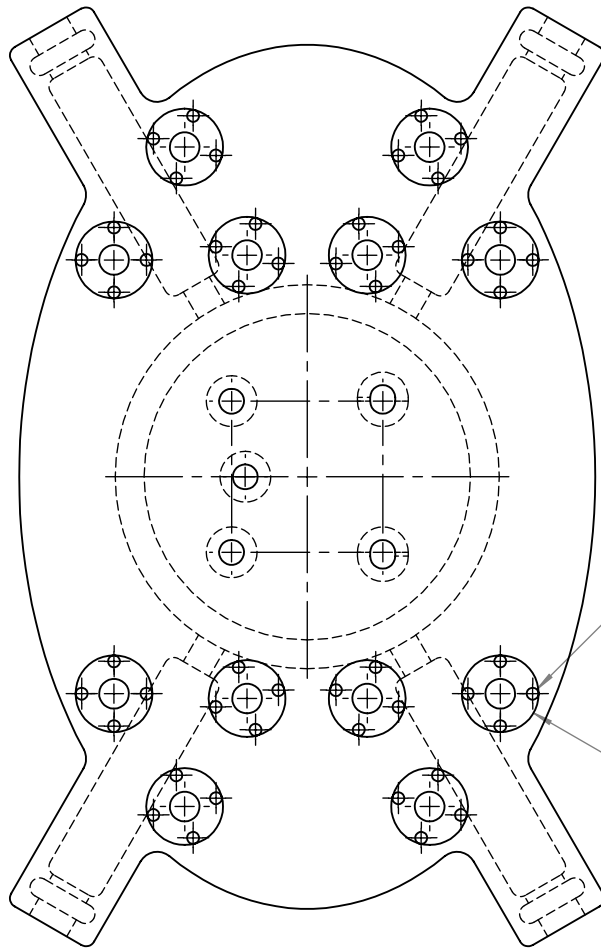

48X $\varnothing .13 \nabla .35$
TANGENT TO FACE
90° CIRCULAR PATTERN

12X $\varnothing .80 \nabla .10$

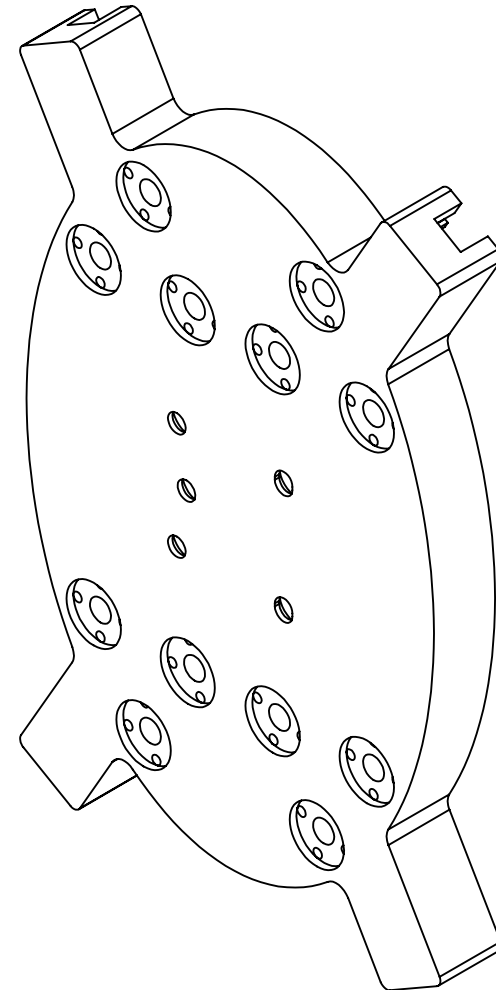

Senior Project

unBOUND 

DATE: 6/1/2012

UNITS: INCHES

MATERIAL: ALUMINUM

TOLERANCE:

SCALE: 1 : 2

TITLE: BASE PLATE - BOTTOM

LEC SEC:

NEXT ASSY:

LAB SEC:

DRAWING #:

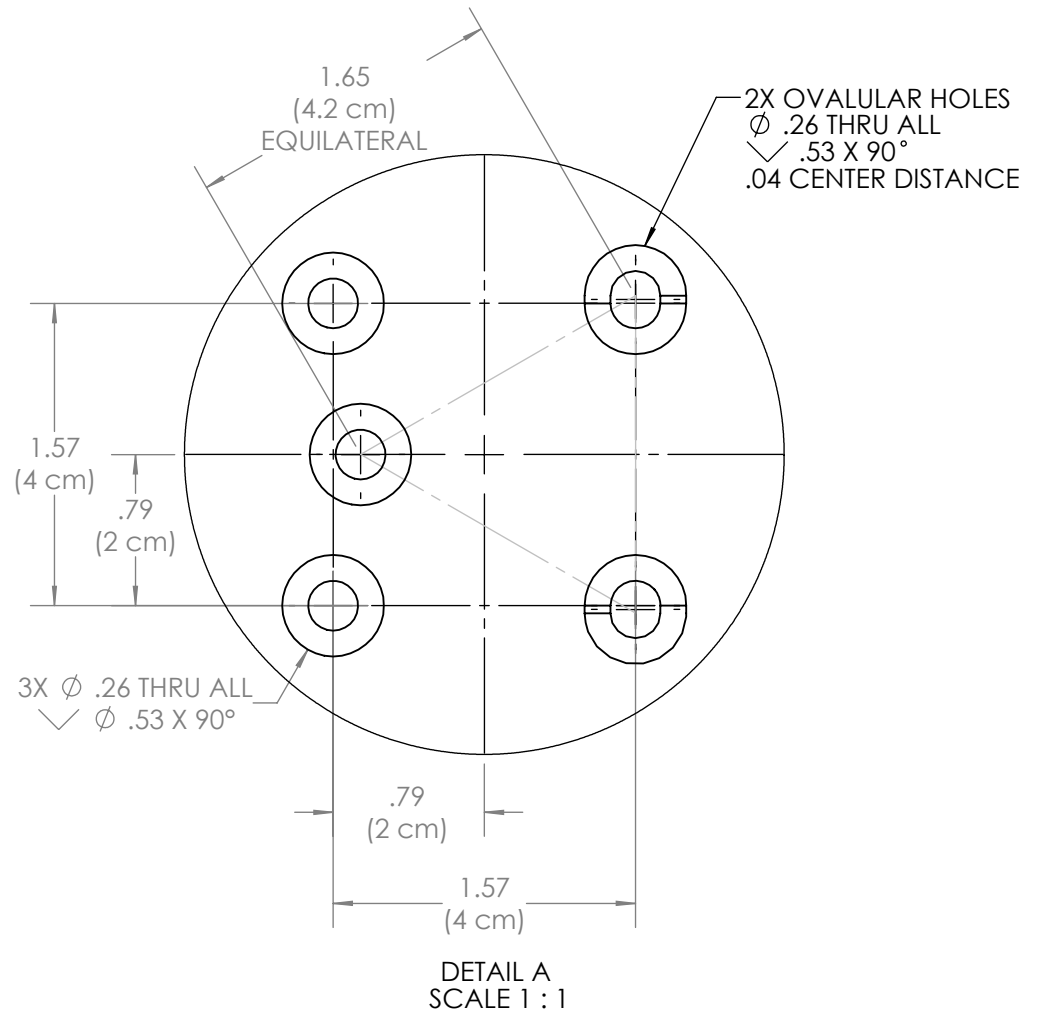
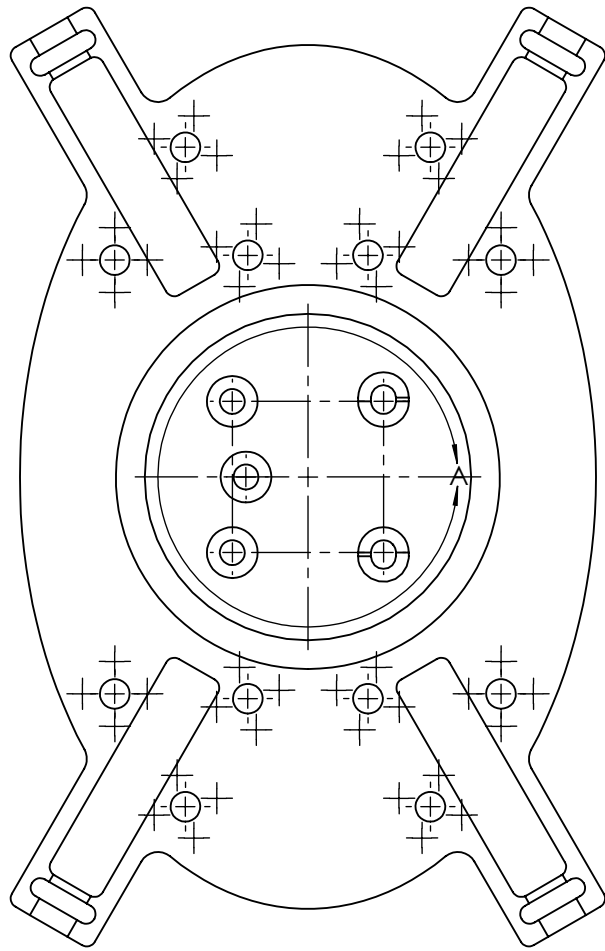

Senior Project



DATE: 6/1/2012

UNITS: INCHES

MATERIAL: ALUMINUM

TOLERANCE:

SCALE: 1 : 2

TITLE: BASE PLATE - HOLE PATTERN

LEC SEC:

NEXT ASSY:

LAB SEC:

DRAWING #:

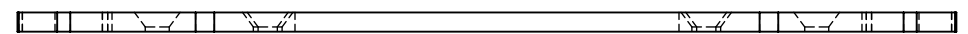
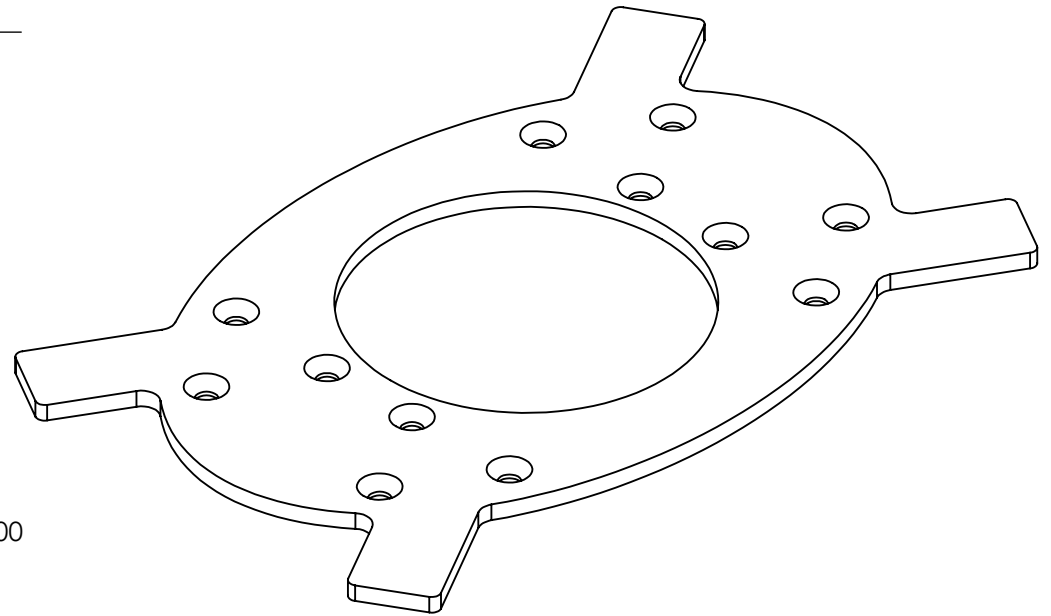
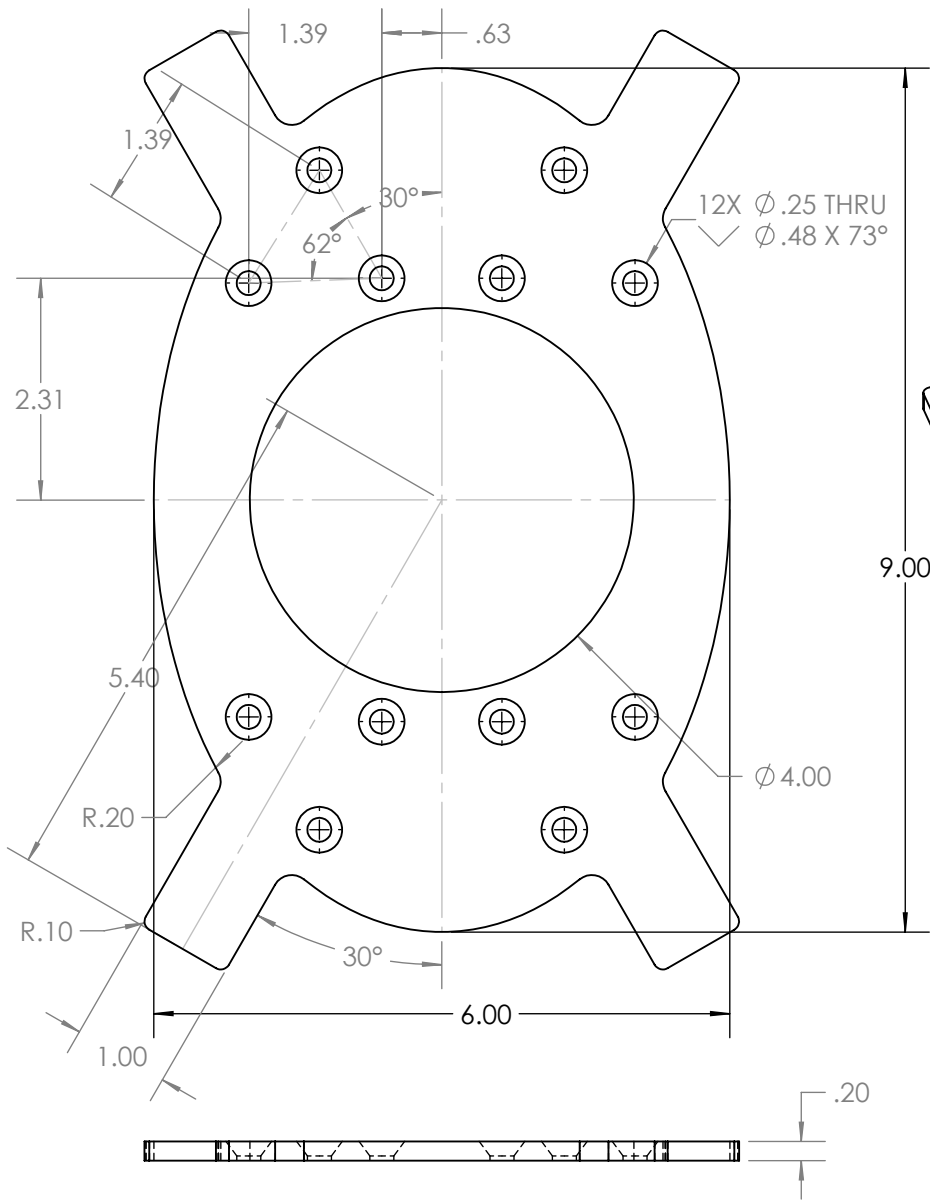

Senior Project



DATE: 6/1/2012

UNITS: INCHES

MATERIAL: ALUMINUM

TOLERANCE:

SCALE: 1 : 2

TITLE: TOP PLATE

LEC SEC:

NEXT ASSY:

LAB SEC:

DRAWING #: