

Mini Pump

Final Project Report

Mechanical Engineering Department
California Polytechnic State University
San Luis Obispo
2012

Engineering Team:

Stephen Scruggs, sscruggs@calpoly.edu
Britta Berg-Johansen, bbergjoh@calpoly.edu
Kyle Kriete, kkriete@calpoly.edu

Advisor:

Dr. Joseph Mello, jdmello@calpoly.edu



Statement of Disclaimer

Since this project is a result of a class assignment, it has been graded and accepted as fulfillment of the course requirements. Acceptance does not imply technical accuracy or reliability. Any use of information in this report is done at the risk of the user. These risks may include catastrophic failure of the device or infringement of patent or copyright laws. California Polytechnic State University at San Luis Obispo and its staff cannot be held liable for any use or misuse of the project.

Table of Contents:

List of Figures and Tables	iii
Abstract	1
Introduction	2
Background	3
Existing Products	3
Market Research	4
Related Patents	4
Materials Research	6
Design Requirement and Specifications	7
Design Development	8
Initial Design Sketches	8
Preliminary Concept Selection	9
Crank Concepts	9
Geared Power Screw Design	9
Connecting Rod Design	10
Wave Driven Design	11
Spring Variation of Wave Design	12
Initial Design Selection	13
Preliminary Testing	14
Crank Torque Test	14
Material Strength Test	15
Material Friction Test	16
Prototype #1: Testing and Observations	17
Final Design	18
Hardware	19
Final Prototype	21
Cost Estimation	23
Design Verification	26
Conclusions and Recommendations	27

Appendix A	A-1
Rapid Prototyping Comparison	A-1
Plastic Design Guidelines	A-2
Appendix B	B-1
QFD House of Quality	B-1
Appendix C	C-1
Patent Research	C-1
Excerpt from Patent No. 6,409,618 B1	-
Excerpt from Patent No. 2011/0038798 A1	-
Excerpt from Patent No. 5,214,462	-
Excerpt from Patent No. 5,467,684	-
Appendix D	D-1
Geared Power Screw Design Simulation	D-1
Appendix E	E-1
Connecting Rod Design Simulation	E-1
Appendix F	F-1
Wave Driven Design Analysis	F-1
Appendix G	G-1
Development of Ideal Gas Pressure	G-1
Appendix H	H-1
MATLAB code for Wave Simulation	H-1
Appendix I	I-1
SIMULINK model for Wave Simulation	I-1
Appendix J	J-1
Output Plots from Wave Simulation	J-1
Appendix K	K-1
Output Plots from Spring Aided Design	K-1
Appendix L	L-1
Crank Test Calculations	L-1
Appendix M	M-1
Friction Test Calculations	M-1

Appendix N	N-1
Bending Calculations	N-1
Appendix O	O-1
X-ring Compression Calculations	O-1
Appendix P	P-1
Cost Estimation	P-1
Appendix Q	Q-1
Technical Drawings	Q-1

List of Figures and Tables:

Figure 1	Nike Sport Ball Pump	2
Figure 2	Bike Pump	2
Figure 3	Miniature Bike Pump	2
Figure 4	Squeeze Pump	2
Figure 5	Patent images (1)	4
Figure 6	Patent images (2)	4
Figure 7	Geared Mechanism Concept Sketch	8
Figure 8	Half Moon Gear Sketch	9
Figure 9	Connecting Rod Concept Sketch	9
Figure 10	Wave Driven Concept Sketch	10
Figure 11	Waveform Plot	11
Figure 12	Modified Waveform Plot	11
Figure 13	Wave Design Solid Model	12
Figure 14	Crank Test Apparatus	13
Figure 15	Material Testing Blank	14
Figure 16	Bend Test Apparatus	14
Figure 17	Friction Test Apparatus	15
Figure 18	Prototype #1 Images	16
Figure 19	Final Design Exploded View	17
Figure 20	X-ring Schematic	18

Figure 21	Umbrella Valve	18
Figure 22	Duckbill Valve	19
Figure 23	Final Prototype Images	20
Figure 24	Unit Cost vs. Production Size	23
Figure 25	Capital Cost vs. Production Size	23
Figure 26	Ball Inflation Pressures Relative to Mini Pump	25
Table 1	Properties of Thermoplastics	5
Table 2	Design Requirements for Mini Pump	6
Table 3	Summary of Initial Design Sketches	7
Table 4	Crank Test Data	13
Table 5	Crank Test Results	14
Table 6	Bend Test Data	14
Table 7	Cost Estimation Summary	23

Abstract

Ball pumps that are currently on the market are inconvenient due to their large size and lack of portability. Another shortcoming of existing pumps is the lack of storage space for the inflation needle, resulting in users often losing or misplacing the needle. Furthermore, the traditional push-pull pumping motion is not ergonomically ideal.

Given the limitations of existing pumps, we are redesigning and improving the traditional ball pump. The primary design objective of this project is to increase the portability and convenience of a ball pump while maintaining similar functionality. The pump will be small enough to fit on a keychain and clip to a backpack or sports bag. A secondary design objective of this pump is to provide a storage solution for the inflation needle. To meet these design goals, we have replaced the traditional push-pull pumping motion with a smooth cranking motion. Cranking is a more ergonomic and efficient user interface. The pump compensates for the reduced volume of the pump by increasing the flow rate with a more efficient pumping mechanism. Because cost is also a design consideration, the pump we have designed has a low part count and is easy to manufacture.

The following design report documents the development of the pump project. It begins by discussing the market research that was conducted to gauge market interest in this type of product. The market research section contains information about existing ball pumps and patents. From the market research, we developed design requirements for the project and then created multiple design concepts. Each of the top design concepts was analyzed for feasibility, and a design for the first prototype was selected. The initial design was developed with detailed analysis, and a solid model was created with associated technical drawings. The first prototype was built on an Eden rapid prototyping machine, and testing was performed on the prototype. Downfalls of the first prototype led to various design changes that were implemented for the second design. Similar analysis was performed for the second design, and a final prototype was built. Next, a cost analysis was completed on the final pump design. Testing was carried out on the final prototype. It successfully inflated volleyball in 15 to 20 seconds. The maximum operating pressure of the pump was determined to be approximately 6-7 psi. The report concludes with a recommendation for future projects. The appendices provide additional detail not included in the body of the report.

Introduction

The Mini Pump was a student proposed project with the objective of creating a new pump design for inflating sports balls. It was proposed to the Mechanical Engineering Department as an entrepreneurial senior project in which both the technical and business sides of the pump would be explored. Often times at the sport fields players find their balls have become deflated since the last time they played. Therefore there is a need for a highly portable and ergonomic method of inflating the equipment. The goal of the project was to create a pump that could compete commercially with the pumps that are currently on the market. The main objective was to decrease the size of currently available ball pumps.

Under the guidance of Dr. Joseph Mello this project began over the summer of 2011. After gaining approval for this project brainstorming began almost immediately. By the beginning of fall quarter several ideas had been considered and a first prototype was selected for analysis and testing. The majority of the designing occurred throughout fall quarter, leading into a build phase early in winter quarter. After testing the first prototype, it was decided to redesign certain aspects and build a second prototype for testing in spring of 2012. This second prototype was tested for the final product of this project.

Background

Several different types of ball pumps are currently available on the market. The main competing products are a traditional bike pump, a sport pump, a mini pump and a bulb pump (see Figures 1-4). These items all accomplish the same goal of inflating sports balls, yet each has its own drawbacks. The majority of current pumps on the market cost between \$5.00 and \$15.00, with the more expensive end of the spectrum being pumps with recognizable brand names such as Nike and Adidas.



Figure 1 – Nike Sport Ball Pump

Pros: Compact, easy to use, inexpensive, brand recognition

Cons: Traditional pumping method, no needle storage



Figure 2 – Bike Pump

Pros: Fast pump time, durable, some have needle storage

Cons: Large, expensive, traditional pumping method



Figure 3 – Miniature Bike Pump

Pros: Compact, easy to use, durable, stainless steel

Cons: Expensive, traditional pumping method, no needle storage



Figure 4 – Squeeze Pump

Pros: Non-traditional pumping method, compact, lightweight

Cons: Not very durable, limited pressure, long pump time

Market Research:

The research from our business team demonstrates the commercial potential for our product. Potential customers for our ball pump include athletes, recreational users, coaches, teams, clubs, and schools. While anyone who owns a sports ball is a potential customer, our primary market is “Fit Consumers”, defined as the 50 million adult Americans who exercise at least three times a week and participate in at least one sport every chance they get. Fit Consumers are highly affluent and represent an attractive target for marketers of products and services tied directly to their active lifestyle, such as fitness equipment, health clubs, sporting goods, athletic shoes, outerwear, and nutritional supplements. With an aggregate household income of \$2.2 trillion, Fit Consumers represent a unique and fast-growing segment of the American consumer economy. Fit customers are made up of 71.9% males and 28.1% females, with 50.6% being under the age of 30 and 27.3% having a total household income greater than \$100,000. (*Brown, Elizabeth Robert, and Ruth Washton. Fit Consumers in the US. Rep. Rockville: Packaged Facts, 2007. Print.*). We have determined through a market size estimate of fit consumer populations that capturing 15% of the fit consumer market in America at a \$5.00 price point would yield a total yearly revenue of about \$2.4 million. However, our market is not limited to athletes and coaches, but is open to anyone who owns a soccer ball, football, volleyball and/or basketball.

The business team has also visited local sporting goods stores to determine the most commonly carried sports balls, pump brands and types, and their location within the store. They found that Sports Authority and Big 5 carried only traditional tube-style pumps from \$5-\$10 and all pumps were located in the ball section. Ball pumps can be qualified as “complimentary goods” in the way that they must be purchased when a sports ball is purchased. Thus, online manufacturers such as Amazon try to bundle sports balls with a pump. Because of this idea of “if I have a ball, I need a pump,” we are exploring the option of making our mini ball pump keychain an item that would be placed by the register at check-out as an impulse buy.

Related Patents:

Due to the fact that this product has patentable aspects, the first stage of ideation was to research existing patents. The patents that were researched for this project can be found in Appendix C, but the important points are discussed in this section. Several patents exist for various pumping techniques for sport balls. The first patent found is a design which calls for a handheld squeeze pump, similar to the one in Figure 5. This patent demonstrates the usage of rubber bladders as a method of inflation. This type of design will be considered later during the ideation. Also seen in Figure 5, another patent describes an innovative ball pumping method in which the pump is actually located within the ball. This product may be considered as a competitor since it is trying to satisfy the same need. Within the patent, a crank design is presented. This cranking method is a consideration as an alternative to the traditional pumping method.

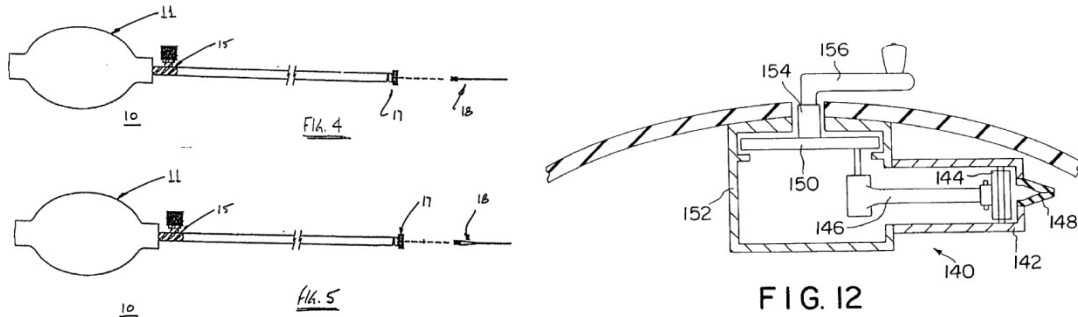

Figure 5 – On left, image from patent #20010038798A1 showing the squeeze pump and rubber bladder. On right, image from patent #6409618B1 showing a self-contained crank method.

Later in the ideation, a concept will be considered which uses a wave design to drive the piston. This idea originally came from the telescopic camera lenses. This mechanism uses rotary motion to create linear translation by using a wave groove. A wave concept will be relevant later in the design stage. In a different patent, a drill design uses pressure to rotate an output shaft through a waveform. Like the camera lens, this is another example of translating rotary motion into a reciprocating linear motion.

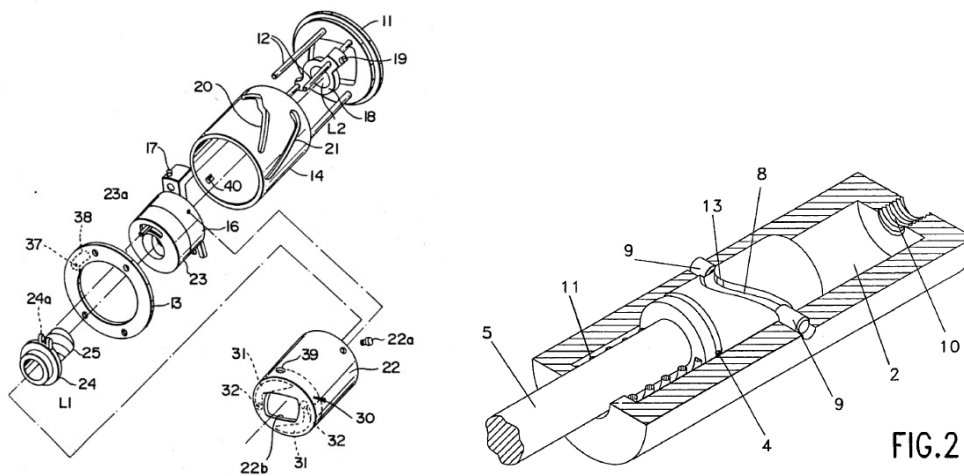

Figure 6 – On left, image from patent #5214462 showing a telescopic camera lens. On right, image from patent #5467684 showing wave groove for rotary to linear motion conversion.

As this project progresses, the patent research will evolve. The goal of the final design is that the product does not infringe on any existing patents and will be patentable itself.

Material Research:

The main manufacturers of sport and ball pumps are large corporations, such as Nike and Adidas, and typically manufacture their pumps from thermoplastics. Injection molding parts is a low cost and high volume manufacturing process. For our product to be successful, low cost is a major design requirement so we have been researching plastic injection molding techniques. As part of our research into the manufacturing of plastic products, we consulted Dan Waldorf in the industrial manufacturing department. Dr. Waldorf gave us guidelines about the do's and don'ts when designing for plastic manufacture (see Figure A-1). Waldorf also pointed us to several relevant research books available in the library.

We have also performed extensive research on the various thermoplastic materials that could potentially be used for our product. After reading E. Alfred Campo's *The Complete Part Design Handbook*, we have narrowed the materials search down to three plastics: Acrylonitrile-Butadiene-Styrene (ABS), Polypropylene (PP) and Polystyrene (PS). The pros, cons, and some engineering properties of these plastics can be seen in Table 1, below.

Table 1 – Properties of potential thermoplastics.

	<i>ABS</i>	<i>Polypropylene (PP)</i>	<i>Polystyrene (PS)</i>
Pros	-impact resistant -high strength -light weight -low cost	-light/low-density -good fatigue resistance	-low cost -good rigidity -very processable
Cons	-moisture during injection molding must be <0.2%	-degraded by UV light (i.e. sun)	-subject to stress and environmental cracking
Modulus (MPsi)	0.3	0.17	0.45
Strength (kPsi)	5.0	4.0	6.0
Melting Temp. (°F)	185-240	330	212

Design Requirements and Specifications

A list of engineering specifications for our product was derived using the Quality Function Deployment (QFD) method with consideration of requirements of our target customers. This method involved first identifying the four main categories of consumers who would buy our product: ball owners, sports enthusiasts, coaches, and sporting goods companies. Next, we constructed a list of customer requirements (i.e. compact, durable, low cost) and ranked how important these features are to each category of consumers. The factors that contribute to these customer requirements were identified and their relevance to each requirement was ranked. Finally, we identified our target values for each of these factors and compared these target values to current products on the market. The “House of Quality” in which these numbers and rankings are tabulated can be seen in Figure B-1.

The factors which were identified to be contributors towards our customer requirements will be verified for compliance using applicable testing methods. These testing methods for compliance were broken up into analysis (A), physical testing (T), similarity to existing designs (S), and inspection (I). Furthermore, the risk of meeting each of the specifications was characterized as high risk (H), medium risk (M), or low risk (L). The complete list of engineering specifications is expressed in Table 2, below.

Table 2 – Engineering Specifications for Mini Pump.

Spec. #	Parameter	Target value	Tolerance	Risk	Compliance
1	operating pressure	15 psi	max	H	T, S
2	force to operate	3 lbs	max	H	T
3	avg. pump time	60 seconds	max	M	T, S
4	allowable force on case	200 lbs	max	L	T, S
5	cost to manufacture	\$5.00/pump	±\$2.00	L	A
6	selling price	\$10.00	max	L	A
7	size	5 in ³	max	M	T, I
8	life	5 years	min	L	A, S
9	weight	1 lbs	max	L	A, T
10	comfortable crank time	3 minutes	min	M	T
11	pinch points/sharp edges	0	n/a	L	A, I
12	glass transition temp.	200 °F	min	L	A
13	aesthetics (% surveyed)	60%	min	L	A, I

Design Development

Our general design approach was to develop several rough concepts in the form of multiple sketches (Table 3). We then weighed the pro and cons of each design and determined that a crank driven design held the most promise for innovation. The crank design would have the advantage of faster and more ergonomic cranking input. We then developed three crank driven designs with some associated analysis to prove feasibility.

Initial Design Sketches:

The initial design sketches placed an emphasis on the type of pumping motion and user interface. Table 3 summarizes the pros and cons of each design.

Table 3 – Initial design sketches with summary of each design’s pros and cons.

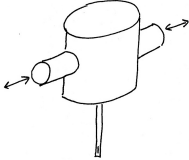
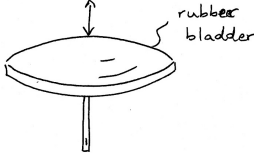
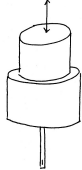
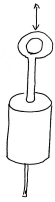
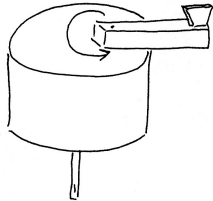
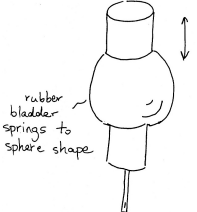
	 <p>#1</p>	 <p>#2</p>	 <p>#3</p>
Pros	The squeezing motion used to operate this design is intuitive and compact.	Simple, low cost, compact design.	This spring loaded push design represents an improvement over the traditional push-pull pumps.
Cons	Low volume design with complex internal mechanism.	Very low volume would require long pump times and many pump cycles.	Spring mechanism adds resistance to the pump stroke.
	 <p>#4</p>	 <p>#5</p>	 <p>#6</p>
Pros	Plays off the traditional push-pull pumps.	Cranking is a more natural and fluid input that linear push-pull input.	2-inch diameter rubber bladder supplies same volume as existing small push-pull pumps but with a smaller package size.
Cons	Lacks innovation.	Complex internal design.	Low durability and potentially difficult input at higher pressures.

Preliminary Concept Selection:

The goal of this project was to create an innovative product solution for pumping small balls. Based on that criterion, the concept that held the most potential for innovation was the crank driven design. The two major variables in pump design are pump volume and pump rate. Traditional push-pull pumps have a high volume and a relatively low pump rate. The crank design offers an opportunity to increase pump rate and thereby decrease required pump volume. This decrease in volume will allow for a more compact pump while maintaining the same inflation time as the competing products.

After selecting the crank driven concept, three different types of drive mechanisms were considered. The first concept utilized a gear mechanism, which translated angular motion to a power screw. The second concept was a traditional piston design using a connecting rod and driver. The final concept was also a piston design; however, this design was driven using an oscillating wave pattern. The three designs are discussed in more detail below.

Geared Mechanism:

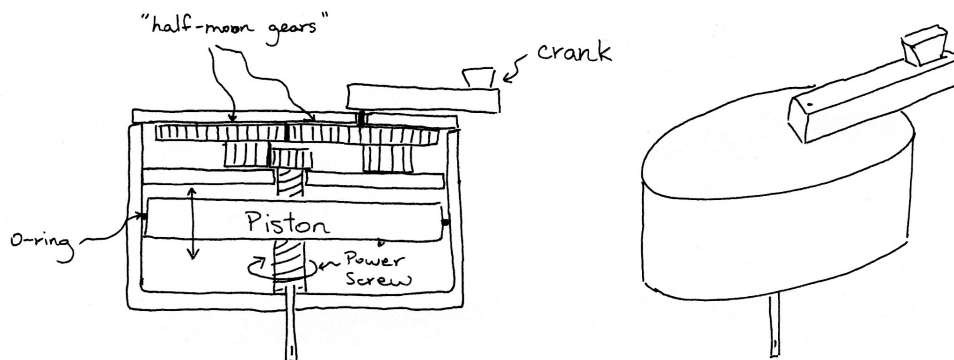

Figure 7 – Sketch of internal gear mechanism and outer case.

The geared design uses two special gears to translate the rotational motion of the crank into bi-directional motion of a power screw. The power screw then moves the piston within the cylinder. Two unique features of this system are the special "half moon" gears, and the oval shape of the piston and cylinder. The special gears seen in Figure 8 are designed to reverse the direction of the power screw with every half revolution of the crank. The two half moon gears rotate in opposite directions. The pinion attached to the power screw is only in contact with one gear at a time. Depending on the gear that the pinion is in contact with, the piston will translate either up or down. To constrain the piston to only translate horizontally, and to prevent the piston from rotating, both the piston and cylinder are made into corresponding ovals.

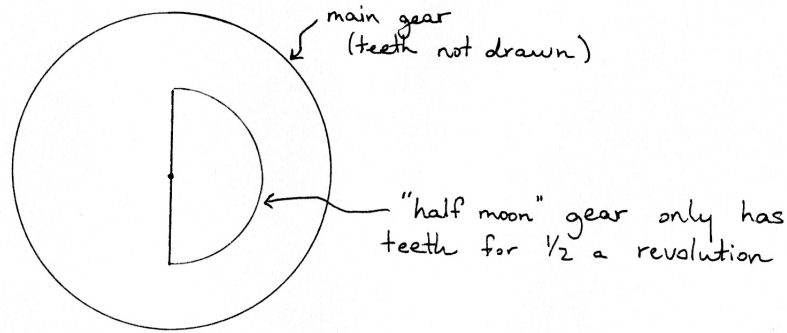

Figure 8 – Simple sketch of the proposed “half moon” gear.

A MATLAB model was developed to estimate the torque required to operate this design and to evaluate the strength requirements for the gears. Using equations from Shigley's *Mechanical Engineering Design 9th edition*, the torque requirement to operate the power screw was calculated and then the gear ratio was used to calculate the torque needed to operate the crank. The results show that a 2" diameter piston working against 10psi of pressure would require 10.5in-lb of torque to operate the crank. Additionally, plastic gears 0.1" thick satisfied the gear bending requirements. More detailed analysis and results are available in Appendix D.

The key advantage of the power screw design is the low torque required to turn the power screw. However, while the low pitch of the power screw threads makes turning easy, it also means that the screw must be turned several times to complete one piston stroke. The gears in the design allow for a variety of tuning options by allowing the designer to control the number of revolutions per crank that the power screw turns through.

The key disadvantage of this geared design is the complexity of the gears themselves. If during operation, a tooth were to break or possibly be skipped, the piston would no longer fully compress in the cylinder or might crash into the bottom of the cylinder. This would cause jamming of the pump, yielding it worthless. Because of the high complexity and high number of parts, this design would have a relatively high cost to produce and assemble.

Connecting Rod Design:

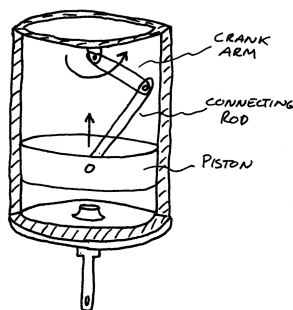

Figure 9 – Cutaway sketch of connecting rod design.

Similar to traditional reciprocating engines and pumps, this design incorporates a piston, connecting rod and driving crank. For this idea the user applies a torque to the driving crank, which in turn moves the piston through the cylinder, forcing air into the ball.

After modeling the system with free body and mass acceleration diagrams (Appendix E) Equation E.1 was developed to determine the torque required by the

user. The challenge associated with this concept was balancing the stroke length versus the torque required by the user, which affected the volume of air that could be delivered per stroke. The limiting factor in this design is the crank arm. The length of the crank arm dictates the stroke as well as the size of the product. In order to produce an operable design, the following pump dimensions were used: length of the connecting rod was 2", length of the crank arm was 1", piston surface area was 1in² and the constant internal pressure was 10psi. Based on these parameters, the torque required to turn the crank was 11in-lbs.

The connecting rod design has several distinct advantages. The first advantage is that this is a traditional proven design for reciprocating pumps. Also this design features a low part count, which is ideal for manufacturing considerations. The straightforwardness of this concept provides for simple analysis of the components.

Despite the advantages of this design, the concept has drawbacks. As mentioned before, the stroke of the pump is based upon the length of the crank arm. However, by increasing this length the total package size is affected negatively. This concept has limited design flexibility in order to obtain the desired pumping effects.

Wave Mechanism:

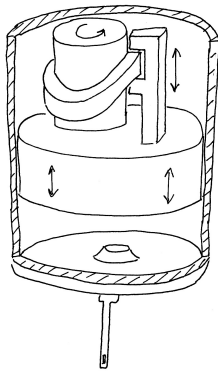

Figure 10 – Cutaway sketch of wave driven design.

The wave driven design operates like a large power screw. It improves upon the geared design by eliminating the gears while maintaining the advantage of using a power screw to decrease the torque required to turn the crank. As seen in Figure 10, the piston is linked to a driving wave. As with the geared design, both the piston and cylinder are oval shaped which prevents the piston from rotating, constraining it to translating up and down in the cylinder. With this concept, manipulating the period and amplitude of the wave allows the designer to balance pump stroke and crank torque requirements.

A MATLAB model was developed to predict the torque required to operate the crank. Appendix F contains the free body diagram and the developed equations used to analyze the system. Because the effort required to turn the crank varies with position along the wave, in order to more accurately predict the response of the system, the MATLAB model includes an ideal gas approximation of the pressure within the cylinder as a function of time. The development of this ideal gas model is presented in Appendix G. When using an unmodified sine wave with an amplitude of 0.25" (stroke of 0.5"), as seen in Figure 11, the results predict that a 2" diameter piston working against 5psi and a friction coefficient of 0.15 would require a peak input torque of 6.4in-lb. However, a customized wave with 75% of the period used in the compression stage of the stroke, as seen in Figure 12, operating under the

same conditions requires a peak torque of 4.5in-lb. This represents a 30% reduction in required input torque. Appendix J contains figures showing the torque required to operate the crank as a function of time. The negative impact of modifying the wave is that the pump can no longer be cranked in either direction, it is now limited to crank in only one direction.

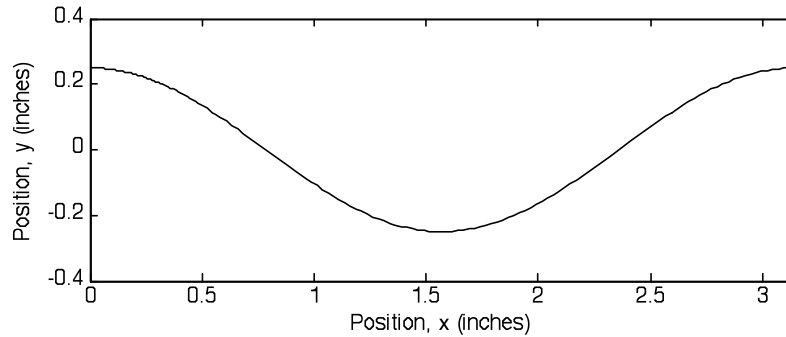

Figure 11 – Wave path with 50% of the wave in the compression stroke (0.5” stroke, 1” diameter driver).

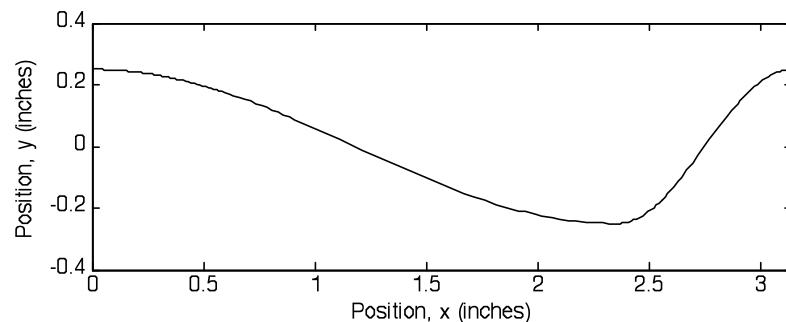

Figure 12 – Wave path with 75% of the wave in the compression stroke, which corresponds to a 30% reduction in torque over the path shown above in Figure 11.

Spring Aided Concept:

The spring aided concept is an alternative method for reducing the operating torque of the wave design. As opposed to reducing the expansion stroke of the wave as discussed above, this concept utilizes a spring during the expansion stroke. This spring would be another way to make the expansion stroke shorter. By making the expansion stage shorter the compression stage can use a smoother angle, thus requiring less input torque. Utilizing a MATLAB model, the system was simulated with various spring constants and preloaded spring lengths.

After testing different spring constants and preload combinations it was determined that the force required compressing the spring was not worth the limited response time desired. The force required by the user to turn the crank was increased during the compression stage. The limited positive effects in the expansion stage caused by the spring were not significant enough to overcome the additional force required for compression. A sample of how the response time was calculated can be seen in Appendix K, along with a comparison of the response times

and required forces for different preloads and spring stiffness's. For example, using a spring stiffness of 2lbs/in and a preload of 0.75in resulted in an additional required compression force of 3lbs with an expansion response time of 0.17seconds.

As an alternative method to reducing the torque required for the wave concept, the spring had both positive and negative aspects. The benefit provided by the spring is in the expansion stage. The spring aids the user during this stage by reducing the force and time to return the piston to the top of the stroke. However, the negative aspect is that the spring requires additional input torque to complete the compression stage.

Initial Design Selection:

After weighing the pros and cons of these three designs, the wave driven concept was selected as our initial design based on three criteria: design-ability (ability to control torque requirements), low part count (low cost), and openness to innovation (possibility for patenting). This first design is compact and uses an oval piston to reduce any rotation of the piston. Each revolution of the hand crank provides one complete wave cycle on the driver. A solid model was created in SolidWorks and a preliminary 3 dimensional view of that model is shown in Figure 13. More detailed part drawings with preliminary dimensions are included in Appendix Q. Because the wave design is non-traditional and its performance is closely linked to friction properties, as well as fluid properties, which can both be difficult to predict with high confidence, it is necessary to test multiple prototypes prior to finalizing the design. Our second design is presented in detail later in this report.

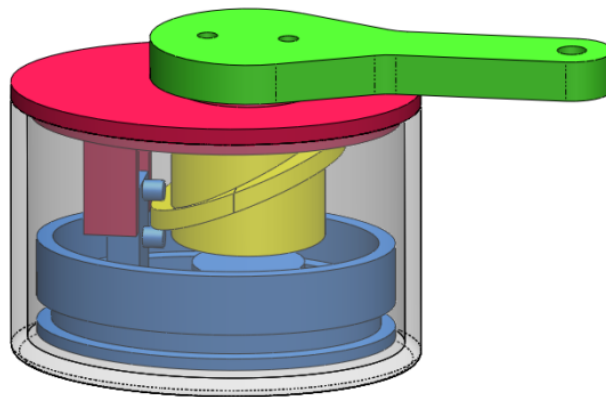

Figure 13 – SolidWorks model of initial wave design.

Preliminary Testing

In order to obtain more accurate values to use in modeling the pump, we conducted several preliminary tests to measure physical properties. These tests included a torque test to determine a range of comfortable cranking torques, a snap strength test to determine the force to break off connective plastic snaps, a bending test to determine the tensile strength of the rapid prototype material, and a friction test to determine the friction coefficient of rubbing plastic. From these tests, we were able to input more realistic values into our computer models and obtain more usable results.

Crank Torque Test:

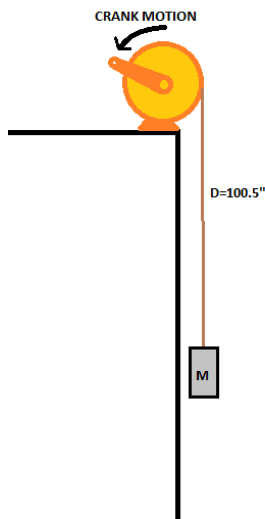

Figure 14 – Depiction of crank test apparatus.

To get a feel for how much force was ergonomically reasonable to operate using a crank arm, we conducted a preliminary crank test. We fabricated a plastic crank apparatus and wrapped a long rope around the crank’s spool. We held the crank apparatus on the railing of a balcony and hung various masses from the end of the rope. Beginning with the weights hanging off the balcony at a distance “D”, we rotated the hand crank until the weight reached the top of the balcony, allowing us to calculate an average time to crank as well as a general feel for the difficulty of cranking with a particular mass. We performed nine trials for each mass (three trials for each teammate) and obtained average crank times and rotational speeds (calculated as number of revolutions cranked divided by crank time) for each mass. A summary of these results can be seen in Table 4, below.

Table 4 – Summary of data collected for the torque test.

Mass		Crank Time for 12 Cycles (sec)	Crank Rate (RPM)	Resistance Comments
grams	lb			
295	.65	7.73	93	acceptable
590	1.3	6.58	110	acceptable for less than 1 min.
885	2.0	6.53	101	becoming uncomfortable

The average crank speed from this test was 101 RPM. Crank rate was roughly constant across the varying resistances. The range of weight that was reasonably comfortable to crank was 1.3lbs to 2lbs. We used these two values as limits to calculate a range of acceptable torque using free body diagrams of the crank apparatus (Appendix L). The torque range obtained can be seen in Table 5, and has been incorporated in our computer models.

Table 5 – Range of weight and torque calculated for torque test.

	Lower bound	Upper bound
Weight (lb)	1.3	2
Torque (in-lbs)	2.28	3.50

Bending and Friction Pre-Prototype Testing:

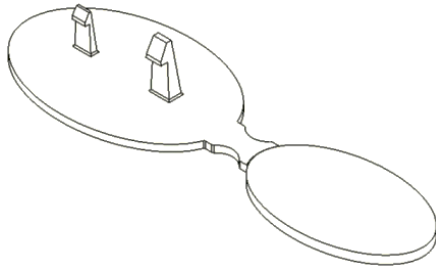

Figure 13 – Rendering of the rapid prototyped blank part.

In order to obtain rough properties of the prototype material for use in modeling, we created a rapid prototyped “blank” part that included a few features of relevance. Our “blank” was created as two disks attached together with a 0.1” thick connective piece, and included two sizes of snaps attached to one of the disk’s surface. This allowed us to get a feel for the strength of the snaps, the bending properties of the connective piece, and friction properties of the material.

Snap Strength Test:

Both sizes of snaps broke off with hardly any force, primarily due to the directionality of the material for this prototype machine. The material is laid down in layers, with poor strength between layers. This makes it very easy to break the part between the layers of material. The take-away from this test was that we need to start using the Eden rapid prototype machine for our parts, which has more homogeneous material properties.

Bending Test:

To conduct the bending test, we fixed the larger disk by holding it flat against the edge of a table. We then loaded the center of the part which was hanging off the table by progressively adding lead shot to a container. The test apparatus is shown in Figure 16. Weight was added until the connective piece between the disks yielded.

Table 6 – Summary of bend test data.

mass at yield	482.2 grams
weight at yield	1.06 lb
moment arm	1.6 in
bending strength	2714 psi

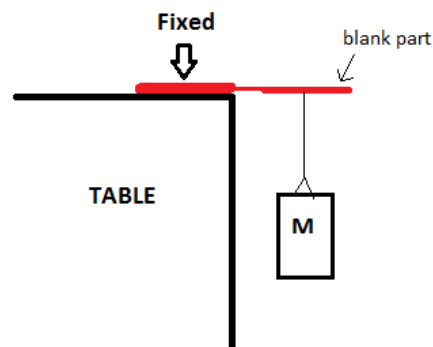

Figure 16 – Depiction of the bend test apparatus.

The calculated bending strength from this test was 2714 psi (calculations in Appendix N), only about half of the machine's rated tensile strength of 5000 psi. Furthermore, preliminary calculations predicted the weight at yield to be 2.15lbs, more than double the experimental value of 1.06lbs. We discovered that the rapid prototype was set to "conserve" mode while in operation, so the material was laid down very sparse, making it hollow on the inside with a few strands of plastic. Through this test, our conclusion to begin using the Eden rapid prototype machine was confirmed.

Friction Test:

To obtain an experimental coefficient of friction for the rapid prototype material, we used an incline plane test. As seen in Figure 17, the two disks were stacked on top of each other and inclined on a plane. The slope was increased until the top disk slid on the bottom disk. The dimensions of the incline at this slipping point are shown in Figure 17, below. A more complete development of the friction test including the development of the equations used to calculate the coefficient of friction are included in Appendix M.

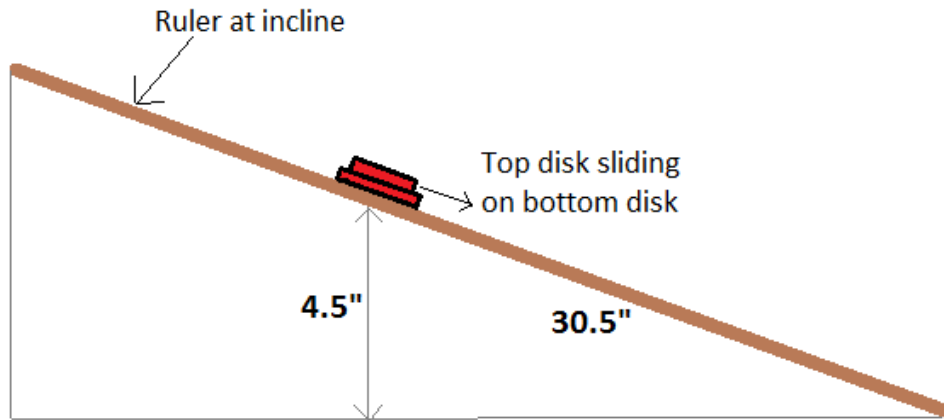

Figure 17 – Depiction of friction test apparatus annotated with dimensions at slipping point.

Calculations for this test showed a friction coefficient of 0.149. Friction plays a large role in our pump design, and we had previously been using a friction coefficient of 0.5 in our models. The significance of this test's results was that the friction in our pump will be less than anticipated, giving us more design flexibility.

Prototype #1: Testing and Observations

The first prototype was created on the Eden rapid prototyping machine in February 2012 and was found to possess both positive and negative features. First off, the material provided good strength that matched up with hand calculations. The fasteners also worked well, and the valves were effective in providing air passage during the correct stroke. The lubricant used worked well to reduce friction, and the wave design was shown to reduce torque. Furthermore, the machine tolerances were all within .001", confirming the accuracy of the prototyping machine.

However, several design limitations were discovered through this prototype. First, the off-center driver with a point of attachment on one side was found to create jamming as the crank was rotated. A moment was created, causing the driver to become misaligned. Secondly, the air holes in the seat for the umbrella valve did not allow for as much air passage during the expansion stroke as desired. This issue has been easily corrected by adding more holes to increase the air passage area, as detailed later in this report. The first prototype also had excessive clearances in various places, including the attachment of the hand crank to the case top and the space between the sliding attachment point post and its structural support. Finally, the O-ring was not sealing effectively and was creating high friction due to the piston's oval shape.

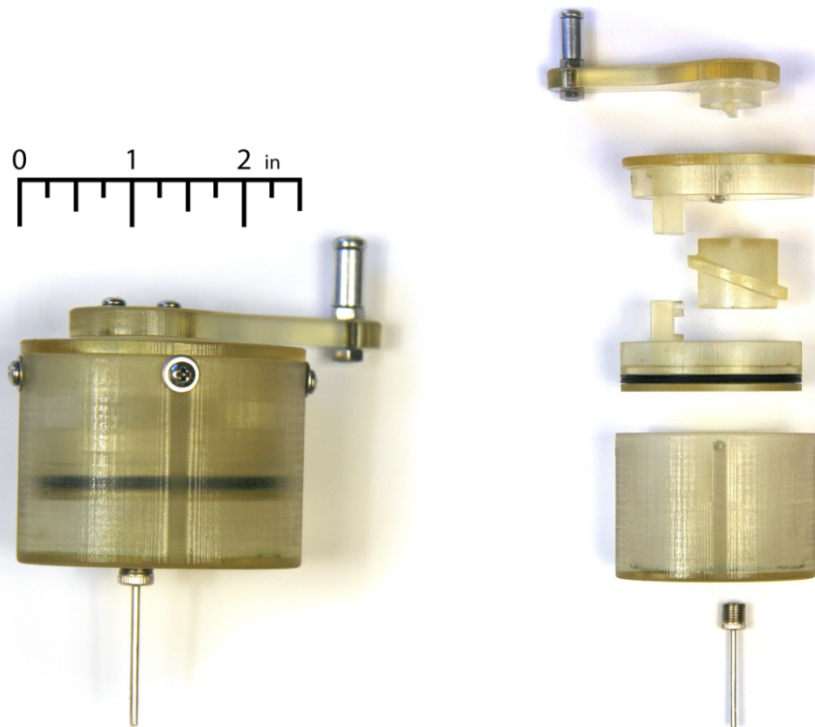

Figure 18 – Two views of prototype #1: assembled pump with approximate scale (left), and an exploded view of the components (right).

Final Design

Several improvements were made for the final pump's design. To get rid of the moment causing jamming within the pump, the driver was centered within the pump and two attachment points to the wave were included on each side of the driver to balance forces. The piston was made smaller and circular to reduce the O-ring friction and lower the force to operate the pump. Thus, a smaller O-ring is used for the final design. The links for the attachment pegs are connected to the cylinder with pin connections to allow for slight rotations of the links to prevent jamming as the cylinder translates up and down. The pegs on the cylinder to which the links attach involve a material step to decrease bending stress at the wall of the cylinder. The analysis of this bending stress can be found in Appendix N. To account for the decrease in pressure due to the decreased piston area, the period of the wave on the driver was cut in half so that two full wave cycles are completed with one revolution of the driver. Finally, additional air holes were added at the valve seat (for a total of 8 holes) for the expansion stroke to allow more air passage into the pump.

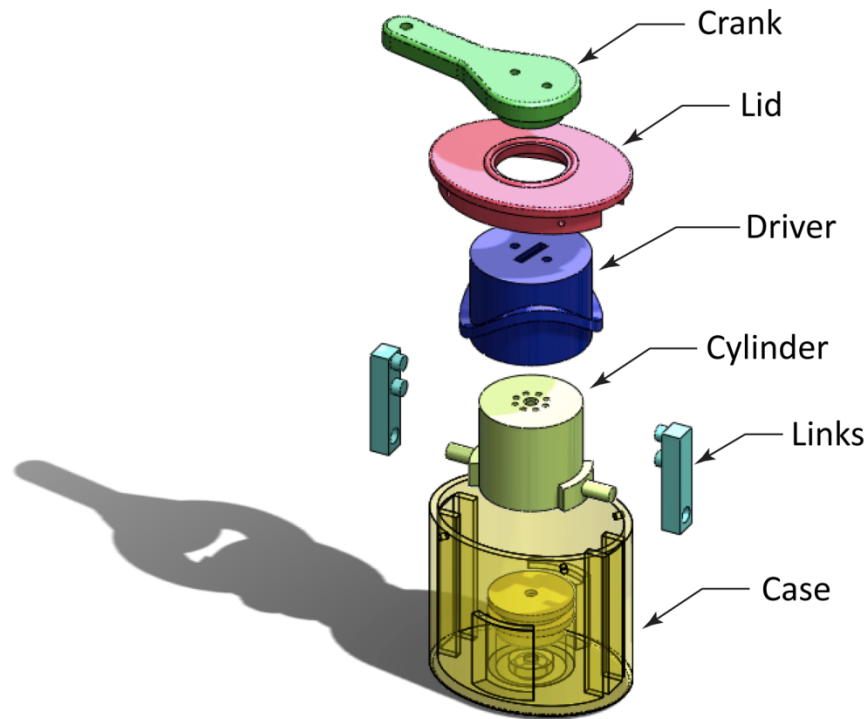

Figure 19 – Exploded view of the final design with part names.

Hardware

The final design of the pump includes the following additional hardware: fasteners to connect the various parts (see assembly drawing in Appendix Q), one X-ring valve to be attached to the piston, an umbrella valve for the expansion stroke, and a duckbill valve for the compression stroke.

X-ring:

High amounts of friction between the piston and case in the first prototype using a standard O-ring were observed. Thus, the final design will use an X-ring, which is similar to an O-ring but has a cross-section in the shape of an X. This shape mitigates friction and also allows lubrication to be stored within the outer groove of the X-ring itself to further reduce friction.



Figure 20- X-ring schematic

Valves:

Various shapes and sizes of valves were ordered from Minivalve International, a company that develops and manufactures miniature, self-actuating valves. An umbrella valve was chosen for the expansion stroke of the pump. The umbrella valve has an umbrella-shaped flap that is pushed down upon compression to block air flow. During the expansion stage, atmospheric air is sucked into the valve seat holes underneath the valve, effectively lifting up the umbrella flap and allowing air to pass through the holes and into the air column.

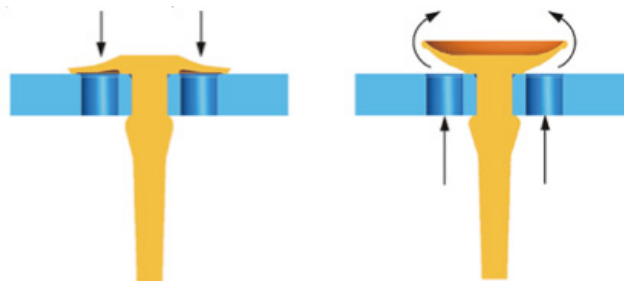

Figure 21 - Umbrella valve air flow (www.minivalve.com)

A duckbill valve was chosen for the compression stroke of the pump. The duckbill valve is essentially two flaps pressed against each other. During the expansion stroke, the flaps are closed, blocking atmosphere air flow from the outside. During the compression stroke, the compressed air inside the pump forces the slit between the flaps to open, allowing air to escape and flow through the needle and into the sports ball.

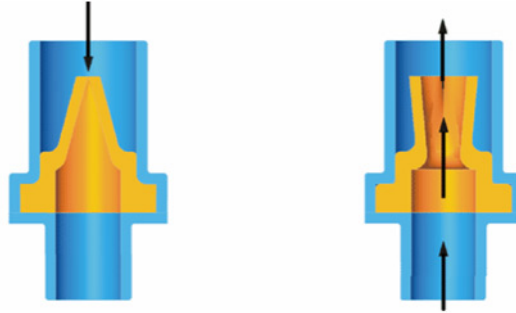

Figure 22 – Duckbill valve air flow (www.minivalve.com)

Product Realization

The final prototype was manufactured on the Objet Eden rapid prototyping machine. Several post processes were carried out on the prototype parts to assemble the pump and improve performance. These steps include wear strip installation, component bonding, surface finishing, lubrication, and assembly of the pump.

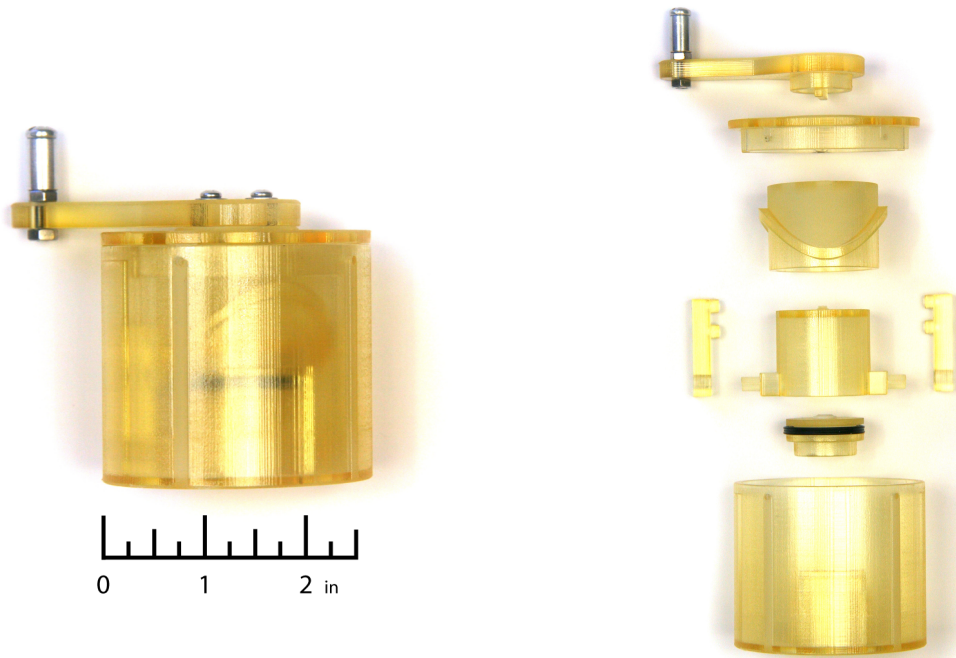

Figure 23 – Two views of the final prototype: assembled pump with approximate scale (left), and an exploded view of the components (right).

First, .0115" wear-resistant UHMW tape was installed on both the slide tracks, and linkages. This was done to lower the coefficient of friction between the slides and the linkages. It also provided wear resistance to improve the life of the prototype pump. Second, the gland cap was bonded to the housing using Devcon Plastic Welder, which is a two part plastic adhesive. The same adhesive was used to bond a thread insert into the bottom of the case. This insert was taken from an existing ball pump and provided the interface between the pump and the inflation needle. Third, the inside of the cylinder was polished with a wire brush and sanded smooth using 220 grit wet dry sandpaper. These processes helped to increase the bore of the cylinder and decrease friction between the cylinder and x-ring. The 1.125" x-ring was installed on the gland cap. The MiniValve duckbill valve, CV082.001-154.01, was installed into the gland cap and the umbrella valve, UM085.004-151.01 was installed into the cylinder. Liberal amounts of Tri-Flow lubricant were applied to the cylinder, x-ring, linkages, slides, and wave of the pump. Tri-Flow is a mineral water based lubricant with PTFE lubricating particles. The

pump crank was fastened to the driver wave using #4 bolts, washers, and nuts. The pump was then assembled and the case top was fastened to the case using four #4 machine screws and four #4 flat washers.

The prototype created for this project would differ in several ways from a commercial version of this product. These changes include design for injection molding, a clip attachment, needle storage, and a folding crank. The final prototype served as a proof of concept to demonstrate that the crank design was a viable ball pumping solution.

A commercial version of this pump would be manufactured using a plastic injection molding process. Injection molding has special design considerations which include draft angles, and thin uniform wall thicknesses on the parts. The pump has been designed with these features in mind but further design for manufacture changes would need to be made to the existing design. Furthermore, the prototype pump was designed for the strength of the Objet Eden material. ABS plastic is stronger and more wear resistant than the Eden material. This would enable many pump components to be smaller.

Three features that would improve the functionality of the pump would be a clip, needle storage, and a folding crank. A clip would enable users to fasten the pump to a sports bag, or backpack. This would improve the portability of the pump. To prevent damaging the inflation needle, it needs to be removed from the pump after use. A convenient storage space on the pump should be provided to store the inflation needle. Another improvement on the existing design would be the addition of a folding crank. The current crank protrudes from the pump. If the crank folded flat, the portability of the pump would be improved

Cost Estimation

Since the Mini Pump is going to be mass-produced for retail, cost estimation for large production runs must be considered to prove potential profitability. Rather than establish the infrastructure to manufacture all the parts and assemble the pump, the Mini Pump would be put out to bid. *The Complete Part Design Handbook: For Injection Molding of Thermoplastics* by E. Alfred Campo contains a cost estimation procedure for bids. This formula is used to establish an initial idea for costs, which may be expected for production, see Appendix P.

The cost estimation process includes many different considerations to determine an accurate price. While the estimate includes everything from plastic resin price to taxes, the main considerations that can be designed for are resin price, part weight, and cycle time and mold design. The resin price is determined through the market and on the quality of the resin. Higher quality resin yields greater cost since the resin is of a more pure form and has more consistent properties. By use of recycled materials from both internal and external sources, according to the manufacturer, the resin cost can be maintained and lowered through waste reduction. The part weight and cycle time are properties related to the part design. Part weight is a correlation to the size of the part and machine required. As would be expected low part weights require smaller machines to form the part. Similarly, cycle time also reduces cost by lowering the amount of time the part must cool before it is removed from the mold. These two factors, part weight and cycle time, can be optimized by reducing wall thickness and overall size.

One of the most significant capital costs for injection molding plastics is the mold for the parts. The molds can range from \$1,000 to upwards of \$75,000 depending on the complexity of the parts. A separate cost estimation process for the mold was taken from the Part Design Handbook, see Appendix P. The mold cost is formulated around the part weight, the geometric difficulty, and the number and projected area of the cavities. To keep the cost low, parts had to be designed in a small simple manner. The more complex geometries that require pullouts and other additional processes add greatly to the cost of production.

Based on the methods of cost estimation as stated above and “The Rule of 4,” a preliminary cost can be obtained. “The Rule of 4” states that the final user sale price is four times the production cost. This mark up of products is only a rough estimate to account for profit gain by distributors, manufacturers and other steps in the process from producer to consumer. The following table is a financial estimate breakdown for varying production runs, the sales price based on “The Rule of 4” and the actual bid cost for production and assembly of the Mini Pumps. Also the following plots demonstrate the relationships of production cost per unit and startup cost for the differing production sizes.

Table 7 - Cost estimation of various production runs using injection molding techniques.

Production Runs						
Size	20000	30000	40000	50000	100000	200000
Production Cost	\$2.37	\$1.76	\$1.45	\$1.26	\$0.89	\$0.71
Total Cost	\$47,415.62	\$52,623.42	\$57,831.23	\$63,039.04	\$89,078.08	\$141,156.16

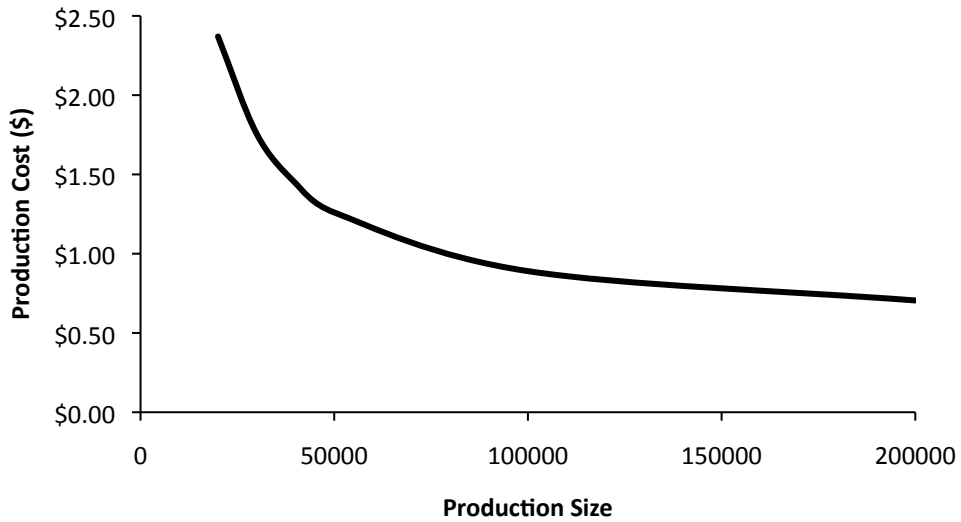

Figure 24 - Production cost per unit as a relationship to production size.

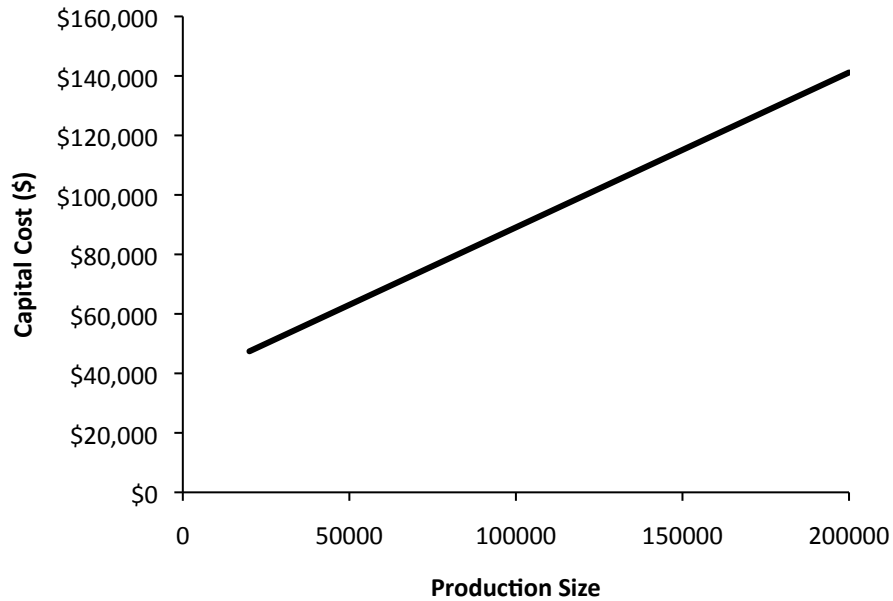

Figure 25 - Initial capital cost per production run for injection molding manufacturing.

From these interpretations it is seen that the production cost per unit decreases exponentially as the production size increases. The initial capital cost increases linearly with production size. Through “The Rule of 4” and a target sales price of \$8.00 per unit an ideal production size based on production cost and capital cost is about 75,000 units.

Finally, the cost to produce the Mini Pumps is based on foreign labor costs. Since the cost per unit is rather low, it may be financially viable to produce the parts in the United States. By manufacturing the parts locally, less hassle would occur from importation and language barriers.

Even though a Mini Pump prototype was developed and fully functional the project overall is not viable for mass production. For several reasons this second prototype will be as far as the team will pursue this idea. First, this pump while successful for some sports balls is not successful for all. The pump works for volleyballs due to the low pressures required for those, however not for the higher-pressure balls. These balls constitute the majority of the interest market. Due to the inability to reach these customers, the demand and desire for this product is dramatically decreased. With this decrease in market size, the capital required to mass-produce the mini pump has increased and will be harder to obtain. The initial capital spoken of earlier in this report of thousands of dollars would be difficult to obtain for this reduced market and a profitable venture would be even more challenging. Taking into account the time and economic investment required to move forward with this project, it has been decided to move forward in different manners.

Design Verification

The goal of the project was to create a commercially competitive ball pump. Therefore, a very practical testing approach was taken for determining the performance of the pump. The pump was tested by several different users on different ball types. The time that it took to pump the ball was recorded as well as the users response to operating the pump. These pump times were then compared to the results from the computer model. The main result of the testing was determining that the maximum comfortable operating pressure of the Mini Pump is approximately 6-7 psi depending on the user. Most sports balls have recommended inflation pressures greater than 6 psi. The recommended inflation pressure of a volleyball is 3-4 psi. This is within the operation range of the Mini Pump. The Mini Pump can successfully inflate volleyballs from soft to firm within 15-20 seconds. Figure __ summarizes recommended inflation pressures of common ball types and shows the Mini Pump's operating region.

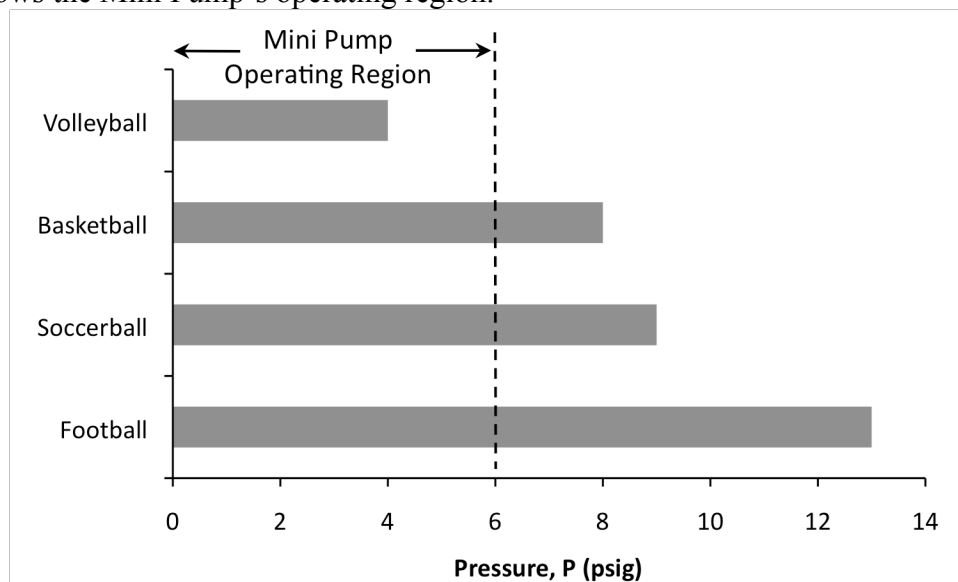

Figure 26 – Recommended operating pressures of various sports balls overlaid with the operating region of the Mini Pump.

In general users were not satisfied with the pumping motion of the Mini Pump. As predicted, the torque required to operate the pump fluctuated with each revolution. This fluctuation proved to be not ergonomic. It created a choppy feeling not associated with commercial quality products. The static friction of the seal in the pump is significantly higher than the dynamic friction of the seal once the cylinder is in motion. Because of this, the pump is difficult to get going. At slow operating speeds were static friction becomes significant, the pump will often “stick”.

Conclusion

The Mini Pump project successfully designed and prototyped an innovative original pump design that had limited functionality. While the pump was able to successfully inflate volleyball, it was unable to achieve the higher pumping pressures required for other ball types. As an entrepreneurial project, the goal was to create a commercially viable product. The Mini Pump fell short of its commercial target in two key areas: market size, and ergonomics. With volleyball as its only potential market, the target market of the Mini Pump was too small to be economically viable. Additionally, the operation of the pump was not smooth enough to be considered of commercial quality. Overall, this project was a good exercise in mechanical design.

Appendix A: Plastic Manufacturing and Rapid Prototyping Considerations

Table A-1 – Rapid prototyper property comparison.



	Stratasys FDM 200mc	Objet Eden 250
Work Platform (in)	8 x 8 x 12	9.8 x 9.8 x 9.8
Material	<i>ABSplus</i>	FullCure720, Vero and Durus
Tensile Strength (psi)	5000	8000
Tensile Modulus (psi)	360,000	375,000
Print Resolution (micron)	254	30

Part Design Checklist

for injection molded engineering thermoplastics

Material Selection Requirements

- LOADS Magnitude Duration Impact Fatigue Wear
- ENVIRONMENT Temperature Chemicals Humidity Cleaning agents
- SPECIAL Lubricants U.V. light
- Transparency Paintability Warp/age/Shrinkage
- Plateability Flammability Cost Agency test

Part Details Review

- RADII Sharp corners Ribs Bosses Lettering
- WALL THICKNESS
 - Material Electrical Flammability
 - Flow Strength Too thin Thin to thick
 - Uniformity Picture framing Orientation
 - RIBS Thick areas Thin areas Abrupt changes
 - Base thickness Radii Draft Height Spacing
- BOSSES Radii Draft Inside diameter/outside diameter
- WELD LINES Base thickness Length/diameter
- DRAFT Proximity to load Strength vs. load Visual area
- TOLERANCE Draw polish Texture depth 1/2 degree (minimum)
- Part geometry Material
- Tool design (across parting line, slides)

Assembly Considerations

- PRESS FIT Tolerances Long-term retention Hoop stress
- SNAP FIT Allowable strain Assembly force
- SCREWS Tapered beam Multiple assembly
- MOLDED Thread-cutting vs. forming Avoid countersinks
- THREAD Avoid feather-edges, sharp corners and pipe threads
- ULTRASONICS Energy director Shear joint interference
- ADHESIVE & WELD Wall thickness Hermetic seal
- SOLVENT BONDS Trapped vapors Compatibility
- GENERAL Interfit tolerances Stack tolerances Thermal expansion
- Care with rivets and molded-in inserts Component compatibility

Mold Concerns

- WARPAGE Cooling (corners) Ejector placement
- GATES Type and shape Size Location
- RUNNERS Size and shape Sprue size Balanced flow
- GENERAL Cold slug well Sharp corners
- Draft Part ejection Avoid thinking cores

• WALL UNIFORMITY •

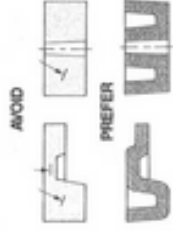

• BOSSES •

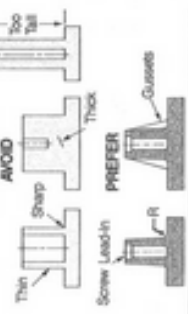

• SNAP-FIT •

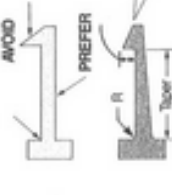

• MOLDED-IN THREADS •



• WARPAGE •

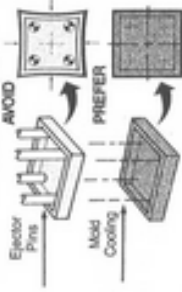

• RADII •

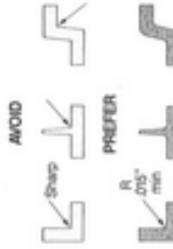

• RIBS •

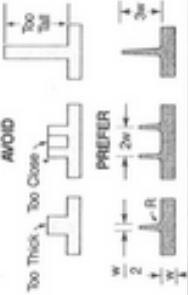

• DRAFT •

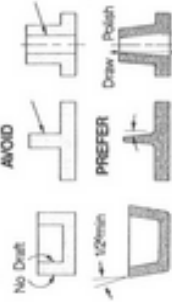

• SCREWS •

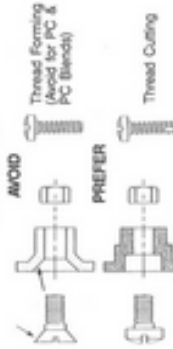

• PICTURE FRAMING •

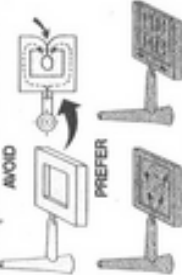

Figure A-1 – Part Design Checklist [*Plastic Part Design for Injection Molding* by Robert A. Malloy, Hanser Publishers, Munich 1994]

Appendix B: Quality Function Deployment

Table B-1 – QFD House of Quality used to develop the design requirements.

	ball owners	sports enthusiasts	coaches	sporting good companies	Max Operating Pressure (psi)	Max Force to Operate (lb)	Average Pump Time (s)	Allowable Force on Case (lb)	Cost (\$)	Size (in ³)	Life (yr)	Weight (lb)	bike pump (large)	bike pump (mini)	sport pump	squeeze pump
fast pump time	15	17	12	10	1	3	9						22	10	8	5
easy to operate	15	15	12	10	3	9							20	15	14	13
compact	9	9	15	10						9			1	6	8	10
durable	14	14	17	8				9			9		20	18	14	13
portable	9	12	13	10				3		9		3	1	8	10	11
cool looking	7	7	2	15					3	1			3	8	8	12
works on all types of balls	11	9	9	12	1	3							10	10	12	9
easy to hold	7	7	10	8						9			5	9	10	12
low cost	9	7	5	10					9				1	4	6	5
safe	4	3	5	7	3	1		1					17	12	10	10
				Units	psi	lb	s	lb	\$	in ³	yr	lb				
				Targets	15	3	60	200	10	25	5	1				
				bike pump (large)	250	15	15	300	35	300	20	4				
				bike pump (mini)	120	10	25	250	25	44	3	1				
				sport pump	20	5	50	200	10	35	3	1				
				squeeze pump	13	13	45	200	18	10	2	0.5				

- Strong Correlation 9
- Medium Correlation 3
- Small Correlation 1
- No Correlation -

Appendix C: Patent Research

Excerpts from the following patents are included in the pages that follow:

- Patent No. 6,409,618 B1
- Patent No. 2011/0038798 A1
- Patent No. 5,214,462
- Patent No. 5,467,684



US006409618B1

(12) **United States Patent**
Touhey et al.

(10) **Patent No.:** **US 6,409,618 B1**
(45) **Date of Patent:** **Jun. 25, 2002**

(54) **SELF-CONTAINED SPORT BALL
INFLATION MECHANISM**

(60) Provisional application No. 60/159,311, filed on Oct. 14, 1999.

(75) Inventors: **Daniel P. Touhey**, Lee, MA (US);
Brian P. Feeney, East Windsor, CT
(US); **Joseph E. Stahl**, Southampton,
MA (US); **Neil T. Amundsen**,
Minneapolis; **Louis F. Polk**, Excelsior,
both of MN (US); **Joseph J.
Schachtner**, Deer Park, WI (US);
Kenneth V. Schomburg, Wayzata;
George D. Stickler, Shorewood, both
of MN (US); **Richard F. Terrazzano**,
Salem, NH (US); **Eric K. Litscher**,
Hopkinton, MA (US); **Andrew C.
Harvey**, Waltham, MA (US); **Malcolm
E. Taylor**, Pepperell, MA (US); **Peter
M. de Bakker**, Hudson, MA (US);
Robert C. Sykes, Burlington, MA
(US); **Charles Keane**, Hingham, MA
(US)

(51) **Int. Cl.⁷** **A63B 37/00**
(52) **U.S. Cl.** **473/593**
(58) **Field of Search** 473/593, 610,
473/611; 446/220, 224; 417/478, 479, 480,
259, 29; 36/29

(56) **References Cited**

U.S. PATENT DOCUMENTS

362,532 A	5/1887	Patterson	
602,294 A	4/1898	Arnold	
2,698,028 A	12/1954	Lee et al.	137/539
3,020,673 A	2/1962	Cooke	
3,119,617 A	1/1964	Topper	473/593
4,975,028 A	12/1990	Schultz	417/553
5,098,095 A	3/1992	Weiss	473/593
5,238,244 A	8/1993	Cotter et al.	473/593
5,494,410 A	2/1996	Maier-Laxhuber et al. .	417/529
6,287,225 B1 *	9/2001	Touhey et al.	473/593

* cited by examiner

Primary Examiner—Steven Wong

(57) **ABSTRACT**

An inflatable sport ball, such as a basketball, a football, a soccer ball, a volley ball or a playground ball, is provided with a self-contained inflation mechanism for inflating or more likely adding pressure to the ball. The mechanism is a pump which is inside of the ball and which is operable from outside of the ball to pump ambient air into the ball.

(73) Assignee: **Spalding Sports Worldwide, Inc.**,
Chicopee, MA (US)

(*) Notice: Subject to any disclaimer, the term of this patent is extended or adjusted under 35 U.S.C. 154(b) by 0 days.

(21) Appl. No.: **09/594,980**

(22) Filed: **Jun. 15, 2000**

Related U.S. Application Data

(63) Continuation-in-part of application No. 09/478,225, filed on Jan. 6, 2000, now Pat. No. 6,287,225

19 Claims, 14 Drawing Sheets

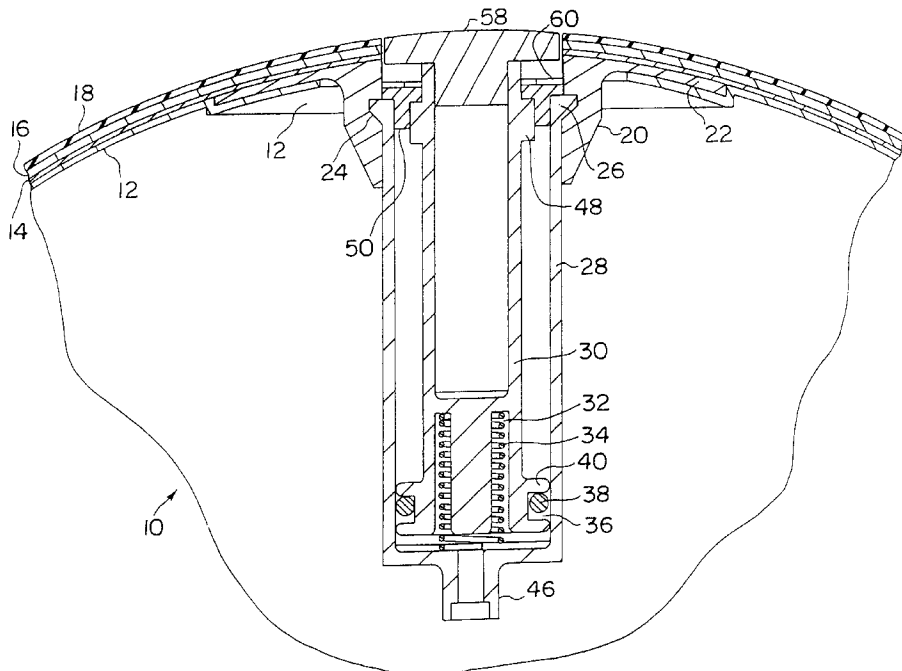

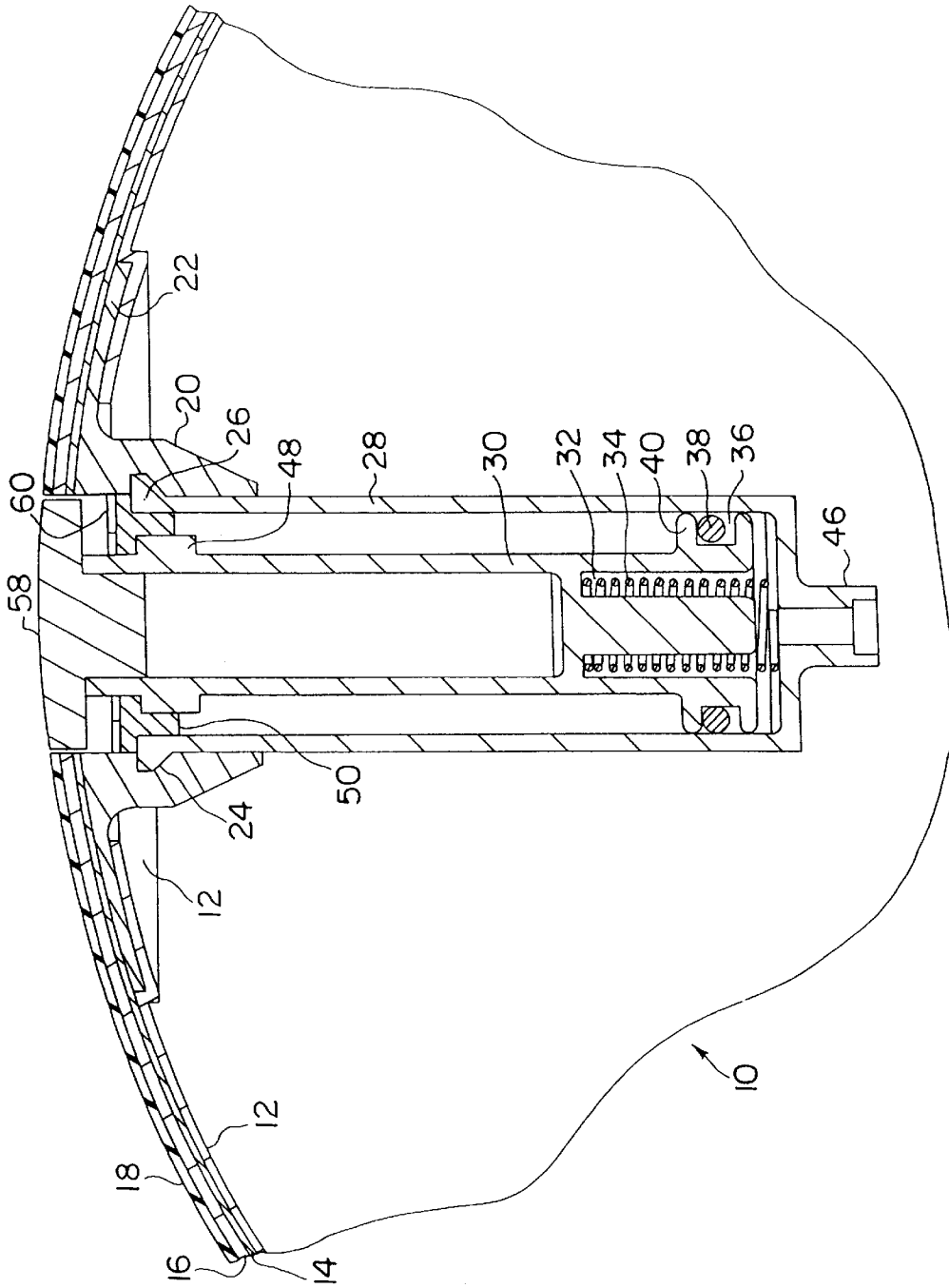

FIG. 1

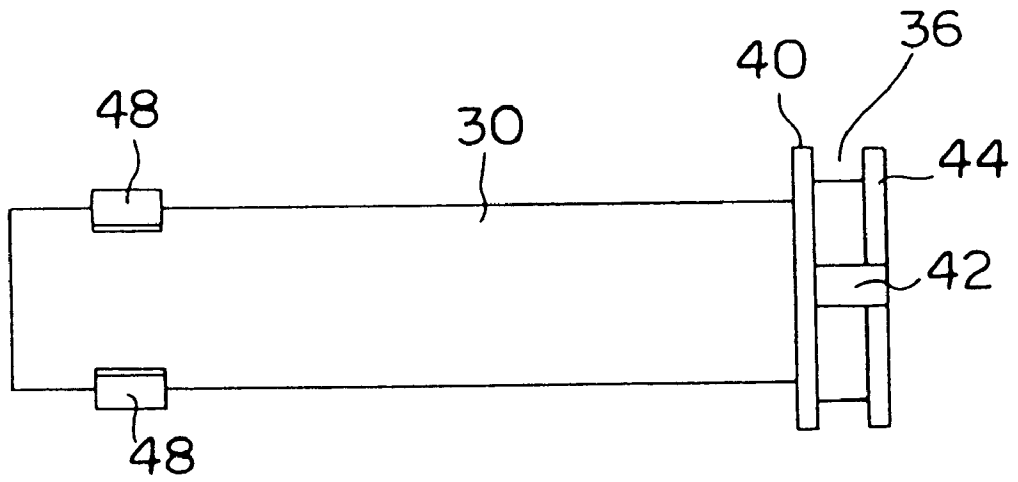

FIG. 2

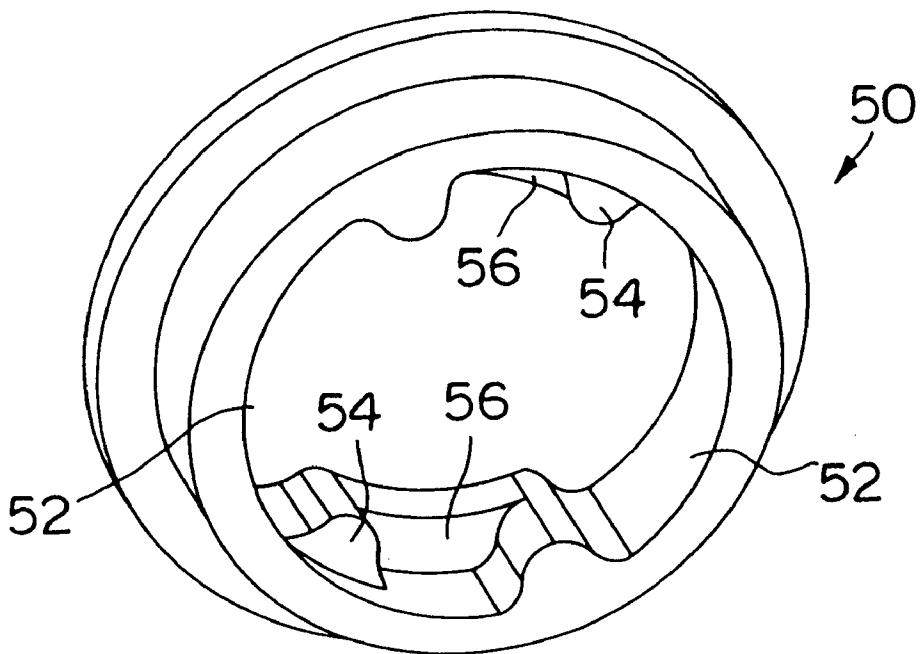

FIG. 3

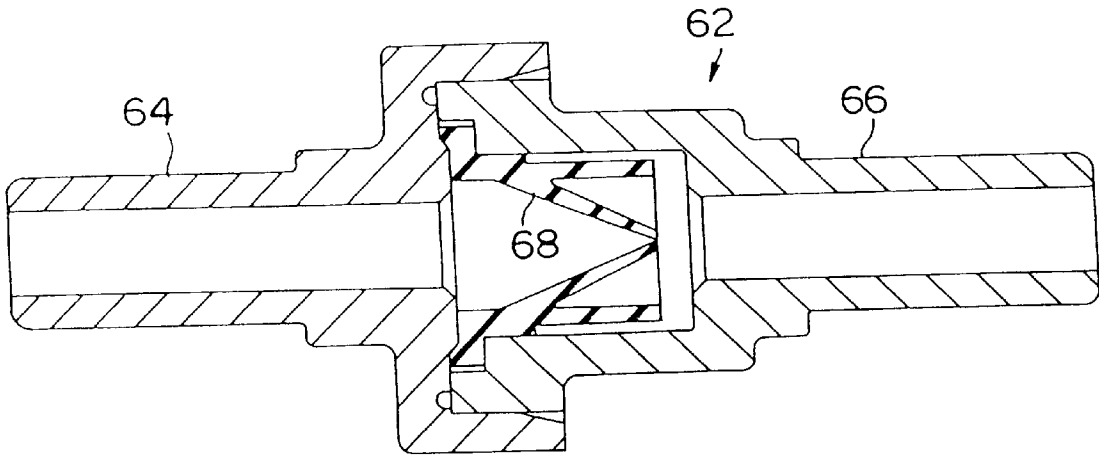

FIG. 4

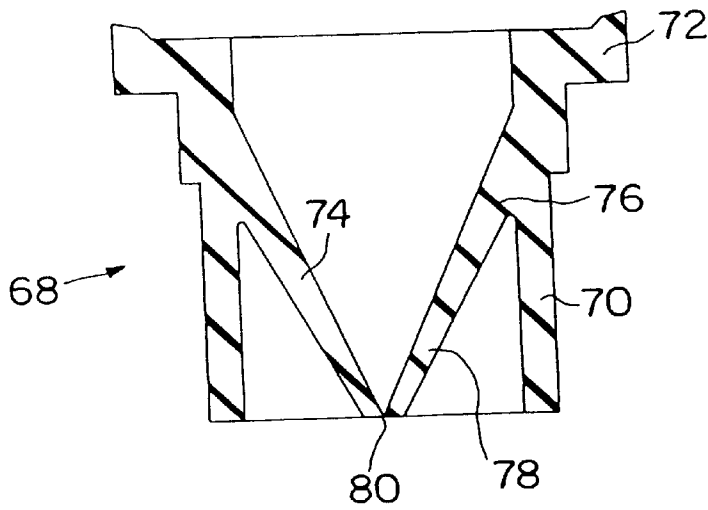

FIG. 5

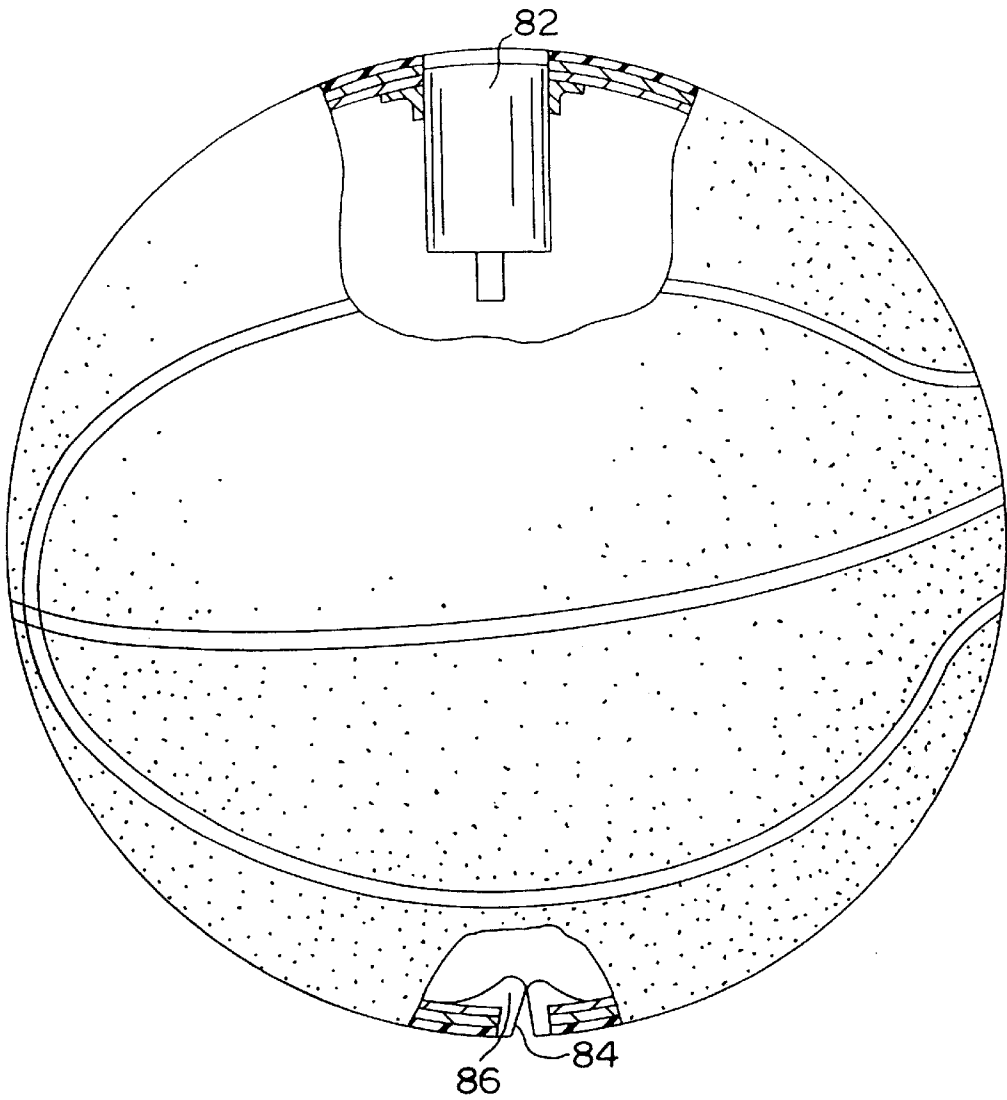

FIG. 6

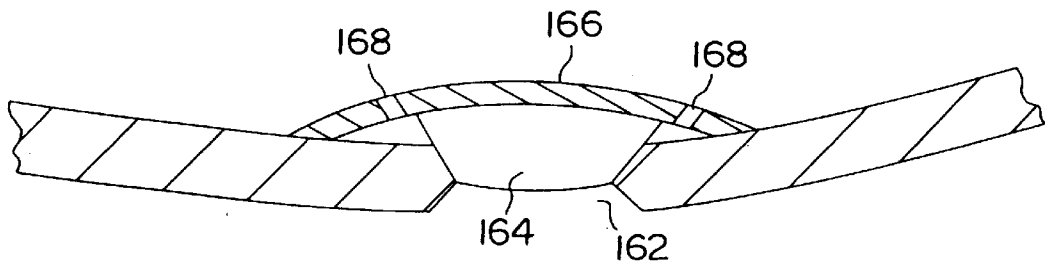

FIG. 14

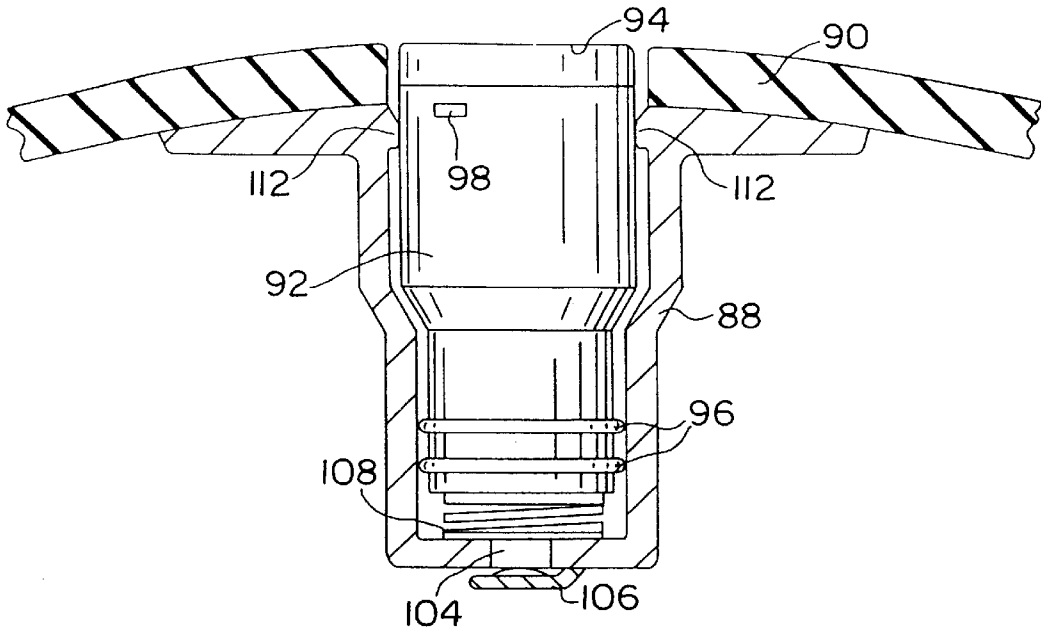

FIG. 7

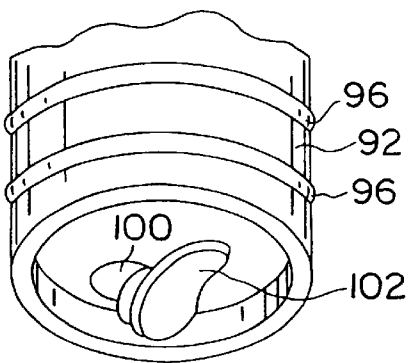

FIG. 8

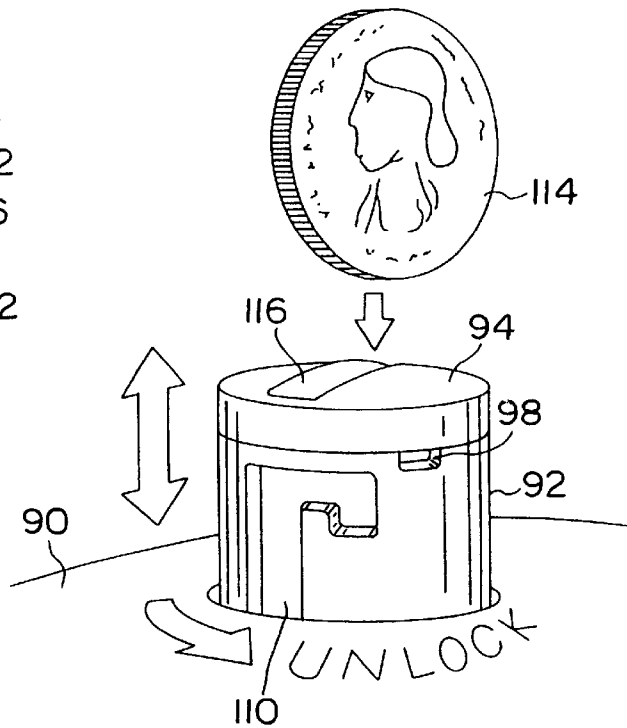

FIG. 9

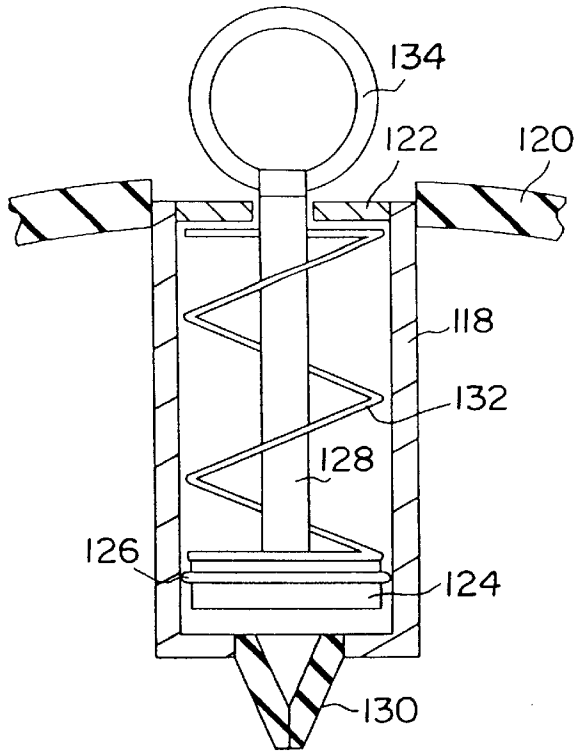

FIG. 10

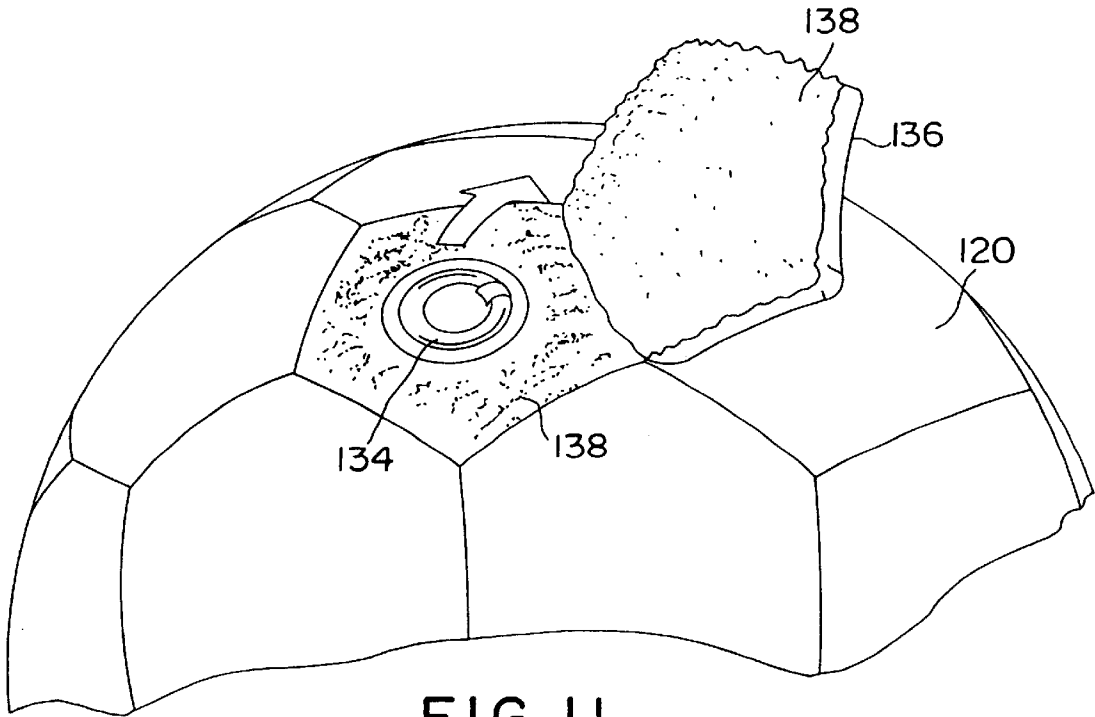

FIG. 11

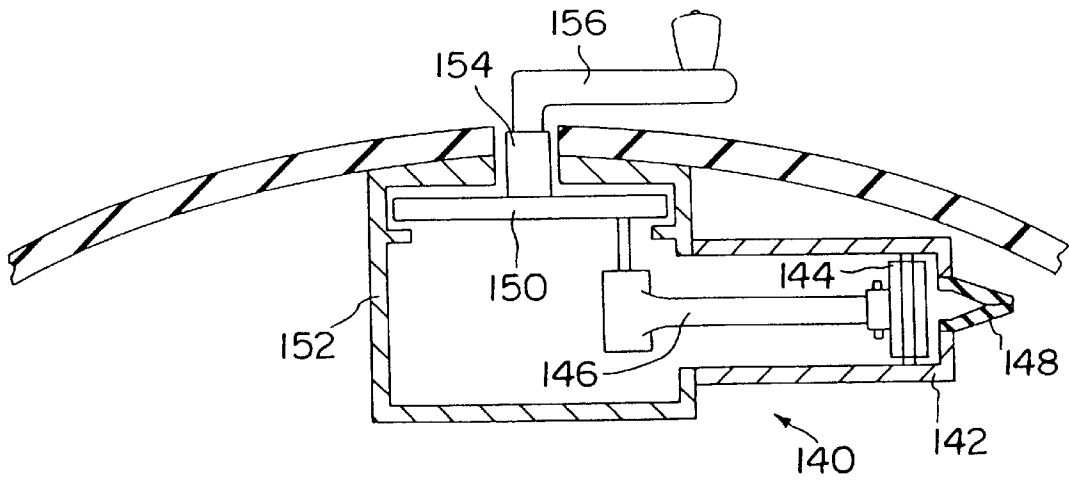

FIG. 12

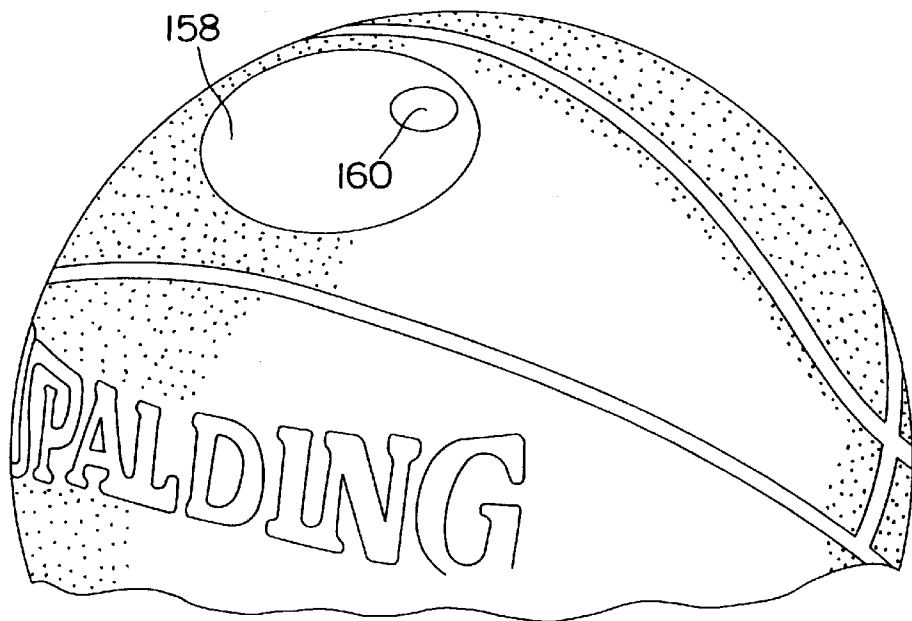

FIG. 13

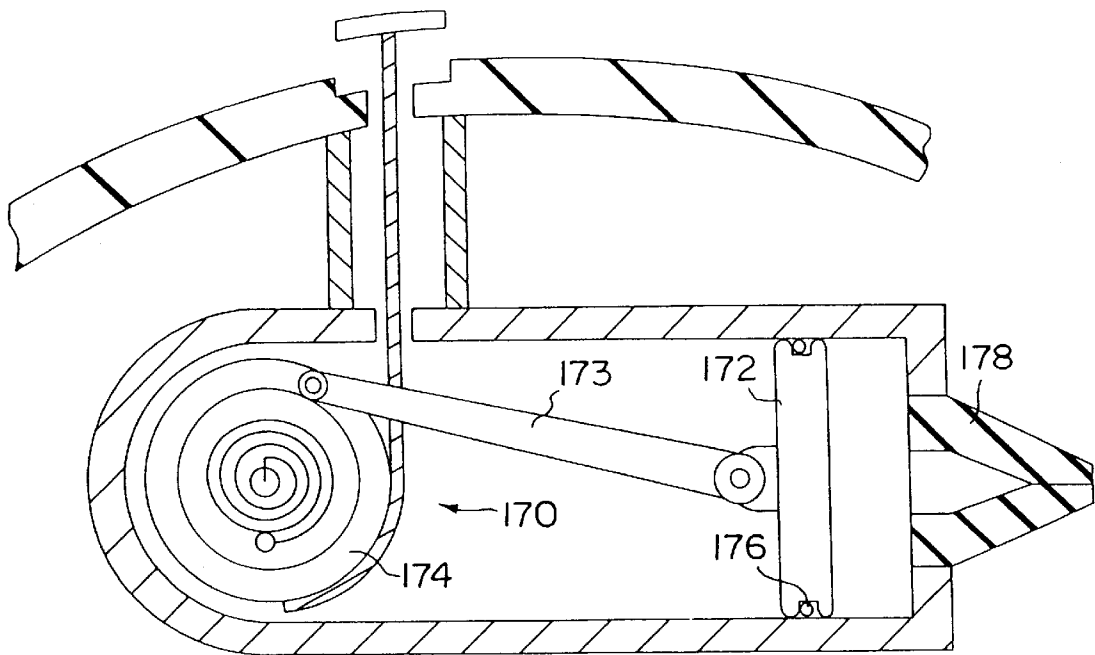

FIG. 15

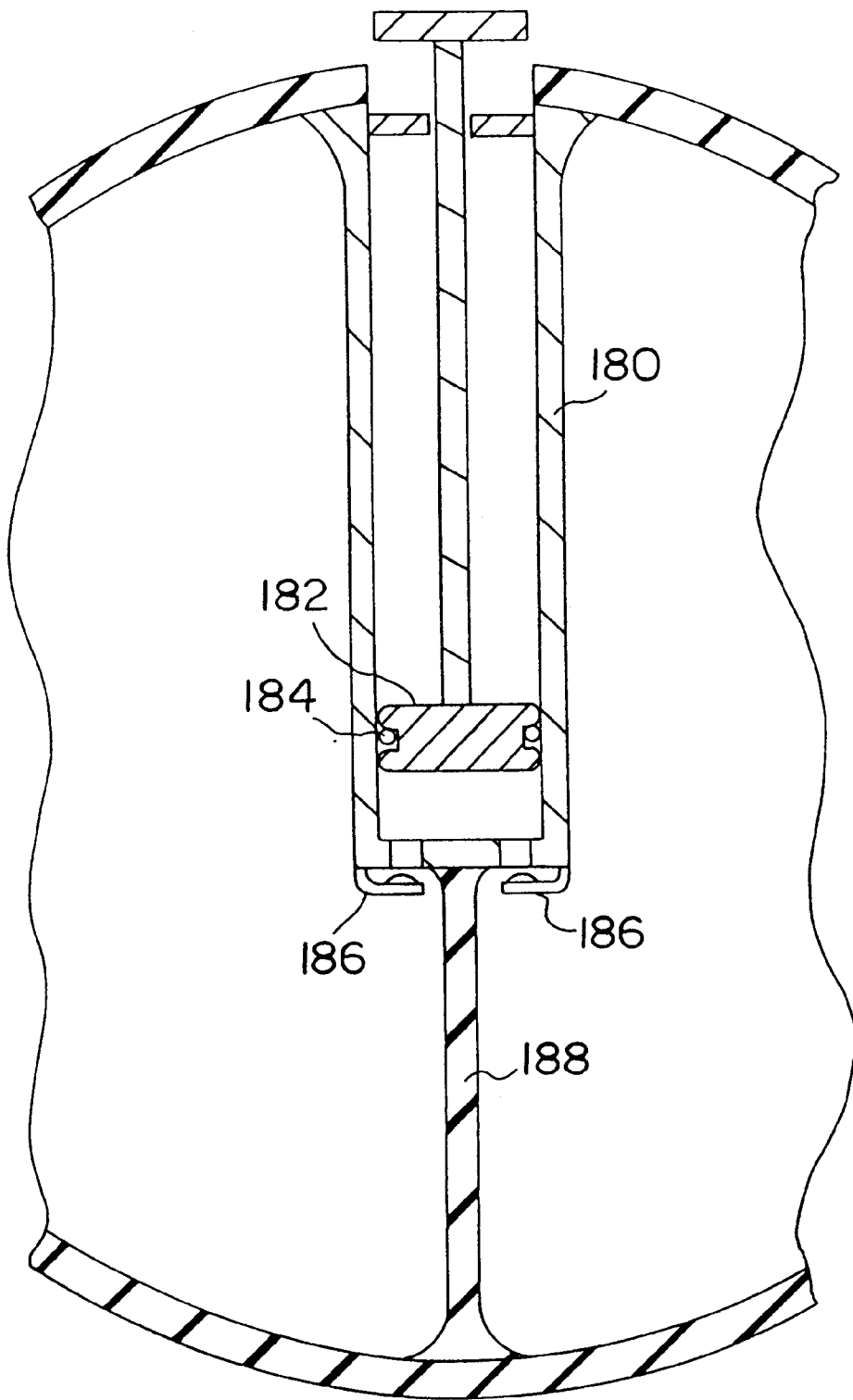

FIG. 16

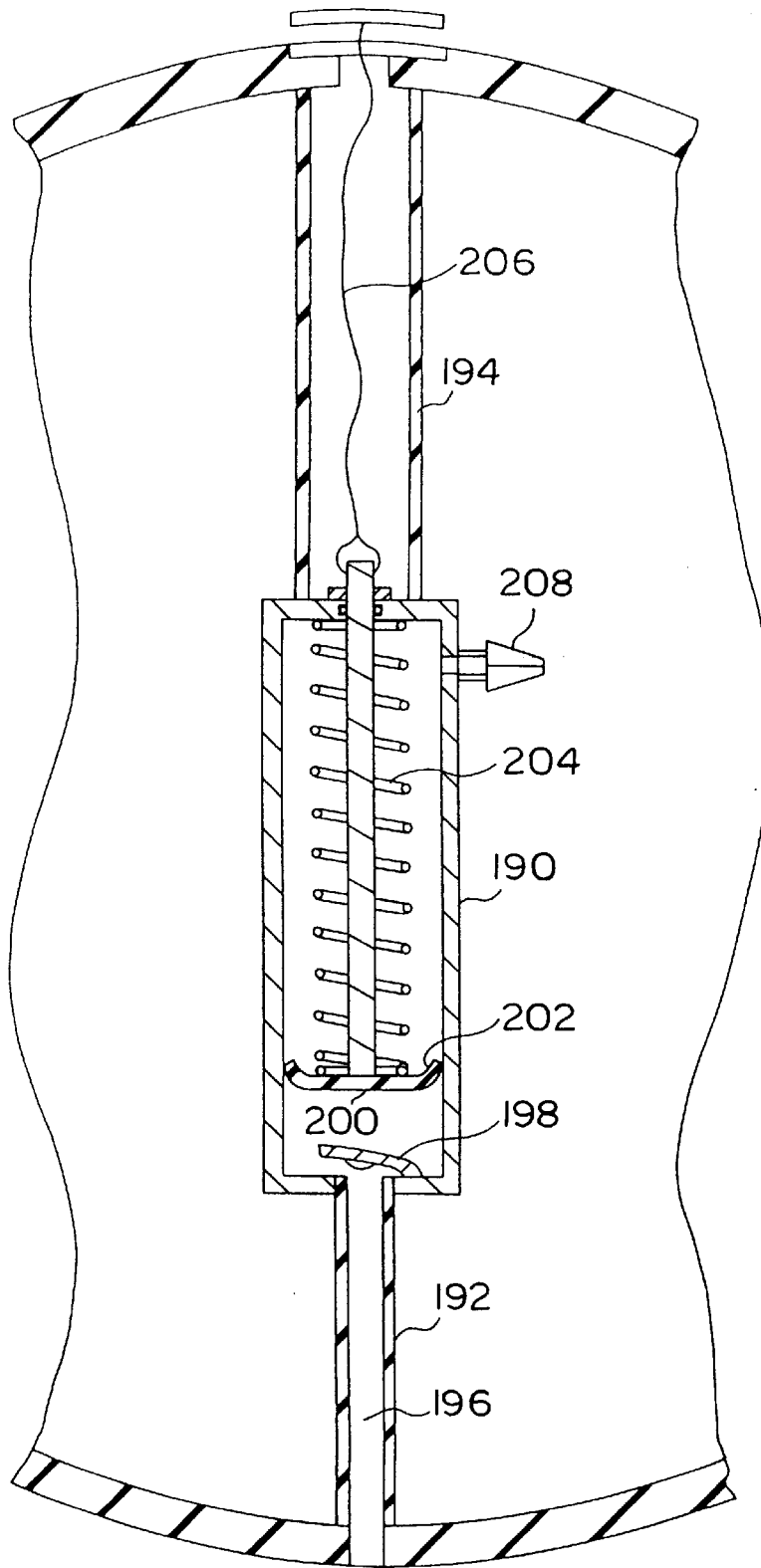

FIG. 17

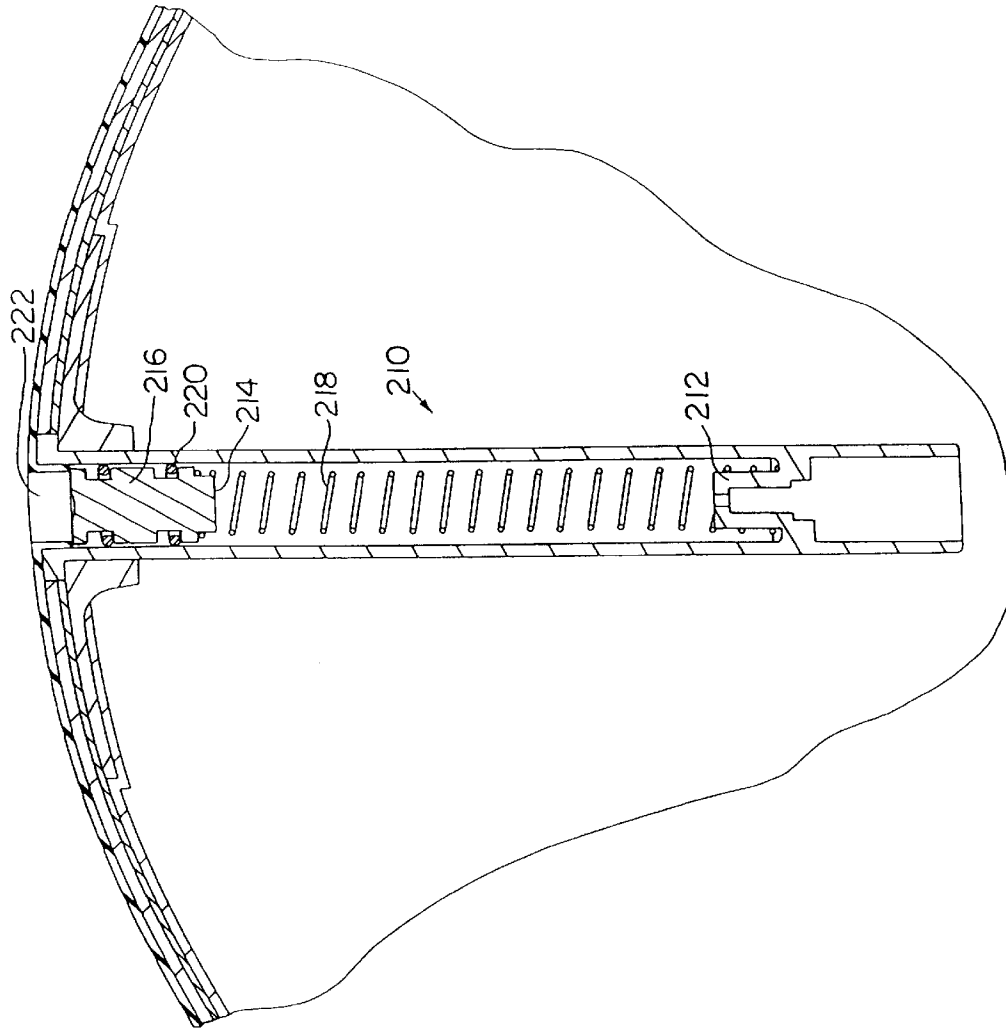

FIG. 18

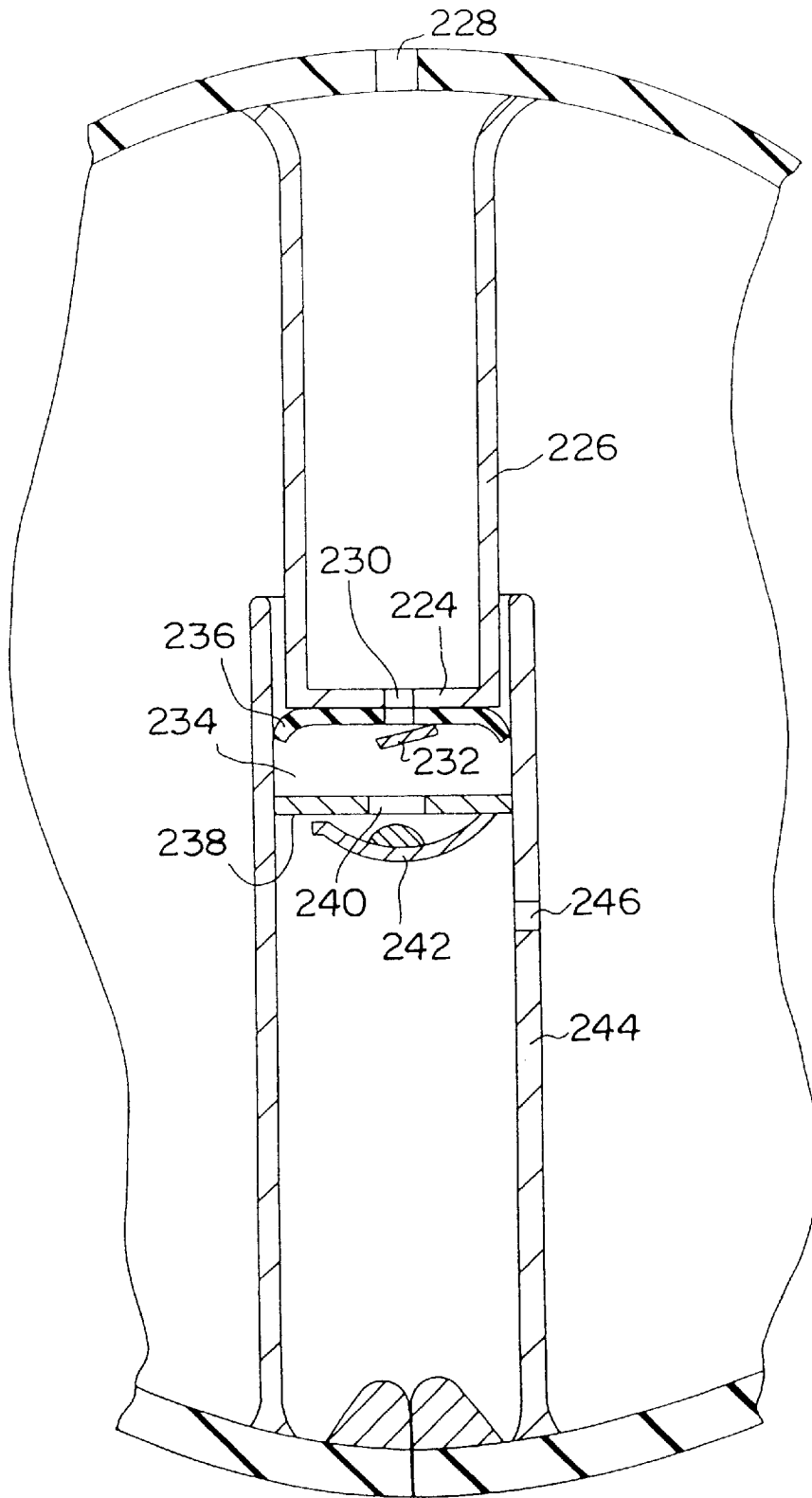

FIG. 19

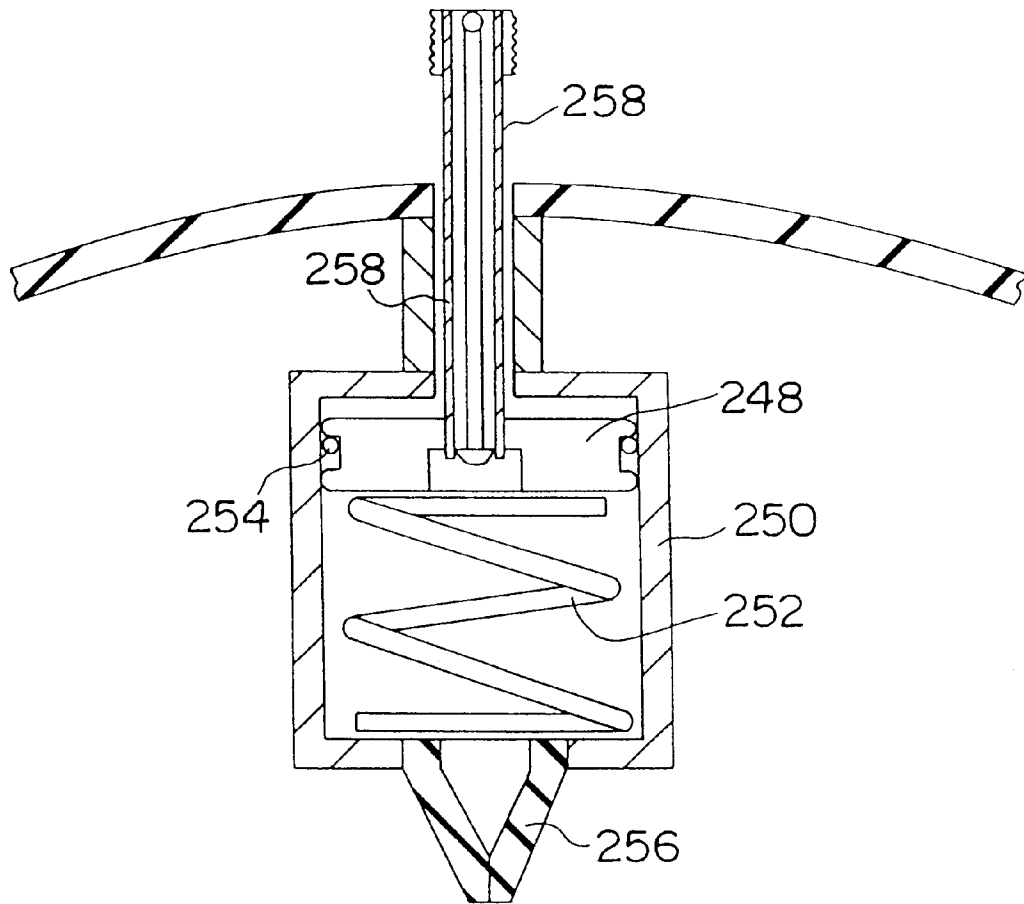

FIG. 20

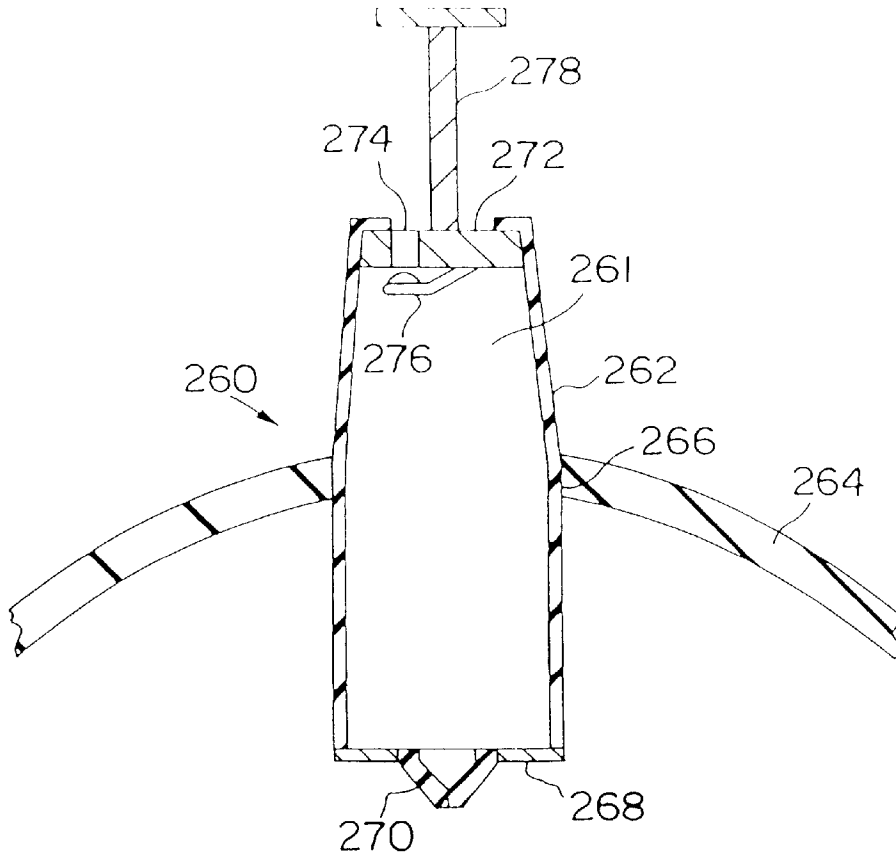

FIG. 21

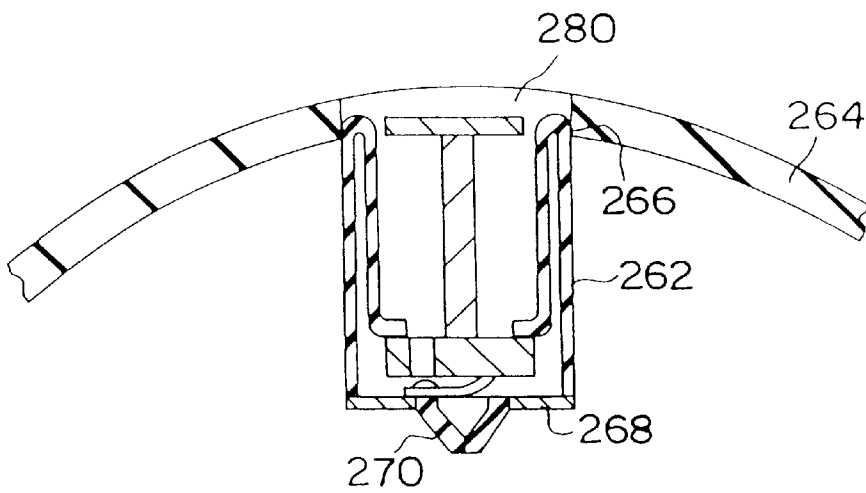

FIG. 22



US 20010038798A1

(19) **United States**

(12) **Patent Application Publication**
FOSTER

(10) **Pub. No.: US 2001/0038798 A1**

(43) **Pub. Date: Nov. 8, 2001**

(54) **PORTABLE HAND OPERATED FLUID PUMP**

Publication Classification

(76) Inventor: **FRANCIS X. FOSTER, COCONUT CREEK, FL (US)**

(51) **Int. Cl.⁷ F04B 43/08**

(52) **U.S. Cl. 417/478; 417/435; 222/209**

Correspondence Address:
KEVIN W GOLDSTEIN, ESQ.
RATNER & PRESTIA
P.O. BOX 7228
WILMINGTON, DE 19803

(57) **ABSTRACT**

(*) Notice: This is a publication of a continued prosecution application (CPA) filed under 37 CFR 1.53(d).

A hand-held and hand-operated fluid pump capable of inflating recreational equipment, as well as directing a stream of air to clean delicate electronics or hard to reach locations, is provided. The simple design of the inventive fluid pump permits it to be equally useful for creating fluid streams to dislodge foreign particles stuck in difficult to reach areas, such as corners and enclosed pipe structures. Because the inventive pump uses only human energy to transmit fluids or gases, it is ecologically efficient exemplifying a "green technology" design.

(21) Appl. No.: **08/749,090**

(22) Filed: **Nov. 14, 1996**

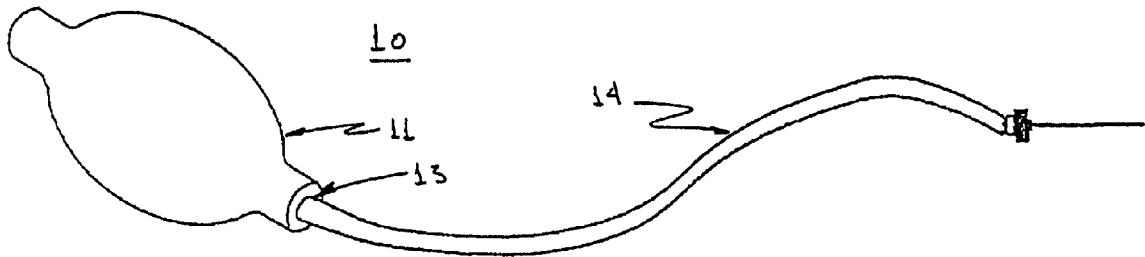



FIG. 1

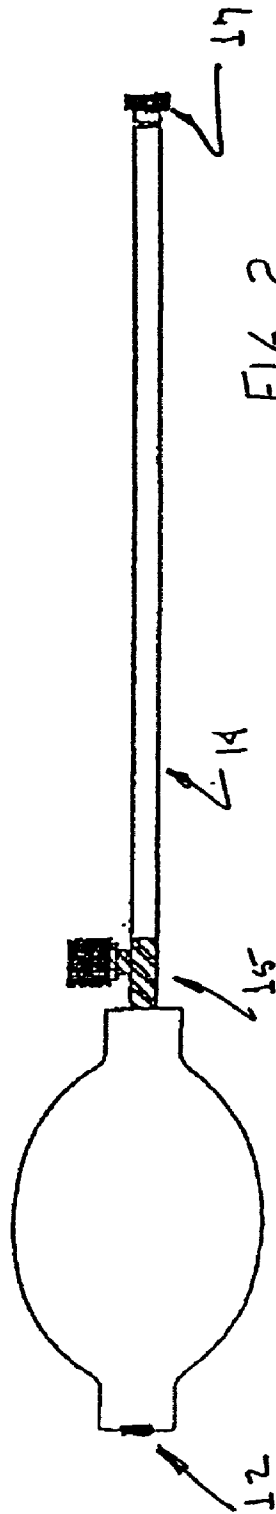

FIG. 2

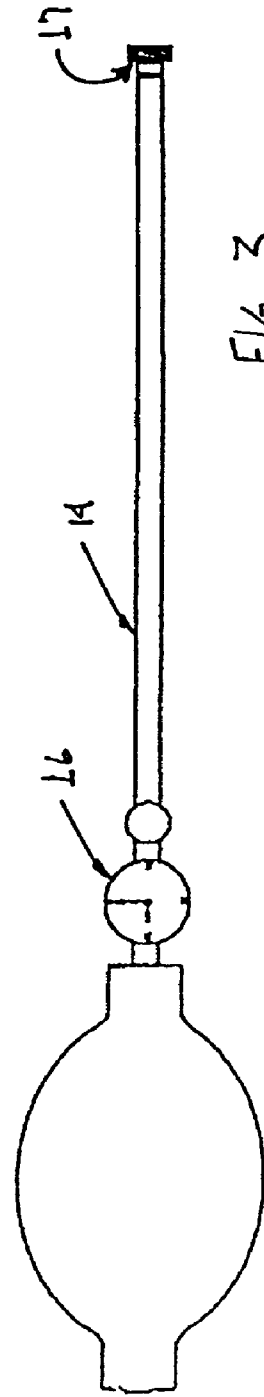
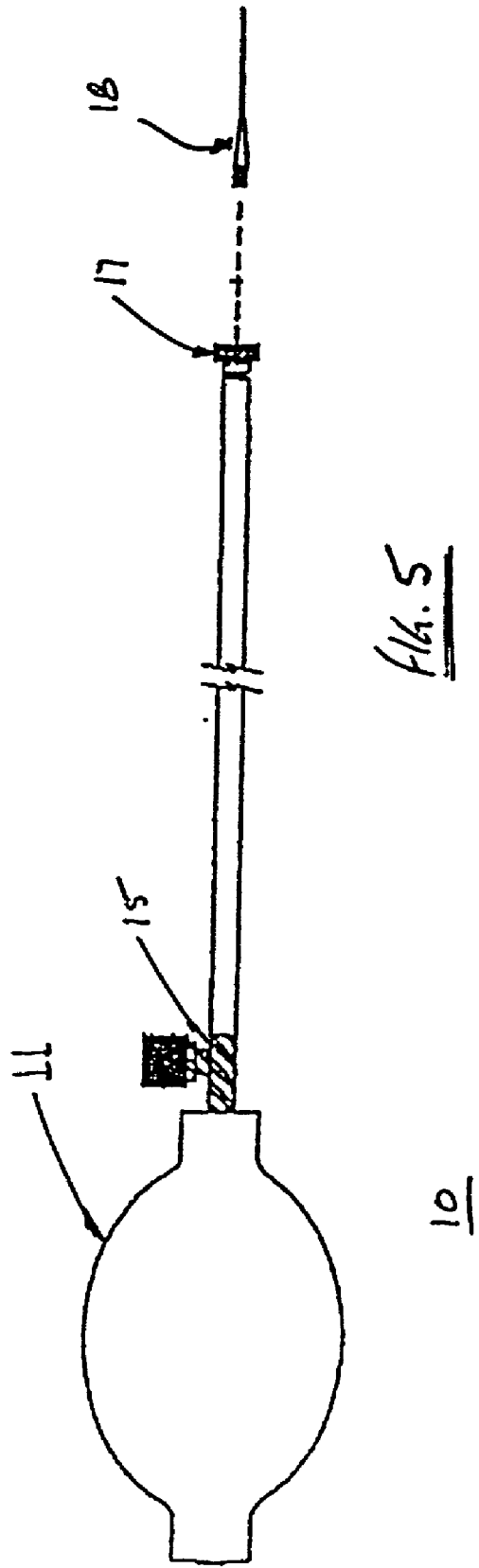
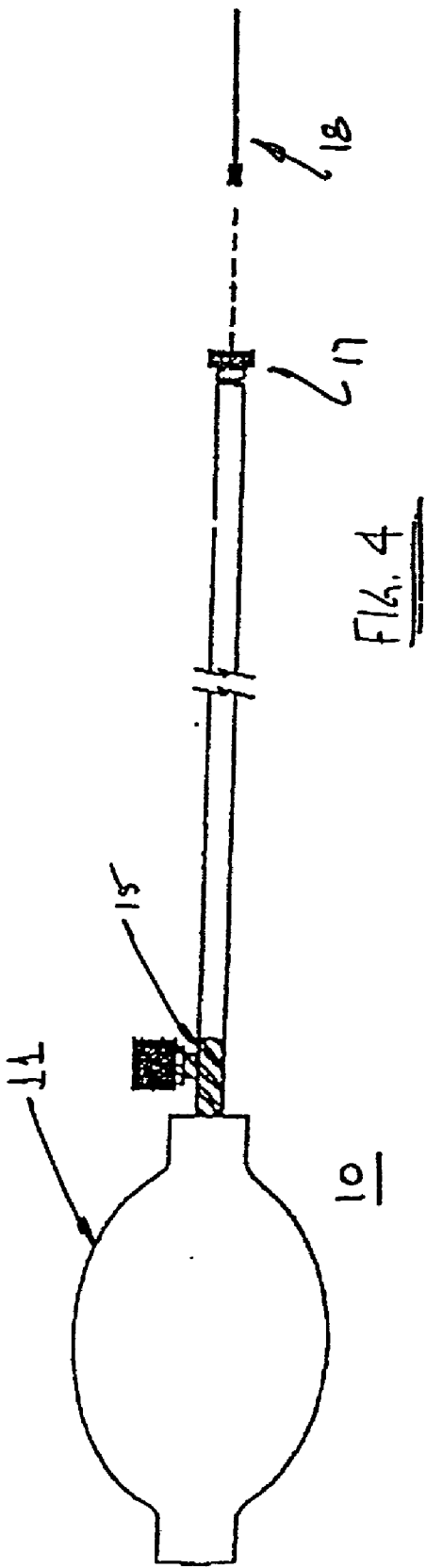

FIG. 3



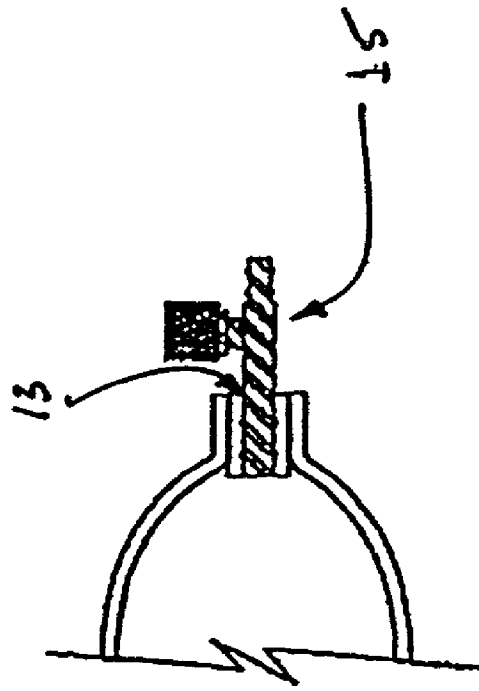

FIG. 7

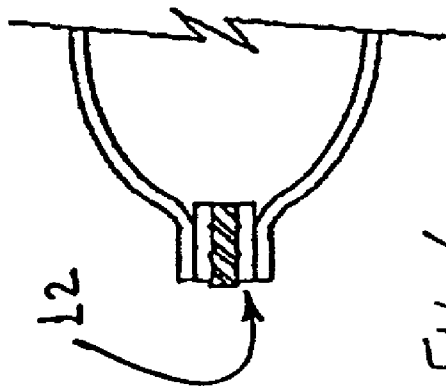

FIG. 6



US005214462A

United States Patent [19] Haraguchi et al.

[11] Patent Number: **5,214,462**
[45] Date of Patent: * **May 25, 1993**

[54] LENS SHUTTER CAMERA INCLUDING ZOOM LENS AND BARRIER MECHANISMS

[75] Inventors: **Keisuke Haraguchi; Shinsuke Kohmoto; Shigeru Kondoh; Hideki Ohkubo; Susao Nakamura**, all of Tokyo, Japan

[73] Assignee: **Asahi Kogaku Kogyo Kabushiki Kaisha**, Tokyo, Japan

[*] Notice: The portion of the term of this patent subsequent to Jan. 29, 2008 has been disclaimed.

[21] Appl. No.: **486,914**

[22] Filed: **Feb. 14, 1990**

Related U.S. Application Data

[62] Division of Ser. No. 144,030, Jan. 7, 1988, Pat. No. 4,944,030.

[30] Foreign Application Priority Data

May 12, 1986 [JP]	Japan	61-108278
May 12, 1986 [JP]	Japan	61-108279
May 28, 1986 [JP]	Japan	61-80861
Jun. 2, 1986 [JP]	Japan	61-83932
Jun. 2, 1986 [JP]	Japan	61-127496
Jun. 21, 1986 [JP]	Japan	61-145470
Jun. 26, 1986 [JP]	Japan	61-150995
Aug. 15, 1986 [JP]	Japan	61-125045
Aug. 22, 1986 [JP]	Japan	61-196911
Aug. 29, 1986 [JP]	Japan	61-132658
Aug. 29, 1986 [JP]	Japan	61-132659
Aug. 29, 1986 [JP]	Japan	61-132660
Aug. 29, 1986 [JP]	Japan	61-132661
May 28, 1987 [JP]	Japan	61-80862

[51] Int. Cl.⁵ **G03B 17/02**

[52] U.S. Cl. **354/187; 354/195.1; 354/202**

[58] Field of Search **354/187, 195.1, 195.12, 354/202, 288, 253**

[56] References Cited

U.S. PATENT DOCUMENTS

2,995,061 8/1961 Briskin et al.

(List continued on next page.)

FOREIGN PATENT DOCUMENTS

4980242 10/1947 Japan

(List continued on next page.)

Primary Examiner—W. B. Perkey
Attorney, Agent, or Firm—Sandler, Greenblum & Bernstein

[57] ABSTRACT

A lens shutter type of camera is disclosed in which a zoom lens is positioned in a lens block (1) which has a sector gear (15) rotatably associated with the lens block and with a rotatable cam ring (14). The cam ring and sector gear are rotatable in a substantially constant axial position. A movable finder optical assembly (8) and a movable strobe assembly (9) are movable in association with movement of the zoom lens. The zoom lens is movable between an extreme telephoto position and an extreme wide angle position, as well as into a fully collapsed lens position beyond the extreme wide angle position and a macro or close-up photographing position beyond the extreme telephoto position. When the camera is in its macro mode, a prism (P1) is inserted into the finder optical assembly to correct for parallax; the strobe assembly is moved to change its illumination angle; and an optical wedge (4e) is pivoted into the path between a light receiver (4) and a light emitter (3e). A single cam plate (53) is provided to move the finder assembly and the strobe assembly. The photographic aperture (22b) can be selectively closed by barrier plates (31a) when the zoom lens is moved into its fully collapsed position. A light intercepting assembly (210) is provided for preventing light from entering the photographic optical assembly via cam grooves (20 and 21). This intercepting assembly includes a flexible code plate (90) which surrounds a peripheral portion of the cam ring (14) and which provides positional information relating to the position of the zoom lens.

16 Claims, 32 Drawing Sheets

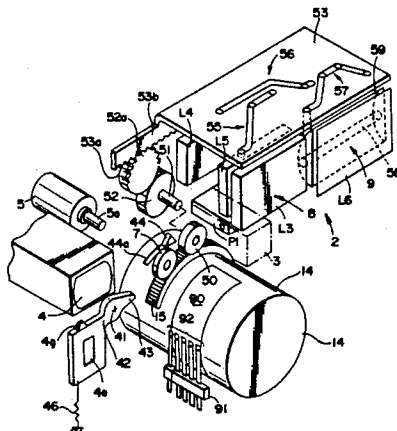

U.S. PATENT DOCUMENTS

3,701,309	10/1972	Thiele et al. .	
3,978,503	8/1976	Shono	354/250
4,043,642	8/1977	Hirose et al. .	
4,410,253	10/1983	Tsuboi	354/195.1
4,443,078	4/1984	Niwa et al.	354/403
4,445,757	5/1984	Enomoto et al.	354/195.12 X
4,508,443	4/1985	Matsuzaki et al.	354/402
4,522,478	6/1985	Kando et al.	354/288
4,596,449	6/1986	Iwata et al. .	
4,643,555	2/1987	Wakabayashi	354/195.12
4,721,972	1/1988	Wakabayashi	354/195.1
4,771,303	9/1988	Matsumoto et al.	354/195.12
4,864,338	9/1989	Wakabayashi	354/195.12 X

4,989,027 1/1991 Ishii et al. 354/253

FOREIGN PATENT DOCUMENTS

47-27020	10/1972	Japan .
50-36118	4/1975	Japan .
51-127725	11/1976	Japan .
53-63014	6/1978	Japan .
54-14231	2/1979	Japan .
56-5072	2/1981	Japan .
59-23335	2/1984	Japan .
59-109006	6/1984	Japan .
59-123832	7/1984	Japan .
60-59311	4/1985	Japan .
61-87122	5/1986	Japan .
61-273514	12/1986	Japan .

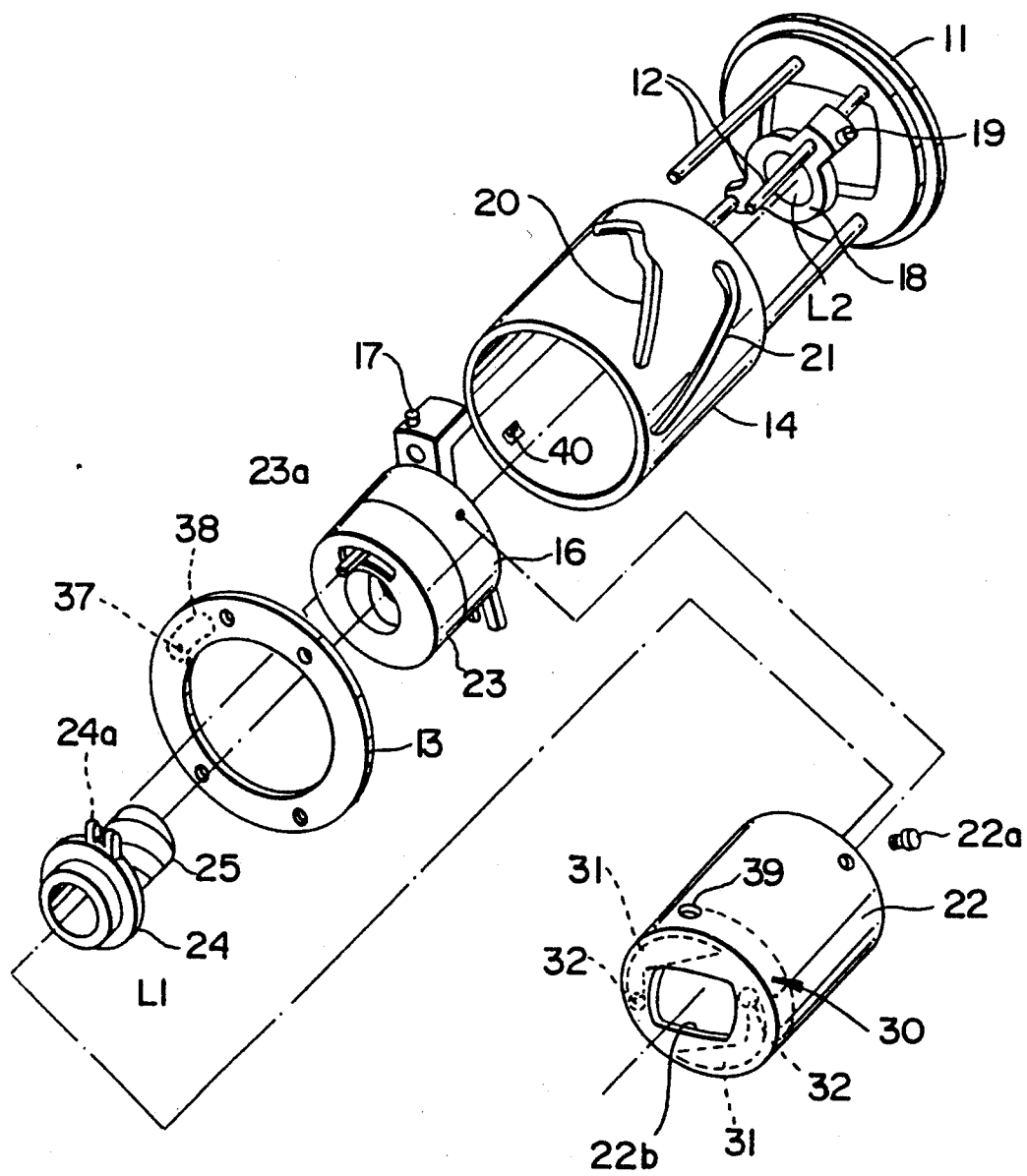

Fig- 8

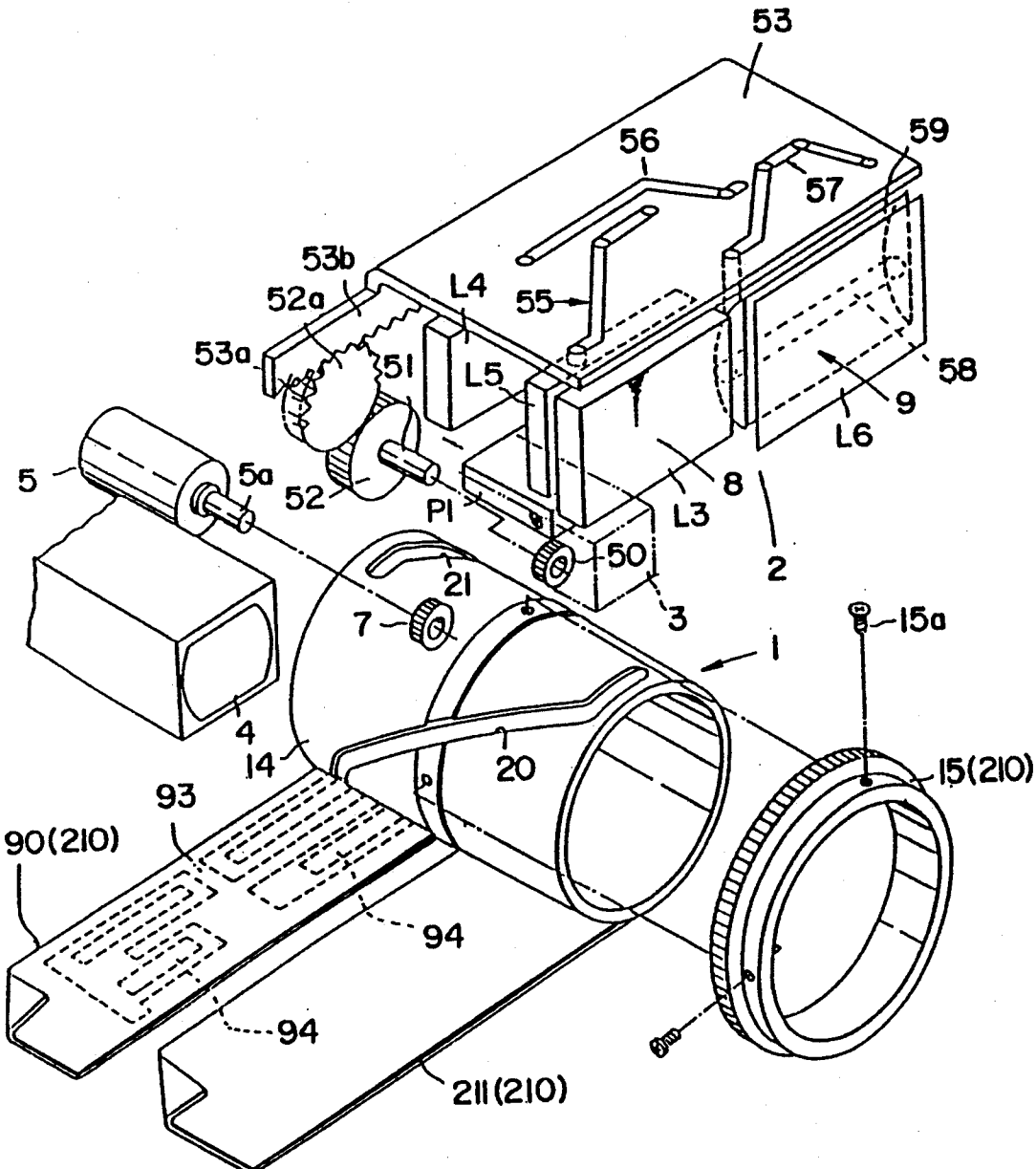

FIG - 35



US005467684A

United States Patent [19][11] **Patent Number:** **5,467,684****Sher**[45] **Date of Patent:** **Nov. 21, 1995**[54] **ROTARY PISTON DRIVING MECHANISM**[76] Inventor: **Arieh Sher**, 35 Spinoza St., Rehovot 76452, Israel[21] Appl. No.: **100,949**[22] Filed: **Aug. 3, 1993****Related U.S. Application Data**

[63] Continuation-in-part of Ser. No. 83,760, Jun. 30, 1993, Pat. No. 5,350,390, which is a continuation of Ser. No. 857,556, Mar. 25, 1992, abandoned.

[51] **Int. Cl.⁶** **F01B 3/00**[52] **U.S. Cl.** **92/31; 92/106; 74/129**[58] **Field of Search** **92/31, 32, 33, 92/106; 74/128, 129**[56] **References Cited****U.S. PATENT DOCUMENTS**

308,523	11/1884	Sergeant .	
575,970	1/1897	McCulloch .	
807,399	12/1905	Rice, Jr. .	
1,173,326	2/1916	Taylor et al. .	
1,623,411	4/1927	Hulshizer .	
2,176,300	10/1939	Fette	92/31
2,918,799	12/1959	Geyer .	
3,766,952	10/1973	Boers .	
3,911,793	10/1975	Izumi .	
3,948,502	4/1976	Waller et al. .	
3,961,559	6/1976	Teramachi .	
3,967,535	7/1976	Rozansky	92/31
4,036,309	7/1977	Petreev et al. .	
4,092,213	5/1978	Nishimura .	
4,114,517	9/1978	Teramachi .	
4,265,434	5/1981	Hamilton et al. .	
4,274,327	6/1981	Olsgaard	92/31
4,316,465	2/1982	Dotson, Jr. .	
4,324,243	4/1982	Helfgott et al. .	
4,351,516	9/1982	Ersoy et al.	92/33
4,359,109	11/1982	Truong-Cao	74/128
4,484,510	11/1984	Hirzel .	
4,508,327	4/1985	Ersoy .	
4,631,052	12/1986	Kensey .	

4,674,500	6/1987	DeSatrik .	
4,749,376	6/1988	Kensey et al. .	
4,770,174	9/1988	Luckman et al. .	
4,784,636	11/1988	Rydell .	
4,790,813	12/1988	Kensey .	
4,819,635	4/1989	Shapiro .	
4,850,957	7/1989	Summers .	
4,957,482	9/1990	Shiber .	
5,005,468	4/1991	Ulle .	
5,024,651	6/1991	Shiber .	
5,047,008	9/1991	de Juan, Jr. et al. .	

FOREIGN PATENT DOCUMENTS

2645009	10/1990	France .	
290306	9/1913	Germany .	
581933	8/1933	Germany	91/196
2344722	3/1974	Germany	92/31
2446609	4/1976	Germany	92/31
2516134	10/1976	Germany	92/33
2652228	5/1978	Germany	92/33
13081	2/1977	Japan	923/33
222095	7/1965	U.S.S.R. .	
568753	11/1977	U.S.S.R. .	
929932	5/1982	U.S.S.R. .	
717413	2/1986	U.S.S.R. .	
881099	11/1961	United Kingdom	92/33
8204293	5/1984	WIPO .	
8906517	1/1990	WIPO .	

Primary Examiner—Thomas E. Denion[57] **ABSTRACT**

A driving mechanism transforms continuous longitudinal reciprocation of a piston in a chamber into unidirectional rotation. The mechanism utilizes a closed wave-shaped groove defined in either the cylinder or the chamber and adapted to receive guiding members projecting from the other of the piston and the chamber. When the piston is forced to move longitudinally in either direction, the groove slides over the guiding members to force rotation. The apices of the wave-shaped groove are either contoured or provided with a gating structure to assure that the guide members do not backtrack but instead move in one direction through the groove.

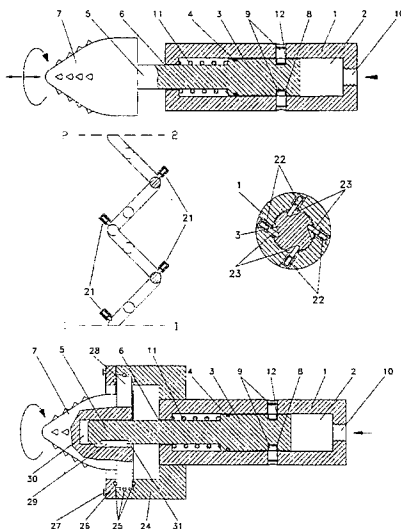
19 Claims, 6 Drawing Sheets

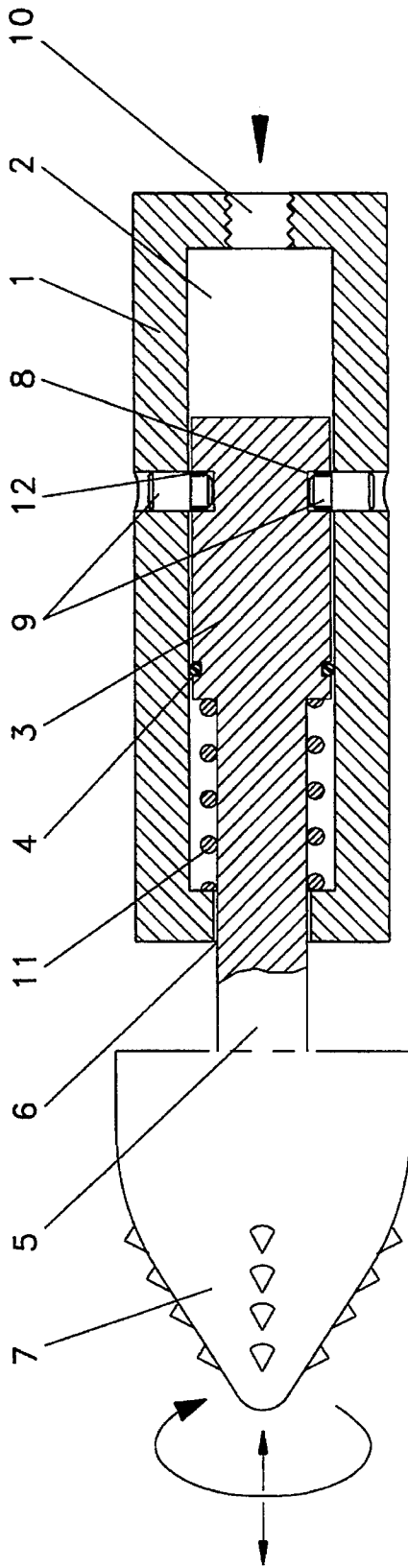

FIG. 1

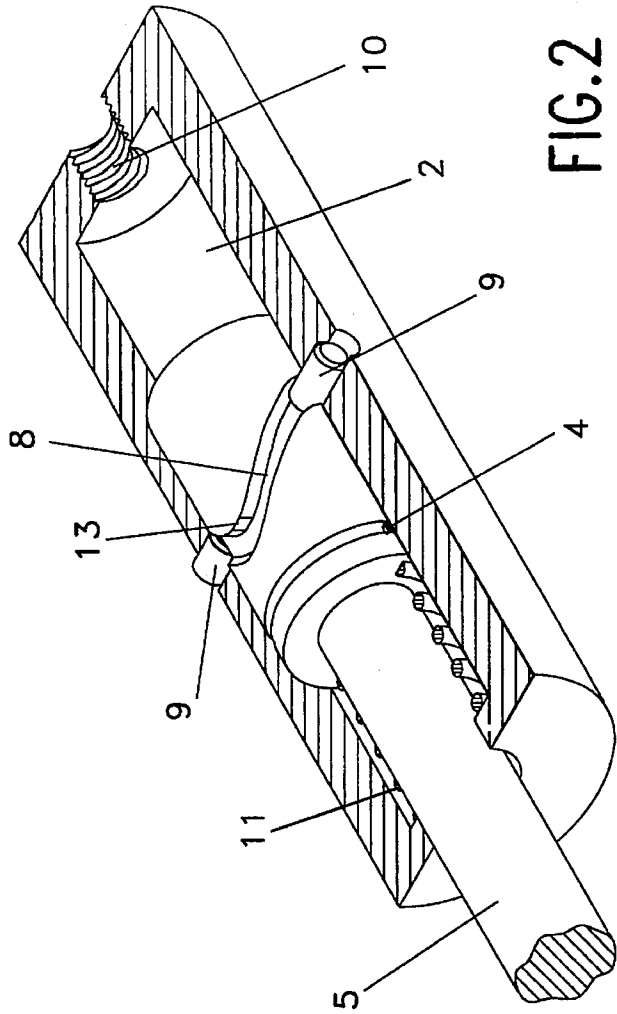

FIG. 2

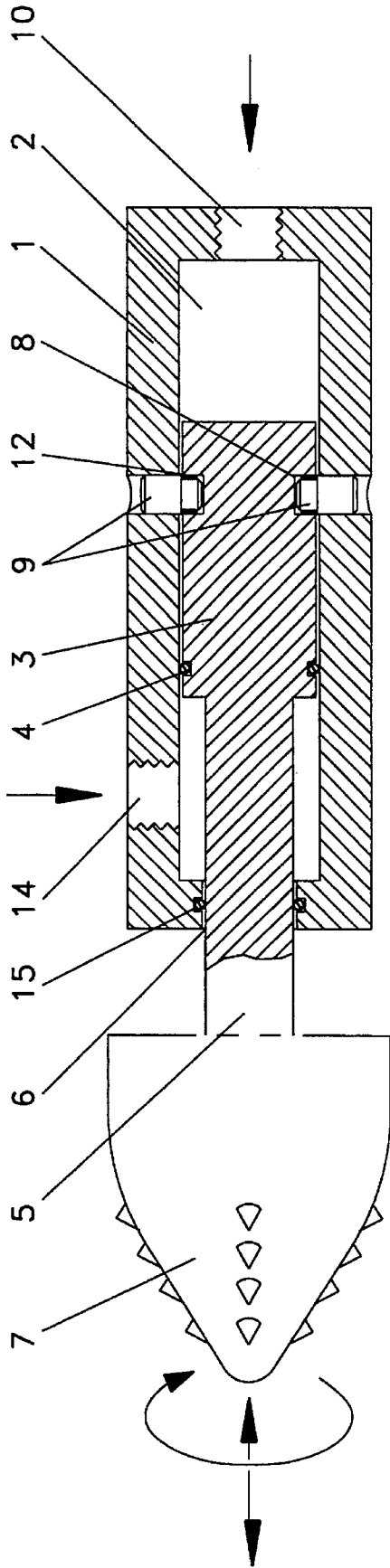

FIG. 3

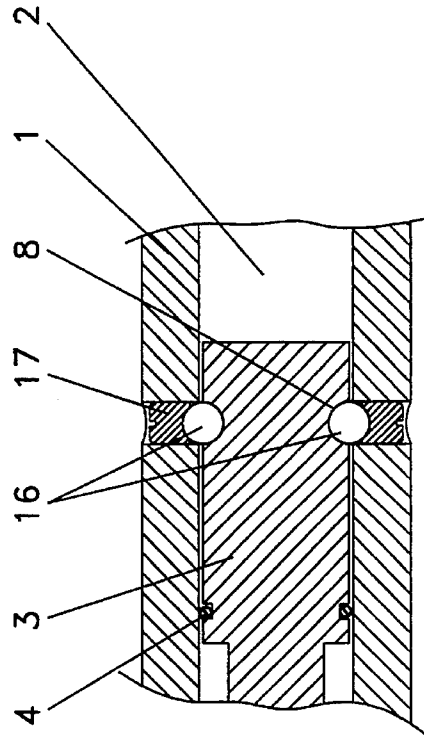

FIG. 4

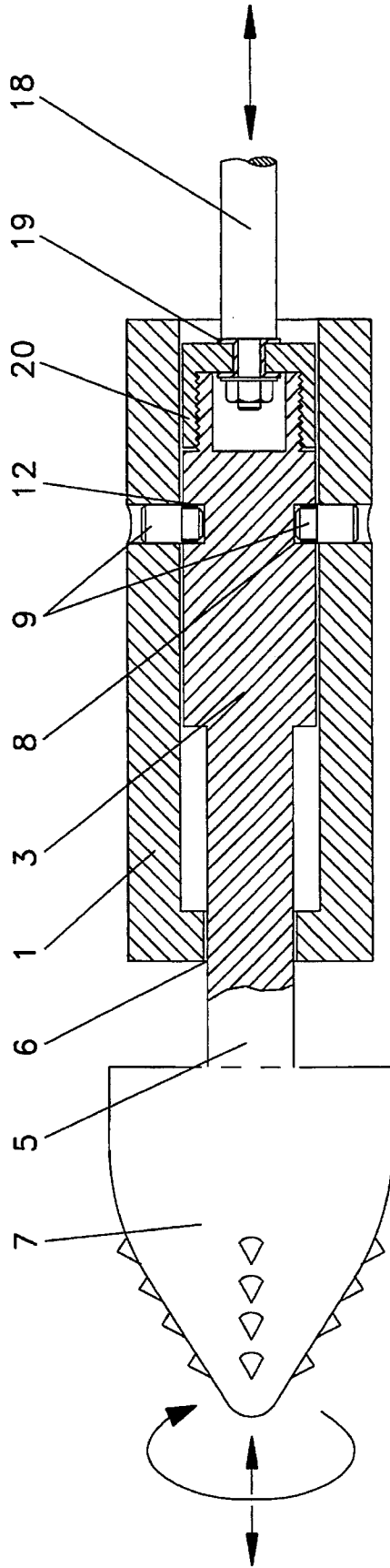

FIG. 5

Appendix D: Gear Driven Design Analysis

MATLAB Code for Analysis of Gear Design:

```
% Screw Driven Direction Reversing Crank System (SDDRC)
% Written by Stephen Scruggs
% Created July 12, 2011

% Description:
% This program is to aid in the design of the crank driven mini pump.

clear all
format compact

% Calculating Minimum Pinion Sizing
% Based off of Shigley's Inference section for spur gears, p685-687

angle = 20; % pressure angle, degrees, see p696 Table 13-1 for standards.
m = 10; % teeth ratio, NH/NP, teeth half gear/ teeth pinion
k = 1; % 1 for full depth, .8 for stub teeth
P = 96; % Diametral pitch, see p697 Table 13-2 for standard sizes, teeth/inch
NHuse = 90; % Desired number of teeth on the half gear;
Fwidth = .1; % Face width, in

RPM = 80; % revs per minute of the crank

% see www.roton.com for common sizing
% seleted 1/4 x .250 RH Hi-Lead
Pres = 10; % pressure inside cylinder, psi
SurfArea = .25*pi*2^2; % surface area of the piston face, in^2
dm = .25; % mean diameter of power screw, in
fric = .1; % friction coefficient of the screws
lead = .250; % lead of screw, in/rev

% Equation 13-11, p686
NP = ((2*k)/((1+2*m)*(sind(angle)^2)))*(m+(m^2+(1+2*m)*(sind(angle)^2))^.5);

NPold = NP; % Stores original NP for reference if you wanted to see what it is.
NP = ceil(NP); % Rounds NP up to the nearest whole tooth;

% Equation 13-12, p687
NH = ((NP^2)*(sind(angle)^2)-4*k^2)/(4*k - 2*NP*(sind(angle)^2));

NHold = NH;
NH = round(NH); % Book just rounds this number.

% Calculate allowed m (largest allowed m)
mmax = NH/NP;

% Calculate diameters of pinion and half using diametral pitch and calced
% teeth
DP = NP/P; % Diameter of pinion, inch
DPwA = DP + 2*1/P; % Diameter of pinion with addendum added p680, inch
DPwoD = DP - 2*1.25/P; % Diameter of pinion without dedendum, inch
DH = NHuse/P; % Diameter of half gear, inch
DHwA = DH + 2*1/P; % Diameter of half gear with addendum added p680, inch
DHmax = NH/P; % Max diameter of half gear, inch
```

```

DM = DH + DP; % minimum diameter of the main gear, based on geometry, inch
DMwA = DM + 2*1/P; % Diameter of main gear with addendum added p680, inch

% Calc number of revolutions of the pinion for 1 rev of main gear
% Assumption is made that half gear is exactly half a gear (bad design
% because of binding problems)
GearRatio = (DH/DP)*.5; % .5 is because there is only half a gear

% Find the forces on the powerscrew with this gear ratio
% Torque to compress cylinder is Eq 8-1 p416 (Compressing cylinder is equivalent
% to raising the load in the books terms)
Stroke = lead*GearRatio; % Max stroke of the piston with the given lead and calced gear ratio, inches
Volume = Stroke*SurfArea; % Volume displaced in a stroke, in^3
F = Pres*SurfArea;
Tcompress = F*dm*.5*((pi*fric*dm + lead)/(pi*dm - fric*lead)); % lb*in
Tcrank = Tcompress*(DM/DP); % lb*in

% Assume for now that the screw is strong enough and check tooth bending
% and contact stresses on the pinion. Use Lewis for preliminary calcs
npinion = RPM * GearRatio;
V = pi*DP*npinion/12; % pitch-line velocity, ft/min
Kv = (1200 + V)/1200; % Kv for cut or milled profile (14-4b)
% Y values are from Table 14-2
Yarray = [.245 .261 .277 .290 .296 .303 .309 .314 .322 .328 .331 .337 .346];
Tarray = [ 12 13 14 15 16 17 18 19 20 21 22 24 26];
% look up y value
Y = interp1(Tarray,Yarray,NP);
% Transmitted Load Wt is Torque to compress x pinion diameter;
Wt = Tcompress * DP; % lb
stress = (Kv*Wt*P)/(Fwidth*Y); % bending stress, psi, eqn 14-7

```

Table D-1 – Summary of MATLAB inputs and results.

Description (Variable Name)	Value
half gear diameter (DH)	.94 in
main gear diameter (DM)	1.1 in
pinion diameter (DP)	.2 in
Gear thickness (Fwidth)	.1 in
Gear ratio, pinion to half moon (GearRatio)	2.65
Stroke	.67 in
Piston area (SurfArea)	3.14 in
Pressure in cylinder (Pres)	10 psi
Torque to turn screw (Tcompress)	1.7 in*lb
Torque to turn crank (Tcrank)	10.7 in*lb
Volume per stroke (Volume)	2.1 in ³
Bending stress on teeth (stress)	960 psi (< 3000 psi allowable)

Appendix E – MATLAB Code for Analysis of Connecting Rod Design

```
% Contact Angle for Piston design
% Created October 1, 2011
% by Stephen Scruggs, and Kyle Kriete

% gamma - angle of contact force on arm, defined from the positive x axis, rads
% beta - angle of rotation of crank, rads
% L - length of arm, in
% r - radius of driver, in
% A - surface area of piston, in^2
% P - pressure inside cylinder (Assume constant), psi

clear all

L = 2; % length of arm, in
r = 1; % radius of driver, in
A = 1; % surface area of piston, in^2
P = 10; % pressure inside cylinder (constant), psi
Ff = 0; % friction force on piston o-ring, lb

beta = [4.714:.01:7.854]; % array of beta's to rotate the crank through, [start,step,final] rads

gamma = acos((r*cos(beta))/L); % array of contact force angles on arm, rads
gamma1 = pi - gamma;

Fcy = P*A + Ff; % lb
Fcx = Fcy./tan(gamma); % lb
T = Fcx.*r.*sin(beta) + Fcy.*r.*cos(beta); % torque on crank, in*lb

% now assume no torque when cranking on expansion stroke. so
length = length(T);
for i=1:length
    if T(i) >= 0
        T(i) = T(i);
    else
        T(i) = 0;
    end
end

betad = radtodeg(beta);
gamma1d = radtodeg(gamma1);

figure(1);
plot(betad,T);
xlabel('Crank rotation angle, \beta, deg');
ylabel('Torque to turn crank, T, in*lb');
```

Appendix F – FBD/MAD Diagrams and Developed Equations for Wave Driven Design

Free Body Diagram:

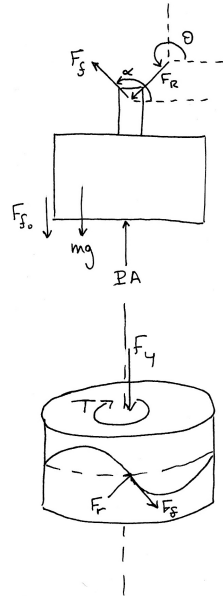

Mass Acceleration Diagram:

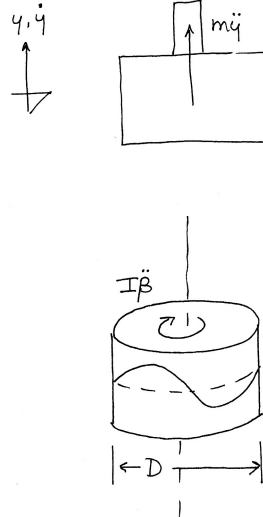

Variables Descriptions:

- P – pressure inside cylinder (psi)
- A – face area of piston (in²)
- D – diameter of driver (in)
- F_f – friction between slide rail & attachment point (lb_f)
- F_R – contact force between rail & attachment point (lb_f)
- F_o – friction force from o-ring friction (lb_f)
- T – torque on driving cylinder
- μ_r – friction coefficient between rail and attachment point

Assumptions:

- Coulomb friction
- Mass of driver & piston are small (I & m) therefore dynamic effects will be ignored

Solving the FBD/MAD equations for T yields:

$$\text{for } \ddot{y} \uparrow, \quad T = \left(\frac{D}{2}\right) \left[\frac{-PA + F_o}{\sin\theta + \mu_r \sin(\theta - \frac{\pi}{2})} \right] \left[\cos(\theta + \pi) + \mu_r \cos(\theta + \frac{\pi}{2}) \right]$$

$$\text{for } \ddot{y} \downarrow, \quad T = \left(\frac{D}{2}\right) \left[\frac{-PA - F_o}{\sin\theta - \mu_r \sin(\theta - \frac{\pi}{2})} \right] \left[\cos(\theta + \pi) - \mu_r \cos(\theta + \frac{\pi}{2}) \right]$$

where T is the torque required to turn the crank assuming dynamic effects are negligible because the mass of the piston and driver are small.

Appendix G - Development of Ideal Gas Equation for Pressure

Before the valve connecting the ball & pump opens.
(pressure in ball > pressure in cylinder)

Ideal gas law: $\frac{P_o \cancel{V_o}}{\cancel{m_o} R \cancel{T_o}} = \frac{P_n \cancel{V_n}}{\cancel{m_n} R \cancel{T_n}}$ o - original
n - now

$$P_n = \frac{P_o \cancel{V_o}}{\cancel{V_n}} \quad - \textcircled{I}$$

$$\cancel{V_o} = 2A \cdot A_s \quad - \textcircled{II} \quad \text{where } A \text{ is amplitude of wave}$$

A_s is area of piston

$$\cancel{V_n} = A_s \cdot A \left[1 + \sin\left(\frac{2\pi}{T} x\right) \right] \quad - \textcircled{III}$$

where T is the period of wave
x is position along wave

sub \textcircled{II} & \textcircled{III} into \textcircled{I}

$$P_n = \frac{P_o 2A \cdot A_s}{A_s \cdot A \left[1 + \sin\left(\frac{2\pi}{T} x\right) \right]}$$

$$P_n = \frac{2P_o}{1 + \sin\left(\frac{2\pi}{T} x\right)}$$

description of pressure with valve closed. Note: use absolute pressures.

After valve opens, the ball & pump will be at the same pressure. Ball volume stays constant while pump volume decreases.

$$P_n = \frac{P_o \cancel{V_{b+o}}}{\cancel{V_{bn}}}$$

description of pressure with valve open

where P_o = Pressure @ valve opening

$$\cancel{V_{b+o}} = \cancel{V_b} + A_s A \left[1 + \sin\left(\frac{2\pi}{T} x_o\right) \right]$$

$$\cancel{V_{bn}} = \cancel{V_b} + A_s A \left[1 + \sin\left(\frac{2\pi}{T} x\right) \right]$$

x_o = position @ valve open

$\cancel{V_b}$ = volume of ball

Appendix H – MATLAB Code for Analysis of Wave Driven Design

```
% Pump Parameters File
%
% Created by Stephen Scruggs on October 11, 2011
%
% This file contains the parameters loaded by the simulink model,
% "DynamicModel.mdl" before the simulink file is run. All variables
% in this file are global variable used by other functions.

clear all

global A T d Pa Pbi Vb Area RPM mu overlay mass I Fo dV

A = .25; % Amplitude of wave, inches
d = 1; % diameter of driver, inches
T = pi*d; % period of wave, inches
%Area = pi*.25*(1+(7/8))^2; % area of piston face, in^2
%Area = pi*.25*(2+(3/16))^2; % area of piston face, in^2
Area = pi*.25*(2)^2; % area of piston face, in^2
dV = Area*.1; % extra volume in piston even when cylinde is fully compressed, in^3

% Fluids Info
Pa = 14.7; % atmospheric pressure, psia
Pbi = 0; % initial inflation pressure of ball, psig
Vb = 330; % volume of the ball, in^3

mass = 0.0010878; % mass of piston, slugs
I = 0.02; % inertia of crank, lb*in^2

mass = mass/12; % slinches
I = I/386.4; % inertia of crank, lb*in*sec^2

mu = .15; % friction coefficient between slider and track, unitless
Fo = 2; % dynamic friction force caused by the o-ring, lb
    % see the Parker O-ring handbook p113-115 to calculate this

overlay = 10;

% Useful Reference Data:
%
%
% Ball   | Pressure (psig) | Volume (in^3)
% -----|-----|-----
% Football | 12.5-13.5   | 230
% Soccerball| 9-15       | 330-350
% Basketball| 7.5-8.5    | 410-430
% Volleyball| 2.5-4      | 320
% -----|-----|-----
% Avg    | 8.5        | 330

function y = wavepath(x)

% wavepath function
%
```

```

% Created by Stephen Scruggs on October 11, 2011
%
% This function defines the path of the wave. For any given input, x
% there must be only one output. The only variables that are fixed at the
% input x and the output y. The user may define the function in any manner.
%
% A is amplitude of slide wave, inches
% T is period of slide wave, inches
% x is position along slide, inches
% y is the vertical position (y=0 is fully compressed), inches

```

```

global A T

```

```

x = x - T*floor(x/T); % find the position within this cycle of the wave
percent = .75; % percent of wave on the compression stroke

```

```

if x <= (percent*T)
    T_e = (percent*T)*2;
    x = x;
    phi = 0;
else
    T_e = ((1-percent)*T)*2;
    x = x - (percent*T);
    phi = pi;

```

```

end

```

```

w = 2*pi/T_e;

```

```

y = A*cos(w*x + phi);

```

```

end

```

```

% PostSimulink Dynamic Model

```

```

%

```

```

% Created by Stephen Scruggs on October 11, 2011

```

```

%

```

```

% This file is called by the simulink model, "DynamicModel.mdl" after
% it completes its simulation. This file uses the information passed by
% the array, simout, to finish the pump calculations. The main output of
% this program is the torque required to turn the crank as a function of
% time.

```

```

%

```

```

% The input array to this function comes from running the simulink model

```

```

% DynamicModel.mdl, the input array is the following:

```

```

%

```

```

% simout = [t,x,y,yd,ydd,beta,betad,betadd]

```

```

%

```

```

% 1- t is time, sec

```

```

% 2- x is position, in

```

```

% 3- y is vertical position (y=0 is fully compressed), in

```

```

% 4- yd is vertical velocity (yd+ is up), in/sec

```

```

% 5- ydd is vertical acceleration (ydd+ is up), in/sec^2

```

```

% 6- beta is angular position of crank, rev

```

```

% 7- betad is angular velocity of crank, rev/sec

```

```

% 8- betadd is angular acceleration of crank, rev/sec^2

```

```

%

```

```

% master = [t,x,y,yd,ydd,beta,betad,betadd,P,Pball,T,Tf]

```

```

%
% 9- P is pressure inside the cylinder, psia
% 10- Pball is pressure inside the ball, psia
% 11- T is torque to turn the crank without friction, in*lb
% 12- T is torque to turn the crank with friction, in*lb

global A Area T d Pa Vb w Vb RPM mu Pv xv valve step simout Pbi overlay mass I maxy Fo

% relocate simout array into the master array
master = zeros(length(simout),12);
master(:,1) = simout(:,1); % t, sec
master(:,2) = simout(:,2); % x, in
master(:,3) = simout(:,3); % y, in
master(:,4) = simout(:,4); % yd, in/sec
master(:,5) = simout(:,5); % ydd, in/sec^2
master(:,6) = simout(:,6); % beta, rev
master(:,7) = simout(:,7); % betad, rev/sec
master(:,8) = simout(:,8); % betadd, rev/sec^2

w = 2*pi/T; % period
maxfind = max(master,[],1); % finds the maximum position on the wave, in
maxy = maxfind(3); % gets max position for vector of maxes

% conversions to psia
Pbi = Pbi + Pa;

Pv = 0; % initialize valve opening pressure
xv = 0; % initialize valve opening position
valve = 0; % close valve
Fr = zeros(1,length(master)); % initialize force array

master(1,10) = Pbi; % set initial ball pressure
master(1,9) = Pa; % set initial pump pressure

% without friction run
for i = 2:length(master)
    theta = contactangle(master(i,2));
    Press = pressurefunc(master(i,:),master(i-1,:)); % find current pressure
    master(i,9) = Press(1); % pressure inside the cylinder, psia
    master(i,10) = Press(2); % pressure inside the ball, psia

    Fr(i) = ((-(master(i,9)-Pa)*Area)+(mass*master(i,5)))/(sin(theta)); % magnitude of Fr
    master(i,11) = Fr(i)*d*(cos(theta + pi))/2; % torque to turn crank, in*lb
end

Fr2 = zeros(1,length(master)); % initialize force array

% pressures are the same for both runs. pressure has already been written
% to the array.

% with friction run
for i = 2:length(master)
    theta = contactangle(master(i,2));

    if master(i,4) < 0 % if the cylinder is in compression stroke
        Fr2(i) = ((-(master(i,9)-Pa)*Area) - Fo + (mass*master(i,5)))/(sin(theta) + mu*sin(theta - .5*pi));
        master(i,12) = (Fr2(i)*d*(cos(theta + pi) + mu*cos(theta + .5*pi))/(2))+(I*master(i,8)*2*pi);
    else % if the cylinder is in the expansion stroke
        Fr2(i) = ((-(master(i,9)-Pa)*Area) + Fo + (mass*master(i,5)))/(sin(theta) - mu*sin(theta - .5*pi));
    end
end

```



```

        master(i,12) = (Fr2(i)*d*(cos(theta + pi) - mu*cos(theta + .5*pi))/(2))+(I*master(i,8)*2*pi);
    end
end

% Output Plots
plot(master(:,1),master(:,11),master(:,1),master(:,12));
xlabel('Time, t (sec)');
ylabel('Torque, T (in*lb)');
hold on
plot(master(:,1),master(:,3),'--black');
Pballg = master(:,10) - Pa;
plot(master(:,1),Pballg);
legend('Torque Curve w/o Friction','Torque Curve w/ Friction','Track Overlay','Ball Pressure, psig');
hold off

function angle = contactangle(x)

% INPUT is position x, inches
%
% contactangle function
%
% Created by Stephen Scruggs on October 11, 2011
%
% This program finds the angle perpendicular to a path given in the
% function file "wavepath". It does this by taking the negative reciprocal
% of the slope of "wavepath" and then taking the arctan of result.
%

dx = .001; % tiny derivative slice

x1 = wavepath(x+dx);
x2 = wavepath(x-dx);
dfdx = (x1-x2)/(2*dx); % approximate derivative around x

% atan of negative inverse of slope is the line perpendicular to the wave
% path. if statement corrects solution to account for compression and
% expansion strokes.

if dfdx < 0 % compression stroke
    angle = atan(-1/dfdx) - pi;
else % expansion stroke
    angle = atan(-1/dfdx) + pi;
end

% OUTPUT is in radians

end

function Pressure = pressurefunc(now,past)

% Sidewinder Pressure Program
%
% Created by Stephen Scruggs on October 11, 2011
%
% This program calculates the pressure inside the cylinder and ball as a
% function of the changing volume within the cylinder. The fluid is
% assumed to behave as an ideal gas. (PV=nRT)
%
```

```

% Pball is the pressure inside the ball, psia
% Ppump is the pressure insdie the pump, psia
% y is the vertical position of the piston (y=0 is fully compressed), in
% yd is the velocity of the piston (yd+ is up), in/sec
% Area is the piston area, in^2
% Pa is atmospheric pressure, psia
% Vb is the volume of the ball, in^3
% Pv is the pressure at valve opening, psia
% xv is the position at valve opening, in
% dV is the extra volume in the piston even when fully compressed, in^3
% valve is state of valve, (0=open,1=closed)

global Area Pa Vb Pv xv valve maxy dV

Pball = past(1,10);
Ppump = past(1,9);
y = now(1,3);
yd = now(1,4);
x = now(1,2);

Pbn = Pball;
Pn = Ppump;

if(Pbn < Pn) && (valve ~= 1)% if pressure in ball is greater than in cylinder (valve closed)
    valve = 1; % close valve
    Pv = Pbn; % reset valve opening parameters
    xv = x;
end

if(yd < 0) % if the piston is in a copression stoke
    if valve == 0 % if the valve is closed
        Vo = maxy*Area + dV; % fully open volume of cylinder, in^3
        Vn = wavepath(x)*Area + dV; % current volume in cylinder, in^3
        Pn = Pa*Vo/Vn; % current pressure in the cylinder, psia
    elseif valve == 1 % if the valve is open
        Vbo = Vb + Area*wavepath(xv) + dV; % volume of ball and cylinder at valve open, in^3
        Vbn = Vb + Area*wavepath(x) + dV; % volume of ball and cylinder now, in^3
        Pn = Pv*Vbo/Vbn; % pressure inside cylinder and ball, psia
    end
else % if the piston is in expansion stroke
    Pn = Pa; % pressure inside cylinder, psia
    valve = 0; % close the valve
    Pv = 0; % reset valve opening parameters
    xv = 0;
end

Pressure(1) = Pn; % return pressure inside the pump, psia
if valve == 1 % if the valve was open
    Pressure(2) = Pn; % pressure inside ball equals pressure inside cylinder
else % if valve was closed
    Pressure(2) = Pball; % ball pressure remains unchanged
end

end % end function

```

Appendix I – Simulink Model for Analysis of Wave Driven Design

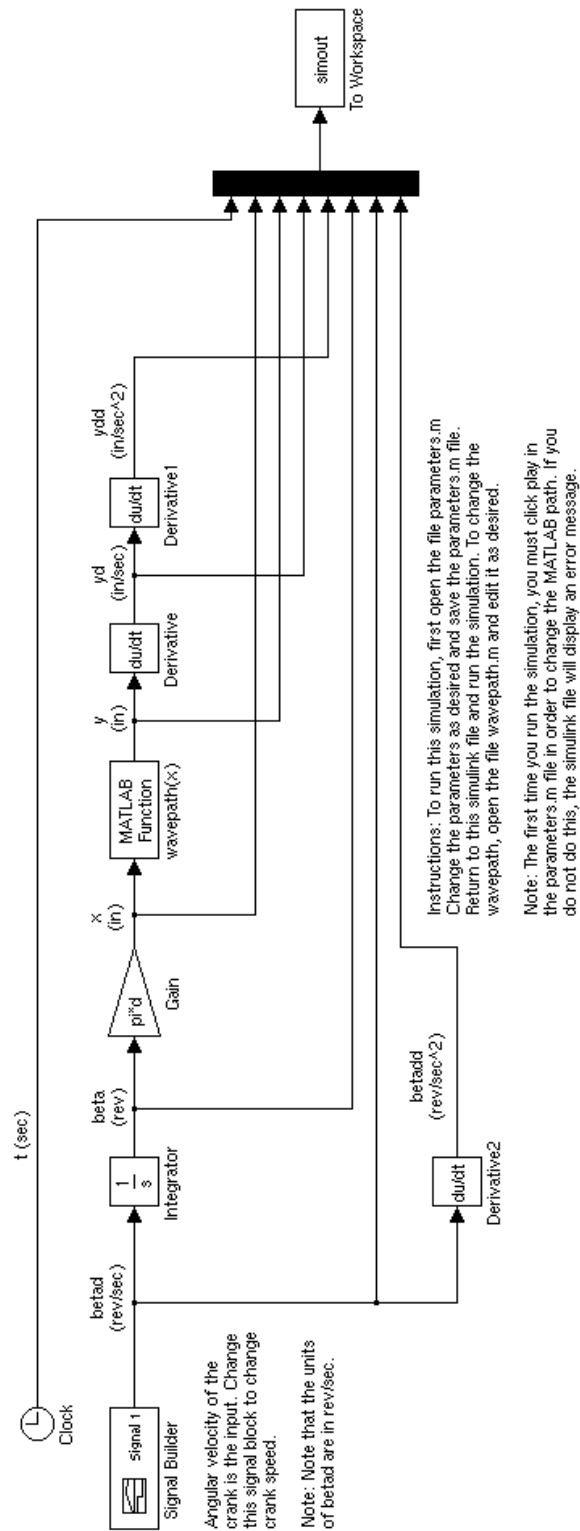

Appendix J – Output Figures from MATLAB Wave Design Simulation

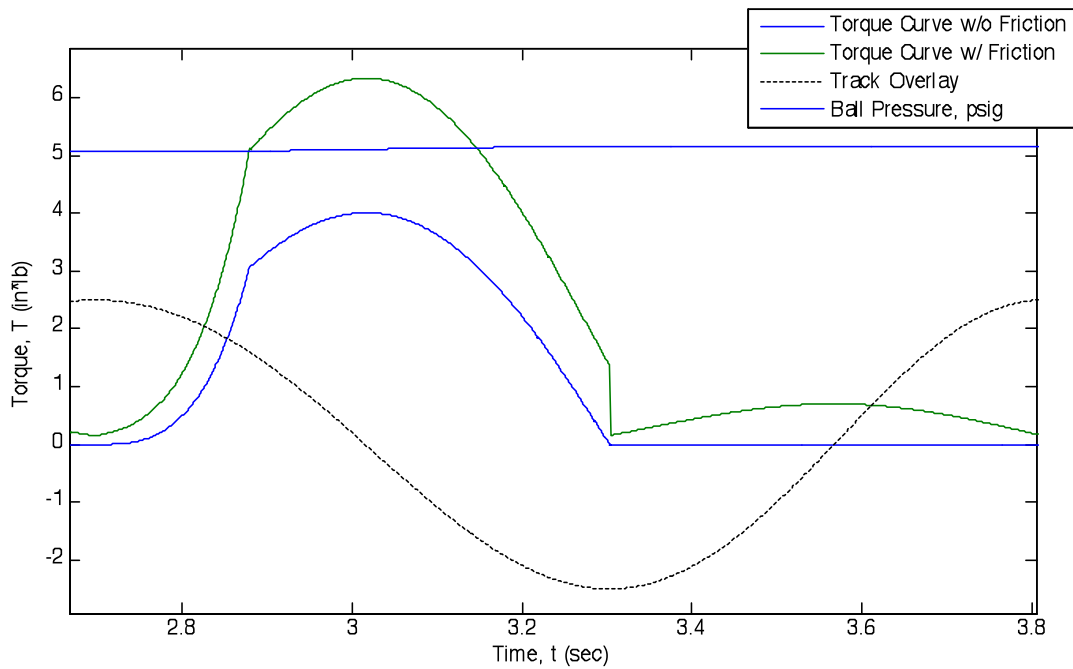

Figure J-1 – Unmodified driver wave acting against a ball pressure of 5 psi.

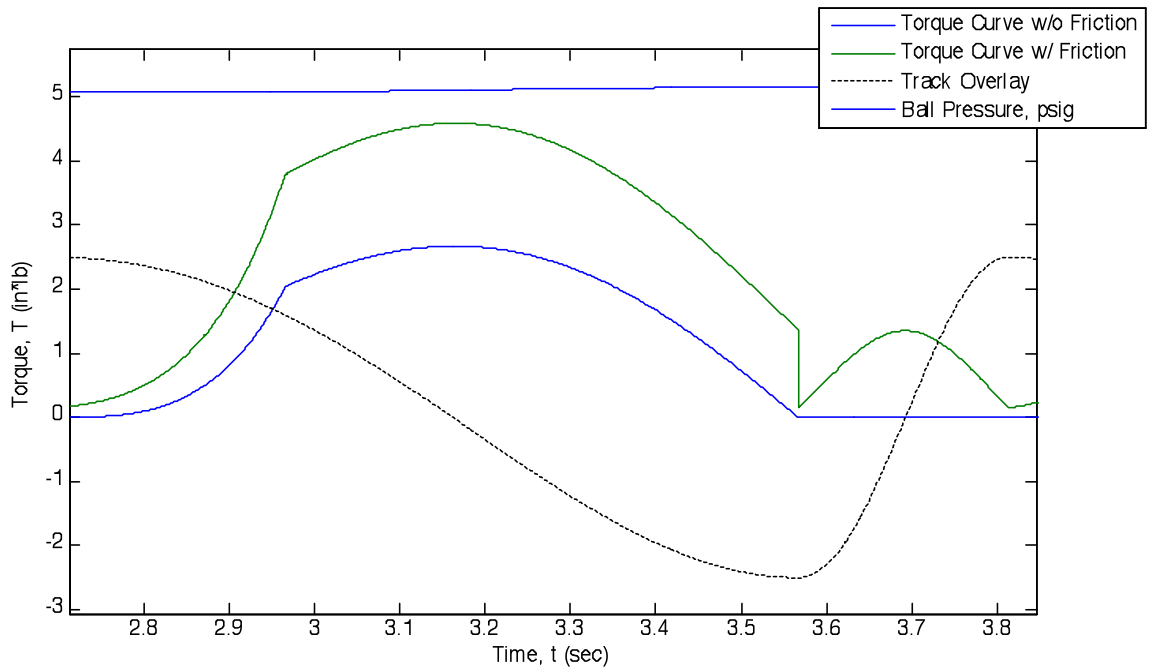

Figure J-2 – Modified driver wave with 75% of the stroke in the compression stage. Same conditions as in figure J-1, with a 30% reduction in required input torque.

Appendix K – Spring Aided Design Analysis

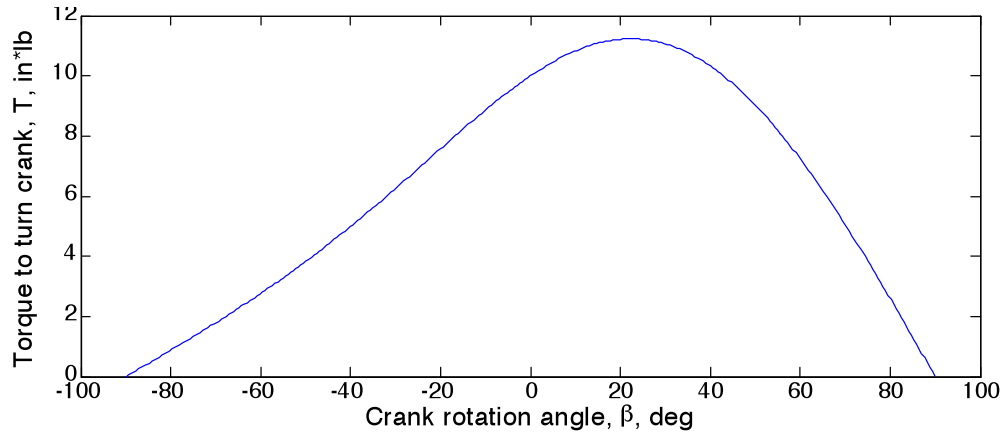

Figure K-1 – Plot of crank angle vs. input torque.

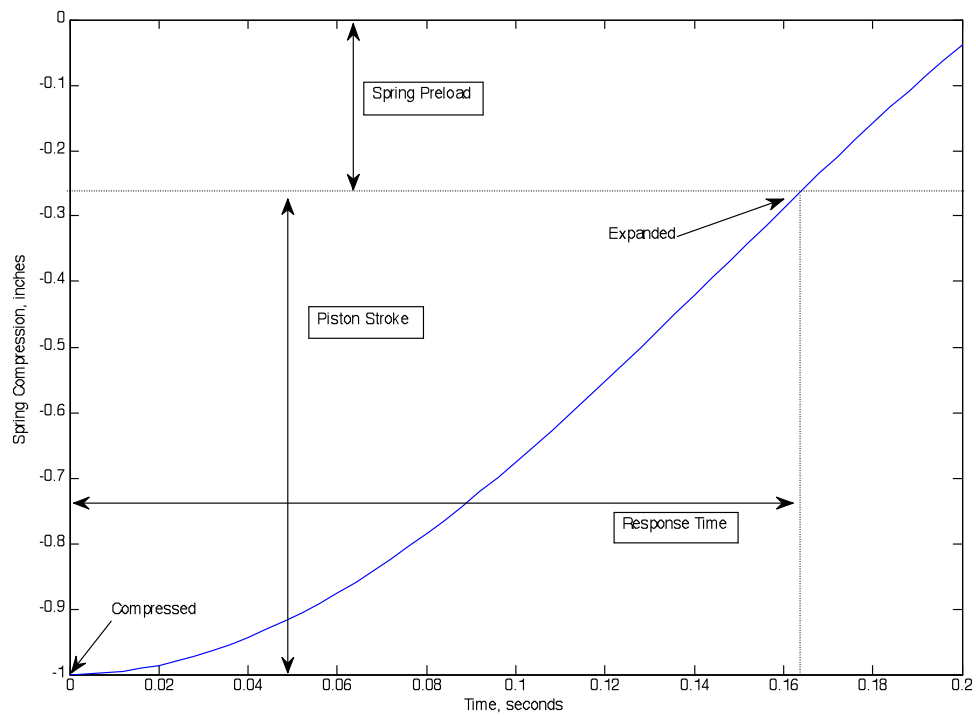

Figure K-2 – Spring response graph annotated with important values.

Table K-1 – Comparison charts for varying preloads and spring stiffness’s. Response times are given in seconds. Spring force is given in pounds.

Response Time as Function of Spring Constant and Preload

		Preload (in)					
		0.25	0.5	0.75	1	1.25	1.5
K (lbf/in)	1	0.2675	0.222	0.2183	0.2157	0.1737	0.1722
	1.5	0.2183	0.2147	0.1722	0.1705	0.1658	0.1607
	2	0.2137	0.171	0.1658	0.1592	0.1543	0.1505
	2.5	0.171	0.164	0.1566	0.1514	0.1075	0.1044
	3	0.1658	0.1566	0.1505	0.1062	0.1029	0.1004
	3.5	0.1592	0.1514	0.1062	0.1024	0.0996	0.0974
	4	0.1543	0.1475	0.1029	0.0996	0.0972	0.0953

Force on Piston as Function of Spring Constant and Preload

		Preload (in)					
		0.25	0.5	0.75	1	1.25	1.5
K (lbf/in)	1	1	1.25	1.5	1.75	2	2.25
	1.5	1.5	1.875	2.25	2.625	3	3.375
	2	2	2.5	3	3.5	4	4.5
	2.5	2.5	3.125	3.75	4.375	5	5.625
	3	3	3.75	4.5	5.25	6	6.75
	3.5	3.5	4.375	5.25	6.125	7	7.875
	4	4	5	6	7	8	9

Appendix L - Crank Torque Calculations

CRANK TORQUE CALCULATIONS

Lower Limit: weight = 1.3 lbs.

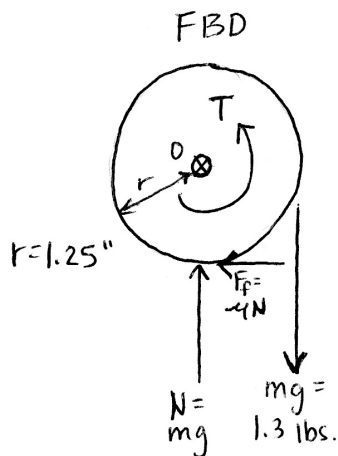

Estimate $\mu = 0.4$

$$+\uparrow \sum F_y = 0 \Rightarrow N = mg = 1.3 \text{ lbs.}$$

$$\curvearrowright \sum M_o = 0 \Rightarrow T - F_f(r) - mg(r) = 0$$

$$\Rightarrow T = \mu mg(r) + mg(r)$$

$$\Rightarrow T = mgr(\mu + 1)$$

$$\Rightarrow T = (1.3 \text{ lbs})(1.25 \text{ in.})(0.4 + 1)$$

$$\Rightarrow \boxed{T_{\text{Low}} = 2.28 \text{ in-lbs.}}$$

Upper Limit: weight = 2 lbs.

using same FBD with $mg = 2 \text{ lbs.}$:

$$T = mgr(\mu + 1)$$

$$\Rightarrow T = (2 \text{ lbs.})(1.25 \text{ in.})(0.4 + 1)$$

$$\Rightarrow \boxed{T_{\text{High}} = 3.5 \text{ in-lbs}}$$

Appendix M - Friction Test Calculations

FRICTION INCLINE TEST CALCULATION

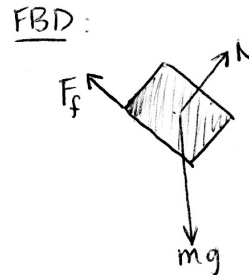
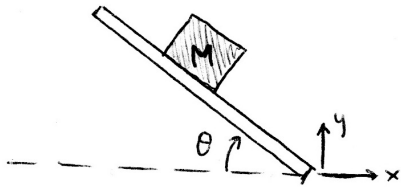

At point right before motion begins:

$$\begin{aligned} \rightarrow \sum \bar{F}_x &= -(F_f)_x + N_x = 0 \\ &\rightarrow -\mu N \cos \theta + N \sin \theta = 0 \\ &\rightarrow N \sin \theta = \mu N \cos \theta \\ &\rightarrow \mu = \frac{\sin \theta}{\cos \theta} = \tan \theta \end{aligned}$$

For:

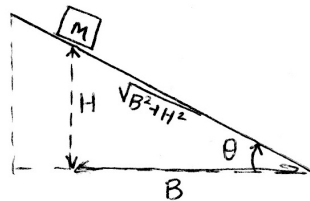

$$\mu = \tan \theta = \frac{H}{B}$$

In our case, $H = 4.5''$ and $\sqrt{B^2 + H^2} = 30.5''$

$$\begin{aligned} \rightarrow B^2 + (4.5'')^2 &= (30.5'')^2 \\ \rightarrow B &= 30.17'' \end{aligned}$$

$$\mu = \frac{H}{B} = \frac{4.5''}{30.17''}$$

$$\mu = 0.149$$

Appendix N - Beam Bending Calculation

BENDING CALCULATIONS FOR BLANK

Assume: Part will break at middle of connective piece

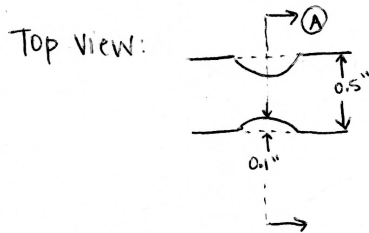

section (A):

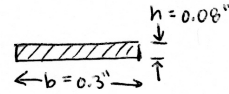

$$I = \frac{bh^3}{12} = \frac{(0.3'')(0.08'')^3}{12} = 1.28 \times 10^{-5} \text{ in}^4$$

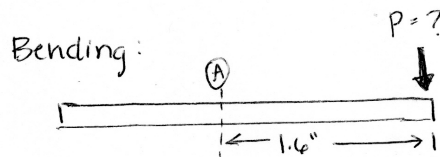

note: "P" is located at center of smaller disk which overhangs off table.

$$\sigma_b = \frac{Mc}{I} = \frac{P(1.6 \text{ in})(0.04 \text{ in})}{1.28 \times 10^{-5} \text{ in}^4} = 5000 P$$

bending stress, $\sigma_{\text{bend}} = 5000 P$

$\sigma_{\text{all}} = 5500 \text{ psi}$ for rapid prototyper's material

$$\sigma_{\text{all}} = 5000 P_{\text{all}}$$

$$5500 = 5000 P_{\text{all}}$$

$$P_{\text{all}} = 1.1 \text{ lbs}$$

Since the part is only estimated to hold 1.1 lbs before yielding, we used a thickness of $h = 0.1''$ instead:

$$\text{now } I = \frac{bh^3}{12} = \frac{(0.3 \text{ in})(0.1 \text{ in})^3}{12} = 2.5 \times 10^{-5} \text{ in}^4$$

$$\sigma_b = \frac{P(1.6 \text{ in})(0.04 \text{ in})}{2.5 \times 10^{-5} \text{ in}^4}$$

$$\sigma_b = 2560 P$$

$$P_{\text{all}} = \frac{5500 \text{ lbs}}{2560}$$

$$P_{\text{all}} = 2.15 \text{ lbs}$$

← increasing thickness to 0.1" increased allowable force to 2.15 lbs.

Stress Analysis on Pegs for Design #2:

Without step:

- Bending more critical than shear

• Max bending stress at A (tension) and B (compression)

$$\sigma_{\max} = \frac{Mc}{I} \quad \text{where } c = \frac{D}{2} = \frac{0.2}{2} = 0.1''$$

$$= \frac{(7.5 \text{ lb})(0.25 \text{ in.})(0.1 \text{ in.})}{\frac{\pi}{64} (0.2 \text{ in.})^4}$$

$$= 2387 \text{ psi}$$

$$\sigma_{\text{mat}} = 3000 \text{ psi}$$

$$SF = \frac{\sigma_{\text{mat}}}{\sigma_{\max}} = \frac{3000 \text{ psi}}{2387 \text{ psi}} = 1.25$$

Note: This safety factor is insufficient.

If force is increased to 10 lb, SF drops to < 1 and peg will break!

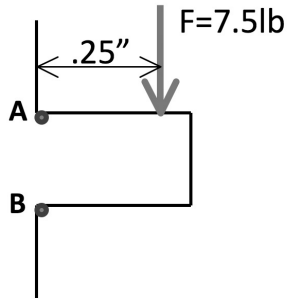

With step:

- Reduced moment arm

$$\sigma_{\max} = \frac{Mc}{I} = \frac{(7.5 \text{ lb})(0.15 \text{ in.})(0.1 \text{ in.})}{\frac{\pi}{64} (0.2 \text{ in.})^4}$$

$$= 1432 \text{ psi}$$

$$SF = \frac{\sigma_{\text{mat}}}{\sigma_{\max}} = \frac{3000 \text{ psi}}{1432 \text{ psi}} = 2.09$$

Note: This safety factor is > 2 and is sufficient.

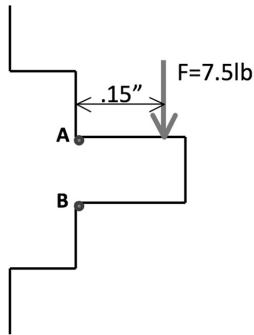

Appendix O - X-ring Compression Test

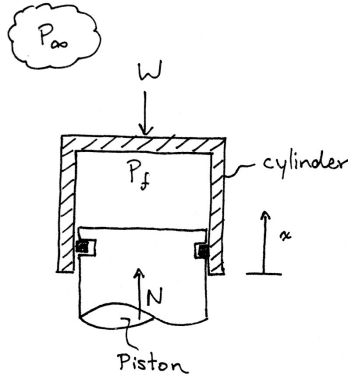

Figure _-1 – Apparatus diagram showing forces, pressures and coordinate system of the test.

Ideal gas law was used to develop the following relationship between the displacement of the cylinder and the pressure inside the cylinder.

$$P_i V_i = P_f V_f$$

where P_i = initial pressure (psia)
 P_f = final pressure (psia)
 V_i = initial volume (in³)
 V_f = final volume (in³)

$$P_f = P_i \frac{V_i}{V_f}$$

$$P_{f\ gauge} + P_\infty = P_\infty \frac{V_i}{V_f}$$

where $P_f = P_{f\ gauge} + P_\infty$ and $P_i = P_\infty$

where $P_{f\ gauge}$ = final pressure (psig)
 P_∞ = atmospheric pressure (psia)

$$P_{f\ gauge} = P_\infty \left(\frac{V_i}{V_f} - 1 \right) \quad (\text{eqn _1})$$

where for the cylinder on the pump, the volumes can be described by:

$$V_i = \frac{\pi}{4} d^2 B \quad \text{and} \quad V_f = \frac{\pi}{4} d^2 (B - \Delta x)$$

where d = inner diam. of the cylinder (in)
 B = bore of the cylinder (in)
 Δx = change in height of the cylinder (in)

$$\frac{V_i}{V_f} = \frac{\frac{\pi}{4} d^2 B}{\frac{\pi}{4} d^2 (B - \Delta x)} = \frac{B}{B - \Delta x}$$

substituting the above equations into equation _-1 yields:

$$P_{f\ gauge} = P_\infty \left(\frac{B}{B - \Delta x} - 1 \right) = P_\infty \left(\frac{\Delta x}{B - \Delta x} \right) \quad (\text{equ _2})$$

Appendix P – Cost Estimation

Cost Estimation for 75,000 Units

Variables	Case	Cylinder	Case Top	Driver	Crank	Peg Stand	Gland
Resin Price (\$/lb)	0.75	0.75	0.75	0.75	0.75	0.75	0.75
Part Weight (g)	31.02	7.04	7.04	8.23	6.68	1.19	2.27
Material Yield (%)	0.95	0.95	0.95	0.95	0.95	0.95	0.95
Annual Production (parts)	75,000	75,000	75,000	75,000	75,000	150,000	75,000
Labor (\$/h)	6.50	6.50	6.50	6.50	6.50	6.50	6.50
Cycle Time (s)	30.00	20.00	20.00	18.00	20.00	18.00	18.00
Machine Utility (%)	0.85	0.85	0.85	0.85	0.85	0.85	0.85
Process Yield (%)	0.95	0.95	0.95	0.95	0.95	0.95	0.95
Number of Cavities	4.00	4.00	4.00	6.00	6.00	8.00	4.00
Hours/Year Machine is Available	6,000	6,000	6,000	6,000	6,000	6,000	6,000
Molding Machine Cost (\$)	110,000	110,000	110,000	110,000	110,000	110,000	110,000
Direct Investment, DI (\$)	165,000	165,000	165,000	165,000	165,000	165,000	165,000
Allocated Direct Invest, ADI (\$/h)	27.50	27.50	27.50	27.50	27.50	27.50	27.50
Overhead (\$/h)	14.56	14.56	14.56	14.56	14.56	14.56	14.56
Maintenance (\$/h)	2.75	2.75	2.75	2.75	2.75	2.75	2.75
Taxes&Depreciation (\$/h)	3.30	3.30	3.30	3.30	3.30	3.30	3.30
Utilities (\$/h)	2.75	2.75	2.75	2.75	2.75	2.75	2.75
Selling Expenses (%)	0.10	0.10	0.10	0.10	0.10	0.10	0.10
Return on Investment (ROI)	0.20	0.20	0.20	0.20	0.20	0.20	0.20
Mold Cost (\$)	12,000	7,500	7,500	5,000	5,000	5,000	10,000
Mold Armotization (\$/1000)	160.00	100.00	100.00	66.67	66.67	33.33	133.33
K	29.86	29.86	29.86	29.86	29.86	29.86	29.86
Hourly Machine Rate (\$/h)	46.07	46.07	46.07	46.07	46.07	46.07	46.07
Capacity/Year/Mold	2,325,600	3,488,400	3,488,400	5,814,000	5,232,600	7,752,000	3,876,000
Pounds/Year/Mold	5,394	1,224	1,224	1,431	1,162	414	395
Material Cost (\$/1000)	53.94	12.24	12.24	14.31	11.62	2.07	3.95
Processing Cost (\$/1000)	22.71	15.14	15.14	9.08	10.09	6.81	13.62
Mill Cost (\$/1000)	76.65	27.38	27.38	23.39	21.71	8.88	17.57
Cost of Sales (\$/1000)	86.58	31.63	31.63	26.64	24.89	10.45	20.69
Profit on Fixed Investment (\$/1000)	21.28	14.19	14.19	8.51	9.46	6.39	12.77
Profit on Working Capital (\$/1000)	5.11	1.83	1.83	1.56	1.45	0.59	1.17
Total Profit (\$/1000)	26.39	16.02	16.02	10.07	10.91	6.98	13.94
Selling Price (\$/1000)	112.98	47.65	47.65	36.72	35.79	17.43	34.63
User's Price (\$/1000)	272.98	147.65	147.65	103.38	102.46	50.76	167.97

Total Manufacturer	\$992.84
2 Valves (\$/1000)	\$100.00
Xring (\$/1000)	\$70.00
Assembly Cost (\$/1000)	\$70.00
Total Cost (\$/1)	\$1.23
Distribution Sales Price (\$/1)	\$4.93
Capital Cost (\$)	\$92,463.18

Mold Cost Estimate Factors							
Total Part Weights (g)	Factor A	Geometry Difficulty	Factor B	Number of Cavities	Factor C	Cavities Projected Area (in ²)	Factor D
<29	1	Simple	1	1	1	4	1
30-119	3	Moderate	3	2	2	8	3
120-239	5			4	3	16	5
240-479	8	Complex	5	8	4	32	8
>480	10			12	5	64	10
				16	6	128	12
				24	7	250	14
				32	8		
				64	9		
Factor A: Describes the full shot size or total weight of the parts							
Factor B: Describes the mold configuration and characteristics							
Factor C: Based on the number of cavities in the mold							
Factor D: Based on the total projected area of the cavities							
Total Mold Cost Factors = A + B + C + D							

Mold Cost / Total Mold Factors	
Mold Cost Factors	Mold Cost Dollars (\$)
4-5	<5,000
6-8	5,000-10,000
9-11	10,000-20,000
12-14	20,000-30,000
15-17	30,000-40,000
18-20	40,000-50,000
21-23	50,000-75,000
24-Up	75,000-Up

Appendix Q – Technical Drawings

See the following pages.

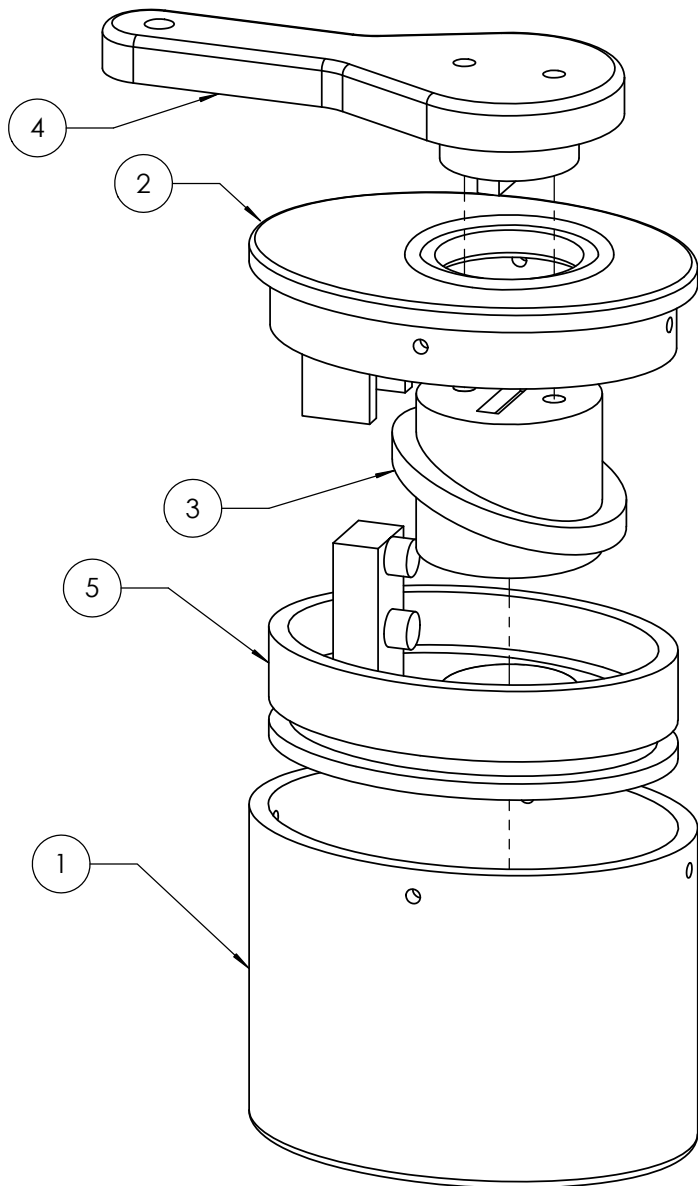

ITEM NO.	PART NUMBER	DESCRIPTION	QTY
1	P101	OUTER CASE	1
2	P102	CASE TOP	1
3	P103	DRIVER WITH WAVE	1
4	P104	HAND CRANK	1
5	P105	PISTON	1
6		#4 X 3/8" MACHINE SCREW	4
7		#4 FLAT WASHER	6
8		2" O.D. x .103" O-RING	1
9		#4 X .5" 32 TPI BOLT	2
10		#4 HEX NUT	2
11		CRANK KNOB ASSEMBLY	1
12	CV082.001-154.01	DUCKBILL VALVE	1
13	UM085.004-151.01	UMBRELLA VALVE	1
14		THREAD INSERT	1
15		INFLATION NEEDLE	1

NOTES:

- 1) CASE IS SCREWED TO TOP CASE USING ITEMS NO.6 AND NO.7
- 2) O-RING FITS AROUND GLAND ON PISTON
- 3) DRIVER IS BOLTED TO HAND CRANK USING ITEMS NO.7, NO.9, AND NO.10
- 4) ITEMS NO.12 AND NO.13 ARE MINI-VALVE PART NUMBERS
- 5) ITEM NO.12 IS FOR COMPRESSION STROKE VALVE SEAT
- 6) ITEM NO.13 IS FOR EXPANSION STROKE VALVE SEAT
- 7) ITEM NO.14 IS PRESS FIT INTO BOTTOM OF CASE
- 8) ITEM NO.15 SCREWS INTO ITEM NO.14

MINIPUMP 2011-2012



DRAWN BY: BRITTA BERG-JOHANSEN

INIT:

CKD BY:

INIT:

TOLERANCE:

UNITS: INCHES

MATERIAL: ABS

NEXT ASSY:

SCALE: 1 : 1

TITLE: MINI PUMP ASSEMBLY

DWG #: PA01

DATE: 1/10/12

GROUP: MINI PUMP

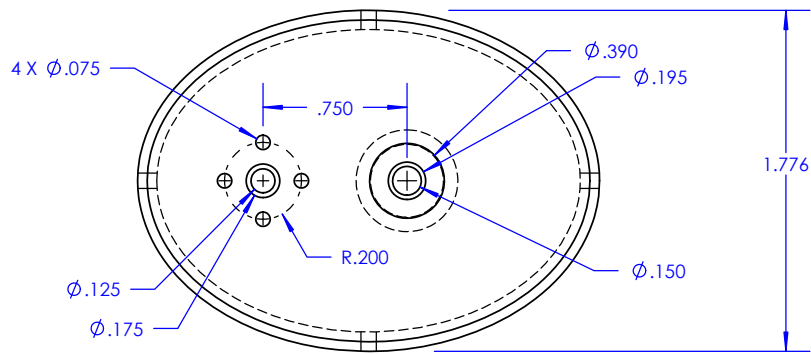
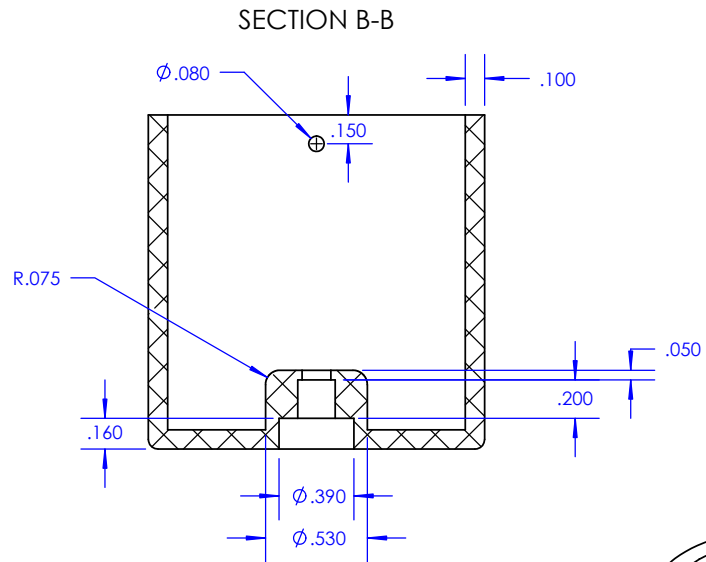
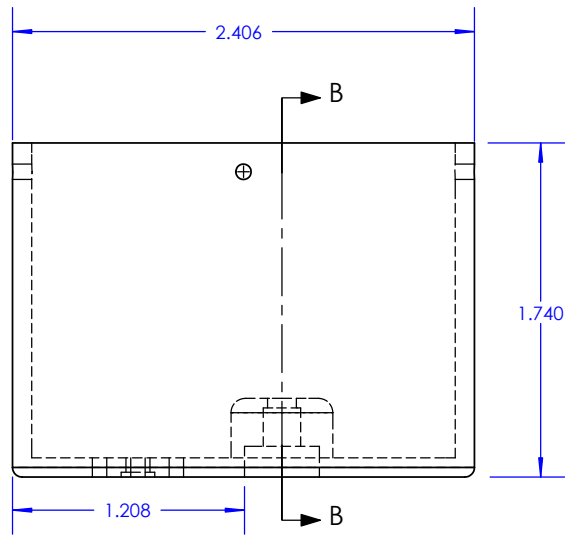

BOTTOM VIEW

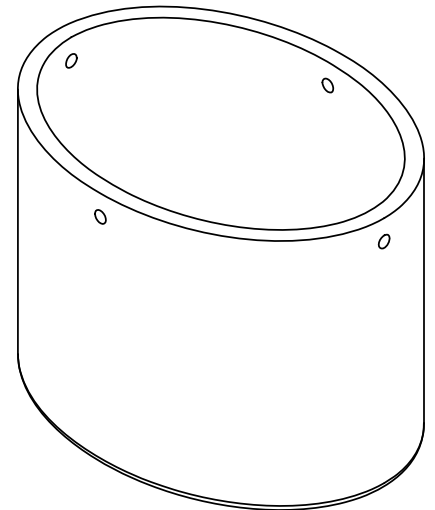

NOTES:

- 1) BORE ON BOTTOM IS FOR MATING WITH THREAD INSERT FOR THE INFLATION NEEDLE

MINIPUMP 2011-2012



DRAWN BY: BRITTA BERG-JOHANSEN

INIT:

CKD BY:

INIT:

TOLERANCE:

UNITS: INCHES

MATERIAL: ABS

NEXT ASSY: PA01

SCALE: 1 : 1

TITLE: OUTER CASE

DWG #: P101

DATE: 1/10/12

GROUP: MINI PUMP

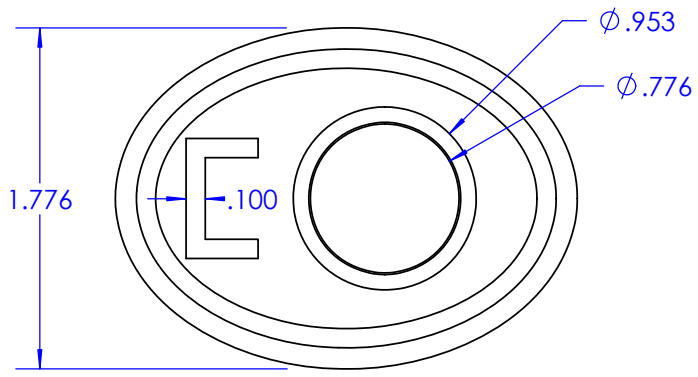
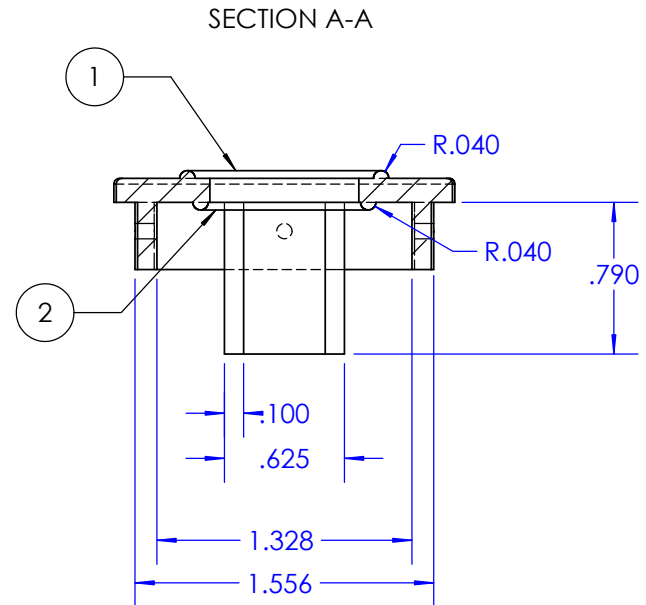
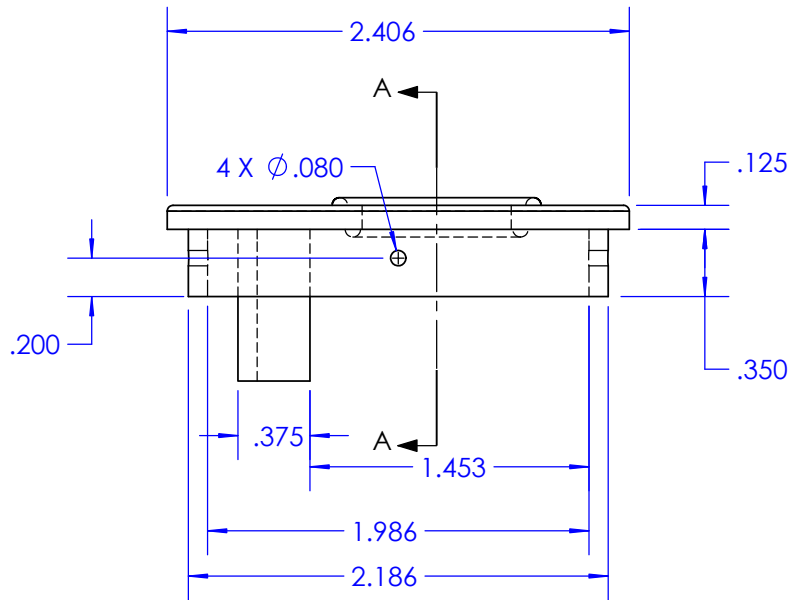

BOTTOM VIEW

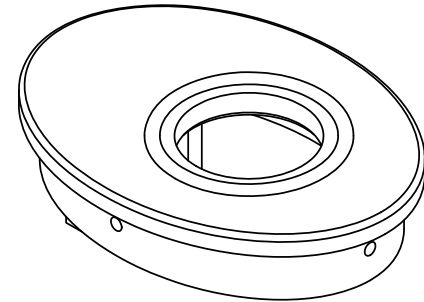

NOTES:

- 1) FEATURES 1 AND 2 ARE RUB RAILS DESIGNED TO REDUCE SLIDING FRICTION BETWEEN DRIVER AND CRANK

MINIPUMP 2011-2012



DRAWN BY: BRITTA BERG-JOHANSEN

INIT:

CKD BY:

INIT:

TOLERANCE:

UNITS: INCHES

MATERIAL: ABS

NEXT ASSY: PA01

SCALE: 1 : 1

TITLE: CASE TOP

DWG #: P102

DATE: 1/7/12

GROUP: MINI PUMP

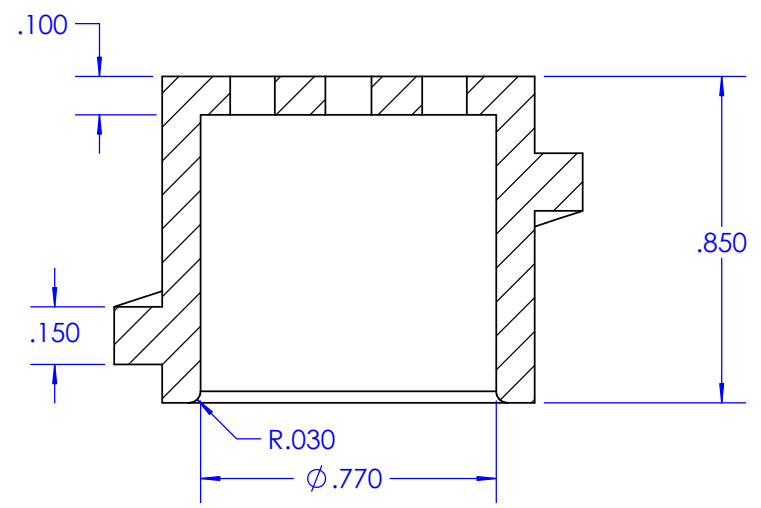
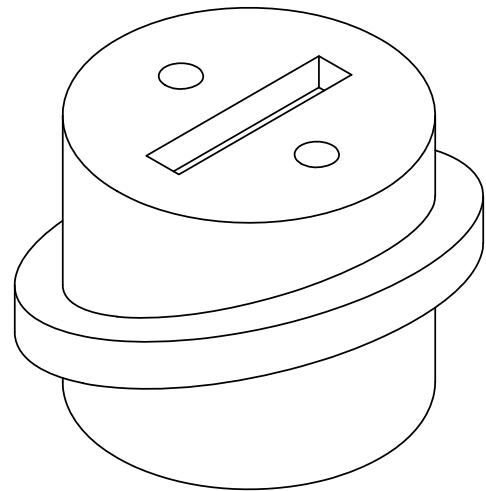
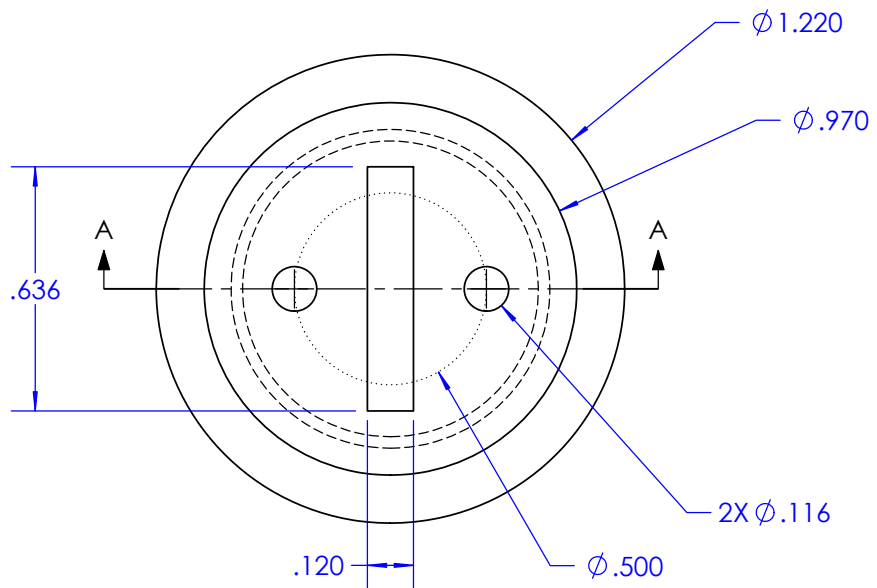

SECTION A-A

NOTES:

- 1) SLIDER WAVE SHOWN HAS AN AMPLITUDE OF .20" (STROKE OF .40")
- 2) SLOT ON DRIVER TOP MATES WITH CRANK TO PROVIDE TORQUE STRENGTH
- 3) THROUGH HOLES ARE FOR BOLTING DRIVER TO CRANK

MINIPUMP 2011-2012



DRAWN BY: BRITTA BERG-JOHANSEN		INIT:	CKD BY:		INIT:
TOLERANCE:		UNITS: INCHES		MATERIAL: ABS	
NEXT ASSY: PA01		SCALE: 2 : 1		TITLE: DRIVER WITH WAVE	
DWG #: P103		DATE: 1/7/12		GROUP: MINI PUMP	

5

4

3

2

1

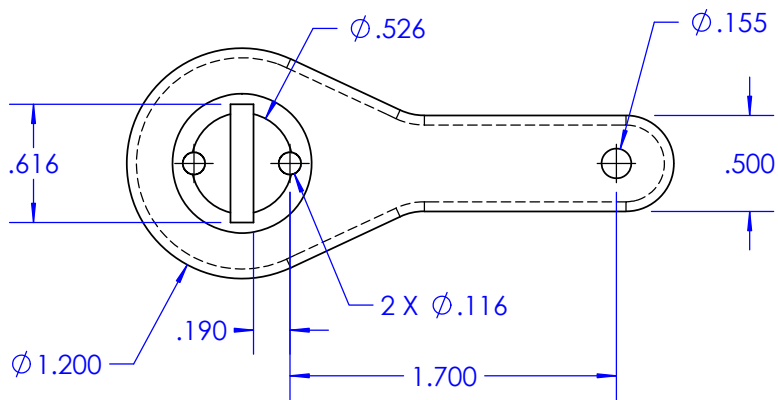
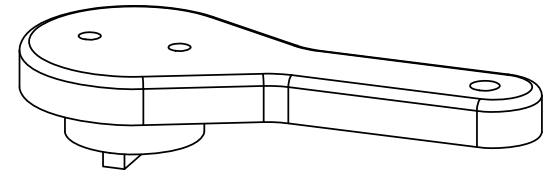
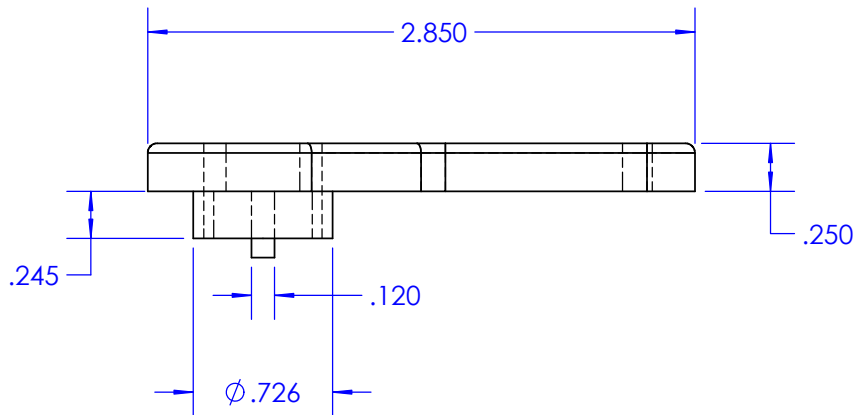

NOTES:

- 1) THROUGH HOLE AT CRANK END IS FOR CRANK KNOB. FOR PROTOTYPE, CRANK KNOB WILL BE A BOLT AND SPACER SLEEVE
- 2) THE REMAINING TWO THROUGH HOLES ARE FOR BOLTING CRANK TO DRIVER

MINIPUMP 2011-2012



DRAWN BY: BRITTA BERG-JOHANSEN

INIT:

CKD BY:

INIT:

TOLERANCE:

UNITS: INCHES

MATERIAL: ABS

NEXT ASSY: PA01

SCALE: 1 : 1

TITLE: HAND CRANK

DWG #: P104

DATE: 1/7/12

GROUP: MINI PUMP

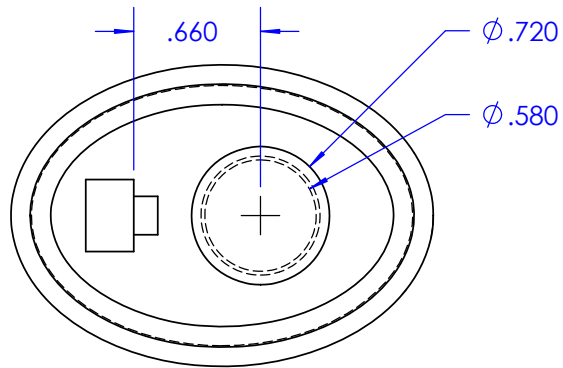

NOTES:

- 1) GLAND DIMENSIONS ARE ADAPTED FROM PARKER O-RING DATA
- 2) .103" O-RING WITH 2" O.D.

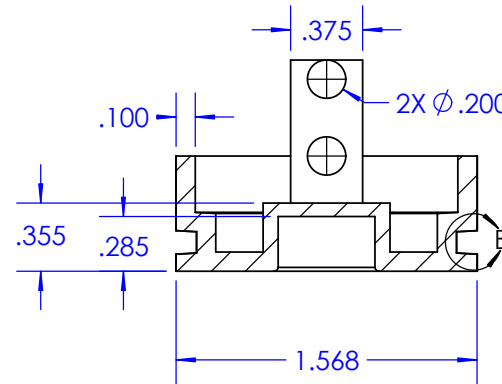
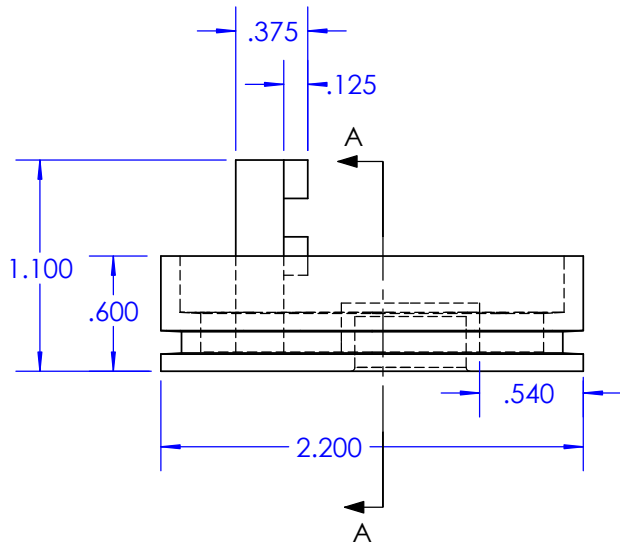
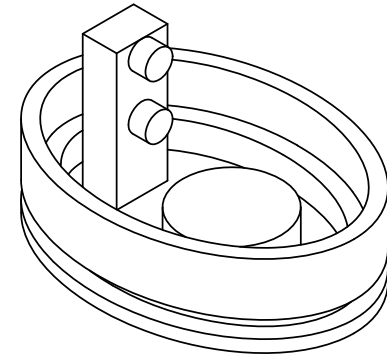

SECTION A-A

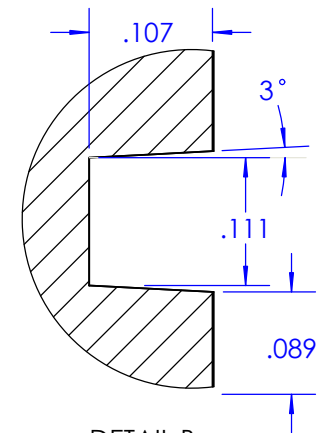

DETAIL B
SCALE 6 : 1

MINIPUMP 2011-2012



DRAWN BY: BRITTA BERG-JOHANSEN

INIT:

CKD BY:

INIT:

TOLERANCE:

UNITS: INCHES

MATERIAL: ABS

NEXT ASSY: PA01

SCALE: 1 : 1

TITLE: PISTON

DWG #: P105

DATE: 1/10/12

GROUP: MINI PUMP

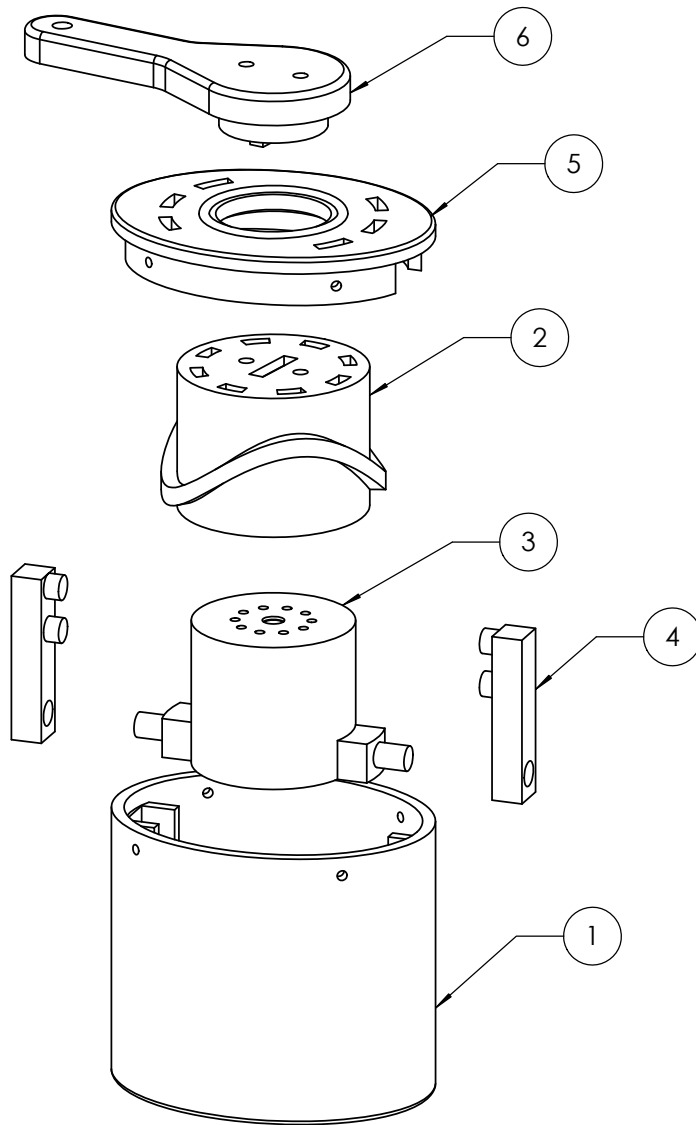

ITEM NO.	PART NO.	DESCRIPTION	QTY.
1	P201	OUTER CASE	1
2	P203	DRIVER WITH WAVE	1
3	P206	CYLINDER	1
4	P205	PEG STAND	2
5	P202	CASE TOP	1
6	P204	HAND CRANK	1
7	P207	GLAND CAP	1
8		#4 X 3.8" MACHINE SCREW	4
9		#4 FLAT WASHER	4
10	4444-119 5716	1.125" O.D. X .103" X-RING	1
11		#4 X .5" 32 TPI BOLT	2
12		#4 HEX NUT	2
13		CRANK KNOB ASSEMBLY	1
14	CV082.001-154.01	DUCKBILL VALVE	1
15	UM085.004-151.01	UMBRELLA VALVE	1
16		THREAD INSERT	1
17		INFLATION NEEDLE	1

NOTES:

- 1) CASE IS SCREWED TO TOP CASE USING ITEMS NO.8 AND NO.9
- 2) X-RING FITS AROUND THE GLAND ON ITEM NO.7
- 3) DRIVER IS BOLTED TO HAND CRANK USING ITEMS NO.9, NO.11, AND NO.12
- 4) ITEMS NO.14 AND NO.15 ARE MINI-VALVE PART NUMBERS
- 5) ITEM NO.14 IS FOR COMPRESSION STROKE VALVE SEAT
- 6) ITEM NO.15 IS FOR EXPANSION STROKE VALVE SEAT
- 7) ITEM NO.16 IS PRESS FIT INTO BOTTOM OF CASE
- 8) ITEM NO.17 SCREWS INTO ITEM NO.16
- 9) ITEM NO.7, GLAND CAP, IS NOT SHOWN

MINIPUMP 2011-2012



DRAWN BY: STEPHEN SCRUGGS

INIT:

CKD BY:

INIT:

TOLERANCE:

UNITS: INCHES

MATERIAL: ABS

NEXT ASSY:

SCALE: 2 : 3

TITLE: MINI PUMP V2 ASSEMBLY

DWG #: PA02

DATE: 1/31/12

GROUP: MINI PUMP

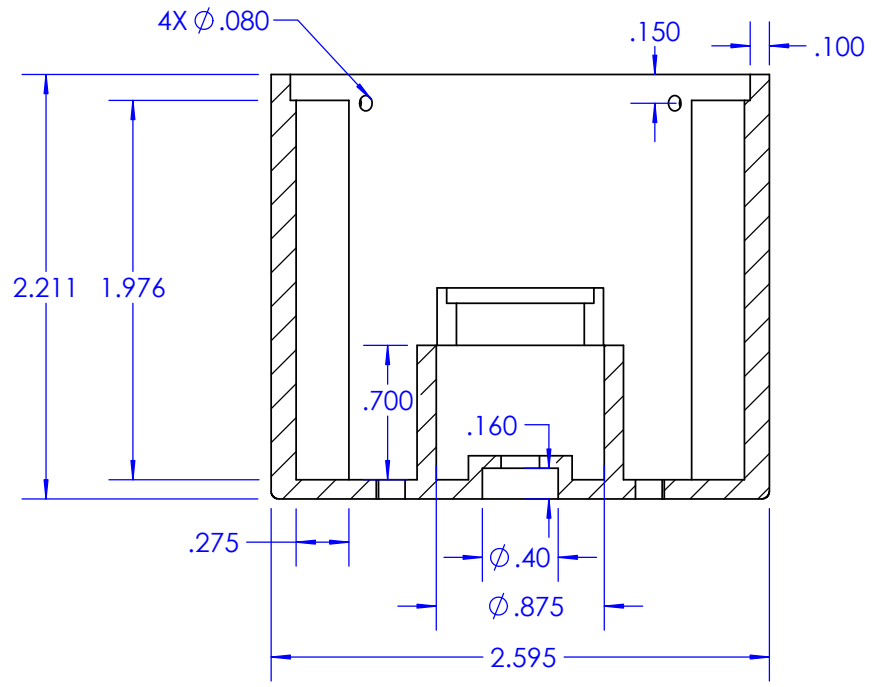
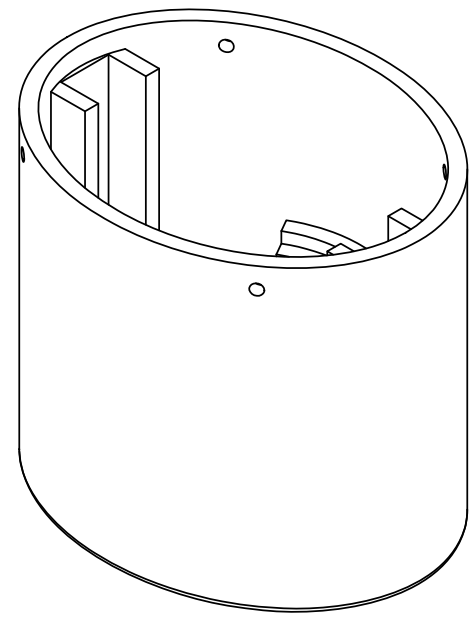
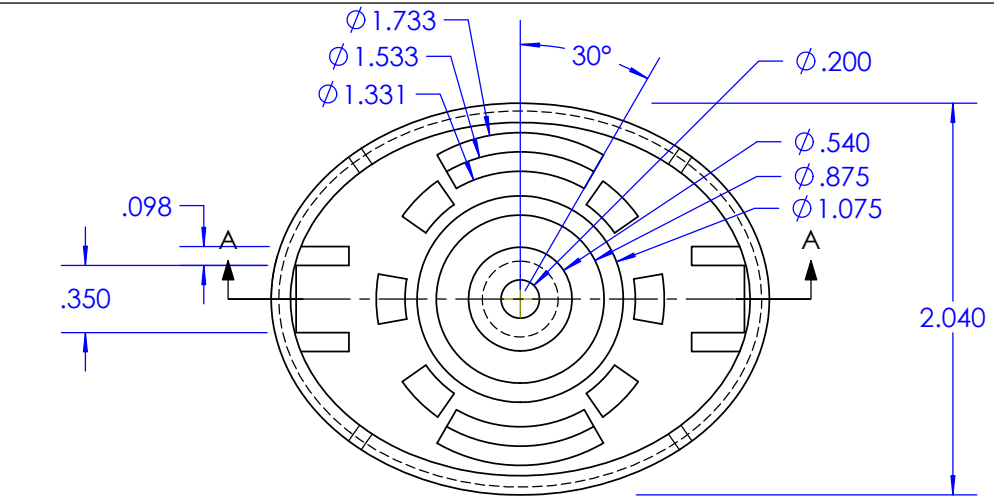

SECTION A-A

NOTES:

- 1) BORE ON BOTTOM IS FOR MATING WITH THREAD INSERT FOR THE INFLATION NEEDLE

MINIPUMP 2011-2012



DRAWN BY: STEPHEN SCRUGGS		INIT:	CKD BY:	INIT:
TOLERANCE:	UNITS: INCHES		MATERIAL: ABS	
NEXT ASSY: PA02	SCALE: 1 : 1		TITLE: CASE	
DWG #: P201	DATE: 1/31/12		GROUP: MINI PUMP	

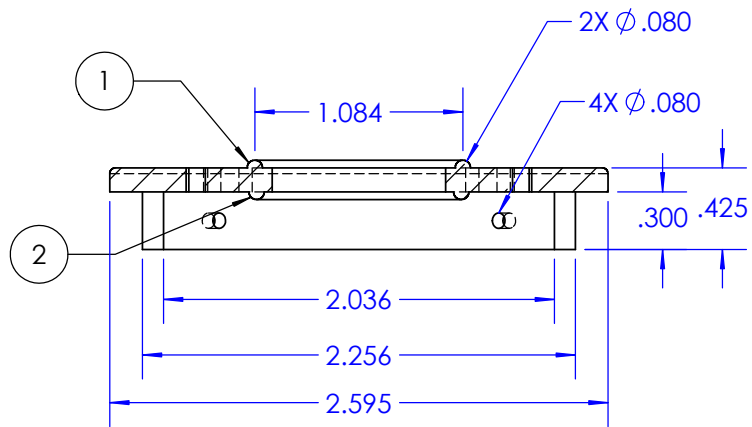

SECTION A-A

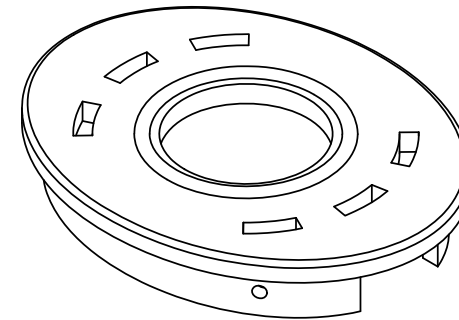

BOTTOM VIEW

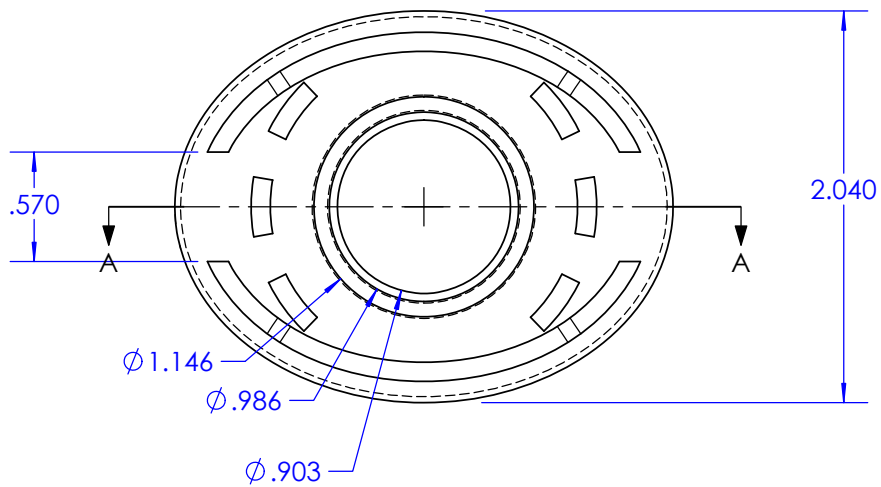

NOTES:

1) FEATURES 1 AND 2 ARE RUB RAILS DESIGNED TO REDUCE SLIDING FRICTION BETWEEN DRIVER AND CRANK

MINIPUMP 2011-2012



DRAWN BY: BRITTA BERG-JOHANSEN

INIT:

CKD BY:

INIT:

TOLERANCE:

UNITS: INCHES

MATERIAL: ABS

NEXT ASSY: PA02

SCALE: 1 : 1

TITLE: CASE TOP

DWG #: P202

DATE: 2/14/12

GROUP: MINI PUMP

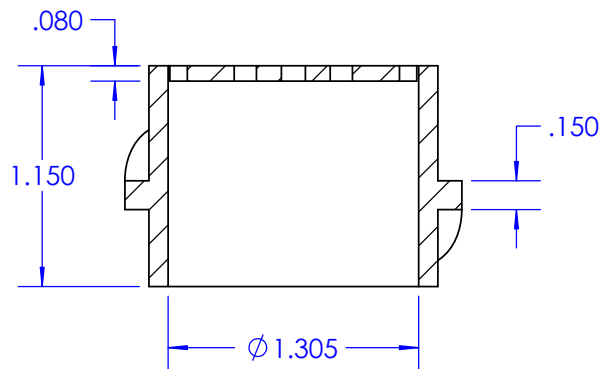
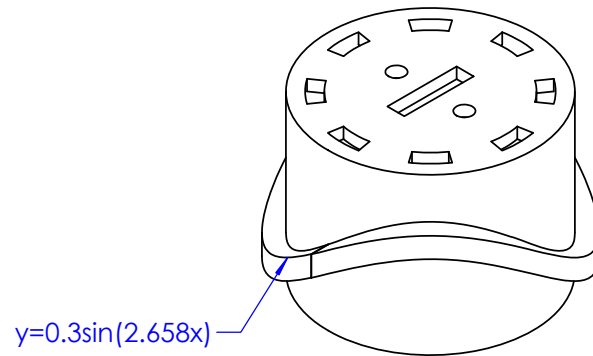
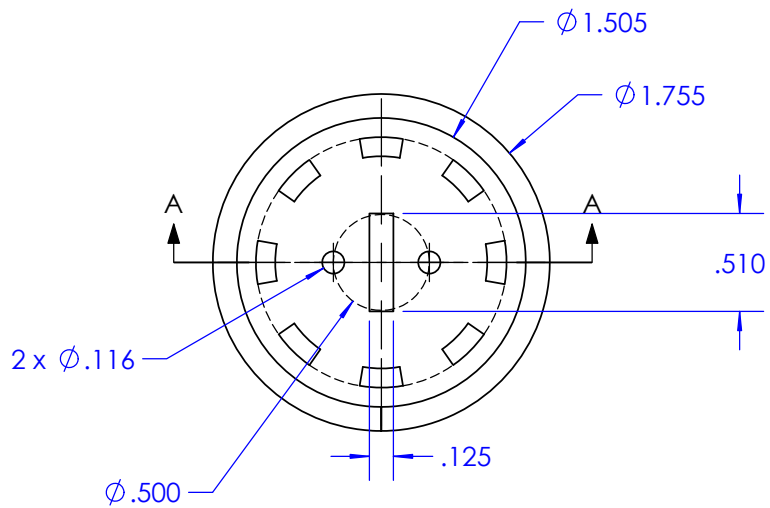

SECTION A-A

NOTES:

- 1) SLIDER WAVE SHOWN HAS AN AMPLITUDE OF .30" (STROKE OF .60")
- 2) SLOT ON DRIVER TOP MATES WITH CRANK TO PROVIDE TORQUE STRENGTH
- 3) THROUGH HOLES ARE FOR BOLTING DRIVER TO CRANK

MINIPUMP 2011-2012



DRAWN BY: STEPHEN SCRUGGS

INIT:

CKD BY:

INIT:

TOLERANCE:

UNITS: INCHES

MATERIAL: ABS

NEXT ASSY: PA02

SCALE: 1 : 1

TITLE: DRIVER

DWG #: P203

DATE: 1/31/12

GROUP: MINI PUMP

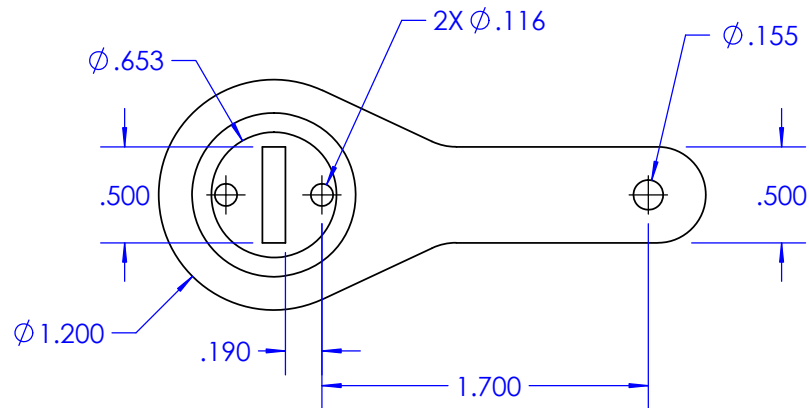
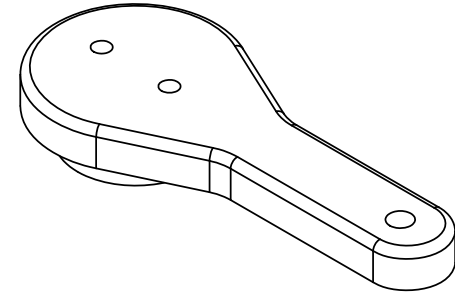
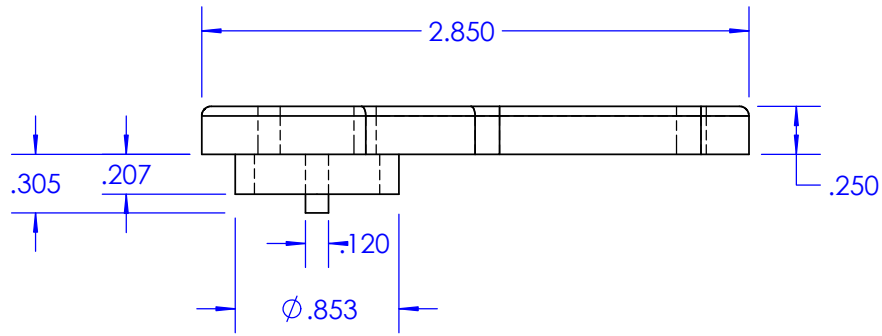

NOTES:

- 1) THROUGH HOLE AT CRANK END IS FOR CRANK KNOB.
- 2) REMAINING TWO THROUGH HOLES ARE FOR BOLTING CRANK TO DRIVER

MINIPUMP 2011-2012



DRAWN BY: BRITTA BERG-JOHANSEN

INIT:

CKD BY:

INIT:

TOLERANCE:

UNITS: INCHES

MATERIAL: ABS

NEXT ASSY: PA02

SCALE: 1 : 1

TITLE: HAND CRANK

DWG #: P204

DATE: 2/14/12

GROUP: MINI PUMP

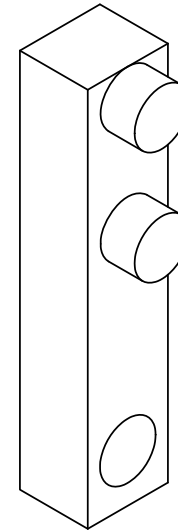
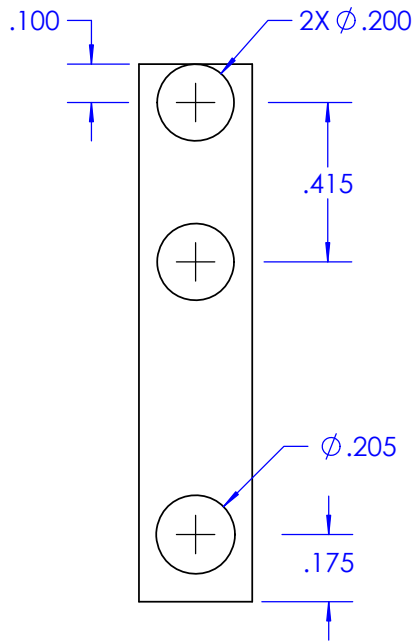
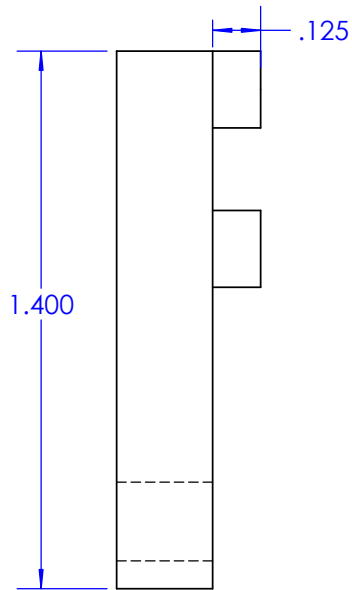
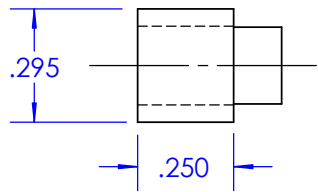

MINIPUMP 2011-2012



DRAWN BY: BRITTA BERG-JOHANSEN

INIT:

CKD BY:

INIT:

TOLERANCE:

UNITS: INCHES

MATERIAL: ABS

NEXT ASSY: PA02

SCALE: 2 : 1

TITLE: ATTACHMENT POST

DWG #: P205

DATE: 2/14/12

GROUP: MINI PUMP

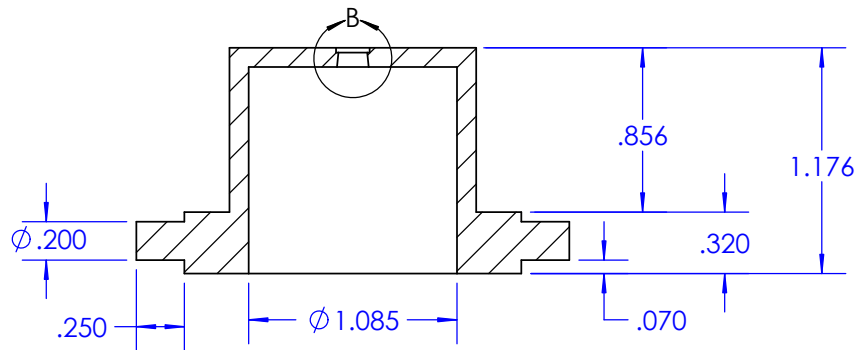
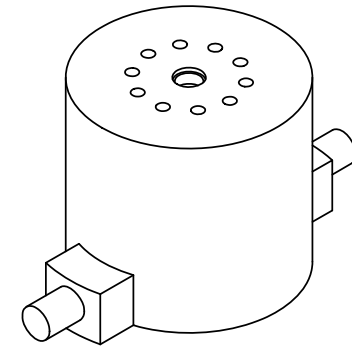
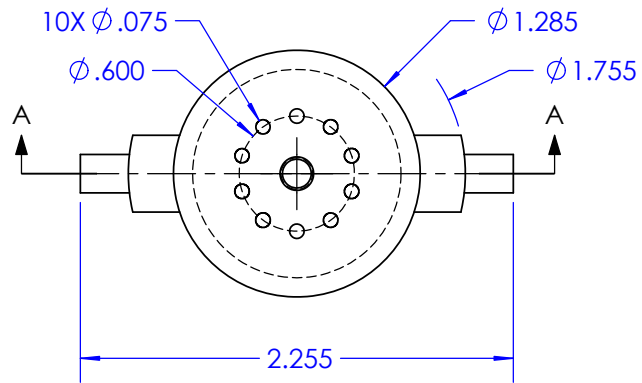

SECTION A-A

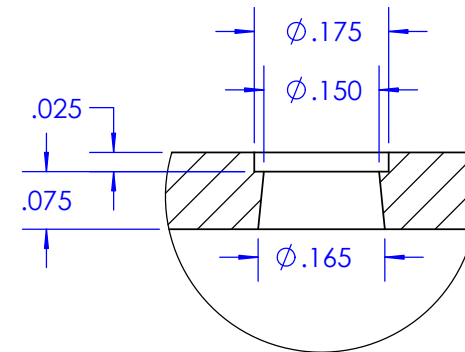

DETAIL B
 SCALE 4 : 1

MINIPUMP 2011-2012



DRAWN BY: BRITTA BERG-JOHANSEN

INIT:

CKD BY:

INIT:

TOLERANCE:

UNITS: INCHES

MATERIAL: ABS

NEXT ASSY: PA02

SCALE: 1 : 1

TITLE: CYLINDER

DWG #: P206

DATE: 2/14/12

GROUP: MINI PUMP

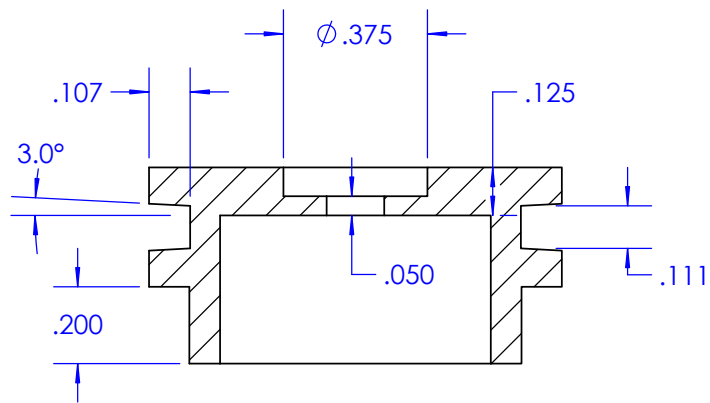

SECTION A-A

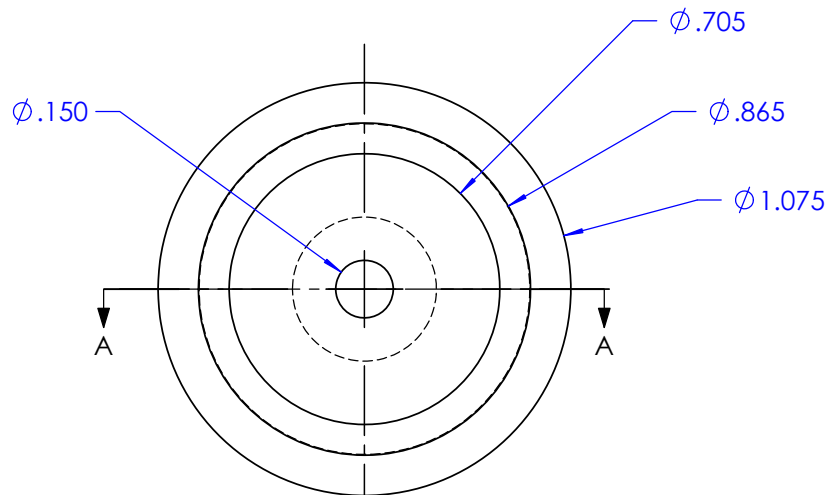
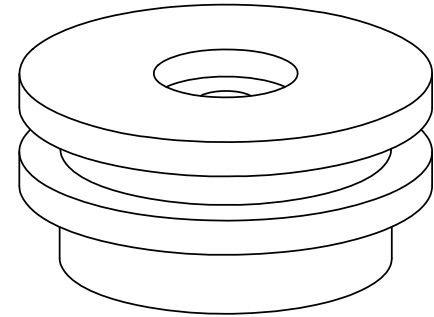

BOTTOM VIEW

NOTES:

- 1) GLAND DIMENSIONS ARE ADAPTED FROM PARKER O-RING DATA
- 2) .103" O-RING WITH 1.125" O.D.

MINIPUMP 2011-2012



DRAWN BY: STEPHEN SCRUGGS

INIT:

CKD BY:

INIT:

TOLERANCE:

UNITS: INCHES

MATERIAL: ABS

NEXT ASSY: PA02

SCALE: 2:1

TITLE: GLAND CAP

DWG #: P207

DATE: 2/14/12

GROUP: MINI PUMP