

# **Low Cost Vacuum Chamber Design for Electromagnetic Railgun Operation**

A Senior Project

presented to

the Faculty of the Department of Aerospace Engineering  
California Polytechnic State University, San Luis Obispo

In Partial Fulfillment

of the Requirements for the Degree

Bachelor of Science

by

Andrew W. Bothwell and David J. Foster

June, 2012

© 2012, Andrew W. Bothwell and David J. Foster

1

American Institute of Aeronautics and Astronautics

# Low Cost Vacuum Chamber Design for Electromagnetic Railgun Operation

Andrew W. Bothwell<sup>1</sup> and David J. Foster<sup>2</sup>  
California Polytechnic State University, San Luis Obispo, CA, 93401

This report describes the design and fabrication of a low cost vacuum chamber capable of supporting the operation of an electromagnetic railgun. This would be used to simulate the impact of high velocity impacts in space. The vacuum chamber was constructed out of 10in diameter 10ft PVC pipe with a Wye fitting for viewing impacts during testing. The chamber was designed to accommodate a 6.5in X 6.5in X 60in railgun. The vacuum chamber feedthroughs were designed to be able to carry 1-2Mamps at 8kV to the railgun. The vacuum chamber is capable of reaching 50 Torr and remaining under 100 Torr for 11 minutes. The final cost of the chamber was \$1325.

## Nomenclature

$A$	=	cross-sectional area of the schedule 80 PVC, $in^2$
$C$	=	shape constant for flat plate stress analysis
$D$	=	diameter of the stress circle present on flat plate, $in$
$F$	=	tensile force present on PVC, $lbf$
$r_{inner}$	=	inner radius of schedule 80 PVC, $in$
$r_{outer}$	=	outer radius of schedule 80 PVC, $in$
$\sigma_c$	=	tensile stress, $psi$
$\sigma_H$	=	hoop stress, $psi$
$\sigma_L$	=	longitudinal stress, $psi$
$\sigma_{max}$	=	maximum design stress, $psi$

## I. Introduction

Vacuum chamber technology has enabled scientists to simulate the space environment here on the surface of Earth. Simulating the space environment on the surface presents significant cost benefits to performing similar experiments in the vacuum of space. Similarly, with the advent of rail gun technology, high velocity impacts can be demonstrated here on ground level as well. A group of Cal Poly students have taken the initiative to utilize the properties of rail guns in order to simulate the behavior of high velocity impacts in space. Initial tests showed that the projectile expelled from the rail gun would create a plasma discharge which would distort any attempts at obtaining a clear video of the test. In order to mitigate the effects of plasma, it was decided to integrate both the vacuum chamber and rail gun technologies into one system. This system hopes to achieve a low-friction environment in which to simulate space-based impacts.

The project was assigned with a list of system requirements which would drive the design. Generally speaking, a cost-effective chamber, capable of accommodating the next-gen rail gun dimensions and electrical requirements was desired. Additionally, several other features were requested for the chamber to be designed to include: a set of break screens to measure projectile velocity, a viewport with which a camera could be placed to film the projectile impact, and a catching mechanism which could withstand an impact as great as 3 km/s. The next-gen rail gun had several key parameters which needed to be designed around. This included a current up to two million amps at eight kilovolts. The exact physical dimensions of the rail gun were unknown at the time of this design, so the chamber

---

<sup>1</sup> Undergraduate Student, Aerospace Engineering Department, 1 Grand Ave, San Luis Obispo, CA 93407

<sup>2</sup> Undergraduate Student, Aerospace Engineering Department, 1 Grand Ave, San Luis Obispo, CA 93407

was designed to house a variety of sizes. The initial budgetary requirement was to build the chamber at a cost under 500 dollars. After initial design plans showed this number to be unreasonable, a new cost restraint was set at 2000 dollars.

## II. Layout

The current version of the vacuum chamber consists of a schedule 80 PVC pipe attached to a schedule 80 PVC Wye Bell fitting. The Wye Bell fitting has a five inch socket depth. Interfaced to all three ends are 1" thick sheets of acrylic Plexiglas. The Plexiglas is mounted to the PVC by a pattern of 8 bolts that are fastened to aluminum blocks. The aluminum blocks are in turn mounted to the PVC pipe with epoxy. The general layout of all external features is shown in Figure 1.

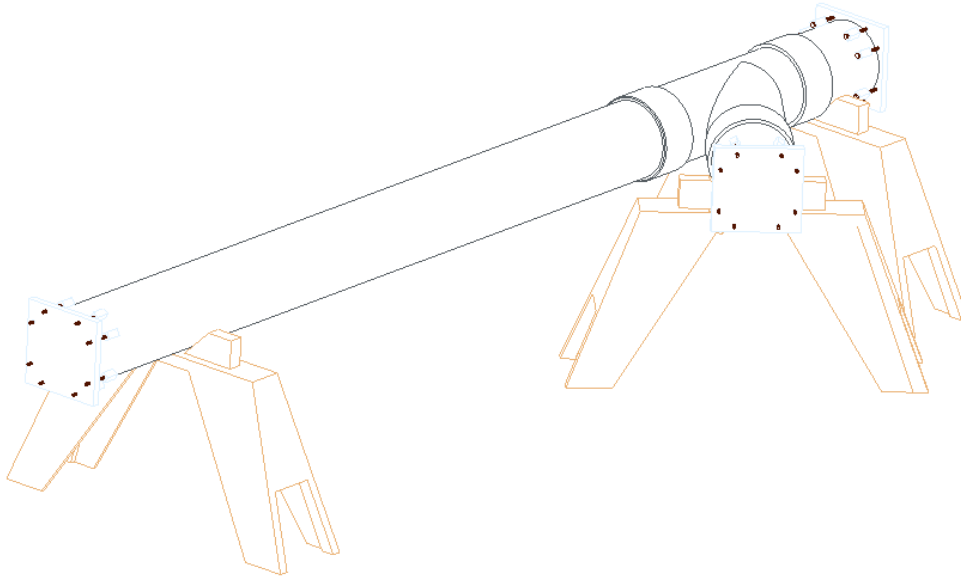

**Figure 1. The vacuum chamber assembly is comprised of a PVC chamber, acrylic Plexiglas end-plates, an aluminum bolt end-plate interface, and three support test stands.**

## III. Components

The following section describes the functionality and general design for each of the various components of the vacuum chamber. If applicable the assembly process is described as well.

### A. Chamber Body

The complete chamber body consists of four sections of schedule 80 PVC. This includes a 45° Wye bell fitting, two 18" sections, and a 120" section. Figure 2 shows the designated areas of operation within the chamber.

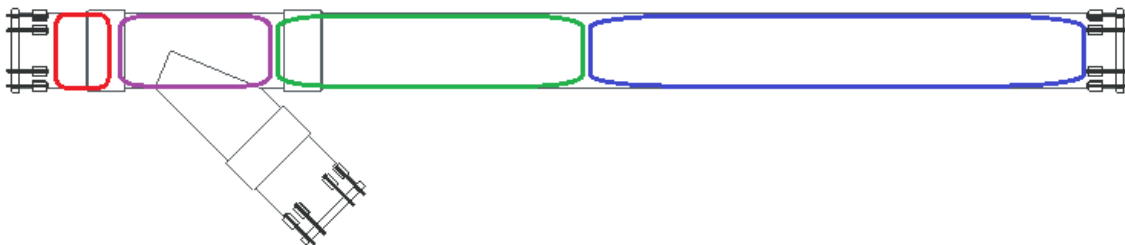
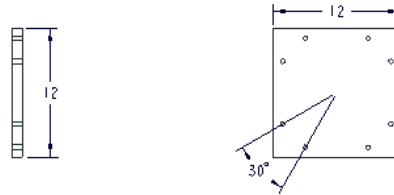

**Figure 2. The designated operational areas of the vacuum chamber consist of a rail gun housing (blue), a break screen setup (green), a viewing area (violet), and a target end (red).**

Of the four operational areas, only the viewing area has set dimensions, because it is driven by the available view area provided by the view port. The other areas are dependent on the design of the rail gun, which as of yet has not been finalized. Though not shown in Figure 2, the vacuum pump interface is located on the opposite side of the chamber from the primary viewing port, approximately seven feet from rail gun port.

### B. Plexiglas End-plates

The end-plates of the vacuum chamber are made from 1" thick clear acrylic Plexiglas. Because they are completely transparent, the end-plates also function as a viewport. Though one viewport is designated for filming the rail gun firing, the other two viewports could provide a look into the status of the rail gun and catching mechanism during the course of operations. They are designed to fit over the outer diameter of the chamber, with extra overlap allotted to allow for an interface scheme.

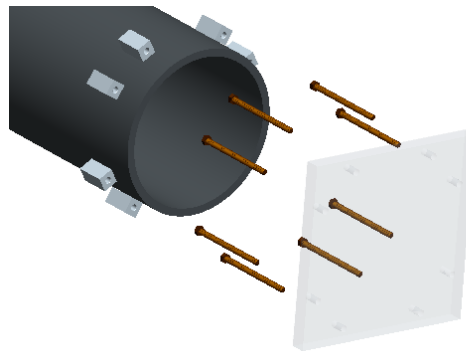

**Figure 3. Each Plexiglas endplate was cut into a square and patterned in the above fashion. Relevant units are in inches.**

The hole pattern was selected for mating purposes with the PVC, explained in further detail below.

### C. End-plate/PVC Interface

To create an initial seal across all the end-pieces of the vacuum chamber, a special design was created to mate the acrylic Plexiglas with the PVC. The selected method involved screwing the Plexiglas into eight aluminum blocks located around the chamber. The general design is shown in Figure 4.

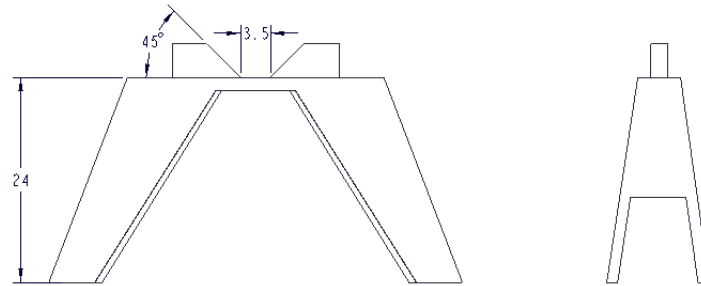

**Figure 4. Each Plexiglas endplate is mated to the PVC through a series of bolts connected to aluminum blocks located around the chamber.**

Initially, eight equidistant holes would be drilled around the Plexiglas. However, due to limited space available to drill through, a modified eight-hole design was selected, providing the same pressure hold as the first design, but with a slightly less equal distribution of the load.

### D. Test Stands

In order to support the vacuum chamber for integration and operational purposes, a set of test stands were designed to elevate the chamber assembly. In total, three test stands were used, with each stand depicted in figure 5.

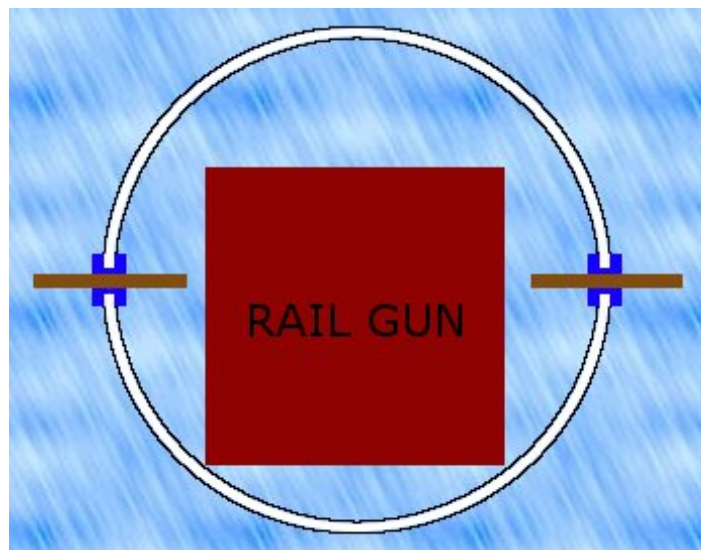

**Figure 5. Each of the three end ports will rest upon one of the three test stands. Units are in inches.**

Each end port was supported by a test stand, and was mounted on top of the 3.5 inch gap, shown in Figure 5. The test stands, along with supporting the weight of the vacuum chamber assembly, also maintain a near-perfect level surface for the rail gun to operate upon.. Each saw-horse is rated to carry 2000 pounds, so there was no worry of the test stand breaking under the weight of the chamber. Each of the three ports of the vacuum chamber had a saw-horse supporting it. To prevent the chamber from moving horizontally across each saw-horse, a cradle design was implemented on each one, using small blocks of wood. For extra security, a strip of plumbers tape wrapped over the top of the chamber and bolted to the sides of the cradle assembly. This test stand setup effectively held the entire vacuum chamber assembly in place through integration and testing.

### **E. Feedthroughs**

For the vacuum chamber application, electrical feedthroughs would be needed. Electrical feedthroughs are used extensively in vacuum chamber applications, but usually for metal chambers. Having a chamber made of PVC made the feedthrough design nontrivial. For this application, two types of feedthroughs would be required. One type would be required to carry high voltage, high current for the railgun, the other would be required to power the break screens. The high power feedthrough will be located near the railgun for easy integration of the railgun. This would be a low voltage, low current feedthrough. Since there are two break screens a total of 4 feedthroughs (2 per break screen) would be required. The concern with these feedthroughs is that the break screens are located approximately 3ft into the chamber. This is well outside a reachable distance so the feedthrough could not be located where the break screens are in the chamber. The feedthrough is therefore located near the opening. This would allow the break screens to be easily connected by a wire with enough slack to slide the break screens to its position. For the high power feedthroughs, they will be placed on opposite sides of the chamber to prevent any arcing during operation. This can be seen in Figure 6.



**Figure 6. The location of the feedthrough relative to the railgun.**

## F. Rail System

To allow all of the internal components to be installed a rail system was required. The primary concern was to maximize the potential area for the next generation rail gun. The dimensions for the rail gun have not yet been determined. So a preliminary design of the rail system was completed assuming the railgun would have the largest possible square cross section. It consists of a sheet of PVC and a rectangular bar of PVC. The bar is placed on the bottom and is intended to support the weight of all of the components. The second one would be used to ensure the components level and aligned. This second sheet would have a slot cut out of it to allow for the component rail interface. The interface would consist of two sheets. The first sheet would be the where the components mount to. The second one would fit into the slot of the rail system. This would not only keep the components of the system aligned, it would prevent any lateral motion. This preliminary design is shown in figure 7.

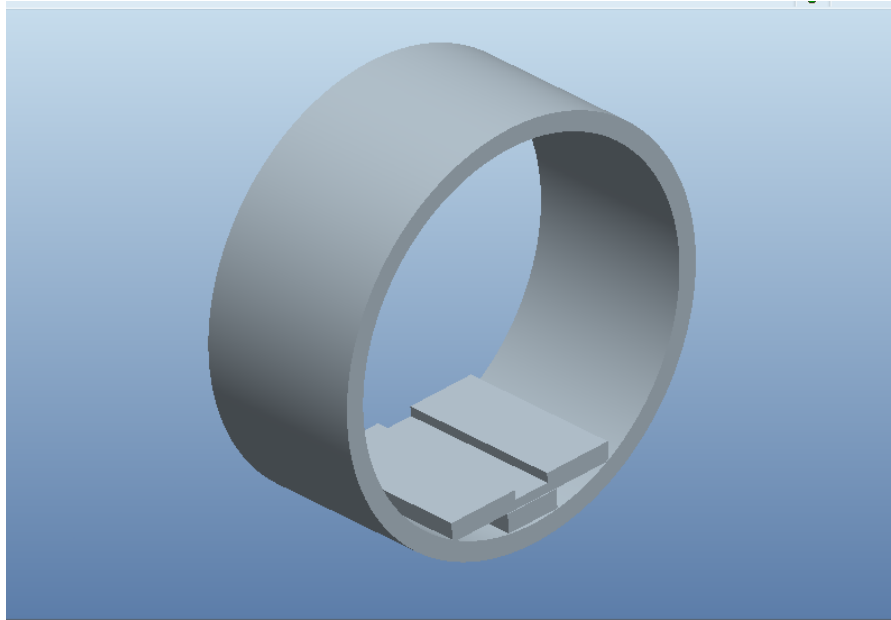

**Figure 7. Theoretical rail system for the vacuum chamber.**

## G. Pump Interface

The pump would need some way to connect to the vacuum chamber. The typical connections used in the Cal Poly Space Environments Lab utilize 1.25in PVC pipe and connectors. Since this has been proven to work and the vacuum chamber would be made out of PVC, this set up would be utilized. A 1.25in to 1.25in connector would be PVC glued into the chamber. The joint would then be covered in epoxy to ensure that the joint would not leak. This would allow for any system of PVC pipes to be connected to the chamber while limiting the number of permanent connections to the chamber. If the pipe layout to the pump ever changed, the vacuum chamber would not have to be reconfigured. The placement of the Pump interface was chosen to be at the center of the vacuum chamber. This would make the pressure low at both the railgun and target end. The pressure would be highest at the viewport of the Wye fitting. This is acceptable because there are no components here, so vacuum isn't as much a priority as it is for the railgun and target. This location also allows for the pump to be placed where the piping to the pump is minimized and will not interfere with the test stands.

## H. Break Screens

One measure of performance for the railgun is the velocity of the projectile. This will be measured two ways: a high-speed camera and break screens. Having two methods will increase the accuracy of the velocity calculation. The camera can be operated outside of the vacuum chamber, but the break screens cannot. They work by timing the duration between each break screen being struck by the projectile. Using the distance between the break screens the velocity can be calculated. Given the anticipated velocity of the projectile and the accuracy of the break screens, they would need to be at least 1ft apart.

## I. Catching Mechanism

Since the railgun will be firing a projectile inside the chamber, a method of safely decelerating the projectile was needed. This has not been designed or tested at this time. It has been preliminarily considered to be a whipple shield. Whipple shielding is used to stop hypervelocity projectiles on orbit. Since the railgun is intended to simulate these types of projectiles, this should be sufficient. Also, the first generation railgun has been fired at similar shielding designed by Brandon Holladay, which performed as desired. As an added precaution, a thick plate of steel may be added behind the other shielding.

## IV. Analysis

The following section describes the design process for each of the various components of the vacuum chamber.

### A. Primary Chamber Structure

#### Schedule 80 PVC Specifications

The primary benefit of using PVC is its relative low cost when compared to other metallic and plastic counterparts. Schedule 80 PVC was selected over other types of PVC because its thickness. Table 1 compares some general characteristics between schedules 80 and other 40.<sup>1,2</sup> The PVC quality that was considered was of type I, grade I, and conforms to the standards listed in ASTM D-1784.

**Table 1. Critical specifications of schedule 40 and 80 PVC**

	Schedule 40	Schedule 80
Max Pressure, psi	140	230
Thickness, in	0.387	0.629
Length, in	120	120
Tensile Strength, psi	7100	7100
Compressive Strength, psi	>8000	>8000

From the tables above, we can see that the schedule 80 PVC has nearly twice the thickness of schedule 40. Pressure vessel thickness plays a very important factor in the design of a vacuum chamber. For a cylindrical pressure vessel, the two principal stresses present on the chamber are the hoop stress and longitudinal stress. The hoop stress is normal to the longitudinal stress and is twice the magnitude. The orientation of hoop and longitudinal stress are shown below in figure 7.

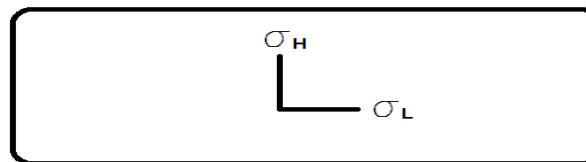
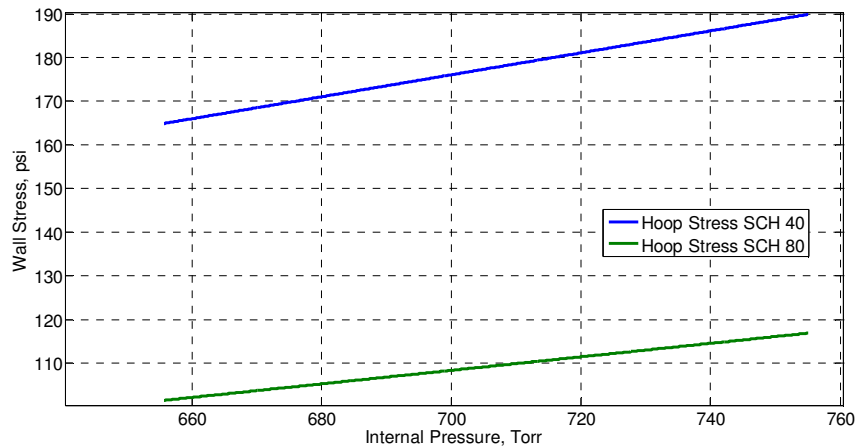

**Figure 8. The two principle stresses on a cylindrical pressure vessel are the hoop (circumferential) and longitudinal (axial) stresses.**

From figure 8, we see that the hoop stress is normal to the longitudinal stress. The hoop stress is twice the magnitude of the longitudinal stress. The equation for hoop stress is given in Eq. 1.

$$\sigma_{hoop} = \frac{Pr}{t} \quad (1)$$

where P is the internal pressure of the vessel, r is the inner diameter of the chamber, and t is the thickness of the chamber walls. We are more interested in the maximum stress present on the structure when pulling vacuum, so only the hoop stress was analyzed. Figure 9 shows a comparison of the hoop stress present on the chamber for schedule 40 and 80 PVC. The stresses are varied across a range of pressures from 100 Torr to 766 Torr. 100 Torr was selected as the starting pressure because that was the minimum pressure requirement for our chamber.



**Figure 9. Comparison of maximum stresses present upon a vacuum chamber constructed with schedule 40 and schedule 80 PVC.**

It should be noted that the horizontal axis displays the magnitude of the pressure differential between the inside and outside of the chamber walls. From Fig 9, it is readily apparent that the schedule 40 PVC endures greater stresses along the chamber than the schedule 80. Because of its superior wall thickness, the schedule 80 PVC is more suitable for these pressure chamber applications. Though both the schedule 40 and 80 pipes are rated to handle pressure loads of 14.7 psi, we chose the latter schedule for our applications. The schedule 80 was selected for its superior strength, as well as the fact that its thicker walls may provide better shielding in the case of a misfire of the rail gun inside the chamber.

Once it was confirmed that schedule 80 PVC would be the optimal choice for the vacuum chamber material, another trade study was conducted in order to decide whether it would be desirable to use a larger diameter pipe. It was required that a 10" minimum diameter pipe be used, however there may be more utility in having increased usable space inside the chamber, for various connections or modifications to be added at a later date. Figure 10 compares the maximum stress for a various diameters of schedule 80 pipes.

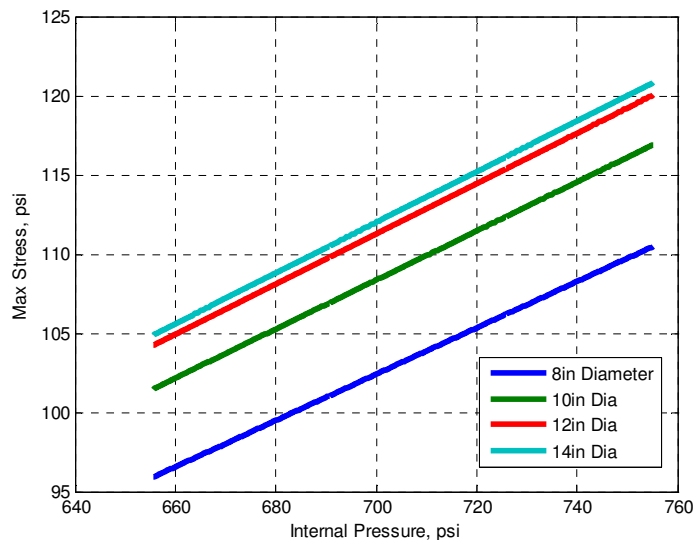

**Figure 10. Cross-comparison of several diameters of schedule 80 PVC.**

As Fig 10 shows, the maximum expected hoop stress becomes larger for every increase in pipe diameter. The maximum working pressure for all diameters is the same, at 230 psi. From a structural strength perspective, there is



no significant benefit in choosing a larger diameter pipe. However, because the cost of PVC increases significantly for larger diameters, it was concluded that the 10 inch pipe would be sufficient for the designated operations.

Aside from the hoop stresses, the compressive stress experienced on the ends of the pipe were analyzed. This was calculated by determining the load incurred by the external pressure forces on the PVC, via the Plexiglas end-plate. The external pressure will compress an area equal to a circle driven by the inner diameter of the PVC. This relationship is shown in equation 2.

$$F = P \times A = P_{ext}\pi(r_{inner})^2 \quad (2)$$

This force created by the external pressure, is focused on the cross-section of the pipe. The resulting stress can be calculated using equation 3.

$$\sigma_c = \frac{F}{A} = \frac{F}{\pi(r_{outer}^2 - r_{inner}^2)} \quad (3)$$

From this equation, we could estimate the expected stresses over a range of pressure values. This can be seen in figure 11.

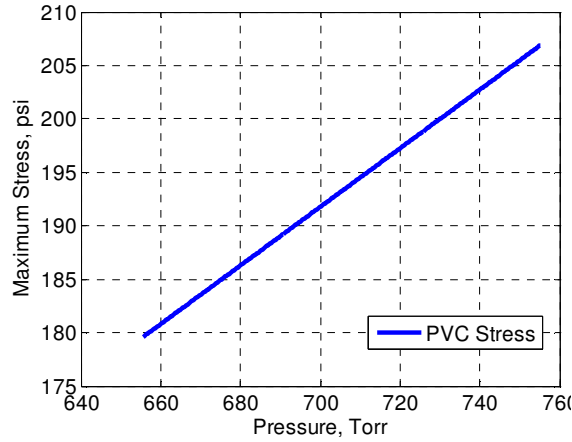

**Figure 11. This plot shows the expected stress incurred at each end of the chamber. It is apparent that the PVC does not exceed its design**

With an expected stress of 207 psi at full vacuum, this maximum stress is far below the tensile stress for which schedule 80 PVC is rated. According to ASTM D638, the tensile strength of a Type I, Grade I schedule 80 pipe is 7100 psi, far greater than the expected stress of 207. Although that does indicate an acceptable operation parameter, it also assumes ideal operating conditions, with the vacuum chamber operating at 73°F. As will be shown in a later section, the tensile strength will still be sufficient to carry the maximum stress at an increased operating temperature.

## B. Plexiglas End-Plates

The Plexiglas was chosen for its material properties and low cost. A breakdown of the physical characteristics of the Plexiglas we chose is seen below in table 2.<sup>3</sup>

	Clear Acrylic Plexiglas
Manufacturer	Estreet Plastics
Tensile Strength	10,000 psi
Shear Strength	9,000 psi
Thickness	1 in

The acrylic plates would not be experiencing the same stresses as the cylindrical chamber. A different equation, specific to flat plates, was used to determine the design stress. This equation is found in the British Pressure vessel code, PD5500.<sup>4</sup>

$$t = C \times D \times \sqrt{\frac{P}{\sigma_{max}}} \quad (4)$$

where t is the plate thickness, C is a coefficient dependent on plate shape, D is the diameter of the plate, P is the pressure inside the chamber, and  $\sigma_{max}$  is the maximum expected stress. Though the plates themselves are square, the stress concentration will be a circular cross-section. From this equation, we saw that for a one inch thick sheet of

Plexiglas, the stress it would incur at full vacuum would be about 510 psi. This is well below its rated strength of 10 ksi.<sup>3</sup>

**C. Plexiglas/PVC Pipe Interface**

To transfer the load from the Plexiglas to the pipe, aluminum blocks were integrated radially around the PVC pipe. The material chosen for this function was multipurpose aluminum, with shear strength of 30 ksi. Simple analysis showed that just a 1 in<sup>2</sup> block of aluminum could withstand the predicted induced shear stress. For extra strength, we doubled the length of each block to 2 inches. Each block was then epoxied onto the outer circumference in the corresponding pattern shown in Fig 12. The epoxy chosen for this purpose is rated to carry stresses in excess of 1040 psi.

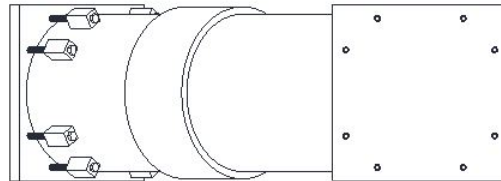

**Figure 12. The Aluminum blocks were mounted in accordance with the hole pattern of the Plexiglas plates.**

In order to secure the Plexiglas to the aluminum blocks, a series of 3/8 inch bolts were driven through the radially spaced holes, and secured with simple hex nuts.

**D. Thermal Degradation Considerations**

A limiting factor of using PVC for our design is its structural sensitivity to moderate and extreme changes in temperature. Table 3 gives a brief summary of the PVC strength over a variety of operating temperatures.<sup>2</sup>

Temp, F	Factor	W.P. Strength SCH80, psi	Yield Hoop Stress SCH80, psi
73	1	230	1840
80	0.88	202.4	1619
90	0.91	209.3	1674
100	0.82	188.6	1509
110	0.72	165.6	1325
120	0.65	149.5	1196
130	0.57	131.1	1049
140	0.50	115	920
150	0.42	96.6	773
160	0.40	92	736
170	0.29	66.7	534
180	0.25	57.5	460
200	0.20	46	368

It is well known that the strength of PVC degrades as temperature increases. Still, from the table above, we see that the PVC should still maintain rigidity even at relatively high temperatures. The environmental temperature will not significantly affect the strength of the chamber. Even on a hot day (110 °F), the yield hoop stress will be nearly ten times greater than the expected hoop stress at full vacuum. The highest expected temperature the chamber should see is about 140 °F at the feedthroughs. Assuming some of the heat is dissipated immediately to the chamber, a

section of the PVC would experience ~50% decrease in its strength. Still, at 920 psi, its allowable hoop stress is still well above the strength needed to hold vacuum (~117 psi).

### E. High Power Feedthrough

The railgun feedthrough would need to be able to support a load of 1 to 2 million amps at up to 8kV and would be impulsive. Commercially available feedthroughs are rated for a maximum steady state load. A commercially available feedthrough may have worked for this application, but would have been a risk in that it would have to operate not as intended. These feedthroughs would each cost over \$100 each and are not easily able to interface with a curved PVC surface. To make them interface with the PVC would require the same work as just designing new feedthroughs for the vacuum chamber. Lastly these feedthroughs would not allow for the rail to connect to them without modification given the space constraint. This would increase cost and again require the same work as just designing new feedthroughs. It was for these reasons it was decided to design feedthroughs specific to the vacuum chamber.

The primary concerns for the designed feedthroughs were leak prevention and heat generation. To be electrically conductive, the feedthrough would be made from copper or aluminum. The copper would be more conductive, but more expensive. It was initially decided to use copper to not hurt the performance of the railgun. To ensure a good seal a few options were considered. The first design of the feedthrough was simply to have a copper rod through the wall of the PVC and held in place with epoxy. This would be relatively inexpensive and simple to make. The problem with this design is that there was a concern that the epoxy would be able to hold under vacuum and not leak. The second design was to thread the copper rod and the PVC and use Teflon tape and vacuum grease similar to how the convectron gages attach. The concern here was threading PVC. It could easily get cross threaded. Lastly was to use thermal contraction to create an interference fit with the copper rod and PVC. This could also be epoxied into place to add more support and prevent leaks. The concerns here were this design was also unproven and cooling the rod to make it small enough could be difficult. The first design was chosen for its simplicity. It would need to be tested, but if it worked it would be the easiest and cheapest to make.

To test this design a proof of concept test was performed. A 0.5in diameter copper rod was epoxied using Loctite® Quick Set epoxy into a 1.25in PVC pipe which was capped on one end with a PVC cap that was chemically welded into place with PVC glue. At the other end of the pipe a convectron gage was screwed into the PVC. The PVC pipe was then connected to a Welch 1397 manual pump. The test apparatus was then subject to vacuum. To determine if the leak rates were normal, Max Glicklin was consulted. He is a graduate student familiar with vacuum chambers and their operation. He determined that the leaking associated with the test apparatus was reasonable.

After proving the epoxy would be sufficient for leaks, temperature was still a concern. The PVC is rated to support a maximum operating temperature of 60°C. To determine how feedthrough diameter affected the temperature of the feedthrough after firing a MATLAB code was used that was developed by Jeff Maniglia, the graduate student responsible for the railgun design. His model produced the relationship between feedthrough temperature and diameter that can be found in Fig. 13.

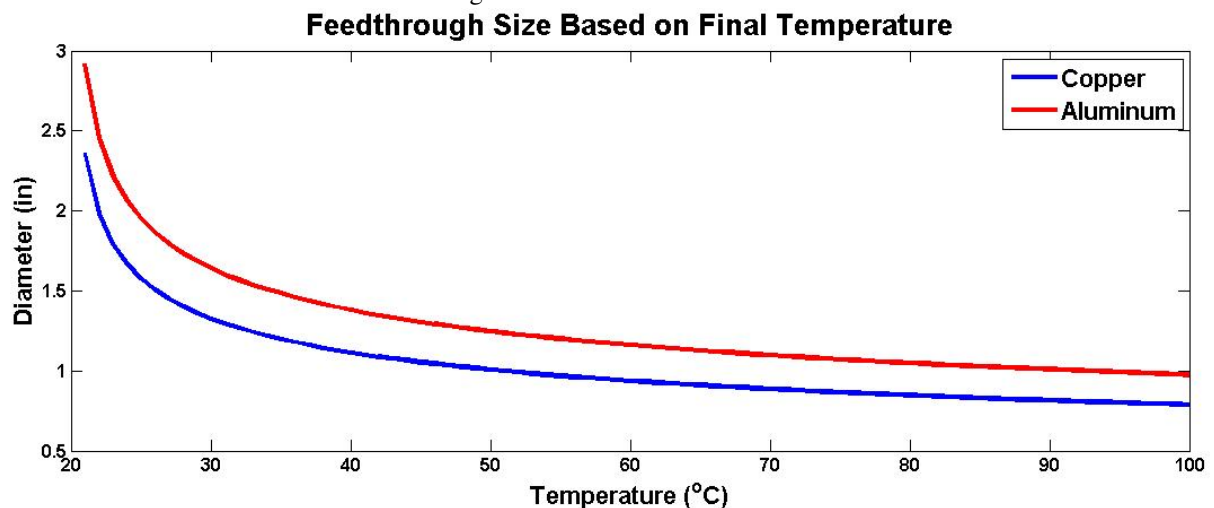
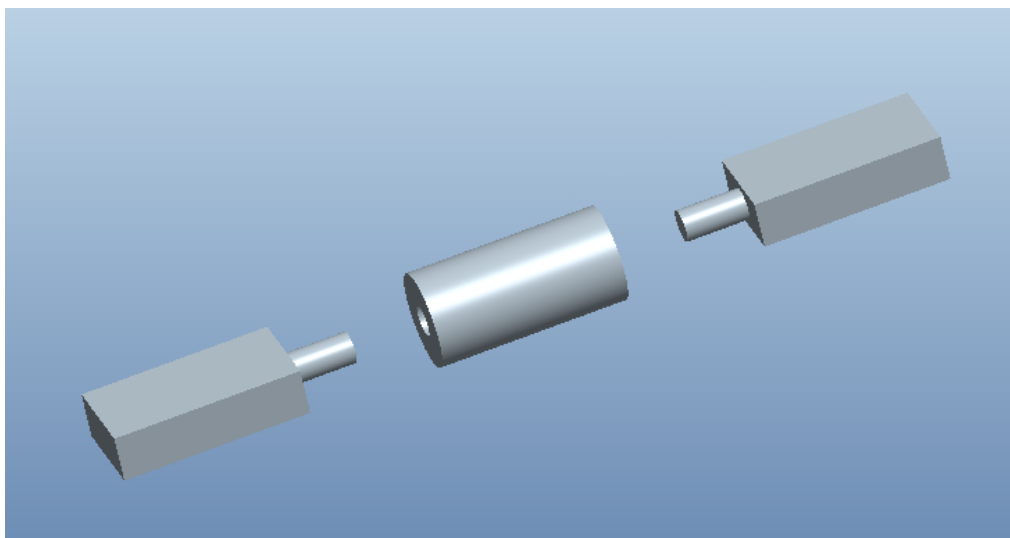

Figure 13. The relationship between the final temperature of the feedthrough and its size.

For the given input of the duration of the current, the intensity of the current, the expected initial temperature, desired final temperature, and material properties of the conductor, the code would output the necessary conductor diameter. For this model, a few assumptions were made. First it was assumed that there would be no heat dissipation. This is not necessarily accurate, but there was no real benefit to factoring it in. It may have allowed for the use of a smaller feedthrough, but the calculations would be more involved. Even though the current through the conductor is dynamic and impulsive, it was assumed to remain constant at the peak value. Again more accurate analysis would not have been beneficial. Lastly the current was assumed occur for three times that of its anticipated duration. These overestimations were considered to be enough to compensate for any sources of error in analysis or fabrication. The initial temperature was assumed to be room temperature, or 20°C. The final temperature was varied.

To keep material costs down, a smaller diameter would be preferred. To allow the feedthrough to reach a temperature greater than 60°C, the PVC would have to be thermally insulated from the feedthrough. This could be done making the hole for the feedthrough larger than the feedthrough and filling the gap with epoxy. However, when trying to build a test apparatus with this configuration, it was difficult to assemble. Even if this design worked, the probability of success in assembling the final chamber would be minimal. Based on this, it was decided to size the diameter of the feedthrough based on having it reach a maximum temperature of 60°C. For heat to transfer, the temperature of the PVC would have to be less than the feedthrough. So if the feedthrough is designed for reaching 60°C, the temperature of the PVC could never go above that. This would require a copper rod or aluminum rod. These sizes were rounded up to the nearest commercially available diameter. Therefore, the available rod sizes were 1in for copper or 1.5in for aluminum. With these sizes, either would easily fit into 10in PVC pipe. Aluminum was chosen since the cost of the copper was more than four times that of the aluminum.

The feedthroughs need to be accessible for electrically integrating the railgun. Given the diameter of the pipe, the feedthroughs would need to be close to the opening. This would have to be no more than 2ft from the opening to ensure that a person could reach the feedthroughs. The railgun also needs to be able to slide into chamber. The number of connections required would make the feedthroughs either too large to allow the railgun to slide in or make the connectors so far into the chamber that they would be inaccessible. The only way around this is to have some portion of it be removable. This would allow the railgun to slide into the chamber, then have the additional material required for the feedthrough to be added and all connections made. An initial design of this configuration is shown in Fig. 14. It has a cylinder with two threaded holes. This would be epoxied into the vacuum chamber and be a permanent fixture. The other pieces would be threaded and attach to the permanent piece. The railguns compression fittings would interface with the flat face. This design may negatively affect the performance of the railgun. A test will need to be done with the feedthrough connected in lead with the railgun. Until this further testing is completed it will not be integrated into the vacuum chamber system.



**Figure 14. The preliminary removable feedthrough design.**

## V. Fabrication Process

### A. PVC

The PVC was ordered as a 20 foot section of pipe. Also, the 10 inch Wye-bell fitting was ordered as well. The first task to accomplish was the cutting of the PVC into two 10 foot sections of pipe. One section would be used as the main body of the vacuum chamber, while the other would be used for various end fittings on the Wye-bell, as well as a source for contingency PVC. All cutting of the PVC was performed in the Hangar workshop, using the horizontal band saw. We deemed this to provide us with a “clean enough” cut to successfully apply the L-gaskets to ensure a smooth interface with the Plexiglas endplate. All PVC pieces were integrated using PVC glue to chemically adhere the components together. To assist in leak prevention all joints were epoxied.

### B. Plexiglas Endplates

The acrylic Plexiglas came in a sheet measuring 12” by 36“. This would make three 12” by 12” plates. The acrylic required very special care when cutting it to the specified design, because acrylic is prone to melting or cracking if it is machined too quickly. A table saw was used to cut the acrylic into the three square plates. Then, using special acrylic drill bits, a drill press was used to drill the pattern of holes.

### C. Aluminum Blocks

The blocks came in a six foot long rectangular stock with a square inch cross-section. This had to be cut into 24 pieces, each measuring about two inches in length. Because it was not stringent that each piece be exactly two inches in length, a horizontal band saw was used to make quick, albeit inaccurate, cuts of the aluminum. Next, holes measuring 0.4375” in diameter had to be drilled through the center of each block. Again, the drill press was employed for this purpose. Once each block was machined properly, we could integrate each one to the chamber body. Each block was mounted to the chamber using JB Weld high strength epoxy. The position of each block was determined using the same design template used to drill the holes into the acrylic.

## VI. Operating Procedure

Given the design and layout of the vacuum chamber, the following describes the anticipated operational procedure.

### A. Initial Set Up

- 1) Place the vacuum chamber onto the test stands and secure the vacuum chamber to them. This is done by lifting the entire chamber and setting onto the test stands. The securing straps are then pulled across the chamber and bolted to its connector.
- 2) Inspect the chamber for any dust, debris, or damage that may have occurred during storage.
- 3) Install the Plexiglas cover for the view port end. This is done by pressing the Plexiglas firmly against the L gasket. Each of the 8 6in bolts is then placed through the aluminum blocks and Plexiglas with the threaded portion on the Plexiglas side. The bolts are then tightened in a criss-cross pattern with wing nuts and neoprene washers.
- 4) Roll the pump into position and connect it to the vacuum pump interface. This is done by lining up the pumps piping with the pump interface on the chamber. A 2in diameter piece of vinyl tubing is placed over the pump interface and the pumps piping. Two hose clamps are then used to tighten the vinyl tube to pump piping and to the pump interface.
- 5) All other possible external connections to the vacuum chamber should be done at this point. This is to prevent disturbing any components after they have installed inside the vacuum chamber.

### B. Target End

- 1) Install break screens. This is done by connecting them to their rail interface. Then the Break screen connectors will be connected to the break screens and their feedthroughs. Once the electrical connections are completed, the break screens will be slid into position and secured.
- 2) A connectivity test should be done to ensure that the break screen connectors were not disconnected during installation.
- 3) Install the target, if there is one. This is done by connecting the target to its rail interface. It would then be slid into position and secured.
- 4) Install the catching mechanism. This is done by connecting the catching mechanism to its rail interface. It would then be slid into position and then secured.
- 5) Install the Plexiglas cover for the target end. This would be done using the same procedure as previously mentioned in step 3 of the ‘Initial Set Up’.

### C. Railgun End

- 1) Install the Railgun. This is done by connecting the railgun to its rail interface. The railgun electrical connectors would be connected to the railgun, but not the feedthrough. The railgun would then be slid into position and secured.
- 2) Install the removable portions of the feedthrough. This is done screwing the removable portion of the feedthrough into the permanent portion of the feedthrough.
- 3) Connect the railgun electrical connectors the feedthroughs. This is done by tightening the compression fitting on the feedthroughs.
- 4) Install the Plexiglas cover for the target end. This would be done using the same procedure as previously mentioned in step 3 of the 'Initial Set Up'.

After all of the components have been installed and the vacuum chamber sealed, the system is now ready to be pumped down to the desired vacuum level.

## VII. Test Results

After the vacuum chamber was assembled its vacuum capabilities were tested. It needed to be able to reach below 100 Torr and remain there long enough for the rail gun operation. To test this, the vacuum chamber was connected to a pump with 1ft of PVC pipe. A convectron gage was place in the PVC pipe to test the vacuum level between the pump and the chamber. The vacuum was turned on and ran until the readings on the convectron gage leveled off. The pump was then turned off to see how well the system help vacuum. Table 4 shows the results of the test.

Time	Vacuum Level (Torr)
1	55
2	60
3	62
4	66
5	69
6	73
8	85
11	100

After the readings were taken, a noticeable leak was found. For future use this should be sealed to obtain better results. Even with the leak however, the vacuum chamber was able to satisfy its requirements.

## VIII. Conclusion

This report has discussed the design and assembly process of a low cost vacuum chamber capable of supporting the operation of an electromagnetic railgun to simulate impacts in space. The vacuum chamber was constructed out of 10in diameter 10ft PVC pipe with a Wye fitting for viewing the target during impact. The chamber was designed to support a 6.5in X 6.5in X 60in railgun. . The vacuum chamber feedthroughs were designed to be able to carry 1-2Mamps at 8kV to the railgun. The vacuum chamber was also designed to reach a vacuum pressure of less than 100 Torr. The vacuum chamber was successfully able to reach a pressure of 50 Torr, and remain below the 100 Torr mark for 11 minutes. This was all accomplished for \$1325. This figure only considers the money spent on the project. It does not include borrowed or donated equipment. If all products utilized in this project had been purchased, the cost would have been significantly higher. To progress this project further, the rail system would need to be manufactured and the high power feedthrough and catching mechnasim would need to be tested. Convectron gages were not placed in the vacuum chamber for the initial test because it would involve tapping threads into the PVC of the chamber. Future testing will require multiple gages to better understand the pressure distribution throughout the vacuum chamber. Also testing would need to be done with the railgun in the chamber to verify the system as a whole.

## Appendices

### Appendix A: Cost Breakdown

Item	Cost (USD)
10" Dia SCH80 PVC, 20' long	346
10" Dia SCH80 PVC Wye-Bell Fitting	572
12"x36" Plexiglas Sheet	70
1 square inch 6061 Aluminum stock, 6' long	50
1.5" diameter 6061 Aluminum stock, 3' long	35
10.75" L-gasket (x3)	90
3/8" by 6" bolts (x24)	25
3/8" Neoprene Washers (x24)	14
Wing nuts (x24)	10
Epoxy	20
PVC Glue and Primer	20
Burro Brand	72
<b>TOTAL</b>	<b>1325</b>

## Appendix B: Matlab Code

```
% Andrew Bothwell
% Senior Project
% Vacuum Chamber Calculations

% This script was developed to perform various trades on PVC schedule
% selection as well as aid in sizing pipe and Plexiglas structures. Some
% failure analysis was also performed to ensure structural rigidity.

% Previous research has shown that PVC has been used on chambers that drop
% as far down as ~25 Torr. Analysis has shown that our vacuum chamber could
% theoretically pull a full vacuum.

clc
clear all
%% General Vacuum Chamber Characteristics

ID = 9.493; % inner diameter, inches
OD = 10.75; % outer diameter, inches
t = .593; % thickness sch 80, inches
l = 14*12; % chamber length
t2 = .365; % thickness, sch 40
SA = 2*pi*(ID/2)^2+2*pi*(ID/2)*l; % surface area of cylinder
CSA = pi*(OD^2-ID^2); % cross-section area of pipe, in2

torr = (0.0193367747)^-1; % torr/lbf

P_int = linspace(14.6-(100/760)*14.6,14.6,1000); % internal pressure, psi

%% Stresses on Chamber Walls
P = torr*P_int;
sigma_1 = P_int.*(ID/2)/t; % hoop stress for SCH80, psi
sigma_2 = P_int.*(ID/2)/(2*t); % longitudinal stress for SCH 80, psi
s1 = P_int.*(ID/2)/t2; % hoop stress for SCH40
s2 = P_int.*(ID/2)/(2*t2); % longitudinal stress for SCH40

%% PVC SPECS
max40 = 140*(ID/2)/t2; % max hoop stress of SCH40
max80 = 230*(ID/2)/t; % max hoop stress of SCH80

s_max40 = linspace(max40,max40,1000); % Yield stress of SCH40
s_max80 = linspace(max80,max80,1000); % Yield stress of SCH80

figure(1)
plot(P,s1,P,sigma_1,'LineWidth',3)
% hold on
% plot(P,s_max40,'--',P,s_max80,'--','LineWidth',4)
% hold off
legend('Hoop Stress SCH 40','Hoop Stress SCH 80')
xlabel('Internal Pressure, Torr')
ylabel('Wall Stress, psi')
grid on
```



```

%% Varying Pipe Diameter

s_8 = P_int.*(7.565/2)/.5;
s_10 = P_int.*(9.493/2)/.593;
s_12 = P_int.*(11.294/2)/.687;
s_14 = P_int.*(12.41/2)/.750;

figure(2)
plot(P,s_8,P,s_10,P,s_12,P,s_14,'LineWidth',3)
xlabel('Internal Pressure, psi')
ylabel('Max Stress, psi')
legend('8in Diameter','10in Dia','12in Dia','14in Dia')
grid on

%% Stress on End Caps and Pipe Ends
% For a flat plate end cap, this equation is used  $t = C*D*\sqrt{P/\sigma}$ 
% where t = thickness
% C = coefficient (this number changes, depending on the shape)
% P = pressure
% sigma = maximum allowable stress

ends_sigma = OD^2*P_int.*(0.55^2)/(1^2);

% for the pipe end
F_pipe = P_int.*pi*(ID^2); % Force on the pipe end
sigma_pipe = F_pipe./(pi*((OD/2)^2-(ID/2)^2)) % Stress on the pipe

figure(3)
plot(P,ends_sigma,'LineWidth',3)
xlabel('Pressure, Torr')
ylabel('Maximum Stress, psi')
legend('Plexiglas Stress')
grid on
figure(4)
plot(P,sigma_pipe,'LineWidth',3)
xlabel('Pressure, Torr')
ylabel('Maximum Stress, psi')
legend('PVC Stress')
grid on

%% Bolt Sizing For End-Caps

% n = 8; % number of bolts
% F_bolt = F_ends./n; % Force on each bolt, lbf
% r_bolt = linspace(.5*1/8,.5*.5, 1000); % radius of each bolt
% A_bolt = pi*(r_bolt.^2); % Cross section area of each bolt
% sigma_bolt_nec = sigma_2./n; % necessary stress in each bolt
% sigma_bolt_act = F_bolt./A_bolt; % tensile stress in each bolt

% figure(4)
% plot(r_bolt,sigma_bolt_act,r_bolt,sigma_bolt_nec)
% xlabel('bolt radius, inch')
% ylabel('Bolt Stress, psi')
% legend('Actual Bolt Stress','Necessary')
% grid on

```

```

% figure(5)
% plot(torr*P_int,F_walls,torr*P_int,F_bolt)
% legend('F_w_a_l_l_s','F_b_o_l_t_s')
% xlabel('Chamber Pressure, Torr')
% ylabel('Loads on Chamber Walls, lbf')
% grid on

clear all
close all
clc

To = 20; %(C) Initial temperature
Tf = 20+1:100; %(C) Final desired temperature
I = 4e5; %(A) Current of pulse (assumed constantly held at max - huge
overestimation)
dt = 1e-3; %(s) Time span of pulse
%% Copper Properties
Cvp = 3.45; %(J/(K-cm^3)) Volumetric heat capacity of copper
rho_p = 0.0171; %(ohm-mm^2/m) resistivity of copper
Cvp = Cvp*100/1000; %(J/(K-mm^2-m)) Volumetric heat capacity per unit length
%% Aluminium Properties
Cva = 2.422; %(J/(K-cm^3)) Volumetric heat capacity of aluminium
rho_a = 0.0282; %(ohm-mm^2/m) resistivity of aluminum
Cva = Cva*100/1000; %(J/(K-mm^2-m)) Volumetric heat capacity per unit length
%% Diameter
Anp = sqrt(I^2*rhop*dt./(Cvp.*(Tf-To))); %(mm^2) required cross sectional
area to stay within desired final temperature
Danp = 2*sqrt(Anp/pi)/25.4; %(mm) required radius of a suitable cable

Ana = sqrt(I^2*rhoa*dt./(Cva.*(Tf-To))); %(mm^2) required cross sectional
area to stay within desired final temperature
Dana = 2*sqrt(Ana/pi)/25.4; %(mm) required diameter of a suitable cable
Dp=interp1(Tf,Danp,60);
Da=interp1(Tf,Dana,60);
%% Plots
plot(Tf,Danp,'b')
hold on
plot(Tf,Dana,'r')
title('Feedthrough Size Based on Final Temperature')
legend('Copper','Aluminum')
xlabel('Temperature (^oC)')
ylabel('Diameter (in)')

```

## Acknowledgments

First and Foremost we would like to acknowledge Dr. Kira Abercromby. Her guidance was invaluable in the creation of this project. We would also like to acknowledge Max Glicklin for his persistent interest in our project and his willingness to help us without hesitation nearly every step of the way.

## References

<sup>1</sup>Independent Pip and Supply, Corp., *PVC Physical Properties and ASTM Standards for Fittings*, URL: [http://www.indpipe.com/images/PDF/pvc\\_cpvc\\_physical\\_properties\\_and\\_astm\\_specifications\\_for\\_fittings.pdf](http://www.indpipe.com/images/PDF/pvc_cpvc_physical_properties_and_astm_specifications_for_fittings.pdf) [cited 5 June 2012].

<sup>2</sup>Harrison Machine & Plastic Corporation, *Schedule 40/80 PVC Pipe and Fitting Specifications & Pipe Sizes & Dimensions*, URL: <http://harrisonplastic.com/pvcschedule40-80specs.html> [cited 6 June 2012].

<sup>3</sup>Kayson's Akrylik, Furniture and Accessories, *Physical Properties of Acrylic Sheets*, URL: <http://www.kaysons.in/acrylic/physicalproperties.pdf> [cited 5 June 2012].

<sup>4</sup>Nash, David H., "The Companion Guide to the ASME Boiler and Pressure Code," *Chapter 52: UK Rules for Unfired Pressure Vessels*, URL: [http://www.krrao.com/images/Chapter\\_51\\_pp285-308\\_KRs\\_Notations\\_per\\_NASH\\_UPDATES\\_of\\_3-26-08.pdf](http://www.krrao.com/images/Chapter_51_pp285-308_KRs_Notations_per_NASH_UPDATES_of_3-26-08.pdf) [cited 6 June 2012]