

# SENIOR PROJECT FINAL REPORT



## BLUEBEATS

( [www.BlueBeatsAudio.com](http://www.BlueBeatsAudio.com) )

California Polytechnic State University  
San Luis Obispo, CA  
Computer Engineering Department

**By:**  
BlueBeats Audio

Aaron Martinez  
Jake Muir  
Mishal Shah  
Richard Wissemann

**Advisor:**  
Dr. Hugh Smith

May 16, 2012

# Table of Content

<b>1. Introduction</b>	<b>3</b>
<b>2. Problem Description</b>	<b>5</b>
<b>3. Related Products</b>	<b>6</b>
<b>4. Business Related Work</b>	<b>8</b>
<b>5. Design</b>	<b>10</b>
5.1 Hardware	10
5.2 Software	11
<b>6. Implementation</b>	<b>13</b>
6.1 Hardware	13
6.2 Software	16
<b>7. Testing</b>	<b>17</b>
<b>8. Problems Encountered</b>	<b>18</b>
8.1 Hardware	18
8.2 Software	18
<b>9. Prototype</b>	<b>20</b>
<b>10. Future Work</b>	<b>23</b>
<b>11. Lessons Learned</b>	<b>24</b>
<b>12. Cost Analysis</b>	<b>25</b>
<b>13. Work Cited</b>	<b>27</b>
<b>14. Appendices</b>	<b>28</b>
14.1 Appendix A: Patent Application	28
14.2 Appendix B: SPP commands	41
14.3 Appendix C: BlueBeats Non-Disclosure Agreement	42
14.4 Appendix D: Innovation Quest	46
14.5 Appendix E: Level 2 Design	50
14.6 Appendix F: BlueBeats Overview Diagram	50
14.7 Appendix G: RFCOMM connection	51
14.8 Appendix H: Solidworks Drawings	52

# 1. Introduction

Our group's senior project is called BlueBeats. The BlueBeats product was created in order to provide a wireless audio gateway between Bluetooth enabled devices. Users of BlueBeats can use an Android or computer application to interface with the BlueBeats device. The Android and computer applications allow the user to easily scan for devices, add/remove devices from their personal list, and pair/connect with a selected Bluetooth enabled device. Once the user is connected to the BlueBeats device, he/she has two options. The first option occurs when the user connects the BlueBeats device to a device with speakers (using 3.5mm audio jack or RCA cable) which will allow the user to wirelessly transmit audio to the BlueBeats device so it can be played through the device's speakers. The second option occurs when the user connects a TV to the BlueBeats device (using 3.5mm audio jack or RCA cable) and chooses to wirelessly (using Bluetooth) connect the BlueBeats device to a headphones Bluetooth device. This allows the user to wirelessly transmit the audio from the TV to the user's Bluetooth enabled headphones. As a result, BlueBeats gives users more flexibility with audio applications by allowing users to wirelessly transmit audio from their phone to a device with speakers or from a device with speakers to a pair of Bluetooth enabled headphones.

The software for both the Android and computer applications were written in Java. The Android application uses the public Bluetooth APIs in order to make the connection between the phones and BlueBeats. The computer application uses the Bluecove Bluetooth APIs in order to make the connection between the computer and BlueBeats. Both applications contain the same options for the user and follow the same layout in order to increase the usability of both applications for the user. Additionally, both applications hide a lot of the complex Bluetooth functionality from users so that they just have to select devices they want to add to their personal list and then select a device from their list that they want to connect to.

The hardware consists of a WT-32 BlueGiga chip that is used to communicate with the microcontroller board in order to play and receive audio. The design for the microcontroller board was created using the Eagle software. The microcontroller board and the WT-32 chip is placed inside an enclosure that keeps all of the hardware out of sight and keeps all of the delicate parts of the circuit board properly contained. The enclosure for the hardware is 2.6 inches by 2.5 inches and it has holes for the buttons, LED lights, and the audio jack. There are 3 LED lights that include one for power, one for bluetooth connection, and one if the battery needs charging. The four buttons consists of play/pause, next song, volume up, and volume down.

Our team decided to further develop our project into a company after graduating. Since the team consists of only technical students, we had to learn the business side of our project on our own. We were able to see a glimpse of the business aspect through the resources that Cal Poly provides. The resources that were the most useful were the Center for Innovation and Entrepreneurship (CIE) and the Student Startup Assistance Team (SSAT). We were given useful information about the basic process of starting a company, and how to setup a vision that the company could follow. We were also able to draft a provisional patent application from the resources that we received through the CIE.

The original estimated cost for the BlueBeats was based on two main items for development, the Arduino Uno (\$30) and Bluetooth chip WT-32 (\$60), which is turns out to be around \$90. The final cost for our senior project was \$732.74 with the hardware development cost being \$252.44. The most expensive part of our senior project was creating five BlueBeats devices using the 3D prototype printer and our own circuit board. At the end of our project, each BlueBeats device cost was cut down to a cost of \$96.06.

## 2. Problem Description

There are currently two common audio problems that exist today. First, there is no easy way for common devices to play audio that accommodates both the needs of user with impaired hearing and normal hearing in the same room. As an example, if there are users with normal hearing in a room, then there is no simple and inexpensive way for a user with impaired hearing to listen to the TV in the same room. By connecting BlueBeats to the TV, it allows the person with impaired hearing to still be present in the room because BlueBeats can transmit the audio from the TV to Bluetooth headphones that a hearing impaired user can wear. As a result, the user with impaired hearing can be listening to the same TV at a volume that suits them without having to disturb any other users in the room. Second, there is not an easy and inexpensive way for user to transmit audio to a speaker system in their home. As an example, if a user is at an event and the user wanted to play music from their smart phone to some speaker system, the user would have to keep their mobile phone plugged in directly to the speaker system the whole time. This poses a risk to the user because unless the user stands next to the speaker system the whole time, it is possible for the mobile device to get stolen. Additionally, a user has to walk to a speaker system every time they want to change the volume, song, or playlist. However, connecting BlueBeats to a speaker system will convert the system into a wireless audio system that will allow a user to keep their phone on their person at all times while still playing music from the speaker system.

### 3. Related Products

There are many devices that are used to connect with a Bluetooth device to produce part of the features that our product is doing. This section will discuss these technologies.

Product Name	Bluetooth	A2DP	Headphones	NFC	Battery	Cost
BlueBeats	Yes	Yes	Yes	No (But Possible)	Yes	\$70
BlackBerry Music Gateway	Yes	Yes	No	Yes	No	\$50
Logitech Wireless Speaker Adapter	Yes	Yes	No	No	No	\$39.99
Belkin Bluetooth Music Receiver	Yes	Yes	No	No	No	\$49.99
Miccus BluBridge Mini-Jack RX	Yes	Yes	No	No	Yes	\$39.88
Miccus BluBridge Mini-Jack	Yes	Yes	Yes	No	Yes	\$39.88
Sony HWSBTA2W	Yes	Yes	No	No	No	\$79.99

**Table 1: Comparing Related Products**

#### *BlackBerry Music Gateway*

This device is the latest in gadgets that uses Bluetooth technology to pair with a cell phone or tablet to stream music to your home audio system. One advantage that this technology has over others is the use of Near Field Communication (NFC) technology[1]. This allows a device to hover over the Music Gateway and automatically make a Bluetooth connection. This device can be connected using either a 3.5mm auxiliary input jack or an RCA auxiliary input jack[2].

Also, the NFC technology only works with NFC-enabled BlackBerry devices[4], which are currently limited in the US market. The current price for this device is \$50.

### *Logitech Wireless Speaker Adapter*

The Logitech Wireless Speaker Adapter is very cost effective at \$39.99[5]. A disadvantage about this device is that it does not have a battery component to it. This device must be plugged into a wall outlet at all times so it can be inconvenient for the user because the he/she must make sure that the speaker system is near an available wall outlet. This device also uses Bluetooth technology to allow the user to transmit music from their mobile device to the speaker system.

### *Belkin Bluetooth Music Receiver*

The Belkin Bluetooth Music Receiver is another product on the market that is very compact and discrete. According to the product's website, it is also compatible with Apple products, such as iPhones and iPod touch [6]. Aside from being compatible with Apple products, it also works with any A2DP device. This device is able to transmit up to 33 feet away, and is able to remember up to six paired devices. The cost for this device is \$49.99.

### *Miccus BluBridge Mini-Jack RX*

This device receives music, through Bluetooth, from a smartphone, iPod, PC, MacBook or laptop. The Mini-Jack RX works with any phone or device that can transmit over the Bluetooth A2DP profile. This device, unlike the previous two devices discussed above, is rechargeable and does not need to be connected to a power outlet. This feature makes the device flexible and can be used with any device that contains an audio input. The cost of this device is \$39.88 [7].

### *Miccus BluBridge Mini-Jack*

This device complement the Mini-Jack RX since it works with any phone or device that is not able to transmit music over the Bluetooth A2DP profile. This device is also rechargeable with 7 hour of playback. The cost of this device is also \$39.88 [8].

### *Sony HWSBTA2W Bluetooth® Transmitter & Receiver*

The Sony Bluetooth device is on the expensive side compared to the other devices we found, with a cost of \$79.99 [9]. However, this device is capable of transmitting and receiving Bluetooth signals unlike the other devices. The Sony device works with other devices that don't have Bluetooth A2DP features and is able to transmit to a Bluetooth A2DP receiving module.

## **4. Business Related Work**

Since the beginning of senior project, our team decided to start a company out of the BlueBeats product. Since no one from our team has had experience in starting a company, we had to find resources that would guide us to this goal. After doing some research, we were able to find various on-campus resources that are beneficial to starting a company. The resources that were the most informative were the Center for Innovation and Entrepreneurship (CIE), and the Student Startup Assistance Team (SSAT). The person that we interacted with for CIE was Jessie Becker, and the person for SSA was Will Newhart.

The first meeting we had was with Jessie Becker and this meeting consisted of discussing the current stage of our project, and deciding our short term and long term goals. Our short term goals consisted of developing our initial prototype, start testing the initial prototype, and if possible start selling our product. Our long term goals were to begin the process of legally starting a company, and doing more research on what other products we could develop using Bluetooth technology. Jessie advised us to hold off on building our device in order to focus on researching the potential customer base. She said that after doing consumer research we would have a better understanding of our customer base, which would allow



us to better design our product for that specific customer base. We carried out this advice by talking to our colleagues about the design of our prototype and asking them to critique it.

During this meeting we also discussed the possibility of patenting our device and how to begin the process of filing a provisional patent application, listed in Appendix A. Her advice was to first do research on prior artwork in order to learn if there were already patents that described what we were doing. This would help us save time and money in writing a provisional patent application. However, when we told her that we wanted to file a provisional patent and that we were hoping that we could use the pro bono lawyer they had available, she seemed hesitant. She did not want us to use their lawyer to only look over our patent. She wanted us to have specific questions or concerns for the lawyer.

Although we were not able to use CIE's pro bono lawyer, Jessie did introduce us to Will Newhart from SSAT. The purpose of SSAT is to help "entrepreneurs develop and refine their business ideas and skills." [10]. We pitched the concept of our product to Will, and we were able to get feedback in regards to our product. Will also advised us to conduct customer research in order to pinpoint our customer base and understand what they wanted. Will also gave us resources that would guide us in the process of creating a plan for starting a company. He advised us to register for Innovation Quest, which we did but , unfortunately, our project was not chosen for the final round. Other resources that we used that were beneficial were the Innovation Quest workshops and Jim Dunning. The Innovation Quest workshop that we attended discussed Intellectual Property (IP), and the role Cal Poly played. In terms of our senior project, Cal Poly did not claim any IP. The only way that Cal Poly would contribute IP would be if we used any extraordinary resources from the school. This was a concern because we wanted to use Cal Poly's rapid prototype machine to build our enclosure. A meeting was set up with Dr. Tom Mase to discuss the role that Cal Poly would have if we used the rapid prototype machine; Dr. Mase referred us to Dru Zachmeyer, Associate Director of Contracts, Procurement and Risk Management. We emailed Mr. Zachmeyer with our concern and he assured us that Cal Poly would not pursue any IP, and we would only use the rapid prototype machine as a paid service.

## 5. Design

### 5.1 Hardware

The hardware design of the BlueBeats audio system consists of an AVR microcontroller, Bluegiga audio Bluetooth module, USB port, four buttons, three LEDs, and a lithium rechargeable battery. The combination of these parts allows the user to play and transmit audio over Bluetooth, control volume and songs, and recharge the battery. Specifically we are using an Atmega32U2 microcontroller because it is the smallest and cheapest microcontroller to fit our requirement specifications. We needed a controller that had 14 GPIO pins, hardware UART, and USB support. The Atmega32U2 operates at 16 MHz clock frequency, allowing the UART connection to operate at a high speed of 250K baud.

Another benefit of the Bluegiga WT32 Bluetooth module is that it has A2DP, AVRCP, and SPP stacks built into its hardware. Each of these protocols is necessary in order to communicate and control the audio connection. GPIO pins on the WT32 module are configured to represent module states, such as Ready, Command, and Data modes. The GPIOs can also be used to indicate if a Bluetooth connection is present. When the battery drops below a certain level, a GPIO is triggered indicating that the unit should be charged. This module also contains input and output audio conversions so we are able to convert analog audio to Bluetooth signals and also use the Bluetooth digital signals to play analog audio. Both directions operate at a sampling frequency of 44,100 Hz.

The AVR microcontroller has a USB interface that allows for programming and USB terminal settings. Four push buttons were placed on the board. Two of the buttons control the audio playback: one for skipping tracks and one to play/pause. The other two buttons control the volume: one for volume up and one for volume down. Three status LEDs are used to signal the state of the device: one for power (on/off), one for a Bluetooth connection (connected/disconnected), and one for battery warning (needs charging/ok). There are two types of modes that the Bluetooth module utilizes. One is Data Mode and the other is Command Mode. In Data Mode any information written to the receive pin of the Bluetooth chip will get transmitted to the paired device. This allows the microcontroller to send/receive information

between the paired devices. In Command Mode any data written to the receive pin of the Bluetooth chip is interpreted by the WT32 module. This allows the microcontroller to switch modes, initialize settings, adjust volume, etc. Both of these modes are utilized in order to automate the system.

The microcontroller code analyzes the UART port for any type of new data. Once data comes in to the system it will break down the string into parts. For example when the Bluetooth chip sends the string “DEVICE battery” the first keyword analyzed is “DEVICE”. This means that this information is being requested from the paired device. The second keyword is “battery” and this means that the paired device wants to know what the battery level is. From there the microcontroller will tell the Bluetooth chip to enter command mode, query the battery voltage, and then return back to data mode. Once the Bluetooth chip has finished the battery inquiry it will transmit the command “BATTERY XXXX” where “XXXX” is the voltage in millivolts. When the keyword “BATTERY” is read, the system knows that this is a response from the battery inquiry. The microcontroller is then programmed to send the command in Data Mode (to the paired device) “BlueBeats BATTERY XXXX” so that the user can see what the status of the battery is. The response time of this whole inquiry is about 100ms, which is almost unnoticeable to humans.

## **5.2 Software**

The flowchart below describes the software design of BlueBeats. When the application first runs, it checks that Bluetooth is enabled in the device. If Bluetooth is enabled then the application will send the user to the main screen. However, if Bluetooth is not enabled then the application will tell the user to manually enable the Bluetooth feature. From here, there are two possible scenarios that can occur. The first scenario is that the user will not enable Bluetooth, which at this point the application will terminate. The second scenario, and the most likely, is for the user to enable BlueBeats, which the application will then go to the main screen. Now in the main screen, the user may be able to pair to or remove any device that is listed. However, if no device is listed then the user will scan for devices by pressing the ADD

button. The application will now scan for other Bluetooth-enabled devices. The user is now able to select a device from this list and add it to the main screen to be paired with. When a user successfully pairs with a device, the user is able to select whether he or she wants to do an A2DP connection or if he/she wants to connect to a Bluetooth-enabled headphone system. If the user chooses an A2DP connection, then he or she is now able to transmit music from a smartphone or personal computer. To do this, the user can exit out of the BlueBeats application and then go to his or her favorite music player to play music. However, if the user chooses the headphone option then the application will scan for Bluetooth-enabled headphones to connect to. This process tries to minimize the confusion for a user that is using the application.

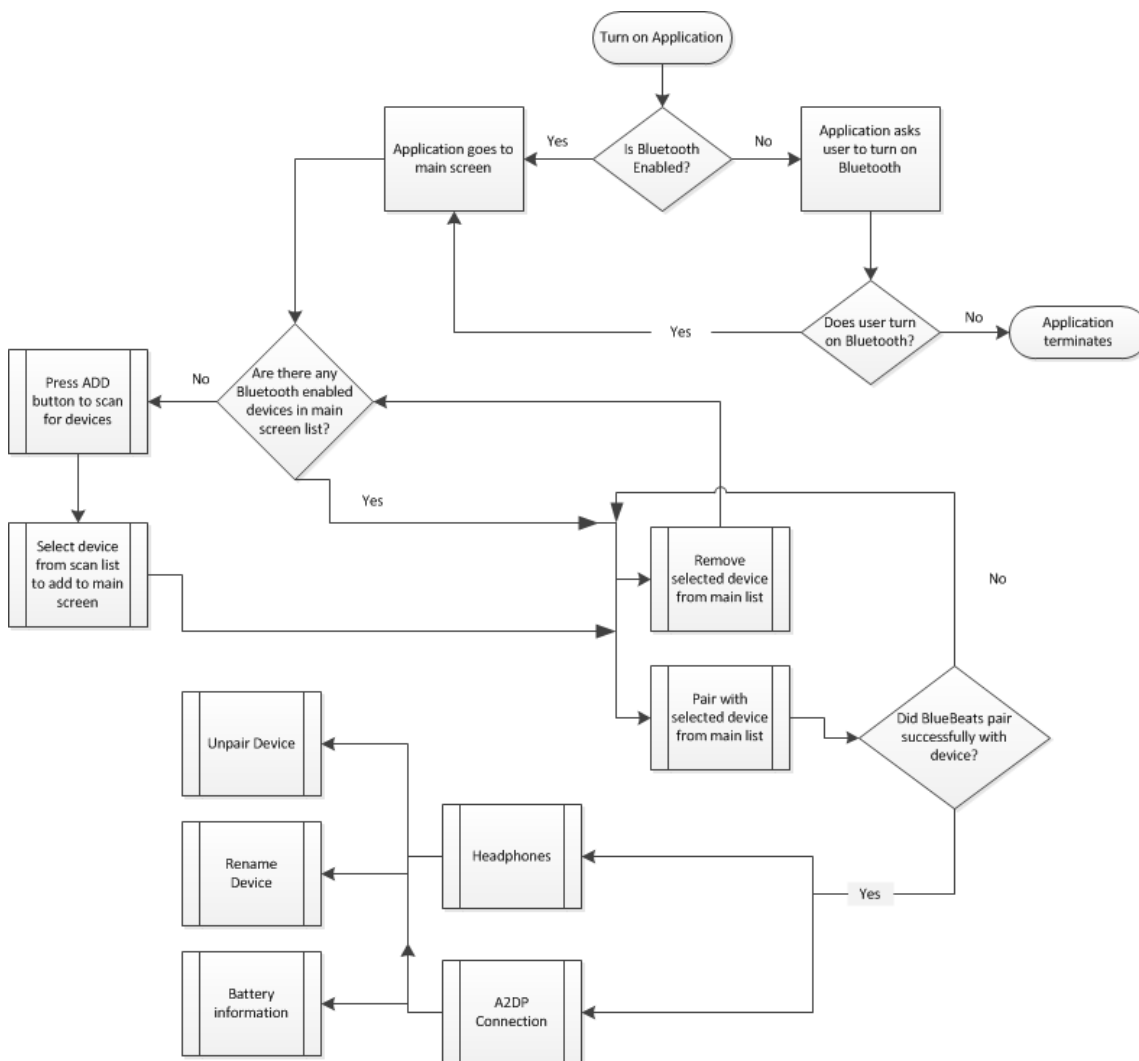

**Figure 1: Software Flowchart**

## 6. Implementation

### 6.1 Hardware

When we started this project we needed to conduct some hardware research in order to find out which GPIO pins we needed and how to use UART effectively for our project. We bought breakout boards for both the Atmega32U2 and the WT32. This allowed us to connect any of the pins to any of the other ones in order to find the correct implementation. We found out that the baud rate is most efficient at 250k baud because the clock evenly divides into this frequency generating a 0% error. We found that all of the other baud rates ended up producing intermittent data errors.

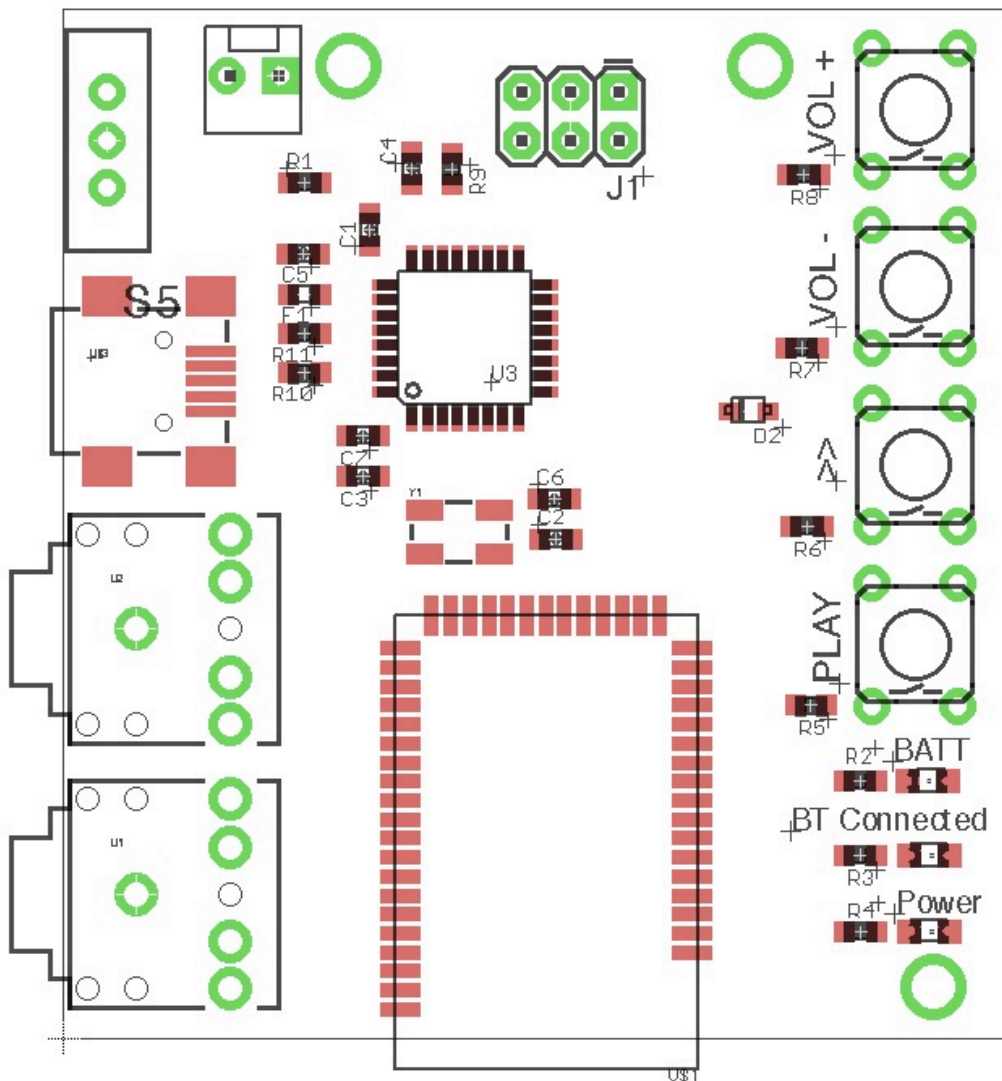

Figure 2: Layout of BlueBeats Board

Once the wires were correctly connected to each other we created wiring schematics with Cadsoft Eagle software. The schematic combined all of the hardware design onto a single board. Headphone jacks were wired to both the input and output ports of the WT32 module. GPIOs between the Atmega32U2 and WT32 were connected. USB charging port was connected to the lithium charging circuit. Figure 1 in the appendices is the schematic for the BlueBeats board.

The board layout also used the Cadsoft Eagle software. The finished board layout came out to be 2"x2" in size. Figure 2 in the appendices shows the board layout for BlueBeats.

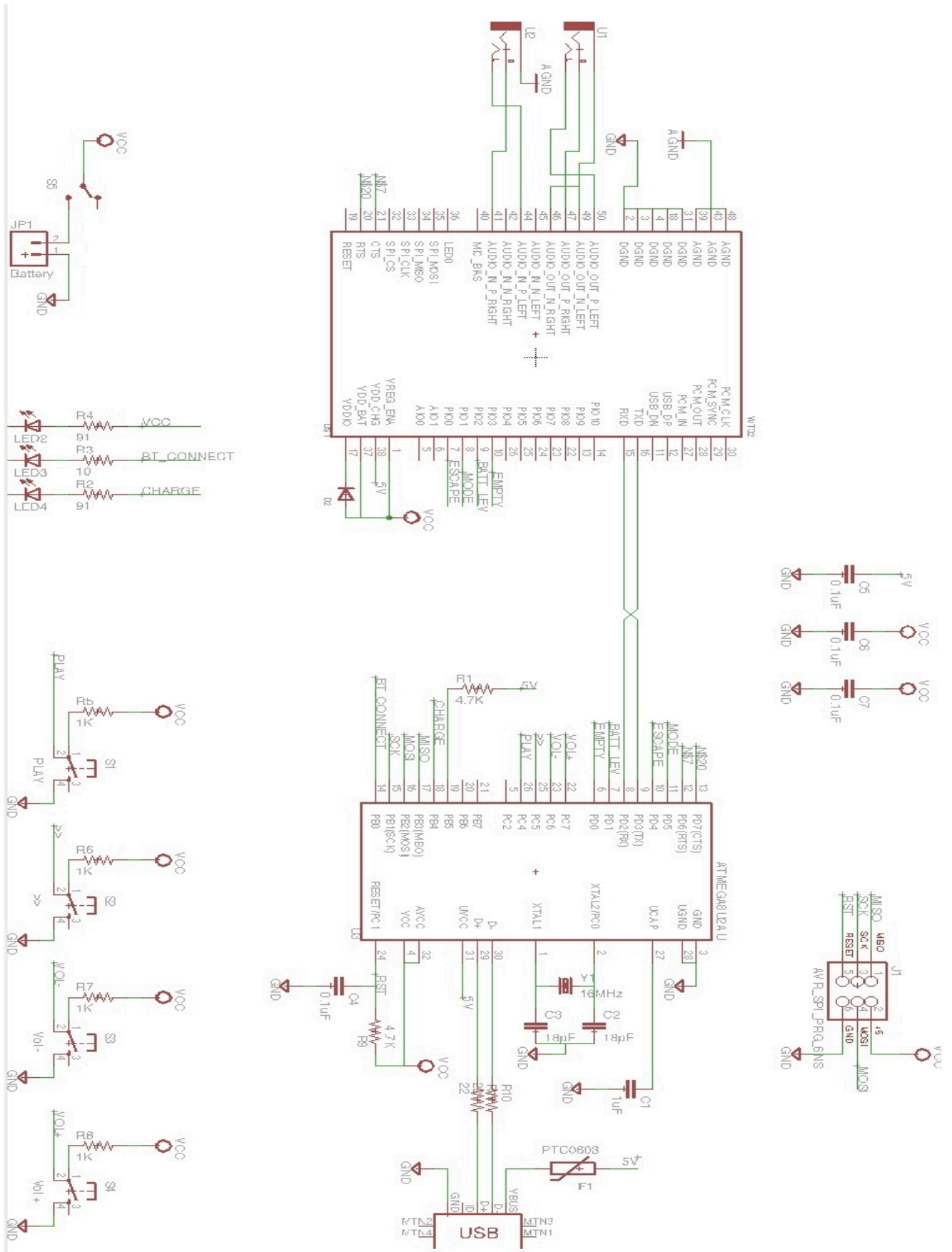

Figure 3: Hardware Schematic Layout

## 6.2 Software

The implementation for the Android app is split into Model classes and View XML files. The model classes consist of BlueBeatsActivity, BlueBeatsDeviceScan, BlueBeatsDeviceScanHeadphones, BlueBeatsDeviceService, BlueBeatsRenameScreen, ConnectThread, Device, and DeviceArrayAdapter. BlueBeatsActivity contains the code for the main screen of the android application. It contains buttons for each of the operations available to the user and the options toggle grayed out/colored depending on what actions are currently available to the user. The BlueBeatsActivity class also keeps track of a device list for the user which is populated when the app starts up with the devices previously added by the user. This device list contains checkboxes so the user can select one or multiple devices.

The BlueBeatsDeviceScan class contains the code for the device scan popup window. The popup window scans for available Bluetooth devices within range of the user's phone. To improve the window's readability, the available Bluetooth devices are split up into new devices and currently paired devices. When the user selects a device from the scan list it is added to the device list on the main screen. The BlueBeatsDeviceScanHeadphones class contains the code for the headphones device scan popup window. The popup window scans for available headphone Bluetooth devices within range of the user's phone. Like the BlueBeatsDeviceScan class, the headphone devices are split up into new headphone devices and currently paired headphone devices in order to improve readability for the user. When the user selects a headphone device from the scan list it is added to the device list on the main screen. The BlueBeatsDeviceService class does all the work required for setting up and managing Bluetooth connections with other devices. It contains three threads that each have a specific function: a thread for connecting with a device, a thread that listens for incoming connections, and a thread that performs data transmissions once it is connected.

The ConnectThread class creates the connection between the android phone and the Bluetooth device. These threads are used by the BlueBeatsActivity class to first pair with a target device and then setup a connection with it. The Device class is wrapper class for the BluetoothDevice class provided by



the Android APIs. It contains a BluetoothDevice variable to represent a specific remote Bluetooth device and a Boolean that shows whether the device is currently selected or not. This class is used by the DeviceArrayAdapter to create the list of devices on the main screen, device scan popup window, and headphone device scan popup window.

The DeviceArrayAdapter class contains the implementation for the device list used by the main screen, device scan window, and headphone device scan window. It extends Java's ArrayAdapter class and handles all the operations for the device list such as add, remove, select, and unselect. The class also controls the view for the class which dictates the UI for the list through the checkboxes and list items. For an android application, the view files are implemented through XML files instead of Java classes. The main.xml file defines the UI layout for the main screen of the android application. The device\_list.xml file defines the UI layout for the device scan popup window and the headphone device scan popup window. Finally, the list\_device.xml file define the UI layout for adding/removing devices to/from the user's device list.

## **7. Testing**

The testing conducted on BlueBeats consisted of JUnit tests for each method in each of the model classes for the android application. Additionally, all of the group members participated in user testing of the BlueBeats app once its functionality was complete. The software testing of the BlueBeats application helped us solve many functional and usability problems with the app by allowing us to reiterate over our development process.

## **8. Problems Encountered**

### **8.1 Hardware**

When we initially hooked up the microcontroller to the WT32 we were having a very hard time communicating with the device. We found out that the default baud rate for the WT32 Bluetooth module is 115k baud, which has a very high error rate with our 16Mhz clock. We configured the UART to operate in 2x speed mode allowing us to reduce the error a small amount in order for us to properly send a command to change the baud rate of the WT32 module.

The headphone wiring was extremely ambiguous from the datasheet so in order to find the best sounding connections we needed to try several combinations of groundings and differential routing wirings. We found that the ground from the headphones sounds best connected to the negative differential pair of the left and right speakers, while the audio input jack sounds best by connecting the input ground to the audio ground of the WT32 module.

In order to control the Bluetooth AVRCP audio and also maintain a Serial Port Protocol connection I needed to “select” each one individually. They both operate in Data Mode. Fortunately the AVRCP only writes to the connection so we did not need to poll for that connection. When a button is pressed the WT-32 chip switches selects the AVRCP data channel submits the AVRCP audio command and then returns to the previous mode (either Command Mode or the SPP Data Mode).

### **8.2 Software**

One software problem we encountered was making a Bluetooth A2DP connection from an android phone to another Bluetooth device. Unfortunately, for the current API versions supported by android phones do not include their Bluetooth APIs. Although android has some documentation on Bluetooth profile classes, the Bluetooth APIs are hidden. We tried several different ways of trying to access and use the hidden Bluetooth APIs but they required jailbreaking your phone or going through an extremely difficult and tedious process of extracting the APIs from your phone’s android SDK. Another software

problem we encountered was ending the connect thread early if another device is currently connected to the Bluetooth device we are trying to connect to. If a user tried connecting to a Bluetooth device that was already connected to a different device, the android app would stay in the connect loop endlessly trying to connect to the device (which is impossible while it is connected to another one). Although it took a little while to solve we figure out how to detect if the target Bluetooth device was already connected to another device. Now if this event is detected, then the app will immediately stop trying to connect to the target device.

On the computer application side, the main problem that was encountered was trying to make an RFCOMM connection with BlueBeats. After doing further research, we figured out that the correct url for a connection is `btspp://00078044DB0A:1`". `btspp` means that the device will try to make a Serial Port Protocol Connection, which is the same as an RFCOMM connection. `00078044DB0A` is the address of the device, in this case BlueBeats, and `1` being the port number for SPP connection.

Other

In terms of our patent and being able to complete it, when we tried to get the pro bono lawyer from CEI, they seemed hesitant for us to meet with him. While we wanted someone with experience in provisional patent applications to help us review our application, Jessie from CEI instead wanted us to come up with specific question that we had. She felt that if we only asked for the lawyer to review our application, then he would want to completely draft our whole application, which is not what was to the best interest of CEI.

## 9. Prototype

The 3D rapid prototype was created at Cal Poly's Mechanical Engineering department, which was created at discounted price. The prototype consisted of three components: the top case, bottom case, and the buttons case. The top and bottom case are held in place by four screws which are shown in Figure 4. This figure also displays the top case, which includes openings for the button case and the LED lights. The LED light holes are created with walls between each LED that prevent light from bleeding into each other. Also, the goal of the LED dividers is to reflect light of the wall to create a stronger light brightness. The backside of the top case has four openings for an on/off switch, Mini USB and two audio head jacks. Figure 5 shows the buttons on the top case, which are the Play/Pause, Forward, Volume Up, and Volume Down buttons. These buttons could only be used during the streaming music from a smartphone. The enclosures for the buttons will be created as one part and will later be cut into four individual buttons. The Bottom case of the BlueBeats has mounting bars, which will hold the circuit board in place, as shown in Figure 8. The Battery for BlueBeats will be placed under the circuit board, which will help keep the device compact.

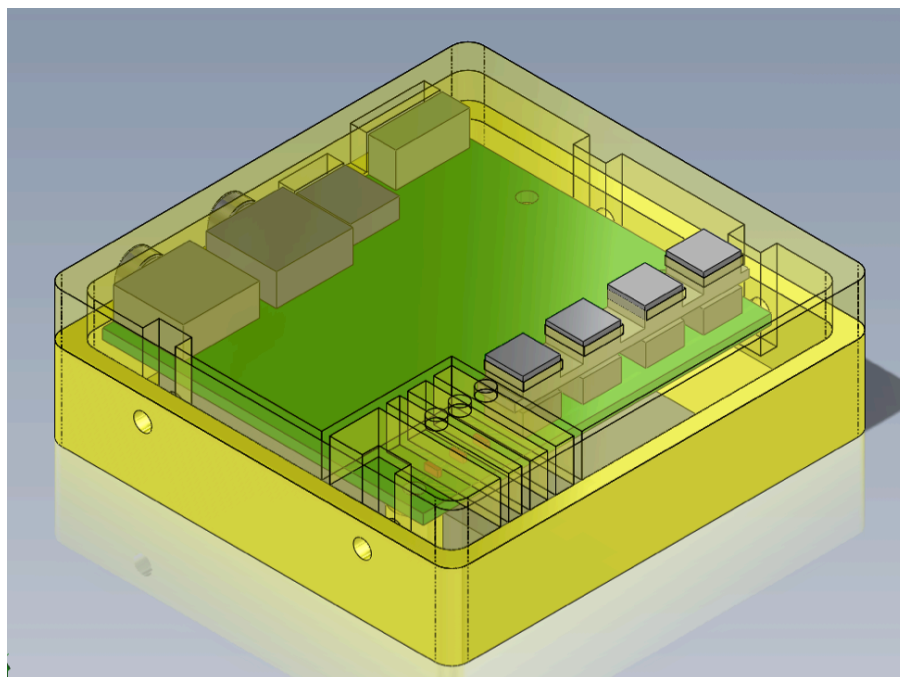

**Figure 4: Solid works Final Product view**

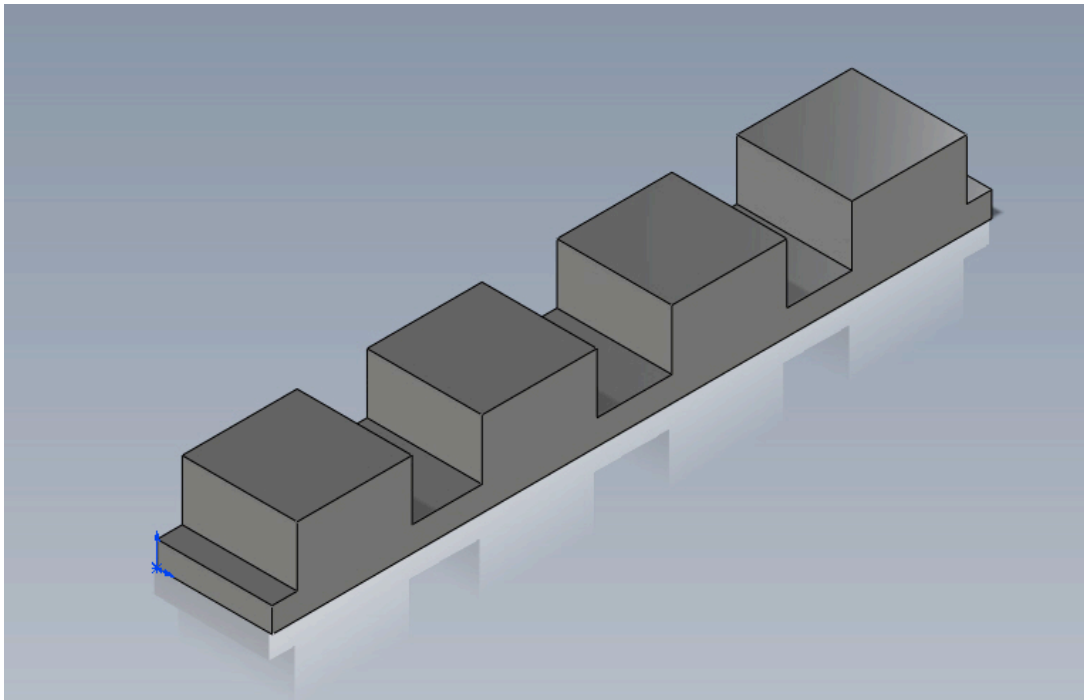

**Figure 5: Solid works of Buttons for BlueBeats**

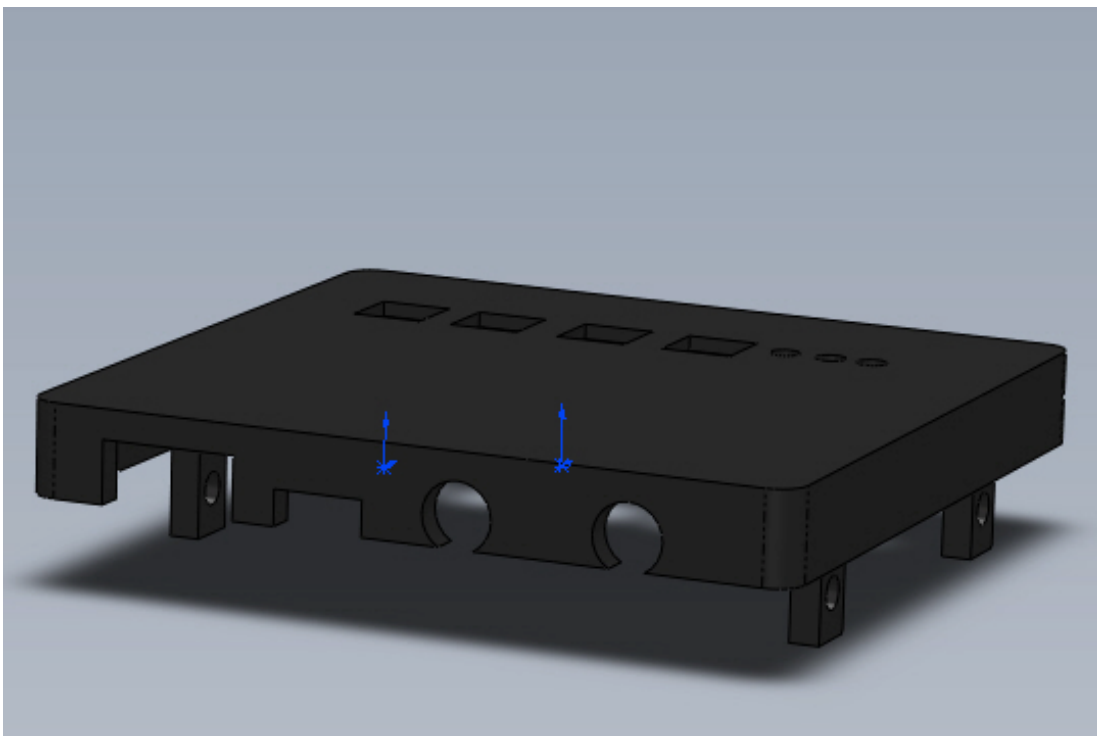

**Figure 6: Solid works of Top case for BlueBeats**



**Figure 7: Inside view of top case**

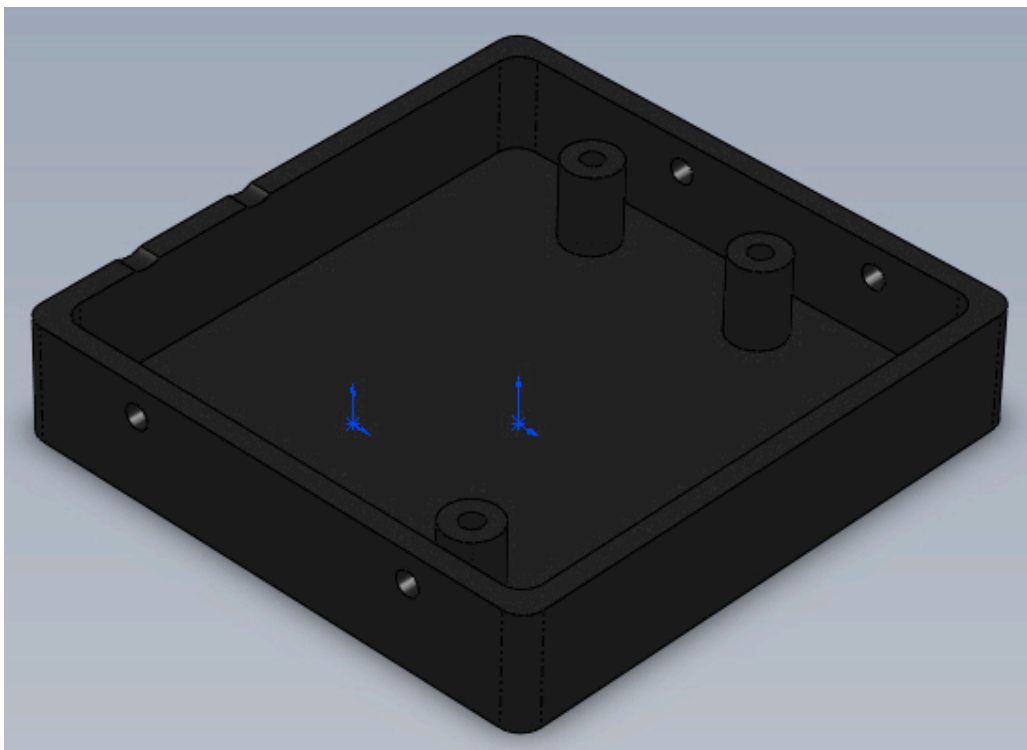

**Figure 8: Solid Works of bottom case**

## **10. Future Work**

Our group believes that BlueBeats has a lot of potential that can be achieved through future iterations and work. Below are some of the extra tasks that can help improve the future of BlueBeats. First, in order to interface with iPhone devices we need to enroll in the MFi program with Apple. This will allow us to use Apples iAP protocol in order to send and receive data between iPhone and BlueBeats device. Apple does not allow Serial Port Protocols. Second, once Android updates the API version for all of the phones they support, the hidden Bluetooth APIs will become available to android developers. We will then be able to reconstruct the android app to use the Bluetooth Profile APIs provided by the Android SDK. Third, update the functionality of the app to remember more user settings. We would change the app to save the user's location when they connected to a specific device. This would allow us to improve our app's usability by connecting the user automatically to certain devices based on their GPS location. Fourth would be to change the BlueBeats system to use NFC so information can be transmitted through touch. Fifth, start a company so our group looks legitimate to potential investors/donors for our product. Finally, create a profile on kickstarter.com so we can raise some money for BlueBeats and show our product to the public.

## 11. Lessons Learned

After completing our BlueBeats project, our group definitely learned a lot since starting in winter quarter. This project helped our group by allowing us to get some hands-on learning experience of programming an Android/Computer application, utilizing Bluetooth functionality from within the application, interfacing with the Bluetooth chip, and going through the process of creating a patent. On the software side, our group learned how to program an Android application and use the Bluetooth APIs provided by Android in order to make a connection from the user's phone to another Bluetooth enabled device. We also learned how to use the Bluecove Bluetooth APIs in order to create a computer application that can connect to a Bluetooth enabled device. This part of the project was interesting because it helped our group understand the process of interfacing an android/computer application with an external hardware device.

On the business side, our group learned a lot about the Business and Legal aspects of creating a product. More specifically, our group learned these aspects by experiencing the patent process, researching how to create a company, and understanding what makes a product manufacturable, sustainable, and profitable. In completing the BlueBeats project, our group went through the process of creating a provisional patent application and got a better understanding of the IP laws for Cal Poly San Luis Obispo. Additionally, applying to the Innovation Quest competition helped our group ask important questions about BlueBeats regarding its profitability, sustainability, and marketability.

On the hardware side, our group learned a lot about using the Bluetooth chip and designing a layout for the board incorporated into BlueBeats. Our group got a lot of hands-on experience with using the Eagle software to create a layout for the BlueBeats board, understanding the documentation for the WT-32 chip, and using UART on arduino to control the WT-32 chip. This valuable experience was gained through embracing Cal Poly's "Learn By Doing" motto since our group had not dealt with the WT-32 chip before.



## 12. Cost Analysis

Development Cost:

Item	Unit Price	Quantity	Total Price
Arduino	\$30	2	\$60
WT32	\$60	2	\$120
Audio 3.5mm Jack	\$2.9	2	\$5.8
Battery	\$14.95	1	\$14.95
Bluetooth Headphones	\$29.99	1	\$29.99
Atmega8u2	\$21.7	1	\$21.7
		<b>Total:</b>	\$252.44

**Table 2: Breakdown of Development Cost**

Cost for a complete BlueBeats:

Item	Unit Price	Quantity	Total Price
Microcontroller (ATMEGA32U2-AU)	\$4.4	1	\$4.4
Bluetooth Chip (WT32)	\$33.33	1	\$33.33
3.5mm Audio Jack	\$0.8	2	\$1.6
Crystal (16MHz)	\$0.9	1	\$0.9
USB Jack (Mini Female)	\$0.54	1	\$0.54
On/Off Slide Switch	\$0.37	1	\$0.37
Mini Tactile Button	\$0.21	4	\$0.84
Capacitor (1uF)	\$0.3	1	\$0.3
Capacitor (18pF)	\$0.05	2	\$0.1
Capacitor (0.1uF)	\$0.04	4	\$0.16
Fuse (1.1Amps)	\$0.4	1	\$0.4
Green LED	\$0.1	1	\$0.1
Red LED	\$0.1	1	\$0.1
Blue LED	\$0.38	1	\$0.38
Resistor (1K)	\$0.01	10	\$0.1
Resistor (4.7K)	\$0.01	10	\$0.1
Resistor (22 ohm)	\$0.06	10	\$0.6
Diode (0.7v drop)	\$0.09	1	\$0.09
Battery	\$14.95	1	\$14.95
Case (3D Prototype)	\$ 36.70	1	\$36.70
		<b>Total:</b>	\$96.06

**Table 3: Cost Breakdown of a BlueBeats Device**

### 13. Work Cited

- [1] Endgadget, “BlackBerry Music Gateway hands-on (video)”,  
<http://www.engadget.com/2012/04/30/blackberry-music-gateway-hands-on-video>
- [2] BlackBerry, “Using the BlackBerry Music Gateway“,  
[http://docs.blackberry.com/en/smartphone\\_users/deliverables/9186/Using\\_the\\_BB\\_Remote\\_Stereo\\_Gateway\\_324597\\_11.jsp](http://docs.blackberry.com/en/smartphone_users/deliverables/9186/Using_the_BB_Remote_Stereo_Gateway_324597_11.jsp)
- [3] BlackBerry, “About the BlackBerry Music Gateway“,  
[http://docs.blackberry.com/en/smartphone\\_users/deliverables/9186/About\\_the\\_BB\\_Remote\\_Stereo\\_Gateway\\_324585\\_11.jsp](http://docs.blackberry.com/en/smartphone_users/deliverables/9186/About_the_BB_Remote_Stereo_Gateway_324585_11.jsp)
- [4] PCWorld, “BlackBerry Music Gateway Uses NFC to Stream Audio”,  
[http://www.pcworld.com/article/254772/blackberry\\_music\\_gateway\\_uses\\_nfc\\_to\\_stream\\_audio.html](http://www.pcworld.com/article/254772/blackberry_music_gateway_uses_nfc_to_stream_audio.html)
- [5] Logitech, “Logitech Wireless Speaker Adapter for Bluetooth audio devices”,  
<http://www.logitech.com/en-us/speakers-audio/home-pc-speakers/devices/wireless-speaker-adapter>
- [6] Belkin, “Bluetooth Music Receiver”,  
[http://www.belkin.com/IWCatProductPage.process?Product\\_Id=508754](http://www.belkin.com/IWCatProductPage.process?Product_Id=508754)
- [7] Amazon, “ Miccus BluBridge Mini-Jack RX: Bluetooth Music Receiver use with Bluetooth-Enabled Mobile Phones, Tablets, PCs and Apple (BBMR-02)“,  
[http://www.amazon.com/Miccus-BluBridge-Mini-Jack-Bluetooth-Bluetooth-Enabled/dp/B0038MA11U/ref=pd\\_bxgy\\_e\\_img\\_b](http://www.amazon.com/Miccus-BluBridge-Mini-Jack-Bluetooth-Bluetooth-Enabled/dp/B0038MA11U/ref=pd_bxgy_e_img_b)
- [8] Amazon, “Miccus BluBridge Mini-Jack: Bluetooth Music Transmitter adds Bluetooth ability to any Non-Bluetooth Audio Source (BBMJ-02)”,  
[http://www.amazon.com/Miccus-BluBridge-Mini-Jack-Transmitter-Non-Bluetooth/dp/B002HHLOWC/ref=pd\\_bxgy\\_e\\_img\\_b](http://www.amazon.com/Miccus-BluBridge-Mini-Jack-Transmitter-Non-Bluetooth/dp/B002HHLOWC/ref=pd_bxgy_e_img_b)
- [9] Sony, “Bluetooth Transmitter and Receiver”,  
<http://store.sony.com/webapp/wcs/stores/servlet/ProductDisplay?catalogId=10551&storeId=10151&langId=-1&partNumber=HWSBTA2W#features>
- [10] Cal Poly Entrepreneurs Website,  
<http://www.cpentrepreneurs.com/s-w-o-t/>

## **14. Appendices**

### **14.1 Appendix A: Patent Application**

#### **Bi-Directional Bluetooth Communication**

##### **BACKGROUND OF THE INVENTION**

[0001] There are currently two common audio problems that exist today. First, there is no easy way for common devices to play audio that accommodates both the needs of user with impaired hearing and normal hearing in the same room. As an example, if there are users with normal hearing in a room, then there is no simple and inexpensive way for a user with impaired hearing to listen to the TV in the same room. By connecting BlueBeats to the TV, it allows the person with impaired hearing to still be present in the room because BlueBeats can transmit the audio from the TV to Bluetooth headphones that a hearing impaired user can wear. As a result, the user with impaired hearing can be listening to the same TV at a volume that suits them without having to disturb any other users in the room. Second, there is not an easy and inexpensive way for user to transmit audio to a speaker system in their home. As an example, if a user is at an event and the user wanted to play music from their smart phone to some speaker system, the user would have to keep their mobile phone plugged in directly to the speaker system the whole time. This poses a risk to the user because unless the user stands next to the speaker system the whole time, it is possible for the mobile device to get stolen. Additionally, a user has to walk to a speaker system every time they want to change the volume, song, or playlist. However, connecting BlueBeats to a speaker system will convert the system into a wireless audio system that will allow a user to keep their phone on their person at all times while still playing music from the speaker system.

##### **BRIEF DESCRIPTION OF THE DRAWINGS**

[0002] Figure A.1 shows a high level description of how BlueBeats works.

[0003] Figure A.2 shows a general description of the Bluetooth Protocol Stack technology

[0004] Figure A.3 shows a concept map of BlueBeats. BlueBeats consists of both a hardware system and a software system.

[0005] Figure A.4 describes the connection between an Arduino Board to the BlueGiga WT32 Bluetooth chip and two 3.5mm audio jacks.

[0006] Figure A.5 shows a schematic design for the hardware system that will be used in BlueBeats.

[0007] Figure A.6 shows the Software flowchart for BlueBeats

[0008] Figure A.7 shows how a computer application of the Software System would interact with the user and BlueBeats

[0009] Figure A.8 shows how an Android application of the Software System would interact with the user and BlueBeats

### **DETAILED DESCRIPTION OF EMBODIMENTS**

[0010] The description of this concept is illustrated through the figures listed, but the full functionality of the concept is not limited only by the figures. These figures are used to aid in describing parts or the whole of the concept.

[0011] The technology behind BlueBeats already exists and there are other companies that currently have Bluetooth dongles that adapt to speaker systems. However, the concept behind BlueBeats is that there is no current product that transmits bi-directional audio signals. BlueBeats solves this problem with the technology that is readily available.

[0012] BlueBeats allows users to make any device Bluetooth-enabled. This facilitates the use of an already owned speaker system that a user may have with a Bluetooth-enabled mobile phone or computer. Also, any music player or television can also utilize BlueBeats to make it wireless and it would facilitate in connecting or hearing music/audio through Bluetooth-enabled headphones.

[0013] Figure A.1 depicts a high level description of how BlueBeats works. The top half of Figure A.1 describes a Bluetooth-enabled phone or laptop using a Bluetooth Stack to connect to BlueBeats. When this connection is made, music will be transmitted from the said phone or laptop to BlueBeats and the

music will play through the speaker system that is connected to BlueBeats through a 3.5mm audio jack. The bottom half of Figure A.1 describes how a television or an audio source, both with a 3.5 mm connection, can be connected to BlueBeats so that music or an audio signal be transmitted to Bluetooth-enabled headphones or to another BlueBeats device that is connected to regular pair of headphones.

**[0014]** Figure A.2 depicts a common description of the Bluetooth Protocol Stack technology. The A2DP profile will be used in this concept to transmit audio from a Bluetooth device to BlueBeats. However, any other profile can be used to transmit any other type of data between BlueBeats and a Bluetooth device. The connection between devices will be made through the RFCOMM protocol, but any other connection may also be made.

**[0015]** BlueBeats consists of both a hardware system and a software system, as described in Figure A.3. The hardware system of this technology uses an ATMEGA microcontroller to communicate with a BlueGiga WT-32 Bluetooth chipset to receive and transmit audio signals. The purpose of having two 3.5mm audio jacks is for using one of the jacks as input to the system and another jack as output to the speaker system.

**[0016]** The ATMEGA microprocessor and WT-32 chipset will both be used to communicate with the software system through a computer application and an Android application. In describing the hardware system, please refer to Figure A.4 for a visual. Figure A.5 shows a schematic of the hardware system. The physical hardware system will contain the following: four buttons (play/pause, next track, volume down, volume up), three LEDs that indicate the level of the BlueBeats battery, status of the connection, and power indicator, two audio jacks (input and output), a USB adapter, and a power button. A rechargeable Lithium-Ion battery will also be included in the device. This hardware device will be able to both receive audio and send it to a speaker system, and transmit audio to a Bluetooth-enabled headphone system.

**[0017]** The basic description of the software procedure is described in Figure A.6, the software flowchart. This flowchart is further described in the implementation of software for smart phone devices and personal computers. Figure A.7 describes the process of how a computer application may be used to

interact with BlueBeats and the end-user. Figure A.7.1 shows the basic view of the main screen of the BlueBeats application. This is what the user will see when they first start up the application. Since there are no devices on the list, the only buttons that are enabled are the SCAN button, which will scan for devices, and the EXIT button. Figure A.7.2 shows the effects of pressing the SCAN button. Another window will display and let the user that the application is currently scanning for Bluetooth-enabled devices. Once the scan is complete another window shows the devices that have been found, as seen in Figure A.7.3. From here, a user will be able to select which devices should be added to the main list, with the option of adding more than one device. After selecting the device/s to add, the user can exit out of that window. Figure A.7.4 shows the device that was chosen in the main screen. From here, a user may be able to pair with such device and stream music to it.

**[0018]** Figure A.8 depicts a similar description to that of the previous paragraph, except that this application is for an Android device. Figure A.8.1 shows the applications screen of an Android device, with BlueBeats being one of the many applications that the Android device has installed. When the program first starts off, as shown in Figure A.8.2, it only has limited functionality because a search for Bluetooth-enabled devices has not been made. In order to search for devices, a user must press the logical ADD button. The result of pressing this logical button is shown in Figure A.8.3. From here, a user may choose the device that should be added to the main screen list. Figure A.8.4 shows a device that was chosen to be added to the main list. Now that a device is in the main screen, more options are present for such device. These options include removing the device from the list, or pairing to it. To pair a device, select the logical PAIR button. From here the Android application will try and pair to the device, and once paired the user will be asked to use the device as an A2DP connection or as a headphone connection. These previous steps are illustrated in Figures A.8.5 and A.8.6. Once the device is paired with BlueBeats, the user has the option of renaming the device and giving it a friendlier name. Refer to Figure A.8.7 for a visual representation of this feature.

[0019] The previously described applications are developed using Java and Eclipse. The Android application uses the Android Bluetooth API to connect to BlueBeats, while the Windows application uses the BlueCove Bluetooth API to connect to BlueBeats. The initial connection between both applications and BlueBeats is through an RFCOMM connection. This RFCOMM connection acts as a Serial Port Protocol connection. This technique was used because the Bluetooth APIs that we were using did not support an A2DP connection. Since this type of connection was needed to transmit music from a certain device to BlueBeats, we had to come up with a solution that would work. Using the RFCOMM profile, a secure connection was made to BlueBeats. Once this connection was made, commands were sent from the applications to BlueBeats so that it would enable the A2DP profile. Once this profile was activated, it was possible to stream music from a device running BlueBeats software to the BlueBeats hardware.

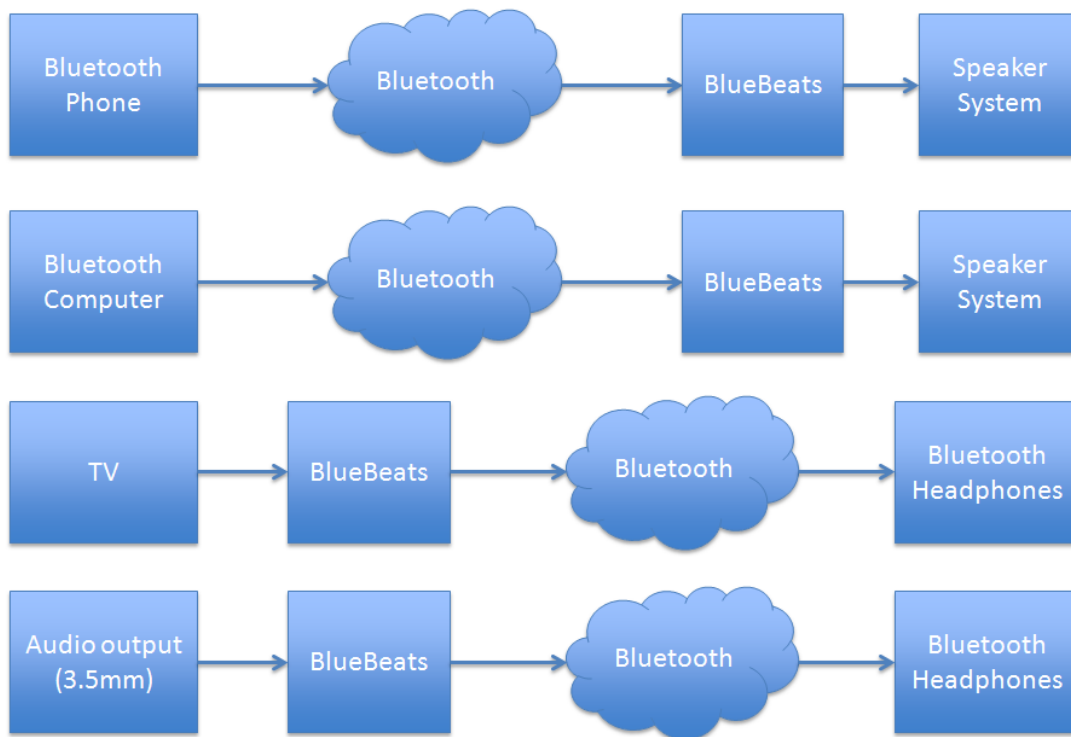

**Figure A.1: BlueBeats High Level Description**



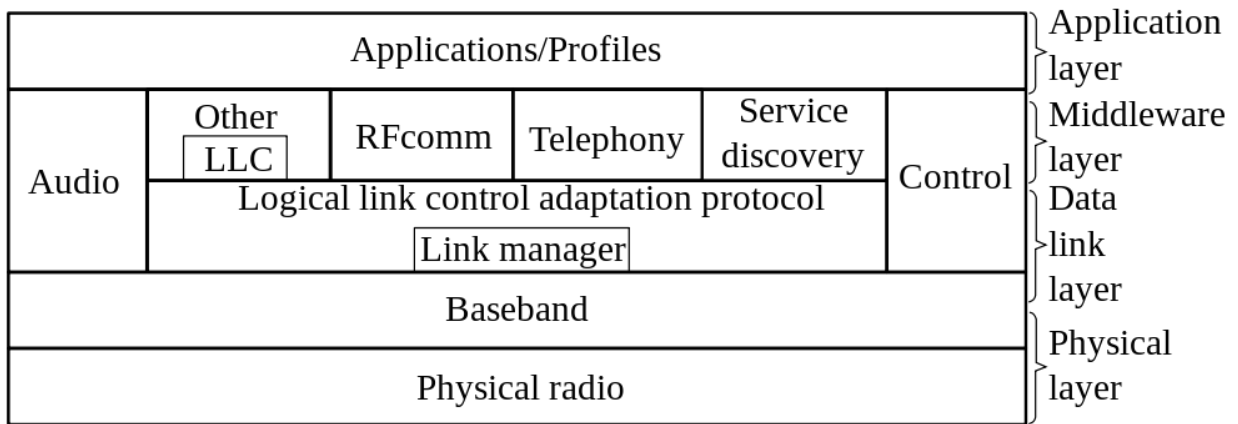

**Figure A.2: Bluetooth Protocol Stack**



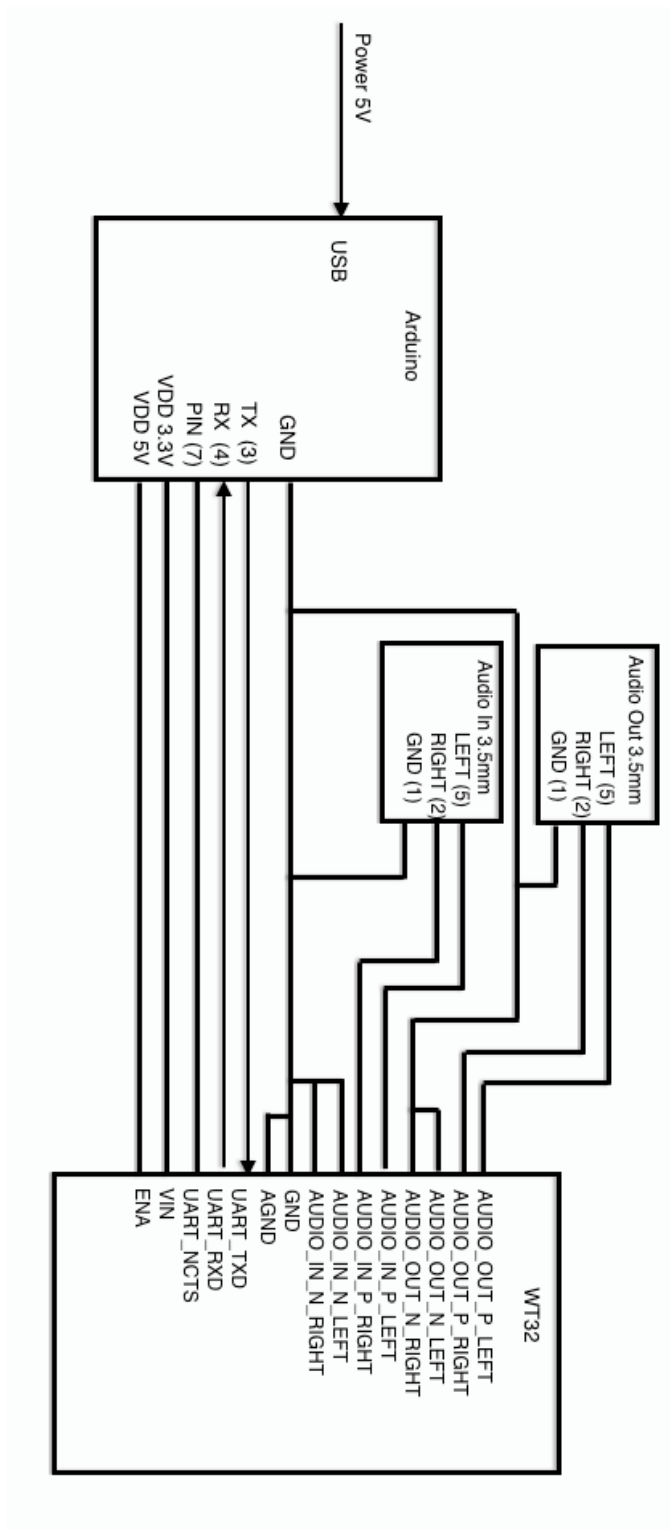
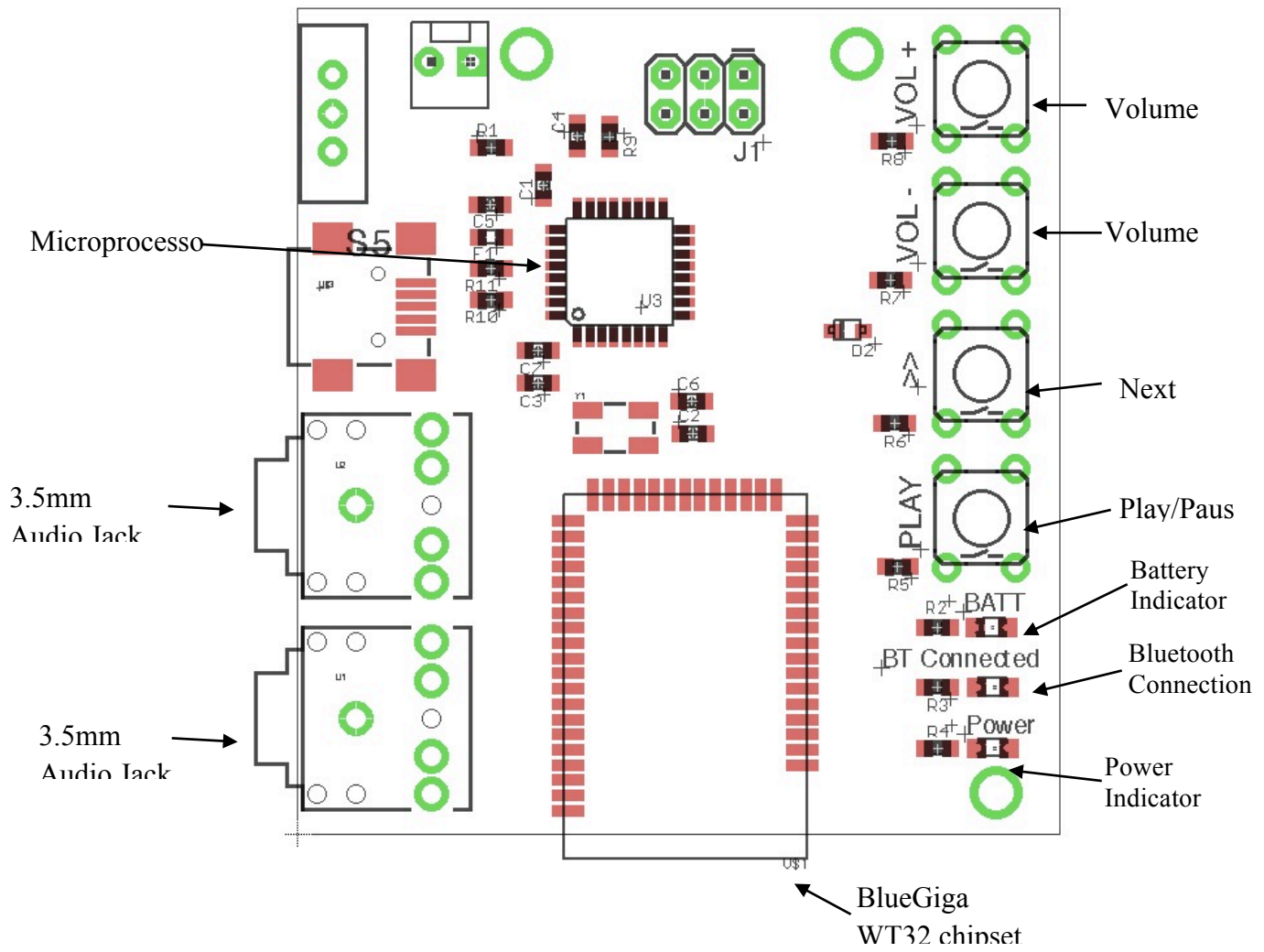
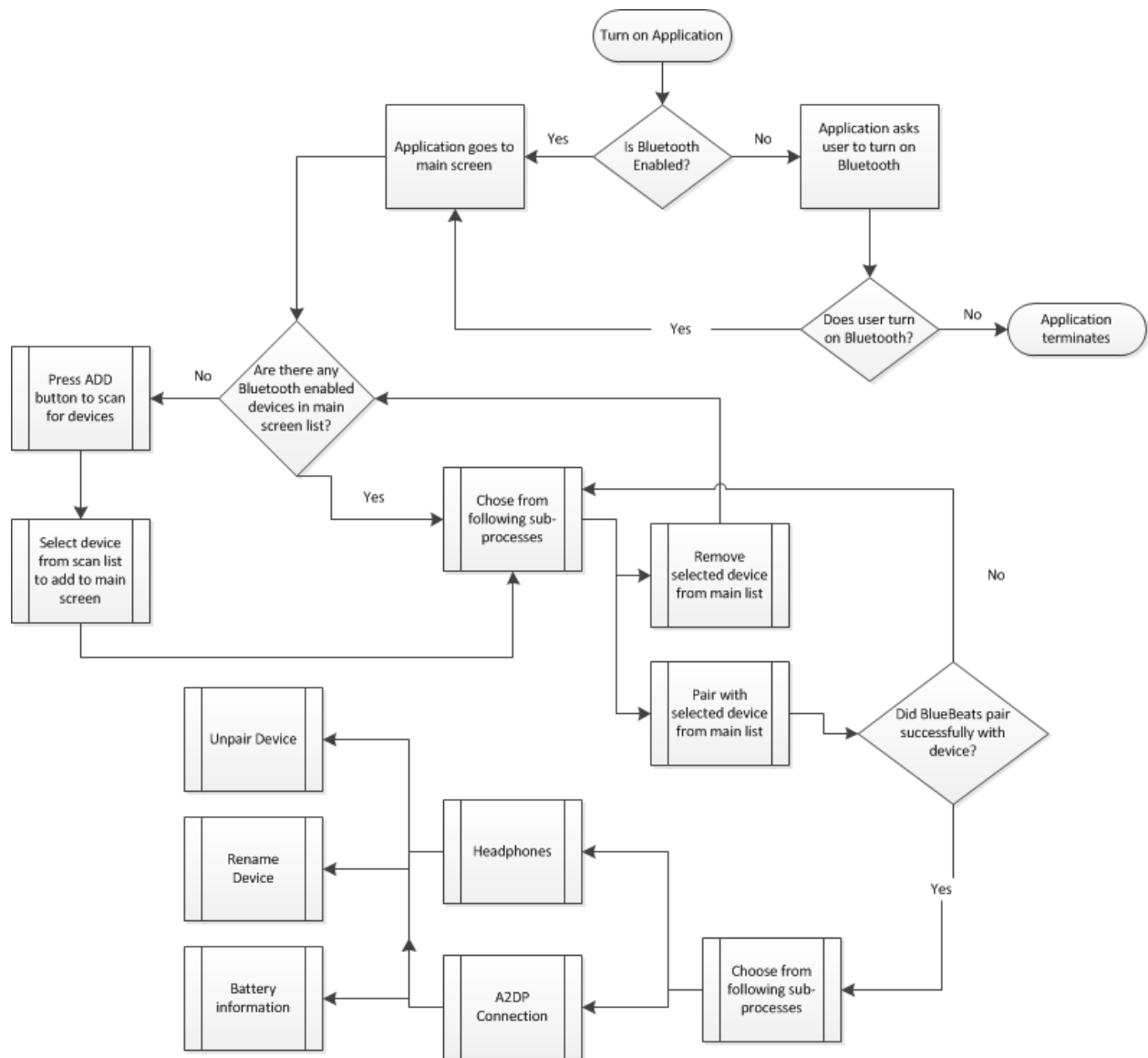

Figure A.4: BlueBeats Hardware System

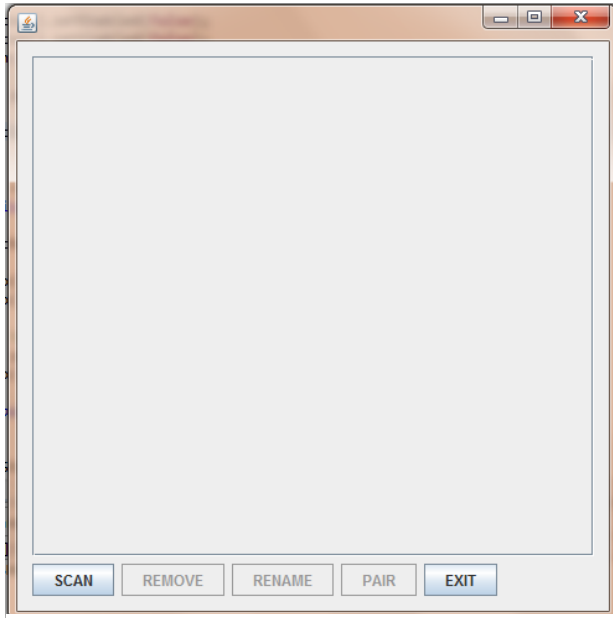

**Figure A.5: Hardware Printed Circuit Board**

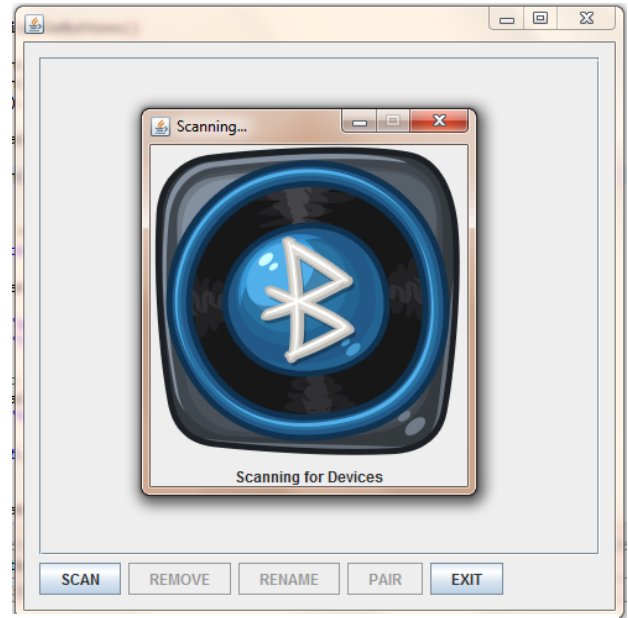

**Figure A.6: Software Design Flowchart**

Figure A.7: BlueBeats Computer Application



**A.7.1 Start-Up Application Screen**



**A.7.2 Application Scanning for Devices**

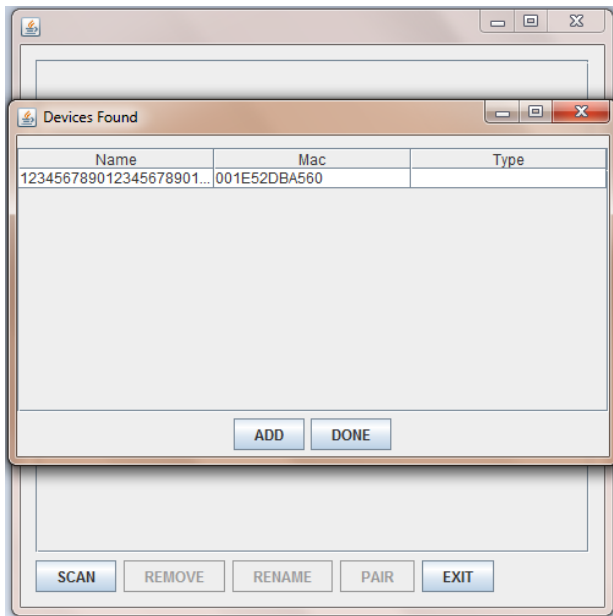

**A.7.3 Application Found Devices**

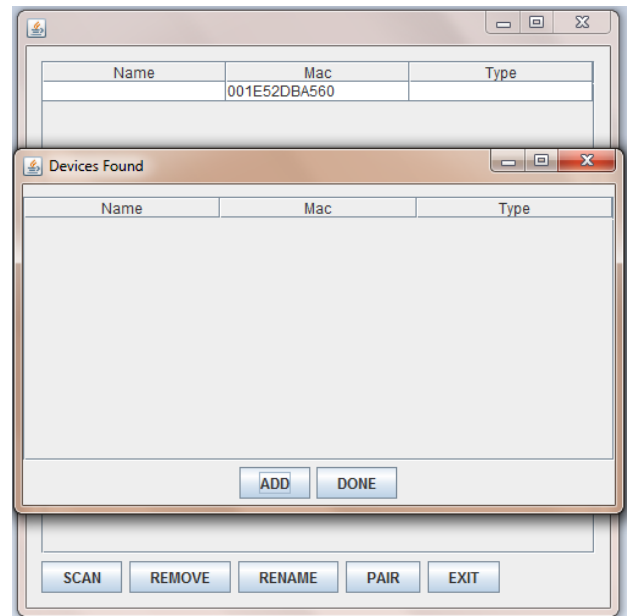

**A.7.4 Device Found Added to Main Screen**

Figure A.8: BlueBeats Android Application

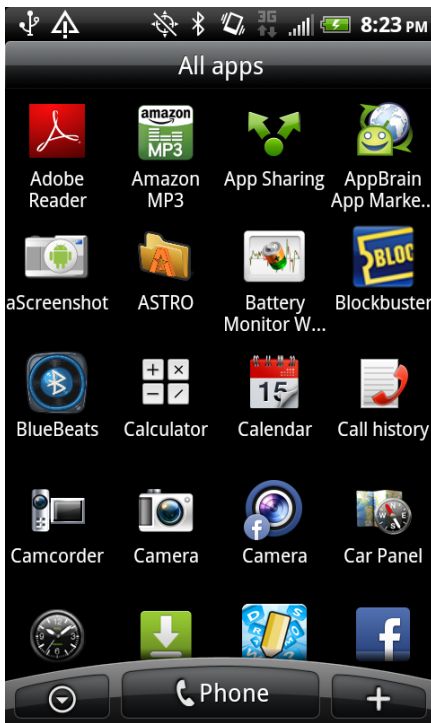

**A.8.1 Android Application**

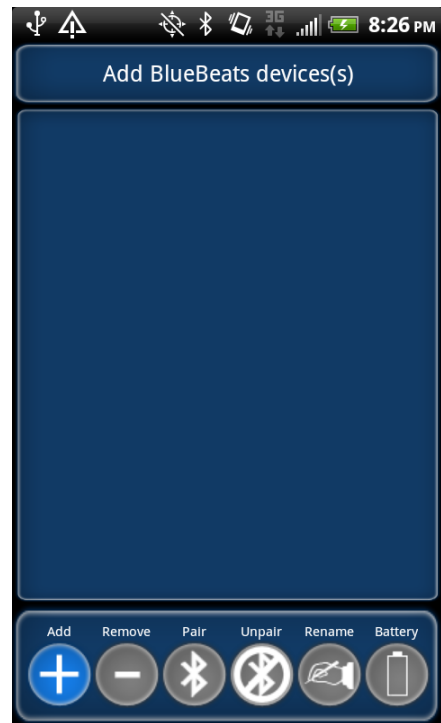

**A.8.2 BlueBeats Main Screen**

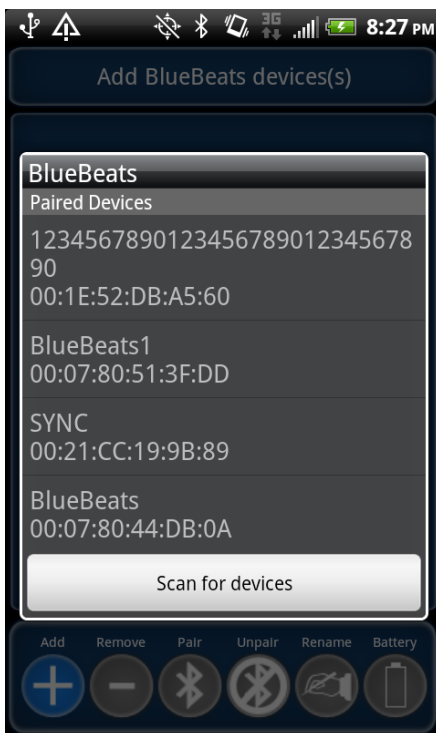

**A.8.3 BlueBeats Scanning for Devices**

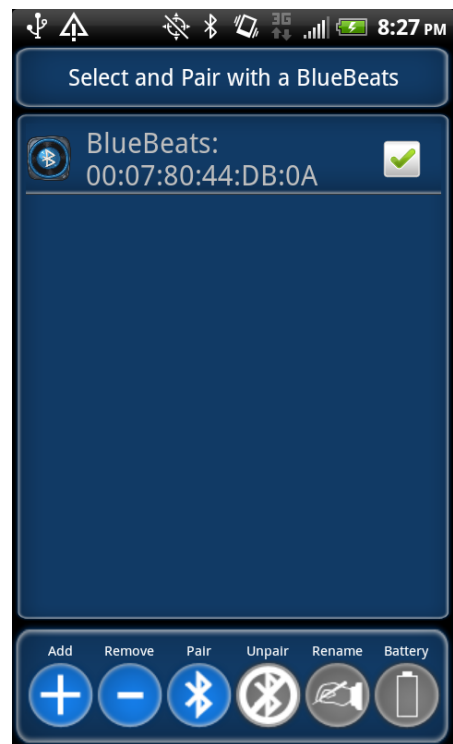

**A.8.4 Selected Bluetooth Device in Main Screen**

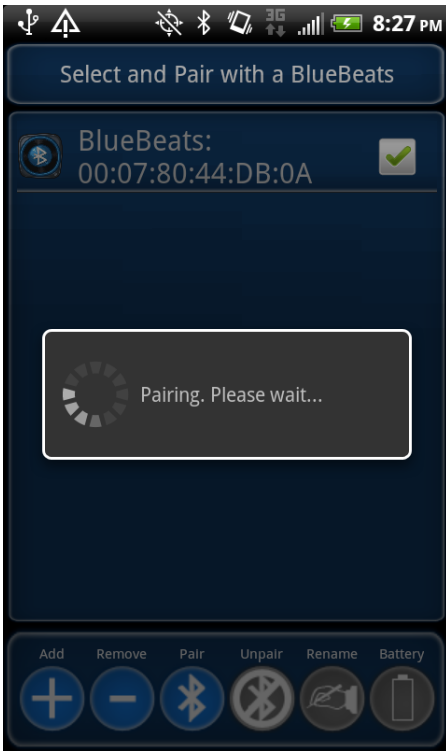

**A.8.5 Pairing with Bluetooth Device**

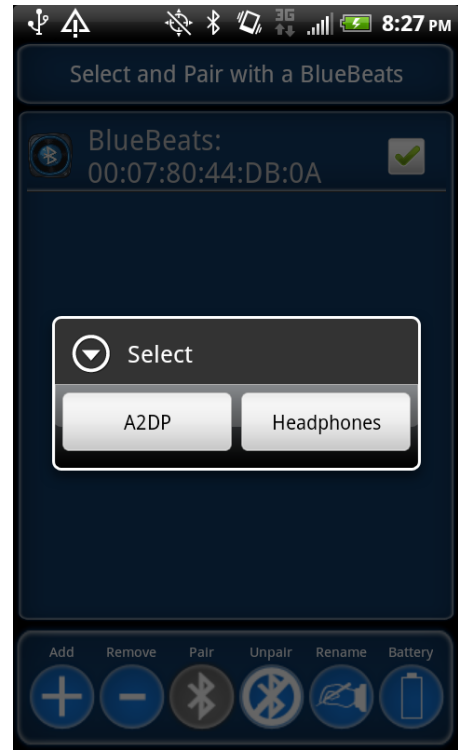

**A.8.6 Select Type of Service**

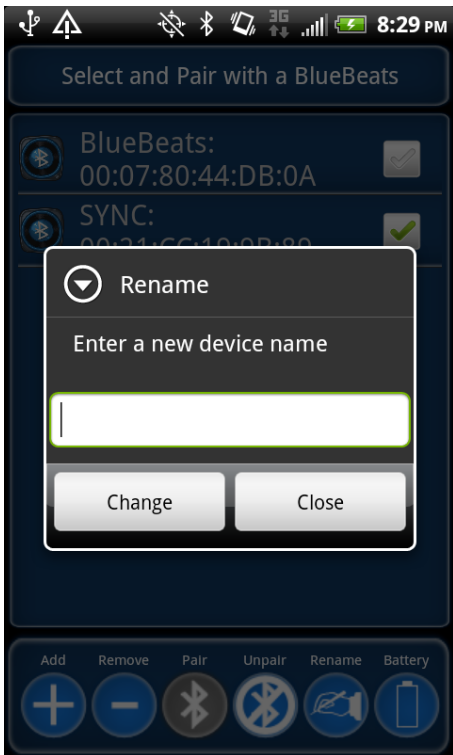

**A.8.7 Rename Selected Bluetooth Device**

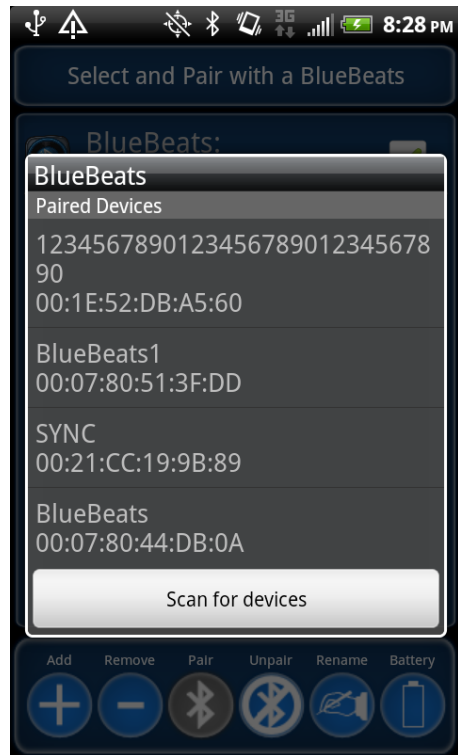

**A.8.8 BlueBeats Searching for Headphones**



## 14.2 Appendix B: SPP commands

Android Device	BlueBeats
Start Device Inquiry: “Device inquiry”	Send Device found around BlueBeats: Sending Name and BTAddress with current count: “BlueBeats scan <#> <name> <BTAddress>” No Device Found: “BlueBeats scan <0> <name> <BTAddress>” Fail to scan: “BlueBeats scan <-1> <name> <BTAddress>”
Connect with: “Device connect <#> <name> <BTAddress>” Close App or Close pair: “Device connect <-1>”	Connected: “BlueBeats connection 1” Connection Failed: “Bleubeats connection -1”
Send Pin: “Device ? <PIN NUMBER>”	Asking for Pin: “BlueBeats ?”
Device Rename: “Device rename <NEW NAME>” Note: max of 16 chars	Renamed: “BlueBeats renamed 1” Renamed Failed: “BlueBeats renamed -1”
Device Remove: “Device remove <name> <BTAddress>”	Removed: “BlueBeats removed 1” Renamed Failed: “BlueBeats removed -1”
Get BlueBeats Battery level: “Device battery level”	Send BlueBeats Battery level: “BlueBeats battery <mVoltage>”
is BlueBeats charging: “Device battery charging”	Send Battery charging: “BlueBeats battery 1” Battery not charging: “BlueBeats battery -1”

### 14.3 Appendix C: BlueBeats Non-Disclosure Agreement

## MUTUAL NON-DISCLOSURE AGREEMENT

#### COMPANY INFORMATION:

Company Name: (the "Company")

Place of Incorporation:

Principal Place of Business Address:

City/State/Provinces:

Zip: Country:

Contact Name:

Contact Phone:

Contact Fax:

E-mail Address:

#### BlueBeats INFORMATION:

BlueBeats

California Polytechnic University

San Luis Oispo, CA 93405

Tel: XXX XXX XXXX

Fax: xxx xxx xxxx

Contact Name:

Contact Phone:

Contact Fax:

E-mail Address:

This Agreement consists of three pages including this cover page and the attached terms and conditions.

EFFECTIVE DATE:

BlueBeats and the Company identified below (hereinafter referred to as the "Parties") have entered into this Agreement as of the Effective Date written above.

PURPOSE: To facilitate discussions about, and the evaluation of, a potential and/or an on-going business relationship between the Parties.

Signatures of the Parties for the Mutual Non-Disclosure Agreement:

**COMPANY:**

**BLUEBEATS, INC.**

\_\_\_\_\_  
Authorized Signature

\_\_\_\_\_  
Authorized Signature

\_\_\_\_\_  
Name

\_\_\_\_\_  
Name

\_\_\_\_\_  
Title

\_\_\_\_\_  
Title

## TERMS & CONDITIONS

THE PARTIES HEREBY AGREE AS FOLLOWS:

### SECTION 1. PURPOSE OF DISCLOSURE

The Parties and their Affiliates (as defined in Section 3(A) below) would like to exchange Confidential Information (as defined in Section 2 below) solely in order to facilitate discussions about, and the exchange of information with respect to, the Purpose (as identified on the cover page of this Agreement). Now, therefore, to ensure the protection of such Confidential Information and in consideration of the agreement to exchange information, the parties agree as follows:

### SECTION 2. CONFIDENTIAL INFORMATION

Each party may find it beneficial to disclose to the other party certain information on or after the Effective Date, including, without limitation any idea, trade secrets, finding, research, data, specification, process, technique, algorithm, architecture, know-how, invention, design, manufacturing, plan, drawing, sketch, product schematic, document, manual, report, study, photograph, sample, program, source code, object code, prototype, customer list, price list, pricing methods, product description, business plan, business concepts, marketing plan, financial information, or work in process. Such information, which is provided in written, encoded, graphic, or other tangible form shall be deemed to be confidential and proprietary if it is clearly marked confidential. If the information is provided orally, it shall be deemed to be confidential and proprietary if so identified by the disclosing party at the time of such disclosure. Each party may confirm, within five (5) days of making oral confidential statements, that such information was confidential and proprietary. The information disclosed as set forth above shall be deemed "Confidential Information."

### SECTION 3. NON-DISCLOSURE OBLIGATIONS

Each party receiving Confidential Information shall treat such information as strictly confidential, and shall use the same care to prevent the disclosure of such information as such party uses with respect to its own confidential and proprietary information (which shall be no less than the care a reasonable person would use under similar circumstances) and to use the Confidential Information solely for the Purpose. In any event, each party receiving Confidential Information shall:

(A) Disclose such Confidential Information to only those officers, directors, employees, consultants and/or Affiliates ("Representatives") (1) whose duties justify their need to know such information and (2) who have been clearly informed of their obligation to maintain the confidential, proprietary and/or trade secret status of such Confidential Information. "Affiliates" shall mean any company, existing now or in the future, owning or owned by, either directly or indirectly, or controlling, controlled by or under common control with either party, and their directors, officers and employees;

(B) Disclose the fact that it has received such Confidential Information only to Representatives of such party (1) whose duties justify their need to know such fact and (2) who have been clearly informed of their obligation to maintain the confidential status of such fact.; and

(C) Use such Confidential Information only for the purpose of reviewing, analyzing and discussing with the disclosing party.

Without the disclosing party's prior consent, the receiving party will not, and will direct its Representatives not to, disclose to any person either the fact that discussion or negotiations are taking place concerning cooperative activities of the status thereof. The term "person" as used in this Agreement shall be broadly interpreted to include without limitation any corporation, company, partnership, other legal entity and individual.

If the receiving party wishes to disclose, reveal, or communicate any portion of the Confidential Information to any other party than the Representatives, it shall have to receive the disclosing party's written consent to such a disclosure and the receiving party undertakes to make sure that such a party shall sign a similar confidential and non-disclosure agreement with the disclosing party.

Each party receiving Confidential Information shall, immediately upon the request of the disclosing party or in the event that no cooperative activity is commenced between the parties, or upon fulfillment of the Purpose, (i) return to the disclosing party all Confidential Information received from the disclosing party, including all copies thereof made by the receiving party or any of its Representatives without retaining any copy thereof or any computer or other electronic record, (ii) destroy all materials incorporating or based on such Confidential Information which were prepared by the receiving party or any of its Representatives, (iii) certify to the disclosing party in writing that it has complied with the provisions of this Section 3 and (iv) ensure that any Representative to which it has disclosed the Confidential Information does the same.

### SECTION 4. EXCEPTIONS TO NON-DISCLOSURE OBLIGATIONS

The obligations set forth in Section 3 above shall not apply to any Confidential Information:

(A) Which the disclosing party expressly agrees in writing is free of any nondisclosure obligations;

(B) Which, at the time of disclosure to the receiving party, was known to the receiving party or any of its Representatives (as evidenced by documentation in the possession of the receiving party or its Representatives) free of any nondisclosure obligations;

(C) Which is independently developed by the receiving party or any of its Representatives (as evidenced by documentation in the possession of the receiving party or its Representatives); or which is lawfully received by the receiving party or any of its Representatives, free of any nondisclosure obligations, from a third party which the receiving party or its Representatives reasonably believe has the right to so furnish such Confidential Information;

(D) Which is or becomes generally available to the public without any breach of this Agreement; or

(E) Which must be disclosed pursuant to applicable federal, state or local law, regulation, court order or other legal process, provided the receiving party has notified the disclosing party prior to such required disclosure and, to the extent reasonably possible, has given the disclosing party an opportunity to contest such required disclosure at the disclosing party's expense.

## SECTION 5. TERM

This Agreement shall become effective as of the Effective Date and shall remain in effect until terminated by either party giving thirty (30) days' prior written notice of termination to the other party. Upon any termination of this Agreement for any reason, each party's obligations hereunder with respect to Confidential Information received prior to such termination shall continue for a period of three (3) years after the date of such termination.

## SECTION 6. GENERAL

A. NO COMMITMENT. Neither party has any obligation to disclose any Confidential Information to the other party. In addition, neither this Agreement, nor the disclosure or receipt of Confidential Information hereunder, shall constitute or imply any promise or intention by either party to enter into any other agreement or transaction or to continue discussions relating thereto.

B. NO LICENSE GRANTED. All Confidential Information shall remain the property of the disclosing party, and nothing contained in this Agreement shall be construed as granting or conferring any rights whether by license or otherwise to any Confidential Information.

C. COMPETITION. Nothing in this Agreement shall prohibit or restrict either party's right to disclose its own Confidential Information to any third party for any purpose whatsoever, nor to develop, use, license, acquire or market products or services similar to or competitive with those of the other party disclosed in the Confidential Information as long as it shall not thereby breach this Agreement. Additionally, each party acknowledges that the other may already possess or has developed products or services similar to or competitive with those of the other party to be disclosed in the Confidential Information. Further, either party shall be free to use for any purpose the 'residuals,' provided that such party shall not use in any manner information that is considered Confidential Information under this Agreement and shall

maintain the confidentiality of the Confidential Information as provided herein. The term 'residuals' means ideas, concepts, know-how or techniques that may be generated, developed or conceived by the receiving party in connection with reviewing the Confidential Information and in no circumstance shall 'residuals' be deemed to include Confidential Information. Neither party shall have any obligation to limit or restrict the assignment of such persons or to pay royalties for any work resulting from the use of residuals.

D. NO REPRESENTATIONS. No party shall be deemed to make any expressed or implied representation, warranty, assurance or guarantee with respect to any Confidential Information disclosed hereunder, including without limitation any representation or warranty of merchantability, fitness for any particular purpose, or non-infringement of intellectual property or other rights of third parties.

E. DISPUTE RESOLUTION; GOVERNING LAW AND FORUM. The parties to this Agreement shall use all reasonable efforts to resolve any disputes, controversies or differences arising out of or in connection with this Agreement amicably, including the use of a mutually agreeable, non-binding mediation procedure. Any dispute which cannot be settled by mutual agreement or mediation shall be finally and exclusively settled by arbitration held in San Francisco, California and conducted by the American Arbitration Association (the "AAA") in accordance with the International Arbitration Rules of the AAA, as modified or amended by the following provisions. Arbitration shall be by three (3) arbitrators, one chosen by the Company, one chosen by BlueBeats and the third chosen by the two arbitrators selected by the Parties or appointed by the AAA. Once appointed pursuant to this procedure, the arbitral tribunal may order provisional or conservatory measures (including injunctive relief) at the request of one party and may embody such order in any final award. Nothing in the foregoing precludes, restricts or is intended to preclude or restrict the right of either party to seek injunctive or other equitable relief in an appropriate court of competent jurisdiction. English shall be the official language of the arbitration proceedings. The arbitrators shall make a decision which is in accordance with the terms of this Agreement, shall apply the law of the State of California, without regard to its conflicts of laws principles, and shall state the basis for any decision in writing. Judgment upon the award rendered may be entered in any court having jurisdiction or application may be made to such court for judicial acceptance of the award and an order of enforcement as the case may be.

F. SEVERABILITY. If any provision of this Agreement is determined to be unenforceable for any reason, the remaining provisions hereof shall be unaffected and remain in full force and effect.

G. MODIFICATIONS. Any modification, amendment, supplement, or other change to this Agreement must be in writing and signed by both parties. As used herein, the term "Agreement" shall include any future amendments or supplements hereto. An executed original of this Agreement

may be delivered by facsimile, which shall be binding as an original.

H. WAIVERS. All waivers must be in writing. The failure of either party to insist upon strict performance of any provision of this Agreement, or to exercise any right provided for herein, shall not be deemed to be a waiver for the future of such provision or right, and no waiver of any provision or right shall affect the right of the waiving party to enforce any other provision or right herein.

I. EQUITABLE REMEDIES. The parties agree that any breach of this Agreement, including without limitation any actual or threatened disclosure of Confidential Information without the express prior written consent of the disclosing party, would cause irreparable injury to the disclosing party for which no adequate remedy at law exists; therefore, the parties agree that in addition to all other remedies available to the parties, equitable remedies, including without limitation unilateral injunctive relief and specific performance, without the requirement of posting a bond (where applicable), are appropriate remedies to redress any breach or threatened breach of this Agreement by the receiving party, any of its Representatives, or any other persons directly or indirectly acting for or on behalf of or with the receiving party.

J. RIGHTS AND REMEDIES. All rights and remedies hereunder shall be cumulative, may be exercised singularly or concurrently, and shall not be deemed exclusive. If any legal action is brought to enforce any obligations hereunder, the prevailing party shall be entitled to receive its attorneys' fees, court costs and other collection expenses, in addition to any other relief it may receive. This Agreement is not intended to provide any rights or remedies to any person or entity other than the parties and their respective successors and assigns.

K. CONSTRUCTION. The headings and subheadings contained herein shall not be considered a part of this Agreement. This Agreement may be executed in several

counterparts, all of which shall constitute one agreement. Each person and party executing this Agreement represents and warrants that it has full power and authority to enter into this Agreement on behalf of the entity, referenced in the signature block on the cover page. This Agreement may be delivered by means of facsimile transmission and facsimile copies shall be deemed originals if executed by both parties and delivered by facsimile. This Agreement shall bind, and inure to the benefit of, each party and its successors and assigns.

L. NOTICES. Any notice or communication permitted or required hereunder shall be in writing and shall be delivered in person or by courier, sent by electronic facsimile (fax), or mailed by certified or registered mail, postage prepaid, return receipt requested, and addressed as set forth on the cover page with a copy to the Legal Department or to such other address as shall be given in accordance with this Section 6(L). If notice is given in person, by courier or by fax, it shall be effective upon receipt; and if notice is given by mail, it shall be effective three (3) business days after deposit in the mail.

M. RELATIONSHIP BETWEEN PARTIES. Nothing contained in this Agreement shall be construed to constitute either party hereto as the partner, employee, agent or other representative of the other party hereto.

N. EXPORT CONTROL LAWS. Each party shall comply with all provisions of the export control laws of the United States and other relevant countries as such laws currently exist and as they may be amended from time to time, with respect to any export of Confidential Information.

O. ENTIRE AGREEMENT. This Agreement is the final, complete and exclusive agreement between the parties relating to the Confidential Information, and supersedes all prior or contemporaneous proposals, understandings, representations, warranties, promises and other communications relating to such subject matter.

END OF TERMS & CONDITIONS

## **14.4 Appendix D: Innovation Quest**

**Host University:** Cal Poly SLO University of Connecticut

**Project Name:** BlueBeats

**First Name:** Mishal

**Last Name:** Shah

**Field/Major:** Computer Engineering

**Email:** mdshah@calpoly.edu

**Team, Club, or Startup Name:** BlueBeats

**Faculty Sponsor/Advisor:** Dr. Smith

**Please limit your answers to 5000 characters (about 1000 words) or fewer.**

### **Describe Your Product or Service:**

Currently, there is no easy and inexpensive way to get a flexible home audio system. Most of the home audio systems do not come with Bluetooth capability, which limits the user from streaming their audio files from phones or computers to the home audio system. These home audio systems can be greatly improved if they allow a user to control the speaker systems that a device is connected to through a Bluetooth device. This gives people control over their speaker systems by allowing them the ability to select the speaker system that they would want to play music on. An additional issue people face is that they may have problems listening to music or TV at a low volume. BlueBeats will solve this problem by transmitting the audio feed from these devices to a Bluetooth headset or Bluetooth speaker system.

### **What do we get to see at the end of the project (form of prototype, etc.)?**

The end prototype will be able to play and transmit audio. It will be a proof of concept.

## **Key concept that must be validated, proved, prototyped**

The key concept that must be proved is the ability to pair a Bluetooth-enabled computer or smartphone with BlueBeats and be able to transmit audio files to an audio system.

## **PRIMARY CRITERIA**

### **What is the essential INNOVATION in your product or service?**

The essential innovation in our product can be seen in our solution to two common audio problems that exist in the world today. First, there is currently not an easy way for common devices to play audio that accommodates both the needs of people with impaired hearing and normal hearing in the same room. As an example, if there are users with normal hearing in a room, then there is no simple and inexpensive way for a user with impaired hearing to listen to the TV in the same room. By connecting BlueBeats to the TV, it allows the person with impaired hearing to still be present in the room because BlueBeats can transmit the audio from the TV to Bluetooth headphones that a hearing impaired user can wear. As a result, the person with impaired hearing can be listening to the same TV at a volume that suits him/her without having to disturb everyone else in the room. Second, there is no easy and inexpensive way for people to transmit audio to a speaker system in their house. As an example, if a person is at an event and they wanted to play music from their smart phone to a speaker system, they would have to keep it connected directly to the speaker system the whole time. This is an inconvenience to the individual because unless they stand next to the speaker system the whole time, it is possible for the phone to be stolen. Additionally, someone has to walk to the speaker system every time they

want to change the volume, song, or playlist. However, connecting BlueBeats to the speaker system will convert it into a wireless audio system that will allow the person to keep their phone on them at all times while still playing music to the speaker system. By having the solutions to problems like these in one device, it shows the innovation that was used to create BlueBeats.

### **What is the COMMERCIAL POTENTIAL?**

The commercial potential for this device is to either sell it as an individual module or sell our device to a third party manufacturer that may sell Bluetooth headphones/dongles.

### **Describe the HOT MARKET your product/service is addressing.**

The hot market that our product is addressing is the versatility of Bluetooth audio technology.

### **SECONDARY CRITERIA**

#### **What is your benefit to mankind/sustainability.**

Being able to utilize Bluetooth technology in everyday equipment to make a wireless audio system.

#### **Describe your team and multidisciplinary members.**

This team is composed of three Computer Engineering students and one Computer Science student. Two of the Computer Engineers work on the electronic circuit design and microcontroller programming while the other two students work on the mobile device software.



We have also reached out to individuals with business background to guide us on the business planning of this project. Volunteer students are going to help create the electronic board enclosure.

**Do you currently have a go-to-market plan? If so, describe briefly.**

There is no current go-to-market plan for this prototype

**What are the names, majors, and e-mail addresses of the other participants?**

Name: Aarón Martinez

Major: Computer Engineering

E-mail: amarti51@calpoly.edu

Name: Jake Muir

Major: Computer Science

E-mail: jimuir24@gmail.com

Name: Richard Wissemann

Major: Computer Engineering

E-mail: rwiseema@calpoly.edu

## 14.5 Appendix E: Level 2 Design

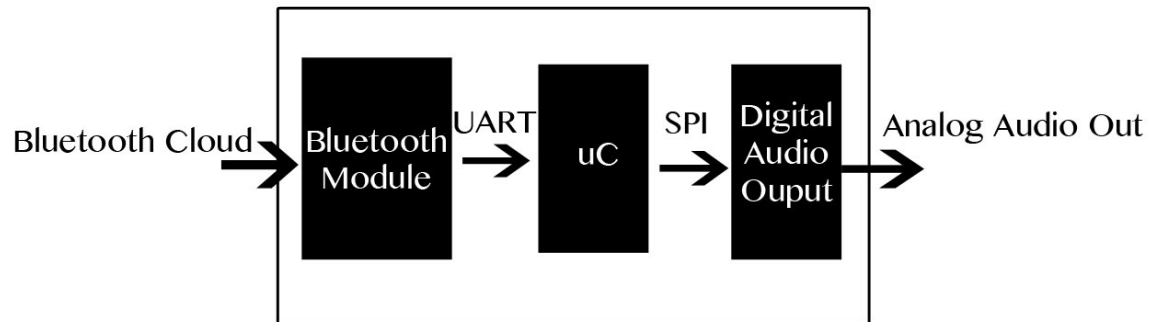

## 14.6 Appendix F: BlueBeats Overview Diagram

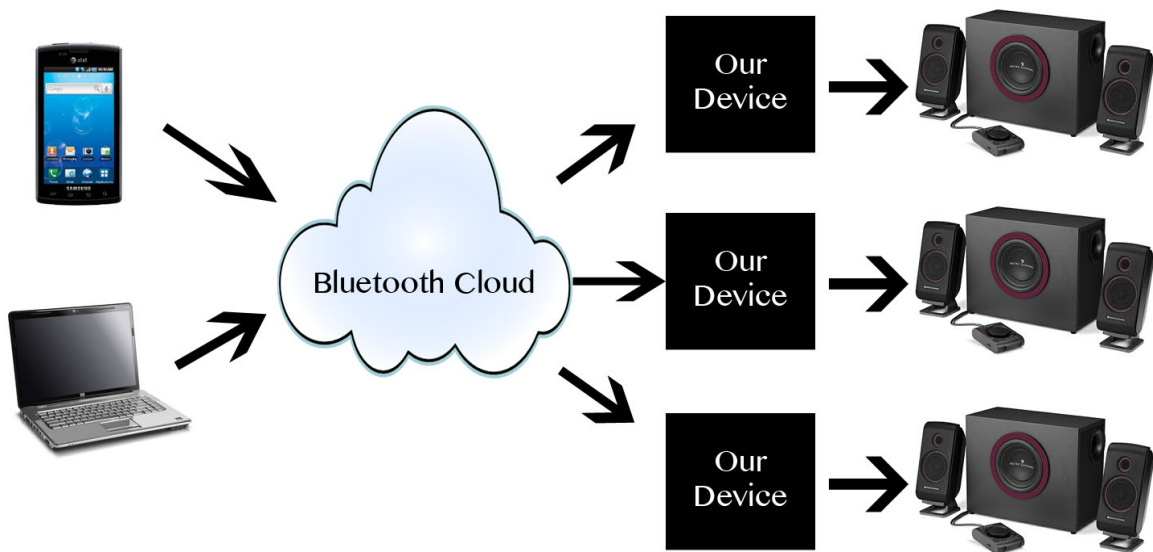

## 14.7 Appendix G: RFCOMM connection

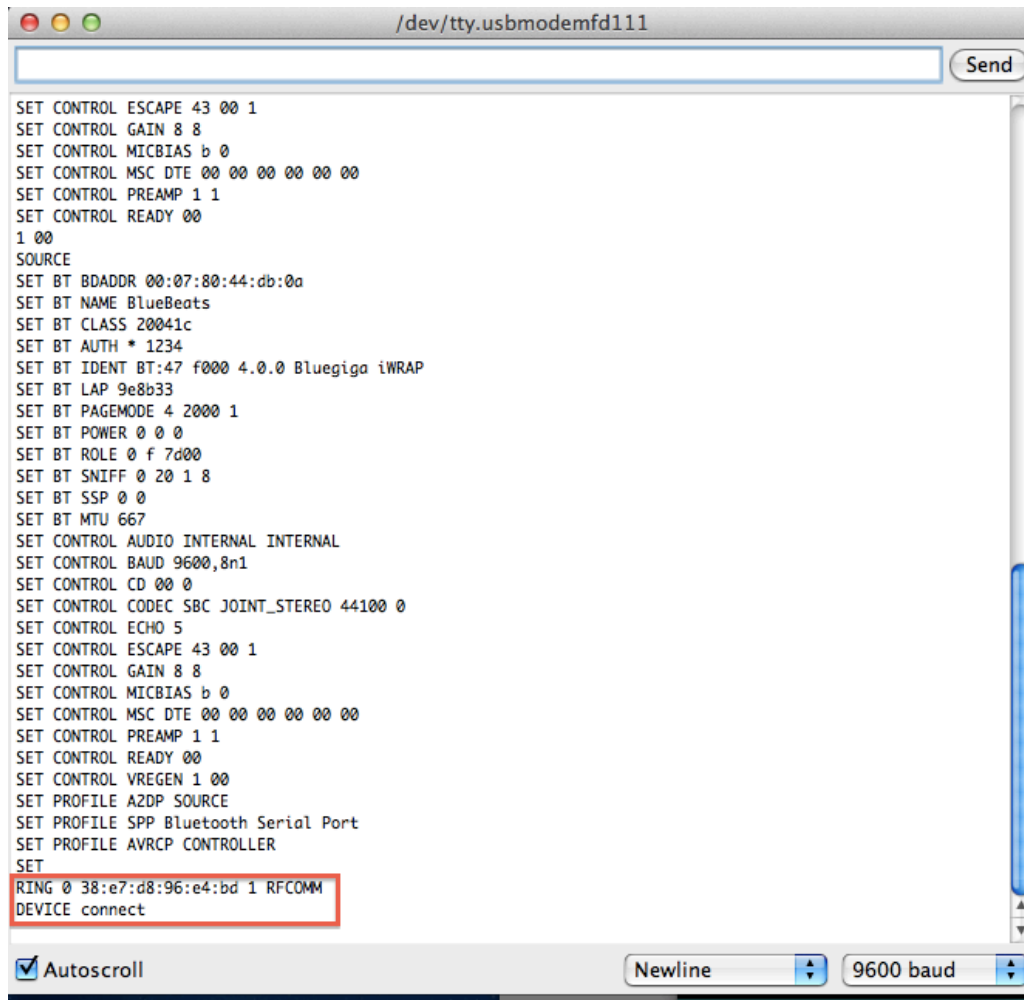

The image shows a terminal window titled "/dev/tty.usbmodemfd111". The window contains a series of AT commands for configuring a Bluetooth module. The commands include setting control parameters like ESCAPE, GAIN, MICBIAS, MSC DTE, PREAMP, and READY. It also sets BT parameters such as BDADDR (00:07:80:44:db:0a), NAME (BlueBeats), CLASS (20041c), AUTH (\* 1234), IDENT (BT:47 f000 4.0.0 Bluegiga iWRAP), LAP (9e8b33), PAGERMODE (4 2000 1), POWER (0 0 0), ROLE (0 f 7d00), SNIFF (0 20 1 8), SSP (0 0), and MTU (667). Audio-related settings include AUDIO (INTERNAL INTERNAL), BAUD (9600,8n1), CD (00 0), and CODEC (SBC JOINT\_STEREO 44100 0). The ECHO is set to 5. The terminal shows a second set of control parameters and BT settings, including the final command: "RING 0 38:e7:d8:96:e4:bd 1 RFCOMM" and "DEVICE connect". The "RING" command is highlighted with a red box. At the bottom of the window, there are controls for "Autoscroll" (checked), "Newline" (selected), and "9600 baud" (selected).

```
SET CONTROL ESCAPE 43 00 1
SET CONTROL GAIN 8 8
SET CONTROL MICBIAS b 0
SET CONTROL MSC DTE 00 00 00 00 00 00
SET CONTROL PREAMP 1 1
SET CONTROL READY 00
1 00
SOURCE
SET BT BDADDR 00:07:80:44:db:0a
SET BT NAME BlueBeats
SET BT CLASS 20041c
SET BT AUTH * 1234
SET BT IDENT BT:47 f000 4.0.0 Bluegiga iWRAP
SET BT LAP 9e8b33
SET BT PAGERMODE 4 2000 1
SET BT POWER 0 0 0
SET BT ROLE 0 f 7d00
SET BT SNIFF 0 20 1 8
SET BT SSP 0 0
SET BT MTU 667
SET CONTROL AUDIO INTERNAL INTERNAL
SET CONTROL BAUD 9600,8n1
SET CONTROL CD 00 0
SET CONTROL CODEC SBC JOINT_STEREO 44100 0
SET CONTROL ECHO 5
SET CONTROL ESCAPE 43 00 1
SET CONTROL GAIN 8 8
SET CONTROL MICBIAS b 0
SET CONTROL MSC DTE 00 00 00 00 00 00
SET CONTROL PREAMP 1 1
SET CONTROL READY 00
SET CONTROL VREGEN 1 00
SET PROFILE A2DP SOURCE
SET PROFILE SPP Bluetooth Serial Port
SET PROFILE AVRCP CONTROLLER
SET
RING 0 38:e7:d8:96:e4:bd 1 RFCOMM
DEVICE connect
```

Autoscroll      Newline      9600 baud

## 14.8 Appendix H: Solidworks Drawings

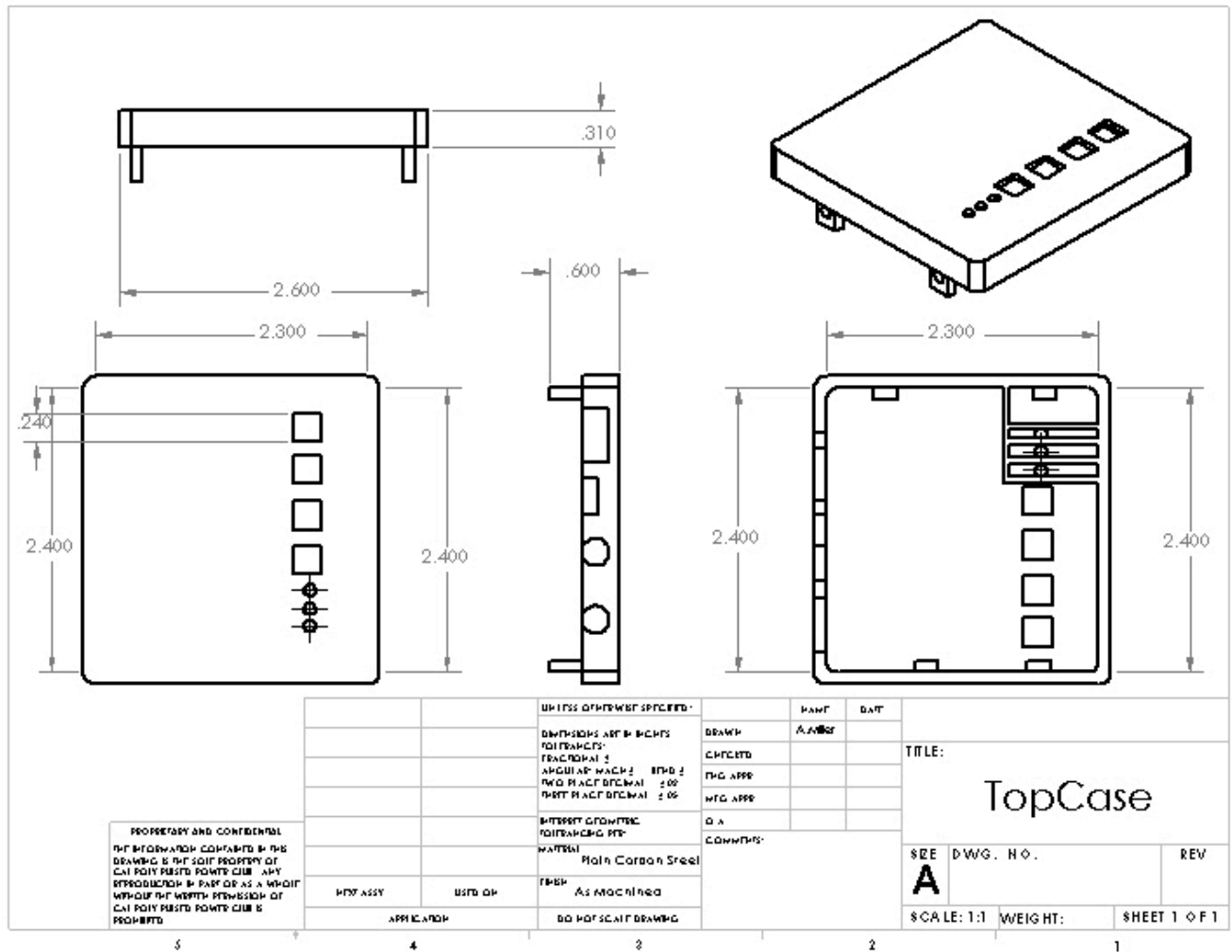



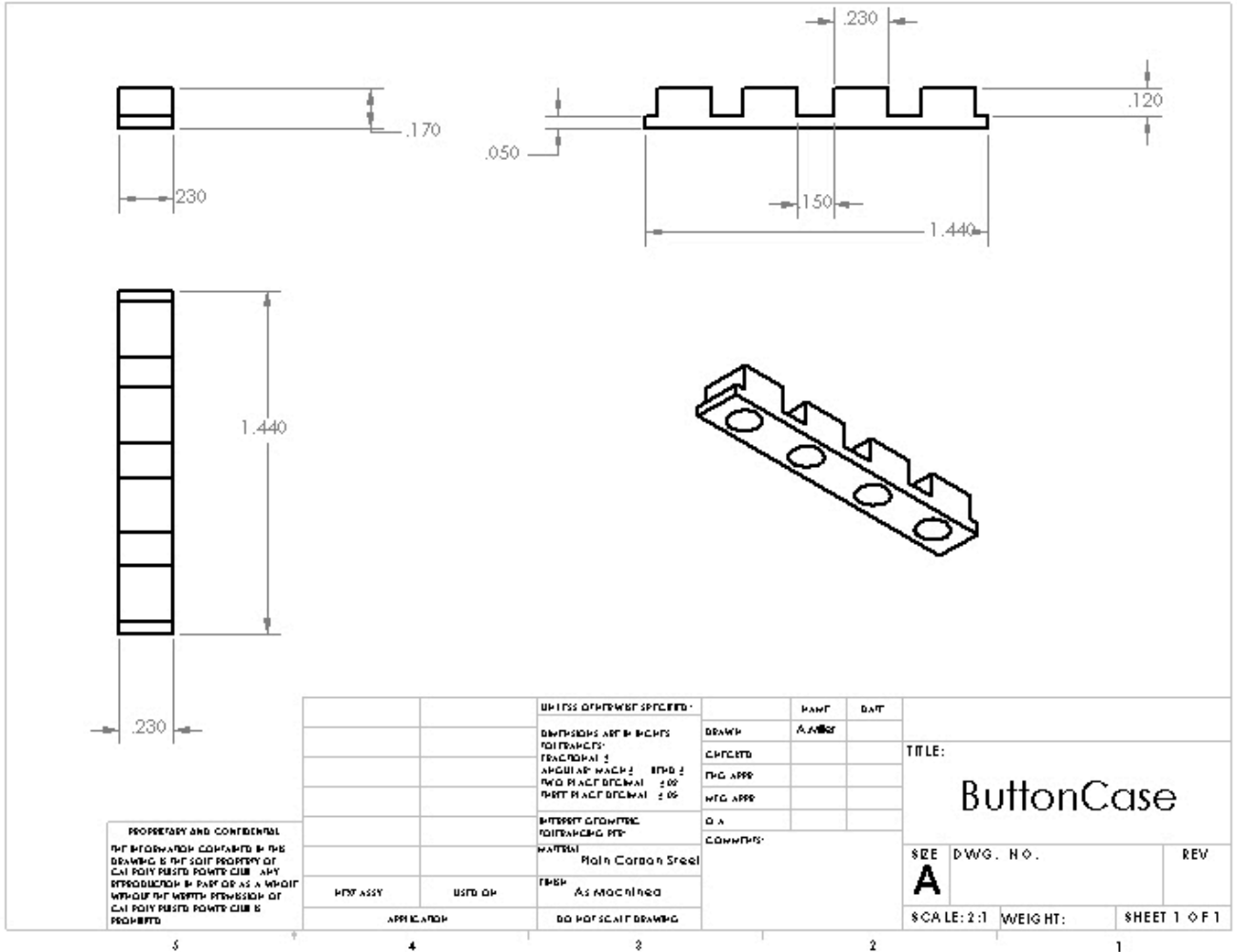

PROPRIETARY AND CONFIDENTIAL  
 THE INFORMATION CONTAINED IN THIS  
 DRAWING IS THE SOLE PROPERTY OF  
 CAL PONY PAPER PRODUCTS CO. ANY  
 REPRODUCTION IN PART OR AS A WHOLE  
 WITHOUT THE WRITTEN PERMISSION OF  
 CAL PONY PAPER PRODUCTS CO. IS  
 PROHIBITED.

		UNLESS OTHERWISE SPECIFIED:		DATE	
		DIMENSIONS ARE IN INCHES	DRAWN	A. JAMES	
		TOLERANCES:	CHECKED		TITLE:
		FRACTIONAL ±	ENG APPR		ButtonCase
		ANGULAR MAX ± .005	WTC APPR		
		ROUND PLACE DECIMAL ± .005	D.A.		SIZE DWG. NO.
		PERF. PLACE DECIMAL ± .005	COMMENTS:		REV
		MATERIAL			
		Hot Carbon Steel			
		FINISH			
		As Machined			
		APPLICATION			
		DO NOT SCALE DRAWING			