

# Ultra-Low Power Wireless Sensor Networks: Overview of Applications, Design Requirements and Challenges

Frederick Ojiemhende EHIAGWINA<sup>1,\*</sup>, Olufemi Oluseye KEHINDE<sup>1</sup>, Nurudeen Ajibola IROMINI<sup>2</sup>, Abubakar Siddiq NAFIU<sup>2</sup>, Deepak PUNETHA<sup>3</sup>

<sup>1</sup>Department of Electrical Electronic Engineering, The Federal Polytechnic Offa, Offa, Kwara State, Nigeria

<sup>1</sup>Department of Electrical Electronic Engineering, University of Ilorin, Ilorin, Kwara State, Nigeria

[Frederick.ehiagiwna@fedpoffaonline.edu.ng](mailto:Frederick.ehiagiwna@fedpoffaonline.edu.ng), [okdecibel@yahoo.com](mailto:okdecibel@yahoo.com)

<sup>2</sup>Department of Computer Technology Engineering, The Federal Polytechnic Offa, Offa, Kwara State, Nigeria

[ajibolaforu2003@yahoo.com](mailto:ajibolaforu2003@yahoo.com)/[assidiq123@yahoo.com](mailto:assidiq123@yahoo.com)

<sup>3</sup>Department of Electronics and Communication Engineering, Tula's Institute, Dehradun, Uttarakhand, India

[er.punetha@gmail.com](mailto:er.punetha@gmail.com)

---

Corresponding Author: [Frederick.ehiagiwna@fedpoffaonline.edu.ng](mailto:Frederick.ehiagiwna@fedpoffaonline.edu.ng)

Date Submitted: 03/09/2018

Date Accepted: 18/10/2018

Date Published: 31/12/2018

---

**Abstract:** *Wireless Sensor Networks (WSNs) have received significant attention from various researchers in terms of its architecture, design, challenges and supporting technologies, and so on. Also, their applications to different aspect such as structural health monitoring, health care, precision agriculture, intelligent transport systems have been reported. Though, some authors have reviewed different aspects of wireless sensor nodes, including applications, this paper presents a short survey of selected literature from a pool of articles reporting application cases of ultra-low power WSNs published in 2010-2017. In this paper, specific design requirements for using ultra-low power sensor nodes were highlighted. In addition, existing solutions to challenges encountered when using WSNs for the selected applications were examined. This short survey will help readers and practitioners with scholarly resource needed for understanding the state-of-the-art in ultra-low power wireless sensor applications and offers insight into areas for further research. It will also help researchers to become aware of potential collaborators in future works involving WSNs.*

**Keywords:** *Elderly, fall detection, object tracking, precision agriculture, sensor nodes, WBANs, and wireless sensor network.*

## 1. INTRODUCTION

Wireless Sensor Networks (WSNs) comprise of many collaborating sensor nodes capable of sensing, computing and communicating sensed signals to a remotely located server. They are used to monitor several physical phenomena inclusive but not limited to the following: pressure, sound, heat, air pollution, and health status, in the environment of the sensor nodes. The sensed data is transmitted to a base station by cooperative capabilities of the sensor nodes. Figure 1 shows a functional block diagram of a wireless sensor node, consisting of the following components: sensing subsystem including one or more sensors incorporating a transducer and analog-to-digital converters for data acquisition. Other subsystems are processing subsystem inclusive of a microcontroller and

memory for local data processing, radio subsystem for wireless data communication between nodes and base station, and power supply and storage unit. In addition, sensor nodes may also include components (not shown in the figure) such as a location finding unit to determine their position, a mobilizer to change their location or configuration (e.g., antenna's orientation), and so on.

Owing to their miniaturized size, nodes have limited resources such as computation speed, memory capacity, battery power, and bandwidth. For instance, in actual deployment, computation speed and or data rate may be traded off for battery power and vice-versa depending on the application. For power critical application, an ultra-low WSN incorporating energy harvesting module may be necessary.

Moreover, nodes should be capable of self-organization into a network infrastructure, with information retrievable via queries retrieved from the base station. Self-organization will allow for turned ON nodes to form a network and set up

routes with no external intervention. This is necessary, since in certain applications, technical expertise may not be available.

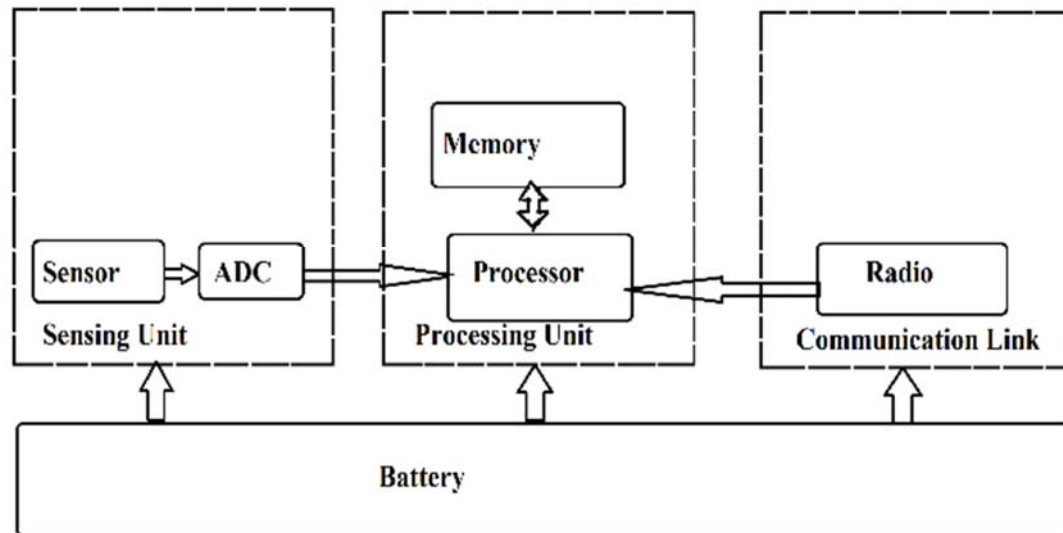

Figure 1: Block diagram of a wireless sensor node

There are numerous applications of sensor nodes reported by researchers. In addition, several articles have been written to survey different aspects of wireless sensor networks. Specific examples of survey articles on WSNs include the works of Alemdar and Ersoy [1], and Latre *et al.* [2] discussing applications health care and WBANs in 2010 and 2011 respectively. In 2012, Durisic *et al.* [3] examined applications to military, and in 2014, Borges and Co. [4] characterized and classified wireless sensor networks application.

In this short survey, some literature randomly selected from a pool of existing papers reporting applications of wireless sensor nodes with emphasis on ultra-low power applications was performed to give a quick view of the state-of-the-art to upcoming researchers in this field and industry experts in wireless sensor-based automation. The literature search was limited to articles published between 2010 and 2018. There are about 19,000 articles related to wireless sensor network on [ieeexplore.org](http://ieeexplore.org) alone.

Also, in this quick survey requirements for each application were highlighted along with the associated challenges. Where possible, a block diagram showing the application scenario is provided. The taxonomy of this paper is shown in Figure 2.

The rest of this article is sectioned as follows: Section 2 presents an overview of literature reporting applications of ultra-low power wireless sensor nodes in the biomedical field. Applications to non-medical areas are presented in Section 3. Finally, areas for future research are presented in Section 4.

## 2. WIRELESS SENSOR NETWORKS FOR BIOMEDICAL USES

A major area where wireless sensor network has been applied is in biomedicine, which can help to monitor vital signs such as heartbeat, motion, body temperature, pH, oxygen saturation, respiration, and so on with a potential reduction in cost, increase in convenience and saving life. Body Sensor Network (BSN), Wireless Personal Sensor Network (WPSN) and Wireless Body Area Networks (WBANs).

In this paper, attention is paid to WBANs, which are wireless networks that permits the full exploitation of wireless sensors and complementary technologies in healthcare system. They comprise of miniaturized intelligent devices attached on or surgically implanted in the body capable of establishing a communication link, to provide real-time feedback to medical experts or user. With WBANs, patients can be alerted via text message, alarm, and precautionary/curative treatment can be given automatically [9]. Other WBANs could be used in the treatment or monitoring of gastrointestinal tract [10], cancer detection and myocardial infarction [8], to monitor asthma, diabetics, heart attack [11] and fall detection and activity recognition in elderly care. In addition, it can be used to assess soldier fatigue and preparedness for battle. The architecture of the WBAN system is shown in Figure 3.

WBANs should consider the following requirements: (a) *Transmission power*: WBANs should transmit very low power so as to minimize interference and radiations, with potentially harmful effect on the body tissue. However, this

power should be enough to overcome the attenuation effect of body tissues.

(b) *Power Consumption:* In an effort to minimize power consumption of body area networks, a cross-layer communication protocol that consumes low energy may be necessary for WBANs since the sensors can sleep in slots where they are not communicating. Implanted WSN should be able to communicate with the external base station located outside the body to ensure efficient energy consumption, so that the system can operate for years, thus avoiding frequent surgical operations. Thotahewa et al [5] evaluated the complexity of design, power efficiency, etc. of Media Access Control (MAC) protocols based on UWB

proposed for WBANs. Bachmann [12] proposed low-power sensor nodes for a biomedical application capable of autonomous operation, by optimizing the digital signal processing circuitry and radio data reception and transmission.

(c) *Robust design:* WBANs should be robust to constant changes in network configuration, since the user or wearer can be in motion. Communication of WBANs requires energy efficient and highly reliable designs while keeping delay, low [6], [7]. Other requirements for using WBANs include data reliability, security, and privacy, complex and real-time data processing, image identification, etc.

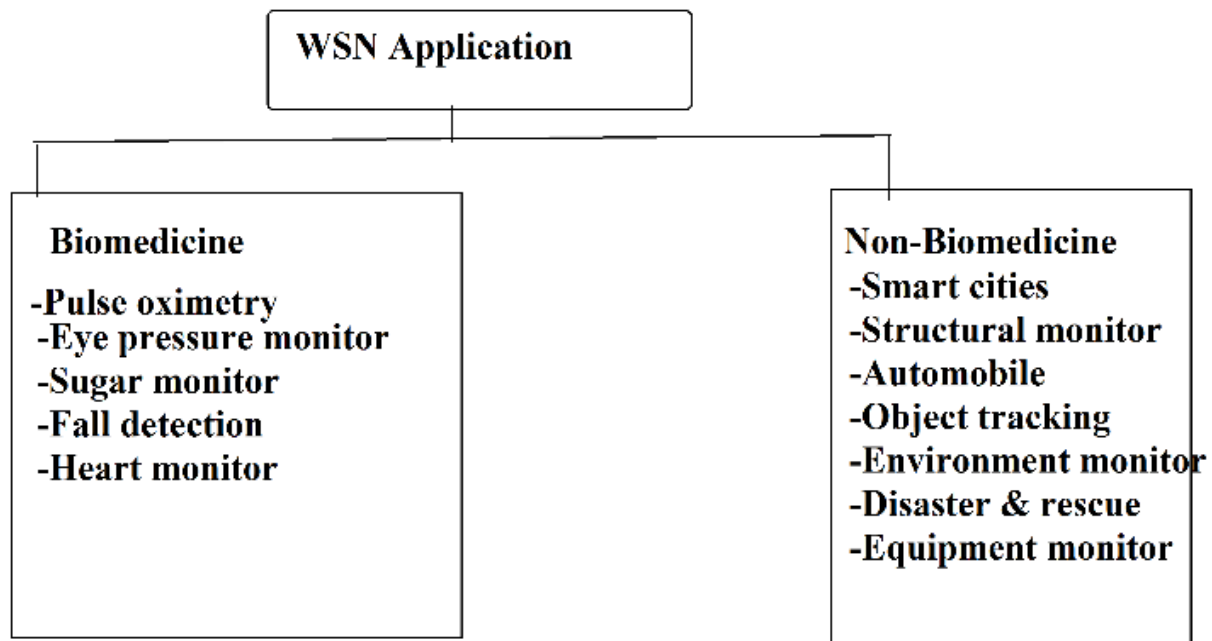

Figure 2: Taxonomy of wireless sensor networks applications

(d) *Long battery life:* Since these sensor nodes are attached to the body frequent battery replacement will result in discomfort. Therefore, ultra-low power operation is essential in this field of application.

(e) *Security and privacy:* Security and privacy-preservation are important issues that must be addressed when deploying wireless body area network for healthcare management. Privacy should be preserved both in data content (e.g. blood sugar level, heart rate, etc.) and context information such as locations of sensors.

(f) *Biocompatibility and ergonomics* have a direct bearing on human safety and comfort. Biocompatibility is a property

of a substance being compatible with living tissue, in terms of zero toxicity and immunological response. Whereas, ergonomic design of WBANs are intended to maximize productivity by reducing fatigue and discomfort. User comfort, which depends on the sensor form factor has to be given serious consideration when designing WBANs. What is more, the form factor is dependent on the battery size and power consumption of the system. Very comfortable WBANs are necessary because the trend is shifting away from hospital-centric healthcare service to person-centric and proactive care delivering with a potential reduction in the cost of health services.

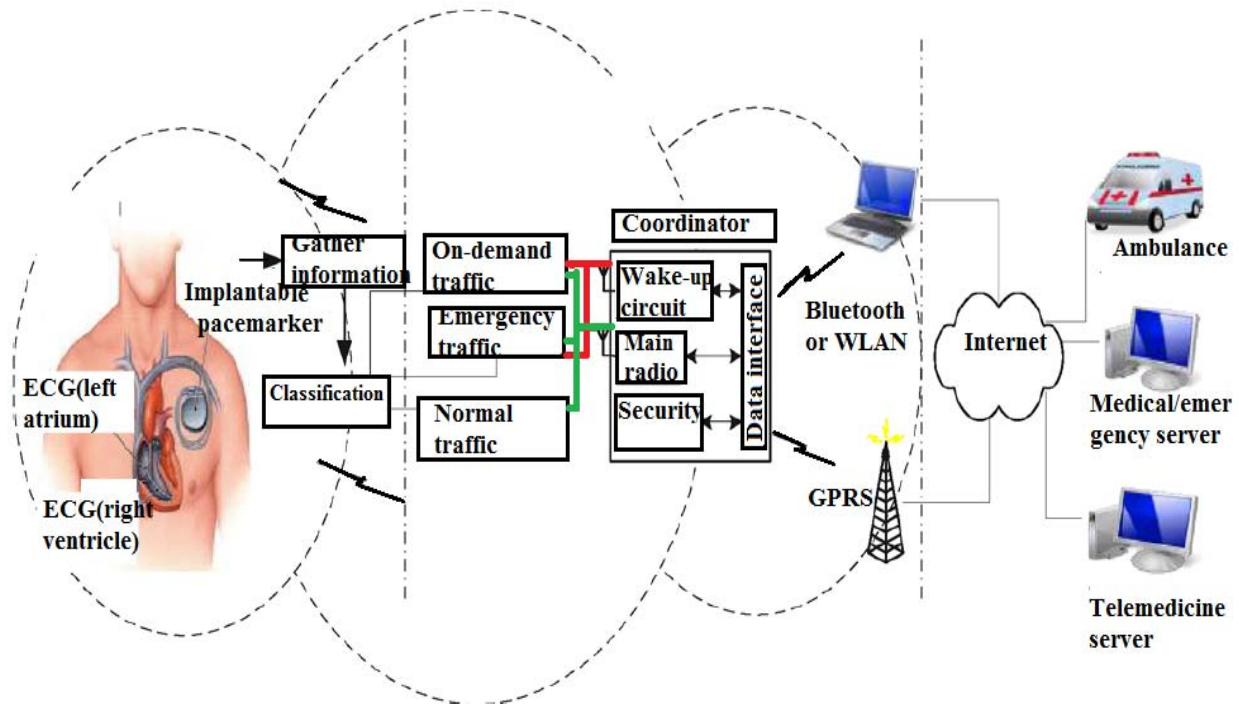

Figure 3: WBAN architecture for health services [8]

A review of the application, technical and functional requirement of WBANs was reported in [9]. In that paper, research issues such as very low pair-to-pair latency, biocompatibility, safety, scaling of the duty cycle, data rate and power consumption were considered. Other issues reviewed include ergonomic assessment of WBANs, Quality of Service (QoS), interference mitigation, efficient antenna design, privacy/security issues, coexistence with other technology and reliability.

(g) *Self-organizing feature*: In designing body area networks, consideration must be given to sensitivity and self-calibration especially under harsh conditions (fire, hot temperature, sweating body), which can affect node transducers. Several sensors may be needed to accurately capture vital signs leading to more data generated. Therefore, data rate, system bandwidth, and energy efficient data acquisition system must be given adequate consideration. Sensors may operate at different frequency level, and as such system designers have to consider interoperability and system isolation requirements. Apart from WBANs being capable of self-organization, they should have self-maintainability since they are usually set up on a patient by medical personnel who are neither computer scientist nor engineers.

Other requirements include; reliable communication, device portability, real-time availability, obtrusiveness, multi-hop routing, energy efficiency, and scalability, context-awareness, etc. are critical design requirements that must be considered with varying degree of importance according to a specific application requirement. The following discussion highlights some recent examples of deployment of WSNs in the biomedical sphere.

### 2.1. Care of the Elderly

Globally, the number of those above 65 years is rapidly increasing, thank to advancement in science and technology. Fall event among these individuals results in several cases of injury, with some being fatal. An elderly with the risk of falling can be instrumented with a wireless sensing device to detect and analyze body movements continuously. The device is capable of triggering an alarm when a fall is detected. Acceptable fall detection scheme must incorporate measures to respect the privacy and dignity of the elderly. In addition, the data gathered must be secured from those with malicious intent. The sensor node should be both small in size and light in weigh, to enhance user comfort.

A taxonomy of some fall detection technologies, with their merits and demerits, is shown in Figure 5. Jin *et al.* [13] observed that fall detection schemes require specificity, sensitivity, and accuracy. Zhenhe *et al.* [14] developed a fall detection system based on a 3-axis accelerator sensor worn on the waist. The sensor is capable of measuring velocity, shift, and tilt of the aged, and transmit observed data to a remote monitoring unit. In the remote monitoring unit, data are pre-processed using one-class Signal Vector Magnitude (SVM) classification algorithm. Then, the system adjudges whether or not falling has occurred using the difference in energy consumption of the human body action and a threshold value. An ADXL345 chip 3-axis digital accelerometer with multiple measuring ranges, 13 bits resolution and current rating of 40-145  $\mu$ A were used. Figure 4 shows the architecture of ADXL345. Detailed specification of this chip is found in [56].

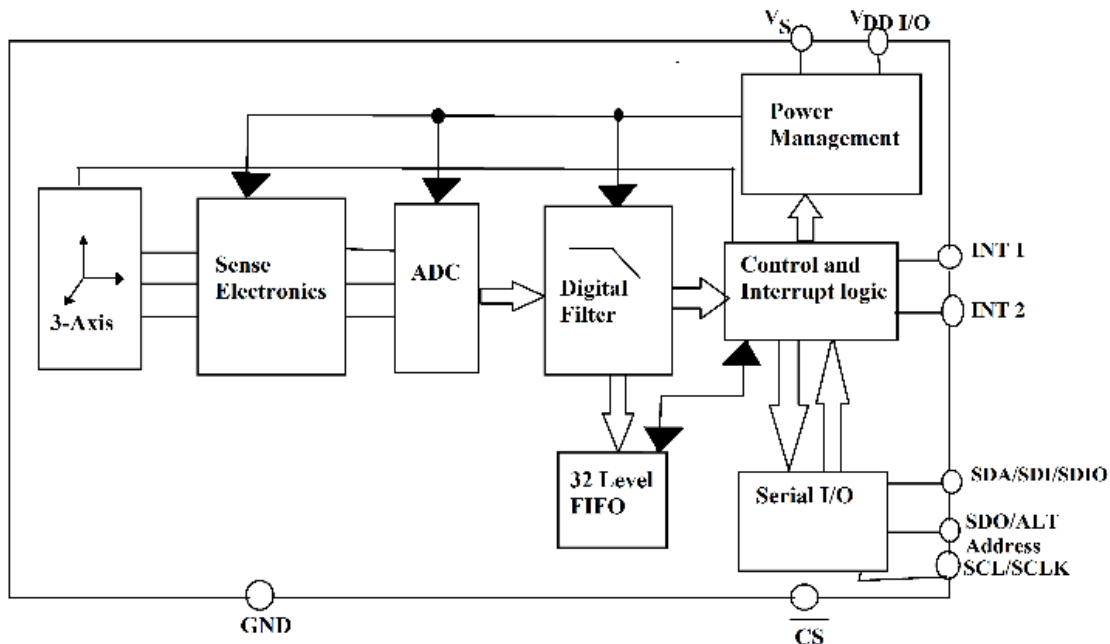

Figure 4: Block diagram of ADXL345. Redrawn from [56]

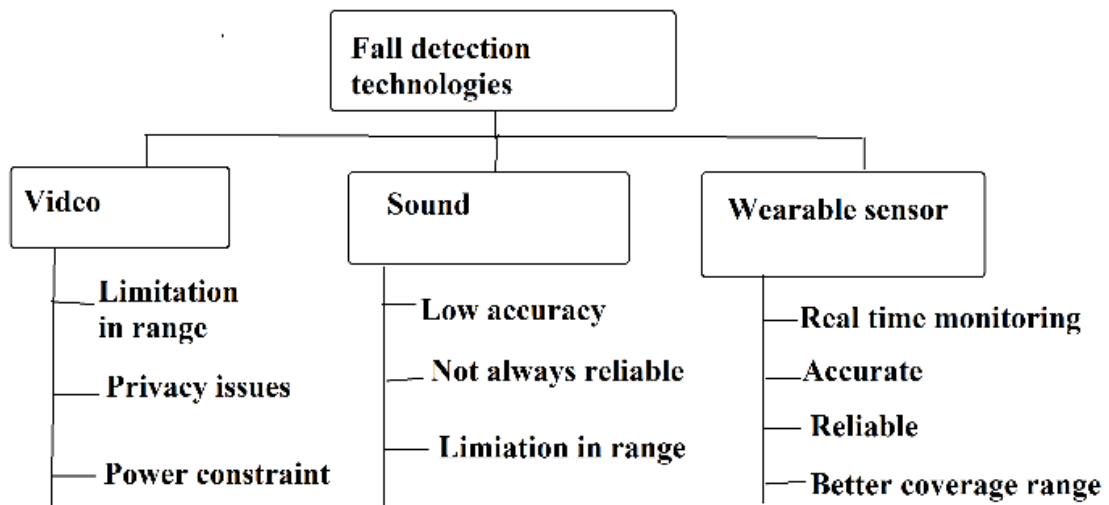

Figure 5: Some technologies for detecting falls

In [13], a similar scheme based on accelerometer sensor was developed, albeit complemented with humidity and temperature sensors. Meanwhile, Ransing and Manita [15] presented the development of smart or automated home, in which home parameters can be measured and adjusted. Several sensors are deployed to measure temperature,

contact, closing and opening of doors, and gas leakage.

Figure 6 show the connection of sensors in the proposed smart home. Data collected from these sensors are sent via ZigBee (XBee) to a remote unit, from where it will be processed and sent as a short message service to the caregiver.



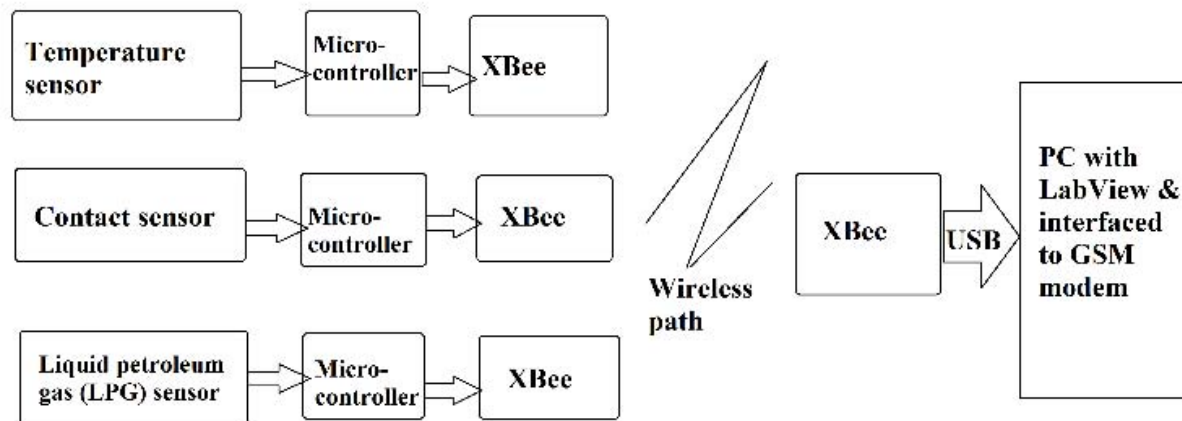

Figure 6: Block diagram of the smart home for supporting the elderly (adapted from [15])

ZigBee was used because it allows for low data rate, longer lifetime, good sensitivity and range, although with less throughput. Furthermore, integrating sleep/wake up schedule into the smart home system can greatly extend the lifetime of the nodes.

In elderly who are ill, cognitive abilities may be impaired with medication compliance being low. For good health care management of persons in this category, WSNs can be used to monitor the intake of medication. WSNs can be used to determine when and which medicine bottle is assessed, and the quality of medicine removed. The patient can be alerted to take their pills as at when due and also set mechanism in place for the purchase of decreasing medicine [1]. This could be via Short Message Service (SMS) notification.

## 2.2. Intraocular Eye Pressure Monitor

Intraocular Pressure (IOP) refers to the tissue pressure within the eye, determined by the level of production and drainage of aqueous humor. The typical IOP value range is  $10 \text{ mmHg} \leq \text{IOP} \leq 22 \text{ mmHg}$ . Increase in eye pressure is responsible for many eye defects such as glaucoma, which slowly and gradually results in blindness because the increased eye pressure damaged the optic nerve. Close to 70 million persons are affected worldwide [16]. By occasionally, going to the clinic for testing, one may not be able to note the peak pressure value that may occur during sleep at night [17]. Therefore, continuous monitoring of IOP is desirable.

One could use tethered and wired sensor or wireless sensor node as possible solution. But user comfort should be of paramount importance. The sensors should consume ultra-low power to prevent unnecessary battery replacement, as noted by researchers from Stanford University [18], pressure sensor miniaturization results in less trauma for the patient. They also observed that tethered and wired sensor solution is beset by constraint in frequency. Wireless contact lenses, an example of wireless sensor nodes is a viable means to continuously monitor eye physiological parameters.

Requirements of desirable wireless contact lens include [19]: (a) the need to maintain reliability despite several eye blinks, (b) flexibility and stretchability to enhance comfort,

and (c) optical transparency, so as not to obstruct vision. Another important requirement is (d) biocompatibility that is the materials used and their constituents must be harmless to the eye after mixing with eye physiological parameters like tear, and glucose.

Previously existing Micro-Electro-Mechanical Systems (MEMS)-based IOP sensors based on capacitance measurement are opaque and rigid. Chen *et al.* [20] reported an  $1.5 \text{ mm}^3$  intra-ocular eye pressure monitor implantable in the eye of a person having glaucoma. To power itself, the sensor scavenges solar energy that gets to the eye since the sensor consists of a  $0.07 \text{ mm}^2$  sized solar cell. With 10 hours of indoor light or  $1 \frac{1}{2}$  hours of daylight, the sensor could achieve lifetime operation. The authors in [17] developed a lens with a frequency response of  $8 \text{ kHz/mmHg}$  capable of sensing corneal curvature deformation. Zeng *et al.* [21] presented a graphene-based lens, where the graphene act as a capacitor connected in series with the copper coil, resulting in LC tank resonant coil. The authors in [19] developed a transparent and stretchable contact lens from graphene hybridized with metal nanowires, which were integrated into RLC circuit operating at radio frequency.

The eye contact lens can also be used to monitor the blood sugar level, rather than frequently collecting blood samples. It could also be good in helping some patients who are not fully compliant with treatment.

Through the microchip embedded on the concave side of the lens, the glucose the wearer's tears are analysed and the data communicated to the mobile phone or Personal Computer (PC) of the wearer. This could potentially lower the cost of diabetes management, although, the reliability of using tears for diabetes monitoring is still in its conceptual stage. External factors like environment, temperature and humidity may impact negatively on the accuracy of the glucose measurement [54]. Examples of studies in this regard are highlighted next. Badugu *et al.* [55] presented the use of a glucose-sensitive Silicone HydroGel (SiHG) contact lenses. Firstly, the authors used water and pure silicone present in the SiHG using polarity sensitive probe. Secondly, a glucose-sensitive fluorophore Quin-C18 with hydrophobic side chain for localization of probes at the interface region was synthesized. From the research, it was concluded that

fluorophore Quin-C18 is a potential material needed to a contact lens for continuous glucose monitoring, since the lense showed a similar response to glucose after about 90 days of preservation in water.

### 2.3. Heart Rate Monitor

For persons who either engage in stressful activities, or are having a cardiopulmonary disorder, regular heart rate monitoring is crucial. A complete and flexible sensor network for electromyogram (EMG)-for monitoring and assessing electrical activity generated by skeletal muscles, electroencephalogram (EEG)-for detecting medical problems connected with electrical activity of the brain, and electrocardiogram (ECG)-for monitoring the operations of the heart, built on SoC which incorporated adaptive power management technology such as the use of boost circuits, sub-threshold processing, less energy consuming transmitter and bio-signal front-ends, and body heat energy harvesting was developed in [11].

Maiolo *et al.* [22] reported on the use of the highly flexible and low cost PolyVinylidene FluorideTriFluoroEthylene (PVDF-TrFE) piezoelectric pressure sensor and strain-gauge sensor with high stretchability in a wearable wristband to monitor the heart rate and fine muscle movement of pilots.

### 2.4. Pulse Oximetry

The operation of a pulse oximeter is based on the difference in absorption pattern of red and infrared light of oxygenated and deoxygenated haemoglobin. Oxygenated haemoglobin permits more red light to pass through it and absorbs more infrared light. The reverse is the case for deoxygenated haemoglobin. Finger or toe is usually chosen with a photodetector at the other side to receive the light. Subsequently, the ratio of red to infrared is compared with a "look-up table" or calibration curve. Much will be done if a power dissipation of  $< 10 \mu W$  is to be realized. For instance, the energy consumption of the light source and detector will have to be lower. Furthermore, the mechanism for comparing the light sources and decision is yet another area where power management scheme may be included.

In [23], Tavakoli *et al.* applied an Ultra-Low Power (ULP) wireless sensor in pulse Oximetry used in the measurement of the percentage of oxygenated haemoglobin in the bloodstream of a patient. The use of a logarithmic trans-impedance amplifier, which does not require ADC and DSP-high energy consuming components, resulted in lower power dissipation of 4.8mW and a smaller chip size.

Madhav and Co [24] studied the extraction of respiratory activity from pulse oximeter Photoplethysmographic (PPG) signal using multi-scale independent component, thus presenting the use of an additional sensor. This will benefit patients with sleep and cardiopulmonary disorders. Previously existing devices for monitoring respiratory activity such as nasal thermistor and spirometer obstruct natural breathing.

Avakhkismi *et al.* [25] noted that the finger tissue has some complex features that negatively affects the efficient acquisition of PPG signal when sensors are not properly placed. Therefore, the authors developed a ring-shaped oximeter containing six sets of Light Emitting Diodes (LED)

and photodetectors evenly distributed around the finger, with the best light path used for the Oximetry.

## 3. WIRELESS SENSOR NETWORKS FOR NON-MEDICAL USES

This subsection of the paper examines applications of sensor nodes for non-medical purposes such as industrial machine diagnostics, chemical/biological detection, earthquake/volcano sensing, monitoring of civil structures, and Precision Agriculture (PA) [26]–[29]. This examination is in the context of whether or they qualify for ULP operations or not, and what can be done to make them qualify for such. Requirement for actual implementation are also outlined.

### 3.1. Structural Health Monitor (SHM)

Conceptually, in Structural Health Monitor (SHM), embedded sensors detect and analyse vibrations and shocks experienced by a given structure. Certain shocks are capable of causing significant damage within a short duration of time. It would require that structural engineers evaluate the extent of damage and structural integrity of the building at short notice and in most instances rely on visual inspections and their experience to make decisions, with potential influence on the post-disaster recovery process.

Visual observation is not always effective and time-consuming. Sensing system that monitors the level of vibrations that different parts of a building have been subjected to can assist in the assessment of the degree of damage suffered a structure, and the evaluators focus on the areas that have sustained the highest level of vibrations and stress [30]. Many implementations are based on strains experienced by an attached wire, which also transmit power to the sensors. During a high intensity vibrational-shock, the wires used in the connection may be severed or deformed, leaving the sensors without electrical power at this most critical moment when sensed data is highly needed. A possible solution is to use batteries, which, however, requires regular maintenance to replace the batteries. Most sensors locations can be difficult to reach. Another problem related to power is the need for SHM sensors to monitor fast time-varying vibrations and to carry out long distance metering. Therefore, the need for reliable power supply cannot be minimize.

However, the wireless implementation involving the use of wireless sensor nodes is gaining traction because it is not limited by the aforementioned constraints of wired sensor system. Some wireless sensor nodes integrate in their architecture energy scavenging scheme. If the operation of the wireless node is to be autonomous, they have to be operated on ultra-lower power sourced by incorporated vibrational or acoustic energy harvester. A sample of the numerous articles reporting the application of WSNs to SHM are reviewed next.

In [29], Wondra *et al.* presented a technique based on acceleration sensor nodes for Structure Health Monitor (SHM). The sensor nodes record the acceleration of the tower at different heights that are used to compute the magnitude and vibration frequencies experienced by the tower structure. In [27] passive wireless strain gauge was

used to limits of structural health monitoring systems based on wholly WSN or Radio Frequency Identification (RFID)-based sensors owing to its ability to cope with fast time-varying vibrations and carry out long distance metering. While Sabato et al [28] monitor the dynamic response of structures and machinery using MEMs. Cheng et al. [30] reported an event-driven energy-harvesting WSN for Structural Health Monitoring during an earthquake.

From the foregoing, there is the need to use highly flexible and stretchable piezoelectric materials like PVDF-TrFE in monitoring the health of structure in buildings located in environments with high seismic activities. To prevent closing bridges for routine inspections, the technics used in the reported works should be implemented. This will enhance the users' comfort and avoid economic loss.

### 3.2. Precision Agriculture (PA)

Precision Agriculture (PA) involves a collection of tools and practices required to accurately assess farming needs such as in irrigation and the amount of pesticide dosage required in response to inter and intra-field variability in crops [31]. PA may help to minimize expended resources and maximize yield. Under this application, sensor nodes may be used to detect the moisture and chemical content of the soil and plants, the data collected is then used to control irrigation switches, and to determine the type and quantity of fertilizer required. For example, urea detectors can be used to monitor soil to determine locations where cow have urinated on, thus saving the farmer the cost of purchasing urea for those spots in the farm.

In addition, precision agriculture provides low-cost assistance to fast-track the efficiency of agricultural cultivations, improving the environmental sustainability of the whole process and the quality of the production. In sustainability there are efforts to reduce the use of chemical agents such as pesticides [32] in order to better care for the environment.

Prior to deploying WSN for PA, the following requirements and application challenges must be considered.

(a) *Robust Packaging*: the package of the nodes must be water, and chemical resistant. This is owing to the fact that the sensors would be used in the agricultural field. It should be able to withstand outdoor temperature fluctuation over a long time period.

(b) *Effective Data aggregation scheme and Communication*: When applying sensor nodes in crop farming, there is the need to enhance connectivity to counter foliage attenuating effect. One way this can be done is to reduce the separating distance between two nodes. When performing field work (e.g. weeding) care must be exercised not to disturb the nodes. Finally, cellular network-based schemes are preferable to satellite or Wi-Fi based systems because of coverage and connectivity, and cost since SMS are generally very cheap to send.

Another issue encountered when designing a PA scheme, involves the management of the noisy data generated by the several nodes deployed in an agricultural field. As such,

appropriate data aggregation schemes are required to eliminate unnecessary data consequently reducing the power required to transmit sensor data and extending the battery lifetime. Furthermore, the mechanism for data acquisition must be energy efficient.

(c) *Power Source and Ultra-low Power Consumption*: In most cases farms are located in off-grid locations. Batteries may be used in powering the sensor nodes. These batteries must be capable of operating without replacement for a reasonably long period of time. When possible, energy harvesting schemes based on solar and wind energies may be incorporated. Literature on precision agriculture with reference to crop farming are examined next.

In [33], a survey on the application of WSNs to precision agriculture was presented. The authors discussed an application of sensor nodes to an automated irrigation system, controlled by Remote Monitoring Station (RMS) (Figure 8) and precision farming for a group of farmers in a cooperative society (Figure 9). The authors in [34] and [35] discussed WSN based PA cases for potato farm in Egypt and for irrigation management in Malawi respectively. The authors in [34] noted that sensor nodes could be used to map soil to reveal its location-specific features. While discussing the application of sensor nodes to irrigation management, Mafuta et al. [35] observed that when ZigBee and GPRS are used, one of these loses connectivity when the other is turned ON. The authors subsequently suggested an upgrade in the system's firmware. In order to address the challenge of unavailability of grid supply, solar energy harvesting scheme was integrated into the irrigation management system. In addition, by dividing the nodes into sub-networks, energy is conserved since no single node (acting as a hotspot) is used to collect all data from all other nodes. This harmonizes well with the suggestion of [34], who mentioned that network scalability can be achieved via a cluster based hierarchical network.

A good irrigation system will improve crop yield and lead to lush pasture for livestock. Livestock management can be enhanced by PA.

For example, an implanted body area sensor on livestock can monitor stomach acidity, fitness and digestion problems of animals. It may also be used to determine the best breeding time. However, since the animal may be in motion, the network topology and coverage may be fluctuating. Thus, routing protocol that can dynamically adjust to changing network topology is required. In addition, localization of the thousands of nodes that may be needed is usually a challenge in PA in terms of maintaining a balance between the accuracy of sensed data and energy consumption by the nodes. Received Signal Strength Indicator (RSSI) can be used to localize sensor nodes in an energy efficient manner, although they are prone to errors induced by variation in signal propagation. However, some systems use Global Positioning System (GPS) to determine the location of the nodes, to improve accuracy but at an additional cost both in terms of energy and hardware requirement and the network flexibility and robustness may be reduced.



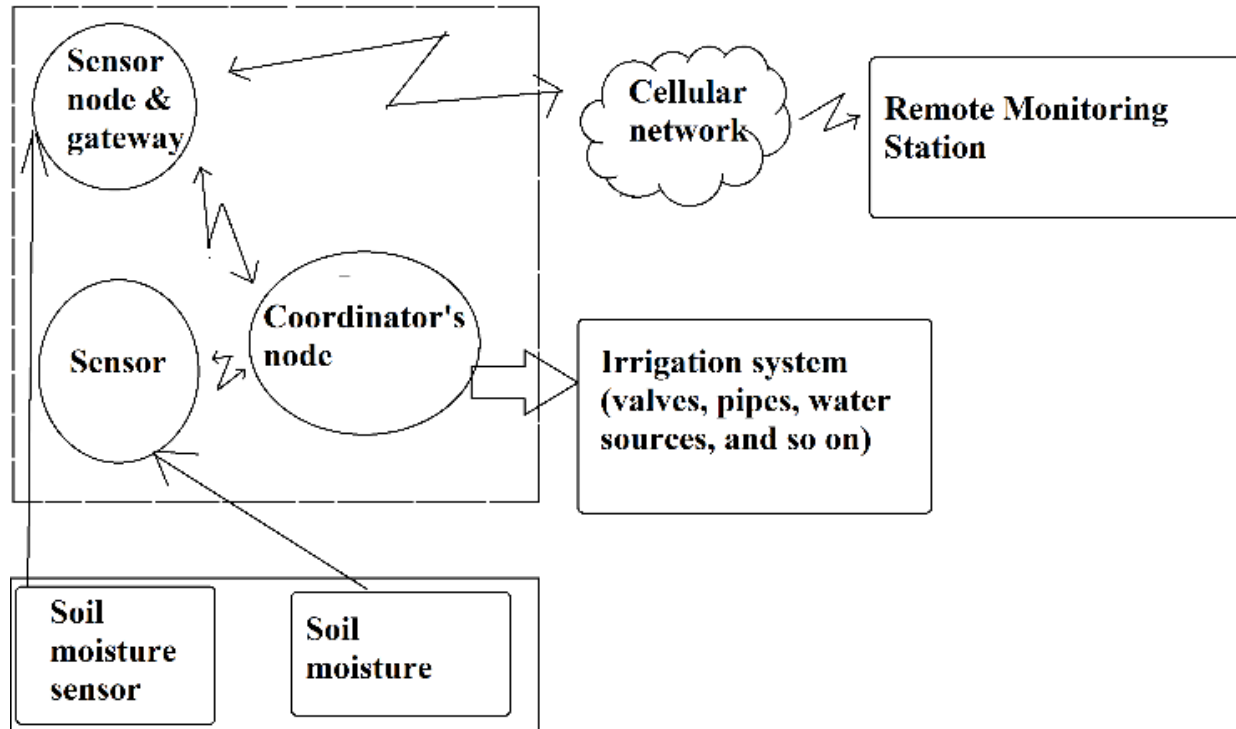

Figure 8: Architecture of irrigation management system. Redrawn from [33]

### 3.3. Transportation System

In transportation systems, sensors are needed for collecting traffic data for traffic planning and management, a major aspect in the ITS. Wired based ITS apart from cost and power consumption issues, can only be used in the monitoring of stationary vehicles, making them have limited flexibility. WSNs offers a low-cost wireless communication capability and decision process coupled with easy installation over wired sensors. Hence, WSNs are preferable in designing an Intelligent Transport System (ITS).

WSN based ITS usually involves the installation of three nodes (a) vehicle nodes-observes the parameters e.g. speed and location of the vehicle in which it is installed (b) roadside nodes, usually installed close to the roads collect traffic data from all vehicles nodes, and (c) the intersection nodes-receive data from roadside nodes for subsequent analysis. The processed information is transmitted to a base station for traffic management decision.

Transportation and smart cities researchers have demonstrated WSNs application in freight train derailment detection [36] and urban train transportation systems [37], and street parking [38]. In [39], sensor nodes were used in condition monitoring to detect and identify rail track degradation before an accident can occur as shown in figure 10. The real-time data they provide can be used by remote observers to make critical decisions, thereby reducing unnecessary downtime. Information gathered include temperature, humidity, wind and train speeds, and GPS coordinates.

Intelligent transport system is an essential requirement in the development of a smart city. The topology of the roads and buildings could potentially affect design considerations. Lin et al [38] studied the effects of different urban layouts on node energy consumption, amount of mesh routers deployed and sensing information delay to be factored in.

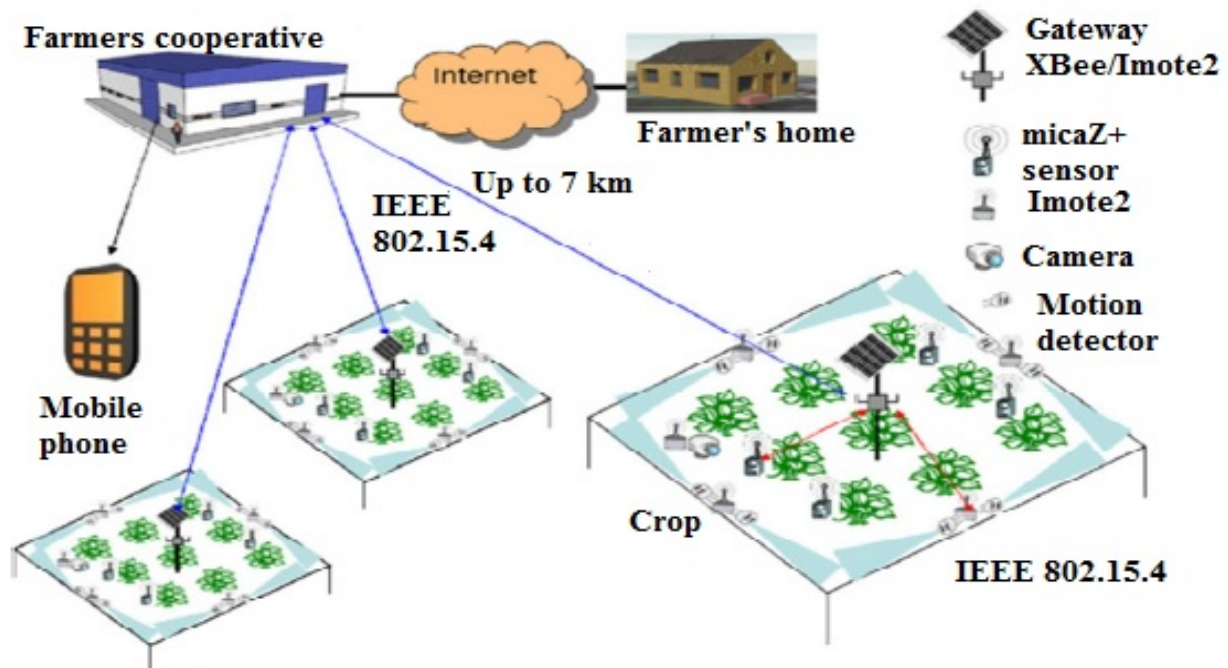

Figure 9: Precision agriculture coordinated by a farmer's cooperative society (sourced from [33])

*System Requirement and Challenges:* The quantity and quality of information depend on the type and amount of sensor nodes used in the condition monitoring scheme. Usually, a large amount of noisy and similar data are generated by the sensors. Also, implementation in harsh environment results in additional design challenges coupled with issues such as the provision of power and a higher probability of erroneous data transmission associated with the location of sensor nodes at a distance from the server. Consequently, a robust design should include appropriate data aggregation technique, energy harvesting scheme, data intrusion detection, and prevention schemes to prevent observers with malicious from assessing privacy-related data. Furthermore, a good design will prevent transmission errors, latency, missing or corrupted data and network outage.

### 3.4. Environmental Monitoring

Environmental sensor nodes sense light, humidity, temperature, fire, and air quality. Wired sensing schemes are not efficient in sensed data management and power consumption. In addition, wired sensor schemes require bulky hardware, subject to telemetry and bandwidth constraint. Traditionally used environmental monitoring data loggers may be expensive, time-consuming, and at the

same time their bulkiness limits flexibility. More so, it is not always possible to access locations where some sensor nodes are deployed. In contrast, wireless sensor nodes with specially designed packages can be used in chemical hazard monitoring, earthquake and volcanic eruption observation, flood detection, weather forecasting, air quality and content, glacier displacement measurement and natural habitat monitoring [40]–[44].

For instance, volcanic eruption monitors are used for detecting source mechanism, differentiate true eruption from noisy signals, and study the interior structure of the volcano. The sampling rate of volcanic time series data is done at 40 Hz or more, higher than other environmental monitoring schemes. To allow for ultra-low power operation, power control strategy such as triggering, and in-network event detection must be included in the monitoring scheme. There should be a synchronization of data from various nodes used, using GPS. Air pollution monitoring is complex since thousands of nodes may be deployed and there is a need to reduce data noisiness via appropriate data aggregation technique to eliminate duplicates and invalid results. In addition, data aggregation and compression will help in reducing power consumption when a large amount of data is transmitted between several nodes.

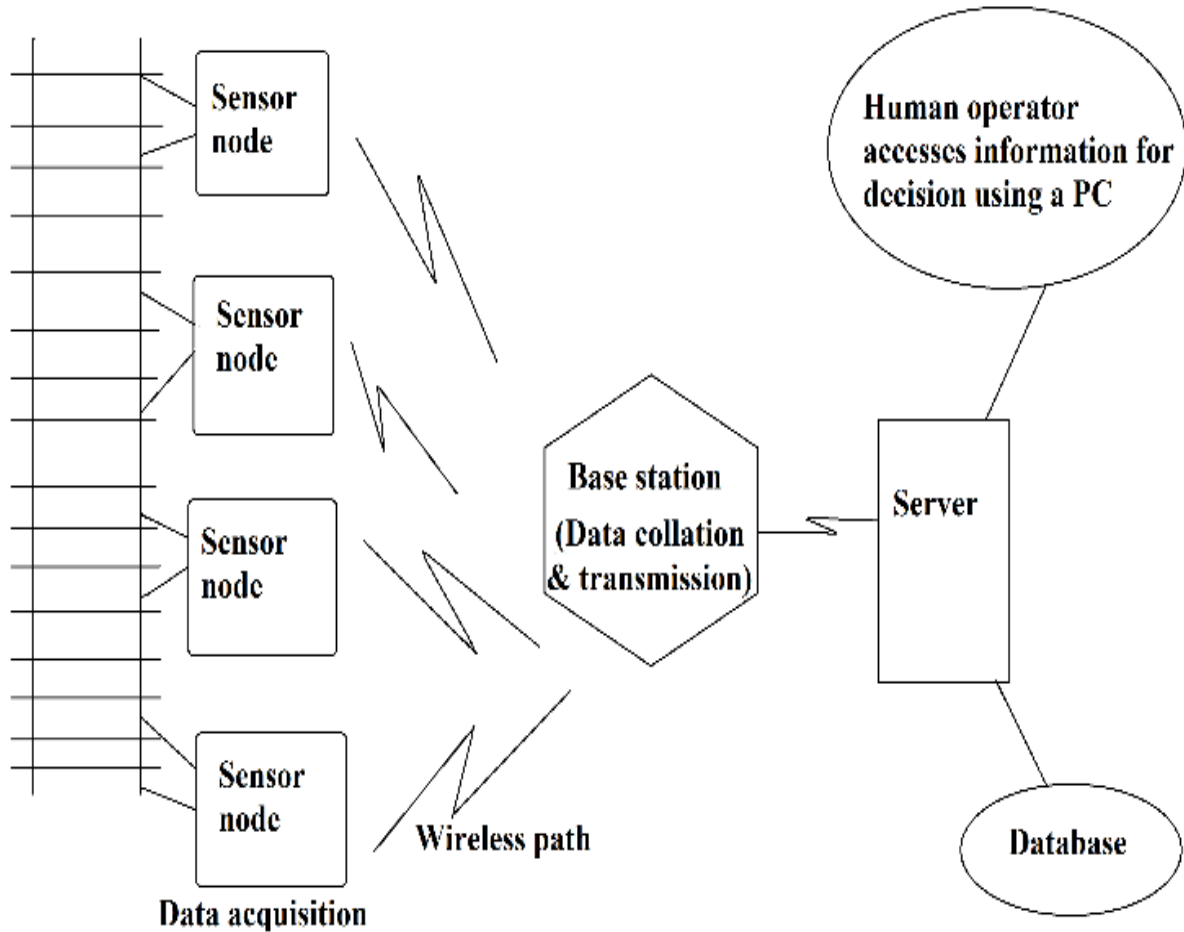

Figure 10: Typical WSN setup for railway condition monitoring. Sensor devices are mounted on boards attached to the object being monitored; examples include track, bridges, or train mechanics. Redrawn from [39].

Environmental monitoring systems require data archiving mechanism, internet access, long operating time, and energy efficient design. Monitoring of indoor air quality is essential for human health, safety, and general well-being. To determine air quality, gas sensors are used. Jelcic *et al.* [41], however, observed that commercially available gas sensor are power-demanding, and not energy efficient. To solve this problem, the sensor is put to sleep when to human is sensed in the room. The current drawn by the gas sensor during sleep mode is just  $8 \mu\text{A}$ . Human presence is detected using PIR. If the total time of operation of the sensor is  $T$ , the wake-up time and sleep time is  $t_{ON}$  and  $t_{OFF}$  respectively, then the average power consumed by the sensor is as shown in equation 1:

$$P_{av} = (P_{ON}t_{ON} + P_{OFF}t_{OFF})/T \quad (1)$$

But  $P_{OFF}t_{OFF}$  is very small, resulting in

$$P_{av} = P_{ON}t_{ON}/T \quad (2)$$

Equation 2 indicates that the average power consumed in a duty cycled operation is significantly reduced.

WSNs have been applied to monitoring industrial environments and machines for reasons such as aging of

many industries, the dynamic nature of the industrial sector, the high cost of installing and maintaining wired automation system and the need for a smarter automation system to enhance efficiency and productivity. However, there are issues with the deployment of industrial WSNs in the industries, including how to operate them in harsh industrial environments attributable to corrosive and caustic chemicals, humid and dusty air, electromagnetic compatibility issues, high level of vibration, and so on. Another challenge is associated with the non-standardized industry topologies. Also, in industrial environments, data communication is preferable because some sensor data are time sensitive to prevent damages and large-scale repair. For example, the automated fire extinguisher must activate as when demanded. In addition, technical challenges such as coordination of communications of large-scale deployment of sensor nodes have to be considered.

Other issues have to do with privacy/security requirement, internet connectivity, etc. so there is a need for monitoring systems that require little or no maintenance. In other words, the sensor nodes of the system should be autonomous or require very few battery replacements. While it is true that power source in an industrial environment might be

abundant, a robust monitoring scheme should be able to function for a reasonable amount of time even during shut down either for routine maintenance or other purposes. As such the sensor nodes should include an energy harvesting module or power storage unit, and other low power consuming components.

### 3.5. Disaster Management

Examples in this regard where WSNs is used to provide feedback and real-time data in disaster management and environmental monitoring include; human existence detection in the event of a disaster [45]. In disaster management, such as mountain rescue, a large amount of data and intensive communication at high frequency are usually involved. During a severe disaster, the mobile cellular network may be unavailable, and satellite communication may be the only communication option available. The implication is that onboard sensor should be capable of satellite communication. Other important requirements of sensor nodes meant for these purposes include robust packaging, resistance to humidity, good connectivity and coverage, etc. Available power should be conserved for possible a disastrous event by building into the network sleep/wake-up scheduler, with the current drawn during idle time as minimal as possible. Ivoghlian et al [46] developed a miniaturized sensor dissipating very low power for ubiquitous data acquisition. The sensor includes a power regulation scheme that contributes to longer operating time. Owing to the authors' intention of using the sensor in earthquake simulation experiments, the communication frequency and range are below 1 GHz and 11.7 km respectively. Pour et al [47] reported a microsystem, which scavenges solar energy used in operating very small hydrogen sensor autonomously.

Hydrogen as a fuel is non-pollutant, although it is explosive when mixed with oxygen. According to reference [48]: "*the use of hydrogen gas for combustion or any other purpose invariably requires a monitoring and controlling device to detect the hydrogen leakage and to alleviate the serious explosive danger*". The sensor of hydrogen sensor may be based on palladium/palladium alloy, optical fibre, Schottky diode, where a palladium-alloy gate is used. And in some cases, when a hydrogen molecule gets to the sensor a small voltage is generated, which is further amplified by on-chip amplifier. For an ultra-low power and autonomous operation, the energy consumption of the amplification and computation units must be given due consideration.

### 3.6. Automobile Monitor

Wireless sensor nodes mounted on car rim could be used in tire pressure sensing along with an Integrated Circuit (IC) designed to harvest energy and store same in a battery for onward usage. The data sensed can be used to enhance engine control, vehicle-to-vehicle communications, and object detection. According to Herndl [49], the requirements for a tire pressure sensor include (a) the mass of the entire sensor node, power supply and package inclusive should be <5g (b) strong package to withstand acceleration 3000 times that due to gravity (c) the size should not be > 1 cm<sup>3</sup>, so as

to prevent high force gradients due to device deformation, and (d) 10-year power supply lifetime.

Reshi and Co [50] introduced sensor node based vehicular pollution observing scheme called VehNode. VehNode is attached to the exhausts of vehicles and it examines the pollutants in vehicle smoke, compares the values with a given threshold and report any value out of the specified range to the car owner and the agency responsible for pollution control.

The current sensor nodes are drawn from the car battery when the car is parked and idle must be minimum. Some nodes come with embedded energy harvesting system. Since this involve automobile and communication could be disrupted, there is the need to implement a dynamic routing protocol and high data rate communication.

### 3.7. Object Tracking and Target Detection

Conventional surveillance technologies such as RADARS, though reliable and accurate are expensive and power hungry. Researchers have developed tracking systems that integrate cheap and decentralized WSNs. In general, a typical target tracking system should consider (a) data reporting mechanism (b) data quality-a function of the number of nodes and coverage (c) prediction/estimation algorithm, which must be distributed and lightweight e.g. Kalman filter, particle filter and mobile agent (d) activation mechanism, and (e) logical network [51], [52]. In addition, object or target detection can be achieved by the following: an image sensor, an acoustic sensor, passive infrared sensor.

Wireless sensor-based tracking systems are not limited by line of sight problem suffered by satellite-based systems, and so they can be deployed indoors. The deployment under this scenario requires collaboration among nodes, location awareness, identification and coordination, real-time processing, and a mechanism to evaluate a large amount of data frequently generated. For mobile objects, sensor node connectivity and coverage are always changing.

Meanwhile, "Boundary Recognition and Tracking algorithm for a Continuous Object (BRTCO)" for monitoring vehicle movement, forest fire, wild animals, and noxious gas, which have an irregular profile in terms of distribution were presented in [53]. Identification of continuous object requires the exchange of a large amount of data between several nodes. The authors reduced nodes' energy consumption by introducing collaborative boundary nodes filtering for eliminating redundant nodes, and efficient data reporting via cluster base reporting node selection scheme. Kalman filter and passive infrared sensor-based tracking systems only detect object but fail to identify the target. Therefore, Vasuhi and Vaidehi [52] proposed an Interactive multiple model Target Tracking WSN (ITTWSN), which uses velocity and acceleration models and several sensors to accurately detect and identify target.

But when several nodes are transmitting data, a robust data aggregation scheme is required to minimize the computations involved and the amount data transmitted. A good data aggregation scheme will further reduce power consumption.

#### 4. CONCLUSION

Issues involving privacy and anonymity of users trying to access real-time data of the wireless sensor nodes will need more attention since existing protocols are prone to denial-of-sleep attack. Also, in the application of WSNs to medicine and industries, how best can the sensitive and

confidential information be transmitted so as to prevent external intrusion? What additional roles will WSNs play in the emerging Internet of Things (IoT) paradigm? Solutions to questions like this will require more research efforts in order to enhance user's confidence and lead to more innovative applications.

Table 1: Summary of WSN applications and their design requirement/challenges

Applications of Wireless Sensor Networks	Design Requirements/Challenges							
	Privacy/ Security	Data aggregation	Ultra-low power operation	Flexibility	Ability to operate in harsh environment	Biocompatibility	Dynamic routing	High data rate and connectivity
Care of the elderly	✓		✓			✓		✓
Intraocular eye pressure monitor	✓		✓	✓		✓		
Heart rate monitor	✓		✓			✓		✓
Pulse oximetry			✓			✓		
Structural health monitor		✓	✓	✓	✓			✓
Pressure Agriculture		✓	✓		✓	✓	✓	
Transporation system	✓	✓	✓					✓
Environmental monitoring	✓	✓	✓		✓			✓
Disaster management	✓	✓	✓	✓	✓			✓
Automobile monitoring	✓				✓		✓	
Object tracking and target detection	✓	✓				✓	✓	✓

In this paper, we have reviewed wireless sensor networks in terms of design issues, applications to biomedicines and other fields. From this short survey, there does not seems to be legal or governance frameworks to regulate the deployment of WSNs. This survey will help readers and practitioners alike with scholarly resource needed for understanding the state-of-the-art in ultra-low power wireless sensors, and to see areas for further research. It will also help researchers to see potential collaborators in future works involving WSNs.

#### REFERENCES

- [1] H. Alemdar and C. Ersoy, "Wireless sensor networks for healthcare : A survey," *Comput. Networks*, vol. 54, no. 15, pp. 2688–2710, 2010.
- [2] B. Latre, B. Braem, I. Moerman, C. Blondia, and P. Demeester, "A survey on wireless body area networks," *Wirel. Networks*, vol. 17, pp. 1–18, 2011.
- [3] M. P. Durisic, Z. Tafa, G. Dimic, and V. Milutinovic, "A survey of military applications of wireless sensor networks," in *Embedded Computing (MECO), 2012 Mediterranean Conference on*, 2012, pp. 196–199.
- [4] L. M. Borges, F. J. Velez, and A. S. Lebres, "Survey on the Characterization and Classification of Wireless Sensor Network Applications," *IEEE Communications Surveys & Tutorials*, vol. 16, no. 4, pp. 1860–1890, 2014.
- [5] K. M. S. Thotahewa, J.-M. Redoute, and M. R. Yuce, "Medium access control (MAC) protocols for ultra-wideband (UWB)-based wireless body area networks (WBAN)," in *Ultra-wideband and 60 GHz communications for biomedical applications*, Springer US, 2014, pp. 131–152.
- [6] M. Z. Farooqi, S. M. Tabassum, M. H. Rehmani, and Y. Saleem, "A survey on network coding: From traditional wireless networks to emerging cognitive radio networks," *J. Netw. Comput. Appl.*, vol. 46, pp. 166–181, 2014.
- [7] J. Elias, "Optimal design of energy-efficient and cost-effective wireless body area networks," *Ad Hoc Networks*, vol. 13, pp. 560–574, 2014.
- [8] S. Ullah and K. S. Kwak, "An Ultra Low-power and Traffic-adaptive Medium Access Control Protocol for Wireless Body Area Network," *J. Med. Syst.*, vol. 36, no. 3, pp. 1021–1030, 2010.
- [9] M. Patel and J. Wang, "Applications, challenges, and prospective in emerging body area networking technologies," *IEEE Wirel. Commun.*, pp. 80–88, 2010.
- [10] C. Caffrey, K. Twomey, and V. Ogurtsov, "Development of a wireless swallowable capsule with potentiostatic electrochemical sensors for gastrointestinal tract investigation," *Sensors Actuators B Chem.*, vol. 218, pp. 8–15, 2015.
- [11] F. Zhang, Y. Zhang, J. Silver, Y. Shakhsher, M. Nagaraju, A. Klinefelter, J. Pandey, E. Carlson, A. Shrivastava, and B.



- Otis, "A Batteryless 19  $\mu$  W MICS / ISM-Band Energy Harvesting Body Area Sensor Node SoC," *IEEE J. Solid-State Circuits*, vol. 48, no. 1, pp. 3–4, 2013.
- [12] C. Bachmann, M. Ashouei, V. Pop, M. Vidojkovic, H. De Groot, and B. Gyselinx, "Low-power wireless sensor nodes for ubiquitous long-term biomedical signal monitoring," *IEEE Commun. Mag.*, vol. 50, no. 1, pp. 20–27, 2012.
- [13] W. Jin, Z. Zhongqi, L. Bin, L. Sungyoung, and S. R. Simon, "An enhanced fall detection system for elderly person monitoring using consumer home networks," *IEEE Trans. Consum. Electron.*, vol. 60, no. 1, pp. 23–29, 2014.
- [14] Y. Zhenhe, L. Ying, Z. Qiaoxiang, and L. Xue, "A Falling Detection System with wireless sensor for the Elderly People Based on Ergonomics," *Int. J. Smart Home*, vol. 8, no. 1, pp. 187–196, 2014.
- [15] R. S. Ransing and R. Manita, "Smart Home for Elderly Care , based on Wireless Sensor Network," in *2015 International Conference on Nascent Technologies in the Engineering Field (ICNTE-2015) Smart*, 2015, pp. 1–5.
- [16] D. Rathore, S. Shree, A. . Mukherjee, and S. Jameel, "Wireless measurement of intraocular pressure," *Int. J. Adv. Eng. Technol.*, vol. 7, no. 4, pp. 1342–1346, 2014.
- [17] G.-Z. Chen, I.-S. Chan, L. K. K. Leung, and D. C. C. Lam, "Soft wearable contact lens sensor for continuous intraocular pressur monitoring," *Med. Eng. Physic*, vol. 36, no. 9, pp. 1134–1139, 2014.
- [18] L. Y. Chen, B. C. Tee, A. L. Chortos, G. Schwartz, V. Tse, D. J. Lipomi, H. P. Wong, M. V Mcconnell, and Z. Bao, "Continuous wireless pressure monitoring and mapping with ultra-small passive sensors for health monitoring and critical care," *Nat. Commun.*, vol. 5, pp. 1–10, 2014.
- [19] J. Kim, M. Kim, M.-S. Lee, K. Kim, S. Ji, Y.-T. Kim, J. Park, K. Na, K.-H. Bae, H. K. Kim, F. Bien, C. Y. Lee, and J.-U. Park, "Wearable smart sensor systems integrated on soft contact lenses for wireless ocular diagnostics," *Nat. Commun.*, vol. 8, pp. 1–8, 2017.
- [20] G. Chen, M. H. Ghaed, R. M. Haque, M. Wiecekowsk, Y. Kim, G. Kim, D. Fick, D. Kim, M. Seok, K. D. Wise, and D. Blaauw, "A cubic-millimeter energy-autonomous intraocular pressure monitor," in *Solid-State Circuits Conference Digest of Technical Papers (ISSCC), 2011 IEEE International*, 2011, pp. 310–312.
- [21] P. Zeng, Q. Cui, M. Wu, P. Y. Chen, and M. M. C. Cheng, "Wireless and continuous intraocular presensor sensor using transparent graphene," in *2016 IEEE Sensors*, 2016, pp. 1–3.
- [22] L. Maiolo, F. Maita, A. Castiello, A. Minotti, and A. Pecora, "Highly wearable wireless wristband for monitoring cardiac activity and muscle fine movements," in *Metrology for Aerospace (MetroAeroSpace), 2017 IEEE Workshop on*, 2017.
- [23] M. Tavakoli, L. Turicchia, and R. Sarpeshkar, "An ultra-low-power pulse oximeter implemented with an energy-efficient transimpedance amplifier," *IEEE Trans. Biomed. Circuits Syst.*, vol. 4, no. 1, pp. 27–38, 2010.
- [24] K. V. Madhav, E. H. Krishna, and K. A. Reddy, "Extraction of respiratory activity from pulse oximeter's PPG signal using MSICA," in *Wireless Communications, Signal Processing and Network (WiSPNET), International Conference on*, 2016.
- [25] A. Avakhkisomi, A. Miled, M. Boukadoum, M. Morisette, F. Lellouche, and B. Gosselin, "N," in *Circuits and Systems (ISCAS), 2016 IEEE International Symposium on*, 2016.
- [26] T. Hamasaki, "Power management of autonomous wireless sensor node for structure health monitoring," *Analog Integr. Circuits Signal Process.*, vol. 75, no. 2, pp. 217–224, 2013.
- [27] E. DiGiampaolo, A. DiCarlofelice, and A. Gregori, "An RFID-Enabled Wireless Strain Gauge Sensor for Static and Dynamic Structural Monitoring," *IEEE Sensors Journal*, vol. 17, no. 2, pp. 286–294, 2017.
- [28] A. Sabato, C. Niezrecki, and G. Fortino, "Wireless MEMS-Based Accelerometer Sensor Boards for Structural Vibration Monitoring: A Review," *IEEE Sensors Journal*, vol. 17, no. 2, pp. 226–235, 2017.
- [29] B. Wondra, M. Botzand, and C. U. Grosse, "Wireless monitoring of structural components of wind turbines including tower and foundations," *Sci. Mak. Torque from Wind (TORQUE 2016) J. Phys. Conf. Ser.*, vol. 753, no. 7, p. 72033, 2016.
- [30] M. Cheng, Y. Chen, H. Wei, and W. K. G. Seah, "Event-Driven Energy-Harvesting Wireless Sensor Network for Structural Health Monitoring," in *38th Annual IEEE Conference on Local Computer Networks Event-Driven*, 2013, pp. 364–372.
- [31] F. Viani, M. Bertolli, and A. Polo, "Low-Cost Wireless System for Agrochemical Dosage Reduction in Precision Farming," *IEEE Sensors Journal*, vol. 17, no. 1, pp. 5–6, 2017.
- [32] R. A. de la Concepcion, R. Stefanelli, and D. Trincherro, "A Wireless Sensor Network Platform Optimized for Assisted Sustainable Agriculture," in *Global Humanitarian Technology Conference (GHTC), 2014 IEEE*, 2014, pp. 159–165.
- [33] M. H. Anisi, G. Abdul-salaam, and A. H. Abdullah, "A survey of wireless sensor network approaches farm fields in precision agriculture," *Precis. Agric.*, vol. 16, pp. 216–238, 2015.
- [34] S. M. A. El-kader and B. M. M. El-basioni, "Precision farming solution in Egypt using the wireless sensor network technology," *Egypt. Informatics J.*, vol. 14, no. 3, pp. 221–233, 2013.
- [35] M. Mafuta, M. Zennaro, A. Bagula, G. Ault, H. Gombachika, and T. Chadza, "Successful Deployment of a Wireless Sensor Network for Precision Agriculture in Malawi," *Int. J. Distrib. Sens. Networks*, vol. 2013, pp. 1–13, 2013.
- [36] M. Macucci, S. Di Pascoli, P. Marconcini, and B. Tellini, "Wireless sensor network for derailment detection in freight trains powered from vibrations," *2015 IEEE International Workshop on Measurements & Networking (M&N)*, pp. 1–6, 2015.
- [37] E. Aguirre, P. Lopez-Iturri, L. Azpilicueta, A. Redondo, J. J. Astrain, J. Villadangos, A. Bahillo, A. Perallos, and F. Falcone, "Design and Implementation of Context Aware Applications With Wireless Sensor Network Support in Urban Train Transportation Environments," *IEEE Sensors Journal*, vol. 17, no. 1, pp. 169–178, 2017.
- [38] T. Lin, H. Rivano, and F. Le Mouël, "Urban Infrastructure Deployment for Wireless On-Street Parking Sensor Networks," *Procedia Eng.*, vol. 115, pp. 29–36, 2015.
- [39] V. J. Hodge, S. O. Keefe, M. Weeks, and A. Moulds, "Wireless Sensor Networks for Condition Monitoring in the Railway Industry : A Survey," *IEEE Trans. Intell. Transp. Syst.*, vol. 16, no. 3, pp. 1088–1106, 2015.
- [40] D. Brunelli and M. Rossi, "CH4 monitoring with ultra-low power wireless sensor network," in *Lecture Notes in Electrical Engineering Vol. 289: Applications in Electronics Pervading Industry, Environment and Society*, A. De Gloria, Ed. Springer, 2014, pp. 13–25.
- [41] V. Jelcic, M. Magno, D. Brunelli, G. Paci, and L. Benini, "Context-Adaptive Multimodal Wireless Sensor Network for Energy-Efficient Gas Monitoring," *IEEE Sens. J.*, vol. 13, no. 1, pp. 328–338, 2013.
- [42] S. R. . . Prabhu, C. V. Dhasharathi, R. Prabhakaran, M. R. Kumar, S. W. Feroze, and S. Sophia, "Environmental Monitoring and Greenhouse Control by Distributed Sensor Network," *Int. J. Adv. Netw. Appl.*, vol. 5, no. 5, pp. 2060–2065, 2014.
- [43] W. Zhang, P. Passow, E. Jovanov, R. Stoll, and K. Thurow, "A secure and scalable telemonitoring system using ultra-low-energy wireless sensor interface for long-term monitoring in

- life science applications,” *2013 IEEE International Conference on Automation Science and Engineering (CASE)*, pp. 617–622, 2013.
- [44] Z. Mihajlovic, A. Joza, V. Milosavljevic, V. Rajs, and M. Zivanov, “Energy harvesting wireless sensor node for monitoring of surface water,” *2015 21st International Conference on Automation and Computing (ICAC)*, pp. 1–6, 2015.
- [45] G. Tuna, V. C. Gungor, and K. Gulez, “An autonomous wireless sensor network deployment system using mobile robots for human existence detection in case of disaster,” *Ad Hoc Networks*, vol. 13, pp. 54–68, 2014.
- [46] A. Ivoghlian, K. I.-K. Wang, Z. Salcic, and S. A. Catapang, “An ultra-low power miniaturised wireless mote for ubiquitous data acquisition,” in *Sensing technology: current status and future trends IV*, Springer International Publishing, 2015, pp. 139–169.
- [47] N. K. Pour, F. Krummenacher, and M. Kayal, “An ultra-low power energy-efficient microsystem for hydrogen gas sensing applications,” *Analog Integr. Circuits Signal Process.*, vol. 77, no. 2, pp. 155–168, 2013.
- [48] S. Basu and S. K. Hazra, “Graphene-based junction devices for hydrogen sensors,” in *Progresses in Chemical Sensor*, InTech, 2016.
- [49] T. Herndl, “Remote sensing of car tire pressure,” in *Energy harvesting systems*, T. J. Kazmierski and S. Beeby, Eds. Springer Science+Business Media, LLC, 2011, p. 141.
- [50] A. A. Reshi, S. Shafi, and A. Kumaravel, “VehNode: Wireless sensor network platform for automobile pollution control,” in *Information & Communication Technologies (ICT), 2013 IEEE Conference on*, 2013.
- [51] O. Demigha, W. Hidouci, T. Ahmed, and O. Demigha, “On Energy Efficiency in Collaborative Target Tracking in Wireless Sensor Network : A Review,” *IEEE Commun. Surv. Tutorials*, vol. 15, no. 3, pp. 1210–1222, 2012.
- [52] S. Vasuhi and V. Vaidehi, “Target tracking using Interactive Multiple Model for Wireless Sensor Network,” *Inf. Fusion*, vol. 27, pp. 41–43, 2016.
- [53] G. Han, J. Shen, L. Liu, and L. Shu, “BRTCO: A Novel Boundary Recognition and Tracking Algorithm for Continuous Objects in,” *IEEE Syst. J.*, vol. PP, no. 99, pp. 1–10, 2016.
- [54] J. Birch, “What happened to plans for a smart contact lens for diabetes,” *Labiotech*, 25 01 2018. [Online]. Available: <http://labiotech.eu/features/contact-lens-glucose-diabetes/>. [Accessed 02 09 2018].
- [55] R. Badugu, E. A. Reece and J. R. Lakowicz, “Glucose-Sensitive Silicone Hydrogel Contact Lens toward Tear Glucose Monitoring,” *Journal of Biomedicine*, vol. 23, no. 5, 2018.
- [56] Analog Devices, “ADXL345 Datasheet and Product Info,” 2018. [Online]. Available: <http://www.analog.com/media/en/technical-documentation/data-sheets/ADXL345.pdf>. [Accessed 3 09 2018].