



## Ozonation of semi-closed aquatic systems - Online control

Spiliotopoulou, Aikaterini

*Publication date:*  
2019

*Document Version*  
Publisher's PDF, also known as Version of record

[Link back to DTU Orbit](#)

*Citation (APA):*  
Spiliotopoulou, A. (2019). Ozonation of semi-closed aquatic systems - Online control. Kgs. Lyngby, Denmark: Technical University of Denmark.

---

### General rights

Copyright and moral rights for the publications made accessible in the public portal are retained by the authors and/or other copyright owners and it is a condition of accessing publications that users recognise and abide by the legal requirements associated with these rights.

- Users may download and print one copy of any publication from the public portal for the purpose of private study or research.
- You may not further distribute the material or use it for any profit-making activity or commercial gain
- You may freely distribute the URL identifying the publication in the public portal

If you believe that this document breaches copyright please contact us providing details, and we will remove access to the work immediately and investigate your claim.

# Ozonation of semi-closed aquatic systems - Online control

PhD Thesis

Aikaterini Spiliotopoulou  
February 2019

DTU Environment  
Department of Environmental Engineering

---

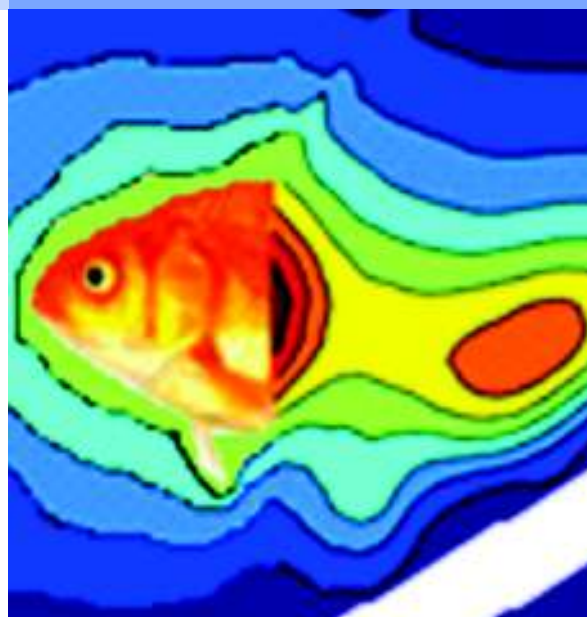

# Ozonation of semi-closed aquatic systems – Online control

Aikaterini Spiliotopoulou

PhD Thesis  
December 2018

DTU Environment  
Department of Environmental Engineering  
Technical University of Denmark

# **Ozonation of semi-closed aquatic systems – Online control**

**Aikaterini Spiliotopoulou**

PhD Thesis, December 2018

The synopsis part of this thesis is available as a pdf-file for download from the DTU research database ORBIT: <http://www.orbit.dtu.dk>.

Address: DTU Environment  
Department of Environmental Engineering  
Technical University of Denmark  
Miljoevej, building 113  
2800 Kgs. Lyngby  
Denmark

Phone reception: +45 4525 1600

Fax: +45 4593 2850

Homepage: <http://www.env.dtu.dk>

E-mail: [reception@env.dtu.dk](mailto:reception@env.dtu.dk)

Cover: GraphicCo

# Preface

This PhD thesis is submitted as a partial fulfilment to attain the Doctor of Philosophy degree (PhD). The research contained within this PhD thesis was carried out at the Department of Environmental Engineering, at the Technical University of Denmark and OxyGuard International A/S. It was conducted from January 2016 to December 2018 under the main supervision of Professor Henrik Rasmus Andersen (DTU Environment) and Paw Petersen (Co-owner and Director, OxyGuard International A/S) and the co-supervision of Richard Martin (CEO, Water ApS) and Lars-Flemming Pedersen (Senior Research Scientist, DTU Aqua).

The thesis is based on four scientific papers, which are referred to in the text by their paper number written with the Roman numerals **I-IV**.

- I** **Aikaterini Spiliotopoulou**, Richard Martin, Lars-Flemming Pedersen & Henrik R. Andersen. Use of fluorescence spectroscopy to control dissolved ozone in recirculating aquaculture systems. *Water research*, 111 (2017), 357-365.
- II** **Aikaterini Spiliotopoulou**, Paula Rojas-Tirado, Ravi K. Chhetri, Kamilla M.S. Kaarsholm, Richard Martin, Per B. Pedersen, Lars-Flemming Pedersen & Henrik R. Andersen. Ozonation control and effects of ozone on water quality in recirculating aquaculture systems. *Water research*, 133C (2018), 289-298.
- III** **Aikaterini Spiliotopoulou**, Henrik R. Andersen, Lars-Flemming Pedersen, Colin A. Stedmon & Adam Hambly. Resolving the reaction kinetics of ozone and organic matter in recirculating aquaculture systems using fluorescence EEM spectroscopy. *Manuscript*.
- IV** Paula Rojas-Tirado, **Aikaterini Spiliotopoulou**, Richard Martin, Henrik R. Andersen, Per B. Pedersen & Lars-Flemming Pedersen. Short Communication: Observations of ozone effects on RAS water. *Manuscript*.

In addition, the results of the thesis have also been presented in several international conferences:

- **Aikaterini Spiliotopoulou**, Richard Martin & Henrik R. Andersen. An innovative way to determine on-site ozone delivery efficiency, Oral Presentation at the 11th International Conference on Recirculating Aquaculture (ICRA) and 2016 Aquaculture Innovation Workshop (AIW), 19-21 August 2016, Roanoke, Virginia.
- **Aikaterini Spiliotopoulou**, Richard Martin & Henrik R. Andersen. A novel way to verify ozone dosing in the field, Oral Presentation at International Ozone Association-Pan American Group (IOA-PAG) Annual Conference & Expo, 28-31 August 2016, Las Vegas, Nevada
- **Aikaterini Spiliotopoulou**, Paula Rojas-Tirado, Kamilla M.S. Kaarsholm, Lars-Flemming Pedersen & Henrik R. Andersen. Prediction of required ozone dosage for pilot recirculating aquaculture systems based on laboratory studies - Study case, Oral Presentation at Conference on Environmental Science and Technology (CEST2017), 31 August- 2 September 2017, Rhodes, Greece.
- **Aikaterini Spiliotopoulou**, Paula Rojas-Tirado, Ravi K. Chhetri, Kamilla M.S. Kaarsholm, Richard Martin, Per B. Pedersen, Lars-Flemming Pedersen & Henrik R. Andersen. Optimum ozonation of freshwater pilot recirculating aquaculture system-Water quality, Oral Presentation at Nordic RAS, 12-13 October 2017, Aalborg, Denmark.
- **Aikaterini Spiliotopoulou**, Richard Martin, Lars-Flemming Pedersen & Henrik R. Andersen. Ozonation of recirculating aquaculture system based on system's demand, Oral Presentation at Aquaculture Europe 17, 17-20 October 2017, Dubrovnik, Croatia.
- **Aikaterini Spiliotopoulou**, Paula Rojas-Tirado, Richard Martin, Lars-Flemming Pedersen & Henrik R. Andersen. Determination of required ozone dosage in freshwater pilot recirculating aquaculture systems and ozone effect on water quality parameters, Oral Presentation at Aquaculture America 2018, 19-23 February 2018, Las Vegas, Nevada.
- **Aikaterini Spiliotopoulou**, Henrik R. Andersen, Lars-Flemming Pedersen, Colin A. Stedmon, & Adam C. Hambly. The response of fluorescent organic matter to ozone treatment in pilot freshwater RAS. Oral Presentation at Asian – Pacific Aquaculture 2018, 23-26 April, Taipei, Taiwan.
- **Aikaterini Spiliotopoulou**, Henrik R. Andersen, Lars-Flemming Pedersen, Colin A. Stedmon, & Adam C. Hambly. The effect of ozone on fluorescent

organic matter in pilot freshwater RAS. Oral Presentation at AQUA2018, 25-29 August 2018, Montpellier, France.

- **Aikaterini Spiliotopoulou**, Richard Martin, Lars-Flemming Pedersen & Henrik R. Andersen. Quantification of potential formation of ozonated by-products in saline pilot-RAS, Oral Presentation at Latin American & Caribbean Aquaculture 2018, 23-26 October 2018, Bogota, Colombia.

Additional publications, not included in this thesis, were also conducted along with the PhD study:

- Kai Tang, **Aikaterini Spiliotopoulou**, Ravi K. Chhetri, Gordon T.H. Ooi, Kamilla M.S. Kaarsholm, Kim Sundmark, Bianca Florian, Caroline Krage-lund, Kai Bester & Henrik R. Andersen. Removal of pharmaceuticals, toxicity and natural fluorescence through the ozonation of biologically treated hospital wastewater, with further polishing via a suspended biofilm. *Chemical Engineering Journal*, 359 (2019), 321-330.
- **Aikaterini Spiliotopoulou**, Maria G. Antoniou & Henrik R. Andersen. Natural fluorescence emission - an indirect measurement of applied ozone doses in polishing of pharmaceuticals wastewater. Submitted to *Environmental Technology*.
- Kai Tang, **Aikaterini Spiliotopoulou**, Kamilla M.S. Kaarsholm, Ravi K. Chhetri, Gordon T.H. Ooi, Kai Bester & Henrik R. Andersen. Ozone polishing of biological treated hospital wastewater for pharmaceuticals and toxicity. *Manuscript*.





# Acknowledgements

I would like to thank all my supervisors for the help, the encouragement and the guidance through this PhD study. More specifically, Henrik R. Andersen for the nice discussions over coffee, the constructive comments, the support all these years and for challenging me and pushing me out of my comfort zone, Richard Martin for the technical support and the assistance to set-up my system, Paw Petersen and Hans-Christian Kromand for the support and the opportunity they gave me to conduct this study and the pleasant company at conferences and exhibitions. Last but not least, Lars-Flemming Pedersen for the nice discussions and the up to the point comments.

I am grateful to Paula Rojas-Tirado for the assistance, the support, the positivity and the hospitality during the pilot-scale experiment. I would also like to thank Kamilla M.S. Kaarsholm and Ravi K. Chhetri for making this journey funnier and smoother, Adam Hambly, Per. B. Pedersen and Colin Stedmon for the nice discussions and the valuable comments.

Both OxyGuard International A/S and DTU Environment have provided an inspiring atmosphere and pleasant work place environment. Therefore, a big thank to all my colleagues for the positive energy and their effort to make me speak “kun Dansk”. I would like to thank Anne Harsting for keeping all practicalities under control and all the lab technicians (DTU Environment and DTU Aqua) for their help over the years. It was fantastic to have the opportunity to work with you.

Finally, I want to thank my friends, especially Varvara and Giannis for the happy moments and the patience during the stressful periods. A very special gratitude goes to my mom and dad, who always believed in me and never put limits to my dreams and wishes, to George and Panagiotis for being always there for me. Σας αγαπώ πολύ και ευχαριστώ για όλα!

I would have never made it without you.

To all of you,

Thank you! Mange tak! Ευχαριστώ!

December 2018

Aikaterini Spiliotopoulou

# Summary

The decline of wild fish stock and the increasing demand for food and fish protein have accelerated the development of fish farming. The intense fish production in limited space (e.g. sea cages) has potentially deteriorated the aquatic environments (nutrient accumulation from uneaten feed and excreta cause eutrophication, pollution, chemical compounds, disease outbreaks, escapes etc.) gaining the scientific and societal attention. The environmental impact of aquaculture in combination with the competition for land use (leisure activities, aesthetic impact, tourism, residential development etc.) and the desire for a profitable business have contributed to a shift to land-based aquaculture systems.

Recirculating aquaculture systems (RAS) are closed-containment systems where fish are farmed in reused water and provide a stable annual fish production. Due to the controlled farming environment, where water quality control systems and waste treatment technologies are installed, the fish quality and growth are improved while the risk of fish escapes and miscellaneous incidents are minimized. However, because of the recirculation (up to 99%) and the increased stocking density, waste derived from fish feed and fish excreta is accumulated. The control of organic matter in a RAS is of high importance for the good management of the facility. High organic matter loading in the water deteriorates the water quality, favouring the microbial blooming which might lead to disease outbreak directly affecting the fish. Additionally, increased levels of organic matter reduce the efficiency of the various water treatment processes.

Several technologies have been installed to remove waste, and consequently organic matter, from the water stream of a closed system. However, waste removal processes are not fully optimized and the interactions between the waste treatment units are not well understood. Ozone has been implemented in several water treatment applications as a secondary treatment step to improve the water quality by oxidizing the organic matter and miscellaneous dissolved compounds in the water, having also bactericidal properties ensuring simultaneously disinfection. However, ozone is also toxic for aquatic organisms in extremely low concentrations (0.01 mg O<sub>3</sub>/L). Therefore, the risk of losing fish because of overdosing inhibits the full implementation of ozone in aquaculture industry.

The aims of this PhD thesis were to design an ozonation system for RAS, based on the ozone demand of the specific system, where the water quality is improved without compromising the fish welfare, and then, to be able to monitor the ozone within the system with a novel, accurate and real-time measuring method relying on the fluorescence sensitivity towards ozone.

Aquatic dissolved organic matter has numerous fluorescent properties and it is highly reactive with ozone. Water samples were collected from several aquatic facilities around Denmark and then were analysed with fluorescence spectroscopy to determine the fluorescent character. RAS samples were subjected to ozonation to investigate the responsiveness towards ozone. Similar fluorescence components were present in all studied RASs, with different reactivity suggesting that a fluorescence based sensor could be used as an indirect ozone dosage determination tool in water, since the fluorescence intensities and dissolved organic matter degradation by ozone were well correlated. Furthermore, potential applications of such a sensor were proposed.

To design an optimal ozonation system, the water from the specific facility should be analysed in terms of ozone demand and ozone lifetime. Each facility is unique since the process water content of solutes, the operational conditions, and the water treatment units, the fish species and stocking density vary greatly, resulting in different water matrix. Therefore, the ozone reactions in this particular water should be investigated prior to installation, to ensure that the amount of ozone required to improve water quality is sufficient and it will be degraded long before it reaches the biofilters or the culture tanks.

Having experimentally determined the ozone demand and kinetics, the predicted ozone dosages were applied in pilot-scale RASs to verify the effect of ozone on water quality of continuous operated freshwater RASs. Several water parameters were investigated including non-volatile organic matter, chemical oxygen demand, biological oxygen demand, ammonia, nitrate and nitrite levels, particles number and size, and microbial activity. Fluorescence organic matter was analysed by fluorescence Excitation Emission Matrix (EEM) spectroscopy coupled with Parallel Factor analysis (PARAFAC) for a more accurate identification of the organic matter. The overall water quality was significantly improved upon ozonation, proportionally to ozone dosage applied, suggesting that the predicted ozone dosages matched with the needs of the water. During ozonation no fish mortality was observed.

The water matrix has huge influence in the design of an ozonation system. The determination of ozone in seawater samples is more complicated than in

freshwater. In seawater, where bromide is naturally present, bromo-oxides are formed in presence of ozone, which are toxic to fish. Thus, it is vital to be able to determine the critical point between the ozone dosage required to improve water quality and avoiding the formation of brominated by-products. Attempts to measure fast ozone in brominated water were made setting the basis for a modified analytical method. Further investigations are needed to increase the accuracy and to verify the breakpoint between optimal ozonation and brominated by-product formation inhibition in seawater RAS.

In conclusion, this PhD study elucidated that when ozone is properly implemented in a RAS, having taken into consideration the ozone demand and the lifetime of ozone for the system of interest, the water quality of a RAS will be remarkably improved. To determine the ozone demand and lifetime, fluorescence spectroscopy was used, since it was found to be a good indicator of organic matter accumulation in RAS and highly sensitive towards ozone treatment. The detailed analysis of the fluorescence dissolved organic matter contained in RAS water, revealed four independently varying fractions with different reactivity and responsiveness to ozone, suggesting that a fluorescence based sensor targeting a specific wavelength transition could be used to determine indirectly the ozone concentration in water.



# Dansk sammenfatning

Nedgangen i den vilde fiskebestand og den stigende efterspørgsel efter mad og fiskeprotein har ført til fiskeopdræt i det marine miljø. Den intense fiskeproduktion i snævre rum (fx havbure) har medført forringelse af vandmiljøet (næringsopbygning fra ufordøjet foder og udskillelse forårsaget af eutrofiering, forurening, kemiske forbindelser, sygdomsudbrud, undslip osv.), som har givet videnskabelig og offentlig opmærksomhed. Miljøpåvirkningen fra akvakultur i kombination med konkurrencen om arealanvendelse (fritidsaktiviteter, æstetisk påvirkning, turisme, boligudvikling mv.) og ønsket om rentabel virksomhed har bidraget til et skifte tilbage mod landbaserede akvakultursystemer.

Recirkulerende akvakultursystemer (RAS) giver en stabil fiskeproduktion. På grund af det kontrollerede produktionsmiljø, hvor vandkvalitetsstyringssystemer og affaldsbehandlingsteknologier er implementeret, kan fiskekvaliteten og væksten forøges, mens risikoen for fiskeundslip og diverse uheld minimeres. Men på grund af den høje recirkulationen (op til 99 %) og den øgede strømning akkumuleres affald fra fiskefoder og fiskesekretorer. Dermed bliver kontrollen af organisk stof i RAS af stor betydning for at sikre en god forvaltning af anlægget. Høj organisk stofbelastning i vandet forringer vandkvaliteten, hvilket favoriserer den mikrobielle blomstring, der kan føre til sygdomsudbrud. Derudover vil øgede niveauer af organisk materiale reducere effektiviteten af de forskellige vandbehandlingsteknologier.

Flere teknologier er blevet installeret for at fjerne partikler og organisk materiale fra vandet. Imidlertid er vandbehandlingsteknologierne ikke fuldt optimerede, og interaktionen mellem dem ikke forstået. Ozon er blevet implementeret i flere vandbehandlingssystemer så som spildevandsrensning, svømmebassiner mv., som et sekundært behandlingstrin for at forbedre vandkvaliteten. Derudover har ozon bakteriedræbende egenskaber, der sikrer desinfektion. Dog er ozon giftig for vandlevende organismer i ekstremt lave koncentrationer (0.01 mg O<sub>3</sub>/l). Frygt for at miste fisk fra overdosering af ozon hæmmer brugen af ozonbehandling i RAS.

Formålet med denne ph.d.-afhandling er at designe et ozonsystem til RAS baseret på ozonbehovet i det specifikke recirkulerede akvakultur system, hvor vandkvaliteten forbedres uden at kompromittere fiskens velfærd. Herudover har målet været, at kunne overvåge ozonkoncentrationen i systemet med en

ny, præcis, realtids målemetode baseret på fluorescens-følsomhed overfor ozon.

Det er velkendt, at vandopløst organisk stof har fluorescens egenskaber og er meget reaktivt med ozon. Vandprøver indsamlet fra flere anlæg omkring Danmark blev analyseret med fluorescerende spektroskopi for at bestemme RAS-vandets fluorescerende karakter og for at identificer ligheder i fluorescensbestanddelene i vandprøver fra de forskellige RAS. Prøverne blev derefter udsat for ozonering og efterfølgende analyse med fluorescensmetoden for at validere ozon-effekten. Det viste sig, at bestanddele med ensartede fluorescensaktiviteter var til stede i vandprøver fra alle involverede RAS, men med forskellig ozon-reaktivitet. Dette tyder på, at en fluorescens baseret sensor kan anvendes som et indirekte ozondoserings-bestemmelsesværktøj i vand, da fluorescensintensitet og det opløste organiske materiales nedbrydning ved ozonering var godt korreleret. Potentielle anvendelsesområder af en sådan ozon-måle-metode er også blevet vurderet.

For at designe et optimalt ozonsystem skal vandet fra det specifikke anlæg analyseres med hensyn til ozonforbrug og ozonlevetid. Hvert anlæg er unikt, da fiskeart, foderstrategi, tætheder/biomasse, vandbehandlingseffektivitet og andre driftsbetingelser varierer meget, og som resultat giver en vandmatrix der varierer – ikke blot fra anlæg til anlæg, men også over produktionscyklus på det aktuelle anlæg. Ozonreaktionerne i det specifikke vand bør undersøges inden installationen for at sikre, at mængden af ozon, der kræves for at forbedre vandkvaliteten, er tilstrækkelig og ozon vil blive nedbrudt længe før det når biofilterne eller kulturtankerne.

Efter at ozonforbrug og kinetik blev eksperimentelt bestemt, blev de forudbestemte ozondoser anvendt i pilotskala-RAS for at verificere effekten af ozondoser på vandkvaliteten af kontinuert anvendte ferskvands-RAS. Flere vandparametre blev undersøgt, herunder fluorescensorganisk stof, ikke-flygtigt organisk materiale, kemisk iltforbrug, biologisk iltbehov, ammoniak, nitrat og nitritniveauer, partikelantal og -størrelse og mikrobiel vandkvalitet. Den samlede vandkvalitet blev signifikant forbedret ved ozonering, proportional med den anvendte ozondosering. Under ozonprøverne blev der ikke observeret fiskedødelighed.

Vandmatrixen har stor indflydelse på udformningen af et ozonsystem. I havvand, hvor bromid er naturligt til stede, dannes bromoxider, der er giftige for fisk, i tilstedeværelse af ozon. Bestemmelsen af ozon i havvandsprøver er mere kompliceret end i ferskvand. Forsøg på at måle hurtig ozon i bromeret

vand blev lavet som grundlag for en modificeret analysemetode. Yderligere undersøgelser er nødvendige for at øge nøjagtigheden og for at verificere det kritiske punkt mellem ozon- doseringen, der er nødvendig for at forbedre vandkvaliteten og undgå dannelsen af bromerede biprodukter i havvands-RAS.

Afslutningsvis konkluderer denne ph.d.-afhandling, at når ozon er korrekt implementeret i RAS, da vil vandkvaliteten blive bemærkelsesværdigt forbedret, når der tages hensyn til ozonforbruget og ozons levetid for det pågældende system. Til bestemmelse af ozonbrug og ozons levetid blev fluorescensspektroskopi anvendt og det viste sig at være en god indikator for akkumulering af organisk stof i RAS og meget følsom over for ozonbehandling. Den detaljerede analyse af det opløste organiske stof i fluorescens optaget i RAS-vand afslørede fire uafhængigt varierende fraktioner med forskellig reaktivitet og reaktion over for ozon, hvilket tyder på, at en fluorescensbaseret sensor rettet mod en specifik bølgelængdeovergang kunne anvendes til at bestemme indirekte ozonkoncentrationen i vand.





# Table of contents

<b>Preface</b> .....	<b>iii</b>
<b>Acknowledgements</b> .....	<b>vii</b>
<b>Summary</b> .....	<b>viii</b>
<b>Dansk sammenfatning</b> .....	<b>xii</b>
<b>Table of contents</b> .....	<b>xvi</b>
<b>List of abbreviations</b> .....	<b>xviii</b>
<b>1 Introduction</b> .....	<b>1</b>
1.1 Background .....	1
1.2 Research objectives .....	2
<b>2 Recirculating aquaculture systems</b> .....	<b>3</b>
2.1 Challenges in RAS.....	4
2.2 Current disinfection methods in RAS .....	5
2.3 Ozone .....	6
2.3.1 Ozonation challenges in RAS .....	7
2.3.2 Ozone determination in water.....	8
<b>3 Fluorescence spectroscopy</b> .....	<b>9</b>
3.1 Determination of dissolved organic matter .....	10
3.2 Sensitivity of fluorophores to ozone .....	11
3.3 Characterisation of fluorescent dissolved organic matter .....	13
3.4 Responsiveness of FDOM to ozone .....	14
3.5 Applications of fluorescence measurement in ozonated RAS systems .....	17
3.5.1 Determination of delivered ozone dosage .....	17
3.5.2 Online control in recirculation systems .....	19
3.5.3 Online control in flow through systems .....	19
<b>4 Safe design of ozonation installations</b> .....	<b>21</b>
4.1 Optimal ozone dosage for pilot RAS.....	22
4.1.1 Ozone kinetics and organic matter.....	22
4.1.2 Ozone demand.....	23
<b>5 Ozonation of freshwater pilot-RAS</b> .....	<b>25</b>
5.1 Ozonation of pilot-RAS .....	25
5.2 Ozone effect on water quality .....	26
5.2.1 Ozone effect on water transparency.....	27
5.2.2 Ozone effect on Oxidation - Reduction potential (REDOX) .....	27
5.2.3 Ozone effect on organic matter.....	28
5.2.4 Ozone effect on fluorescent organic matter .....	29

5.2.5	FDOM component selectivity.....	30
5.2.6	Component removal rates .....	31
5.2.7	Ozone effect on particles .....	32
5.2.8	Ozone effect on nitrogen-based compounds .....	33
5.3	Ozone effect on microbial water quality .....	34
5.3.1	Bacterial activity .....	34
5.3.2	Bacterial abundance .....	36
<b>6</b>	<b>Ozonation of marine RAS.....</b>	<b>37</b>
6.1	Analytical methods .....	38
6.1.1	Ozone in seawater .....	38
6.1.2	Optimization of analytical method .....	39
6.1.3	HOBr, Br <sup>-</sup> and BrO <sub>3</sub> <sup>-</sup> in seawater .....	41
<b>7</b>	<b>Conclusions.....</b>	<b>43</b>
<b>8</b>	<b>Perspectives .....</b>	<b>45</b>
8.1	Significance of the work .....	45
8.2	Suggestions for future research .....	45
	<b>References.....</b>	<b>46</b>
	<b>Papers.....</b>	<b>57</b>

# List of abbreviations

The abbreviations found bellow were used in the thesis. When they are firstly introduced in the text they will be presented by the full name followed by abbreviation in brackets and then they will be referred to by the abbreviation.

Abbreviations	Full name
BOD <sub>5</sub> TOT	Biological Oxygen Demand - Total
BOD <sub>5</sub> DIS	Biological Oxygen Demand - Dissolved
BOD <sub>5</sub> PAR	Biological Oxygen Demand - Particulate
COD <sub>TOT</sub>	Chemical Oxygen Demand - Total
COD <sub>DIS</sub>	Chemical Oxygen Demand - Dissolved
COD <sub>PAR</sub>	Chemical Oxygen Demand - Particulate
DOC	Dissolved organic carbon
DOM	Dissolved organic matter
EEM	Fluorescence excitation-emission matrix spectroscopy
FDOM	Fluorescent dissolved organic matter
HP	Hydrogen peroxide
NVOC	Non-volatile organic carbon
OM	Organic matter
PARAFAC	Parallel factor analysis
RAS	Recirculating aquaculture system
TAN	Total ammonium nitrogen
UVA	Ultraviolet absorption
UV-A	Ultraviolet-A (340-400nm)
UVT	Ultraviolet transmittance

# 1 Introduction

## 1.1 Background

The decline in stocks of commercially caught fish, in combination with the increasing need for fish protein due to continuing population growth have led to the rapid development of aquaculture industry, worldwide. According to Food and Agriculture Organization of the United Nations 50% of all fish are produced in aquaculture systems (FAO, 2016). The past 8 years the fish production in Europe has increased by 23% (FEAP Production Report, 2017) and it is expected to continue growing at a rate higher than most other industries for the anticipated future.

The water use and discharge is of great importance since the environmental impacts of the aquaculture industry have increased and consequently raised the scientific and societal concern. Land-based recirculating aquaculture systems (RAS) are closed-containment systems where fish are farmed in reused water (Lekang, 2007). RAS has become increasingly important as the available water is better utilized, achieving production continuity. However, the reused water, the high production intensity and feed loading (Colt et al., 2006; Pedersen et al., 2012) lead to accumulation of waste products in the water (Martins et al., 2010; Verdegem, 2013). Although fish can grow in water of sub-optimal quality, their performance will be affected. Thus, these intense closed systems require good water quality to support growth and minimise disease outbreaks.

To achieve good water quality, several processes are needed. Aeration, pH, salinity and temperature adjustment, particle removal, control of ammonia and nitrite (Piedrahita, 2003; Martins et al., 2010) are normally used to create optimal conditions, while disinfection is also needed to reduce the burden of microorganisms. Disinfection in RAS relies on oxidative agents or other types of disinfection like Ultraviolet (UV) irradiation and ozone. Nonetheless, chemical residuals might affect the cultivated species, the facility and the nearby environment (Wooster et al., 2005; Pedersen et al., 2010) and UV installations are expensive.

Ozone has been widely implemented as a supplementary water treatment technology in other industries (Von Gunten, 2003; Hansen et al., 2010; Hansen et al., 2016; Hansen, et al., 2016) having undeniable benefits towards water quality. Although ozonation has been applied for years in aquaculture (Owsley, 1991; Summerfelt et al., 1997; Good et al., 2011), there is lack of

knowledge regarding the reaction kinetics, the control of the dosage and side effects of excessive ozonation. The risk of losing fish or damaging the biofilters leads to a reluctance of the aquaculture managers to integrate ozone in RAS.

The design of a complete and reliable ozone system for the water treatment of semi-closed aquatic systems would improve the water quality. The project aimed to address the hypotheses:

- Fluorescence technique is an alternative to indigo (colorimetric) assay in terms of ozone dosage determination in the aquatic phase.
- The proper ozonation design of a RAS can be made by analysing water samples in the laboratory and thus predicting the ozone demand for the specific system.
- Ozone dosage requirements vary significantly depending on the water matrix characteristics potentially leading to undesirable side effects for cultured species.
- Proper and controlled ozone injection can reduce the formation of bromine by-product in seawater RAS.

## 1.2 Research objectives

The overall objective of the PhD project was to contribute to the knowledge that is needed to design optimal ozonation systems for aquaculture and the ability to monitor ozone. Thus, the specific objectives of the PhD thesis were:

- To design a continuous ozonated RAS by improving the water quality without compromising the fish welfare (**Paper II**) by
  - using fluorescence spectroscopy to continuously measure and control ozone in aqueous solution (**Paper I**)
  - investigating the ozone kinetics and lifetime and utilising them to predict the ozone requirements of a RAS (**Paper II**)
- To determine which water quality parameters were improved due to ozonation and the potential side effects in
  - freshwater (**Papers II, III, IV**) and
  - marine RAS water

## 2 Recirculating aquaculture systems

Recirculating aquaculture systems (RAS) are land-based systems where fish are farmed in reused water (Figure 1). The circulation of the water and the internal water treatment make the RAS distinct from traditional flow-through systems and the amount of water used per kg fish produced is significantly reduced.

The water treatment system in a conventional RAS may include physical, chemical and biological processes to maintain the water quality in acceptable levels. More specific, the removal of large particles, which is essential for the RAS (Cripps and Bergheim, 2000), is achieved by drum filters, sedimentation tanks, swirl separators, sand filters etc. (Nam et al., 2000; Timmons et al., 2002) depending on the size of the particles. Fine particles are accumulated over time within the system (Chen et al., 1993; Fernandes et al., 2014; 2015) and can be removed by upcoming processes e.g. membrane filtration technology and foam fractionators (protein skimmers). The dissolved organic matter can be removed in the biofilters. The commonly used biofilters in RAS are fixed bed and moving bed filters. Aeration and degassing units (e.g. trickling filters) are also integrated in the system, while temperature and pH are continually adjusted to provide optimal growth conditions. To control or eliminate pathogens and to further improve the water quality, disinfection is also needed (Gonçalves and Gagnon, 2011; Pedersen and Pedersen, 2012) which is achieved by ozonation, UV irradiation or use of chemotherapeutants.

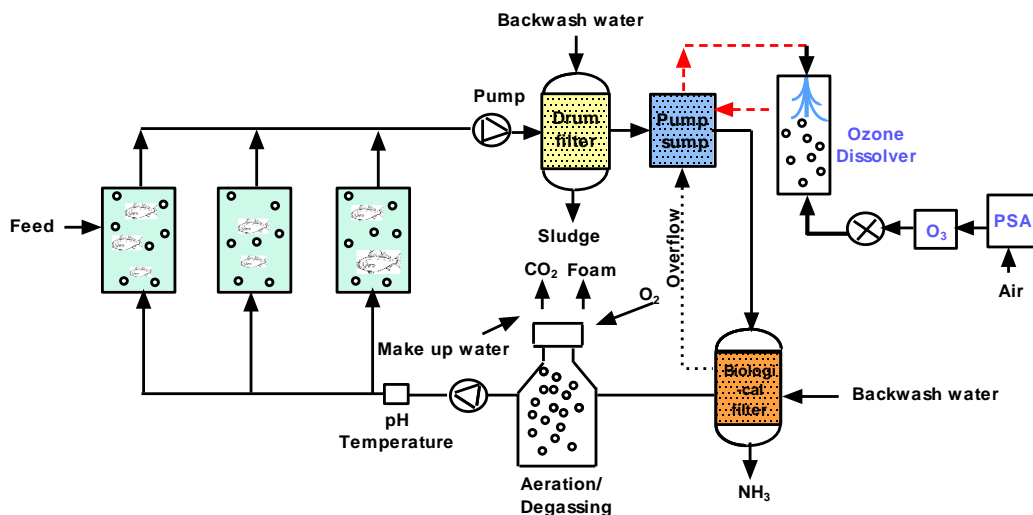
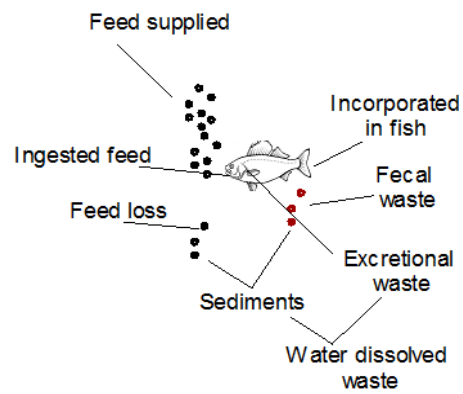

**Figure 1:** Schematic representation of a recirculating aquaculture system.

## 2.1 Challenges in RAS

Although RAS is considered as the most promising solution and an environmental friendly technology, the recirculation technology can also cause problems for RAS operation and water quality. The prolonged hydraulic retention times in combination with the low-water exchange and the high feed loading (Blancheton et al., 2013; Rurangwa & Verdegem, 2015) entail accumulation of organic and inorganic compounds (Bullock et al., 1997; Davidson et al., 2011), where slow/non-degradable dissolved organic matter (DOM), micro-particles and heavy metals are the most pronounced (Davidson et al., 2009). These compounds mainly come from the uneaten fish feed and the subsequent dissolved and particulate fish excreta (Figure 2; Dalsgaard and Pedersen, 2011) or are produced by the various water treatment technologies.

The physicochemical properties of waste are highly related to feed composition and affect directly the organic matter (OM) and the nitrogen and phosphorous output (Dalsgaard and Pedersen, 2011; Nijhof, 1994; Timmons et al., 2002). Good management keeps the uneaten feed at low levels (Reid et al., 2009; Bureau and Hua, 2010) while the daily produced fish waste should be removed from the stream and treated (Cripps, 1995).



**Figure 2:** Faecal and soluble waste in a system produced by fish.

The accumulated OM or elevated chemical oxygen demand (COD; Fu et al., 2015) in RAS favour bacteria, protozoa and micro-metazoa blooming, affecting fish and system performance (Bullock et al., 1997). These microorganisms can be found in several locations within the system e.g. in biofilters, in the water column and on other surfaces while they are able to metabolize OM, ammonia, nitrite, and nitrate (Blancheton & Canaguier, 1995; Bullock et al., 1997; Hagopian & Riley, 1998; Blancheton, 2000; Leonard et al., 2000; Nam et al., 2000). Although some niches are vital for the system e.g. bacteria that convert ammonia to nitrite (e.g. *Nitrosomonas*, *Nitrosospira*) and bacteria that convert nitrite (toxic to fish) to nitrate (e.g. *Nitrosospira*), there are potential pathogens with fast life-cycles that might adversely affect the cultured species (Bullock et al., 1997).



Besides being a good substrate for bacterial growth, OM might give pathogens a transport potential within the plant (Summerfelt, 2003) allowing the disease to propagate. Additionally OM might inhibit the disinfection efficiency which aims to maintain the micro-organisms in low levels. More specifically, in case of UV treatment, OM absorbs the UV radiation and shields microbes from the treatment. During ozonation, the OM is readily oxidized by ozone, since it is easily degradable, leaving low residual ozone concentration in the water, which might not be sufficient to ensure disinfection. Thus, the successful management of a RAS relies, among others, on the control of DOM (Hambly et al., 2015) while the disinfection is highly required to ensure fish welfare and increased production.

## 2.2 Current disinfection methods in RAS

Disinfection has been applied as part of the management of RAS to control or eliminate pathogens (Pedersen and Pedersen, 2012) improving simultaneously the water quality (Gonçalves and Gagnon, 2011). Disinfection can occur at different points within the system. The inlet water can be exposed to UV irradiation preventing the entrance of potential pathogens from external water source in the system (Timmons et al., 2002). However, the high cost and the risk of fouling inhibit the UV installation in RAS.

Chemotherapeutants can be applied in the rearing tanks to treat the cultured species directly, controlling microbial profusions and preventing disease outbreaks e.g. formalin, hydrogen peroxide and peracetic acid (Noble & Summerfelt, 1996; Pedersen et al., 2010; Pedersen & Pedersen, 2012; Attramadal et al., 2012; Pedersen et al., 2013; Verner-Jeffreys, 2015). If chemotherapeutants are not administered properly, fish will experience increased physiological stress. High concentrations of chemotherapeutants might impair biofilter performance, kill the synergetic microorganisms along with the pathogens, be present at too high concentrations in the culture tank affecting the fish (Noble & Summerfelt, 1996; Schwartz et al., 2000), jeopardise employee safety and set the ecosystem at risk when non-degraded residuals are released into nearby aquatic recipients (Hohreiter & Rigg, 2001; Masters, 2004; Wooster et al., 2005; Pedersen et al., 2010). In November 2008, the Danish Association of Danish Aquaculture had announced that the use of formalin is expected to be phased out within 5 years.

To address the need for environmentally friendly disinfectants, drifting away from chemotherapeutants, ozone has been introduced as an alternative in

RAS, which can be applied within the recirculation loop, prior to biofilters. The biofilters will function as buffer; the bacteria in the biofilters will have time to adjust to potential residual concentrations (Bullock et al., 1997; Summerfelt and Hochheimer, 1997; Tango & Gagnon, 2003; Sharrer and Summerfelt, 2007; Summerfelt et al., 2009; Davidson et al., 2011; Attramadal et al., 2012; Powell et al., 2015; **Paper I**; **Paper II**) ensuring that no ozone would reach the culture tanks.

## 2.3 Ozone

Ozonation is a well-established technology with indisputable benefits for water quality (Powell and Scolding, 2016). Ozone is a strong oxidizing agent, reacting rapidly and in low concentrations, first with the easily degradable DOM (Eq.1) and inorganic pollutants, and then with the decreasingly reductive pollutants (von Sonntag and von Gunten, 2012). If more ozone is dosed than the immediate demand, ozone will be decomposed to hydroxyl radicals (Eq. 2), which are non-selective and highly reactive species. This reaction is pH dependent. Hydroxyl radicals are able to oxidize a range of recalcitrant pollutants (Eq. 3) (von Sonntag and von Gunten, 2012).

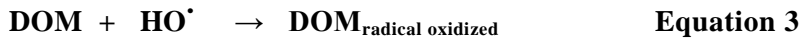
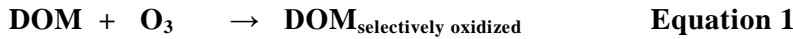

Ozone enhances water quality by oxidising natural organic matter (NOM) leading to reduced COD, while it removes colour and suspended solids (Summerfelt & Hochheimer, 1997; Summerfelt et al., 2009; Davidson et al., 2011; **Paper II**). Moreover, it accelerates protein degradation and improves coagulation and filtration processes (Antoniou and Andersen, 2012). In presence of ozone, the oxidation-reduction reaction (REDOX) level is increased, stabilizing the oxygen concentration in the water. It contributes to odorant reduction (geosmin and 2-methylisoborneol (MIB)), improving the taste of fish (Gonçalves and Gagnon, 2011).

When ozone acts as disinfectant, a specific dissolved ozone concentration for a given contact time is required, which might be higher than the concentration required to improve water quality (Bullock et al., 1997; Summerfelt et al., 1997). Ozone inhibits infectious viruses (Owsley, 1991), bacteria (Colberg & Lingg, 1978; Liltved et al., 1995; Tango & Gagnon, 2003; Summerfelt et al., 2009) and protozoan (Tipping, 1988) in several aquaculture

systems resulting in improved growth (Good et al., 2011). Therefore, ozone appears to improve remarkably the water quality in RAS.

Despite ozone significantly enhances the water quality in RAS (Bullock et al., 1997; Summerfelt & Hochheimer, 1997; Powell et al., 2015; **Paper I; Paper II; Paper III; Paper IV**), it should be ensured that ozone residuals will never reach the fish and therefore, ozone residual exiting the ozone reaction tank must be removed or completely consumed prior to culture tank.

### 2.3.1 Ozonation challenges in RAS

In a non-meticulously designed system, residual ozone (due to overdose) may reach the culture tanks causing significant harm to cultured species (Bullock et al., 1997; Davidson et al., 2011). Ozone is toxic to a wide range of marine and freshwater organisms at very low residual concentrations (0.01 mg/L - 0.1 mg/L; Gonçalves & Gagnon, 2011) by oxidizing the gills and the tissues of fish and eventually leading to death. The risk of losing fish and the high investment and running costs are limiting parameters and lead to a reluctance by the aquaculture industry to use ozone. Therefore, ideally, ozone should be correctly delivered and controlled to ensure that it is fully degraded before the treated water returns to the culture tanks.

Depending on the water matrix, additional issues emerge. In freshwater RAS, ozone reacts with humic substances, producing several detrimental by-products (Summerfelt and Hochheimer, 1997; Summerfelt, 2003), mainly a mix of aldehydes, ketones, carboxylic acids, and esters, which are potentially toxic (Matsuda et al., 1992; von Gunten, 2003; Hammes et al., 2006). These compounds are typically removed during a subsequent biological treatment step (Hammes et al., 2006). Seawater naturally contains bromide ions (Heeb et al., 2014). During ozonation of seawater, bromo-oxides are formed (Antoniou and Andersen, 2012; Heeb et al., 2014) with long lifetime in the water. These newly formed compounds are toxic to fish, bivalves and crustaceans.

A well-designed ozone system, taking into account the amount of ozone that each facility (cultured species, life stage and hydraulics) requires and the daily variation in ozone demand has not been yet proposed. Additionally, the amount of ozone added in the water as well as its residual concentration should be also determined accurately and in real time in order to prevent in-

cidents with detrimental consequences for the cultivated species and the facility in general, with enormous economic impact.

### 2.3.2 Ozone determination in water

If ozone is not correctly applied nor analytically verified, under-dosing or overdosing might occur with detrimental effects the RAS. A widely used method to determine the actual ozone concentration in water is by test kits (e.g DPD). Other colourimetric methods using chemical reagents (e.g. indigo method; Bader and Hoigné, 1981) require skilled operators working under laboratory conditions, which is difficult under commercial RAS operation. In this method, ozone decolorizes the indigo solution, and the level of decolorization is measured by a spectrophotometer at 600 nm.

The delivered/nominal ozone concentration in gas can be determined by the absorbance at 254 nm which has provided immediate and real time measurement of ozone dosage in WWTP effluent (Bahr et al., 2007; Gerrity et al., 2012). Hansen et al. (2010) found an equally good correlation at 272 nm. Another issue with absorbance spectroscopy is that it is not possible to identify the components contained in the OM in a water sample and its sensitivity to detect ozone in low concentrations is limited.

Oxidation reduction potential (ORP) probes measure the ratio of the oxidising and reducing species in the water. Essentially, the higher the ORP, the more oxidising agents are present in the water. Nonetheless, ORP sensors are not specific, and they cannot distinguish which dissolved oxidants increase REDOX potential, for example, ozone from chlorine. Furthermore, they do not have a stable relationship with the actual concentration of oxidants in water (Tango and Gagnon, 2003), without providing a stable ORP baseline. In the presence of free ozone, ORP sensors tend to fail becoming unable to measure ozone (Bullock et al., 1997) since their surface is oxidised by ozone forming platinum oxide.

Dissolved ozone can also be determined indirectly by measuring the formation of ozonated by-products (OBP) in marine water, which is also a complicated method due to water chemistry (Tango and Gagnon, 2003). A method to determine the amount of ozone delivered into water is missing. Thus, there is a need for a fast and sensitive method, reagent free, to determine online and in real-time the changes of OM in a RAS.

### 3 Fluorescence spectroscopy

DOM consists of a mixture of molecules able to absorb light energy (chromophores) and molecules that re-emit the absorbed light (fluorophores). Fluorescence is the release of energy, in the form of light, when molecules, namely fluorophores, are excited with a high energy light source. Humic substances and amino acids contained in proteins and peptides and their sub-categories are the most extensively studied fluorophores in aquatic environments (Coble, 1996; Hudson et al., 2007).

Although both absorption and fluorescence spectroscopy can provide insight into the nature of DOM, such as changes in chemical character or an indication of DOM source, fluorescence spectroscopy is a more selective and sensitive technique and has become a well-established analytical tool (Coble et al., 2014) in several water treatment applications. It is an inexpensive and straight forward measurement, able to optimise processes (Reynolds and Ahmad, 1997) and to identify deteriorating agents (Hudson et al., 2007). Fluorescence determines fast and accurately DOM in wastewater effluent (Hudson et al., 2007; Henderson et al., 2009; Carstea et al., 2016), drinking water (Cumberland et al., 2012), fresh water (Baker, 2001; Downing et al., 2009), seawater (Coble, 1996; Chen, 1999; Conmy et al., 2004; Baker & Spencer, 2004) and RAS (Hambly et al., 2015; **Paper I; Paper II; Paper III**). Additionally, it correlates with total organic carbon (TOC) (Carstea et al., 2016), biological oxygen demand (BOD) (Hudson et al., 2008), phosphate, nitrogen-based compounds (Baker and Inverarity, 2004) and microbial abundances (Cumberland et al., 2012). Excitation-emission matrices (EEMs) along with parallel factor analysis (PARAFAC) (Bro, 1997; Stedmon et al., 2003) can accurately identify the fluorescent components in a water sample. These underlying fractions can be cross-referenced across natural and engineered aquatic systems.

There are few studies that have investigated the decomposition behaviour of different fluorescent components in various ozonated systems using the coupled EEM-PARAFAC methodology (Liu et al., 2016; Chen et al., 2017; Mangalgi et al., 2017; Peleato et al., 2017). In case of RAS, EEMs and PARAFAC have been used to monitor changes in water quality (Hambly et al., 2015), as well as to control the operation of individual water treatment systems and avoid pathogen outbreaks (Henderson et al., 2009; Carstea et al., 2010; Murphy et al., 2011; Stedmon et al., 2011). However, no attempt has

yet been made to investigate the FDOM change in continuous ozonated RAS water utilising the EEM-PARAFAC technique.

### 3.1 Determination of dissolved organic matter

Currently the monitoring of DOM in RAS is achieved by analytical methods such as COD and BOD<sub>5</sub> (Hambly et al., 2015; Rojas-Tirado et al., 2017). BOD<sub>5</sub> is a slow analysis and it cannot be carried out within a timeframe which allows operators to react before fish health is compromised. Although COD analysis can be conducted in 1-2 h, it is not able to distinguish inert from bioavailable OM and they are quite expensive. Thus, an online detection and subsequent treatment control of DOM in the system would be of great importance for the efficient and low-risk operation of RAS (**Paper I; Paper II; Paper III**).

Water samples from different facilities in Denmark were analysed to verify if RAS water has similar fluorescence DOM (FDOM) character, independently on the cultivated species and stock densities, water treatment technologies employed and purpose (**Paper I**). Dissolved organic carbon differed between the facilities (from <0.05 to 20.3 mg DOC/L), due to systems' variability. The water samples were initially analysed using fluorescence wavelength transitions previously used in a wastewater study (Hudson et al., 2007). The components would be addressed by their emission spectra peaks, i.e. C<sub>340</sub>.

In the presence of high OM, the fluorescence intensities in non-ozonated RAS samples were elevated (**Paper I; Paper II**). Water samples derived from RASs with high stocking densities consisted mainly of humic-like fluorophores (C<sub>450</sub>; Figures 3a, 4), which were also present in municipal wastewater and are highly correlated with TOC (Carstea et al., 2010). On the contrary, the protein-like fluorophores were less pronounced, yet present (C<sub>340</sub> and C<sub>310</sub>; Figure 3a, 4). FDOM in aquaria (with low OM content) was detected in significantly lower intensities making it difficult to conclude which peak dominated (Figure 3b).

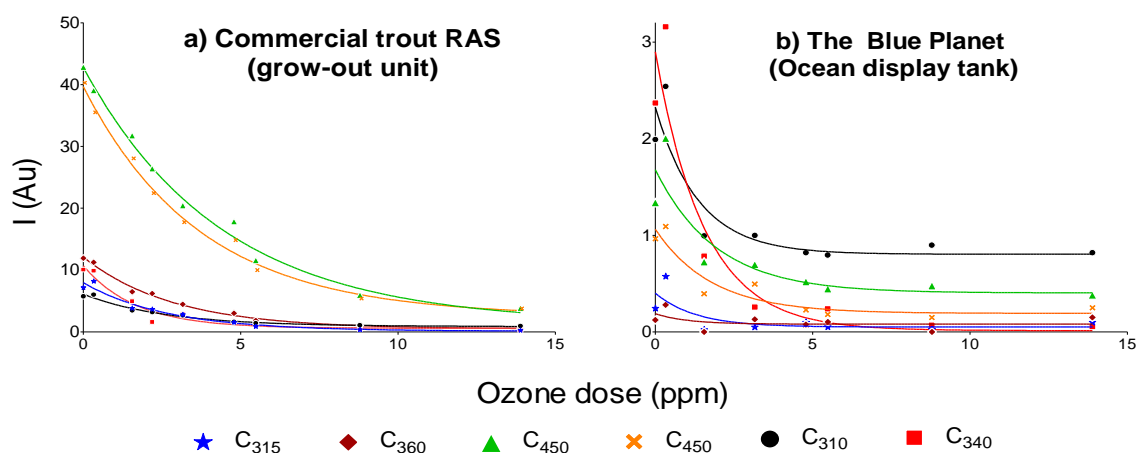

**Figure 3:** The effect of different ozone dosages on the fluorescence intensity (I; expressed in arbitrary units (AU)) in water from two selected aquaculture systems with different organic matter content. Modified from **Paper I**.

Thus, it is clear that FDOM exists in RAS water (Hambly et al., 2015; **Paper I; Paper II; Paper III**) independently on the operational conditions. The fluorescence components were distinct in the predetermined wavelengths but a more detailed identification of the OM character is required.

### 3.2 Sensitivity of fluorophores to ozone

Fluorophores are more reactive than DOC and consequently easier to be oxidised by ozone (Liu et al., 2015). Therefore, the fluorescence intensity is affected (Korshin et al., 1999), suggesting that spectra-based methods are suitable for online monitoring, due to a high sensitivity and ease of use (Hudson et al., 2007; Li et al., 2016). The high reactivity of aquatic DOM with ozone has raised questions related to the ability of fluorescence to measure indirectly the delivery of ozone into water.

Water samples from different RASs were subjected to ozonation (bench scale) to provide a representative and comprehensive investigation of the correlation between fluorescence indices and the degradation of DOM (Figure 3; **Paper I**). Low ozone dosages (<5 mg O<sub>3</sub>/ L) entirely removed the protein-like fluorophores, which were already in low intensities, and up to 50% the humic-like fluorophores (Figure 3; Figure 4). It has been reported that humic-like fluorophores, when subjected to ozonation, were unaffected, while a decrease in protein-like fluorophores was expected (Henderson et al., 2009). High ozone dosages (15 mg O<sub>3</sub>/ L or more) significantly reduced the fluorescence intensity, from 60% to 97.7% (Figure 3), without being able to oxidise

some fluorophores entirely suggesting that a low fluorescence activity remained in water, which did not react with ozone.

To verify if fluorescence increases proportionally with the OM accumulation within a RAS, water samples were collected from a pilot-RAS where trout were farmed. The sampling occurred over time, when the tanks were filled in only with clean water, a week after the fish had entered the system and when the system had reached steady state, in terms of biofilters performance. Fluorescence intensity was gradually increased from 20 to 60 Au (0 mg O<sub>3</sub>/L), suggesting that fluorescence is a good indicator of OM accumulation in the system (Figure 4; **Paper II**).

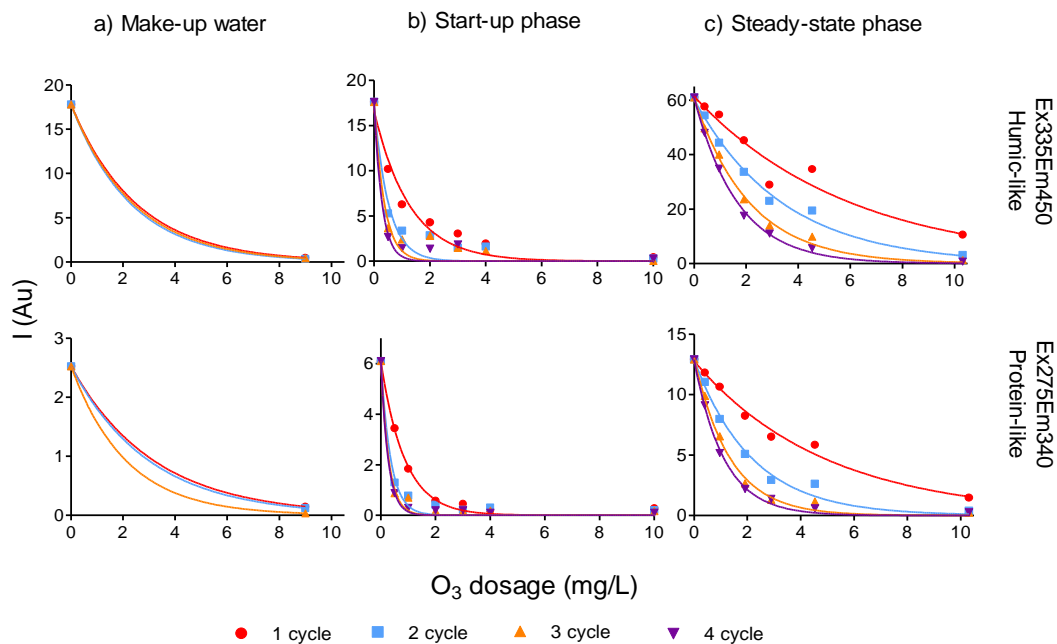

**Figure 4:** Fluorescence degradation of humic- and protein-like fluorophores (I; expressed in arbitrary units (AU)) in ozonated RAS water exposed to different ozone levels over time: a) make-up water, b) start-up phase and c) steady-state phase. Modified from **Paper II**.

To visualise the effect of different ozone dosages in RAS water, samples from a pilot-RAS were analysed with EEM spectroscopy (emission wavelength range: 146-692 nm; excitation wavelength range: 240-600 nm; Figure 5). The samples were analysed before, and throughout 8 days of continuous ozone treatments.



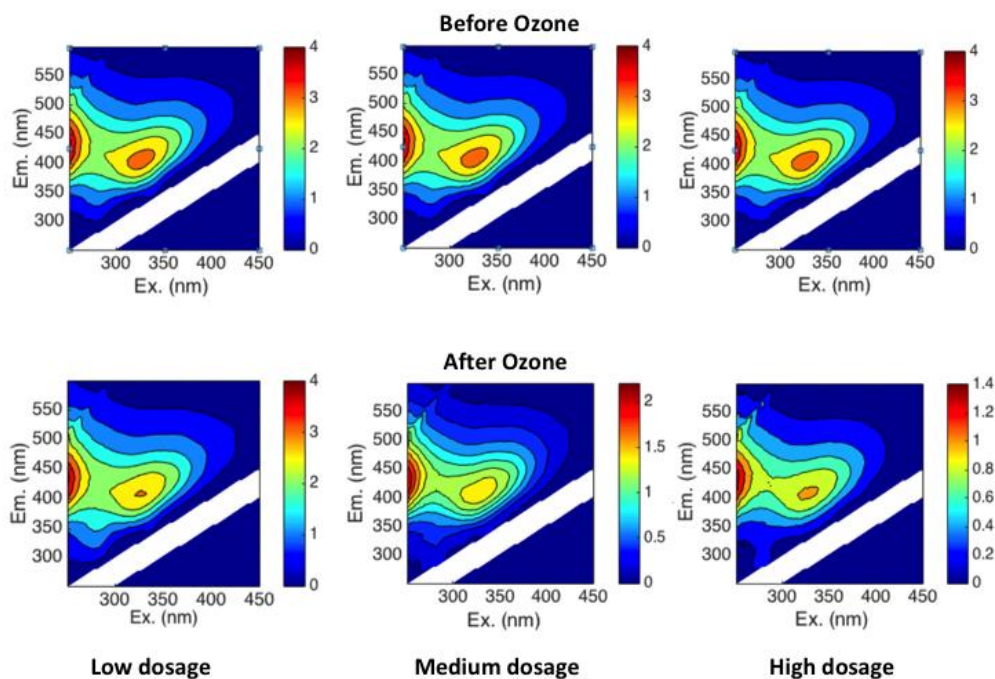

**Figure 5:** Typical EEMs of RAS water before ozone addition (top) and after 8-days of ozone treatment (bottom) where 3 different ozone dosages levels were applied. Note differences in scales, from **Paper III**.

Although the overall character of the EEMs appeared to remain similar (**Paper III**), the FDOM intensity from the non-ozonated system (Figure 5; top row) was significantly higher than the ozone treated systems (Figure 5; bottom row). More detailed approaches will allow identifying the different fluorescent fractions contained within the RAS water.

### 3.3 Characterisation of fluorescent dissolved organic matter

The EEM datasets were mathematically decomposed with PARAFAC technique and four independently varying fractions (Figure 6) were revealed in non-ozonated RAS water. Three components had their emission peak in the visible region ( $>380$  nm), whereas the last component had an emission peak in the UVA region (300-380 nm) with maximum intensity at 340 nm (**Paper III**). The OpenChrom database was used to cross-reference these fluorescent components with components obtained in previous studies (Murphy et al., 2014) to obtain more accurate identification of the fluorescent properties of each individual fraction. This comparison revealed that similar fluorophores were present in samples from natural, marine and freshwater systems

(Stedmon et al., 2007; Jørgensen et al., 2011; Gueguen et al., 2014; Murphy et al., 2014; Yu et al., 2015; Lambert et al., 2016) saline lakes (Osburn et al., 2011) and in wastewater (Yu et al., 2015).

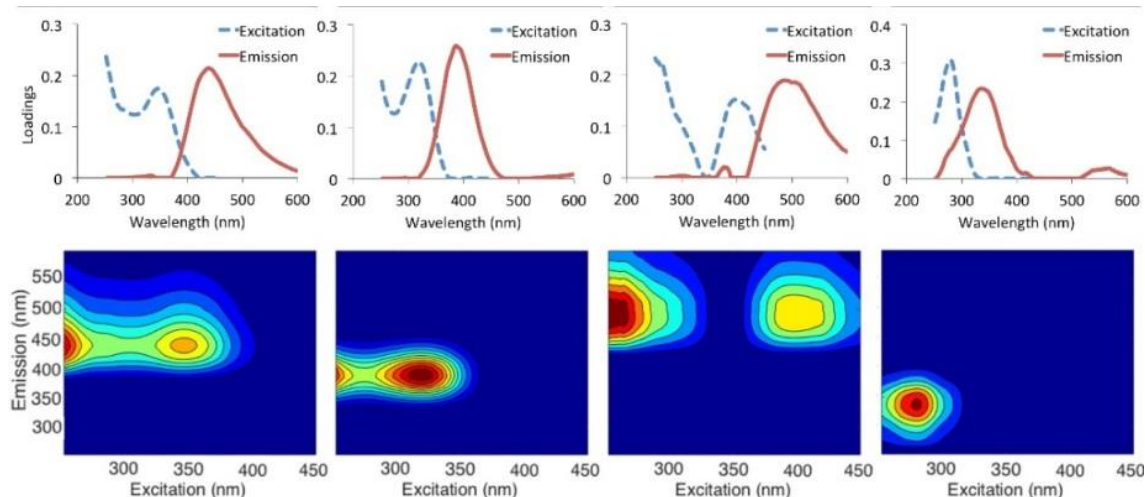

**Figure 6:** Loadings (top; stippled line stands for excitation wavelength while full line stands for emission wavelength) and contour plots of individual fluorescent components derived from the 4-component PARAFAC model (bottom; generated from 249 samples from all three ozonation levels and controls) from **Paper III**.

The  $C_{340}$  was present in streams, rivers (Yamashita et al., 2010; Cawley et al., 2012), oceans (Stedmon et al., 2011; Cawley et al., 2012), storm water, urban ponds (Williams et al., 2016) and in aquaculture (Nimptsch et al., 2015; Hambly et al., 2015; Yamin et al., 2017; **Paper III**). The components identified in the pilot-RAS water originated from the fish feed ( $C_{340}$ ), the make-up water ( $C_{439}$ ) and OM produced by fish and water treatment processes ( $C_{385}$  and  $C_{490}$ ; Hambly et al., 2015).

### 3.4 Responsiveness of FDOM to ozone

The water quality in a RAS with ozonation will eventually reach a new steady state (**Paper II**). Low ozone concentrations were found to reduce the fluorescence intensity in RAS samples in batch experiments (Figure 3; Figure 4). Since RAS water would be continually treated, it was hypothesized that low ozone dosages would be sufficient to maintain a relatively good water quality in pilot and full-scale RASs (**Paper II**).

A calibration curve is needed to ensure repeatability and reliability of measurements made by a fluorescence-based sensor which aims to control ozone dosage. The calibration curve should take into account the nature of fluores-

cence responsiveness to ozone. The curve and the range are crucial components to define the calibration properties. A significant linear regression with high  $R^2$  for humic- and protein-like fluorescent OM was found (Figure 7), indicating strong correlation and high accuracy. The slopes suggested that the humic-like FDOM (Figure 7a) was more vulnerable and sensitive to ozone than the protein-like FDOM (Figure 7b). However, when comparing these slopes across different RASs, great variations were observed (**Paper I**).

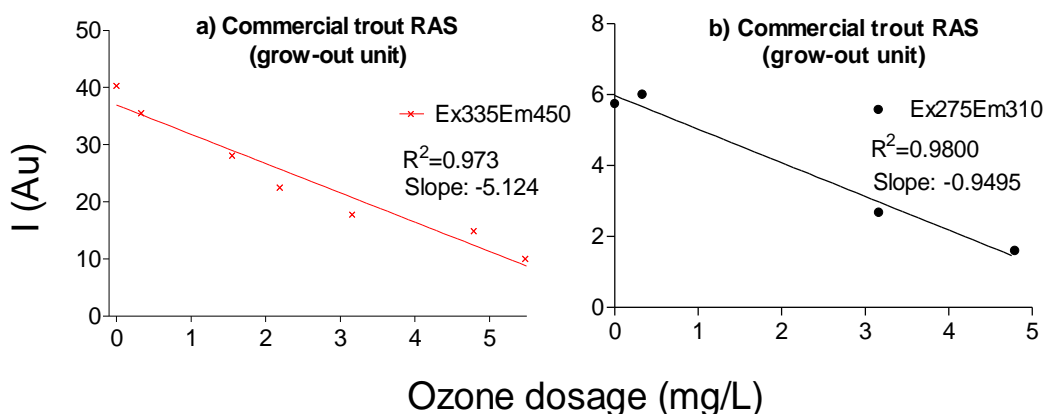

**Figure 7:** Calibration curves for a) humic b) and protein-like fluorophores. Modified from **Paper I**.

Previous studies have shown that UV absorbance at 254 ( $UV_{254}$ ; Bahr et al., 2007; Audenaert et al., 2013), DOC and COD are good indicators of DOM oxidation by ozone. Fluorescence was strongly correlated with absorbance ( $0.91 > R^2 > 0.99$ ) (Figure 8). Similar trends with small differences in the slopes and intensities were observed between the treatments for normalised DOC and normalised COD with fluorescence, respectively. However, between fluorescence components there were quantitative differences (Figure 8). The correlation between fluorescence and absorbance, DOC, and COD, was component-dependent (**Paper III**).

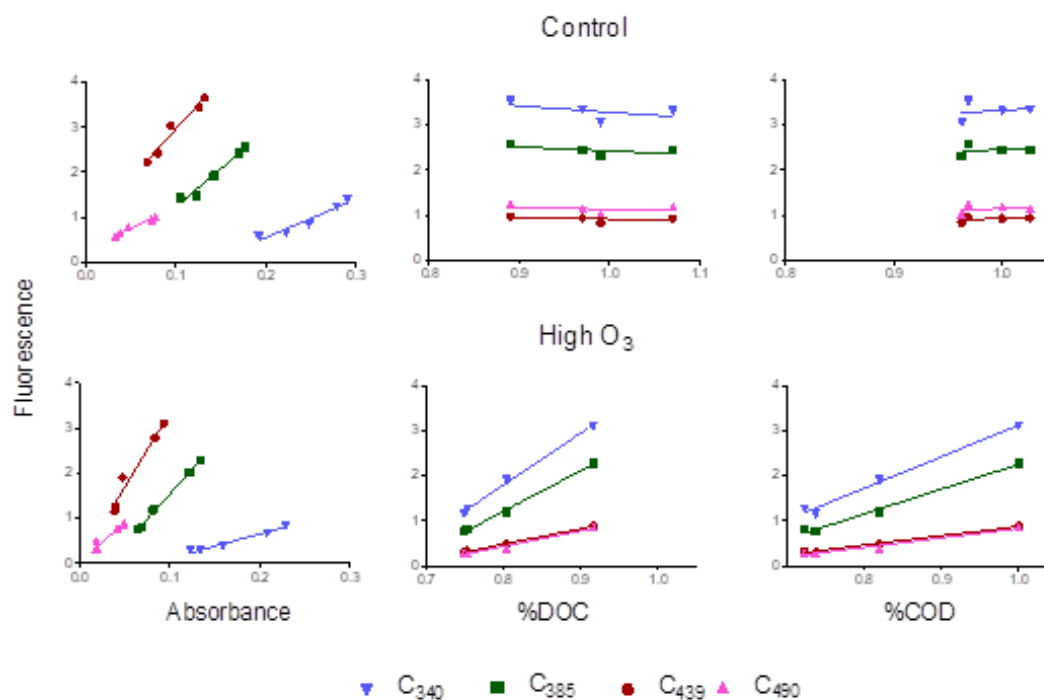

**Figure 8:** Fluorescence correlation with a) absorbance, b) normalised DOC and c) normalised COD<sub>TOT</sub> respectively and for each component for the 2 selected ozone treatments. Modified from **Paper III**.

RAS water is not a static molecular mixture, the distribution of FDOM changes significantly over time, affecting the overall fluorescence character of the water. Fluorescence is suitable to monitor changes in water quality due to the ability to detailed verify the distinct reactivity of identified fluorophores, which absorbance could not distinguish (Peleato et al., 2017).

Fluorophores were readily oxidised by ozone; however, variation was observed upon comparison of the slopes of the curves for both humic- and protein-like fluorescence, among the different water samples (**Paper I**). That suggests that a universal sensor utilising fluorescence removal to control dissolved ozone in water cannot be made. The fluorescence removal is not directly converted to ozone dosage (**Paper I**). Li et al. (2016) found it also difficult to compare intensities across wastewater studies. Correction factors are needed to directly compare results among sensors (Henderson et al., 2009). Therefore, a more accurate identification of the OM in a continually ozonated RAS, would provide a more precise fluorescence wavelength transition to manufacture a potential sensor (**Paper III**).

## 3.5 Applications of fluorescence measurement in ozonated RAS systems

A fluorescence based sensor could be applicable in both closed and flow through systems. Few studies have tested fluorescence based sensors within drinking water, wastewater treatment plants and aquaculture industries. A LED UV/fluorescence sensor predicted the DOM degradation during ozonation by measuring the  $UV_{289}$  and protein and humic-like fluorescence (Li et al., 2016). Another fluorescence method, processing all the emission fluorescence peaks excited at 254 nm as a whole (Gerrity et al., 2012), couldn't distinguish the oxidation behaviour between protein and humic-like fluorophores. Hambly et al., (2015) characterised the DOM in a conventional RAS using fluorescence EEM spectroscopy and PARAFAC analysis. This coupled EEM-PARAFAC methodology has been applied in several ozonated systems to investigate the removal behaviour of different fluorescent components (Liu et al., 2016; Chen, et al., 2017; Mangalgi et al., 2017; Peleato, et al 2017). However, any attempt has previously been made to investigate the FDOM changes in ozonated RAS.

### 3.5.1 Determination of delivered ozone dosage

Determination of the delivered ozone dosage is a common problem in various ozonation systems. Usually a sensor is installed in the gas flow of the ozone generator and another in the off gas flow from the ozone-water contact chamber. This set-up is however, an expensive solution. To evaluate the ozone system without any sensor installation (offline monitoring), water samples can be collected before and after the ozone injection (Figure 9a; blue dots: sampling locations), transferred to the laboratory. A calibration curve would directly convert fluorescence to ozone concentration for the specific system. Thus the ozone generator performance would be evaluated by comparing the obtained data with the manufacturer's specifications.

The determination of the OM character of a RAS and the sensitivity of each component to ozone would provide a new insight on the effectiveness of ozone treatment as a way to control organic matter in land-based aquaculture. This requires design of a fluorescence sensor based on a specific wavelength transition in order to monitor ozone (**Paper III**).

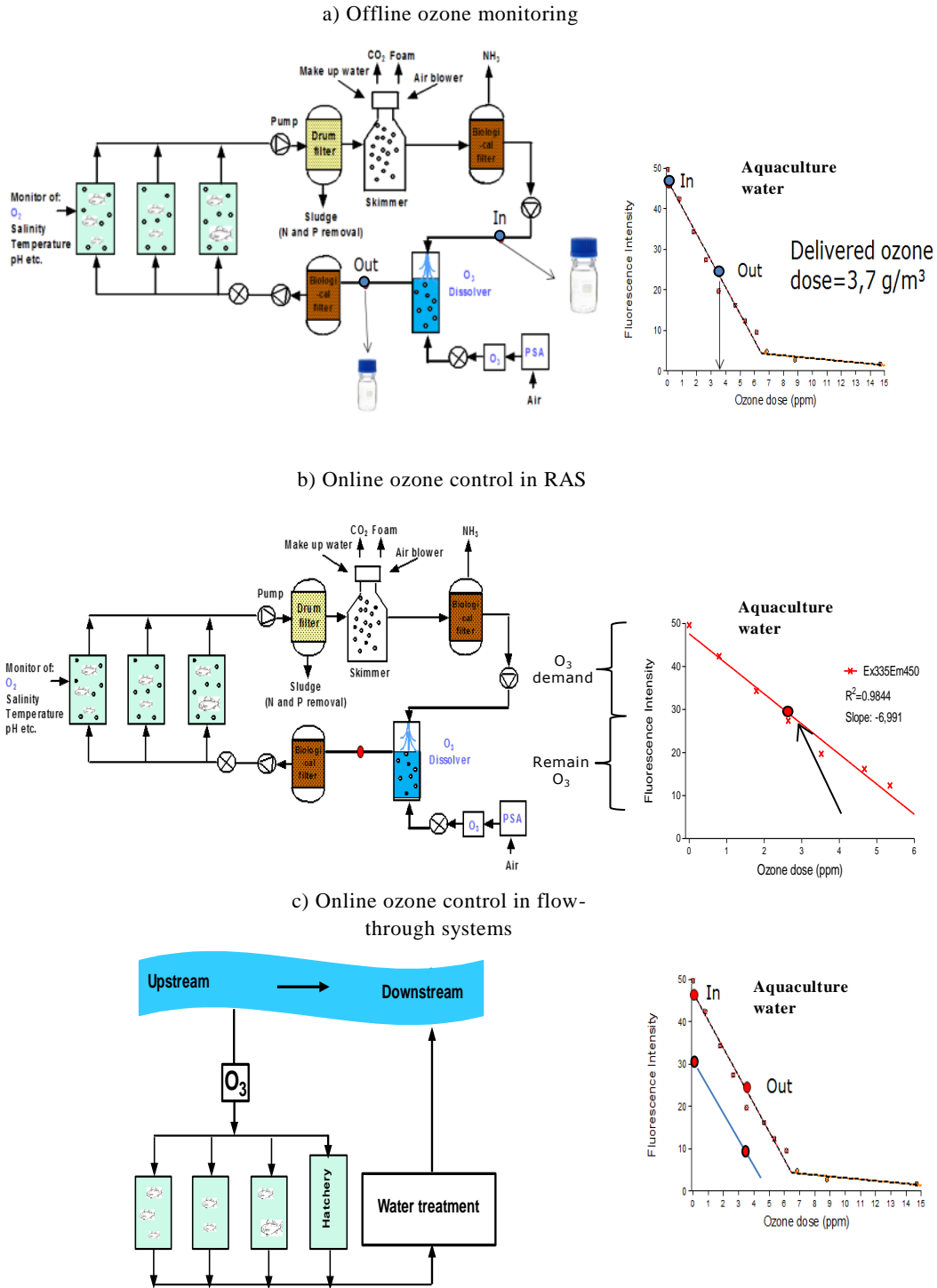

**Figure 9:** Schematic representation of potential fluorescence-based sensors applications to control ozone dosage in closed and flow through systems. These sensors can be either offline or online. From **Paper II**.

### 3.5.2 Online control in recirculation systems

An online control system equipped with fluorescence sensors will ensure that the ozone delivered in the water will be within predetermined levels. A fluorescence intensity within the calibration curve will be chosen as a control point (Figure 9b), and would fluctuate within a predetermined range. When fluorescence intensity exceeds that threshold, ozone will be dosed accordingly to maintain the fluorescence within the limits. With this approach, the ozone demand will be well defined preventing excess of ozone into water. Although the water quality will be improved, the disinfection will be limited. An additional benefit of this concept is the low operational cost since only the required ozone dosage will be injected.

### 3.5.3 Online control in flow through systems

Ozone dosage control, based on fluorescence spectroscopy, is a technique that can be also applied in “flow-through” systems (Figure 9c). An online sensor installed in the inlet of the facility would evaluate the influent water quality in terms of fluorescence intensity. Based on the fluorescence intensity, the ozone generator will be adjusted as described previously, oxidising pesticides and miscellaneous micro-pollutants and deactivating pathogens that the water stream might carry on and which might be harmful to the facility. A second sensor in conjunction with the ozone generator will ensure no residual ozone is left.

Alternatively, the same set up can be installed in the outlet of the facility, before water is discharged to the environment to ensure that chemical compounds used within the facility (e.g. antibiotics or other chemicals) are oxidised and consequently absent from the water stream. The purpose of this approach is to constantly ensure that certain thresholds are met independent on inlet water quality (blue line; Figure 9c). If fluorescence intensity is lower than the predetermined fluorescence level in the effluent, then less ozone should be fed into the system.





## 4 Safe design of ozonation installations

Although ozonation has been applied for years in aquaculture, there is still knowledge gap regarding the realistic “safety window” (Muller and Milton, 2012). The added amount of ozone required is system-specific and highly dependent on the “ozone demand” which depends on the feed loading, feed utilisation, water treatment, degree of dilution, etc. (Summerfelt et al., 2009). The ozone demand and the ozone lifetime are key parameters to design a safe ozonation system (Figure 10). Therefore, a method to predict the required ozone dosage in a RAS by analysing water samples in the laboratory was developed (**Paper II**) setting the basis for better design of pilot and full-scale systems with the minimal risks and cost and the closest proximity to the facility’s needs.

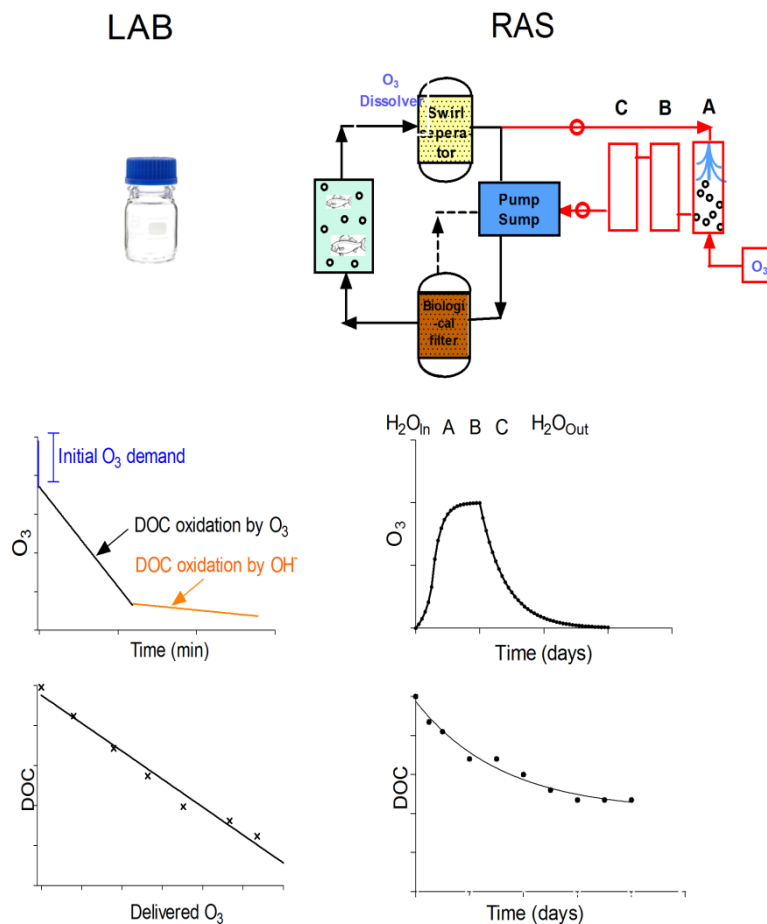

**Figure 10:** Illustration of the principle to design an ozonation system for a RAS by analysing water samples in the laboratory.

## 4.1 Optimal ozone dosage for pilot RAS

Ozone demand and kinetics in RAS water were determined. Water samples were collected occasionally from a pilot-RAS (Figure 11), starting from the day that the fish entered the tanks (0 days) until the system reached steady state (70 days) and then were subjected to recurrent ozonation (bench scale experiments; **Paper II**). Prior to ozonation, the systems had reached steady state in terms of biofilters performance (Colt et al., 2006).

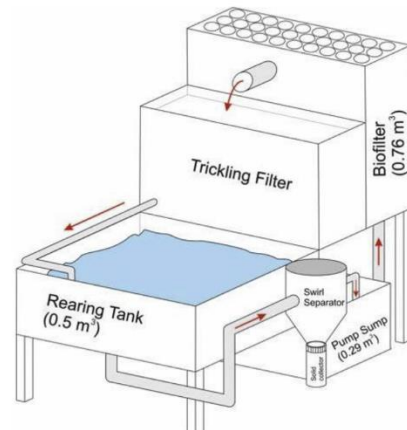
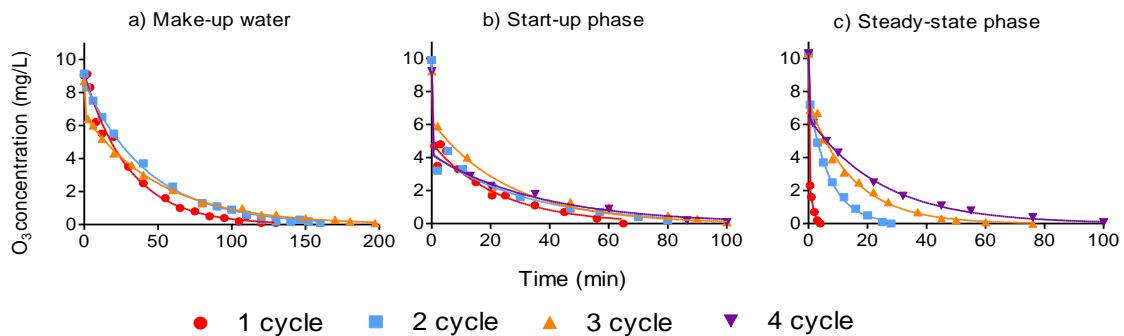

**Figure 11:** Schematic representation of a pilot-RAS (Rojas-Tirado et al., 2017).

### 4.1.1 Ozone kinetics and organic matter

The lifetime of ozone is important to know to ensure safe and optimal dosage. Ozone should be completely degraded before the treated water reaches the culture tanks or even the biofilters. To investigate the long-term effects of ozone, water samples were repeatedly ozonated (10 mg O<sub>3</sub>/L) upon ozone depletion (Figure 4). Distinct fluorescence removal was observed among the cycles (each cycle means addition of 10 mg O<sub>3</sub>/L). A correlation between the ozone dosage applied and the fluorescence removal was found (**Paper II**).

The recurrent ozonation simulated water recirculation. In presence of low OM (e.g. make-up water), the ozone lifetime did not vary between cycles (>130 min), suggesting that there was not enough OM to react with ozone, extending its lifetime (Figure 12a). High OM concentration samples had remarkably shorter lifetimes (< 5min; Figure 12c). The three following ozone cycles had considerably longer lifetimes compared to the start-up phase and make-up water. More recalcitrant compounds were oxidised by the subsequent ozone cycles (**Paper II**).



**Figure 12:** Ozone kinetics of RAS water during 4 consequent dosings (i.e. cycles; addition of 10 mg O<sub>3</sub>/L per cycle) in a) make-up water, b) start-up phase and c) steady-state phase. Expected nominal concentrations of ozone was equivalent to 10 mg O<sub>3</sub>/l. Modified from **Paper II**.

#### 4.1.2 Ozone demand

Ozone reacts rapidly with the easily degradable compounds, resulting in an immediate ozone consumption (time = 0 min; Figure 12) which will be referred to herein as “initial ozone demand”, and is correlated to the increasing water pollution due to OM accumulation in the system. The greater initial ozone demand was observed in high OM concentration water samples.

Several methods have been suggested over the years regarding the issue of ozone demand determination. It has been suggested to dose ozone based on ORP levels, feeding (Bullock et al., 1997; Good et al., 2011) or automatically adjusted to either changes in fish feeding ratio (Summerfelt et al., 2009) or FDOM degradation (Paper I).

The fluorescence intensity, which reflects the OM accumulation in a system, can be used to indirectly determine the ozone applied in a RAS (**Paper II**). The ozone demand for the pilot RAS was exclusively defined based on feed input and the associated metabolic excretion, as the make-up water had no initial ozone demand (Figure 12). In **Paper II**, it was described in detail how the ozone demand was determined, by taking into account ozone demand for the start-up phase and the steady state as well as the ozone lifetime.

Water samples were collected from a replicated experimental setup (Rojas-Tirado et al., 2016), built to mimic full scale intense RASs (Figure 13). The RAS used freshwater (non-chlorinated ground-water) supplied through the public distribution system in Hirtshals, Denmark. Upon recurrent ozonation, the 2<sup>nd</sup>, 3<sup>d</sup> and 4<sup>th</sup> cycles overlapped (each cycle means addition of 10 mg

$O_3/L$ ; Figure 12), as no further reaction occurred. Thus, the ozone demand for the start-up phase (OM built-up in 7 days) was around 18 mg  $O_3/L$  (between 10 and 20 mg  $O_3/L$ ). Likewise, the ozone demand for the steady state (OM built-up in 70 days) was around 35 mg  $O_3/L$ . Afterwards, the daily ozone demand for each phase was calculated to be 2.6 and 0.50 mg/L/day, respectively. By taking into account system's configuration (e.g. volumes, flows) it was found that 148 mg  $O_3/h$ , which correspond to 28 g  $O_3/kg$  of feed, was needed for the specific RAS. If this ozone dosage would be applied continually, the OM in the water would be completely oxidised. Addition of 15 to 25 g  $O_3/kg$  of feed was sufficient to improve water quality in full-scale ozonation systems (Summerfelt & Hochheimer, 1997; Summerfelt et al., 2009; Davidson et al., 2011). Although, RAS water should be of good quality, it should not be pathogen free, since the immune system of the fish would be completely weakened. Thus, lower ozone dosages than the calculated (28 g  $O_3/kg$  of feed) were applied in the pilot-RAS; 10, 15 and 26 g  $O_3/kg$  of feed (**Paper II**).

The ozone demand and the ozone lifetime for the specific system were determined experimentally in the laboratory, the predicted ozone dosages applied in up-running pilot-RASs (Figure 13) aimed to test the methodology and to verify the effect of ozone on water quality.



**Figure 13:** The pilot-RAS facility where the experiment was conducted in Hirtshals, Denmark.

# 5 Ozonation of freshwater pilot-RAS

## 5.1 Ozonation of pilot-RAS

The predetermined ozone dosages (Section 4.1.2) were injected into pilot-scale RASs (Figure 13). The ozone pilot-scale trial lasted 2.5 weeks, and the overall experiment was divided into three distinct phases. Phase I was the pre-ozonation period (6 months), while Phases II and III represented the two ozonation periods. During Phase II, two replicated trials occurred (II<sub>A</sub> and II<sub>B</sub>).

For the Phase II<sub>A</sub> six RASs were used, three were operated as controls, where no ozone was added. The three remaining RASs were each equipped with one ozone reaction tank (18 L) per system (Figure 14). In a side-stream, water was pumped from the swirl separator into the reaction tank at a flow of 0.2 m<sup>3</sup>/h and a retention time of 5.4 min. The remaining water was led to the pump sump. From the ozone reaction tank, the treated water was also transferred to the pump sump with an overflow, before moving on through biofilters (excess water from the trickling filter returned to the pump sump) and ultimately to the fish tank. For the Phase II<sub>B</sub> six new RASs were used. In Phase III, 50 g O<sub>3</sub>/ kg of feed, equivalent to twice as much as the highest applied ozone dosage in Phase II, was tested (High O<sub>3</sub> x2). The control values consisted of the average for the three individual systems. The study relied mainly on the results from the Phase II, as there were some malfunctions in the ozone delivery system during the first trial.

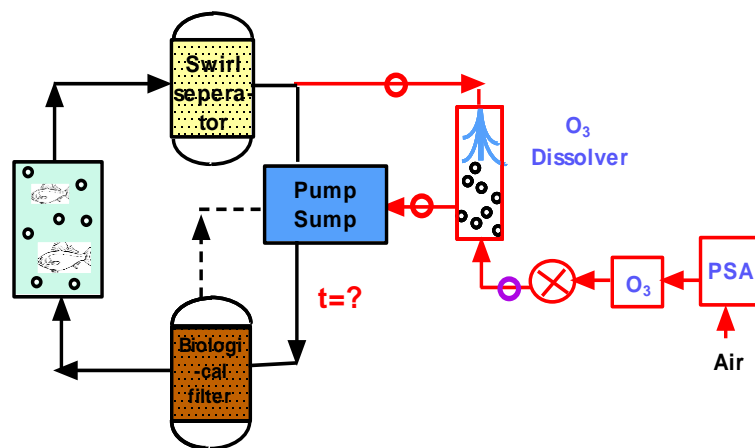

**Figure 14:** Schematic representation of the pilot-RAS (black lines) with the integrated ozone (red lines).

## 5.2 Ozone effect on water quality

Water was tested several times per day, in multiple locations within the RAS, for residual ozone. If residual ozone is present in culture tanks might affect the fish physiology (damages on tissues or gills or even kill the fish; Powell and Scolding, 2016) or behaviour (feeding and/or swimming; Bullock et al., 1997). By using the indigo method (Section 2.3.2), no ozone residues were detected in any RAS at any time and consequently none of these adverse effects were recorded. Along with the residual ozone, several water parameters were determined during the pilot ozone experiment (Figure 15).

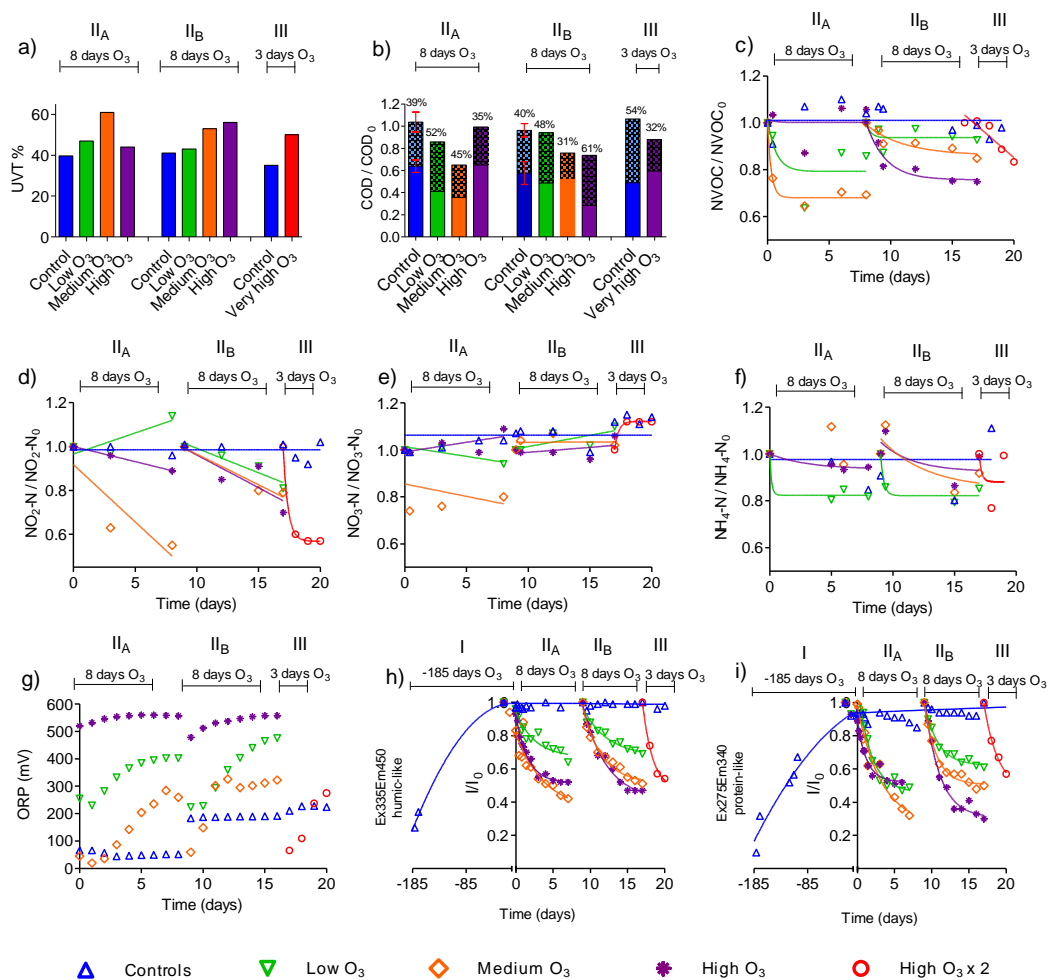

**Figure 15:** Effect of ozone on a) UVT% after 8 days, b) COD after 8 days (the % and the dotted (upper) parts of the bars represent the particulate COD, while the lower part is dissolved COD-normalised data, standard deviation only in control, c) NVOC-normalised data, d) nitrite-normalised data, e) nitrate-normalised data, f) ammonium-N-normalised data, g) ORP, h) protein like-fluorescence-normalised data and i) humic-like fluorescence degradation-normalised data from **Paper II**.

### 5.2.1 Ozone effect on water transparency

Water transparency is vital for RAS management. The fish can see the feed, resulting in increased growth with limited feed waste. Increased visibility can also improve UV treatment efficacy and several water treatment processes within the unit. Water transparency is a good indicator of water quality and is described by the transmission of UV<sub>254</sub> (UVT), which represents the amount of light absorbed by particles and dissolved substances within a sample. In RAS water, typical range for UVT% is from 30 to 60% (**Paper II**). The water clarity, expressed as UVT% (Figure 15a), increased pro rata of ozone dosage applied and treatment period (Summerfelt et al., 1997; Christensen et al., 2000; Summerfelt et al., 2009; Davidson et al., 2011; **Paper II**).

### 5.2.2 Ozone effect on Oxidation - Reduction potential (REDOX)

ORP was continually monitoring determined to the baseline of RAS water and the resulting changes due to ozonation to facilitate the comparison with previous studies. ORP probes are often used as part of feedback mechanisms to aid in adjusting ozone dosages to the ozone generator (Powell and Scolding, 2016). Although, the RASs used for the experiment were identical, the REDOX potential did not have the same starting point (**Paper II**) which is a well-known issue. Different safe ORP levels for rainbow trout have been reported; 250 mV (Davidson et al., 2011), 300 mV (Bullock et al., 1997), and 340 mV (Summerfelt et al., 2009). However, ORP levels and consequently ozone dosage cannot be compared across studies (Li et al., 2014), since each water type is unique and changes are observed even in non-ozonated RAS water. These changes might be due to different water compositions, system designs, probe specifications and calibration times (Li et al., 2014) to feeding, waste production cycles, oxygen levels and treatment system.

The ORP baseline the pilot RAS experiment was at 200 mV. The REDOX potential increased proportionally to ozone dosage, ranging from 475 to 549 mV (Figure 15g). Similar REDOX levels (375, 450 and 525 mV) have also been observed in an earlier study when similar dosages were applied (24-32 g O<sub>3</sub>/kg of feed; Summerfelt et al., 1997).

### 5.2.3 Ozone effect on organic matter

Bulk indicators of water quality such as NVOC, COD and BOD have been widely used in RAS to determine DOM (Hambly et al., 2015; Rojas-Tirado et al., 2017). During the 70-day period, the NVOC was increased by 6.9 mg/L (filling water to steady state (**Paper II**)), due to fish activity, feed loading and high system intensity. Such high NVOC concentrations, up to 9.7 mg/L, have been found in commercial trout RAS (**Paper I**). Upon ozonation, NVOC concentration diminished (Figure 15c) by 25% (high dosage, II<sub>B</sub>). A rapid decrease was observed within the first days, following first-order decay. In the Phase III, NVOC reduction (17%) was proportional to ozone exposure (**Paper II**). Low weight assimilated organic carbon or biodegradable OM is produced when DOM is oxidised by ozone. However, low ozone dosages were not able to break down the molecules. In the contrary, ozone may have enlarged the molecules by breaking double bonds and adding oxygen atoms in the parental compound and forming a secondary molecule with higher molecular weight (Von Sonntag and Von Gunten, 2012). These enlarged compounds possibly would be removed by filtration and sedimentation or be readily degraded by bacteria, since the newly-formed hydroxyl groups are easier to break down.

A supplementary parameter to quantify oxidisable OM in water is the COD. The dissolved fraction was the dominant (Figure 15b). Due to short-term treatment, the ozone effect on COD was not clear while there was variability in the control samples (standard deviation in control samples; Figure 15b).

A similar trend to the COD was observed when BOD<sub>5-TOT</sub> (**Paper IV**) was analysed. BOD<sub>5-TOT</sub> removal was also proportional to ozone dosage, with a decrease from 30 to 39% (Figure 16b). The particulate fraction of the BOD<sub>5-TOT</sub> dominated and was significantly reduced by ozone. The BOD<sub>5-DISS</sub> was much lower without being affected by the treatment.

The biodegradability index, defined as the ratio between BOD and COD (BOD/COD), can be used to characterize the OM in water (**Paper IV**). Srinivas (2008) has suggested the following classification: if BOD/COD is >0.6 the OM is easily biodegradable, if BOD/COD is between 0.3 and 0.6, the OM is average biodegradable, and if BOD/COD is <0.3 the OM is not easily biodegradable. The mean biodegradability indices for BOD<sub>5-TOT</sub>/COD<sub>TOT</sub> prior and upon ozonation were  $0.10 \pm 0.03$  and  $0.10 \pm 0.01$  (independent on the ozone dosage applied), respectively. The RAS water contained recalcitrant or non-biodegradable organic matter (Srinivas, 2008; Dalsgaard and Pedersen,



2011). In RAS systems operating under constant conditions for a long period the biodegradability index have been reported to range from 0.08 to 0.1 (Fernades et al., 2015; Rojas-Tirado et al., 2017; 2018).

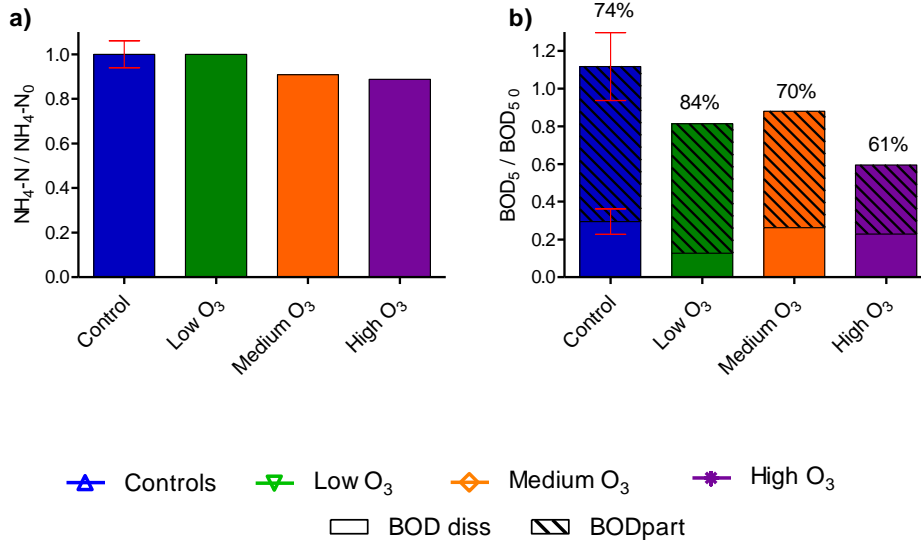

**Figure 16:** Effect of different ozone dosages, after 8-day-treatment, for the Phase II, on a) TAN, these data could be also found in Paper II, b) BOD<sub>5</sub> (the % and the stripped (upper) part of the bars represents the particulate BOD<sub>5</sub>, while the lower part is dissolved BOD<sub>5</sub>) in RAS water. The data are normalised and standard deviation applied only in the controls. Modified from **Paper IV**.

## 5.2.4 Ozone effect on fluorescent organic matter

The effect of continuous ozonation on FDOM character in aquaculture water from constant operated RASs was investigated (Figure 15 h,i). A more detailed identification of the different fluorescent fractions was conducted by using the coupled EEM-PARAFAC technique (**Paper III**). The most pronounced components in untreated water samples were C<sub>439</sub> and C<sub>385</sub>, whereas C<sub>490</sub> and C<sub>340</sub> were present at lower intensities. A few hours after ozone injection in the systems, no difference were observed between the control, low and medium ozone treatments for the C<sub>439</sub> and C<sub>385</sub> (Figure 17). A decrease was observed for each fluorescence component during the same period for the high ozone dosage treatment (Figure 17). Both C<sub>490</sub> and C<sub>340</sub> found to differentiate from the control, where the relative decrease was correlated to the ozone treatment concentration.

The relative decreases were most pronounced with the highest ozone dosages, and the level of the decrease was directly related to the level of ozone dosage.

Towards the end of the trial, the systems appeared to reach a new steady-state in terms of FDOM, which became more pronounced as the ozone dosage increased. This suggests that the rate of FDOM input to the system became equal to the rate that ozone was removing it. The time that the steady-state occurred for each one of the four fluorescence components differed.

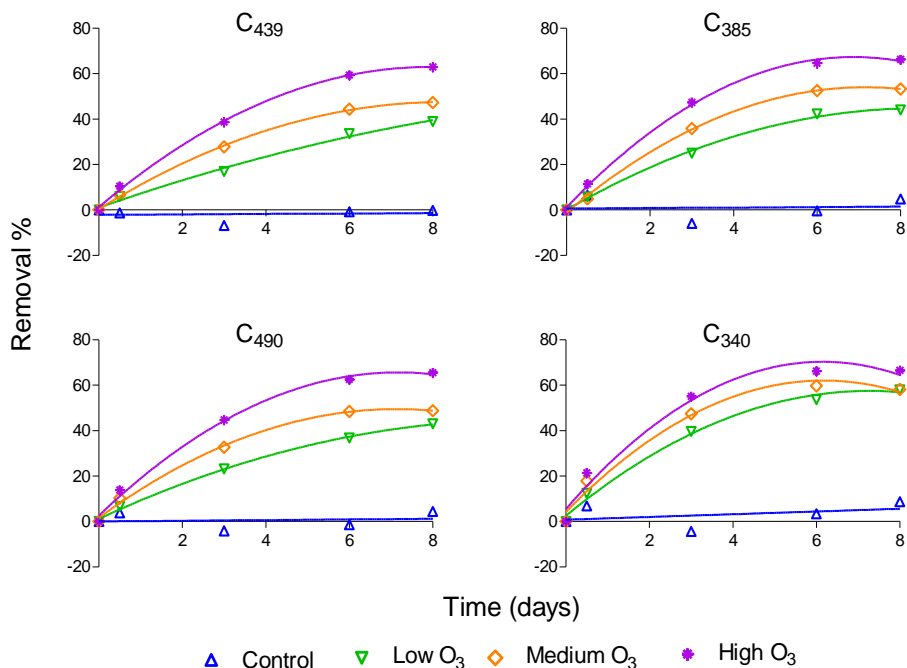

**Figure 17:** Relative removal of FDOM components by ozonation over time for 4 ozone treatments, from **Paper III**.

### 5.2.5 FDOM component selectivity

The removal rates of FDOM varied between components suggesting that they responded differently to ozone. This provided details about their bioavailability and treatability. Fluorophores with emission peaks in the visible region are often described as humic-like or fulvic-like, are ubiquitous (freshwater, coastal waters, ground water and deep ocean waters) and are consisting possibly of aromatic rings and electro-donating groups (Li et al., 2016). PARAFAC analysis revealed three different signals within the visible region. These fluorophores often represent persistent OM which has been accumulated over time as by-product of microbial activity (Jørgensen et al., 2011). Marine microorganisms are not able to decompose components such as C<sub>439</sub> and C<sub>385</sub>, and it is believed to be the leftovers of microbial processing (Riopel et al., 2014; Yamin et al., 2017). These components appear similar recalcitrance

towards ozone (Von Sonntag and Von Gunten, 2012; **Paper III**). Between the humic like components contained in our RAS water, the highest removal was observed by the  $C_{385}$  (**Paper III**). Components with shorter wavelength transitions and most probably lower molecular weight (Fellman et al., 2010), might be more amenable to oxidation by ozone (Peleato et al., 2017).

In intensive aquaculture systems, water may be enriched with peptides or metabolized proteins due to fish excreta and dissolution of fish feed. High UV-A fluorescence signal is linked to the amino acids, is then expected (Yamashita et al., 2013). UV-A fluorescence signal is commonly attributed to fresh, highly bioavailable (many bacteria utilise tryptophan and tryptophan as a food source) and degradable DOM, and therefore it is often associated with biological activity and growth (Logue et al., 2016; Sorensen et al., 2018). This component is usually present in surface waters (Fellman et al., 2009; Stedmon and Cory, 2014) and wastewater effluents (Baker & Spencer, 2004; Hambly, et al., 2010; Hambly, et al., 2012; Riopel et al., 2014). It is a fraction that can affect the microbial water quality and the microbial community. Therefore, the immediate limitation of this component within RAS might also affect heterotrophic micro-organism growth. For all ozone dosages, and at all-time points,  $C_{340}$  exhibited the greatest % removal of all components (Figure 17). Previous studies have shown that ozone preferentially reacts with molecules with higher electron density (Von Sonntag and Von Gunten, 2012; Mangalgi et al., 2017) and is therefore consistent with the link to tryptophan content of this component.

### 5.2.6 Component removal rates

Ozone oxidizes DOM based on the functional groups of the organic molecules. DOM is a complex mixture of millions of different chemical compounds – with different reactivity and bioavailability. The FDOM components exhibited different reactivity with ozone, having distinct removal rates. The FDOM removal was proportional to the applied ozone dosage. The longer wavelength components ( $C_{439}$ ,  $C_{385}$ ,  $C_{490}$ ) were more recalcitrant to ozone compared to the shorter wavelength UVA component ( $C_{340}$ ; **Paper III**). Similar observations were found in ozonated OM extracted from poultry litter where the protein-like fluorophores were the first to be removed upon ozonation and with the fastest rate (Mangalgi et al., 2017).

In overall, the humic-like components had higher fluorescence intensities and were characterised by higher sensitivity compared to the protein-like component ( $C_{340} < C_{490} < C_{385} < C_{439}$ ; Figure 18).  $C_{340}$  component is also associated with microbial activity and BOD (Cumberland et al., 2012a). In combination with the removal rate upon ozonation it becomes a key element for the monitoring and optimisation of ozone treatment in RAS.

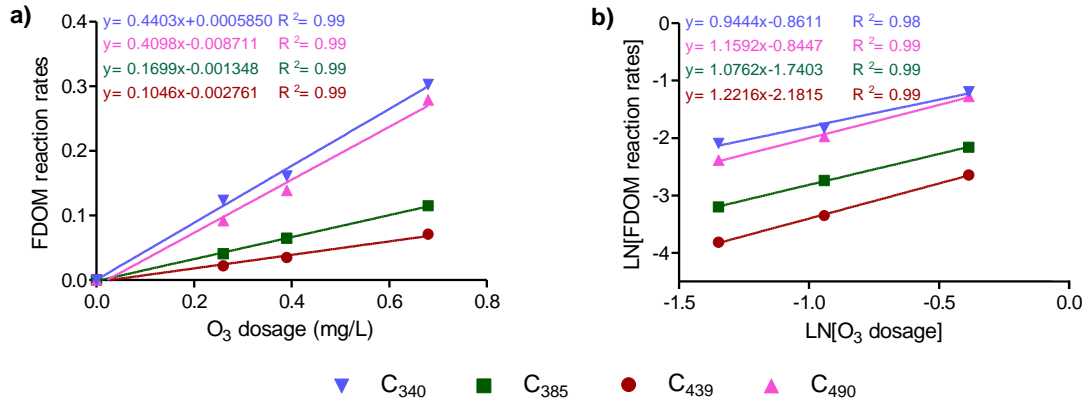

**Figure 18:** a) Reaction rates; and b) log-log graph showing rate order; according to ozone dosage for each FDOM component from **Paper III**.

### 5.2.7 Ozone effect on particles

RAS water was also analysed for particle numbers and size distribution in samples only from the Phase II<sub>B</sub> (**Paper IV**). Particles allow bacteria to be adhered having a positive correlation with bacterial activity (Pedersen et al., 2017). Prior to ozonation the particle numbers varied from  $1.36$  to  $4.88 \times 10^6$  particles/ml and from  $1.47$  to  $2.78 \times 10^5$  particles/ml, for the size class 1-3  $\mu\text{m}$  and 3-30  $\mu\text{m}$ , respectively (Figure 19).

Upon 8 days of ozonation the micro-particles with size between 1-3  $\mu\text{m}$  were decreased evenly in the control and the low ozone dosages, while a slight decrease was observed in the medium ozone dosage. The high ozone dosage resulted in a reduction of 72% of micro-particles in this size range after 8 days of continuous ozonation. Davidson et al. (2011) observed the same effect on micro-particles when applying 20-25 g  $O_3$ /kg feed.

Particles in the range 3-30  $\mu\text{m}$  also decreased at the end of the trial, proportionally to the ozone dosage applied, from 66 to 86%. The reduction could be explained by the ability of ozone to reduce suspended particles, (Summerfelt et al., 1997), improving the filter performance. The breakdown of micro-

particles was significant for the high ozone dosage (26 g O<sub>3</sub>/kg feed) and very consistent with the BOD and COD removal.

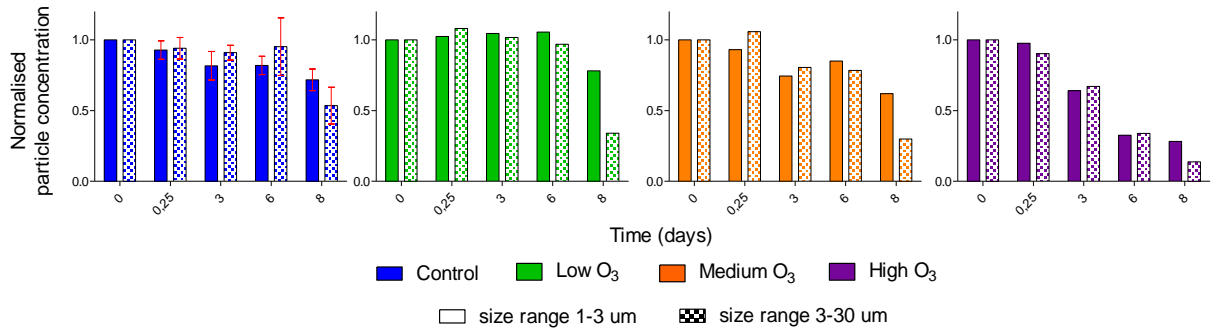

**Figure 19:** Effect of different ozone dosages on particle size distribution (ranges 1-3 μm and 3-30 μm) and number - normalised data. Modified from **Paper IV**.

### 5.2.8 Ozone effect on nitrogen-based compounds

A large part of dissolved waste in RAS comprises nitrogenous compounds in the form of ammonia, ammonium, and urea (Bureau and Hua, 2010; Dalsgaard et al., 2015; Dalsgaard and Pedersen, 2011). Biofiltration is a key process in RAS water quality management. After the ammonia release, which is highly toxic for the fish, bacteria in the biofilters will convert it to nitrite, which is still dangerous to the fish (Kroupova et al., 2005; Svobodová et al., 2005), and then to nitrate, which is relatively non-toxic. Finally, a denitrification filter will transform nitrate to nitrogen gas, which is released to the atmosphere.

The presence of high OM can affect the biofilter performance (Guerdat et al., 2011). Other bacteria, competitive to nitrification bacteria, might start using the OM as carbon source (Blancheton et al., 2013), grow faster and replace the nitrification bacteria (Grady et al., 2011). Therefore it is crucial to maintain the ammonia and nitrite levels in low concentrations as well the OM content in the water to ensure that the biofilters will operate satisfactorily.

Although ozone was able to oxidize OM in a great extent (**Paper II; Paper III**), its effect on nitrite was limited (20% removal) independent on the ozone dosage (Figure 13d). No effect was observed on nitrate (Figure 15e) and ammonia removal (Figure 15f, 16a). Ammonia is not readily oxidised by ozone (Timmons et al., 2002), unless pH levels are 9 or above (Rice et al., 1981). Nitrification and denitrification in the biofilters appeared unaffected as ammonium and nitrate concentrations in the system water did not change during the experimental ozone treatment.

## 5.3 Ozone effect on microbial water quality

In RAS, the microbial abundance is highly related to the availability of dissolved and particulate biodegradable OM, which is the main nutrient source for heterotrophic bacteria (Wold et al., 2014; Attramadal et al., 2016). Bacteria lead to high levels promoting growth of heterotrophic dinoflagellates can be toxic and might cause complete loss of fish (Moestrup et al., 2014) with large economic impact. The oxidative properties of ozone are able to reduce either the absolute numbers of bacteria or the pathogens infectivity, proportionally to the contact time (Langlais, et al., 1991; Powell et al., 2015). An investigation regarding the microbial activity and abundance in the RAS water upon ozonation was also conducted (**Paper IV**).

Usually the bacterial loading in RAS has been assessed by the use of plate count agar methodology (colony forming units; CFU) (Sharrer et al., 2005; King et al., 2006; Sharrer & Summerfelt, 2007; Attramadal et al., 2012; Garrido-Pereira et al., 2013). This technique has low representativeness and long response time (Van Nevel et al., 2017). In the present study the microbial water quality was assessed through quantification of bacteria in terms of i) activity by the BactiQuant<sup>®</sup> method and hydrogen peroxide degradation method (Rojas-Tirado et al., 2017; Rojas-Tirado et al., 2018) and ii) cell number with flow cytometry (Figure 20) prior and after 8 days of ozonation. These techniques were used to assess disinfection efficiency rapidly, which has not been done before.

### 5.3.1 Bacterial activity

Both methods, HP degradation and BactiQuant<sup>®</sup> analyses, are assays that measure water samples (Rojas-Tirado et al., 2018) and take into consideration the activity of free-living and particle associated bacteria (Pedersen et al., 2017; Rojas-Tirado et al., 2018). BactiQuant<sup>®</sup> measures bacterial activity indirectly via a common hydrolase enzyme found within a wide range of bacteria (Reeslev et al., 2011) which will remain active in the presence of available substrate (Rojas-Tirado et al., 2018), while the hydrogen peroxide degradation assay is based on microbial degradation kinetics (Arvin and Pedersen, 2015).

The control RAS increased in average two times in bacterial activity compared to the initial values (Figure 20), while a slight increase (10 and 30%) was observed for the low and medium ozone dosages. Assessing the bacterial

activity by HP degradation, after 8 days of trial, it was observed that the high ozone concentration reduced the activity by 20 %. Bacterial activity within RAS prior to treatment, assessed by BactiQuant<sup>®</sup>, had the same values as in previous studies where RASs were in steady state (Pedersen et al., 2017; Rojas-Tirado et al., 2018). Despite the different ozone dosages applied to RAS, no significant inhibition of bacterial activity measured by BactiQuant<sup>®</sup> was observed (Figure 20).

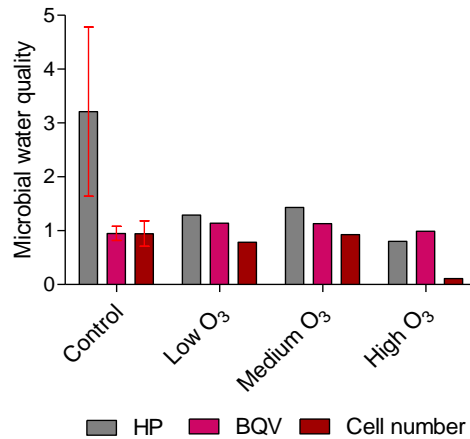

**Figure 20:** Microbial water quality results measured with different methodologies: a) Bacteria activity measured with HP degradation assay; b) bacterial activity measured with BactiQuant<sup>®</sup>; and c) bacterial abundance measured with flow cytometry. Data are normalised and standard deviation was applied only in the controls, from **Paper IV**.

A reason why bacterial activity apparently was not affected by ozonation could be that the ozone system was primarily designed to enhance the water quality and not necessarily to provide disinfection (**Paper II**); no residual ozone was left in the water at the end of the ozone contact tank. Furthermore, the RASs varied greatly in terms of bacterial activity prior to ozonation making the observations upon ozonation difficult, requiring data normalisation.

An additional reason might be that ozone may have broken down organic matter to smaller molecules, exposing new available substrate for bacteria to either adhere to or be embedded in particles protecting them from disinfection (Hess-Erga et al., 2008). In case of the high ozone concentration, it could have induced to micro-flocculation of small particles into bigger particles (Tango and Gagnon, 2003; Gonçalves and Gagnon, 2011) maintaining possibly bacterial activity. Few studies support that OM accumulated in RAS, protect the fish from parasites and microorganisms (Yamin et al., 2017a; 2017b).

### 5.3.2 Bacterial abundance

The total number of suspended bacterial cells was quantified by flow cytometry using a fluorescent dye (SYBR Green II). Flow cytometry is based on single cell level (Rojas-Tirado et al., 2018). No treatment that would cause cell detachment from particles occurred. Thus, the data are referred to as “free-living bacteria”.

Conversely to bacterial activity, the free living bacteria, measured by flow cytometry, were significantly reduced by ozonation. The reduction in bacterial abundance was proportional to ozone dosage level (Figure 20). The highest O<sub>3</sub> dosage reduced the free-living cell up to 89% after 8 days of constant ozonation.

The retention time of water in the ozone reaction tank was 5.4 min (**Paper II**) meaning 1.40, 2.11 and 3.67 mg O<sub>3</sub> min/L were dosed depending on the dosage. Different ozone dosages have been used for disinfection, depending on the target microorganism, ranging from 0.1-2 mg O<sub>2</sub> min /L (Summerfelt et al., 1997). The reduction of free living bacteria and persistent bacterial activity could be attributed to the possible flocculation of micro-particles into larger particles (> 30 µm). This may have sustained further particulate bacterial growth and protection. Bullock et al. (1997) used ozone dosages from 25 to 39 g O<sub>3</sub>/kg feed without providing even a 1 log<sub>10</sub> reduction in heterotrophic bacteria count in RAS water. Hess-Erga et al. (2008) observed larger inhibition of the free living than particle associated bacteria when applying ozone being in agreement with our findings. The particle associated bacteria are protected by the structure of the particles. Greater bacteria reduction within RAS would have required higher ozone concentration i.e. above 39 mg O<sub>3</sub>/kg feed (Bullock et al., 1997) or the use of a protein skimmer to improve micro particle removal, and eventually reduce the particle associated bacteria.

Due to variations of microbial loadings in the tanks prior to the treatment, further investigation is needed to assess the microbial quality parameters in ozonated RAS with methods such as BactiQuant<sup>®</sup>, HP and flow cytometry.



## 6 Ozonation of marine RAS

Ozone chemistry in saltwater is more complex compared to that in freshwater, due to the higher concentrations of dissolved anions and cations (Jung et al., 2017). Bromide ( $\text{Br}^-$ ) is present in freshwater and seawater at concentrations ranging from 10 to  $>1000 \mu\text{g/L}$  and about 67 mg/L, respectively (Magazinovic et al., 2004). Bromide is highly reactive with ozone. When ozonating seawater, bromide ion ( $\text{Br}^-$ ) is oxidized to bromate ( $\text{BrO}_3^-$ ) with intermediate steps (Eq. 4-6). Hypobromous acid (HOBr) and its dissociation form, hypobromite ( $\text{OBr}^-$ ), are the dominating bromine species in water (Eq. 7) and are of crucial importance since they have long lifetime allowing to several side reactions to occur (Grguric et al., 1994; Wert et al., 2008).  $\text{OBr}^-$  also reacts with ammonia and proteins to form bromamines ( $\text{R-NBrH}$ ; Eq. 8).



Ozonation in seawater RAS aims to mainly oxidise OM rather to disinfect (Summerfelt, 2003; Tango and Gagnon, 2003). Disinfection requires high amount of ozone which raises the risk to form bromine-oxides. Both bromamines and hypobromous acid are toxic to fish, bivalves and crustaceans (Crecelius, 1979; Heeb et al., 2014). Marine animals, *Neomysis awatschensis* and *Oncorhynchus keta* tested for bromate toxicity and it was found to have a 24-h  $\text{LC}_{50}$  of 176mg/L bromate and a 96-h  $\text{LC}_{50}$  of 512mg/L bromate, respectively.

To investigate the ozone fate and behaviour in marine water, samples were collected from a public aquarium, and were ozonated in the laboratory. The water quality was not evaluated since advanced water treatment technology is installed. The DOC of the samples was extremely low. Therefore, the interest was merely on the ozone determination and its lifetime in salt water. When ozonating seawater, it was observed that the lifetime of ozone, determined by the indigo method (Bader and Hoigné, 1981), was extremely long (Figure 19). Similar long lifetimes were found in ozonated distilled water when bromide was added, confirming that ozone reacts with the bromide forming brominated by-products that interfere with the indigo (Figure 21).

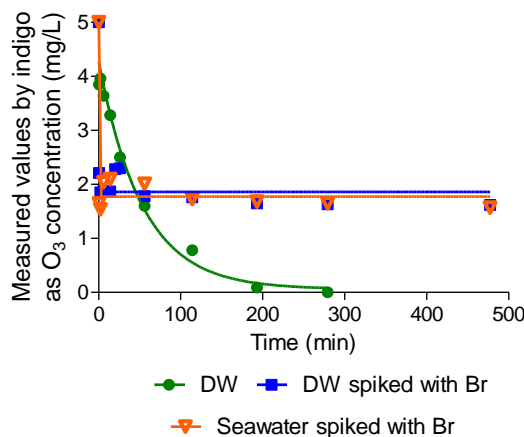

**Figure 21:** Kinetics of ozonated (5 mg O<sub>3</sub>/L) a) distilled water b) distilled water spiked with bromide and c) seawater water spiked with bromide. All samples were pH adjusted to 7.3.

Two strategies have been suggested to minimize bromine by-products; the removal of precursors or the control of by-product formation (von Gunten and Hoigné, 1994). Some of the methods applied to resolve the issue are ammonia addition, pH depression, OH radical scavenging, scavenging or reduction of hypobromous acid (HOBr) by organic compounds (Pinkernell and von Gunten, 2001), hydrogen peroxide addition (Antoniou and Andersen, 2012) and lowering the ozone dosage during treatment to limit the lifetime of ozone and quench the intermediates of the bromate formation pathway (Soltermann et al., 2017). Treatment units able to remove residual ozone and/or bromo-oxides (e.g. sand filters or biofilters, activated carbon filtration, UV radiation, air stripping) have to be integrated in ozonated saltwater aquaculture systems.

## 6.1 Analytical methods

### 6.1.1 Ozone in seawater

It is difficult to separate ozone and bromine in ozonated saltwater (Jung et al., 2017). Compared to ozone, bromine is more stable but has a lower oxidation potential (ozone=2.07 V and HOBr =1.59 V) in saltwater (Crittenden, 2012). The ozone in seawater can be determined by UV light absorbance at 258 nm where indigo is used to stop the ozonation (von Gunten and Hoigné, 1994). However, the bromine, which is formed during saltwater ozonation, also decolorizes the indigo solution, and produces false positive results in the ozone measurement (Jung et al., 2017). Jung et al (2017) monitored the ozone con-

centration online using a flow injection analysis method and excluded the false positives which were measured with DPD method. However, DPD also reacts with ozone making their approach to subtract the false positive questionable. The DPD method can be used along with glycine, which destroys the ozone in the sample (Palintest). Total residual oxidant (TRO) analysis has been also used (Crecelius, 1979). However, this method cannot distinguish the different oxidants and if bromamines are also present would also contribute to the TRO level (Crecelius, 1979). All these methods are characterized by complexity and require skilled personnel and laboratory equipment and time to obtain reliable results. A real-time method to accurately determine ozone in brominated water without any interference is needed.

### 6.1.2 Optimization of analytical method

To address the issue of bromine interference with the analytical method to determine ozone, it was necessary to mask the effect of brominated species towards indigo. To do that two hypotheses were formulated:

1. Bromite ( $\text{BrO}_2^-$ ), the conjugated base of bromous acid ( $\text{HBrO}_2$ ), wouldn't react with indigo.
2. Ammonia reduces bromate formation during ozonation processes (von Gunten and Hoigné, 1994; Pinkernell and von Gunten, 2001).

The original analysis for ozone determination with the indigo method occurs at pH 2 (Bader and Hoigné, 1981), which is too acetic. The shift of the equilibrium toward  $\text{HOBr}$  (Eq. 7) slows down its oxidation by molecular ozone since only  $\text{OBr}^-$  can be oxidized by ozone (Eq. 5), while the oxidation capacity, the OH radical exposure, remains constant (Pinkernell and von Gunten, 2001). Therefore, the ratio of  $[\bullet\text{OH}]$  and  $[\text{O}_3]$  is decreased when the pH is lowered during ozonation, resulting in reduced bromate formation (Pinkernell and von Gunten, 2001; Antoniou and Andersen, 2012). The  $\text{pK}_a$  of  $\text{HBrO}_2$  is either 6.25 (Massagli et al., 2010) or 3.43 (Faria et al., 1994). By increasing the analysis pH to 5 or 7, higher than the  $\text{pK}_a$  of  $\text{HBrO}_2$ ,  $\text{BrO}_2^-$  would be formed, which was assumed that wouldn't react with indigo. Therefore, the indigo method was modified by replacing the phosphate buffer (pH=2) with the corresponding amount of HCl (0.5 M) to achieve the desired pH.

The pH and alkalinity of the distilled water were adjusted to be the same as in the seawater samples. Then, the samples were subjected to ozonation (5 mg/L) and kinetics experiments were conducted. Results suggested that in-

creasing method's pH from 2 to 5 and 7 respectively did not have any effect on the apparent ozone lifetime of seawater (Figure 22). The initial bromate formation cannot be reduced since it is pH independent.

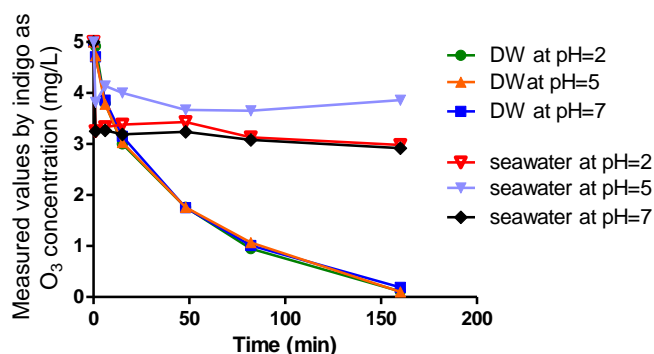

**Figure 22:** Kinetics of ozonated (5 mg O<sub>3</sub>/L) a) distilled water spiked with bromide and b) seawater water spiked with bromide, at different pH.

To further elucidate the effect of ammonia on bromate formation, ozonation experiments with seawater were performed in presence of ammonia to mask HOBr (Eq. 8), which is an important intermediate species to bromate formation. Varying the ammonia concentration had no effect on the ozone decay, which means that disinfection processes remain unaltered (Pinkernell and Von Gunten, 2001). Ammonia concentration higher than 200 µg/L does not further reduce bromate (Pinkernell and Von Gunten, 2001). Ammonia addition does not alter the ozone stability, and, therefore, oxidation and disinfection processes remained unchanged. Although even small ammonia concentrations have a positive effect and it is also a cheap way to minimize bromate formation, this method is not efficient in waters that already contain medium to high levels of ammonia (Pinkernell and von Gunten, 2001).

The colorimetric indigo method (Bader and Hoigné, 1981) was used to determine the ozone concentration. Ammonia addition in the analysis was able to partially mask HOBr and to better determine the ozone dosage (Figure 23). Results suggested that 2.5 min were required to form bromamine in the sample prior to indigo addition. Although the bromine effect is reduced in presence of ammonia, further experiments are needed to reach an optimum solution.

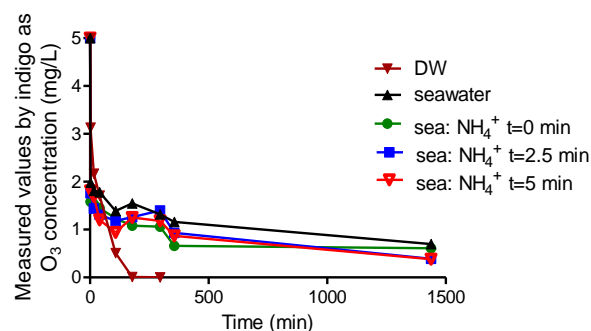

**Figure 23:** Kinetics of ozonated (5 mg O<sub>3</sub>/L) a) distilled water and b) seawater water spiked with NH<sub>4</sub><sup>+</sup>, at different times between sample and indigo addition.

### 6.1.3 HOBr, Br<sup>-</sup> and BrO<sub>3</sub><sup>-</sup> in seawater

In ozonated saltwater samples the quantification of the brominated by-products is crucial. Brominated by-products were determined using reversed-phase HPLC-UV measurements (Heeb et al., 2017). Phenol in acidified conditions has been used to quench hypobromous acid (Pinkernell and von Gunten, 2001) and then was analysed by HPLC. ABTS (2,2-azino-bis(3-ethylbenzothiazoline)-6-sulfonic acid - diammonium salt) has been also used for HOBr analysis by forming a intensively green coloured stable product ABTS<sup>•+</sup> (Pinkernell et al., 2000). Bromide and bromate concentrations were measured by ion chromatography (von Gunten and Hoigné, 1994; Pinkernell and Von Gunten, 2001; Soltermann et al., 2017). Due to the lack of sensitive methods for bromate analysis high bromide concentrations have been used (Pinkernell and von Gunten, 2001).

The complexity of ozonated seawater is still a challenge. Real-time and accurate methods to determine the dissolved ozone in saltwater and brome-oxides in site are needed. Additional experiments to investigate the toxicity of these compounds are also needed to be conducted. Further investigations are required to better understand the seawater chemistry in order to integrate safely ozone in up-running systems.



## 7 Conclusions

This PhD study contributed to the knowledge needed to design a safe continuous ozonation system integrated in constant operated freshwater pilot RASs. The overall water quality was improved whereas the fish welfare remained unaffected by the ozone treatment. The key elements for a safe ozone design were the ozone demand and lifetime which are unique for each facility. Both were determined indirectly by analysing the removal of FDOM contained in RAS water. Fluorescence was a good indicator of organic matter, which accumulated within the system and is highly sensitive to ozone. By analysing specific water samples and determining the ozone demand and kinetics, we were able to provide a new method to predict the required ozone dosage for an up-running system.

Detailed analysis of FDOM revealed the most pronounced fluorescent fractions within the RAS with different reactivity and responsiveness to ozone. This knowledge provided a further insight into the effectiveness of ozone treatment as a method to continuously measure and control organic matter and consequently ozone dosing in a RAS. The fluorescence component with emission peak in the UVA region exhibited the highest removal rate. This could be used to monitor ozone dosage in RAS by manufacturing an online sensor targeting this specific wavelength transition to continually evaluate the ozone treatment and limit the exposure of fish to excessive ozone levels.

The ozone determination in marine RAS water was more complicated. Modification of the analytical method was required since the bromine-oxide formation interfered with the original indigo method (Bader and Hoigné, 1981) causing a false positive measurement. Further experiments are required regarding the bromine-oxide formation upon ozonation and the breakpoint where ozone can be safely used in saltwater RAS to improve water quality without forming the toxic brominated by-products.

To maximize the benefit from such a treatment, the user has to be clear about the purpose of ozonation so as to accurately determine the correct ozone dosages. It is critical that all ozone systems are tested and calibrated in the laboratory and if possible in pilot setups, prior to installation to ensure the true output and concentration.





## 8 Perspectives

### 8.1 Significance of the work

This study provides new methods and tools to better understand the ozone treatment in RAS, the ozone chemistry in both freshwater and saltwater and to utilize the beneficial ozone effects on water quality in RAS. The analysis of a few mL of water sample in the laboratory allowed to determine the ozone demand and the ozone lifetime of the system and also to predict the ozone dosage that was required for a pilot-scale RAS. With this method we can accurately design ozone systems can be designed matching the needs of each individual facility. Fluorescence spectroscopy was a valuable tool to monitor organic matter concentration in the system. The high sensitivity of FDOM to ozone and its selectivity to specific fluorescent components, suggest that fluorescence can be used as an online sensor to control the organic matter and determine indirectly the delivered ozone dosage in the system. The ozonation design was based on the water chemistry, the ozone behaviour in the specific water matrix and not on rule of thumb approximations. This study attempted to clarify some controversial questions regarding ozonation and to offer new technological concepts to make its implementation safe, convincing the aquaculture managers to integrate ozone in RAS.

### 8.2 Suggestions for future research

There is great potential for an online fluorescence sensor for the ozone treatment of RAS water. However, it is rare for RAS to be operated identically, with exactly the same physical, chemical, and microbial water quality. Therefore, it is unlikely that the same ozone dosage would affect two RASs to the same degree. To accurately predict the ozone dosage and kinetics required to best improve water quality in distinct RASs, a database describing the effect of ozone dosages on different RAS water types would be required. This will not only give better predictability of the effect of ozone on a particular type of RAS water, but also will provide information of how best to design the optimal dosage monitoring sensor and ultimately, regulate the ozone dosage in aquaculture systems to appropriate OM content. Further investigation of ozonated seawater systems is needed.

# References

- Angélica Garrido-Pereira, M., Braga, A.L., Rocha, A.F. Da, Sampaio, L.A., Abreu, P.C., 2013. Effect of ultraviolet (UV) radiation on the abundance and respiration rates of probiotic bacteria. *Aquac. Res.* 44, 261–267. <https://doi.org/10.1111/j.1365-2109.2011.03029.x>
- Antoniou, M.G., Andersen, H.R., 2012. Evaluation of pretreatments for inhibiting bromate formation during ozonation. *Environ. Technol. (United Kingdom)* 33, 1747–1753. <https://doi.org/10.1080/09593330.2011.644586>
- Arvin, E., Pedersen, L.F., 2015. Hydrogen peroxide decomposition kinetics in aquaculture water. *Aquac. Eng.* 64, 1–7. <https://doi.org/10.1016/j.aquaeng.2014.12.004>
- Attramadal, K.J.K., Minniti, G., Øie, G., Kjørsvik, E., Østensen, M.A., Bakke, I., Vadstein, O., 2016. Microbial maturation of intake water at different carrying capacities affects microbial control in rearing tanks for marine fish larvae. *Aquaculture* 457, 68–72. <https://doi.org/10.1016/j.aquaculture.2016.02.015>
- Attramadal, K.J.K., Øie, G., Størseth, T.R., Alver, M.O., Vadstein, O., Olsen, Y., 2012. The effects of moderate ozonation or high intensity UV-irradiation on the microbial environment in RAS for marine larvae. *Aquaculture* 330–333, 121–129. <https://doi.org/10.1016/j.aquaculture.2011.11.042>
- Audenaert, W.T.M., Vandierendonck, D., Van Hulle, S.W.H., Nopens, I., 2013. Comparison of ozone and HO induced conversion of effluent organic matter (EfOM) using ozonation and UV/H<sub>2</sub>O<sub>2</sub> treatment. *Water Res.* 47, 2387–2398. <https://doi.org/10.1016/j.watres.2013.02.003>
- Bader, H., Hoigné, J., 1981. Determination of ozone in water by the indigo method. *Water Res.* 15, 449–459. [https://doi.org/10.1016/0043-1354\(81\)90054-3](https://doi.org/10.1016/0043-1354(81)90054-3)
- Bahr, C., Schumacher, J., Ernst, M., Luck, F., Heinzmann, B., Jekel, M., 2007. SUVA as control parameter for the effective ozonation of organic pollutants in secondary effluent, in: *Water Science and Technology*. pp. 267–247. <https://doi.org/10.2166/wst.2007.418>
- Baker, A., 2001. Fluorescence excitation - Emission matrix characterization of some sewage-impacted rivers. *Environ. Sci. Technol.* 35, 948–953. <https://doi.org/10.1021/es000177t>
- Baker, A., Inverarity, R., 2004. Protein-like fluorescence intensity as a possible tool for determining river water quality 2945, 2927–2945. <https://doi.org/10.1002/hyp.5597>
- Baker, A., Spencer, R.G.M., 2004. Characterization of dissolved organic matter from source to sea using fluorescence and absorbance spectroscopy. *Sci. Total Environ.* 333, 217–232. <https://doi.org/10.1016/j.scitotenv.2004.04.013>
- Blancheton, J.P., 2000. Developments in recirculation system for Mediterranean fish species. *Aquac. Eng.* 22, 17–31.
- Blancheton, J.P., Attramadal, K.J.K., Michaud, L., d'Orbcastel, E.R., Vadstein, O., 2013. Insight into bacterial population in aquaculture systems and its implication. *Aquac. Eng.* 53, 30–39. <https://doi.org/10.1016/j.aquaeng.2012.11.009>
- Blancheton, J.P., Canaguier, B., 1995. Bacteria and particulate materials in recirculating seabass (*Dicentrarchus labrax*) production system. *Aquaculture* 133, 215–224.

[https://doi.org/10.1016/0044-8486\(94\)00387-4](https://doi.org/10.1016/0044-8486(94)00387-4)

- Bro, R., 1997. PARAFAC. Tutorial and applications. *Chemom. Intell. Lab. Syst.* 38, 149–171. [https://doi.org/10.1016/S0169-7439\(97\)00032-4](https://doi.org/10.1016/S0169-7439(97)00032-4)
- Bullock, G.L., Summerfelt, S.T., Noble, a C., Weber, a L., Durant, M.D., Hankins, J. a, 1997. Effects of ozone on outbreaks of bacterial gill disease and numbers of heterotrophic bacteria in a trout culture recycle system. Vol. 2, pp. 598-610. 1996. 158, 13–610. [https://doi.org/10.1016/S0044-8486\(97\)00063-X](https://doi.org/10.1016/S0044-8486(97)00063-X)
- Bureau, D.P., Hua, K., 2010. Towards effective nutritional management of waste outputs in aquaculture, with particular reference to salmonid aquaculture operations. *Aquac. Res.* 41, 777–792. <https://doi.org/10.1111/j.1365-2109.2009.02431.x>
- Carstea, E.M., Baker, A., Bierozza, M., Reynolds, D., 2010. Continuous fluorescence excitation-emission matrix monitoring of river organic matter. *Water Res.* 44, 5356–5366. <https://doi.org/10.1016/j.watres.2010.06.036>
- Carstea, E.M., Bridgeman, J., Baker, A., Reynolds, D.M., 2016. Fluorescence spectroscopy for wastewater monitoring: A review. *Water Res.* <https://doi.org/10.1016/j.watres.2016.03.021>
- Cawley, K.M., Butler, K.D., Aiken, G.R., Larsen, L.G., Huntington, T.G., McKnight, D.M., 2012. Identifying fluorescent pulp mill effluent in the Gulf of Maine and its watershed. *Mar. Pollut. Bull.* 64, 1678–1687. <https://doi.org/10.1016/j.marpolbul.2012.05.040>
- Chen, R.F., 1999. In situ fluorescence measurements in coastal waters. *Org. Geochem.* 30, 397–409. [https://doi.org/10.1016/S0146-6380\(99\)00025-X](https://doi.org/10.1016/S0146-6380(99)00025-X)
- Chen, S., Timmons, M.B., Aneshansley, D.J., Bisogni, J.J., 1993. Suspended solids characteristics from recirculating aquacultural systems and design implications. *Aquaculture* 112, 143–155. [https://doi.org/10.1016/0044-8486\(93\)90440-A](https://doi.org/10.1016/0044-8486(93)90440-A)
- Chen, Z., Li, M., Wen, Q., Ren, N., 2017. Evolution of molecular weight and fluorescence of effluent organic matter (EfOM) during oxidation processes revealed by advanced spectrographic and chromatographic tools. *Water Res.* 124, 566–575. <https://doi.org/10.1016/j.watres.2017.08.006>
- Coble, P.G., 1996. Characterization of marine and terrestrial DOM in seawater using excitation-emission matrix spectroscopy. *Mar. Chem.* 51, 325–346. [https://doi.org/10.1016/0304-4203\(95\)00062-3](https://doi.org/10.1016/0304-4203(95)00062-3)
- Coble Paula G., Lead Jamie, Baker Andy, Reynolds Darren M., S.R.G.M., 2014. *Aquatic organic matter fluorescence*. Press, Cambridge University, New York.
- Colberg, P., Lingg, A., 1978. Effect of ozonation on microbial fish pathogens, ammonia, nitrate, nitrite, and BOD in simulated reuse hatchery water. *J. Fish. Res. Board Can* 35, 1290–1296. <https://doi.org/10.1139/f78-203>
- Colt, J., Lamoureux, J., Patterson, R., Rogers, G., 2006. Reporting standards for biofilter performance studies. *Aquac. Eng.* 34, 377–388. <https://doi.org/10.1016/j.aquaeng.2005.09.002>
- Conmy, R.N., Coble, P.G., Del Castillo, C.E., 2004. Calibration and performance of a new in situ multi-channel fluorometer for measurement of colored dissolved organic matter in the ocean. *Cont. Shelf Res.* 24, 431–442. <https://doi.org/10.1016/j.csr.2003.10.010>

- Crecelius, E.A., 1979. Measurements of Oxidants in Ozonized Seawater and Some Biological Reactions. *J. Fish. Res. Board Can.* 36, 1006–1008.
- Cripps, S.J., 1995. Serial particle size fractionation and characterisation of an aquacultural effluent. *Aquaculture* 133, 323–339. [https://doi.org/10.1016/0044-8486\(95\)00021-S](https://doi.org/10.1016/0044-8486(95)00021-S)
- Cripps, S.J., Bergheim, A., 2000. Solids management and removal for intensive land-based aquaculture production systems. *Aquac. Eng.* 22, 33–56. [https://doi.org/10.1016/S0144-8609\(00\)00031-5](https://doi.org/10.1016/S0144-8609(00)00031-5)
- Crittenden J.C., M.W.H. (Firma), 2012. *MWH's Water Treatment: Principle and desig*, 3d edition. ed. Hoboken.
- Cumberland, S., Bridgeman, J., Baker, A., Sterling, M., Ward, D., 2012. Fluorescence spectroscopy as a tool for determining microbial quality in potable water applications. *Environ. Technol.* 33, 687–693. <https://doi.org/10.1080/09593330.2011.588401>
- Dalsgaard, J., Larsen, B.K., Pedersen, P.B., 2015. Nitrogen waste from rainbow trout (*Oncorhynchus mykiss*) with particular focus on urea. *Aquac. Eng.* 65, 2–9. <https://doi.org/10.1016/j.aquaeng.2014.10.004>
- Dalsgaard, J., Pedersen, P.B., 2011. Solid and suspended/dissolved waste (N, P, O) from rainbow trout (*Oncorhynchus mykiss*). *Aquaculture* 313, 92–99. <https://doi.org/10.1016/j.aquaculture.2011.01.037>
- Davidson, J., Good, C., Welsh, C., Summerfelt, S., 2011. The effects of ozone and water exchange rates on water quality and rainbow trout *Oncorhynchus mykiss* performance in replicated water recirculating systems. *Aquac. Eng.* <https://doi.org/10.1016/j.aquaeng.2011.04.001>
- FAO, 2016. 2016 In Brief The State of World Fisheries and Aquaculture, The State of World Fisheries and Aquaculture 2016.
- Faria, R.B., Epstein, I.R., Kustin, K., 1994. Kinetics of Disproportionation and pKa of Bromous Acid. *J. Phys. Chem.* 98, 1363–1367. <https://doi.org/10.1021/j100055a051>
- FEAP Production Report, 2017. FEAP Production Report. Liege, Belgium.
- Fellman, J.B., Hood, E., Amore, D.V.D., Edwards, R.T., White, D., 2009. Seasonal changes in the chemical quality and biodegradability of dissolved organic matter exported in coastal temperate from soils to streams rainforest watersheds. *Biogeochemistry* 95, 277–293. <https://doi.org/10.1007/s10533-009-9336-6>
- Fellman, J.B., Hood, E., Spencer, R.G.M., 2010. Fluorescence spectroscopy opens new windows into dissolved organic matter dynamics in freshwater ecosystems: A review. *Limnol. Oceanogr.* 55, 2452–2462. <https://doi.org/10.4319/lo.2010.55.6.2452>
- Fernandes, P., Pedersen, L.-F., Pedersen, P.B., 2015. Microscreen effects on water quality in replicated recirculating aquaculture systems. *Aquac. Eng.* 65, 17–26. <https://doi.org/10.1016/j.aquaeng.2014.10.007>
- Fernandes, P.M., Pedersen, L.F., Pedersen, P.B., 2014. Daily micro particle distribution of an experimental recirculating aquaculture system-A case study. *Aquac. Eng.* 60, 28–34. <https://doi.org/10.1016/j.aquaeng.2014.03.007>
- Fu, S., Liu, Y., Li, X., Tu, J., Lan, R., Tian, H., 2015. A preliminary stochastic model for managing microorganisms in a recirculating aquaculture system. *Ann. Microbiol.* 65, 1119–1129. <https://doi.org/10.1007/s13213-014-0958-0>

- Gerrity, D., Gamage, S., Jones, D., Korshin, G. V., Lee, Y., Pisarenko, A., Trenholm, R.A., von Gunten, U., Wert, E.C., Snyder, S.A., 2012. Development of surrogate correlation models to predict trace organic contaminant oxidation and microbial inactivation during ozonation. *Water Res.* 46, 6257–6272. <https://doi.org/10.1016/j.watres.2012.08.037>
- Gonçalves, A.A., Gagnon, G.A., 2011. Ozone application in recirculating aquaculture system: An overview. *Ozone Sci. Eng.* 33, 345–367. <https://doi.org/10.1080/01919512.2011.604595>
- Good, C., Davidson, J., Welsh, C., Snekvik, K., Summerfelt, S., 2011a. The effects of ozonation on performance, health and welfare of rainbow trout *Oncorhynchus mykiss* in low-exchange water recirculation aquaculture systems. *Aquac. Eng.* 44, 97–102. <https://doi.org/10.1016/j.aquaeng.2011.04.003>
- Grady, C.P.L., Daigger, G.T.N., Love, C. Filipe., C.D.M, 2011. *Biological wastewater treatment – Theory and applications.*, Third edit. ed. IWA Publishing, London, UK.
- Grguric, G., Trefry, J.H., Keaffaber, J.J., 1994. Ozonation products of bromine and chlorine in seawater aquaria. *Water Res.* [https://doi.org/10.1016/0043-1354\(94\)90194-5](https://doi.org/10.1016/0043-1354(94)90194-5)
- Gueguen, C., Cuss, C.W., Cassels, C.J., Carmack, E.C., 2014. Absorption and fluorescence of dissolved organic matter in the waters of the Canadian Arctic Archipelago, Baffin Bay, and the Labrador Sea. *J. Geophys. Res. Ocean.* 119, 2034–2047. <https://doi.org/10.1002/2013JC009173>.Received
- Guerdat, T.C., Losordo, T.M., Classen, J.J., Osborne, J.A., DeLong, D., 2011. Evaluating the effects of organic carbon on biological filtration performance in a large scale recirculating aquaculture system. *Aquac. Eng.* 44, 10–18. <https://doi.org/10.1016/j.aquaeng.2010.10.002>
- Hagopian, D.S., Riley, J.G., 1998. A closer look at the bacteriology of nitrification. *Aquac. Eng.* 18, 223–244. [https://doi.org/10.1016/S0144-8609\(98\)00032-6](https://doi.org/10.1016/S0144-8609(98)00032-6)
- Hambly, A. C., Henderson, R.K., Baker, a., Stuetz, R.M., Khan, S.J., 2012. Cross-connection detection in Australian dual reticulation systems by monitoring inherent fluorescent organic matter. *Environ. Technol. Rev.* 2515, 1–14. <https://doi.org/10.1080/09593330.2012.696724>
- Hambly, A., Henderson, R.K., Baker, A., Stuetz, R.M., Khan, S.J., 2010. Probabilistic analysis of fluorescence signals for monitoring dual reticulation water recycling schemes. *Water Sci. Technol.* 62, 2059–2065. <https://doi.org/10.2166/wst.2010.504>
- Hambly, A.C., Arvin, E., Pedersen, L.F., Pedersen, P.B., Seredyńska-Sobecka, B., Stedmon, C.A., 2015. Characterising organic matter in recirculating aquaculture systems with fluorescence EEM spectroscopy. *Water Res.* 83, 112–120. <https://doi.org/10.1016/j.watres.2015.06.037>
- Hammes, F., Salhi, E., Köster, O., Kaiser, H.P., Egli, T., von Gunten, U., 2006. Mechanistic and kinetic evaluation of organic disinfection by-product and assimilable organic carbon (AOC) formation during the ozonation of drinking water. *Water Res.* 40, 2275–2286. <https://doi.org/10.1016/j.watres.2006.04.029>
- Hansen, K.M.S., Andersen, H.R., Ledin, A., 2010. Ozonation of estrogenic chemicals in biologically treated sewage. *Water Sci. Technol.* 649–657. <https://doi.org/10.2166/wst.2010.919>

- Hansen, K.M.S., Spiliotopoulou, A., Cheema, W.A., Andersen, H.R., 2016a. Effect of ozonation of swimming pool water on formation of volatile disinfection by-products - A laboratory study. *Chem. Eng. J.* <https://doi.org/10.1016/j.cej.2015.12.052>
- Hansen, K.M.S., Spiliotopoulou, A., Chhetri, R.K., Escolà Casas, M., Bester, K., Andersen, H.R., 2016b. Ozonation for source treatment of pharmaceuticals in hospital wastewater - Ozone lifetime and required ozone dose. *Chem. Eng. J.* 507–514. <https://doi.org/10.1016/j.cej.2016.01.027>
- Heeb, M.B., Criquet, J., Zimmermann-Steffens, S.G., Von Gunten, U., 2014. Oxidative treatment of bromide-containing waters: Formation of bromine and its reactions with inorganic and organic compounds - A critical review. *Water Res.* <https://doi.org/10.1016/j.watres.2013.08.030>
- Heeb, M.B., Kristiana, I., Trogolo, D., Arey, J.S., von Gunten, U., 2017. Formation and reactivity of inorganic and organic chloramines and bromamines during oxidative water treatment. *Water Res.* 110, 91–101. <https://doi.org/10.1016/j.watres.2016.11.065>
- Henderson, R.K., Baker, A., Murphy, K.R., Hambly, A., Stuetz, R.M., Khan, S.J., 2009. Fluorescence as a potential monitoring tool for recycled water systems: A review. *Water Res.* <https://doi.org/10.1016/j.watres.2008.11.027>
- Hess-Erga, O.K., Attramadal, K.J.K., Vadstein, O., 2008. Biotic and abiotic particles protect marine heterotrophic bacteria during UV and ozone disinfection. *Aquat. Biol.* 4, 147–154. <https://doi.org/10.3354/ab00105>
- Hiroaki Matsuda a, Youki Ose b, Takahiko Sato c, H.N.H.K. c and K.S., 1992. Mutagenicity from ozonation of humic substances 118, 521–529.
- Hohreiter, D.W., Rigg, D.K., 2001. Derivation of ambient water quality criteria for formaldehyde. *Chemosphere* 45, 471–486. [https://doi.org/10.1016/S0045-6535\(01\)00061-3](https://doi.org/10.1016/S0045-6535(01)00061-3)
- Hudson, Naomi; Baker, Andy; Reynolds, D., 2007. Fluorescence analysis of dissolved organic matter in natural, waste and polluted waters—a review. *River Res. Appl.* 23, 631–649. <https://doi.org/10.1002/rra>
- Hudson, N., Baker, A., Ward, D., Reynolds, D.M., Brunson, C., Carliell-Marquet, C., Browning, S., 2008. Can fluorescence spectrometry be used as a surrogate for the Biochemical Oxygen Demand (BOD) test in water quality assessment? An example from South West England. *Sci. Total Environ.* 391, 149–158. <https://doi.org/10.1016/j.scitotenv.2007.10.054>
- Jørgensen, L., Stedmon, C.A., Kragh, T., Markager, S., Middelboe, M., Søndergaard, M., 2011. Global trends in the fluorescence characteristics and distribution of marine dissolved organic matter. *Mar. Chem.* 126, 139–148. <https://doi.org/10.1016/j.marchem.2011.05.002>
- Jung, Y., Hong, E., Kwon, M., Kang, J.W., 2017. A kinetic study of ozone decay and bromine formation in saltwater ozonation: Effect of O<sub>3</sub> dose, salinity, pH, and temperature. *Chem. Eng. J.* 312, 30–38. <https://doi.org/10.1016/j.cej.2016.11.113>
- Korshin, G. V, Kumke, M.U., Li, C.-W., Frimmel, F.H., 1999. Influence of chlorination on chromophores and fluorophores in humic substances. *Environ. Sci. Technol.* 33, 1207–1212.

- Kroupova, H., Machova, J., Svobodova, Z., 2005. Nitrite influence on fish: A review. *Vet. Med. (Praha)*. 50, 461–471.
- Lambert, T., Teodoru, C.R., Nyoni, F.C., Bouillon, S., Darchambeau, F., Massicotte, P., Borges, A. V., 2016. Along-stream transport and transformation of dissolved organic matter in a large tropical river. *Biogeosciences* 13, 2727–2741. <https://doi.org/10.5194/bg-13-2727-2016>
- Langlais, B., Reckhow, D.A., Brink, D.R., 1991. *Ozone in Water Treatment: Application and Engineering*. Denver, CO.
- Lekang, O.I., 2007. *Aquaculture Engineering*, Aquaculture Engineering. Blackwell Publishing Ltd, Oxford, UK. <https://doi.org/10.1002/9780470995945>
- Leonard, N., Blancheton, J.P., Guiraud, J.P., 2000. Populations of heterotrophic bacteria in an experimental recirculating aquaculture system. *Aquac. Eng.* 22, 109–120. [https://doi.org/10.1016/S0144-8609\(00\)00035-2](https://doi.org/10.1016/S0144-8609(00)00035-2)
- Li, W.-T., Majewsky, M., Abbt-Braun, G., Horn, H., Jin, J., Li, Q., Zhou, Q., Li, A.-M., 2016. Application of portable online LED UV fluorescence sensor to predict the degradation of dissolved organic matter and trace organic contaminants during ozonation. *Water Res.* <https://doi.org/10.1016/j.watres.2016.05.090>
- Li, X., Blancheton, J.-P., Liu, Y., Triplet, S., Michaud, L., 2014. Effect of oxidation–reduction potential on performance of European sea bass (*Dicentrarchus labrax*) in recirculating aquaculture systems. *Aquac. Int.* 22, 1263–1282. <https://doi.org/10.1007/s10499-013-9745-3>
- Liltved, H., Hektoen, H., Efraimsen, H., 1995. Inactivation of bacterial and viral fish pathogens by ozonation or UV irradiation in water of different salinity. *Aquac. Eng.* 14, 107–122. [https://doi.org/10.1016/0144-8609\(94\)P4430-J](https://doi.org/10.1016/0144-8609(94)P4430-J)
- Liu, C., Li, P., Tang, X., Korshin, G. V., 2016. Ozonation effects on emerging micropollutants and effluent organic matter in wastewater: characterization using changes of three-dimensional HP-SEC and EEM fluorescence data. *Environ. Sci. Pollut. Res.* 23, 20567–20579. <https://doi.org/10.1007/s11356-016-7287-8>
- Liu, C., Tang, X., Kim, J., Korshin, G. V., 2015. Formation of aldehydes and carboxylic acids in ozonated surface water and wastewater: A clear relationship with fluorescence changes. *Chemosphere*. <https://doi.org/10.1016/j.chemosphere.2014.12.054>
- Logue, J.B., Stedmon, C.A., Kellerman, A.M., Nielsen, N.J., Andersson, A.F., Laudon, H., Lindström, E.S., Kritzberg, E.S., 2016. Experimental insights into the importance of aquatic bacterial community composition to the degradation of dissolved organic matter. *ISME J.* 10, 533–545. <https://doi.org/10.1038/ismej.2015.131>
- Magazinovic, R.S., Nicholson, B.C., Mulcahy, D.E., Davey, D.E., 2004. Bromide levels in natural waters: Its relationship to levels of both chloride and total dissolved solids and the implications for water treatment. *Chemosphere* 57, 329–335. <https://doi.org/10.1016/j.chemosphere.2004.04.056>
- Mangalgi, K.P., Timko, S.A., Gonsior, M., Blaney, L., 2017. PARAFAC Modeling of Irradiation- and Oxidation-Induced Changes in Fluorescent Dissolved Organic Matter Extracted from Poultry Litter. *Environ. Sci. Technol.* 51, 8036–8047. <https://doi.org/10.1021/acs.est.6b06589>

- Martins, C.I.M., Eding, E.H., Verdegem, M.C.J., Heinsbroek, L.T.N., Schneider, O., Blancheton, J.P., d'Orbcastel, E.R., Verreth, J.A.J., 2010. New developments in recirculating aquaculture systems in Europe: A perspective on environmental sustainability. *Aquac. Eng.* 43, 83–93. <https://doi.org/10.1016/j.aquaeng.2010.09.002>
- Massagli, A., Indelli, A., Pergola, F., 2010. of the Decomposition. *Inorganica Chim. Acta* 2010, 593–596.
- Masters, 2004. A Review of Methods for Detoxification and Neutralization of Formalin in Water 66, 325–333.
- Moestrup, Ø., Hansen, G., Daugbjerg, N., Lundholm, N., Overton, J., Vestergård, M., Steinfeldt, S.J., Calado, A.J., Hansen, P.J., 2014. The dinoflagellates *Pfiesteria shumwayae* and *Luciella masanensis* cause fish kills in recirculation fish farms in Denmark. *Harmful Algae* 32, 33–39. <https://doi.org/10.1016/j.hal.2013.12.002>
- Muller, P.Y., Milton, M.N., 2012. The determination and interpretation of the therapeutic index in drug development. *Nat. Rev. Drug Discov.* 11, 751–761. <https://doi.org/10.1038/nrd3801>
- Murphy, K., Bro, R., Stedmon, C., 2014. Chemometric analysis of organic matter fluorescence, in: Paula Coble, Jamie Lead, Andy Baker, Darren Reynolds, R.G.M.S. (Ed.), *Aquatic Organic Matter Fluorescence*. Cambridge University Press, pp. 339–375. <https://doi.org/10.1017/CBO9781139045452.016>
- Murphy, K.R., Hambly, A., Singh, S., Henderson, R.K., Baker, A., Stuetz, R., Khan, S.J., 2011. Organic matter fluorescence in municipal water recycling schemes: Toward a unified PARAFAC model. *Environ. Sci. Technol.* 45, 2909–2916. <https://doi.org/10.1021/es103015e>
- Murphy, K.R., Stedmon, C.A., Wenig, P., Bro, R., 2014. OpenFluor– an online spectral library of auto-fluorescence by organic compounds in the environment. *Anal. Methods* 6, 658–661. <https://doi.org/10.1039/C3AY41935E>
- Nam, T.K., Timmons, M.B., Montemagno, C.D., Tsukuda, S.M., 2000. Biofilm characteristics as affected by sand size and location in fluidized bed vessels. *Aquac. Eng.* 22, 213–224. [https://doi.org/10.1016/S0144-8609\(00\)00040-6](https://doi.org/10.1016/S0144-8609(00)00040-6)
- Nijhof, M., 1994. Theoretical effects of feed composition, feed conversion and feed spillage on waste discharge in fish culture. *J. Appl. Ichthyol.* 10, 274–283. <https://doi.org/10.1111/j.1439-0426.1994.tb00167.x>
- Noble, A.C., Summerfelt, S.T., 1996. DISEASES ENCOUNTERED IN RAINBOW TROUT CULTURED IN RECIRCULATING SYSTEMS. *Pergamon Annu. Rev. Fish Dis.* 6, 65–92.
- Osburn, C.L., Wigdahl, C.R., Fritz, S.C., Saros, J.E., 2011. Dissolved organic matter composition and photoreactivity in prairie lakes of the U.S. Great Plains. *Limnol. Oceanogr.* 56, 2371–2390. <https://doi.org/10.4319/lo.2011.56.6.2371>
- Owsley, D.E., 1991. Ozone for disinfecting hatchery rearing water, in: RJ;, C.J. (Ed.), *Fisheries Bioengineering Symposium: American Fisheries Society Symposium 10*. American Fisheries Society, Bethesda, MD, pp. 417–420.
- Pedersen, L.F., Meinelt, T., Straus, D.L., 2013. Peracetic acid degradation in freshwater aquaculture systems and possible practical implications. *Aquac. Eng.* 53, 65–71. <https://doi.org/10.1016/j.aquaeng.2012.11.011>



- Pedersen, L.F., Pedersen, P.B., 2012. Hydrogen peroxide application to a commercial recirculating aquaculture system. *Aquac. Eng.* 46, 40–46. <https://doi.org/10.1016/j.aquaeng.2011.11.001>
- Pedersen, L.F., Pedersen, P.B., Nielsen, J.L., Nielsen, P.H., 2010. Long term/low dose formalin exposure to small-scale recirculation aquaculture systems. *Aquac. Eng.* 42, 1–7. <https://doi.org/10.1016/j.aquaeng.2009.08.002>
- Pedersen, L.F., Pedersen, P.B., Sortkjær, O., 2007. Temperature-dependent and surface specific formaldehyde degradation in submerged biofilters. *Aquac. Eng.* 36, 127–136. <https://doi.org/10.1016/j.aquaeng.2006.09.004>
- Pedersen, L.F., Suhr, K.I., Dalsgaard, J., Pedersen, P.B., Arvin, E., 2012. Effects of feed loading on nitrogen balances and fish performance in replicated recirculating aquaculture systems. *Aquaculture* 338–341, 237–245. <https://doi.org/10.1016/j.aquaculture.2012.01.035>
- Pedersen, P.B., von Ahnen, M., Fernandes, P., Naas, C., Pedersen, L.F., Dalsgaard, J., 2017. Particle surface area and bacterial activity in recirculating aquaculture systems. *Aquac. Eng.* 78, 18–23. <https://doi.org/10.1016/j.aquaeng.2017.04.005>
- Peleato, N.M., Sidhu, B.S., Legge, R.L., Andrews, R.C., 2017. Investigation of ozone and peroxone impacts on natural organic matter character and biofiltration performance using fluorescence spectroscopy. *Chemosphere* 172, 225–233. <https://doi.org/10.1016/j.chemosphere.2016.12.118>
- Pinkernell, U., Nowack, B., Gallard, H., Von Gunten, U., 2000. Methods for the photometric determination of reactive bromine and chlorine species with ABTS. *Water Res.* 34, 4343–4350. [https://doi.org/10.1016/S0043-1354\(00\)00216-5](https://doi.org/10.1016/S0043-1354(00)00216-5)
- Pinkernell, U., Von Gunten, U., 2001. Bromate minimization during ozonation: Mechanistic considerations. *Environ. Sci. Technol.* 35, 2525–2531. <https://doi.org/10.1021/es001502f>
- Powell, A., Chingombe, P., Lupatsch, I., Shields, R.J., Lloyd, R., 2015. The effect of ozone on water quality and survival of turbot (*Psetta maxima*) maintained in a recirculating aquaculture system. *Aquac. Eng.* <https://doi.org/10.1016/j.aquaeng.2014.11.005>
- Powell, A., Scolding, J.W.S., 2016. Direct application of ozone in aquaculture systems 1–15. <https://doi.org/10.1111/raq.12169>
- Reeslev, M., Nielsen, J.C., Rogers, L., Brisson, M., Ashley, K., Lesage, J., Dean, S.W., 2011. Assessment of the Bacterial Contamination and Remediation Efficacy After Flooding Using Fluorometric Detection. *J. ASTM Int.* 8, 103482. <https://doi.org/10.1520/JAI103482>
- Reynolds, D.M., Ahmad, S.R., 1997. Rapid and direct determination of wastewater BOD values using a fluorescence technique. *Water Res.* 31, 2012–2018. [https://doi.org/10.1016/S0043-1354\(97\)00015-8](https://doi.org/10.1016/S0043-1354(97)00015-8)
- Rice, R.G., Robson, C.M., Miller, G.W., Hill, A.G., 1981. Uses of ozone in drinking water treatment. *Am. Water Work. Assoc. J.* 73, 1–44.
- Riopel, R., Caron, F., Siemann, S., 2014. Fluorescence Characterization of Natural Organic Matter at a Northern Ontario Wastewater Treatment Plant. *Water, Air, Soil Pollut.* 225, 2126. <https://doi.org/10.1007/s11270-014-2126-3>

- Robin K. King , Jr. George J. Flick , Stephen A. Smith, M.D.P., Coale, G.D.B.& J.C.W., 2006. Use of Additional Substrate to Enhance Growth Performance of Milkfish , *Chanos chanos* ( Forsskal ) in Inland Saline Groundwater Ponds. *J. Appl. Aquac.* 18, 79–88. <https://doi.org/10.1300/J028v18n01>
- Rojas-Tirado, P., Pedersen, P.B., Pedersen, L.F., 2017. Bacterial activity dynamics in the water phase during start-up of recirculating aquaculture systems. *Aquac. Eng.* 78, 24–31. <https://doi.org/10.1016/j.aquaeng.2016.09.004>
- Rojas-Tirado, P., Pedersen, P.B., Vadstein, O., Pedersen, L.F., 2018. Changes in microbial water quality in RAS following altered feed loading. *Aquac. Eng.* 81, 80–88. <https://doi.org/10.1016/j.aquaeng.2018.03.002>
- Rurangwa, E., Verdegem, M.C.J., 2015. Microorganisms in recirculating aquaculture systems and their management. *Rev. Aquac.* 7, 117–130. <https://doi.org/10.1111/raq.12057>
- Schwartz, M. F., G. L. Bullock, J. A. Hankins, S. T. Summerfelt, and J.A.M., 2000. Effects of selected chemo-therapeutants on nitrification in fluidized-sand biofilters for coldwater fish production. *Int. J. Recirc. Aquac.* 1, 61–81.
- Sharrer, M.J., Summerfelt, S.T., 2007. Ozonation followed by ultraviolet irradiation provides effective bacteria inactivation in a freshwater recirculating system. *Aquac. Eng.* 37, 180–191. <https://doi.org/10.1016/j.aquaeng.2007.05.001>
- Sharrer, M.J., Summerfelt, S.T., Bullock, G.L., Gleason, L.E., Taeuber, J., 2005. Inactivation of bacteria using ultraviolet irradiation in a recirculating salmonid culture system. *Aquac. Eng.* 33, 135–149. <https://doi.org/10.1016/j.aquaeng.2004.12.001>
- Soltermann, F., Abegglen, C., Tschui, M., Stahel, S., Gunten, U. Von, 2017. Options and limitations for bromate control during ozonation of wastewater. *Water Res.* 116, 76–85. <https://doi.org/10.1016/j.watres.2017.02.026>
- Sorensen, J.P.R., Baker, A., Cumberland, S.A., Lapworth, D.J., MacDonald, A.M., Pedley, S., Taylor, R.G., Ward, J.S.T., 2018. Real-time detection of faecally contaminated drinking water with tryptophan-like fluorescence: defining threshold values. *Sci. Total Environ.* 622–623, 1250–1257. <https://doi.org/10.1016/j.scitotenv.2017.11.162>
- Srinivas, T., 2008. *Environmental Biotechnology*. New Age International Publisher, New Delhi.
- Stedmon, Colin; Cory, R.M., 2014. Biological origins and fate of fluorescent dissolved organic matter, in: *Aquatic Organic Matter Fluorescence*. Cambridge University Press.
- Stedmon, C.A., Markager, S., Bro, R., 2003. Tracing dissolved organic matter in aquatic environments using a new approach to fluorescence spectroscopy. *Mar. Chem.* 82, 239–254. [https://doi.org/10.1016/S0304-4203\(03\)00072-0](https://doi.org/10.1016/S0304-4203(03)00072-0)
- Stedmon, C.A., Thomas, D.N., Papadimitriou, S., Granskog, M.A., Dieckmann, G.S., 2011. Using fluorescence to characterize dissolved organic matter in Antarctic sea ice brines. *J. Geophys. Res. Biogeosciences* 116, 1–9. <https://doi.org/10.1029/2011JG001716>
- Summerfelt, S.T., 2003. Ozonation and UV irradiation. *Aquac. Eng.* 28, 36.
- Summerfelt, S.T., Hankins, J.A., Weber, A.L., Durant, M.D., Virginia, W., 1997. Effects

of ozone on microscreen filtration and water quality in a recirculating rainbow trout culture system 158, 1–12.

- Summerfelt, S.T., Hochheimer, J.N., 1997. Review of Ozone Processes and Applications as an Oxidizing Agent in Aquaculture. *Progress. Fish-Culturist* 59, 94–105. [https://doi.org/10.1577/1548-8640\(1997\)059<0094:ROOPAA>2.3.CO;2](https://doi.org/10.1577/1548-8640(1997)059<0094:ROOPAA>2.3.CO;2)
- Summerfelt, S.T., Sharrer, M.J., Tsukuda, S.M., Gearheart, M., 2009. Process requirements for achieving full-flow disinfection of recirculating water using ozonation and UV irradiation. *Aquac. Eng.* <https://doi.org/10.1016/j.aquaeng.2008.10.002>
- Svobodová, Z., Máchová, J., Poleszczuk, G., Hůda, J., Hamáčková, J., Kroupová, H., 2005. Nitrite poisoning of fish in aquaculture facilities with water-recirculating systems. *Acta Vet. Brno* 74, 129–137. <https://doi.org/10.2754/avb200574010129>
- Tango, M.S., Gagnon, G.A., 2003. Impact of ozonation on water quality in marine recirculation systems. *Aquac. Eng.* 29, 125–137. [https://doi.org/10.1016/S0144-8609\(03\)00061-X](https://doi.org/10.1016/S0144-8609(03)00061-X)
- Timmons, M.B., Ebeling, J.M., Wheaton, F.W., Summerfelt, S.T., Vinci, B.J., 2002. *Recirculating Aquaculture Systems*, 2nd Ed. ed. Cayuga Aqua Ventures, Ithaca, NY, USA.
- Tipping, J.M., 1988. Ozone Control of Ceratomyxosis: Survival and Growth Benefits to Steelhead and Cutthroat Trout. *Progress. Fish-Culturist* 50, 202–210.
- Tsolaki, E., Diamadopoulos, E., 2010. Technologies for ballast water treatment: A review. *J. Chem. Technol. Biotechnol.* 85, 19–32. <https://doi.org/10.1002/jctb.2276>
- Van Nevel, S., Koetzsch, S., Proctor, C.R., Besmer, M.D., Prest, E.I., Vrouwenvelder, J.S., Knezev, A., Boon, N., Hammes, F., 2017. Flow cytometric bacterial cell counts challenge conventional heterotrophic plate counts for routine microbiological drinking water monitoring. *Water Res.* 113, 191–206. <https://doi.org/10.1016/j.watres.2017.01.065>
- Verdegem, M.C.J., 2013. Nutrient discharge from aquaculture operations in function of system design and production environment. *Rev. Aquac.* 5, 158–171. <https://doi.org/10.1111/raq.12011>
- Verner-Jeffreys, D. and T.N., 2015. SARF 100 -Review of freshwater treatments used in the Scottish freshwater rainbow trout aquaculture industry.
- Von Gunten, U., 2003. Ozonation of drinking water: Part I. Oxidation kinetics and product formation. *Water Res.* 37, 1443–1467. [https://doi.org/10.1016/S0043-1354\(02\)00457-8](https://doi.org/10.1016/S0043-1354(02)00457-8)
- Von Gunten, U., Hoigné, J., 1994. Bromate Formation during Ozonation of Bromide-Containing Waters: Interaction of Ozone and Hydroxyl Radical Reactions. *Environ. Sci. Technol.* 28, 1234–1242. <https://doi.org/10.1021/es00056a009>
- Von Sonntag, Clemens; Von Gunten, U., 2012. *Chemistry of ozone water and wastewater treatment*, 1st ed. IWA Publishing, London.
- Wert, E.C., Neemann, J.J., Rexing, D.J., Zegers, R.E., 2008. Biofiltration for removal of BOM and residual ammonia following control of bromate formation. *Water Res.* 42, 372–378. <https://doi.org/10.1016/j.watres.2007.07.028>
- Williams, C.J., Frost, P.C., Xenopoulos, M.A., Williams, J., 2016. Beyond best

management practices : pelagic biogeochemical dynamics in urban stormwater ponds  
Published by : Ecological Society of America Linked references are available on  
JSTOR for this article : Your use of the JSTOR archive indicates your acceptance o  
23, 1384–1395.

- Wold, P.A., Holan, A.B., Øie, G., Attramadal, K., Bakke, I., Vadstein, O., Leiknes, T.O., 2014. Effects of membrane filtration on bacterial number and microbial diversity in marine recirculating aquaculture system (RAS) for Atlantic cod (*Gadus morhua* L.) production. *Aquaculture* 422–423, 69–77. <https://doi.org/10.1016/j.aquaculture.2013.11.019>
- Wooster, G., Martinez, C., Bowser, P., O'Hara, D., 2005. Human Health Risks Associated with Formalin Treatments Used in Aquaculture: Initial Study. *N. Am. J. Aquac.* 67, 111–113. <https://doi.org/10.1577/A04-026.1>
- Yamashita, Y., Boyer, J.N., Jaffé, R., 2013. Evaluating the distribution of terrestrial dissolved organic matter in a complex coastal ecosystem using fluorescence spectroscopy. *Cont. Shelf Res.* 66, 136–144. <https://doi.org/10.1016/j.csr.2013.06.010>
- Yamashita, Y., Maie, N., Briceño, H., Jaffé, R., 2010. Optical characterization of dissolved organic matter in tropical rivers of the Guayana Shield, Venezuela. *J. Geophys. Res. Biogeosciences* 115. <https://doi.org/10.1029/2009JG000987>
- Yamin, G., Borisover, M., Cohen, E., van Rijn, J., 2017a. Accumulation of humic-like and proteinaceous dissolved organic matter in zero-discharge aquaculture systems as revealed by fluorescence EEM spectroscopy. *Water Res.* 108, 412–421. <https://doi.org/10.1016/j.watres.2016.11.028>
- Yamin, G., Falk, R., Avtalion, R.R., Shoshana, N., Ofek, T., Smirnov, R., Rubenstein, G., van Rijn, J., 2017b. The protective effect of humic-rich substances on atypical *Aeromonas salmonicida* subsp. *salmonicida* infection in common carp (*Cyprinus carpio* L.). *J. Fish Dis.* 40, 1783–1790. <https://doi.org/10.1111/jfd.12645>
- Yamin, G., Zilberg, D., Levy, G., van Rijn, J., 2017. The protective effect of humic-rich substances from monogenean parasites infecting the guppy (*Poecilia reticulata*). *Aquaculture* 479, 487–489. <https://doi.org/10.1016/j.aquaculture.2017.06.022>
- Yu, H., Liang, H., Qu, F., Han, Z.S., Shao, S., Chang, H., Li, G., 2015. Impact of dataset diversity on accuracy and sensitivity of parallel factor analysis model of dissolved organic matter fluorescence excitation-emission matrix. *Sci. Rep.* 5, 1–11. <https://doi.org/10.1038/srep10207>

# Papers

The following papers are included in the thesis:

- I **Aikaterini Spiliotopoulou**, Richard Martin, Lars-Flemming Pedersen & Henrik R. Andersen. Use of fluorescence spectroscopy to control dissolved ozone in recirculating aquaculture systems. *Water research*, 111 (2017), 357-365.
- II **Aikaterini Spiliotopoulou**, Paula Rojas-Tirado, Ravi K. Chhetri, Kamilla M.S. Kaarsholm, Richard Martin, Per B. Pedersen, Lars-Flemming Pedersen & Henrik R. Andersen. Ozonation control and effects of ozone on water quality in recirculating aquaculture systems. *Water research*, 133C (2018), 289-298.
- V **Aikaterini Spiliotopoulou**, Henrik R. Andersen, Lars-Flemming Pedersen, Colin A. Stedmon & Adam Hambly. Resolving the reaction kinetics of ozone and organic matter in recirculating aquaculture systems using fluorescence EEM spectroscopy. *Manuscript*.
- VI Paula Rojas-Tirado, **Aikaterini Spiliotopoulou**, Richard Martin, Henrik R. Andersen, Per B. Pedersen & Lars-Flemming Pedersen. Ozone effects on microbial water quality in pilot-scale recirculating aquaculture systems. *Manuscript*.

The Department of Environmental Engineering (DTU Environment) conducts science-based engineering research within five sections:  
Air, Land & Water Resources, Environmental Fate & Effect of Chemicals, Residual Resource Engineering, Urban Water Systems and Water Technologies.

The department dates back to 1865, when Ludvig August Colding, the founder of the department, gave the first lecture on sanitary engineering as response to the cholera epidemics in Copenhagen in the late 1800s.

**DTU Environment**

Department of Environmental Engineering  
Technical University of Denmark

Bygningstorvet, Bygning 115  
2800 Kgs. Lyngby, Denmark  
Tlf. 45 25 16 00  
Fax 45 93 28 50

[www.env.dtu.dk](http://www.env.dtu.dk)