



## Rotor angle stability support from ReGen plants in power systems

Altin, Müfit; Iov, Florin

*Publication date:*  
2018

*Document Version*  
Publisher's PDF, also known as Version of record

[Link back to DTU Orbit](#)

*Citation (APA):*  
Altin, M., & Iov, F. (2018). Rotor angle stability support from ReGen plants in power systems.

---

### General rights

Copyright and moral rights for the publications made accessible in the public portal are retained by the authors and/or other copyright owners and it is a condition of accessing publications that users recognise and abide by the legal requirements associated with these rights.

- Users may download and print one copy of any publication from the public portal for the purpose of private study or research.
- You may not further distribute the material or use it for any profit-making activity or commercial gain
- You may freely distribute the URL identifying the publication in the public portal

If you believe that this document breaches copyright please contact us providing details, and we will remove access to the work immediately and investigate your claim.

# Rotor angle stability support from ReGen plants in power systems

Agreement no.: PSO ForskEl 12347  
Project Name: Ancillary Services from Renewable Power Plants  
Acronym: RePlan  
Duration: 2015 - 2018  
Co-ordinator: DTU Wind Energy

## Document information

Document name:	Rotor angle stability support from ReGen plants in power systems
Document number:	D4
Lead Author	Müfit Altin
Contributors:	Florin Iov
Document type:	Delivarable D4
Date:	29.05.2018
WP:	4

## 1 Contents

Preface.....	5
2 Scope of document.....	1
3 Identification of Rotor Angle Stability Challenges.....	1
3.1 Background.....	1
3.2 Objectives in WP4.....	2
4 Active and Reactive Power Control Capabilities of ReGen Plants.....	4
4.1 Technical Capabilities of Wind and Photovoltaic Power Plants.....	4
4.1.1 Reactive Power Setpoint Processing Functionality.....	4
4.1.2 Reactive Power Provision Functionality.....	4
4.2 Technical Capabilities of ReGen Plants applied in RePlan.....	5
5 System Models for Rotor Angle Support.....	6
5.1 Generic 12-bus Model.....	6
5.1.1 Assumptions and limitations.....	6
5.1.2 Model characterization.....	6
5.2 ReGen Penetration Scenarios.....	7
5.3 ReGen Plant Models.....	8
5.3.1 General assumptions and limitations.....	8
5.3.2 Model Characterization.....	8
6 Small Signal Stability Analysis.....	9
6.1 Observability and Controllability Analysis.....	9
6.2 Results and Analysis.....	11
6.2.1 Mode Shapes.....	11
6.2.2 Participation Factors.....	12
6.2.3 Observability of Mode Shapes.....	14
6.2.4 Controllability of Mode Shapes.....	17
7 Considerations on RAS support implementation.....	18
7.1 RAS Support Functionality.....	18
7.2 Control Architectures.....	19
7.3 ICT impact on RAS Support schemes.....	20
8 Conclusions and Recommendations.....	20



---

References .....	21
Appendix.....	23

## **Preface**

This report is a deliverable in WP4 in the project “Ancillary services from Renewable power Plants” (RePlan). RePlan is funded as POS project 2015 no. 12347 by the Danish PSO-programme ForskEL, which is administered by Energinet.DK. RePlan is carried out in collaboration between DTU Wind Energy, DTU Elektro, Aalborg University Energy Technology, Aalborg University Wireless Communication Networks and Vestas Wind System A/S. DTU Wind Energy is manager of the project.

## 2 Scope of document

This deliverable report is summarizing the results of work package 4 (Rotor angle stability support from ReGen plants), including the related models, methodologies, and study cases. The objective of this work package is to identify rotor angle stability challenges related to the large penetration of ReGen plants into power systems and to investigate the suitability for a coordinated rotor angle stability support from ReGen plants.

## 3 Identification of Rotor Angle Stability Challenges

This chapter presents the Rotor Angle Stability challenges in power systems with large penetration of ReGen, being related to angle deviations in power systems due to the replacement of conventional power plants. Related considerations regarding the increasing penetration of wind and solar (PV) power in power systems are made. Technical specifications regarding active and reactive power limits are provided. Current grid code requirements regarding the rotor angle stability are presented. Based on the actual trend of increased penetration of both solar and wind, the challenges to be expected in future are illustrated by means of generic 12-bus power system model.

Commented [F1 1]: Update/align

### 3.1 Background

Rotor Angle Stability of power systems determines how conventional power plants can remain in synchronism following a relatively large disturbance such as an imbalance between generation and consumption. According to source of the imbalance, the electrical power ( $P_e$ ) or mechanical power ( $P_m$ ) decelerates or accelerates rotors of synchronous generation in conventional power plants connected to a power system. These acceleration or deceleration can cause deviation of rotor angles and also bus voltage angles. Beyond stability limits, an increase in these angular separations between buses and power plants results in a decrease of the power transfer such that the angular separation is increased further. Thus, the instability occurs if the power system cannot decrease the angle deviations and cannot damp the oscillation of these deviations.

Low frequency power oscillations (LFPO) have been registered in power systems from their early days of existence. Many incidents of synchronous machine hunting were experienced in the thirties of the 20th century [1]. Typically, stator winding and transmission lines may induce negative damping torque on the rotor and cause system instability. Damper windings has been introduced for mitigating this problem. However, the problem of low frequency oscillations reappeared in sixties together with introduction of fast automatic voltage regulators (AVR) and increase of bulk power transmission distances [1]. The main concern was the inadequate level of damping, which could be close to zero or even negative. This means that under a disturbance the power systems may experience growing oscillations, which eventually lead to instability and the system separation into isolated sub-systems. Even stable oscillations may result in line tripping as the large current and voltage swings may trigger distance relays that protect transmission lines [2]. Consequently, LFPOs were the root cause or were partially involved in most of the major blackouts that happened worldwide throughout decades, including [3] and [4]:

- Finland-Sweden-Norway-Denmark (1960s),
- Saskatchewan-Manitoba Hydro-Western Ontario (1966),
- South East Australia (1975)
- Scotland-England (1978),
- Taiwan (1985),
- West USA/Canada (1996),
- North-east USA and Ontario Canada (2003),
- Italy (2003)

One of the most recent inter-area oscillation occurrences was experienced in the European synchronous area (UCTE) on the 19th of February in 2011 [5]. A 15-minute long 0.25Hz oscillation was recorded on the south-north axis, with power swings over tie-lines reaching  $\pm 150\text{MW}$ . The event was most observable in the middle-south part of the system.

With the large integration of ReGen plants, the rotor angle stability of power systems might be adversely affected in the future [6]. Since the converter technologies in ReGen plants are insensitive to the rotor angle deviations in power systems, advanced control methods are required for ReGen plants. Power System Stabilizer functionality provided by WPPs connected to Transmission Systems has been proposed and investigated in [7] and [8]. One of the conclusions in [8] is that WPPs can provide PSS like functionality. However, the tuning of the PSS is very important and dependent on the input/output pair combinations and the measurement location (remote or local). Tuning of PSS controller shall also be coordinated in order to maintain stability of power system [8]. Moreover, WPPs have to be curtailed to provide the required contribution otherwise overloading of individual WTGs will occur.

The above mentioned challenges are getting new dimensions when considering ReGen plants connected to both Transmission and Distribution Systems for provision of PSS functionality. The large WPPs may have direct communication channels to TSO, however the small and medium size WPPs connected to MV distribution grid are not yet coupled to the TSO's SCADA system. Large scale PV plants (tens of MW range) are connected to MV distribution grid and have their power output highly dependent on solar irradiation especially in fast moving clouds conditions. Thus, the PSS functionality may be achieved only by providing reactive power injection according to measured LFPO. The structure of distribution grid where these ReGen plants are connected shall be also taken into account.

Current grid codes do not include any requirements from ReGen plants in terms of support to the rotor angle stability however, they require different minimum and maximum power oscillation damping levels e.g. in the UK grid code [9].

### 3.2 Objectives in WP4

WP4 aims to investigate the feasibility of Rotor Angle Stability support from ReGen Plants connected to both transmission and distribution grids. Considerations about observability and controllability of LFPO taking into account aggregation of this service but also some ICT aspects are made starting from a small signal stability analysis of a representative power system with various penetration levels of ReGen. This analysis will provide insight on which capability of ReGen Plants namely active or reactive power shall be utilized for enhancing the Rotor Angle stability support. Also, identifying feasible measurement points to provide the required



functionality is in scope. Considerations about impact of ICT on overall control schemes for PSS like functionality from ReGen plants are made.

The following assumptions are considered in WP4:

- Since non-linear equations of conventional and ReGen plants are difficult to analyze and the rotor angle oscillations can be triggered by a small disturbance, it is sufficient to analyze the linearized model of the power system with ReGen plants.
- ReGen plants are represented as aggregated and simplified PQ source connected to a representative transmission system model.
- Model bandwidth of the PQ source is chosen to match the typical control bandwidth of WPPs and PVPs. Thus, DC-link voltage and current controllers dynamics including the grid synchronization (Phase Lock Loop) are neglected.
- Small signal stability analysis is performed only for a transmission grid due to complexity and variety of distribution grids that are increasing the computational effort. However, the findings of this analysis will consider the ReGen plants connected to distribution system. It is also believed that inclusion of distribution grids in the small signal analysis will not provide additional information to the study.

## 4 Active and Reactive Power Control Capabilities of ReGen Plants

This chapter summarizes the technical capabilities of ReGen plants for active and reactive power control. The definition of the most important parameters is presented by means of state-of-the-art analysis, predominantly originating from the results of [10].

### 4.1 Technical Capabilities of Wind and Photovoltaic Power Plants

In today's distribution systems fixed-speed (type 1), limited variable speed (type 2) and variable speed WTs (type 3 & 4) are present to a large extent. While the former WTs (type 1 & 2) are practically obsolete, they are used at a number of older WPPs and are not expected to be replaced by more modern WTs until they reach the end of their economic life, typically 20 to 25 years from installation. Type 1 and 2 WTs consume reactive power, whose supply is normally ensured by shunt capacitor banks installed at the turbine terminals. However, they are not capable to actively control voltage according to the functional specifications considered for coordinated voltage control. Hence, only the technical capabilities of WPPs with variable speed WTs (type 3 & 4) are presented and considered in RePlan.

Subsequently, various plant functionalities are evaluated based on estimations from manufacturers and developers coming from questionnaires, interviews, and these functionalities are also complemented by the

#### 4.1.1 Reactive Power Setpoint Processing Functionality

This capability is needed to be able to receive setpoints for the selected control mode including the change of the mode. Table 2 summarizes the WPP capabilities related to the stipulated grid code.

Table 1: Wind Power for Q Setpoint Processing Functionality

Feature	Grid Code Requirement	WPP Capability
Setpoint setting	0.95 to 1.05 pu in steps no greater than 0.01 pu	Yes
Commencement of response	Within 2 s	100 – 200 ms
Rise time	1 – 5 s	< 1 s
Settling time	10 s	≥ 1 s
Steady-state reactive tolerance	±5 % of $Q_{max}$	Yes

#### 4.1.2 Reactive Power Provision Functionality

Reactive power can be supplied up to certain values which are defined by PQ diagrams. Table 3 summarizes the WPP capabilities for both type 3 and type 4 WTs related to the stipulated grid code requirements

Table 2: Wind Power Plant Capabilities for Q Provision Functionality

Feature	Grid Code Requirement	WPP Capability	
		Type 3	Type 4
Max. range of Q/P <sub>max</sub> during normal operation	0.33	Yes	Yes
Max. range of Q/P <sub>max</sub> during standstill	0.33	0.2	Yes

Reactive power can be supplied up to certain values which are defined by PQ diagrams. Table 4 summarizes the PVP capabilities related to the stipulated grid code requirements

Table 3: Photovoltaic Power Plant Capabilities for Q Provision Functionality

Feature	Grid Code Requirement	PVP Capability
Max. range of Q/P <sub>max</sub> during normal operation	< 1, dependent on actual active power	Yes
Max. range of Q/P <sub>max</sub> during standstill	1	Yes

## 4.2 Technical Capabilities of ReGen Plants applied in RePlan

Based on the state-of-the-art analysis the following technical capabilities of ReGen plants for voltage control are considered in this study:

- Active and Reactive power setpoint processing functionality: Both WPP and PVP are able to achieve a new power setpoint within 1 second.
- Reactive power provision functionality: according to the PQ capability charts shown in Figure 1.

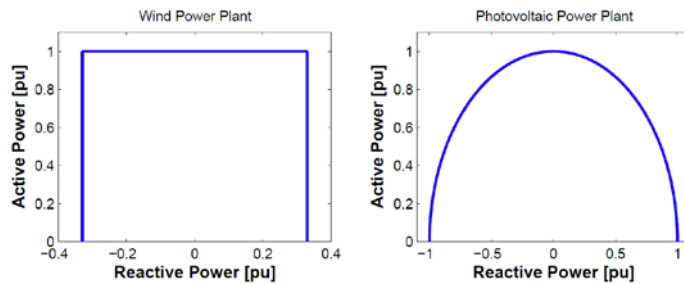

Figure 1: Active/Reactive Power Capability charts for wind power and photovoltaic power plants

Important to notice that the PQ chart capability of WPPs are valid for both HV and MV connection while PVPs are connected only to MV grids.

Overall the ReGen plants shall be able to modulate their power output according to the selected measurement that will contain information about rotor angle stability i.e. voltage in a specific bus or given generator speed.

## 5 System Models for Rotor Angle Support

In this chapter the models used in WP 4 are described. First, the generic power system model is described. It will be used to perform small signal analysis related to RAS stability support of ReGen plants. Secondly, ideal PQ source models for the ReGen plants are explained.

### 5.1 Generic 12-bus Model

A generic 12-bus model that supports different penetration levels of renewable energy is initially defined in [11] and used for studying ancillary services in [6], [7] and [8].

#### 5.1.1 Assumptions and limitations

The following assumptions are used for the generic 12-bus model [6] and [11]:

- Model consists of different share of conventional power plants with generator models in these plants including dynamics of rotor circuit and damper windings.
- Conventional power plant models are including excitation and AVR with different settings that are providing at least a fast and a slow response.
- Model is capturing 3 mode shapes in the range 0.1 to 3 Hz which are typically characteristic for LFPO.
- Increase demand from loads is covered by an increase of ReGen power while conventional power plants' installed capacity is kept at the same level. This is typically happening in countries with incentives for wind power in the early stages of development e.g. Denmark, Germany, UK, etc. Some levels of wind power penetration may require reinforcement of lines; however no major changes in the network layout are expected.
- Increase penetration of RE for the same demand is achieved by closing some conventional power plants. This is typically in countries where ReGen power is reaching a relatively high penetration level e.g. 20% and there is no major increase in the load demand. Governmental policies are requiring more RE and some of the thermal power plants are closed. A typical example for this trend is Denmark.

#### 5.1.2 Model characterization

The generic 12-bus system represents a small isolated power system with four areas. Its layout is shown in Figure 3.

Power generation is dominated by the thermal plants (generators: G1, G2 and G3), as it is typical for many power systems, e.g. in UK, USA or Germany. Area 1 is a generation rich area with some industrial and residential loads. Area 2 is a lightly loaded area with some hydro generation (G4). On the other hand, Area 3 is a heavily industrial load centre with some local thermal power generation, that is insufficient to cover the area's demand. Hence, the power needs to be imported from the other areas, which forces a high load on the tie-lines. Large off-shore WPPs are considered to be connected to Bus 4 in high RE penetration scenarios, while a combination of on-shore ReGen plants (i.e. WPPs and PVPs) are connected to Bus 3. Finally, Area 4 is a lightly loaded area that offers a high wind power generation potential. As for Area 3 ReGen plants consisting both of medium size on-shore and large scale off-shore WPPs as well as large scale PVPs are considered to be connected to Bus 5.

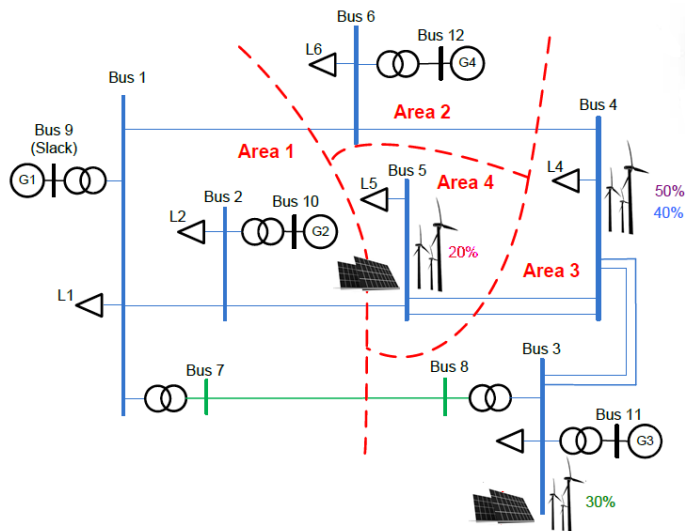

Figure 2: Structure of Generic 12-bus Model with ReGen Power Plants (based on [10]).

This Area 4 is the weakest part of the system, as it is shown by the bar plot of fault level for various buses in Figure 4. This means that the voltage at the PCC of ReGen plants is very sensitive to power fluctuations. However, such difficult interconnection conditions are characteristic for today's large WPPs but also PVPs, where the short circuit ratio (SCR) can get as low as 2.

The Figure 4 complements the information on bus properties with the voltage profile.

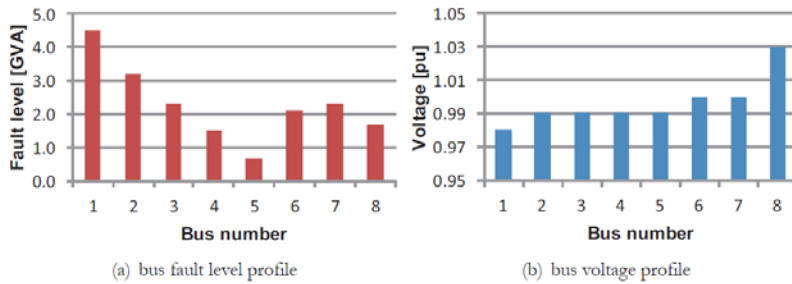

Figure 3: Characterization of buses according to [6].

## 5.2 ReGen Penetration Scenarios

Several operational scenarios are considered for the generic power system model. These scenarios reflect different ReGen penetration onto the power grid. ReGen penetration is defined here as the ratio between installed capacity of conventional power plants and the installed capacity of ReGen plants. There are assumed two trends in development of the power system as:

- Increase demand from loads covered by an increase of ReGen plants while CGUs' installed capacity is kept at the same level. Some levels of ReGen penetration may require reinforcement of lines; however no major changes in the electrical infrastructure are expected.
- Increase penetration of ReGen power for the same demand while closing some CGUs.

These trends regarding ReGen penetration are shown in Table 5.

Table 4. ReGen penetration scenarios on generic 12-bus system.

Scenario	0%	20%	30%	40%	50%
CPP [GW]	2	=	↘	↘	↘
Loads [GW]	1.5	↗	=	=	=
ReGen [GW]	0	↗	↗	↗	↗

### 5.3 ReGen Plant Models

#### 5.3.1 General assumptions and limitations

The following common assumptions and limitations for the ReGen Plant models are considered:

- Aggregation of plant, i.e. internal grid and individual assets is neglected.
- Frequency bandwidth of the models is maximum 5 Hz.
- Power curtailment and frequency control are not considered.
- Reactive power is considered to be controlled in Point-of-Connection (PoC) of the plant.
- Fault-ride through capability of the plant is not taken into account.
- Protection functionalities e.g. voltage limits, frequency limits, current limits, etc. are not taken into account.

#### 5.3.2 Model Characterization

Both WPP and PVP are considered as controlled PQ sources. Thus, they are modelled as a first order delay as shown in Figure 4. This is a simplified approach of the ReGen plant models used in [12]. This representation is sufficient for small signal stability analysis as is capturing only the dynamics of the main control loops at plant level [7].

**Commented [LP2]:** I believe it could be useful to have an additional section explaining shortly how the conventional power plants are modelled. I know it is standards, but still... to have a complete model overview!

**Commented [LP3]:** There is something wrong with the references. Can't find number 12 in the reference list. Only until 9.

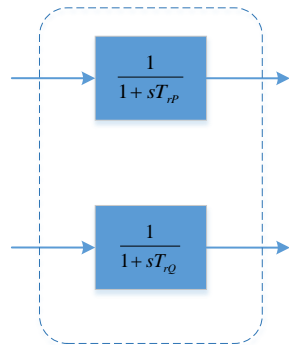

Figure 4: Block diagram of ReGen modules.

Commented [LP4]: Mention the values for Trp and Trq for WPP and PVP!

## 6 Small Signal Stability Analysis

This chapter presents the methodology for the analysis of LFPO to analyze RAS. As mentioned in the assumptions' the linear differential-algebraic model of the generic 12-bus model is transformed into standard state-space form that is commonly used for control law derivation and analysis. Using eigenvalue decomposition a number of indices which are very informative with respect to the system oscillatory properties can be formulated. Further on the methodology for analysis of input and output signals usefulness for damping control formulation is given.

### 6.1 Observability and Controllability Analysis

In general power systems are complex, non-linear dynamic systems. As every dynamic system they can be described by a set of non-linear differential equations. However, the dynamics speed involved in the power system operation can range from microseconds to hours. For instance wave-like propagation of switching transients takes place in a microsecond timespan, while the time frame of steam power plant boiler thermodynamics is from minutes to hours. Consequently the dynamic variables of the differential model can be ordered based on their time constants [7]: *In chapter 2 it has been shown that the installed capacity of ReGen plants may affect the electromechanical modes of power system.*

$$\begin{aligned}
 T_s \dot{x}_s &= \mathbf{e}(x_s, x_d, x_a, u) \\
 T_d \dot{x}_d &= \mathbf{f}(x_s, x_d, x_a, u) \\
 T_a \dot{x}_a &= \mathbf{g}(x_s, x_d, x_a, u) \\
 y &= \mathbf{h}(x_s, x_d, x_a, u)
 \end{aligned} \tag{1}$$

where  $x_s$  is the vector of slow dynamic variables,  $x_d$  is the vector of variables having time constants close to inter-area oscillation frequencies,  $x_a$  is the vector of fast variables,  $u$  and  $y$  are the vectors of input and output variables. In the context of inter-area oscillations (1) means that some transients will already die-out much before the first swing of the involved generators completes. Hence, the detailed information on progression of quickly changing variables is not essential [7]. Therefore, the related variables may be assumed to stay

constant within the power system oscillatory stability time frame. Additionally, (1) can be converted to state space form considering small signal deviations as follows:

$$\begin{aligned}\Delta \dot{x}_d &= \mathbf{A} \Delta x_d + \mathbf{B} \Delta u \\ \Delta y &= \mathbf{C} \Delta x_d + \mathbf{D} \Delta u\end{aligned}\quad (2)$$

where A,B,C and D are coefficient matrices and  $\Delta$ -notation signifies the small-signal changes of the variables around an operating point.

Since matrix A is typically non-diagonal, the evolution of one variable is coupled to the evolution of the other variables. However, any square matrix can be diagonalised, or at least brought to Jordan canonical form, by solving left or right eigenvalue problem:

$$\begin{aligned}\mathbf{A} \Phi &= \Phi \Lambda \\ \Phi \mathbf{A} &= \Lambda \Psi\end{aligned}\quad (3)$$

$$\begin{aligned}\dot{z} &= \Lambda z + \Psi \mathbf{B} u \\ y &= \mathbf{C} \Phi z + \mathbf{D} u\end{aligned}\quad (4)$$

$$x = \Phi z \quad (5)$$

where  $\Lambda$  is the diagonal (or block diagonal) matrix of the A matrix eigenvalues,  $\Psi$  and  $\Phi$  are the matrices of left- and right-eigenvectors respectively. According to the Lyapunov's first method, if all eigenvalues have negative real parts, the system is asymptotically stable. Moreover, complex modes represent oscillatory dynamics, where the real and imaginary parts of the corresponding eigenvalue quantify the damping and frequency of the oscillation respectively. Analysis of the angle of the right eigenvector elements ( $\Phi$ ) displays the phase displacement between the motion of individual states. For power systems this property of right eigenvectors is used to identify so called mode shapes, i.e. to categorise all conventional power plants into coherent groups that are swinging together if a particular mode is excited. On the other hand, from (4) it can be observed that the left eigenvectors determine how modes are excited by the current condition of the original state-space  $x$ . Concluding, eigenvectors describe mutual relation between modal and power system variables. However, due to natural scaling of physical-related state space, which usually is not globally normalised, it is not possible to compare how much different variables participate in an oscillation. Therefore, another very useful modal index is the participation factor:

$$p_{ik} = \Psi_{ki} \Phi_{ik} \quad (6)$$

which measures how much  $i$ -th state participate in  $k$ -th mode. Because participations are dimensionless, the variable scaling problem is eliminated and relative state activity in a specific mode can be identified. Additionally,  $\Psi \mathbf{B}$  in (4) can be used as the mode controllability matrix to control the mode with the related input. Similar to the controllability,  $\mathbf{C} \Phi$  can be used as the mode observability matrix to observe the mode at the related output [2]. Based on these theoretical explanations, in Section 6.3 the results of the small-signal sensitivity analysis are presented.



## 6.2 Results and Analysis

In this section, results of the rotor angle stability of the generic power system are presented. These results can be employed in order to develop the support of the rotor angle stability and tune this support.

### 6.2.1 Mode Shapes

The Mode shape analysis as mentioned in the previous section is performed and the results are presented in Figure 6. When the wind power penetration level is increasing, the mode shapes for all of the oscillatory modes are changing. Mode 1 is dominated by G3 plant and Mode 3 is dominated by G4 plant while all generators significantly contribute to the Mode 2. For all the modes, after 20% wind power penetration level, the coherency between the generators are not changing so much such as in Mode 2, G1 and G3 swing against G2 and G4. This is an important conclusion for this power system.

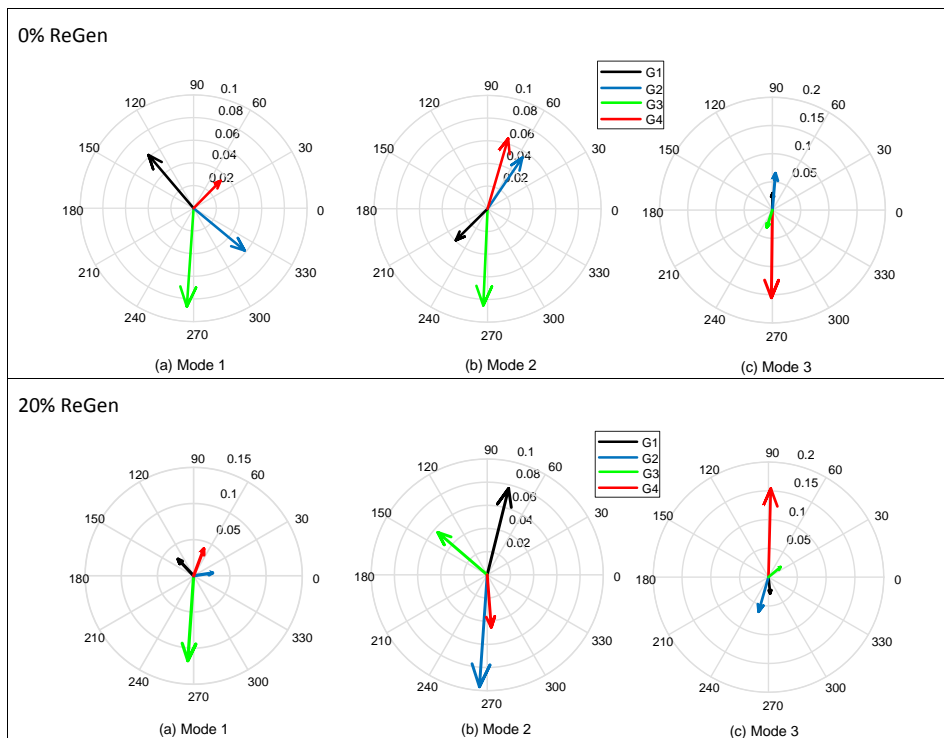

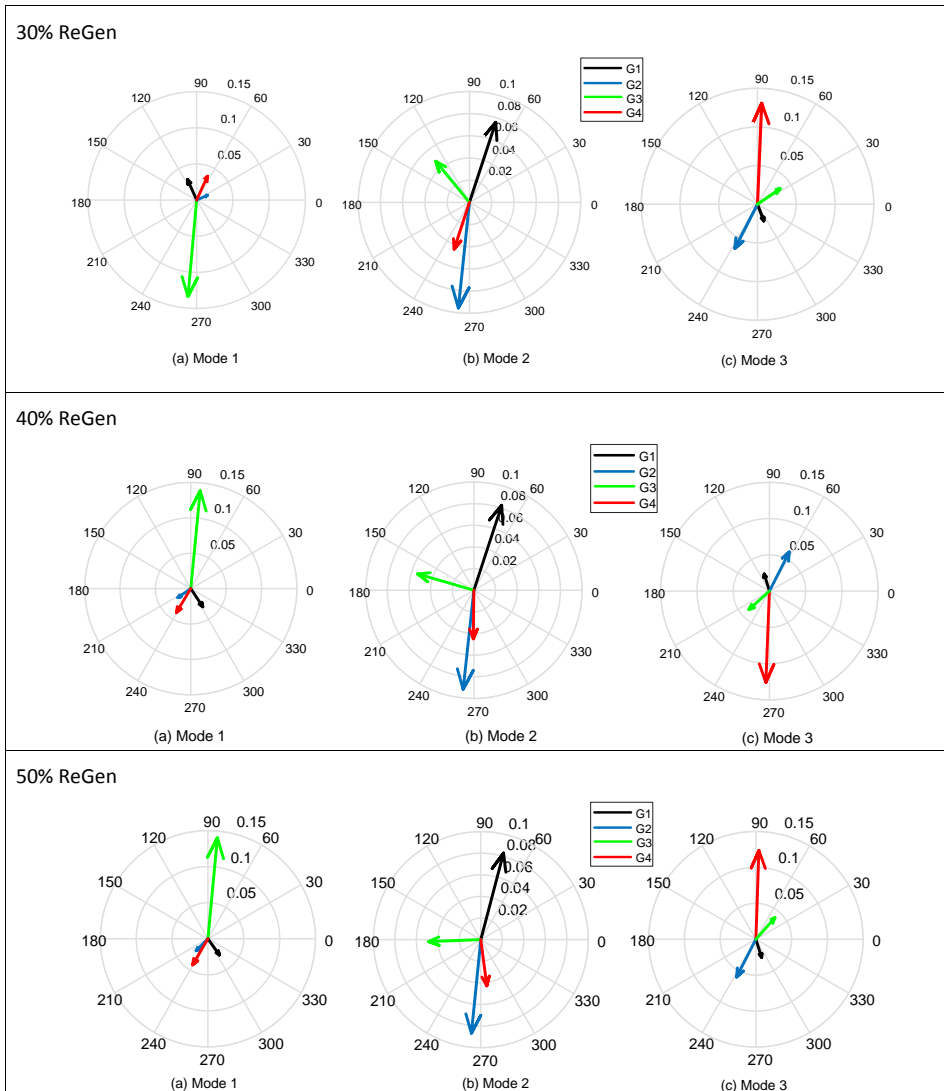

Figure 5: Comparison of the inter-are mode shapes in the generic power system

### 6.2.2 Participation Factors

To understand better how the individual generators are contributing into rotor angle oscillations, the normalised participation factors for generator speeds are shown in Figure 6.

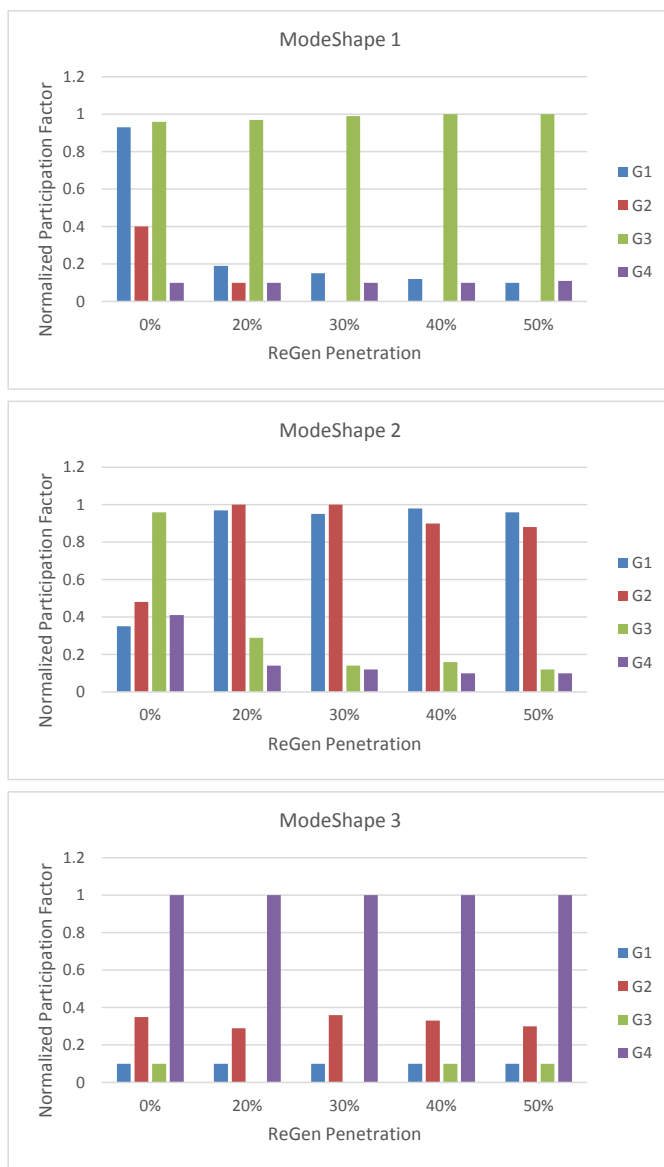

Figure 6. Normalized participation factors of Generator speeds for Mode Shapes.

Generator 3 is mainly contributing to Mode Shape 1 in all RE penetration scenarios. Mode Shape 2 is a combination of participation from G1 and G2 for RE penetration G2 being dominant in 20% and 30 % scenarios while G1 is having the main contribution for 30% and 40% RE penetration. Mode Shape 3 is mainly

given by G4 irrespective of penetration scenarios. Worth to mention that G4 is mainly hydro based generation units.

### 6.2.3 Observability of Mode Shapes

Utilizing the formerly introduced modal observability values of the related mode, it can be analyzed how the modal information propagates spatially through the power system. Due to the variable scaling problem, comparing absolute values for different observability variables is not meaningful. It is rather important to observe how for different variable types the relative observability is distributed throughout the system. For sake of simplicity the 0% ReGen penetration is not shown for observability analysis. Two types of measurements/variables can be considered to monitor the LFPO into the power grid. First choice is to consider a direct measurement of the rotor angle/speed in each conventional generation units. The mode shape's observability for rotor angle is shown in Figure 7.

Clearly Mode Shape 1 is best seen when monitoring rotor angle/speed of G3 as expected from participation analysis. Again, the high observability of Mode Shape 2 from G1 and G2 when monitoring rotor angle is confirmed. As expected Mode Shape 3 is best seen monitored via the rotor angle of G4. Overall, high observability indices should be considered in practical applications for capturing properly LFPO.

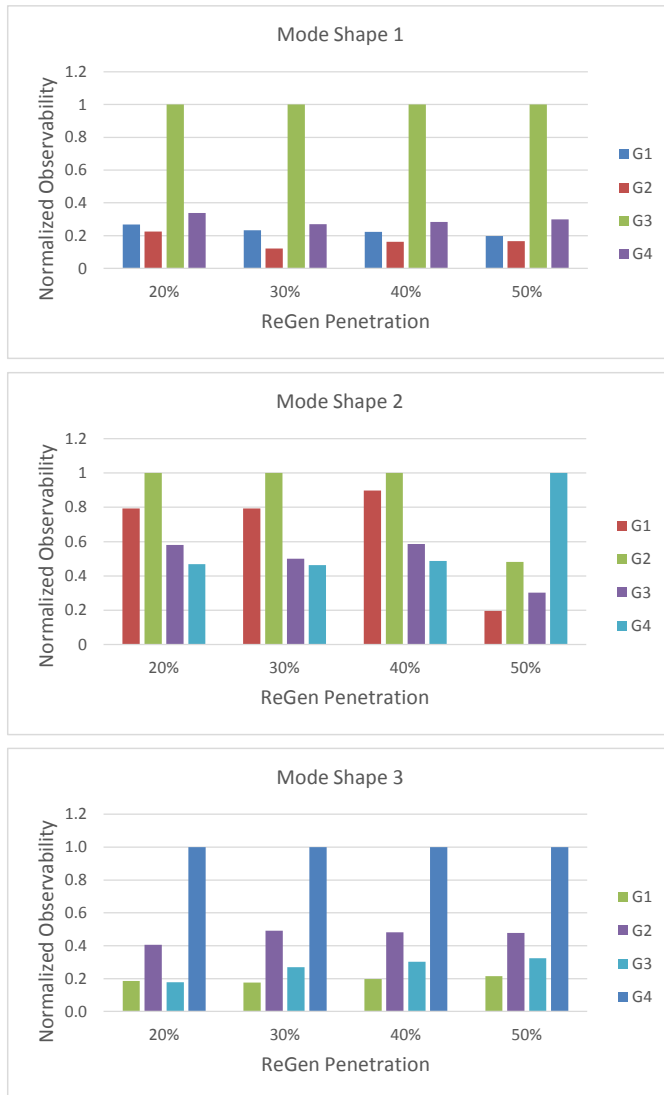

Figure 7: Rotor Angle based Observability of Mode Shapes

Normalized observability indices of mode shapes by measuring bus voltages are given in Figure 7. Measuring voltages on a given bus and sending the signals to remote connected ReGen plants may introduce other challenges related to time synchronization, possible delays due to ICT, etc. More considerations on this will be made in Section xx. Hence, it is relevant to consider mainly those buses where the aggregated ReGen plants are connected.

Commented [LP5]: Fig. 8

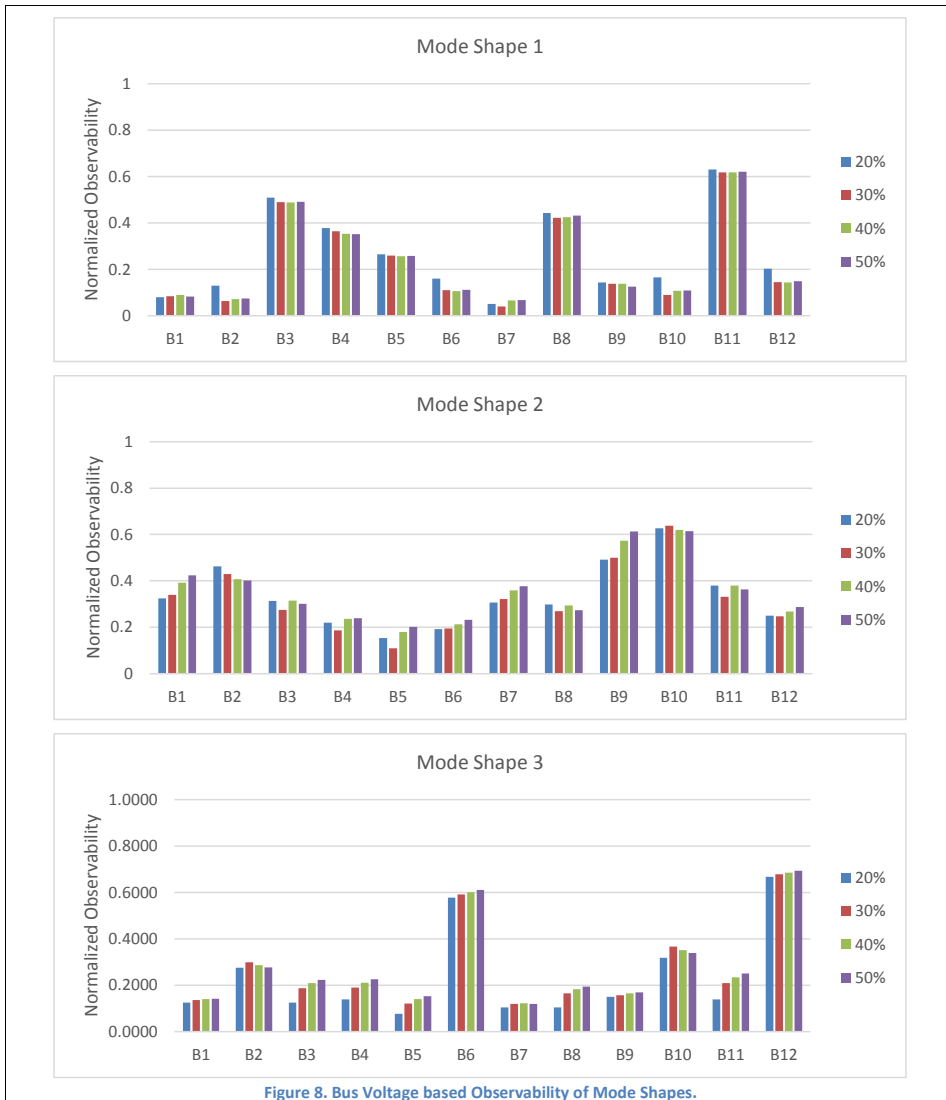

Figure 8. Bus Voltage based Observability of Mode Shapes.

Bus 3 has higher observability for Mode Shape 1 compared to other two in all considered penetration scenarios. Thus, a PSS like functionality using the voltage measurements on this bus will make sense mainly for Mode Shape 1.

Bus 5 has low observability for all modes in all penetration scenarios. Hence PSS like functionalities may not be effective for the ReGen plants connected to this bus.

### 6.2.4 Controllability of Mode Shapes

The modal controllability analysis is revealing how effective active and reactive power injection is in a specific bus on damping of a particular mode shape. This additional power contribution is, in this case, provided by the ReGen connected to that bus. The analysis is considering different RE penetration scenarios i.e. 20% to 50% and the results are shown only for Bus 3, Bus 4 and Bus 5 where aggregated ReGen are connected. The evaluation of results is considering penetration trends and a normalized controllability index of 0.2 as a minimum contribution.

The normalized controllability indices for Bus 3, Bus 4 and Bus 5 are given in Figure 9, Figure 10 and Figure 11 respectively.

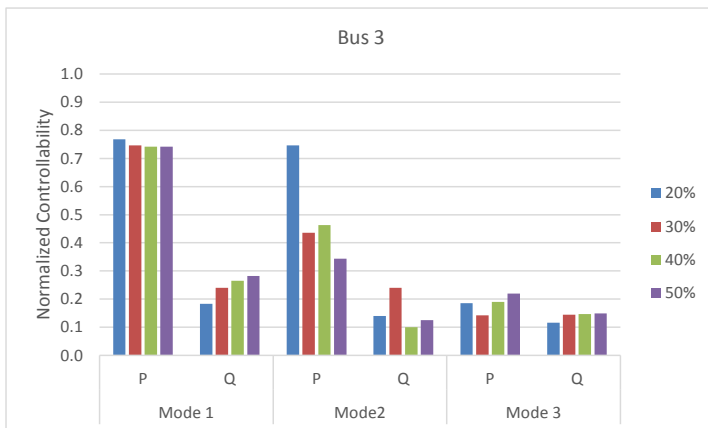

Figure 9: Normalized Controllability indices for active and reactive power injection on Bus 3.

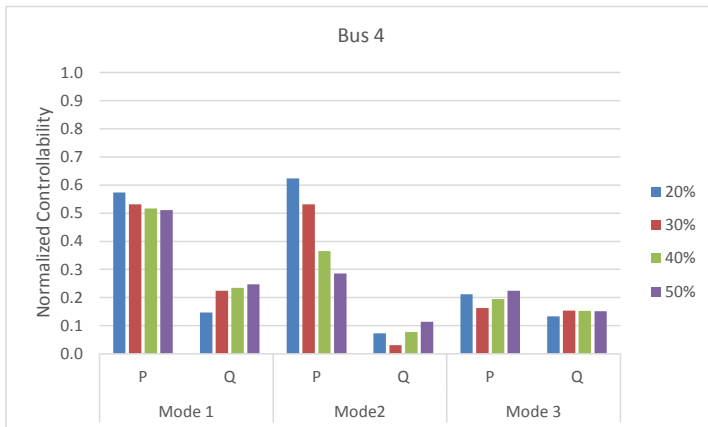

Figure 10: Normalized Controllability indices for active and reactive power injection on Bus 4.

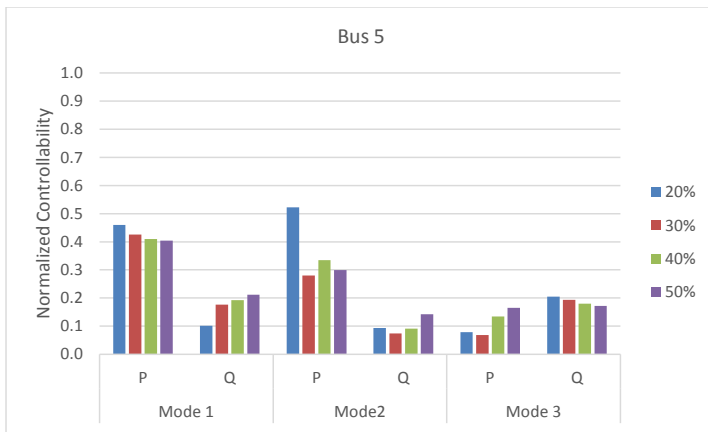

Figure 11: Normalized Controllability indices for active and reactive power injection on Bus 5.

Injection of active power is clearly very effective for Mode Shape 1 irrespective of RE penetration level while reactive power based damping can be used as an alternative. Mode Shape 2 can also be damped by using active power injection however Q based damping is not effective.

Active power based damping of Mode Shape 1 on bus 4 is an evident choice, its effectiveness being slightly reduced with RE penetration level. Mode Shape 2 can also be damped with additional active power injection especially on 20% and 30% penetration scenarios. However, controllability indices are reduced to almost half in high penetration scenarios.

Damping of Mode Shape 3 seems to be achievable only by using P injection on Bus 3 and Bus 4 with an average index less than 0.2 in all penetration scenarios. Q based damping of Mode shape 3 may be achieved only on Bus 5.

Overall, the analysis performed on this particular power systems reveals that active power based damping seems to be more suitable than the reactive power based one. However, this is requiring curtailment of the ReGen plants

**Commented [LP6]:** So is it a conclusion that in general P contribution is more effective than Q contribution? Or dependent on the system? I believe it is important to emphasize here, since you stated in the introduction that ReGen plants will mainly be able to contribute with Q due to limited P availability..

## 7 Considerations on RAS support implementation

Several control architectures were proposed for considerations in RePlan Project [13]. In this section some considerations about implementing Rotor Angle Stability support using ReGen Plants are made.

### 7.1 RAS Support Functionality

A generic PSS scheme for damping of LFPO is presented in Figure 12 based on [7] and also utilized in [8]. This PSS scheme should be used for implementing RAS support functionality and shall be implemented at ReGen Plant Control Level (L0) as defined in [13].



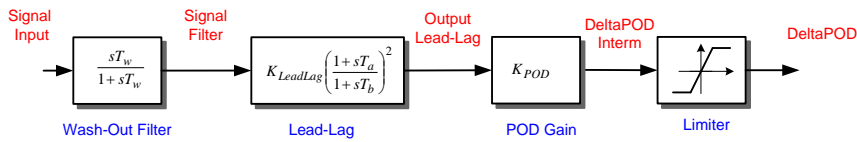

Figure 12. Generic power system stabilizer scheme for RAS support.

The tuning procedure for this is detailed in [7] and also used with success in EASEWind project [8]. Selection of inputs and output shall be made according to procedure presented in Section 6. Clearly the most suitable candidate for inputs signal will be the voltage amplitude in the PCC of ReGen Plant while modulating active power of the ReGen plants was effective in most of the studies presented in Chapter 6. ICT may have a major impact if remote PoM are used.

## 7.2 Control Architectures

RAS support may require a centralized approach as proposed in [13] and shown in Figure 13.

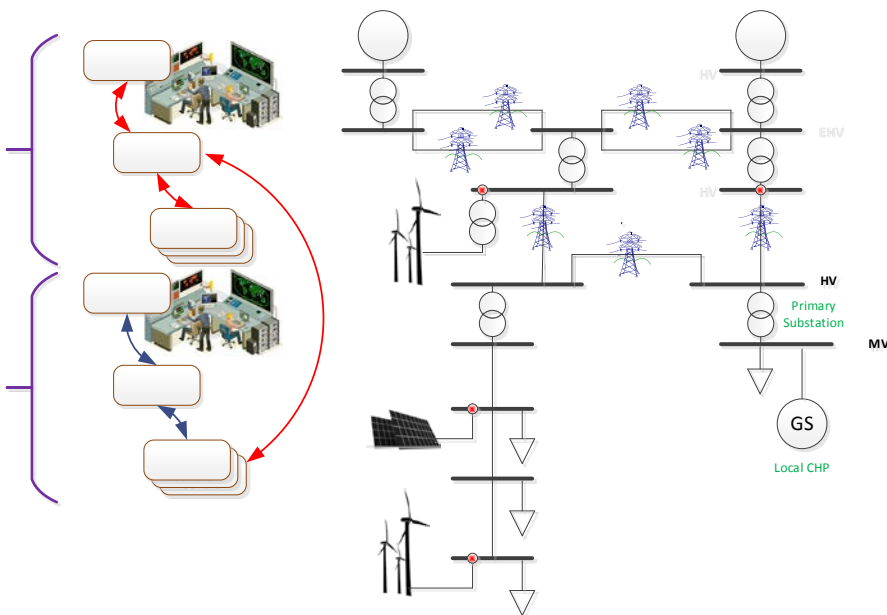

Figure 13. Centralized architecture for RAS support (based on [13])

These PSS schemes cannot be implemented at aggregator control level (L1) due to specific requirements in terms of phase of input signal and the required contribution from ReGen plant measured in PCC [7]. However, tuning of the parameters can be done according to specifications from TSO Level (L2). An aggregator Level (L1) may perform the tuning for several ReGen Plants based on Inputs from L2. In this way coordination between several plants may be achieved. The above are valid for units connected to Transmission System. Feasibility of utilizing RAS support from ReGen Plants connected to distribution systems is highly depending

on DS topology. ReGen plants connected along the radial MV feeders may cause instability of voltage profiles when modulating the power output according to the input signal from their PCC. Hunting effect can easily occur especially if deviation in the phase on In/Out signal pair occur. Other generation units connected to the MV grid e.g. CHPs can also impact stability of the distribution network. Ideally is to use the ReGen plants directly connected to primary substations which may be the case with on-shore WPPs. As shown in Chapter 6 implementing active power based RAS support in PV plants may not be feasible due to rapid changes in power output of these plants. However, a reactive power based RAS support may be feasible. Meshed or ring distribution grids having two or multiple connections to transmission systems may require further analysis to identify feasibility but also stability issues. In this case injecting a modulating power in multiple connection points in the transmission grid may create adverse effects. Through small signal stability studies with focus on observability but also controllability must be performed.

### 7.3 ICT impact on RAS Support schemes

Implementation of RAS support schemes at plant control level will ensure proper data exchange between local PoM and PCC in all configurations and type of ReGen plants. Thus, no ICT impact is expected in this case. ICT may impact performance of on-shore ReRen Plants if remote PoMs are used for input signal in the RAS support function. Especially, using public network may have an impact on provision of this service [14].

**Commented [LP7]:** May it also be the case that a ReGen plant needs to use input signals coming from other buses (e.g. voltage) due to higher observability on these buses? In this case the ICT impact plays a special role. But it might be that I misunderstood...

## 8 Conclusions and Recommendations

This document is presenting RAS challenges in power systems with high penetration of renewables. A small-signal stability based assessment is chosen and used on a representative 12-bus generic power systems having different RE penetration levels, and exhibiting 3 main mode shapes. The small signal stability study includes an eigenvalue analysis followed by an assessment of obtained normalized indices for participation factors, observability and controllability. Some considerations about feasibility and suitability of control schemes and architectures from a practical perspectives are included.

The main conclusions of this work can be summarized as follows:

- RAS support must be considered thoroughly and no general applicable solution exists.
- Power system topology and especially settings in primary control loops in CGUs e.g. prime movers and excitation are having a significant impact on Mode Shapes, thus properties of LFPO. Increased penetration of renewables are also affecting mode shapes
- Observability of Mode Shapes is depending on location of ReGen Plants. Typically, local measurements on PCC may not provide sufficient level of observability of a particular mode shape. Remote measurements may increase observability however, ICT shall be careful considered in these cases
- Active power based controllability of Mode shapes seems to be efficient in most of the studied scenarios while reactive power based one may be limited. Again these results are highly dependent on power system topology, parameters and penetration levels. Studies performed in a different system may reveal other conclusions.

- WPPs may be a feasible provider of this service with both active and reactive power based RAS support. PV plants may provide a reactive power based RAS support as the active power output is highly dependent on solar irradiance in a given location.

Based on the work done in WP4 the following recommendations are made:

- Suitability and feasibility of RAS support should fall under TSO attributions. This is the only entity having the sufficient level of information necessary for obtaining meaningful results i.e. actual grid topology, settings on CGUs, expected penetration and location of ReGen including units connected to distribution grids.
- A small signal model of the power grid shall capture the relevant topology both transmission and distribution (aggregated) and shall provide the main mode shapes of interest. Building this model may be challenging for interconnected power grids as the ENTSO-E one. In this case aggregation shall be considered. The existing models for planning purposes may not contain the relevant information required for RAS investigations i.e. structures and settings for prime movers and excitation systems.
- Feasibility studies based on a small signal model of the entire considered system shall include at least eigenvalue analysis, followed by an assessment of normalized indices for participation factors, observability and controllability.
- Tuning of RAS support functionality shall be based on the small signal model
- Time domain assessment of RAS support shall be performed on a dynamic model representing the power grid.

**Commented [LP8]:** It would be good to emphasize how much is necessary to be modelled for ReGen plants (1<sup>st</sup> order time response), since this may not be known to many people

As future work the following aspects may require attention in future:

- Investigate feasibility of provision of RAS from ReGen plants connected along meshed or ring distribution feeders.
- Investigate power system stability (voltage, transient) including interaction with other dispersed generation units when RAS support is provided by ReGen plants connected inside distribution network on radial, meshed or ring feeders.
- Investigate ICT impact of public networks on provision of RAS support.
- Demonstrate using time domain studies feasibility of RAS support including ICT impact.

## References

- [1] D. P. S. G. a. I. Sen., Low frequency oscillations in power systems;, Sadhana, 1993.
- [2] U.-C. P. S. T. Force, Final report on the august 14, 2003 blackout in the United States and Canada;, April 2014.
- [3] B. P. a. B. Chaudhuri, Robust Control in Power Systems, December 2010: Springer.

- [4] N. M. a. D. T. K. Prasertwong, "Understanding low-frequency oscillation in power systems," *International Journal of Electrical Engineering Education*, vol. 47, no. 3, pp. 248–262, 2010.
- [5] T. R. ENTSO-E, Analysis of CE inter-area oscillations of 19 and 24 february 2011, ENTSO-E, August 2011.
- [6] M. Altin, "Dynamic Frequency Response of Wind Power Plants", PhD Thesis, Aalborg University, Aalborg, Denmark, 2012.
- [7] A. G. Adamczyk, "Damping of Low Frequency Power System Oscillations with Wind Power Plants", PhD Thesis, Aalborg University, Aalborg, Denmark, 2012.
- [8] A. D. H. Mufit Altin, "Impact of advanced wind power ancillary services on power system," DTU ISBN 978-87-93278-05-9, January 2015.
- [9] National Grid, "The Grid Code," National Grid, 2017.
- [10] F. H. e. al., "Grid support services by wind and solar PV: a review of system needs, technology options, economic benefits and suitable market mechanisms. Synthesis report of the REserviceS project," REserviceS project, 2014.
- [11] A. G. Adamczyk, M. Altin, Ö. Göksu, R. Teodorescu and F. Iov, "Generic 12-Bus Test System for Wind Power Integration Studies," in *EPE Joint Wind Energy and T&D Chapters Seminar*, Aalborg, Denmark, 2012.
- [12] e. a. L. Petersen, "D2 Voltage Control Support and Coordination between Renewable Generation Plants in Distribution Systems," RePlan Project, 2018.
- [13] M. A. K. S. R. L. O. F. I. A. D. H. X. H. Lennart Petersen, "D1.1 Specifications for ReGen plant model and control architecture," December 2015.
- [14] e. a. K. Shahid, "Communication aspects in Replan, Internal Technical Report," 2016.

~~[1] D. P. S. G. a. I. Sen, "Low frequency oscillations in power systems," Sadhana, 1993.~~

~~[2] U. C. P. S. T. Force, Final report on the august 14, 2003 blackout in the United States and Canada, April 2014.~~

~~[3] M. Altin, "Dynamic Frequency Response of Wind Power Plants", PhD Thesis, Aalborg University, Aalborg, Denmark, 2012.~~

~~[4] A. G. Adamczyk, "Damping of Low Frequency Power System Oscillations with Wind Power Plants", PhD Thesis, Aalborg University, Aalborg, Denmark, 2012.~~

~~[5] National Grid, "The Grid Code," National Grid, 2017.~~

- [6] A. G. Adamczyk, M. Altin, Ö. Göksu, R. Teodorescu og F. Iov, »Generic 12-Bus Test System for Wind Power Integration Studies,« i *EPE Joint Wind Energy and T&D Chapters Seminar*, Aalborg, Denmark, 2012.
- [7] B. P. a. B. Chaudhuri, *Robust Control in Power Systems*, December 2010: Springer.
- [8] T. R. ENTSO-E, Analysis of CE inter-area oscillations of 19 and 24 february 2011, ENTSO-E, August 2011.
- [9] N. M. a. D. T. K. Prasertwong, »Understanding low-frequency oscillation in power systems,« *International Journal of Electrical Engineering Education*, årg. 47, nr. 3, pp. 248–262, 2010.

Appendix

Formatted: Normal