



Method for determining a deadzone angle of a backlash in a mechanical drive-train system, method for controlling a drive motor controller as well as drive-train system

Papageorgious, Dimitrios; Blanke, Mogens; Niemann, Hans Henrik; Richter, Jan H.

Publication date:
2018

Document Version
Publisher's PDF, also known as Version of record

[Link back to DTU Orbit](#)

Citation (APA):
Papageorgious, D., Blanke, M., Niemann, H. H., & Richter, J. H. (2018). IPC No. B25J9/16; G05B19/404. Method for determining a deadzone angle of a backlash in a mechanical drive-train system, method for controlling a drive motor controller as well as drive-train system (Patent No. WO2018077593 .)

General rights

Copyright and moral rights for the publications made accessible in the public portal are retained by the authors and/or other copyright owners and it is a condition of accessing publications that users recognise and abide by the legal requirements associated with these rights.

- Users may download and print one copy of any publication from the public portal for the purpose of private study or research.
- You may not further distribute the material or use it for any profit-making activity or commercial gain
- You may freely distribute the URL identifying the publication in the public portal

If you believe that this document breaches copyright please contact us providing details, and we will remove access to the work immediately and investigate your claim.



- (51) International Patent Classification:
G05B 19/404 (2006.01) *B2SJ 9/16* (2006.01)
- (21) International Application Number:
PCT/EP20 17/075476
- (22) International Filing Date:
06 October 2017 (06.10.2017)
- (25) Filing Language: English
- (26) Publication Language: English
- (30) Priority Data:
16195975.4 27 October 2016 (27.10.2016) EP
- (71) Applicants: **SIEMENS AKTIENGESELLSCHAFT**
[DE/DE]; Werner-von-Siemens-StraBe 1, 80333 Munchen (DE). **TECHNICAL UNIVERSITY OF DENMARK**
[DK/DK]; Anker Engeldsvej 1, 2800 Kgs. Lyngby (DK).
- (72) Inventors: **PAPAGEORGIOUS, Dimitrios**; Dalgas Have 70 t.v, 2000 Frederiksberg (DK). **BLANKE, Mogens**;

Skovbakken 23, 3520 Farum (DK). **NIEMANN, Hans Henrik**; Isterod Byvej 4, 2970 Hoersholm (DK). **RICHTER, Jan**; Reichenberger Str. 18, 91207 Lauf a. d. Pegnitz (DE).

(74) Common Representative: **SIEMENS AKTIENGESEL-LSCHAFT**; Postfach 22 16 34, 80506 Munchen (DE).

(81) Designated States (*unless otherwise indicated, for every kind of national protection available*): AE, AG, AL, AM, AO, AT, AU, AZ, BA, BB, BG, BH, BN, BR, BW, BY, BZ, CA, CH, CL, CN, CO, CR, CU, CZ, DE, DJ, DK, DM, DO, DZ, EC, EE, EG, ES, FI, GB, GD, GE, GH, GM, GT, HN, HR, HU, ID, IL, IN, IR, IS, JO, JP, KE, KG, KH, KN, KP, KR, KW, KZ, LA, LC, LK, LR, LS, LU, LY, MA, MD, ME, MG, MK, MN, MW, MX, MY, MZ, NA, NG, NI, NO, NZ, OM, PA, PE, PG, PH, PL, PT, QA, RO, RS, RU, RW, SA, SC, SD, SE, SG, SK, SL, SM, ST, SV, SY, TH, TJ, TM, TN, TR, TT, TZ, UA, UG, US, UZ, VC, VN, ZA, ZM, ZW.

(54) Title: METHOD FOR DETERMINING A DEADZONE ANGLE OF A BACKLASH IN A MECHANICAL DRIVE-TRAIN SYSTEM, METHOD FOR CONTROLLING A DRIVE MOTOR CONTROLLER AS WELL AS DRIVE-TRAIN SYSTEM

FIG 4

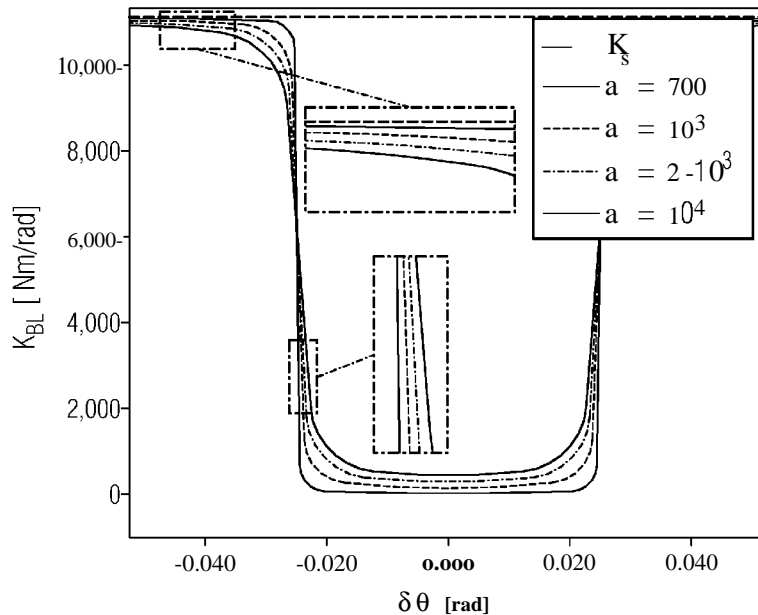

(57) Abstract: The invention relates to a method for determining a deadzone angle (ϵ) of a backlash in a mechanical drive-train system (1), wherein the drive train-system (1) comprises a drive motor (2), a load (3) and a shaft (4) for connecting the drive motor (2) with the load (3), the method comprising the steps: estimating an interconnection torque (T_I) in the deadzone, determining the deadzone angle (ϵ) depending on the interconnecting torque (T_I) by means of an adaptive estimator, wherein in the adaptive estimator the backlash is modelled in terms of a variable stiffness (K_{BL}) of the shaft (4).



(84) **Designated States** (*unless otherwise indicated, for every kind of regional protection available*): ARIPO (BW, GH, GM, KE, LR, LS, MW, MZ, NA, RW, SD, SL, ST, SZ, TZ, UG, ZM, ZW), Eurasian (AM, AZ, BY, KG, KZ, RU, TJ, TM), European (AL, AT, BE, BG, CH, CY, CZ, DE, DK, EE, ES, FI, FR, GB, GR, HR, HU, IE, IS, IT, LT, LU, LV, MC, MK, MT, NL, NO, PL, PT, RO, RS, SE, SI, SK, SM, TR), OAPI (BF, BJ, CF, CG, CI, CM, GA, GN, GQ, GW, KM, ML, MR, NE, SN, TD, TG).

Published:

— *with international search report (Art. 21(3))*

Description

Method for determining a deadzone angle of a backlash in a mechanical drive-train system, method for controlling a drive motor controller as well as drive-train system

The present invention relates to a method for determining a deadzone angle of a backlash in a mechanical drive-train system, wherein the drive-train system comprises a drive motor, a load and a shaft for connecting the drive motor with the load. Furthermore, the present invention relates to a method for controlling a drive motor of a drive train system. Moreover, the present invention relates to a controller for a drive-train system. Finally, the present invention relates to a drive train system.

Backlash is a common positioning-degrading phenomenon that shows up frequently in industrial machines. High-performance machine tools use backlash compensation algorithms to ensure accurate positioning of the tool. As such, estimation of the developing deadzones in gearing and other power transmission components is essential.

Developing backlash in coupling equipment due to wear is one of the main reasons for performance degradation in machine tool systems. Since high precision tool positioning is fundamental for obtaining the required quality of the machined end-products, backlash compensation solutions are used in nearly all modern Computer Numerical Control (CNC) algorithms. This necessitates the knowledge of the backlash offset angle in advance so that it can be used in the position controllers actuating the machine axes' motors. Under this prism, online estimation method may facilitate an automatic compensation solution for developing backlash. A substantial amount of research has been conducted on estimation of the backlash phenomenon for various systems over the past three decades. For example, the backlash in a gearing system can indirectly estimated by calculating the

bounce, i.e. the change of the speed of the driving part of the gear due to the backlash impact upon exiting the deadzone. Extended Kalman Filter (EKF) are used for estimating the backlash torque in a two-mass motor arm, based
5 on torque and position measurements. The modelling of the backlash torque using a differentiable function is known, where a nonlinear observer is used for estimation of the backlash amplitude. This method was also validated experimentally, wherein a sliding mode observer is used for
10 the estimation of the backlash torque. The backlash function parameters are identified offline based on this estimation. The effect of the deadband due to backlash in a closed loop motion system was studied using describing functions. Here, the functions parameters are calculated online using a static
15 relation for the controller gains. Backlash in automotive powertrains can be described based on the position difference between drive motor and load. Kalman filter is used for backlash estimation with 10% error. A four-parameter model for describing backlash effect for generic linear cascade
20 systems is also known. The backlash identification is treated as a quasi-linear problem using iterative algorithms. Minimization of a quadratic prediction error is known using position, velocity and torque measurements for offline identification of backlash torques in a vehicle driveline
25 system.

In the previous approaches, the backlash phenomenon is described in terms of the resulting torque upon contact of the two moving parts of the coupling. In the cases where the
30 deadzone angle is identified directly, this is done offline or around a linearization point of the system. The results show accuracy that prohibits the use of the estimates in any backlash compensation algorithms for systems where high precision is required.

35

It is an object of the present invention to provide a solution, how a deadzone angle in a drive-train system can be estimated in a more reliable manner.

According to the invention this object is solved by a method for determining a deadzone angle, by a method for controlling a drive motor, by a controller and by a drive-train system
5 having the features according to the respective independent claims. Advantageous embodiments of the invention are the subject matter of the dependent claims.

A method according to the invention serves for determining a
10 deadzone angle of a backlash in a mechanical drive-train system, wherein the drive train-system comprises a drive motor, a load and a shaft for connecting the drive motor with the load. The method comprising the steps: estimating an interconnection torque in the deadzone and determining the
15 deadzone angle depending on the interconnecting torque by means of an adaptive estimator, wherein in the adaptive estimator the backlash is modelled in terms of a variable stiffness of the shaft.

20 Backlash shows up as the loss of engagement between the motor and the load due to the developing deadzone or gap in the coupling mechanism. A certain amount of backlash is required in mating gears in order to compensate for any thermal expansion, allow the incorporation of lubricants and
25 compensate for any potential tolerances as regards installation inaccuracies. In particular, the clearance between the non-working flanks of a gear pair is referred to as the backlash. It is formed when the load flanks are touching. Backlash can describe the loss of engagement
30 between the motor and the load. The interconnecting torque can be the torque of the load. Here, the deadzone angle is determined by means of an adaptive estimator, wherein in the adaptive estimator the backlash is modelled in terms of a variable stiffness of the shaft. In comparison to known
35 deadzone models, in which the interconnecting torque is zero inside the deadzone and has a predetermined value outside the deadzone, the backlash can be estimated in a more reliable

manner. Furthermore, the method can be performed during operation of the drive-train system.

Preferably, the interconnecting torque is determined
5 depending on the load velocity. The velocity of the load and
in particular the angular velocity of the load can be
measured. Therefore, the interconnecting torque can
determined in a simple manner. Furthermore, the angular
position of the load and the load or backlash friction can be
10 measured. Moreover, the angular velocity and/or the angular
position of the motor can be measured.

According to a further embodiment, depending on the load
velocity, a load inertia and a load friction an error is
15 determined and the interconnection torque is determined based
on the error. Depending on the load velocity the dynamic of a
state estimation error can be determined. Here, an injection
signal can be determined, which reaches a sliding manifold
and remains thereafter.

20
It is further advantageous, if the interconnecting torque is
determined by means of a sliding mode observer. Preferably, a
second-order sliding mode observer (SMO) is used. In
particular, a super-twisting sliding mode observer (STSMO) is
25 used for estimating the backlash torque. This value is used
in an adaptive estimator design for finding the deadzone
angle .

According to a further embodiment, the deadzone angle is
30 determined by means of an adaptive estimator. For the
estimation of the deadzone angle is based on a method for
parameter estimation in nonlinearity parameterized systems.
This method is presented in H. F. Grip, T. A. Johansen, L.
Imsland, and G.-o. Kaasa: "Parameter estimation and
35 compensation in systems with nonlinearly parameterized
perturbations" Automatica, vol. 46, no. 1, pp. 19-28, 2010.
The basic idea relates to estimating a perturbation of the
system dynamics that depends on the unknown parameter and

then finding an adaptation law for estimating the parameter itself.

5 According to a further embodiment, the variable stiffness is modelled depending on a predetermined function. For example, a function can be used, which is based on an arctan-function. This function can include a parameter to adapt the slope for the change in the stiffness.

10 A further method according to the invention serves for controlling a drive motor of mechanical drive-train system, wherein the drive motor is controlled depending on the deadzone angle, which is determined by means of a method for determining the deadzone angle.

15 A controller according to the invention for a mechanical drive-train system is adapted for performing a method for determining the deadzone angle and/or a method for controlling the drive motor.

20 A drive-train system according to the invention comprises a controller according to the invention. Preferably, the drive-train system is a single axis mechanical drive-train system.

25 The preferred embodiments presented with respect to the method for determining the deadzone angle according to the invention and the advantages thereof correspondingly apply to the method for controlling the drive motor according to the invention, to the controller according to the invention as
30 well as to the drive-train system according to the invention.

Further features of the invention are apparent from the claims, the figures and the description of figures. The features and feature combinations mentioned above in the
35 description as well as the features and feature combinations mentioned below in the description of figures and/or shown in the figures alone are usable not only in the respectively

specified combination, but also in other combinations or alone without departing from the scope of the invention

Now, the invention is explained in more detail based on preferred embodiments as well as with reference to the attached drawings .

These show in:

- 10 FIG 1 in a schematic drawing, a drive-train system comprising a drive motor, a shaft and a load;
- FIG 2 a block diagram of an open-loop mechanical drive train system;
- 15 FIG 3 in a schematic drawing a deadzone angle of a backlash between a drive motor and the load;
- FIG 4 a stiffness of the shaft varying between two values ;
- 20 FIG 5 a backlash torque using a deadzone model and a varying stiffness model;
- 25 FIG 6 a real and an estimated backlash torque scaled by a load inertia;
- FIG 7 a real and an estimated change of a deadzone angle; and
- 30 FIG 8 an estimation error of the deadzone angle.

In the figures, identical or functionally identical elements are provided with the same reference characters.

35

FIG 1 shows a drive-train system 1 that comprises a drive motor 2, a load 3 and a shaft 4. The drive-train system 1 is designed as a single axis drive train system. The angular

velocities of the motor 2 and the load a denoted by ω_m , ω_l , respectively, while v_T is the tool linear velocity. The box 5 describes the gearing and shaft dynamics and the box 6 describes the linear axis dynamics.

5

A typical single-axis machine tool consists of a linear axis, which positions the tool on a line. The axis is actuated by the drive motor 2, which is typically connected to an angular-to-linear motion conversion system (e.g. a ball-screw axis). The combined elasticity, friction, damping and total mass of all the mechanical components that connect to the drive shaft 4 motivate a collective description of the single-axis machine tool as a mechanical drive train. The latter consists of the drive motor 2, one flexible shaft 4 with damping and backlash and a generalised load 3 with friction. The correspondence between the single-axis machine tool and the abstraction of the mechanical drive-train can be seen in FIG 1.

The drive motor 2 can be a permanent magnet synchronous motor (PMSM), typically used for actuating linear axes in machine tools, especially for highly dynamic tasks. The motor is position-controlled with a controller 7. The controller 7 can comprise a cascade of a proportional (P) and a proportional-integral (PI) controller, used for the position and the velocity loops, respectively.

In general, the electrical closed-loop dynamics is much faster than this the mechanical system. Moreover, since the focus of this work is on the identification of backlash, i.e. on the level of the accelerations, and since the torque produced by the motor 2 is measured, the closed-loop electrical dynamics of the motor will not be considered here. This does not affect the design or the estimation algorithms as it will become clearer later in the analysis.

35

The dynamics of the mechanical drive-train system 1 reads:

$$\dot{\omega}_m = \frac{1}{J_m} u - \frac{1}{J_m} T_{F,m} - \frac{1}{NJ_m} T_l \quad (1)$$

$$\dot{\theta}_m = \omega_m \quad (2)$$

$$\dot{\omega}_l = \frac{1}{J_l} T_{F,l} + \frac{1}{J_l} T_l \quad (3)$$

$$\dot{\theta}_l = \omega_l \quad (4)$$

5

ω_m is the motor angular velocity, θ_m is the motor angular position, ω_l is the load angular velocity and θ_l is the load angular position, u is the torque command, $T_{F,m}$ is the motor friction, $T_{F,l}$ is the load friction or the backlash friction and T_l is the load torque. J_m is the motor inertia, J_l is the load inertia and N is the gearing ratio.

10

In the backlash-free case an interconnection torque or load torque T_l is given from:

15

$$T_l = K_s \left(\frac{1}{N} \theta_m - \theta_l \right) + D_s \left(\frac{1}{N} \omega_m - \omega_l \right) \quad (5)$$

20

K_s is the shaft stiffness, D_s is the shaft damping coefficient. K_s , D_s and N and are assumed to be known. The friction torques acting on the drive motor and the load express different frictional phenomena. $T_{F,m}$ comes mostly from the contacting surfaces of the motor bearings while $T_{F,l}$ describes the total Coulomb and viscous friction in the load. The two friction torques are modelled as described in the following equations:

25

$$T_{F,m} = T_{C,m} \text{sgn}(\omega_m) + \beta_m \omega_m \quad (6)$$

$$T_{F,l} = T_{C,l} \text{sgn}(\omega_l) + \beta_l \omega_l \quad (7)$$

30

$T_{C,m}$ is the Coulomb friction on the motor and $T_{C,l}$ is the Coulomb friction on the load. β_m is the motor viscous friction coefficient and β_l is the load viscous friction coefficient. $T_{C,m}$, $T_{C,l}$, β_m and β_l are considered known and constant. $\text{sgn}(\cdot)$ is the signum function defined as:

35

$$\text{sgn}(\xi) = \begin{cases} 1 & \text{if } \xi > 0 \\ 0 & \text{if } \xi = 0 \\ -1 & \text{if } \xi < 0 \end{cases}$$

FIG 2 illustrates a block diagram of the drive-train system in open loop. The block labelled "DZ" represents the backlash zone .

5

Backlash shows up as a loss of engagement between two moving parts (e.g. motor 2 and load 3) due to a developing gap (deadzone) in the coupling mechanisms as shown in FIG 3 .

10 Alternatively, the backlash phenomenon can be interpreted as either a sudden change in the load inertia or even in the shaft stiffness. In general, the backlash torque is modelled after the restoring and damping torques in a mass-spring-damper system. While in the deadzone, these two torques are
15 either vanishing or becoming very small, nearly zero. A number of studies have been carried out regarding the description of the torques due to backlash. The most intuitive and common one is the so-called deadzone model, in which the interconnection torque T_l becomes zero inside the
20 deadzone. Outside the deadzone the angle difference is offset by the width of the deadzone angle δ . An approach is known, where the ratio of the angle differences over the deadzone width is considered. Dynamical models are known, which pertain to expressing the backlash torque as a sudden impact.
25 The torque is again given by a mass-spring-damper system, where the elastic linear relative deformation of the two colliding coupling parts has its own stiff dynamics. A different dynamical model is known, in which a backlash angle δ is defined and its dynamics is used for calculating the
30 impact torque. Most of the above-mentioned backlash models are effectively describing the phenomenon but they typically become difficult to use for control and estimation purposes due to their heavy discontinuities that often create numerical issues. This problem becomes even more apparent for
35 non-constant deadzone, i.e. when the backlash angle δ increases over time due to wear.

A model for backlash, based on changing shaft stiffness, which is suitable for deadzone estimation and monitoring will be presented and will be compared to the deadzone model.

5 Defining the angular position and velocity difference between drive motor and load as:

$$\Delta\theta \triangleq \frac{1}{N}\theta_m - \theta_l \quad (9)$$

$$\Delta\omega \triangleq \frac{1}{N}\omega_m - \omega_l \quad (10)$$

10

The interconnection torque T_l in the deadzone model is given by:

$$T_l^{DZ} = \begin{cases} K_S(\Delta\theta - \delta \cdot \text{sgn}(\Delta\theta)) + D_S\Delta\omega & \text{if } |\Delta\theta| > \delta \\ 0 & \text{if } |\Delta\theta| \leq \delta \end{cases} \quad (11)$$

15

The proposed model is based on a factorization of the backlash torque with respect to the shaft stiffness. The latter is very small, virtually zero, inside the deadzone and assumes its nominal value outside of it. The transition
20 between the two extreme values of the stiffness is steep but smooth. The corresponding torque reads:

$$T_l = \left[\Delta\theta - \delta \cdot \text{sgn}(\Delta\theta) + \frac{D_S}{K_S}\Delta\omega \right] \cdot K_{BL}(\Delta\theta, \delta) \quad (12)$$

$$K_{BL} = \frac{K_S}{\pi} \left[\pi + \arctan(\alpha(\Delta\theta - \delta)) - \arctan(\alpha(\Delta\theta + \delta)) \right] \quad (13)$$

25

\mathbf{a} is a large positive real number that parametrizes how stiff the change in the stiffness is. For $\alpha \rightarrow \infty$, it is clear that $T_l \rightarrow T_l^{DZ}$. This can also be seen in FIG 4, where the stiffness $K_{BL}(\Delta\theta, \delta)$ and the corresponding backlash torques are
30 plotted for different values of the parameter \mathbf{a} . FIG 5 shows the backlash torque T_l^{DZ} , T_l for a sinusoidal $\Delta\theta$ using a deadzone model and the varying stiffness models for different values of the parameter \mathbf{a} .

35 Here, the deadzone angle δ should be estimation for drive-train system 1. This can be summarised in the following

problem formulation: Given the single-axis drive-train system described in equations (1) to (7) and the backlash model in equations (12) and (13), design an online dynamic estimator for the deadzone angle δ with the following requirements:

- 5 Maximum estimation error smaller than 10^{-3} rad and asymptotic convergence to the real parameter value.

The estimation of the deadzone angle δ belongs to the family of problems of online parameter estimation in systems with
 10 nonlinear parametrization . The approach followed here is based on a method for parameter estimation in nonlinearly parametrized systems presented in H. F. Grip, T. A. Johansen, L. Imsland, and G.-o. Kaasa: "Parameter estimation and compensation in systems with nonlinearly parameterized
 15 perturbations" Automatica, vol. 46, no. 1, pp. 19-28, 2010. The basic idea relates to estimating a perturbation of the system dynamics that depends on the unknown parameter and then finding an adaptation law for estimating the parameter itself .

20

The system dynamics is described by:

$$\dot{x} = f(t, x) + g(t, x)[u(t, x) + d(t, x, \delta)] \quad (14)$$

25 where $x \in \mathbb{R}^n$ is measured, $f: \mathbb{R}_{\geq 0} \times \mathbb{R}^n \rightarrow \mathbb{R}^n$ and $g: \mathbb{R}_{\geq 0} \times \mathbb{R}^n \rightarrow \mathbb{R}^{n \times m}$ are the unforced system dynamics and time-varying input gain, respectively, which can be evaluated from the measurements. $\delta \in \mathcal{D} \subset \mathbb{R}$ is the unknown parameter, $u \in \mathbb{R}^m$ is the control input and $d: \mathbb{R}_{\geq 0} \times \mathbb{R}^n \times \mathcal{D} \rightarrow \mathbb{R}^m$ is a known matched disturbance vector,
 30 which can be evaluated if δ is known. The method pertains to finding an estimation $\hat{\phi}$ of the perturbation

$$\phi \triangleq g(t, x)d(t, x, \delta) \quad (15)$$

35 and then derive an adaptation law

$$\dot{\hat{\delta}} = \rho(t, x, \hat{\phi}, \hat{\delta}) \quad (16)$$

for estimating the unknown parameter.

Regarding the drive-train system 1, since all the states are measured and the unknown parameter δ affects the dynamics of both the motor and the load in the same way, i.e. through the torque T_{lr} either of the subsystems in equations (1), (3) can be chosen to apply the method on. For simplicity, the load velocity dynamics is chosen. The system can be written in the form of equation (14) with $f(\omega_l) = \frac{1}{J_l} T_{F,l}$, $g = \frac{1}{J_l}$ and $d(x, \delta) = T_l$, where T_l has been defined in equations (12), (13) and $x \triangleq [\omega_m \theta_m \omega_l \theta_l]^T$ is the state vector of the drive-train system 1. The method is divided in two parts: estimation of the perturbation ϕ and derivation of the adaptation law $\rho(x, \hat{\phi}, \hat{\delta})$.

A second-order sliding mode observer (SMO) is used for finding an estimate of ϕ . In general SMOs can offer finite-time estimation of unmeasured states by using high-frequency injection signals in their design, which depend on the observer innovation term. By doing so, the estimation error dynamics reaches the sliding manifold, i.e. a manifold on which the error is zero, and remains thereafter. This provides at the same time an estimation of any unknown perturbations that affect the system dynamics. This can become clearer in the following:

The load velocity dynamics presented in equation (3) and a SMO given by

$$\dot{\hat{\omega}}_l = -\frac{1}{J_l} T_{F,l} + v(\tilde{\omega}_l) \quad (17)$$

are considered, wherein $\tilde{\omega}_l = \omega_l - \hat{\omega}_l$ is the state estimation error and v is an appropriate high frequency term depending on the innovation signal $\tilde{\omega}_l$. Define the sliding manifold $S = \{\tilde{\omega}_l \in \mathbb{R}: \tilde{\omega}_l = \dot{\tilde{\omega}}_l = 0\}$. The estimation of the state estimation error reads :

$$\dot{\tilde{\omega}}_l = \dot{\omega}_l - \dot{\hat{\omega}}_l = \frac{1}{J_l} T_l - v \quad (18)$$

If the error dynamics reach the sliding manifold, then $\dot{\tilde{\omega}}_l = 0$ for all future times, which means that $v = \frac{1}{J_l} T_l$. In other words, if the injection signal \mathbf{v} is designed such that the estimation error dynamics reaches the sliding manifold S and remains thereafter, then the unknown perturbation $\phi = -\frac{1}{J_l} T_l$ is estimated by \mathbf{v} . The design of \mathbf{v} is given in:

$$v = k_1 |\tilde{\omega}_l|^{\frac{1}{2}} \text{sgn}(\tilde{\omega}_l) + k_2 \int_0^t \text{sgn}(\tilde{\omega}_l(\tau)) d\tau \quad (19)$$

10

where k_{1r} k_2 are positive gains. The resulting observer is called the STSMO and it was proven that for appropriate gains k_{1r} k_2 the term \mathbf{v} brings the observer error dynamics on the sliding manifold s . Hence, the unknown perturbation can be estimated by equation (19), where

15

$$\hat{\phi} = v \quad (20)$$

20

The choice of a second order SMO for a system of relative degree 1 (the subsystem is scalar) was made due to the property of higher order SMOs of alleviating the chattering in the injection and estimation signals.

25

The estimator design is inspired by the method proposed in Grip et al. for the estimation of unknown parameters. For the rest of the analysis it is considered that the unknown parameter $\mathbf{5}$ lies in a compact set $\mathcal{D} \subset \mathbb{R}$ and the backlash angle estimation error is defined as $\tilde{\delta} = \delta - \hat{\delta}$. For determining the backlash error angle estimator three assumptions and one theorem are used:

30

Assumption 1: There exists a piecewise continuous function $:\mathbb{R}^4 \rightarrow \mathbb{R}_{\geq 0}$ and a function $\mu: \mathbb{R}^4 \times \mathcal{D} \rightarrow \mathbb{R}$, both of them bounded for bounded state vector x , such that $\forall x \in \mathbb{R}$ and all pairs $\delta_1, \delta_2 \in \mathcal{D}$,

35

$$\mu(x, \delta_1) \frac{1}{J_l} \frac{\partial T_l}{\partial \delta}(x, \delta_2) \geq \sigma(x) \quad (21)$$

Assumption 2: There exists a positive real constant number $L > 0$ such that $\forall \delta_1, \delta_2 \in \mathcal{D}$,

$$5 \quad \frac{1}{J_l} |T_l(x, \delta) - T_l(x, \hat{\delta})| \leq L \sqrt{\sigma(x)} |\hat{\delta}| \quad (22)$$

Assumption 3: There exist positive real numbers T, ε such that $\forall t \in \mathbb{R}_{\geq 0}$,

$$10 \quad \int_t^{t+T} \sigma(x(\tau)) d\tau \geq \varepsilon \quad (23)$$

Theorem 1: Consider the dynamics of the load velocity expressed in the form of equation (14) with $g = \frac{1}{J_l}$ and $\alpha(x, \delta) = T_l(x, \delta)$ defined in equations (11) and (13). The adaptive estimator

$$\dot{\hat{\delta}} = \rho(x, \hat{\phi}, \hat{\delta}) = Proj \left[\hat{\delta}, \gamma \mu(x, \hat{\delta}) \left(\hat{\phi} - \frac{1}{J_l} T_l(x, \hat{\delta}) \right) \right] \quad (24)$$

with $\gamma > 0$ being the adaptation gain, $\hat{\phi}$ an asymptotic estimate of $\frac{1}{J_l} T_l$ and $Proj(\dots)$ the projection operator defined in V-A, ensures that the estimation error $\tilde{\delta}$ asymptotically converges to 0, uniformly in x if assumptions 1 to 3 are satisfied.

25 Inspired by Grid et al. and assuming constant deadzone angle δ , the dynamics of the parameter estimation error can be written as

$$\dot{\tilde{\delta}} = \dot{\delta} - \dot{\hat{\delta}} = -Proj \left[\hat{\delta}, \gamma \mu(x, \hat{\delta}) \left(\hat{\phi} - \frac{1}{J_l} T_l(x, \hat{\delta}) \right) \right] \quad (25)$$

30 Substituting the asymptotic estimate $\hat{\phi}$ with the real perturbation ϕ in (25) yields

$$\dot{\tilde{\delta}} = -Proj \left[\hat{\delta}, \gamma \mu(x, \hat{\delta}) \frac{1}{J_l} (T_l(x, \delta) - T_l(x, \hat{\delta})) \right] \quad (26)$$

35 In the following the shortened notation will be used

$$\begin{aligned}\mu &\triangleq \mu(x, \hat{\delta}) \\ \hat{T}_l &\triangleq T_l(x, \hat{\delta})\end{aligned}$$

5 The Lyapunov function candidate is defined as

$$V(t, \tilde{\delta}) = \frac{1}{2} \left(\frac{1}{\gamma} - \kappa \int_t^\infty e^{(t-\tau)} \sigma(x(\tau)) d\tau \right) \tilde{\delta}^2 \quad (27)$$

where κ is a real positive number to be defined. The function
10 is positive definite since

$$\left(\frac{1}{\gamma} - \kappa \sup_{x \in \mathbb{R}} \sigma(x) \right) |\tilde{\delta}|^2 \leq V(t, \tilde{\delta}) \leq \frac{1}{\gamma} |\tilde{\delta}|^2 \quad \text{for } \kappa < \frac{1}{\gamma \sup_{x \in \mathbb{R}} \sigma(x)}.$$

The time derivate of V along the trajectory of the
15 estimation error reads:

$$\begin{aligned}\dot{V}(t, \tilde{\delta}) &= \frac{\partial V}{\partial t}(t, \tilde{\delta}) + \frac{\partial V}{\partial \tilde{\delta}}(t, \tilde{\delta}) \dot{\tilde{\delta}} = \\ &= \frac{1}{2} \tilde{\delta}^2 \frac{\partial}{\partial t} \left[-\kappa \int_t^\infty e^{(t-\tau)} \sigma(x(\tau)) d\tau \right] \\ &\quad - \tilde{\delta} \left(\frac{1}{\gamma} - \kappa \int_t^\infty e^{(t-\tau)} \sigma(x(\tau)) d\tau \right) \dot{\tilde{\delta}} = \\ &= \frac{\kappa}{2} \tilde{\delta}^2 \left[\frac{\partial}{\partial t} \int_0^t e^{(t-\tau)} \sigma(x(\tau)) d\tau - \int_0^\infty \frac{\partial}{\partial t} e^{(t-\tau)} \sigma(x(\tau)) d\tau \right] \\ &\quad - \tilde{\delta} \frac{1}{\gamma} \text{Proj} \left[\hat{\delta}, \gamma \mu \cdot \frac{1}{J_l} (T_l - \hat{T}_l) \right] \\ &\quad + \tilde{\delta} \kappa \int_t^\infty e^{(t-\tau)} \sigma(x(\tau)) d\tau \cdot \text{Proj} \left[\hat{\delta}, \gamma \mu \cdot \frac{1}{J_l} (T_l - \hat{T}_l) \right] \quad (28)\end{aligned}$$

Using the property

20

$$-\tilde{\delta} \frac{1}{\gamma} \text{Proj} \left[\hat{\delta}, \gamma \mu \cdot \frac{1}{J_l} (T_l - \hat{T}_l) \right] \leq -\hat{\delta}, \gamma \mu \cdot \frac{1}{J_l} (T_l - \hat{T}_l)$$

as well as the property

$$\int_0^\infty e^{(t-\tau)} \sigma(x(\tau)) d\tau \geq e^{-T} \int_t^{t+T} \sigma(x(\tau)) d\tau, \tau > 0$$

25 equation (28) gives

$$\dot{V}(t, \delta) = \frac{\kappa}{2} \delta^2 \left(\sigma(x) - e^{-T} \int_t^{t+T} \sigma(x(\tau)) d\tau \right) - \delta \int_0^1 \mu \frac{1}{J_l} \frac{\partial T_l}{\partial \delta} (\delta + p\delta) \delta dp$$

Using assumptions 1 to 3 in the inequality above and introducing M , Σ as upper bounds for $|\mu(x, \delta)|$, $|\sigma(x)|$, respectively yields

5

$$\dot{V} \leq -\left(\mu - \frac{\kappa}{2}\right) \sigma(x) \delta^2 - \frac{\kappa}{2} \varepsilon e^{-T} \delta^2 + \kappa \frac{\gamma}{J_l} \cdot M \cdot \Sigma \sqrt{\sigma(x)} |\delta|^2 = -\psi^T Q \psi \quad (29)$$

where

$$\psi^T = [|\delta| \quad \sqrt{\sigma(x)} |\delta|]$$

$$Q = \begin{bmatrix} \frac{\kappa}{2} \varepsilon e^{-T} & -\frac{\kappa}{2J_l} \gamma \cdot M \cdot \Sigma \\ -\frac{\kappa}{2J_l} \gamma \cdot M \cdot \Sigma & \mu - \frac{\kappa}{2} \end{bmatrix}$$

10

From inequality (29) it can be seen that \dot{V} is negative definite if κ is chosen as

$$\kappa < \frac{2M}{\frac{e^T}{1 + \frac{2\varepsilon J_l^2 M^2 \Sigma^2 \gamma^2}{e^T}}} \quad (30)$$

15

and by Lasalle-Yoshizawa theorem the equilibrium point $\delta^* = 0$ is uniformly asymptotically stable, which completes the proof.

20 The final steps of the design concern satisfying assumptions 1 to 3. Selecting $\mu(x, \delta)$ as

$$\mu(x, \delta) = \frac{1}{K_S^2} \frac{\partial T_l}{\partial \delta} (x, \delta) \quad (31)$$

25 Condition (21) is satisfied with

$$\sigma(x) = \frac{1}{K_S^2} \left(\frac{\partial T_l}{\partial \delta} \right)^2 = \frac{1}{\pi^2} [\chi_1(x, \delta) + \chi_2(x, \delta)]^2 \quad (32)$$

where χ_1, χ_2 are defined as

$$\chi_1(x, \hat{\delta}) = \text{sgn}(\Delta\theta) \cdot \left[\pi + \arctan(\alpha(\Delta\theta - \hat{\delta})) - \arctan(\alpha(\Delta\theta + \hat{\delta})) \right] \quad (33)$$

5

$$\chi_2(x, \hat{\delta}) = \left[\Delta\theta - \hat{\delta} \cdot \text{sgn}(\Delta\theta) + \frac{D_S}{K_S} \Delta\omega \right] \cdot \left\{ \frac{\alpha}{1 + [\alpha(\Delta\theta - \hat{\delta})]^2} + \frac{\alpha}{1 + [\alpha(\Delta\theta + \hat{\delta})]^2} \right\} \quad (34)$$

Since x and $\sigma(x)$ are bounded and \mathcal{D} is compact, it is easy to show that there exists $L > 0$, such that condition (22) holds. The inequality $\int_t^{t+T} \sigma(x(\tau)) d\tau \geq \varepsilon$ expresses a type of persistence of excitation (PE) condition. From equations (32) to (34) it can be seen that this condition does not hold if during the time interval $[t, t + T]$ the system is always within the deadzone. This, however, is expected, since in that case there is no engagement between motor and load, hence no information about the stiffness of the shaft connecting them. The adaptation law for the parameter estimate $\hat{\delta}$ is finally given by:

$$\dot{\hat{\delta}} = \text{Proj} \left\{ \hat{\delta}, \gamma \frac{1}{K_S^2} \frac{\partial T_l}{\partial \delta}(x, \hat{\delta}) \left[\hat{\phi} - \frac{1}{J_l} T_l(x, \hat{\delta}) \right] \right\}, \gamma > 0 \quad (35)$$

where

$$\frac{\partial T_l}{\partial \delta}(x, \hat{\delta}) = \frac{K_S}{\pi} [\chi_1(x, \hat{\delta}) + \chi_2(x, \hat{\delta})] \quad (36)$$

25

It is interesting to note that the selection of the specific $\mu(x, \hat{\delta})$ function results into a gradient-type adaptation law, which is very common in the literature of adaptive techniques. Although for nonlinearly parametrized systems it does not always guarantee parameter convergence as it does for linear-in-the-parameters systems, it is a natural first choice for the adaptation law.

In the algorithm for the backlash angle estimation, $\omega_m, \theta_m, \theta_l, \theta_1$ and $T_{F,l}$ are measured. The output is the deadzone angle δ . In a first step, a STSMO for the load velocity is designed

35

according to equations (17) and (19) is designed. In a second step, the backlash torque according to equation (20) is estimated. In a third step, the adaptive estimator for the deadzone angle δ according to equations (33) to (36) is designed.

The drive-train system was simulated so that the performance of the estimation algorithm could be assessed. A PI controller is used to regulate the drive motor velocity into following a sinusoidal profile $\omega_m^{ref} = \Omega \sin(\nu t)$. A 5% change in the deadzone angle δ is considered for the evaluation of the algorithm. The velocity measurements are afflicted with white Gaussian noise $\omega \sim \mathcal{N}(0, \sigma_{meas}^2)$. High precision absolute position encoders are used and the error due to quantization is ignored. The compact set \mathcal{I} is the real axis interval $[0, 1]$, the estimator is initialized at $\hat{\delta}(0) = \delta_0$, γ is chosen to be 0.1 and the sampling time is 2 ms.

FIG 6 shows the real torque $J_l \phi$, $J_l \hat{\phi}$ applied in the system according to the deadzone model and its estimation by the STSMO. A small lag can be observed in the estimation of $\hat{\phi}$, which, however, does not affect the performance of the algorithm. Increasing the gains k_1, k_2 of the observer reduces the delay in estimation but makes the method more sensitive to measurement noise.

The real deadzone angle δ and estimated deadzone angle $\hat{\delta}$ as well as the estimation error $\tilde{\delta}$ are shown in FIG 7 and 8, respectively. It can be seen from the plots that the deadzone angle δ is estimated in less than 1 s (200-400 ms) and in sufficient accuracy. Specifically, the average steady state estimation error is less than $2 \cdot 10^{-6}$ rad, which is smaller than the order of magnitude for positioning precision in machine tool applications (10^{-3} rad). Larger sensor noise has a direct impact on the speed of convergence and the steady state deviation.

A method for deadzone angle estimation in a single-axis drive-train with backlash has been presented. After the interconnecting torque acting on both motor and load is estimated using a STSMO, an adaptive algorithm is designed for estimating the deadzone angle δ . The method was tested in a simulation framework, where the adaptive estimator was able to track the real value of the deadzone angle δ , as well as a 5% increase in the backlash. The parameter convergence was achieved in less than 1 s and with precision in the order of $2 \cdot 10^{-6}$ rad. Such precision allows for use of the estimated parameter in backlash compensation algorithms, typically present in machine-tool applications. Moreover, detection of changes in the deadzone angle δ can infer a measure of wear assessment in the mechanical components (i.e. gearing, coupling mechanisms etc.) of the system.

Claims

1. Method for determining a deadzone angle (δ) of a backlash in a mechanical drive-train system (1), wherein the drive
5 train-system (1) comprises a drive motor (2), a load (3) and a shaft (4) for connecting the drive motor (2) with the load (3), the method comprising the steps:
- estimating an interconnection torque (T_l) in the deadzone,
 - determining the deadzone angle (δ) depending on the
10 interconnecting torque (T_l) by means of an adaptive estimator,
 - wherein in the adaptive estimator the backlash is modelled in terms of a variable stiffness (K_{BL}) of the shaft (4).
- 15 2. Method according to claim 1, characterized in that, the interconnecting torque (T_l) is determined depending on the angular load velocity (ω_l).
3. Method according to claim 2, characterized in that,
20 depending on the angular load velocity (ω_l), a load inertia (J_l) and a load friction (T_{Fii}) an error is determined and the interconnection torque (T_l) is determined based on the error.
4. Method according to 2 or 3, characterized in that, the
25 interconnecting torque (T_l) is determined by means of a sliding mode observer.
5. Method according to any one of the preceding claims, characterized in that, the deadzone angle (δ) is determined
30 by means of an adaptive estimator.
6. Method according to any one of the preceding claims, characterized in that, the variable stiffness (K_{BL}) is modelled depending on a predetermined function.
- 35 7. Method for controlling a drive motor (2) of drive-train system (1), wherein the drive motor (2) is controlled

depending on the deadzone angle (δ), which is determined by means of a method according to claims 1 to 6.

8. Controller (7) for a mechanical drive-train system (1),
5 which is adapted for performing a method according to claims 1 to 6 and/or a method according to claim 7.

9. Drive-train system (1) comprising a controller (7)
according to claim 8.

10

10. Drive-train system (1) according to claim 9,
characterized in that, the drive-train system (1) is a single
axis mechanical drive-train system.

FIG 1

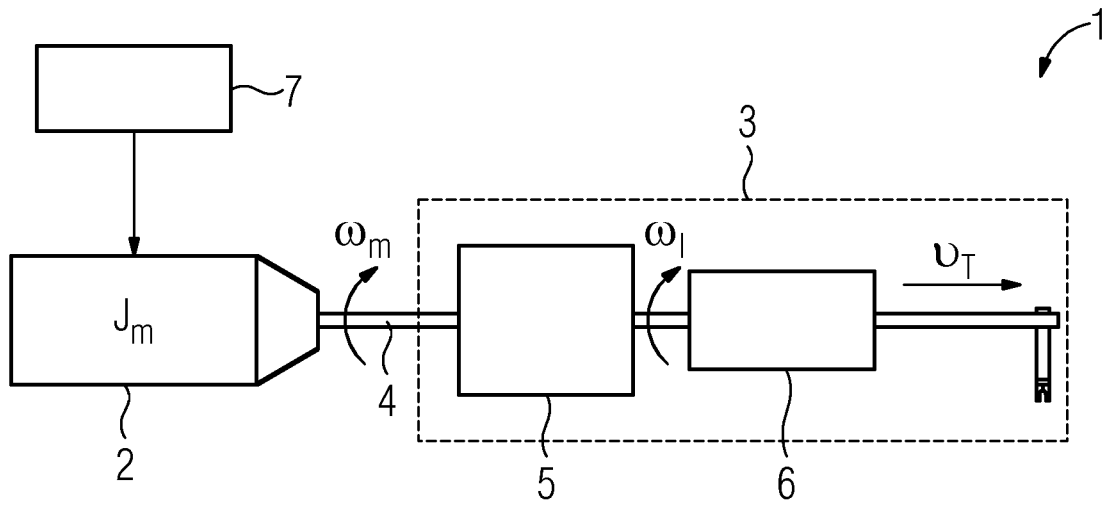

FIG 2

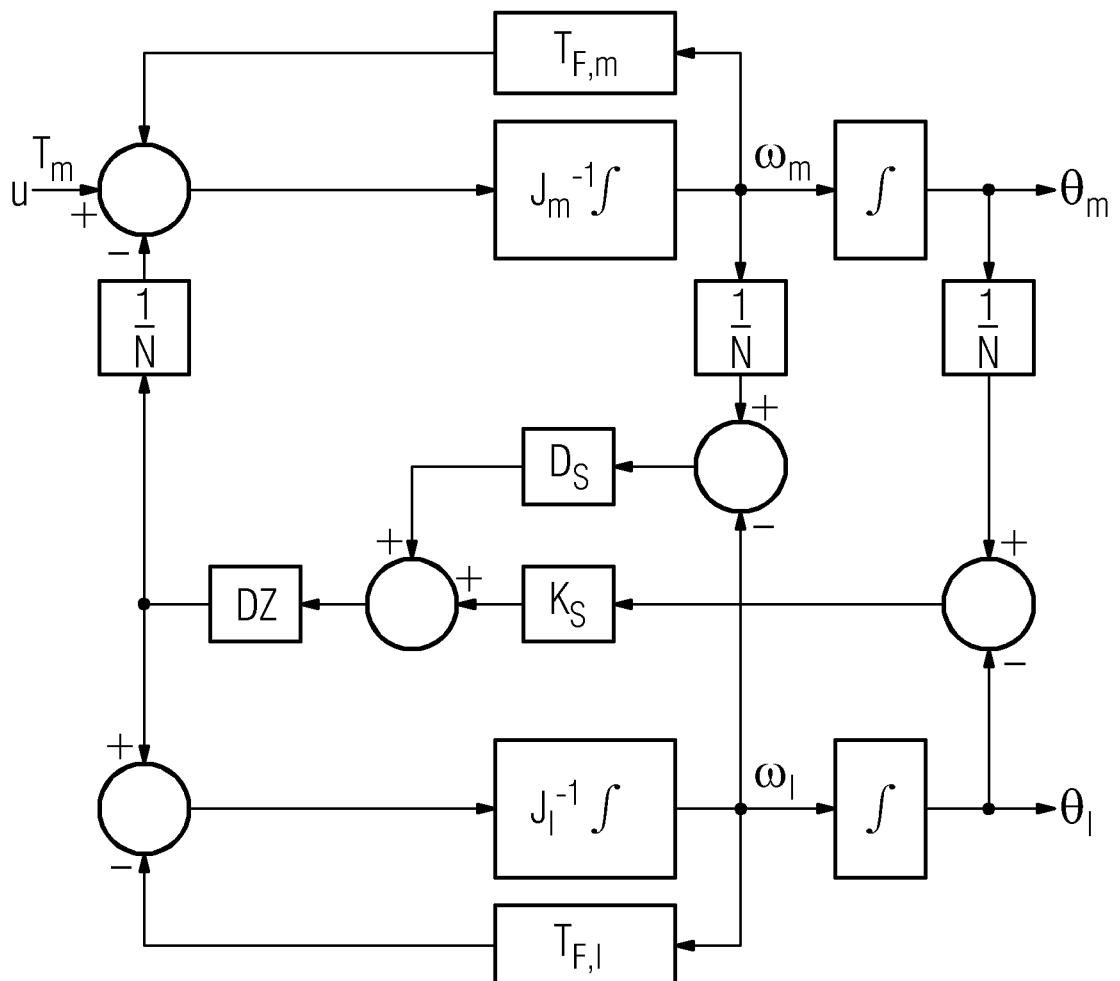

FIG 3

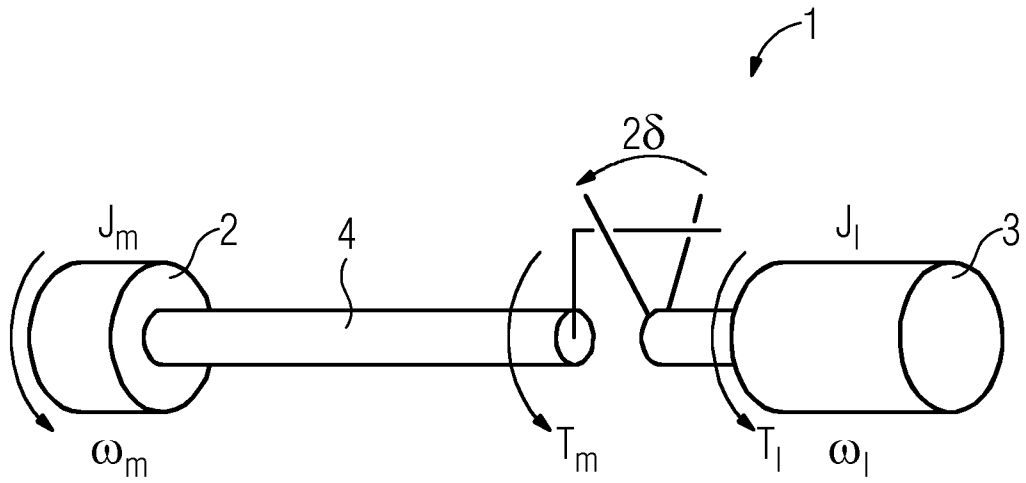

FIG 4

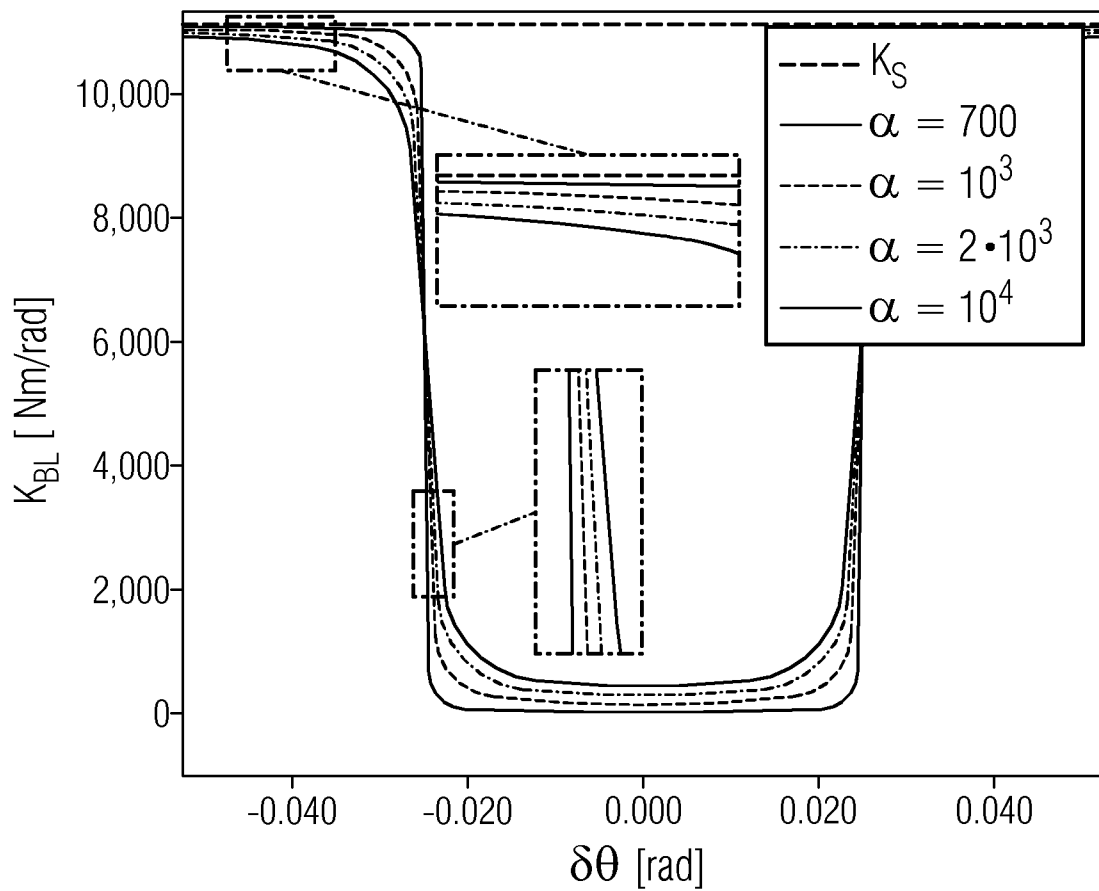

FIG 5

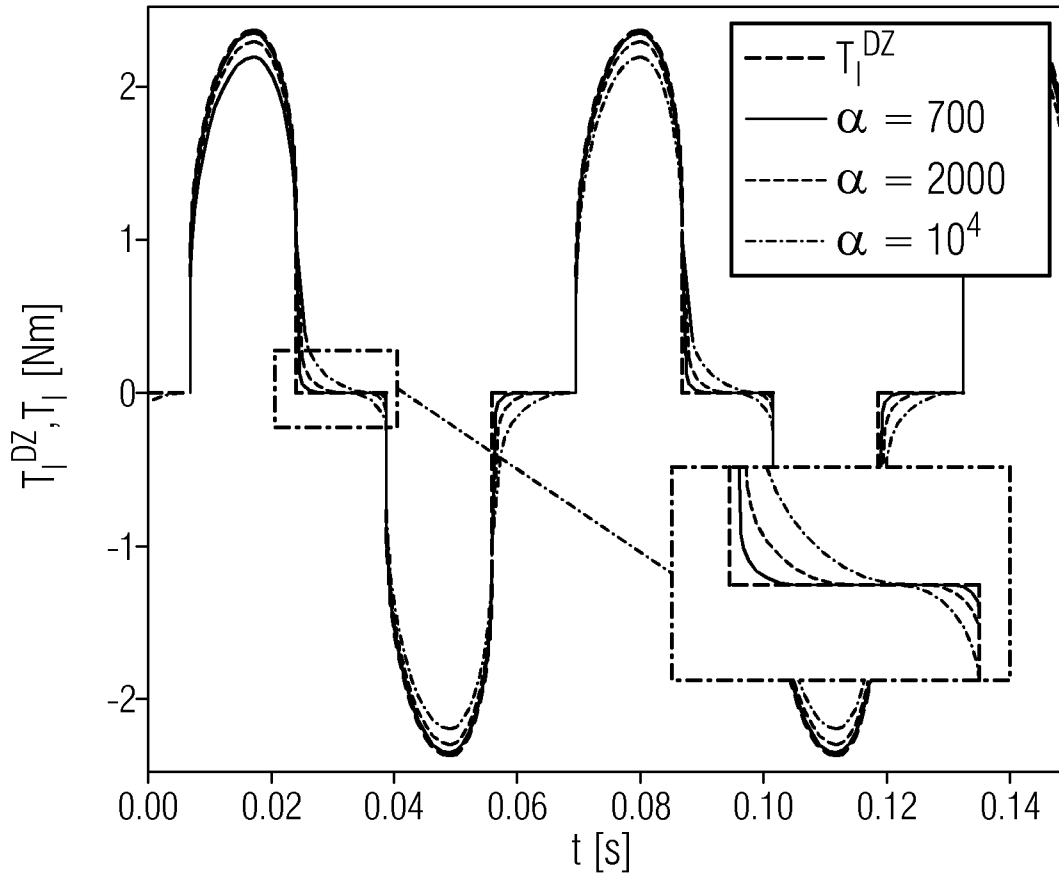

FIG 6

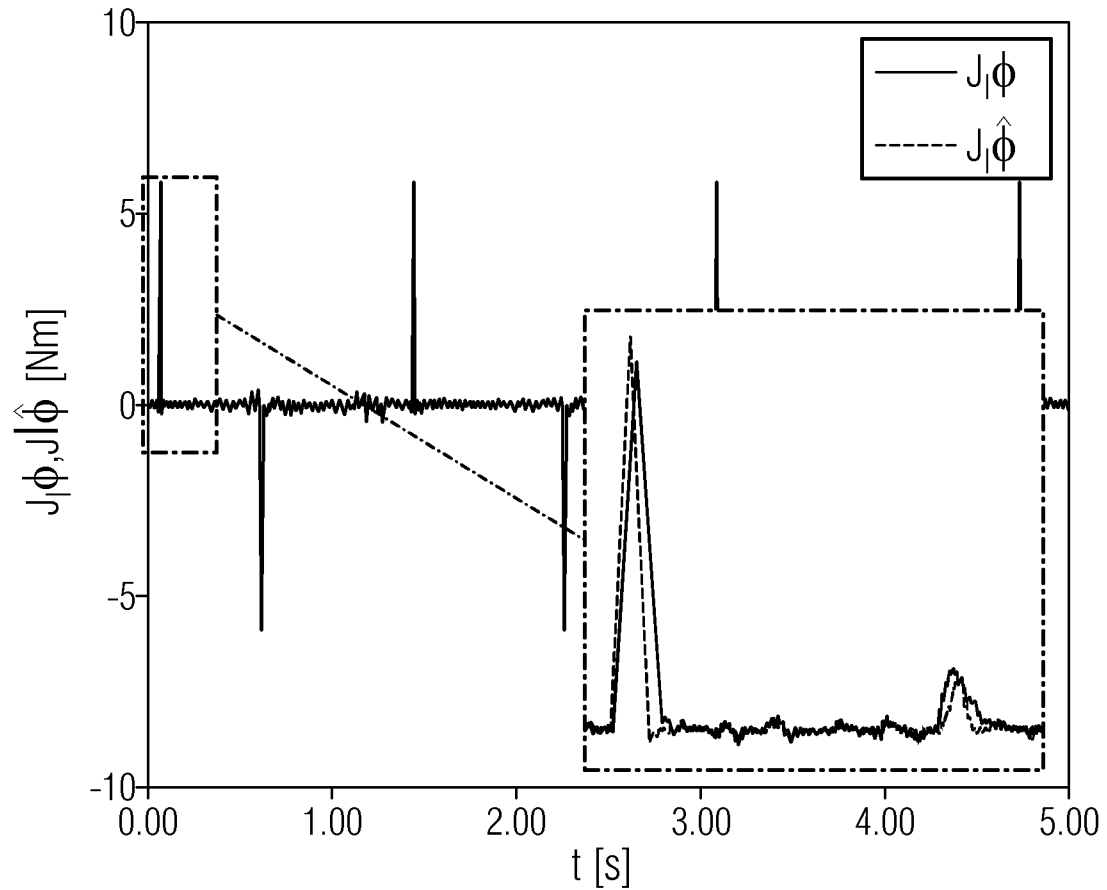

FIG 7

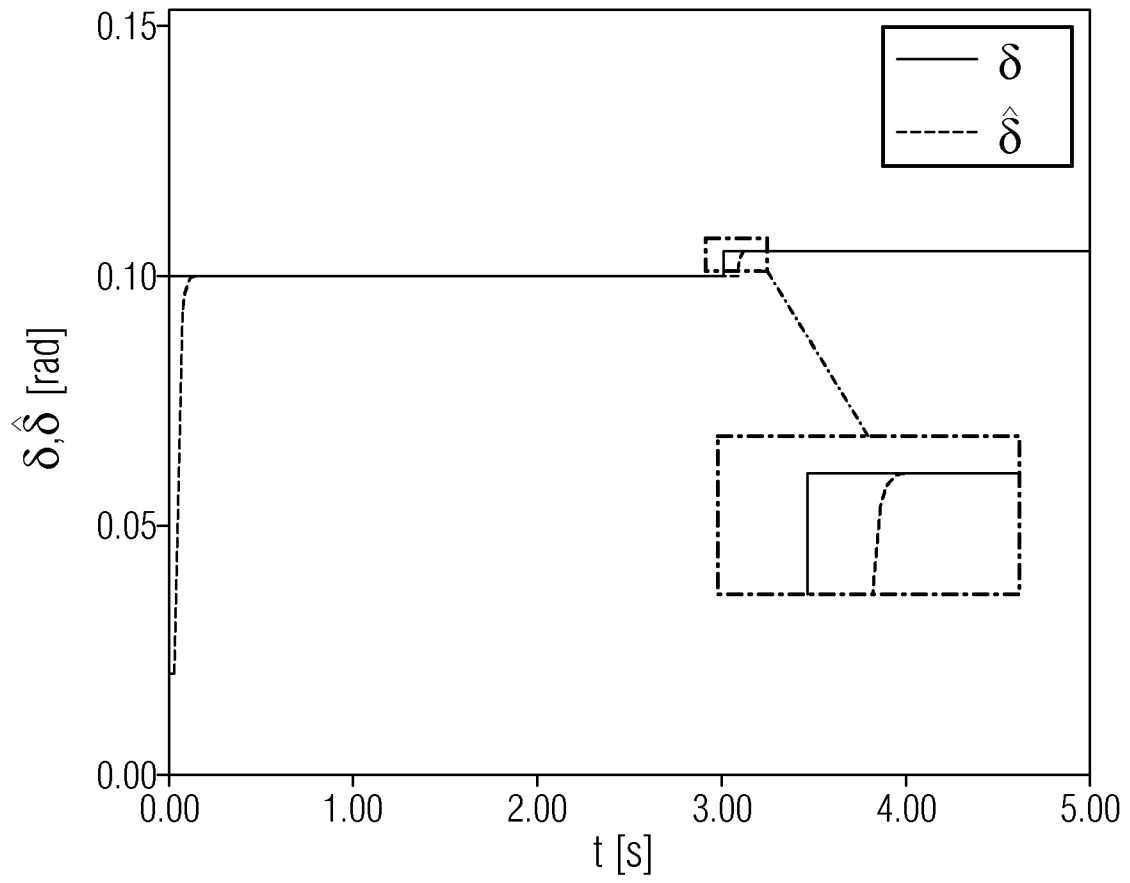
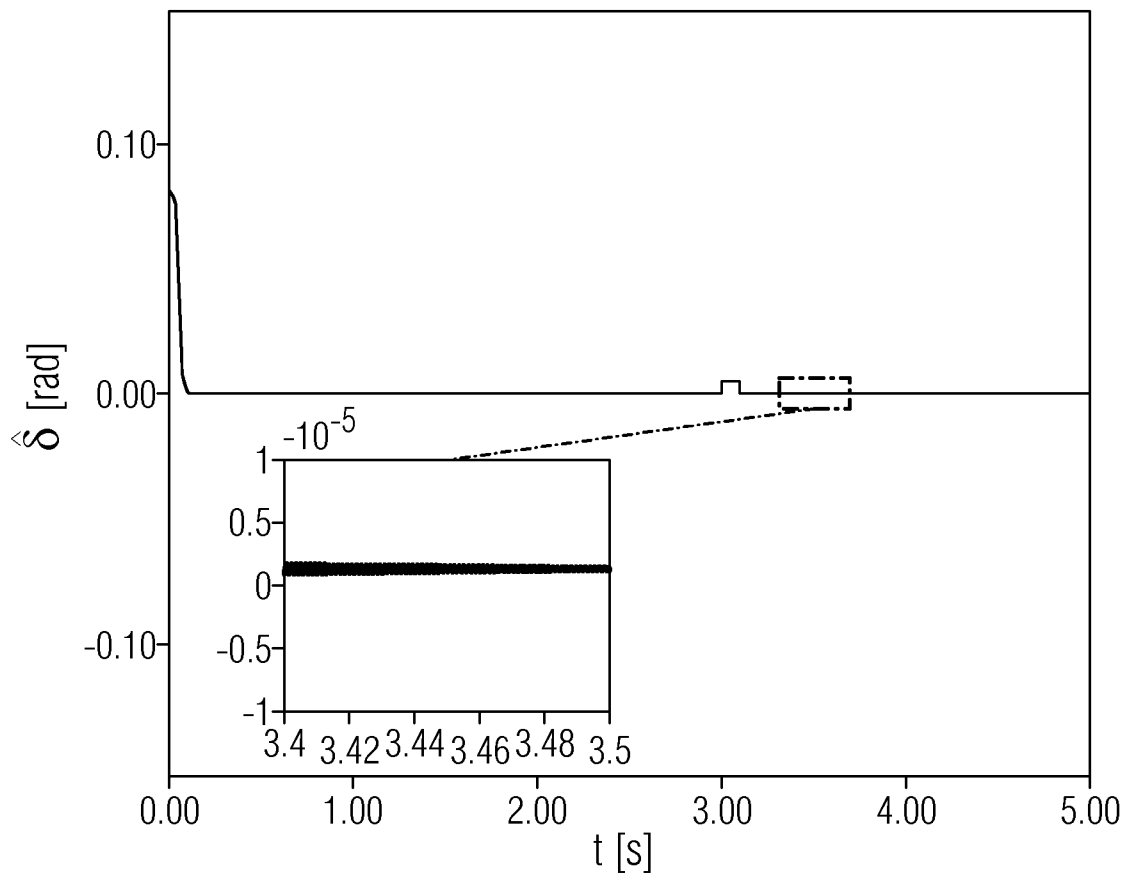

FIG 8



INTERNATIONAL SEARCH REPORT

International application No
PCT/EP2017/075476

A. CLASSIFICATION OF SUBJECT MATTER
 INV. G05B19/404 B25J9/16
 ADD.
 According to International Patent Classification (IPC) or to both national classification and IPC

B. FIELDS SEARCHED
 Minimum documentation searched (classification system followed by classification symbols)
 G05B B25J

Documentation searched other than minimum documentation to the extent that such documents are included in the fields searched

Electronic data base consulted during the international search (name of data base and, where practicable, search terms used)
 EPO-Internal , WPI Data

C. DOCUMENTS CONSIDERED TO BE RELEVANT

Category*	Citation of document, with indication, where appropriate, of the relevant passages	Relevant to claim No.
Y	LAGERBERG A ET AL: "Estimati on of backl ash with appl icati on to automoti ve powertrai ns" , 42ND. IEEE CONFERENCE ON DECISION AND CONTROL. (CDC) . MAUI , HI , DEC. 9 - 12 , 2003 ; [IEEE CONFERENCE ON DECISION AND CONTROL] , NEW YORK, NY : IEEE, US, vol . 5, 9 December 2003 (2003-12-09) , pages 4521-4526, XP010686407 , DOI : 10. 1109/CDC. 2003 . 1272259 ISBN : 978-0-7803-7924-4 page 4521 - page 4523 ----- -/- .	1-10

Further documents are listed in the continuation of Box C. See patent family annex.

* Special categories of cited documents :

"A" document defining the general state of the art which is not considered to be of particular relevance	"T" later document published after the international filing date or priority date and not in conflict with the application but cited to understand the principle or theory underlying the invention
"E" earlier application or patent but published on or after the international filing date	"X" document of particular relevance; the claimed invention cannot be considered novel or cannot be considered to involve an inventive step when the document is taken alone
"L" document which may throw doubts on priority claim(s) or which is cited to establish the publication date of another citation or other special reason (as specified)	"Y" document of particular relevance; the claimed invention cannot be considered to involve an inventive step when the document is combined with one or more other such documents, such combination being obvious to a person skilled in the art
"O" document referring to an oral disclosure, use, exhibition or other means	"&" document member of the same patent family
"P" document published prior to the international filing date but later than the priority date claimed	

Date of the actual completion of the international search 19 January 2018	Date of mailing of the international search report 30/01/2018
---	---

Name and mailing address of the ISA/ European Patent Office, P.B. 5818 Patentlaan 2 NL - 2280 HV Rijswijk Tel. (+31-70) 340-2040, Fax: (+31-70) 340-3016	Authorized officer Dbrre, Thorsten
--	--

INTERNATIONAL SEARCH REPORT

International application No
PCT/EP2017/075476

C(Continuation). DOCUMENTS CONSIDERED TO BE RELEVANT		
Category*	Citation of document, with indication, where appropriate, of the relevant passages	Relevant to claim No.
Y	<p>MING YANG ET AL: "Study of on-line backlash identification for PMSM servo system" , IECON 2012 - 38TH ANNUAL CONFERENCE ON IEEE INDUSTRIAL ELECTRONICS SOCIETY, IEEE., 25 October 2012 (2012-10-25) , pages 2036-2042 , XP032281099 , DOI : 10.1109/IECON.2012.6388745 ISBN : 978-1-4673-2419-9 page 2036 - page 2041</p> <p style="text-align: center;">-----</p>	1-10
X,P	<p>DIMITRIOS PAPAGEORGIOU, MOGENS BLANKE, HANS HENRIK NIEMANN, JAN H. RICHTER: "Backlash estimation for industrial drive-train systems" , IFAC-PAPERSONLINE, vol . 50, no. 1, 14 July 2017 (2017-07-14) , pages 3281-3286, XP002777194, ISSN : 2405-8963 page 3281 - page 3286</p> <p style="text-align: center;">-----</p>	1-10