



## Influence of Compressor Control Strategy on Energy Efficiency and Product Temperature for Professional Counter Cabinets

Jensen, Jonas Kjær; Kærn, Martin Ryhl; Markussen, Wiebke Brix; Pedersen, Per Henrik

*Published in:*

Proceedings of the 13th IIR-Gustav Lorentzen Conference on Natural Refrigerants

*Link to article, DOI:*

[10.18462/iir.gl.2018.1248](https://doi.org/10.18462/iir.gl.2018.1248)

*Publication date:*

2018

*Document Version*

Peer reviewed version

[Link back to DTU Orbit](#)

*Citation (APA):*

Jensen, J. K., Kærn, M. R., Markussen, W. B., & Pedersen, P. H. (2018). Influence of Compressor Control Strategy on Energy Efficiency and Product Temperature for Professional Counter Cabinets. In Proceedings of the 13th IIR-Gustav Lorentzen Conference on Natural Refrigerants (Vol. 1, pp. 635-643). International Institute of Refrigeration. DOI: 10.18462/iir.gl.2018.1248

---

### General rights

Copyright and moral rights for the publications made accessible in the public portal are retained by the authors and/or other copyright owners and it is a condition of accessing publications that users recognise and abide by the legal requirements associated with these rights.

- Users may download and print one copy of any publication from the public portal for the purpose of private study or research.
- You may not further distribute the material or use it for any profit-making activity or commercial gain
- You may freely distribute the URL identifying the publication in the public portal

If you believe that this document breaches copyright please contact us providing details, and we will remove access to the work immediately and investigate your claim.

# INFLUENCE OF COMPRESSOR CONTROL STRATEGY ON ENERGY EFFICIENCY AND PRODUCT TEMPERATURE FOR PROFESSIONAL COUNTER CABINETS

**Jonas K. Jensen<sup>(a)</sup>, Martin R. Kærn<sup>(a)</sup>,  
Per Henrik Pedersen<sup>(b)</sup>, Wiebke B. Markussen<sup>(a)</sup>**

<sup>(a)</sup> Department of Mechanical Engineering, Technical University of Denmark

Kgs. Lyngby, 2800, Denmark, e-mail

<sup>(b)</sup> Danish Technological Institute,

Gregersensvej 2, DK-2630 Taastrup, e-mail

## ABSTRACT

EU regulations 2015/1095 and 2015/1094 of 5 May 2015 have been implemented for professional refrigerated counters along with the test standard EN 16825. These regulations rates most current counters as class C or D and consequently there is an ongoing development to construct top level counters (A or above). Apart from improving the cabinet construction and improving the condenser and evaporator design, advanced compressor control strategies could be part of the solution. This could be either variable speed drive (VSD) or adaptive energy optimization (AEO). Both control strategies may improve the energy efficiency but may also affect the temperature fluctuations of the stored goods. The influence of VSD and AEO was investigated using a validated dynamic model of a professional refrigerated counter using R290 and R600a. The influence was investigated according to the EN 16825 test conditions. Both VSD and AEO yield significant energy savings compared to ON-OFF control. A more constant product temperature was achieved by VSD control, while the product temperature fluctuates slightly more when applying AEO control.

Keywords: Hydrocarbon, Compressor control, Variable Speed Drive, Product temperature, Eco-design

## 1. INTRODUCTION

In may 2015 the European Union passed regulation 2015/1094 (Council of European Union, 2015a) and 2015/1095 (Council of European Union, 2015b) and thereby implemented eco-design and energy-labelling requirements to professional refrigerated storage cabinets, such as professional counter cabinets. These regulations have been enforced since July 1<sup>st</sup> 2016 and require all professional refrigerated storage cabinets to be tested and classified in accordance with EN 16825 (CEN, 2016). Based on the test procedure described in EN 16825 the daily power consumption of the storage cabinet is measured from which the cabinet can be classified on a scale ranging from D to A<sup>+++</sup>. Storage cabinets with a power consumption in excess of what corresponds to class D can no longer be sold within the European Union.

As this type of refrigeration equipment has not previously been subjected to eco-design and energy-labelling requirements, the development of this type of equipment has to some extent been focused on other measures, such as durability and cost reduction rather than a reduction of the power consumption. Hence, most current storage cabinets are assumed to be in the lower end of the scale. This is exemplified in Pedersen et al. (2018), where it was found that a current professional counter cabinet was classified in class C.

Consequently, there is an ongoing development task in designing professional storage cabinets capable of being classified in the top range of the scale (A - A<sup>+++</sup>). For the professional counter cabinet investigated by Pedersen et al. (2018) reaching class A requires a reduction of the daily power consumption of more than 50 %.

The objective of the present study was to investigate the influence of a range of improvement measures on

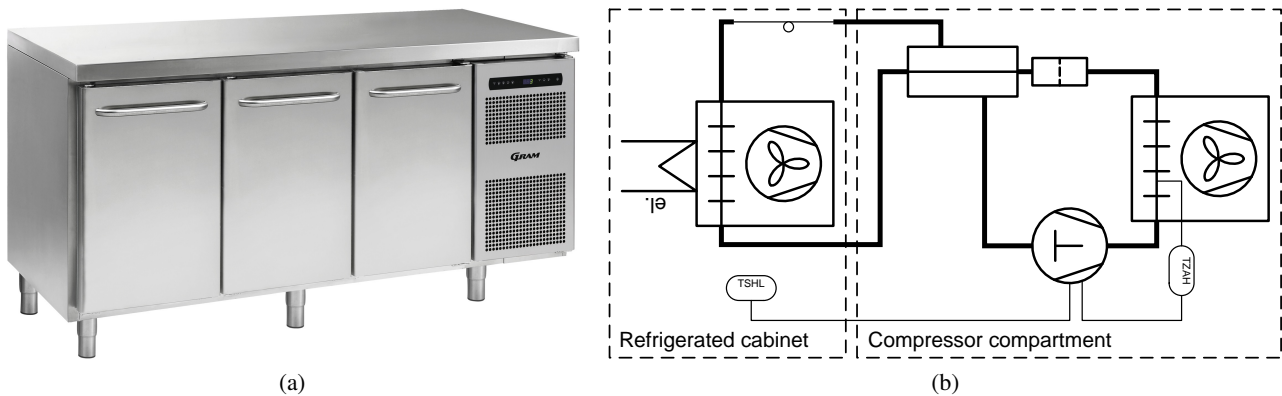

Figure 1. (a) Professional counter cabinet installed with three doors, the cabinet may also be equipped with upto six drawers (Gram Commercial, 2018). (b) PI - diagram of the installed refrigeration systems of the professional counter cabinet.

Table 1. Auxiliary power consumers

Condenser fan	$\dot{W}_{CO, fan}$	28.3 W	on if: $T_{cond} > 30\text{ }^{\circ}\text{C}$
Evaporator fan	$\dot{W}_{EV, fan}$	13.0 W	on unless: defrost on
Defrost	$\dot{W}_{DF}$	281 W	On for 5 min every 6 h
Control panel	$\dot{W}_{control}$	4.90 W	Always on

the power consumption and product temperatures of the professional counter cabinet described in (Pedersen et al., 2018). The investigated measures include both improvement of the cabinet envelope by increasing insulation thickness and reducing thermal bridges as well as improvements to the condenser, evaporator and compressor. For the compressor a range of fixed speed and variable speed drive (VSD) compressors, for both R290 and R600a, have been identified and investigated. The alternative compressors were investigated under three compressor control strategies: ON-OFF, Adaptive Energy Optimization (AEO) and VSD.

## 2. METHODS

### 2.1. Current counter cabinet

The current counter cabinet may be seen in Fig. 1a. The counter cabinet investigated in the present study was installed with three doors, however the cabinet may also be installed with up to six drawers or with any combination of these. The cabinet had a net volume of 290 L and was insulated by a layer of Polyurethane (PU) foam with a thickness of 50 mm in the side and bottom walls and 38 mm in the top desk. The top desk additionally included a wooden-fibreboard with a thickness of 12 mm. Further, the inner and outer walls were lined with a thin sheet of stainless steel.

The cabinet was cooled by a R290 refrigeration system the layout of which may be seen in Fig. 1b. The refrigeration system was comprised of a fin-tube condenser with a condenser fan, and fin-tube evaporator with an evaporator fan, a capillary tube - suction line heat exchanger and a compressor. The applied compressor in the current counter cabinet was a SECOP TL5CN. The currently applied compressor control strategy was ON-OFF based on a high/low temperature switch placed in the evaporator outlet air stream. Further, the evaporator was equipped with an electric heating element used to defrost the evaporator with six hour intervals.

Apart from the compressor, the counter cabinet consumes power for several auxiliary equipment. The auxiliary equipment power consumption was used for condenser and evaporator fans, defrost heating element and the control panel. The power consumption and control of the auxiliary equipment was stated in Table 1.

### 2.2. Suggested improvements

In order to reduce the power consumption of the counter cabinet a number of measures have been investigated. These consist of:

- Change of compressor type and compressor control strategy

- Improvements of the cabinet envelope i.e. increasing insulation thickness and reducing thermal bridges. According to Pedersen et al. (2018), 2 cm of additional PU-foam is possible and further the heat load due to thermal bridges can be reduced by 95 %.
- Increase heat transfer performance of the evaporator and condenser i.e increase the UA-value. For the simulations a doubling of the UA-value was investigated. This can be attained either by improving the heat transfer coefficient,  $U$  or increasing the area  $A$ , or a combination of the two improvements. It should be noted that a doubling of the UA-value may not be achievable in practice due to spacial and economic constraints and thus the simulations with double UA-value mainly serves as an investigation of the potential of increasing energy efficiency by improvement of the heat exchanger performance.
- Replace fans with more energy efficient fans and improve condenser fan control. In the current cabinet the condenser fan was on when the condenser temperature was above 30 °C, which means that under the EN 16825 test conditions the condenser fan was always on. This could be improved by letting the fan turn ON-OFF with the compressor. It was further assumed that the fan power could be reduced to 10 W for the condenser and to 6.2 W for the evaporator

A number of relevant compressor types have been identified and are listed in Table 2. As seen, the identified compressors consist of a number of ON-OFF controlled R290 compressors, one VSD R290 compressor and a VSD R600a compressor. The ON-OFF compressors were all assumed to be controlled by a high/low temperature switch measuring the air temperature in the refrigerated space. The VSD compressors all accommodate two modes of control: VSD control in which the compressor speed was controlled to attain a given set-point temperature of the air in the refrigerated space and AEO control in which the compressor runs ON-OFF based on high/low temperature switch while the compressor speed was controlled to attain a given set-point for the compressor on-time. The AEO control algorithm is a built in function in both SECOP VSD compressors and will be activated if the compressor only receives an input signal from a normal cut-in cut-out thermostat switch (SECOP, 2018). Hence, the AEO control strategy can be applied as a direct replacement of a fixed speed ON-OFF compressor with no additional controls required. Conversely, to run the VSD control strategy the compressor controller needs a control frequency signal supplied by an external appliance controller (typically PI) (SECOP, 2018). Consequently, the manufacturer must purchase and tune this additional PI-controller in order to apply VSD control, thus increasing the engineering and capital cost of the product. Hence, significant performance improvements should be attained by the VSD control in order for VSD to be viable compared to the built-in AEO control.

For VSD control, the compressor would return to ON-OFF operation based on the high/low temperature switch in case the set-point temperature cannot be met at the minimum compressor speed.

In the present study the set point for the high/low temperature switch was set to 6 °C and -2 °C, respectively. For the AEO control three set-points for the compressor on-time,  $\Delta\tau_{on}$ , were investigated: 1, 2 and 4 hours. For the VSD control the set-point for the air temperature was set to 2 °C.

In order to determine the most beneficial improvements, the potential improvements of the counter cabinet were investigated individually and in combination. The improvements were evaluated based on both the power consumption as well as on the minimum, maximum and average product temperature.

Table 2. Compressor data for the investigated compressor types

Compressor model	Refrigerant	Displacement Volume	Control	Nominal speed	Speed range
TL5CN	R290	5.08 cm <sup>3</sup>	ON-OFF	2900 RPM	-
DLE48CN	R290	4.80 cm <sup>3</sup>	ON-OFF	2900 RPM	-
DLE48CNRC	R290	4.80 cm <sup>3</sup>	ON-OFF	2900 RPM	-
DLE4CN	R290	4.00 cm <sup>3</sup>	ON-OFF	2900 RPM	-
DLE4CNRC	R290	4.00 cm <sup>3</sup>	ON-OFF	2900 RPM	-
DLV57CN	R290	5.70 cm <sup>3</sup>	VSD/AEO	2900 RPM	1000–4000 RPM
XV5KX	R600a	5.00 cm <sup>3</sup>	VSD/AEO	2900 RPM	1000–4000 RPM

### 2.3. Model

A thermodynamic model of the refrigerated counter has been build in the simulation software Engineering Equation Solver (Klein, 2017). The model structure can be seen in Fig. 2. The model was comprised of a cabinet model and a refrigeration system model. The two models interact through the heat load in the evaporator.

The cabinet was modelled as an air control volume enclosed by an insulated wall control volume, i.e the cabinet. Inside the air volume a product control volume was placed, such that the stored product only exchanged heat directly with the air volume. The wall, air and product control volumes where all modelled as dynamic control volumes and the transient temperatures were determined. The air and product volumes were modelled as lumped capacitances while transient conduction through the walls was calculated based on a discretization along the width of the wall.

Apart from the heat load through the walls the air experienced a heat load due to the evaporator fan,  $\dot{W}_{EV,fan}$ , due to thermal bridges,  $\dot{Q}_{TB}$ , and due to air infiltration. The heat load due to thermal bridges was determined based on a quasi static approach by assigning a fixed UA-value and thus finding  $\dot{Q}_{TB} = UA_{TB} (T_{amb} - T_{air})$ . Two sources of air infiltration was accounted for. One due to pressure equalization with the ambient and one due to door openings. The mass flow of infiltrated air due to door openings was determined based a fixed number of air exchanges.

The refrigeration system model was comprised of two dynamic components: the evaporator and the condenser, and two quasi static components: the compressor and the capillary tube - suction line heat exchanger. Both the condenser and evaporator were modelled as a refrigerant control volume enclosed in a heat exchanger volume with a given capacitance. The operation of the compressor was determined based on polynomials supplied by the manufacturer, for the VSD compressors speed specific polynomials were applied. Compressor heat loss was neglected.

To simulate the operation of the refrigerated counter under the EN 16825 test procedure several model parameters where fitted to match the experimental data supplied. These parameters where: the convective heat transfer coefficient on the walls and product (assumed to be the same), convective heat transfer coefficient on the evaporator and condenser (separate values), the UA-value for the thermal bridges and the number of air exchanges due to door openings.

### 2.4. Measurements according to EN 16825

The current counter cabinet has been tested in accordance with EN 16825 . The results of these test are presented in detail by Pedersen et al. (2018). The test was conducted with test packages stored in the cabinet. The test packages were of made of Tylose gel and the amount and placement where dictated by the EN 16825 test procedure.

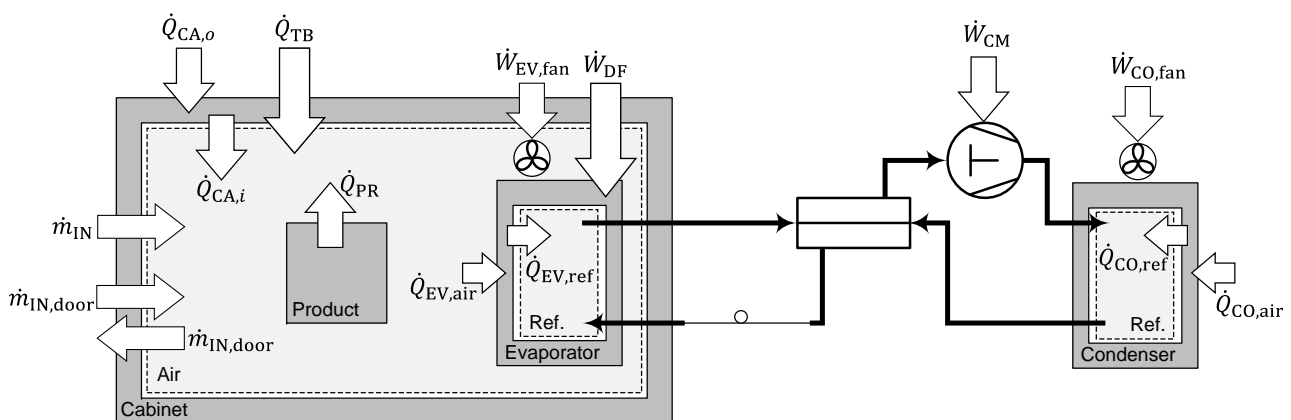

Figure 2. Principal sketch of the model structure of the cabinet and refrigeration system. The grey areas all model as dynamic control volumes.

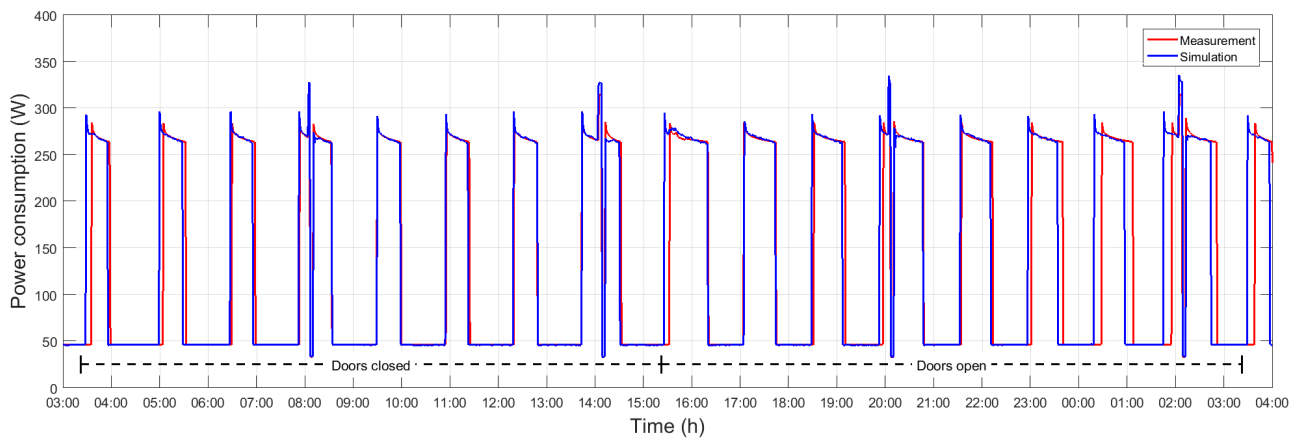

Figure 3. Simulated and measured energy consumption during a 24 hours sequence of the EN 16825 test

Table 3. Values of the fitted model parameters

Model parameter	Fitted Value
$UA_{TB}$	$2.45 \text{ WK}^{-1}$
$UA_{EV}$	$67.7 \text{ WK}^{-1}$
$UA_{CO}$	$49.1 \text{ WK}^{-1}$
$\alpha_{air}$	$6.52 \text{ Wm}^{-2}\text{K}^{-1}$
$N_{air,inf}$	$4.6 \text{ h}^{-1}$

The EN 16825 test procedure is comprised of three days run time. The first 24 hours are to allow the system to reach stable operation. For the second 24 hours the temperatures are measured in the test packages. For the last 24 hours, both the power consumption and test package temperatures are measured. Each 24 hour interval are divided into two periods: the first 12 hours all doors are closed, the second 12 hours all three doors are open and closed in a scheme dictated by EN 16825. The door opening scheme in EN 16825 consists of an initial door opening where all doors are open for a duration proportional to the net volume, following all doors are opened at a given interval and are kept open for a designated duration. The door opening scheme seeks to simulate a typical user pattern in a commercial application.

The results of the measurements have been used to fit several unknown coefficients in the thermodynamic model, as described in section 2.3. Further, the results of the measurements have been used to validate the developed thermodynamic model under the EN 16825 test procedure.

## 2.5. Validation

The total power consumption of the measured and simulated system can be seen in Fig. 3. As seen, the model captures both the overall power consumption but also the duration and number of the ON-OFF cycles during both the closed door part of the test and the door opening part of the test. As seen, when the doors were opened, the compressor on-time was slightly increased while the compressor off-time was slightly decreases. Thus, the power consumption was higher when the doors were opened. This was caused by the additional infiltration of warm and humid ambient air when the doors were open. As stated in Table 3 the additional air infiltration during the door opening scheme corresponded to an air exchange of 4.6 per hour. This was equivalent to an average heat load of approximately 44 W during the door opening part of the test

The additional fitted values of the model parameters can also be seen in Table 3.

The simulated daily power consumption was found to be 3.31 kWh per days which differs 1.34 % from the measured value. The developed thermodynamic model thus presents a reasonable representation of the system and can thus be used to further investigate the improvement potentials.

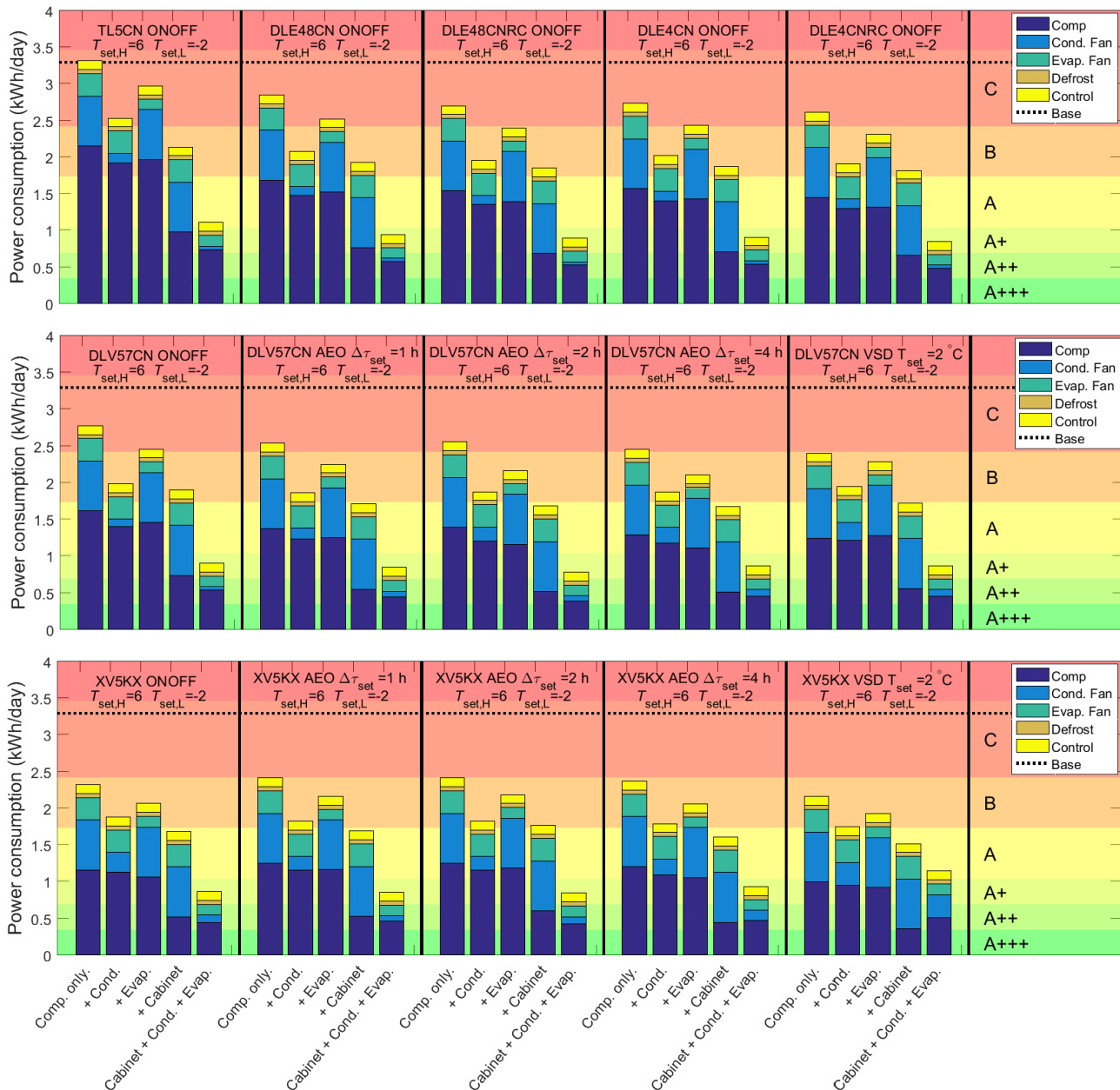

Figure 4. Power consumption for different design improvements and compressor types

### 3. RESULTS

#### 3.1. Power consumption and product temperature

The power consumption of the simulated improvements can be seen in Fig. 4. Here the results are presented for both the ON-OFF, AEO and VSD control. The results are presented for changing the compressor only and for adding each of the additional improvements, presented in section 2.2, individually and all together. Further, the corresponding minimum, maximum and average product temperatures are seen in Fig. 5.

Starting from the base case, the TL5CN compressor, it can be seen that the two largest potentials for power consumption reduction stem from the condenser and cabinet improvement. It can further be seen that the improvements due to the condenser was mainly related to the reduction of fan power rather than the improved UA-value. It can be seen that the target of a class A counter can be met if all improvements are implemented in the system with the current compressor.

Going further it can be seen that additional reduction can be attained by also implementing new compressors.

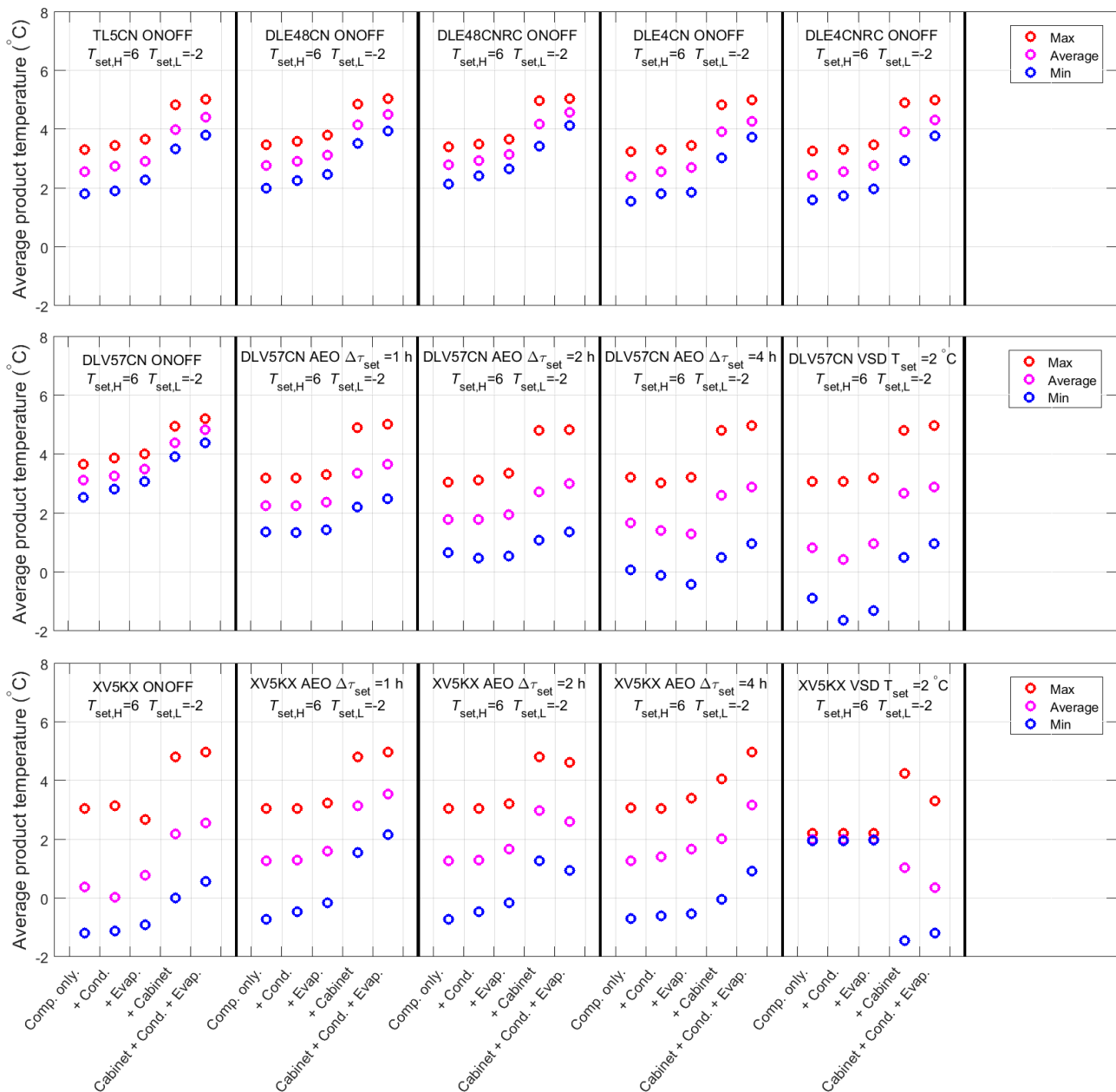

Figure 5. Minimum, maximum and average product temperature for different design improvements and compressor types

The DLE48CN/RC and DLE4CN/RC are both R290 compressors like TL5CN but with smaller displacement volumes and improved performance. It can be seen that the smallest compressor in the RC version has the biggest potential to reduce the power consumption. Further, it can be seen that the smaller the compressor size was: the less improvement was attained by increasing the UA-value of the evaporator and condenser. This was due to the fact that by reducing the compressor size the heat load in the evaporator and condenser was reduced, which in it self increased the evaporation and reduced the condensation temperature, leaving less potential to do so by the increasing the UA-value. An A<sup>+</sup> rated counter can be attained if all improvements are implemented together with either the DLE48CN/RC or DLE4CN/RC.

Looking at Fig. 5 it can be seen that all suggested improvements have a significant influence on the temperature of the stored goods. For the ON-OFF compressors it can generally be seen that improving the evaporator, condenser or cabinet will result in an increase in the average product temperature. The highest influence on this was related to the improved cabinet. This was due to the fact that improving the cabinet without changing the compressor results in reduced cooling demand and thus in excess cooling capacity. Consequently, the compressor on-time will be reduced and the off-time will be increased. This means that the product on average



will be exposed to hotter air resulting in an increase in product temperature. It can further be seen in Fig. 5 that reducing the compressor size to the DLE4CN/RC slightly reduces the product temperature again. However, an increase in product temperature should be expected when implementing the cabinet improvements. This could be counter-acted by changing the set-point temperatures of the temperature switches.

Apart for the ON-OFF controlled R290 compressor a VSD R290, DLV57CN, compressor has also been investigated and the results are presented in Fig. 4. As seen the DLV57CN has been simulated first with ON-OFF control, then with the AEO control with three different on-time set-points and finally as VSD controlled. As seen, the DLV57CN in ON-OFF results in a power consumption comparable to the DLE48CNRC. However, it may be seen that additional reduction can be attained by running the AEO control. It can be seen that, the longer the on-time set-point was: the lower the power consumption. This is the same effect as seen for downsizing the ON-OFF compressors, as increasing the AEO on-time set-point forces the compressor to run at reduced speed thus mimicking a smaller compressor. This was also apparent when examining Fig. 5 where it can be seen that the higher the AEO on-time set-point was, the lower the product temperatures were and the higher the product temperature spans were. This may be critical for the product quality if sub-zero temperatures are attained. As seen, this occurred for the 4 hour AEO set-point and the VSD control. Looking at the temperature results for the VSD control of the DLV57CN it was evident that actual VSD control has not been attained as this should result in minimum, maximum and average temperature very close to the VSD temperature set-point. The reason for this was that the DLV57CN compressor was too large to run full VSD under the load conditions in the refrigerated counter. The results seen here, therefore represent the DLV57CN compressor running ON-OFF at its minimum speed of 1000 RPM.

The final compressor investigated was the XV5KX compressor. The XV5KX is a VSD R600a compressor, the results for this compressor was structured similarly to those of the DLV57CN. As seen the power consumption for ON-OFF drive was reduced compared to all other ON-OFF compressor. However, when looking at the product temperatures it may also be seen that freezing of the product occurred when the cabinet was not improved. This indicates that the cooling capacity was too low for ON-OFF control, resulting in too long on-time and thus a longer exposure time to sub-zero. This was further justified by looking at the power consumption for the AEO and identifying that these are higher than for ON-OFF control. Hence, the average on-time of the ON-OFF control was greater than 4 hours. Finally, it may be seen that the power consumption can be further reduced by applying VSD control. Looking at the product temperatures it can be seen that actual VSD control was attained if the cabinet was not improved. As seen this results in minimum, maximum and average temperatures close to the 2 °C temperature set-point. However, when the cabinet was improved the XV5KX was also too large for VSD control and thus to run the completely improved system with VSD a smaller compressor would be needed.

#### 4. CONCLUSIONS

A number of potential improvements to the design of a refrigerated counter cabinet have been investigated using a validated thermodynamic model. The model was found to give a good representation of both the overall power consumption and the on and off time of the compressor. Seven compressor types were simulated under both ON-OFF, AEO and VSD control. Further, improvements to the cabinet, evaporator and condenser were simulated. The biggest improvement was attained by improving the cabinet followed by improving the condenser. For the condenser the biggest improvement was attained by reducing the fan power. Improving both condenser, evaporator and cabinet resulted in an increase in the product temperature. Reducing the compressor size would reduce the average power consumption and reduce the average product temperature, which to some extent can counter act the increase from the other improvements. It is therefore important to determine a good trade off. The AEO control method generally mimics the operation of a smaller compressor and thus increasing the on-time set-point reduces power consumption and reduces product temperature. VSD control was only possible for a small number of investigated solutions. The DLV57CN was too large to run VSD for all investigated cases, while XV5KX could run VSD if the cabinet was not improved. All in all several possibilities were identified to construct a counter cabinets capable of being award class A or above.

## ACKNOWLEDGEMENTS

This research project is financially funded by EUDP (Energy Technology Development and Demonstration). Project title: "Refrigerated counters of the future", project number: 64015-0064

## NOMENCLATURE

<i>Abbreviations</i>	$\dot{m}$ mass flow rate ( $\text{kg s}^{-1}$ )
EES Engineering Equation Solver	<i>Greek letters</i>
AEO Adaptive Energy Optimization	$\alpha$ convective heat transfer coefficient ( $\text{W m}^{-2} \text{K}^{-1}$ )
VSD Variable Speed Drive	$\Delta\tau$ time difference (s)
PU Polyurethane	<i>Sub- &amp; super scripts</i>
<i>Symbols</i>	CM compressor
$p$ pressure (bar)	CO condenser
$T$ temperature (K)	EV evaporator
$V$ volume ( $\text{m}^3$ )	DF defrost
$\dot{Q}$ heat flow rate (W)	IN infiltration
$\dot{W}$ work rate (W)	TB thermal Bridges
UA Over all heat transfer coefficient ( $\text{W K}^{-1}$ )	PR product

## REFERENCES

- CEN, 2016. EN 16825 - Refrigerated storage cabinets and counters for professional use. Classification, requirements and test conditions .
- Council of European Union, 2015a. Commission delegated regulation (eu) 2015/1094 of 5 may 2015 supplementing directive 2010/30/eu of the european parliament and of the council with regard to the energy labelling of professional refrigerated storage cabinets (text with eea relevance). URL: [http://eur-lex.europa.eu/eli/reg\\_del/2015/1094/oj](http://eur-lex.europa.eu/eli/reg_del/2015/1094/oj).
- Council of European Union, 2015b. Commission regulation (eu) 2015/1095 of 5 may 2015 implementing directive 2009/125/ec of the european parliament and of the council with regard to ecodesign requirements for professional refrigerated storage cabinets, blast cabinets, condensing units and process chillers (text with eea relevance). URL: <http://data.europa.eu/eli/reg/2015/1095/oj>.
- Gram Commercial, 2018. URL: <http://gram-commercial.com/dk/da-dk/gastro-k-1807-csg-a-dldldr-12>.
- Klein, S., 2017. Engineering equation solver academic professional v10.273-3d.
- Pedersen, P.H., Jensen, J.K., Reinholdt, N.P., Markussen, W.B., Hansen, M.L., 2018. Energy efficient professional counter cabinet. Proceedings of the 13th Gustav Lorentzen Conference, Valencia, Spain .
- SECOP, 2018. Xv controllers attached electronic unit. URL: [https://www.secop.com/fileadmin/user\\_upload/technical-literature/operating-instructions/xv\\_attached\\_controller\\_101n05022\\_operating\\_instructions\\_11-2014\\_dess300h102.pdf](https://www.secop.com/fileadmin/user_upload/technical-literature/operating-instructions/xv_attached_controller_101n05022_operating_instructions_11-2014_dess300h102.pdf).