

Design of a Wireless Passive Sensing System for Impact Detection of Aerospace Composite Structures

Hailing Fu, *Member, IEEE*, Aldyandra Hami Seno, Zahra Sharif Khodaei and M. H. Ferri Aliabadi
Department of Aeronautics, Imperial College London
London, SW7 2AZ, United Kingdom

E-mail: h.fu14, a.hami-seno16, z.sharif-khodaei and m.h.aliabadi@imperial.ac.uk

Abstract—In this paper, the design and implementation of a novel on-board wireless passive sensing system for impact detection of composite airframe is presented for the first time. Several modules, including filtering, impact detection, local processing and wireless transmission are designed and evaluated for detecting rare, random and transitory impact events. An event-triggered mechanism with high responsiveness is adopted to reduce the system power dissipation and to maintain the detection effectiveness. This design allows the system to be adaptive, energy-efficient and highly responsive to impacts. The whole system was implemented in an experimental study, and the effectiveness was evaluated and illustrated. The system was woken up by impact events in around 12 μ s, and the impact data were recorded at 200 kHz (up to 5.33 MHz). This work provides a guideline for low-power, high-responsiveness passive on-board sensing system design. This system can also be adapted to other sensing applications in aerospace engineering.

Keywords—structural health monitoring, composite structures, passive sensing, wireless sensing networks, impact detection.

I. INTRODUCTION

In aerospace engineering, reducing the system weight while maintaining the operation safety is one of the challenges in aircraft or space vehicle design. Composite materials, due to the improved mechanical properties, high corrosion resistance and reduced weight, become an ideal option for designers [1]. These materials, consequently, are increasingly being used in aircraft primary structures including B787, Airbus A380, F35, and Typhoon. However, composites are vulnerable to impacts, even those at low velocities. Potential damage, such as delamination, indentation, and fibre cracking, can be induced [2, 3] as a result of barely visible impact damage (BVID). Regular checks and maintenance, which are time consuming and costly, are compulsive to evaluate the structure's integrity. Unfortunately and unavoidably, damage can also be caused by the regular checking and maintenance process from human interference, such as tool dropping.

Structural health monitoring (SHM), as a promising methodology for continuous monitoring of critical structures, such as civil infrastructure [4], high-speed railway systems [5] or aircraft [6], has been widely used to increase the awareness of structure's operation conditions and to reduce to system maintenance cost as well as the human-induced interference. For the monitoring system, it is generally comprised of multiple wireless (cable-free) sensing nodes distributed in a specific configuration on the monitored object. These sensing nodes, as a group, establish a wireless sensing network (WSN)

[7]. By collecting and processing the structural dynamics from different sensing locations, the conditions can be evaluated and determined. For each sensing node, different units, including sensing, processing, wireless transmitting modules and power source are generally designed.

For impact detection of composite airframe, various sensing (detecting) methods, such as optical methods, eddy-current, acoustic emission, radiography, thermography and Lamb waves, have been developed [8]. Piezoelectric-based Lamb wave detection is one of the main diagnostic methods used in composite SHM, due to its simplicity in structure and reliability in detecting [9, 10]. This method is possible to be implemented on board unobtrusively with low device dimensions and weight. Sharif-Khodaei *et al.* studied a piezoelectric-based active sensing method for locating impacts on composite stiffened panels [11-13]. Piezoelectric transducers are used both as sensors and as actuators. In one operation cycle, one transducer is used as the actuator, and the rest are used as sensors to detect the actuation-induced Lamb waves. Based on the sensing signals for different pathways, the damage can be detected and localized. This method has the advantage of the certainty and manoeuvrability in the excitation signal, but the system requires additional circuits for signal generation, amplification and excitation sequence control. These additional requirements make the system complicated and increase the system power consumption.

Compared to active sensing, passive sensing is another SHM methodology which requires only sensing modules [14-16]. External impacts, such as hail or bird strikes, are used as the actuating source. This requires the system to be always-on in order to be able to detect any random and transitory impact events. However, the always-on operation requires tremendous energy from the power supply module, which is a hindrance of long-term operation. Event-triggered mechanisms have been adopted in many applications, such as monitoring the activity of an active volcano [17] or detecting anomalous events in a smart-city scenario for effective operator coordination as well as passenger communication [18]. This event-triggered method allows the system to stay in low-power mode when there is no concerned events, and to exhibit high performance when the system is triggered. The average power consumption can be reduced when events are rare. The reduced power consumption is critical for SHM using wireless sensors to extend the system operation duration before the power source, such as batteries, needed to be replaced or recharged. The whole system can also potentially become a self-powered battery-less system using

The research leading to these results has gratefully received partial funding from the European JTI-CleanSky2 program under the Grant Agreement n° 314768 (SHERLOC).

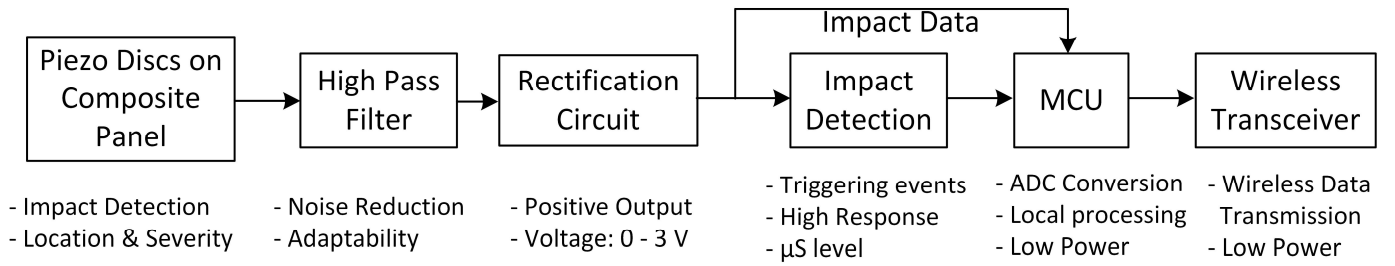

Fig. 1. System function diagram for the wireless passive sensing system for impact detection. The system is divided into 6 blocks according to its functions. The key requirements and functions for each module are discussed and summarized below each block.

energy harvesting technology to convert ambient kinetic energy into electricity [19].

This event-triggered mechanism is ideal for cases where events are rare and random, but for impacts on composite airframe, they are not only rare and random, these events also happen in a short time frame (e.g. 3 ms) [20]. In order to localize and evaluate these impact events, the initial waveforms recorded by each sensor are the most important data, as these data (arrival time and peak amplitude) indicate the impact location and energy. Therefore, when an event-triggered mechanism is adopted, high system responsiveness is crucial to effectively and accurately detect impacts with input energies above a certain threshold which could cause damage in the structure.

In this paper, the design and implementation of a wireless passive sensing system for detecting impact events in aerospace composite structures is presented. An event-triggered method with high responsiveness is developed to reduce the system power consumption while maintaining the system detecting effectiveness. The system provides a novel solution for on-board structural health monitoring with the advantages of low power consumption, high compactness, light weight and high data acquisition performance. To the authors' knowledge, this system design for composite impact detection has never been reported in the literature. This work can also be adapted to other low-power sensing system design in many aerospace engineering applications.

II. SYSTEM DESIGN AND OPERATION PRINCIPLE

A. System Configuration

Fig. 1 illustrates the configuration of the proposed sensing system. Six modules are designed, including piezoelectric sensors, high pass filters, rectification circuits, impact detection module, local processing module (micro-controller unit, MCU), and wireless transmission module. Piezoelectric (PZT) sensors are mounted on composite structures in specific configurations. Voltages are generated on the PZT sensors due to the stress waves caused by impacts or environmental vibration.

Back-ground vibrations and noise should be filtered out for effective impact detection, as these vibrations can also trigger the system and lead to false alarms. Impact-induced ultrasonic waves typically have abundant frequency components over a wide bandwidth. Some high-frequency components can still

remain when the ambient vibrations are filtered out by the high-pass filter module, and these components can be used for impact localization and evaluation. The proposed filter module, therefore, increases the system adaptability for different environmental conditions during aircraft operation.

The voltages recorded by PZT sensors are in an alternative form which is not suitable for MCUs. Therefore, a rectification circuit is necessary for each PZTs. All the rectified signals are compared to a reference voltage (threshold voltage, V_{th}) in the impact detection module. If one of the signals is larger than V_{th} , a trigger signal is generated from this detection module.

The local processing module is designed to operate in a low-power mode when there are no impacts. When a trigger signal is detected by the wake-up pin on the MCU, the system starts up immediately, and data from all the PZTs are recorded. The wake-up delay for the MCU should be as short as possible to record the initial data of impacts. Necessary parameters, such as the Time of Arrival (ToA) or Amplitude of the First Peak (AoFP), are extracted from the recorded data by the MCU. Then, the MCU wakes the wireless transceiver up from a low-power mode, and transmit the extracted data to the host station via this wireless module for impact evaluation.

According to the above description and discussion, the key design considerations for this system are:

- Low-power operation when no impact occurs;
- Event-triggered method for impact detection with high system responsiveness;
- High system data acquisition rate when triggered.

The system design is conducted based on the above listed design considerations. The main focus in the following sections is on the impact detection and local processing modules.

B. Impact Detection Module

In order to wake up the local processing module from a low power mode when impacts occur, an impact detection circuit is necessary. This circuit should be low-power, as it is required to be always-on to detect any potential impacts. Meanwhile, the response delay for this module should be well limited to allow the system to capture the event profile to the largest extend.

Fig. 2 shows the design for impact detection and trigger signal generation. A comparator is connected to each PZT (Ch i , $i = 1, 2, \dots, n$). The output from each PZT is compared to a threshold voltage Ref . When there is no impacts, the output Ch

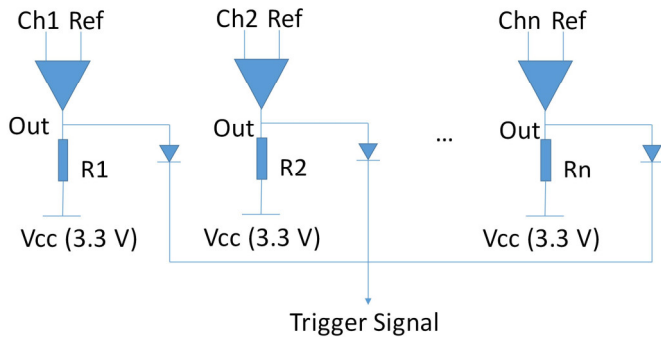

Fig. 2. Impact detection circuit design, showing the trigger signal generation method. The comparator has two states: grounded when $Ch_n < Ref$ and open circuit when $Ch_n > Ref$. The rising edge is used to wake up the MCU.

i is lower than Ref . The output, based on the characteristics of comparators, is grounded. When impacts occur, one of these channels will first exceed the threshold Ref , and the output is open-circuit. Each comparator's output is connected via a pull-up resistor to the power supply V_{cc} . The trigger signal which is used to wake up subsequent processing units is obtained from the output of each comparator via a diode. The trigger signal is grounded when there are no impacts, and reaches V_{cc} , when the impact-induced voltage on any comparison channel is higher than the threshold ($Ch_i > Ref$). This rising edge in the trigger signal is used for waking-up the MCU.

C. Local Processing Module

Several functions are assigned for the local processing module. First, the module should be able to accurately record all the impact signals from all the input channels with an appropriate sampling frequency. A larger number of allowable input channels is desirable, as this means this module can be connected to more sensors to cover a larger monitoring area. Secondly, the required parameters, such as ToA or AoFP, need to be extracted from the original data by the local processing module to reduce the amount of data which needs to be transferred back to the main diagnostic unit. Finally, the processing module should control the transceiver module to send the extracted parameters to the final destination (main diagnostic unit). In addition, as the processing module is power consuming when it is active, this module should stay in a low-power mode when no impacts occur.

Based on the above discussion, the MCU "STM32L476ZE" from STMicroelectronics is chosen here for local processing. It is based on the high-performance ARM[®] Cortex[®]-M4 32-bit core operating at a frequency of up to 80 MHz. This MCU has up to 24 ADC channels for input PZTs with the conversion speed up to 5.33 Ms/s. It has seven different low-power operation modes, including sleep, stop, standby and shut-down mode. The power consumption and wake-up time for different operation modes are summarized in Table I. Based on the trade-off between the wake-up time and the power consumption, Stop 1 and Stop 2 are chosen for the low-power operation mode for this MCU.

TABLE I. POWER CONSUMPTION AND WAKE-UP TIME FOR DIFFERENT LOW-POWER MODES

| Low-Power Mode | Current Consumption | Wake-Up Time |
|----------------|--------------------------|----------------------|
| Sleep | 13 – 37 μ A/MHz | 6 cycles |
| Stop 0 | 108 μ A | 4.5 μ s in Flash |
| Stop 1 | 6.6 μ A without RTC | 6 μ s in Flash |
| Stop 2 | 1.1 μ A without RTC | 7 μ s in Flash |
| Standby | 0.12 μ A without RTC | 14 μ s |
| Shut-down | 0.03 μ A without RTC | 256 μ s |

III. SYSTEM IMPLEMENTATION AND EVALUATION

A. System Implementation

According to the design considerations, the whole system is designed and implemented on a breadboard, as shown in Fig. 3. Evaluation circuits are employed in this set-up for prototyping. The whole device dimensions can be further miniaturized on a printed circuit board with customized design. Four blocks, including rectification circuit, impact detection circuit, MCU, and ZigBee module, are divided based on their functions. There were 4 input channels implemented (can be extended up to 24 channels). Each channel is connected to a bridge rectifier and a voltage comparator. All the channels after rectification are connected to the MCU ADC inputs for recording. The trigger signal from the impact monitoring circuit is connected to an external interrupt pin on the MCU for waking-up. A ZigBee module is adopted to wirelessly transmit the extracted data to the final destination when required.

B. Experimental Evaluation

The system was first tested using one input channel. The rectified result was recorded by an oscilloscope and also the MCU for comparison. The trigger signal was also measured. The result is shown in Fig. 4. The threshold voltage was set as 0.13 V. At 0 s, an impact was introduced. The trigger signal (Fig. 4(b)) reaches 3 V immediately when the impact-induced

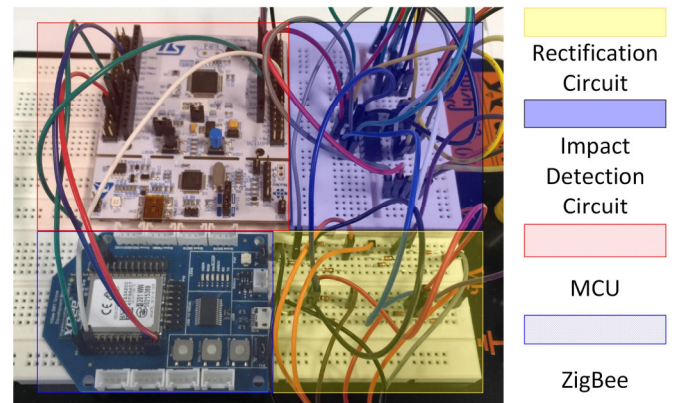

Fig. 3. System implementation of the system for impact detection on a breadboard. Four function blocks are divided based on their functions. The system can be further miniaturized with a customized printed circuit board.

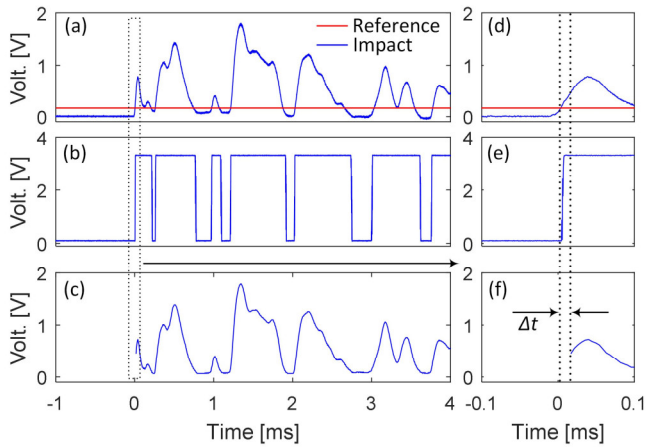

Fig. 4. Impact responsiveness. (a) Rectified voltage of the impact on one PZT recorded by an oscilloscope at 2 MHz; (b) the trigger signal generated from the impact signal; (c) Rectified impact signal recorded by the MCU at 200 kHz. (d), (e) and (f) are the enlarged view of the frame in (a), (b) and (c), respectively.

voltage is larger than the threshold. After a short wake-up delay, the MCU starts the recording process, as shown in Fig. 4(c). By comparing the results from Fig. 4(a) and (c), the MCU is capable of accurately recording the impact data at 200 kHz. However, the initial data of the impact are lost due to the system delay as a result of the event-triggering mechanism. The detailed process of the trigger signal and time delay of the MCU is shown in Fig. 4(d), (e) and (f). The time delay, as shown in Fig. 4(f), is around 12 μ s.

Although the initial part of the signal is lost, as shown in Fig. 4(c), the MCU is still capable of capturing the first peak. Compared to the signal recorded by the oscilloscope in Fig. 4(a), the data recorded by the MCU have similar performance, but with much smaller device dimensions, weight and also lower power consumption. The reduced power consumption allows the system to be potentially powered by energy harvesters using ambient energy sources, such as airflow [21] or rotation [22] or vibration [23] to make the system self-powered and autonomous.

The system was then tested with multiple input channels (4 PZTs). Four sensors were amounted along the edges of a flat composite panel ($290 \times 200 \times 4$ mm). An impact was produced on the location close to Sensor1 (Ch 1) and Sensor 3 (Ch3). The data recorded by the MCU are shown in Fig. 5. Due to the wake-up delay, the initial impact data for Ch 1 & Ch 3 are not recorded, but for the rest of the channels, the recorded impact data are complete.

In Fig. 5, the original impact signals for four channels are presented. The amplitude of the first peak (AoFP, $P_1 - P_4$) for each channel can be extracted from the original signals. The time of arrival (ToA, $t_1 - t_4$) information can be calculated by locating the first time that the output exceeds the set threshold (e.g. the arrival time of the first peak). Based on the extracted parameters, the impact can be located and evaluated.

The sensing strategies for these passive low-power sensing system can be set as: use a channel which is close to the impact

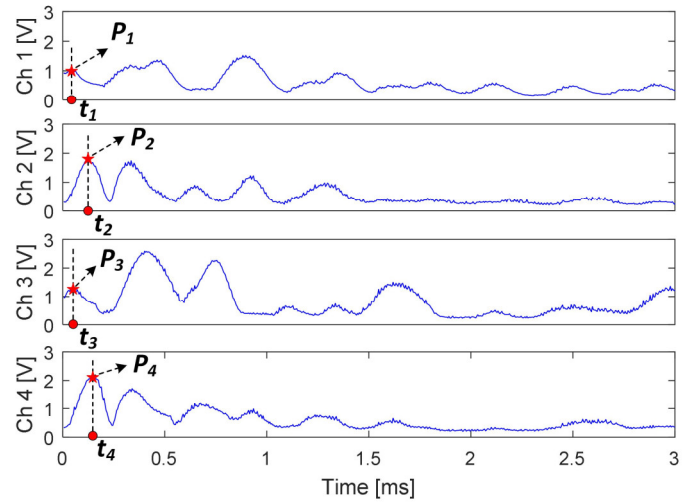

Fig. 5. Multiple channel testing. Four channels (PSs) were adopted in the test. The first channel was used as the trigger channel. Signals recorded by the MCU is illustrated.

location as the trigger signal (automatically chosen by the system according to the signal output) and the rest channels as sensing channel. Sensor numbers, configurations and mounting locations should be optimized to allow the system to be reliably triggered by any channels and also to be able to record the full impact data by the rest of the sensing channels. Also, post-signal processing methods, such as time regression or moving average can be used to recover the lost initial data for the trigger channel.

IV. CONCLUSIONS

In this paper, a novel wireless low-power passive sensing system for impact detection in composite structures is designed and implemented for the first time. The system adopts an event-driven method to allow the system to operate in a low power mode when there are no impacts and to operate with high performance when an impact of significant energy (above a set threshold) occurs. An impact detection circuit was designed to realize the impact-driven method. An MCU with up to 24 input channels was selected for local processing. The whole design was then implemented on a breadboard for prototyping. The system can be miniaturized by integrating all the functions a printed circuit board for practical on-board aircraft monitoring applications. The system exhibits a short wake-up delay of 12 μ s. Impact signals can be reliably recorded in the multiple channel test. The recorded signals from various impacts events where compared to signals recode by oscilloscope. The results show comparable performances but with the proposed system having much lower power consumption and weight. This design provides a baseline for low-power high-response impact monitoring system design.

REFERENCES

- [1] A. Katunin, K. Dragan, and M. Dziendzikowski, "Damage identification in aircraft composite structures: A case study using various non-destructive testing techniques," *Composite Structures*, vol. 127, pp. 1-9, September 2015.

- [2] T. Dursun and C. Soutis, "Recent developments in advanced aircraft aluminium alloys," *Materials & Design*, vol. 56, pp. 862-871, 2014.
- [3] W. J. Staszewski, S. Mahzan, and R. Traynor, "Health monitoring of aerospace composite structures – Active and passive approach," *Composites Science and Technology*, vol. 69, no. 11, 2009.
- [4] G. Hackmann, W. Guo, G. Yan, Z. Sun, C. Lu, and S. Dyke, "Cyber-Physical Codesign of Distributed Structural Health Monitoring with Wireless Sensor Networks," *IEEE Transactions on Parallel and Distributed Systems*, vol. 25, no. 1, pp. 63-72, 2014.
- [5] M. Hong, Q. Wang, Z. Su, and L. Cheng, "In situ health monitoring for bogie systems of CRH380 train on Beijing–Shanghai high-speed railway," *Mech. Syst. Signal Process.*, vol. 45, no. 2, pp. 378-395, 2014.
- [6] R. Di Sante, "Fibre Optic Sensors for Structural Health Monitoring of Aircraft Composite Structures: Recent Advances and Applications," *Sensors*, vol. 15, no. 8, p. 18666, 2015.
- [7] A. B. Noel, A. Abdaoui, T. Elfouly, M. H. Ahmed, A. Badawy, and M. S. Shehata, "Structural Health Monitoring Using Wireless Sensor Networks: A Comprehensive Survey," *IEEE Communications Surveys & Tutorials*, vol. 19, no. 3, pp. 1403-1423, 2017.
- [8] K. Diamanti and C. Soutis, "Structural health monitoring techniques for aircraft composite structures," *Progress in Aerospace Sciences*, vol. 46, no. 8, pp. 342-352, October 2010.
- [9] M. H. Aliabadi and Z. S. Khodaei, *Structural Health Monitoring for Advanced Composite Structures (Computational and Experimental Methods in Structures)*. World Scientific Publishing Europe Ltd., 2018.
- [10] S. K. Seth, S. M. Spearing, and S. Constantinos, "Damage detection in composite materials using Lamb wave methods," *Smart Materials and Structures*, vol. 11, no. 2, p. 269, 2002.
- [11] Z. Sharif-Khodaei and M. Aliabadi, "Assessment of delay-and-sum algorithms for damage detection in aluminium and composite plates," *Smart materials and structures*, vol. 23, no. 7, p. 075007, 2014.
- [12] Z. Sharif Khodaei and M. Aliabadi, "A Multi-Level Decision Fusion Strategy for Condition Based Maintenance of Composite Structures," *Materials*, vol. 9, no. 9, p. 790, 2016.
- [13] Z. Sharif-Khodaei, M. Ghajari, and M. H. Aliabadi, "Determination of impact location on composite stiffened panels," *Smart Materials and Structures*, vol. 21, no. 10, p. 105026, 2012.
- [14] Z. Sharif-Khodaei, M. Ghajari, and M. Aliabadi, "Impact damage detection in composite plates using a self-diagnostic electro-mechanical impedance-based structural health monitoring system." *Journal of Multiscale Modelling*, vol. 6, pp.1550013, 2015.
- [15] M. Ghajari, Z. Sharif-Khodaei, M. Aliabadi, and A. Apicella, "Identification of impact force for smart composite stiffened panels," *Smart Materials and Structures*, vol. 22, no. 8, p. 085014, 2013.
- [16] L. Morse, Z. S. Khodaei, and M. Aliabadi, "Reliability based impact localization in composite panels using Bayesian updating and the Kalman filter," *Mech. Syst. Signal Process.*, vol. 99, pp. 107-128, 2018.
- [17] G. Werner-Allen et al., "Deploying a wireless sensor network on an active volcano," *IEEE Internet Computing*, vol. 10, pp. 18-25, 2006.
- [18] L. Filippini, A. Vitaletti, G. Landi, V. Memeo, G. Laura, and P. Pucci, "Smart City: An Event Driven Architecture for Monitoring Public Spaces with Heterogeneous Sensors," in *2010 Fourth International Conference on Sensor Technologies and Applications*, 2010.
- [19] H. Fu and E. M. Yeatman, "Rotational energy harvesting using bi-stability and frequency up-conversion for low-power sensing applications: Theoretical modelling and experimental validation," *Mechanical Systems and Signal Processing*, 2018, in press, DOI: <https://doi.org/10.1016/j.ymsp.2018.04.043>.
- [20] Z. Sharif-Khodaei, M. Ghajari, and M. H. Aliabadi, "Determination of impact location on composite stiffened panels," *Smart Materials and Structures*, vol. 21, 105026, 2012.
- [21] H. Fu and E.M. Yeatman, "A miniaturized piezoelectric turbine with self-regulation for increased air speed range," *Applied Physics Letters*, vol. 107, p.243905, 2015.
- [22] H. Fu and E. M. Yeatman, "Effective Piezoelectric Energy Harvesting Using Beam Plucking and a Synchronized Switch Harvesting Circuit," *Smart Materials and Structures*, DOI: <https://doi.org/10.1088/1361-665X/aac0b>, 2018, in press.
- [23] H. Fu and E.M. Yeatman, 2017, "A methodology for low-speed broadband rotational energy harvesting using piezoelectric transduction and frequency up-conversion," *Energy*, vol. 125, pp.152-161, 2017.