

Kent Academic Repository

Full text document (pdf)

Citation for published version

Makwana, Arti and Dhont, Kristof and De keersmaecker, Jonas and Akhlagi-Ghaffarokh, Parisa and Masure, Marine and Roets, Arne (2017) The motivated cognitive basis of transphobia: The role of right-wing ideologies and gender role beliefs. Sex Roles . ISSN 0360-0025.

DOI

<https://doi.org/10.1007/s11199-017-0860-x>

Link to record in KAR

<http://kar.kent.ac.uk/64557/>

Document Version

Author's Accepted Manuscript

Copyright & reuse

Content in the Kent Academic Repository is made available for research purposes. Unless otherwise stated all content is protected by copyright and in the absence of an open licence (eg Creative Commons), permissions for further reuse of content should be sought from the publisher, author or other copyright holder.

Versions of research

The version in the Kent Academic Repository may differ from the final published version.

Users are advised to check <http://kar.kent.ac.uk> for the status of the paper. **Users should always cite the published version of record.**

Enquiries

For any further enquiries regarding the licence status of this document, please contact:

researchsupport@kent.ac.uk

If you believe this document infringes copyright then please contact the KAR admin team with the take-down information provided at <http://kar.kent.ac.uk/contact.html>

The Motivated Cognitive Basis of Transphobia:
The Role of Right-Wing Ideologies and Gender Role Beliefs

Arti P Makwana and Kristof Dhont

University of Kent

Jonas De keersmaecker

Ghent University

Parisa Akhlaghi-Ghaffarokh

University of Kent

Marine Masure and Arne Roets

Ghent University

Author Note

Arti P Makwana, School of Psychology, University of Kent; Kristof Dhont, School of Psychology, University of Kent; Jonas De keersmaecker, Department of Developmental, Personality, & Social Psychology, Ghent University; Parisa Akhlaghi-Ghaffarokh, School of Psychology, University of Kent; Marine Masure, Department of Developmental, Personality, & Social Psychology, Ghent University; Arne Roets, Department of Developmental, Personality, & Social Psychology, Ghent University

Correspondence concerning this manuscript should be addressed to Arti Makwana, Keynes College, School of Psychology, University of Kent, Canterbury, CT2 7NP, UK. Email: am2198@kent.ac.uk

Abstract

Transgender individuals challenge the traditional assumption that an individual's gender identity is permanently determined by their assigned sex at birth. Perceiving ambiguity surrounding indeterminate gender identities associated with transgender individuals may be especially disturbing for those who generally dislike ambiguity and have preference for order and predictability, that is, for people scoring higher on Need for Closure (NFC). We tested the associations between NFC and transphobia in two studies using community samples from the United Kingdom (n = 231) and Belgium (n = 175), and we examined whether right-wing ideological attitudes and traditional gender role beliefs mediated these relationships. Confirming our expectations, we found that NFC was significantly associated with transphobia through both stronger adherence to social conventions and obedience to authorities (i.e., right-wing authoritarianism) and stronger endorsements of traditional gender roles in the UK and Belgium, as well as through stronger preferences for hierarchy and social inequality (i.e., social dominance orientation) in the UK. Our results suggest that transgender individuals are more likely to be targets of prejudice by those higher in NFC at least partly due to the strong preference for preserving societal traditions and the resistance to a perceived disruption of traditional gender norms. Hence, attempts to reduce transphobia might be especially challenging among those high in NFC. Nevertheless, prejudice-reducing interventions could incorporate techniques that satisfy epistemic needs for predictability, certainty, and simple structure which may have higher chances of success among high NFC individuals.

Keywords: Transgender (Attitudes Toward); Transphobia; Need for Closure; Ideology; Right-Wing Attitudes; Gender Roles

The Motivated Cognitive Basis of Transphobia:

The Role of Right-Wing Ideologies and Gender Role Beliefs

Transgender individuals are often targets of prejudice as well as victims of discrimination, violence, and harassment (Lombardi, 2009; Stotzer, 2008), with gender nonconforming transgender people reporting more discrimination than gender conforming transgender people (Grant et al., 2010; Miller & Grollman, 2015). The term transgender is an overarching label referring to individuals whose gender identity does not typically align with their assigned sex at birth and encompasses a range of gender identities and expressions (Kuper, Nussbaum, & Mustanski, 2012; Valentine, 2007). This diversity of gender categories may be regarded as ambiguous due to the perceived movement away from heteronormative gender roles, and therefore could arouse discomfort in others (Adams, Nagoshi, Filip-Crawford, Terrell, & Nagoshi, 2016; Garelick, et al., 2017; Stern & Rule, 2017). Whereas some people are perfectly at ease with this disruption to the traditional way of thinking about gender identity, for others it is likely to cause discomfort, fear, and even outright hostility.

People fundamentally differ in their preferences for simple structure and predictability, their general aversion for ambiguity, and their unwillingness to change previously established ideas and knowledge (i.e., being closed- vs. open-minded). These psychological needs and desires are captured by the construct of Need for Closure (NFC), a general epistemic motivation that influences the way people think about the world, process information, and formulate judgments (Kruglanski & Webster, 1996; for a review see Roets, Kruglanski, Kossowska, Pierro, & Hong, 2015). This type of motivated information processing can have an impact on attitudes toward other social groups. Indeed, previous research has shown that some people have a greater

tendency to derogate others who deviate from general social categories due to a desire to maintain certainty and order (Roets & Van Hiel, 2011a; Stern, West, & Rule, 2015).

In the current study, we investigated the associations between NFC and transphobia and tested whether social-ideological attitudes and traditional gender role beliefs mediated these relationships. For the purposes of our investigation, we define transphobia as holding negative, prejudicial attitudes toward individuals whose gender identity does not align with their biological sex (Hill & Willoughby, 2005).

Need for Closure as a Motivated Cognitive Basis of Prejudice

Dispositional Need for Closure (NFC, Kruglanski & Webster, 1996; Webster & Kruglanski, 1994) refers to the way people differ in their desire for firm answers as opposed to confusion and ambiguity. The NFC concept was originally developed outside the prejudice research tradition to examine how people make judgments and construct knowledge. For instance, studies have shown that higher levels of NFC enhance the tendency to make judgments based on limited but readily available information and to anchor further judgments on initial assessments (Kruglanski, Webster, & Klem, 1993; Webster & Kruglanski, 1994; Roets et al., 2015). Yet the concept has been particularly useful in the intergroup relations literature, enhancing our understanding of people's judgments of social groups.

More specifically, Roets and Van Hiel (2011a; see also Dhont, Roets, & Van Hiel, 2011) have illustrated how the defining characteristics of NFC are highly comparable to Allport's (1954) seminal ideas on the prejudiced personality. Preferences for order and predictability, aversion toward ambiguity, and elements of close-mindedness are core aspects in both NFC theory and Allport's description of the general cognitive architecture among prejudice-prone individuals. Consistent with this conceptual fit, empirical studies have repeatedly demonstrated

the associations of NFC with blatant and subtle types of prejudice toward ethnic minorities (Dhont, Roets, & Van Hiel, 2013; Roets & Van Hiel, 2006; Van Hiel, Pandelaere, & Duriez, 2004). NFC is also evident in gender-based prejudice by showing positive associations with sexist attitudes toward both men and women (Roets, Van Hiel, & Dhont, 2012). Taken together, these findings suggest that a general, motivated cognitive style (i.e., NFC) underlies negative attitudes toward a host of outgroups, attesting to the notion that “a person’s prejudice is unlikely to be merely a specific attitude to a specific group; it is more likely to be a reflection of his whole habit of thinking about the world” (Allport, 1954, p. 170; also see Roets & Van Hiel, 2011a).

Sexual orientation minority groups such as lesbians, gays, and bisexuals (LGB) may cause particular discomfort among high NFC individuals because these groups do not fit traditional gender and sexuality norms (Note that traditional gender ideals are a fairly recent construct; see Katz, 2007 for a review.) Indeed, anti-LGB prejudice is positively correlated to both traditional gender role beliefs and NFC (Brandt & Reyna, 2010; Mohr & Rochlen, 1999; Tebbe & Moradi, 2012). Yet, one of these gender-relevant groups that may be perceived as the most gender-transgressive and thus create the most ambiguity is arguably transgender individuals (Cragun & Sumerau, 2015), a group compromising a wide range of nontraditional gender identities (Kuper, Nussbaum, & Mustanski, 2012; Valentine, 2007).

Transgender individuals violate society’s traditional gender expectations by challenging the rigid, essentialist view that gender identity is invariably tied to a binary notion of biologically determined sex, which is deeply ingrained in societal norms and practices (Nagoshi, Brzuzy, & Terrell, 2012). Relying on the NFC theory, those relatively higher in NFC should be especially inclined to show higher levels of transphobia because of the perceived violation of gender identity norms and the lack of firm, rigid gender categories. Therefore, we expected that NFC

would be positively associated to transphobia through a stronger endorsement of traditional gender role beliefs. Only a few studies to date have investigated the relations among NFC, traditional gender role beliefs, and transphobia. In particular, Tebbe and colleagues (Tebbe & Moradi, 2012; Tebbe, Moradi, & Ege, 2014) found positive associations between these three variables in two samples of American psychology students. However, these authors did not test for the proposed indirect association of NFC with transphobia through gender role beliefs nor did they consider the mediating role of other key variables such as socio-ideological attitudes.

Need for Closure and Socio-Ideological Attitudes

Scholars have repeatedly argued that, as a general epistemic motivation, NFC is a relatively distal predictor of intergroup outcomes and thus its effect on prejudice occurs largely indirectly, channelled through several psychological mechanisms and particularly through stronger endorsement of right-wing ideological attitudes (Dhont & Hodson, 2014; Roets & Van Hiel, 2011a; Van Hiel et al., 2004). Two concepts that have received the lion's share of attention in this research line are Right Wing Authoritarianism (RWA; Altemeyer, 1981) and Social Dominance Orientation (SDO; Pratto, Sidanius, Stallworth, & Malle, 1994; Sidanius & Pratto, 1999). RWA encompasses conventionalism, authoritarian submission, and authoritarian aggression. SDO is defined as a general preference for group-based hierarchy and social inequality. RWA and SDO are thought to capture two broad attitudinal dimensions of right-wing ideologies: the social-cultural and the economic-hierarchical dimensions, respectively (Duckitt, 2001; Sibley & Duckitt, 2008).

Right-wing ideologies offer well-structured and ordered views about society by resisting changes to social-cultural traditions (i.e., RWA) and supporting clear hierarchical structures between social groups (i.e., SDO) (see Altemeyer, 1998; Duckitt, 2001; Jost, Glaser, Kruglanski,

& Sulloway, 2003). Such ideological belief systems should be particularly attractive for those higher in NFC because these status-quo belief systems directly appeal to their fundamental needs for order and predictability, and they address their aversion for uncertainty and ambiguity (Jost et al., 2003; Onraet, Van Hiel, Roets, & Cornelis, 2011; Roets & Van Hiel, 2011a). Arguably, this is most apparent for the social-cultural aspect of right-wing ideologies (Federico, Ergun & Hunt, 2014; Onraet et al., 2011; Roets et al., 2015). Although positively correlated, both RWA and SDO have consistently emerged as strong and complementary predictors of different types of outgroup prejudice (Cichocka, Dhont, & Makwana, 2017; Ekehammar, Akrami, Gylje, & Zakrisson, 2004; Sibley & Duckitt, 2008; Van Hiel & Mervielde, 2005), including prejudice based on sex and sexual orientation and endorsement of traditional gender roles (Meeusen & Dhont, 2015; Roets et al., 2012; Sibley, Wilson, & Duckitt, 2007; Whitley & Lee, 2000). Completing the picture, several studies further established that RWA and SDO mediate the relation between NFC and outgroup prejudice (Roets & Van Hiel, 2006; Van Hiel et al., 2004; Roets et al., 2012), yet to date such mediated associations are not known to have been tested for transphobia.

Only a handful of studies have shown the associations of RWA (Nagoshi et al., 2008; Norton & Herek, 2013; Warriner, Nagoshi, & Nagoshi, 2013) or SDO (Tebbe, & Moradi, 2012; Tebbe et al., 2014) with transphobia but these studies have investigated RWA and SDO independently and thus without taking into account the variance shared between RWA and SDO when predicting transphobia (Duckitt, 2001; see also Rocco, & Ricolfi, 2005). Therefore, in the current study we tested a model in which both RWA and SDO are simultaneously included as parallel mediators in the association between NFC and transphobia. Furthermore, we also included traditional gender beliefs as a third mediator, in line with the hypothesized indirect

association of NFC with transphobia through gender role beliefs. Because RWA and SDO are considered broad ideological variables and predictors of more specific intergroup beliefs and attitudes such as traditional gender role beliefs, we modelled traditional gender role beliefs as a mediator following the parallel mediation of RWA and SDO.

The Present Research

We tested the proposed mediation model in two separate studies conducted in two different countries (the UK and Belgium) in order to replicate our findings and demonstrate generalizability. Right-wing social-ideological attitudes (i.e., RWA and SDO), followed by traditional gender role beliefs, were modelled as mediating variables in the association between NFC and transphobia. We expected that NFC would be indirectly related to transphobia through stronger endorsement of right-wing social-ideological attitudes as well as through stronger endorsement of traditional gender role beliefs.

We also explored the role of gender in our model because previous research has consistently established gender differences in both attitudinal and socio-ideological measures. More specifically, men have been found to report higher levels of right-wing ideological attitudes, especially SDO (Lippa & Arad, 1999; Sidanius & Pratto, 1999), more support for traditional beliefs regarding gender roles (Brown and Gladstone, 2012; Kerr & Holden, 1996), and greater levels of prejudice toward sexual orientation minorities (MacInnis & Hodson, 2015; Whitley, & Aegisdottir, 2000). That said, we did not anticipate that participants' gender would greatly affect the hypothesized relationships between these variables in our model. Recent research conducted by Roets et al. (2012, p. 357) on the correlates of sexism demonstrated the role of NFC as a "general underlying source of different forms of sexism toward both men and women, regardless of the individual's gender." That is, NFC was associated with sexism toward

both men and women among both male and female respondents, indicating that NFC may have a more substantial impact on attitudes than on gender differences.

Study 1

Participants

The sample for the present study consisted of 250 British adults who were recruited via convenience sampling by undergraduate students. Respondents ($n = 19$) who provided incomplete data were excluded from the study. The final sample consisted of 231 participants; with 90 male and 141 female respondents aged between 18 and 87 ($M = 32.19$, $SD = 14.18$). Of this sample, 205 (89%) participants self-identified as heterosexual, 2 as homosexual, 15 as bisexual, 3 as queer and 6 self-identified as “other.” None of the participants explicitly self-identified as transgender or intersex. With regard to ethnicity, the majority of the sample (206 participants, 89%) self-identified as White/Caucasian/European, 4 identified as Black, 4 as Asian, 7 as Middle Eastern, and 10 as “Other.”

Procedure

Undergraduate psychology students from a university in South East England disseminated the survey through personal email and personal online social network accounts (i.e., Facebook) to people belonging to their extended social network. Participants who were invited to take part in the survey were provided with an anonymous link to an online survey which included the measures used in the current study. Before taking part, participants were informed that the study aimed to examine the possible associations among personality, personal experience, and attitudes toward several social issues and perceptions toward various group, and they were asked to give their informed consent if they chose to participate. Scales measuring RWA and SDO were presented first, followed by the NFC scale, transphobia scale, and gender

role belief scale. Upon completion, participants were provided with a debriefing statement and the contact details of the researchers.

Measures

Need for closure. NFC was measured with the 15-item short version (Roets & Van Hiel, 2011b) of the NFC scale (Webster & Kruglanski 1994; revised by Roets & Van Hiel, 2007). Sample items include “I don’t like to go into a situation without knowing what I can expect from it” and “I would quickly become impatient and irritated if I would not find a solution to a problem immediately.” Respondents completed the items on a 7-point scale from 1 (completely disagree) to 7 (completely agree), and responses across items were averaged such that higher scores indicated higher levels of NFC. For this version of the NFC scale, Roets and Van Hiel (2011b) obtained a Cronbach’s alpha of .87 which demonstrates good internal consistency and is comparable to the present study ($\alpha = .86$). Roets and Van Hiel also demonstrated the construct validity of the scale by showing negative correlations with Openness and Need for Cognition and positive correlations with Need for Structure. Predictive validity was established by positive correlations with RWA, SDO, and racial prejudice.

Social dominance orientation. SDO was measured with the short, eight-item version of the SDO₇ scale developed by Ho et al. (2015). A sample item reads: “Superior groups should dominate inferior groups.” Respondents indicated their answers on a 7-point scale anchored by 1 (strongly disagree) to 7 (strongly agree). Reverse scored items were recoded, and all items were averaged so that higher scores reflected a greater social dominance orientation. Ho et al. reported Cronbach’s alphas ranging from .78 to .90 for the short version, and in our study, the Cronbach’s alpha was .78. The construct and predictive validity of the scale has been established by strong

positive correlations with a range of policy and intergroup attitudes including support for hierarchy-enhancing jobs, nationalism, and racism (Ho et al.).

Right-wing authoritarianism. We measured RWA with the 12 items of the Authoritarianism-Conservatism-Traditionalism scale of Duckitt, Bizumic, Krauss, and Heled (2010, based on Altemeyer, 1981; Dhont, Hodson, & Leite, 2016). Each item was rated on a 7-point scale where 1 (strongly disagree) and 7 (strongly agree). After recoding reverse-scored items, item scores were averaged with higher scores indicating higher levels of RWA. A sample item included in the scale is “Obedience and respect for authority are the most important virtues children should learn.” Duckitt et al. reported Cronbach’s alphas ranging from .83 to .94 for the full scale. In the present study, the Cronbach’s alpha for the scale was .82 which is comparable to previous research (Dhont et al., 2016). Construct validity has been established by positive correlations with SDO (Dhont et al., 2016) and authoritarian behavior (Duckitt & Bizumic, 2013). Predictive validity has been demonstrated through positive correlations with religiosity, support for greater military force, and right-wing political party support (Duckitt et al., 2010; Van Assche, Dhont, & Pettigrew, 2017).

Traditional gender role beliefs. Traditional gender role beliefs was measured with Brown and Gladstone’s (2012) short, ten-item version of the Gender Role Beliefs Scale (Kerr & Holden, 1996). Sample items include “Women with children should not work outside the home if they don’t have to financially” and “The initiative in courtship should usually come from the man.” Respondents rated the statements on a 7-point scale from 1 (strongly agree) to 7 (strongly disagree), reverse worded items were recoded, and all items were averaged. The item ratings were recoded such that higher scores indicated greater support for traditional gender role ideology. Brown and Gladstone (2012) reported good internal consistency ($\alpha = .81$) which is

comparable to the present study ($\alpha = .84$). Construct validity has been determined by showing significant correlations with attitudes toward women, religiosity, and political ideology, and predictive validity was demonstrated by correlations with attitudes toward lesbians and gays (Brown & Gladstone; Tebbe & Moradi, 2012).

Transphobia. Transphobia was measured using the nine-item Transphobia scale (Nagoshi et al., 2008). Sample items include: “I think there is something wrong with a person who says that they are neither a man nor a woman” and “I believe that a person can never change their gender.” The items are rated on a 7-point scale ranging from 1 (strongly disagree) to 7 (strongly agree), with higher averaged scores reflecting more negative attitudes toward transgender individuals. Nagoshi et al. reported a Cronbach’s alpha of .82 demonstrating high internal consistency, which is comparable to the present sample ($\alpha = .91$). Construct validity has been established by showing positive associations with religious fundamentalism and RWA (Nagoshi et al.) as well as negative attitudes regarding bisexuality and toward lesbians and gays (Tebbe & Moradi, 2012).

Results

Descriptive Statistics and Preliminary Analyses

Means and standard deviations for all measures are presented in Table 1a, along with all zero-order correlations. As expected, NFC was significantly correlated with RWA and SDO and furthermore, NFC, RWA, and SDO were significantly positively correlated with gender role beliefs and transphobia. The correlation between NFC and RWA was significantly stronger than the correlation between NFC and SDO ($z = 3.04$, $p = .002$, based on the correlation difference test, Lee & Preacher, 2013; Steiger, 1980) confirming previous findings (Federico et al., 2014; see also Roets et al., 2015).

Before testing the hypothesized model, we first investigated whether there were any gender differences in the scores on our five key variables. Multivariate analysis of variance showed multivariate gender differences across the five variables, Wilks' $\lambda = .892$, $F(5, 225) = 5.46$, $p < .001$, $\eta^2 = .11$. More specifically, male respondents scored significantly higher on traditional gender role beliefs, $t(229) = -2.23$, $p = .027$, $d = -.29$, on transphobia, $t(229) = -2.62$, $p = .009$, $d = -.35$, and on SDO, $t(229) = -2.86$, $p = .005$, $d = -.38$ (see Table 1). Furthermore, gender differences were found for NFC with higher scores for women than for men, $t(229) = 2.12$, $p = .035$, $d = .28$. For this reason, we included gender as control variable in our analyses.

Mediation Model

To test our hypotheses, we conducted structural equation modelling (SEM) with latent variables to control for measurement error in Mplus (version 7.2, Muthén & Muthén, 1998-2014). We averaged item subsets into three parcels for each latent factor of our key variables to smooth measurement error and maintain an adequate ratio of cases-to-parameters. The measurement models showed a good model fit, $\chi^2(80) = 148.98$, $p < .001$; RMSEA = .061; SRMR = .047; CFI = .97. We tested the hypothesized serial mediation model, in which NFC predicts transphobia via the mediators RWA and SDO, as parallel mediators, followed by gender role beliefs. We included gender as control variable with paths from gender to all other variables. The results of this mediation model are presented in Figure 1.

NFC was significantly associated with both RWA and SDO, which in turn were associated with gender role beliefs. Gender role beliefs was significantly associated with transphobia. The direct paths from RWA and SDO to transphobia were also significant, whereas the direct path from NFC to transphobia was nonsignificant. Next, we estimated the indirect associations of NFC with transphobia. These analyses confirmed that NFC was significantly

indirectly related to transphobia, with a standardized total indirect effect of .22, 95% CI [.122, .323], $p < .001$. Table 2 presents the estimates of all specific indirect effects, confirming that the indirect effect of NFC on transphobia was channelled through RWA and through the specific serial mediation paths of RWA and gender role beliefs as well as through SDO and gender role beliefs. Furthermore, both RWA ($\beta = .13$, 95% CI [.042, .212], $p = .003$) and SDO ($\beta = .13$, 95% CI [.043, .210], $p = .003$) showed significant indirect relations with transphobia through gender role beliefs.

Because we observed some differences in the strength of the zero-order correlations between some of the variables for men and women, we further explored whether gender moderated any of the relations in our hypothesized model by conducting additional SEM tests using manifest variables (centred scores). In this model, gender was tested as a potential moderator by including the interaction terms between gender and each of the predictors or mediators. These analyses revealed that none of the model paths were significantly moderated by gender, all $ps > .05$.

Discussion

The results of Study 1, with a British sample, provided support for our hypothesized model by demonstrating that a general epistemic motivation for order, predictability, and an aversion toward ambiguity was related to negative attitudes toward transgender individuals. Furthermore, this relation was simultaneously mediated by both RWA and SDO, as well as through a stronger endorsement of traditional gender roles. These results indicate that those higher on NFC are more likely to show greater levels of transphobia via increased support for right wing ideologies and traditional gender norms. Our analyses also suggest that these patterns

are similar for both women and men despite mean gender differences on traditional gender role beliefs, transphobia, and both RWA and SDO.

Study 2

Study 1 provided support for the hypothesized model in a community sample from the United Kingdom. The aim of Study 2 was to examine whether our findings would replicate in a different country with a similar social-political environment. Therefore, we tested the same model in a community sample recruited in Belgium; the data for Study 1 and Study 2 were collected within the same 6-month interval. Although the strength of the associations between some of the variables can vary between different countries and contexts (see Cichocka, & Dhont, in press; Rocatto, & Ricolfi, 2005), theoretically, we did not expect marked differences to occur in a Belgian sample as compared to the British sample recruited for Study 1.

Participants.

The sample for Study 2 was collected in the Dutch speaking region of Belgium (i.e., Flanders) and consisted of 236 respondents. After excluding participants who did not disclose their gender or submitted incomplete data ($n = 61$), our final sample consisted of 175 respondents (62 men, 113 women) aged between 16 and 80 ($M = 38.93$, $SD = 16.75$). Within this sample, 170 (97%) participants self-identified as heterosexual, 3 as homosexual, 1 as bisexual and 1 as “Other.” None of the participants explicitly self-identified as transgender or intersex. Participants were also asked to disclose a history of migration in their family background; 170 (97%) participants indicated that they were Belgian nationals without a migration background and 5 stated that they had a history of migration within their family. Comparing the demographic composition of the Belgian sample with the British sample indicated that the samples did not significantly differ in the proportions of male and female respondents, $\chi^2(1) = .530$, $p = .47$. The

mean age of the Belgian sample was, however, higher than the mean age of the British sample, $t(401) = 3.89, p < .001, d = .43$.

Procedure

The procedure for this study was similar to Study 1. Participants were invited to take part in the study via convenience sampling by a graduate student in psychology at a Belgian university. The student advertised the study via personal email and an online social network account (i.e., Facebook). Interested participants were directed to an anonymous link to an online survey. Participants were informed that the survey intended to measure their personal opinion on a number of topics and were asked to give their informed consent before they continued. The Belgian sample was presented with the NFC scale first, followed by RWA and SDO scales, gender role belief scale, and transphobia scale. Upon completion, they were provided with a debriefing statement and the contact details of the researchers.

Measures

Dutch versions of the measures utilized in Study 1 to measure need for closure ($\alpha = .84$), traditional gender role beliefs ($\alpha = .71$), and transphobia ($\alpha = .82$) were used in Study 2. These measures were administered using 7-point scales from 1 (completely disagree) to 7 (completely agree), and responses across items were averaged such that higher scores indicated higher levels of each construct. SDO was measured using the full version of the SDO₇ scale (Ho et al., 2015) used in Study 1. The 16-item scale demonstrated Cronbach's alphas ranging from and .89 to .95 (Ho et al., 2015). In our study, the Cronbach's alpha was .88.

RWA was measured with an abridged 11-item RWA scale (based on Altemeyer, 1981; translated by Meehan, 1991; e.g., Dhont, & Van Hiel, 2009). We acknowledge that an exact replication study would encompass the use of identical measures across both studies. However,

we opted for using a RWA scale that has been validated and frequently used in Belgium rather than using a scale that has not been validated yet in the Belgian context. Van Hiel, Duriez, and Kossowska (2006) reported Cronbach's alphas ranging from .87 to .94 which is comparable to the Cronbach's alpha of the present study ($\alpha = .85$). Moderately strong positive correlations with SDO, conformity, and cultural conservatism indicate construct validity, and correlations with racism and religiosity indicate predictive validity (Duriez & Van Hiel, 2002). It was because of these measurement variations that data were not combined into a single dataset; instead, we conducted separate analyses with British and Flemish participants.

Results and Discussion

Descriptive Statistics and Preliminary Analyses

The pattern of correlations was comparable to that obtained in Study 1. NFC, RWA, and SDO were significantly positively correlated with gender role beliefs and transphobia. NFC was significantly correlated with RWA but was not significantly correlated to SDO in the present study. As in Study 1, the correlations between NFC and RWA were significantly stronger than the correlations between NFC and SDO ($z = 3.78, p < .001$). We also examined possible gender differences in the scores on our five key variables. Multivariate analysis of variance showed multivariate gender differences across the five variables, Wilks' $\lambda = .869, F(5, 169) = 5.08, p < .001, \eta p^2 = .13$. More specifically, male respondents scored significantly higher on traditional gender role beliefs, $t(173) = -3.35, p = .001, d = -.51$, and on transphobia, $t(173) = -4.19, p < .001, d = -.64$ (see Table 1).

Mediation Model

As in Study 1, we tested the hypothesized serial mediation model using SEM with latent variables. The measurement models showed a good model fit, $\chi^2(80) = 144.48, p < .001$;

RMSEA = .068; SRMR = .058; CFI = .95. The results (see Figure 2) showed that NFC was significantly associated with RWA, but not with SDO. Both RWA and SDO showed significant associations with transphobia through gender role beliefs. Furthermore, the direct path from RWA to transphobia was significant, whereas the direct paths from NFC and SDO to transphobia were not significant.

We then estimated the indirect associations of NFC with transphobia. These analyses confirmed that NFC was significantly indirectly related to transphobia, with a standardized total indirect effect of .27, 95% CI [.129, .406], $p < .001$. As shown in Table 2, the estimates of the specific indirect effects showed that the indirect effect of NFC on transphobia was channeled through RWA as well as through the serial mediation including both RWA and gender role beliefs. However, the specific serial mediation path through SDO and gender role beliefs was not significant in our study.

The results of these mediation analyses confirmed the hypothesis that NFC is indirectly related to transphobia through RWA and gender role beliefs. The mediating role of SDO was not confirmed by Study 2, given the nonsignificant path from NFC to SDO. However, echoing Study 1, both RWA ($\beta = .17$, 95% CI [.030, .307], $p = .017$) and SDO ($\beta = .16$, 95% CI [.031, .280], $p = .014$) themselves showed significant indirect relations with transphobia through gender role beliefs. Additional SEM analyses to examine whether gender moderated any of the relations in the hypothesized model yielded no significant moderation effects, all $ps > .05$.

In sum, the findings of Study 2 were largely in line with Study 1 supporting the idea that NFC is positively related to transphobic attitudes through stronger endorsement of right-wing ideological attitudes and beliefs in traditional gender roles, with the difference that the mediating role of SDO was not confirmed in Study 2. Even though a positive association between NFC

and SDO was revealed, it was not statically significant, which could be affected by the smaller sample size.

Model Comparisons across Countries

In order to explicitly compare the mediation model between the British and the Belgian sample and to check whether the small discrepancies in the results would reveal any meaningful (i.e., statistical) differences between the two countries, we conducted multi-group path analyses. Constraining the model paths to be equal across both sample did not significantly worsen the model fit as compared to a model without these constrains, $\Delta\chi^2(10) = 15.20, p = .125$. Also, constraining single paths separately did not reveal significant differences in the strength of any of the paths between the samples, all $\Delta\chi^2(1) < 3.79, ps > .05$. These findings place greater confidence in the generalizability of the findings across the two countries. However, it should be noted that a systematic cross-validation (i.e., exact replication) across samples would require the use of identical measures in both samples. The use of a different RWA measure in the two samples limits the extent to which the mediation model can be fully compared between the two countries, yet was also beyond the scope of the current research.

General Discussion

The results of our two studies showed that a general epistemic motivation for cognitive closure was indirectly related to negative attitudes toward transgender individuals through greater endorsement of right-wing ideologies and traditional gender roles. This finding supports the idea that individuals who may be perceived to contest the notion of absolute, fixed gender identities (i.e., transgender individuals) are more likely targets of prejudice by those who feel discomfort with ambiguity and have a high need for predictability and simple structure (i.e., high NFC individuals). Furthermore, our findings indicate that this relation can at least partly be

explained (i.e., mediated) by stronger endorsement of conventional values and dominance desires, expressed in right-wing ideologies (i.e., RWA and SDO), which in turn drive stronger prescriptive beliefs about appropriate roles and behaviors for men and women.

These insights extend previous literature on the role of motivated information processing and sociopolitical ideology in prejudicial attitudes toward minority groups (Hodson & Dhont, 2015; Roets et al., 2015; Roets & Van Hiel, 2011a) by showing that well-established ideas from work in other intergroup domains also apply to the study of transphobia. Yet, research into transphobia and non-binary gender experiences are relatively recent and most previous studies have been conducted in the United States (e.g., Cragun, & Sumerau, 2015; Garelick et al., 2017; Grant et al., 2010; Miller, & Grollman, 2015; Nagoshi et al., 2012). Our investigation adds to this body of research by addressing attitudes toward transgender people in cultural contexts outside the United States (i.e., in the U.K. and Belgium). Furthermore, previous literature had considered NFC, right-wing attitudes, and traditional gender role beliefs as independent predictors of transphobia (Tebbe, & Moradi, 2012; Tebbe et al., 2014), whereas we conceptually integrated the interrelationships into a mediation model and tested the model in two different countries. This approach allowed us to investigate whether our hypothesized model would hold across two similar cultural contexts. As expected, the results were largely comparable between Study 1 (in the UK) and Study 2 (in Belgium), attesting to the conceptual generalizability of the mediation model.

The Role of Right-Wing Ideologies

In both studies, we obtained evidence for the mediating role of right-wing social ideological attitudes explaining why NFC is associated with gender role beliefs and transphobia. Consistent with previous research, we found that NFC was strongly related to RWA and to a

lesser extent to SDO, with a nonsignificant association between NFC and SDO in the Belgian sample (see also Federico et al., 2014, Van Hiel et al., 2004). These findings confirm that particularly those aspects of right-wing ideologies that emphasize the protection of the social-cultural status-quo (expressed in heightened RWA) are attractive to high NFC individuals. They are thus drawn to the well-structured world views of preserving societal traditions and norms, as well as resisting change, which are typically offered by right-wing authoritarian ideologies. The stronger endorsement of general beliefs about traditional social-cultural norms plays a key role in explaining why NFC is positively associated with specific beliefs about traditional gender roles and, in turn, with transphobia.

Despite the relatively weak relations between NFC and SDO, both samples showed that SDO itself was also indirectly related to transphobia via the mediating role of traditional gender role beliefs. Thus, individuals with a relatively stronger desire to maintain societal hierarchy and inequality are more likely to derogate transgender individuals, largely due to stronger endorsement of traditional beliefs regarding gender roles. This finding complements previous research demonstrating the role of SDO and gender role beliefs in anti-gay attitudes (MacInnis, & Hodson, 2015; Whitley, & Aegisdottir, 2000) by highlighting that this model not only is applicable to homophobia but is also relevant to transphobia.

Moreover, the effects of SDO were established above and beyond the effects of RWA. This way, our studies support the dual process model of prejudice (Duckitt, 2001) by showing the complementary roles of competitive-driven motives for dominance and superiority (expressed in SDO), on the one hand, and threat-driven motives for social control and conformity (expressed in RWA), on the other hand, in predicting transphobia. To the best of our knowledge, the current studies are the first to show the simultaneous relations of both RWA and SDO with

transphobia because previous research only examined these concepts independently from each other (e.g., Tebbe & Moradi, 2012; Tebbe et al., 2014; Warriner et al., 2013; Willoughby et al., 2010). The results thus extend previous evidence that these two distinct ideological attitudes are reliable and consistent predictors of a range of negative outgroup attitudes (Cichocka et al., 2017; Duckitt, 2001; Ekehammar et al., 2004; Meeusen, & Dhont, 2015; Sibley & Duckitt, 2008).

Limitations and Future Research Directions

The aim of our studies was to test the direct and indirect associations between NFC and transphobia through several mediating processes. However, although the order of the variables in our model was strongly grounded in theory and previous work, the cross-sectional nature of our data prevents us from drawing causal conclusions. Longitudinal data are needed to shed further light on the causal influence of NFC and ideological attitudes on traditional gender role beliefs and transphobia. Furthermore, given that we relied on self-report measures that may be prone to socially desirable responding, future studies would benefit from examining implicit transphobic attitudes or from observing participants' behavior toward transgender individuals.

Additional research could also focus on a wider range of cultural contexts and include countries with higher levels of intolerance toward people who identify as transgender. Our studies were conducted in western European countries where people may be considered as more accepting of variations in gender identities as compared to some other regions in the world (Winter et al., 2009). Cross-cultural research designs would allow for testing possible interactions between individual- and country-level predictors of attitudes toward transgender individuals (e.g., Donaldson, Handren, & Lac, 2017).

Finally, future research into the role of NFC in transgender attitudes could further differentiate between gender conforming and nonconforming identities and expressions (Grant et

al., 2010; Miller, & Grollman, 2015; Stern, & Rule, 2017; Valentine, 2007) and compare between attitudes toward different sexual orientation and gender minority groups (e.g., homophobia versus transphobia). This would be especially important to the understanding of how variations in gender identity and the considerable variability of those who fall under the transgender umbrella might affect people's views on this diverse group (Worthen, 2013). For instance, Stern and Rule (2017) demonstrated that physical appearance significantly affected conservatives' attitudes toward transgender people because they evaluated androgynous transgender individuals more negatively than those with a more sex-typical appearance. Future research could test whether NFC is more strongly related to transphobia toward transgender people with an androgynous appearance or who are gender nonconforming than toward transgender people with a sex-typical or gender-conforming appearance.

Practice Implications

Overcoming transphobia in those high in NFC is likely to be challenging because NFC is considered to be a fairly stable general motivation inherently characterized by the permanence of existing views (Roets et al., 2015; Roets & Van Hiel, 2011a). That is, those with higher levels of NFC have a propensity to stick to existing attitudes and patterns of thinking in order to protect closure for as long as possible (Kruglanski & Webster, 1996; Roets & Van Hiel, 2006). Therefore, it seems difficult to change their attitudes. That said, previous research has repeatedly demonstrated that positive contact with members of a different group typically reduces outgroup negativity and prejudice in a variety of intergroup settings (see Hodson & Hewstone, 2013; Pettigrew & Tropp, 2006). Intergroup contact interventions could increase predictability, certainty, and familiarity with transgender people (e.g., Walch et al., 2012) and may therefore be particularly efficient in reducing transphobia among those with high NFC. Indeed, such findings

have been established in the context of ethnic prejudice. In a series of studies, Dhont and colleagues (2011) provided correlational and experimental evidence for the particularly beneficial effects of intergroup contact among high NFC individuals (see also Kteily, Hodson, Dhont, & Ho, 2017). Promoting high quality intergroup contact might thus prove to be essential in reducing transphobia among individuals high in NFC, and it constitutes a promising research question that is yet to be addressed by future research.

Conclusion

Recent research highlighted the importance of considering gender nonconformity (Grant et al., 2010; Miller & Grollman, 2015), ambiguity (Garelick et al., 2017), and social categorization (Stern & Rule, 2017) when examining attitudes toward transgender individuals. Our findings contribute to this line of research by demonstrating that the derogation of transgender individuals can be partly linked to a general epistemic motivation characterized by a need for firm answers and the avoidance of confusion and ambiguity. Our studies also extend the body of research demonstrating that epistemic motivation could influence how people view their world and how this may elicit prejudiced attitudes, with right-wing ideological attitudes as intermediating psychological processes (Dhont & Hodson, 2014; Roets & Van Hiel, 2011a; Roets et al., 2015).

References

- Adams, K. A., Nagoshi, C. T., Filip-Crawford, G., Terrell, H. K., & Nagoshi, J. L. (2016). Components of gender-nonconformity prejudice. *International Journal of Transgenderism*, 17, 185-198. <https://doi.org/10.1080/15532739.2016.1200509>
- Allport, G. (1954). *The nature of prejudice*. Reading, MA: Addison-Wesley.
- Altemeyer, B. (1981). *Right-wing authoritarianism*. Winnipeg, Canada: University of Manitoba Press. [https://doi.org/10.1016/S0065-2601\(08\)60382-2](https://doi.org/10.1016/S0065-2601(08)60382-2)
- Altemeyer, B. (1998). The other “authoritarian personality.” *Advances in Experimental Social Psychology*, 30, 47–92.
- Brandt, M. J., & Reyna, C. (2010). The role of prejudice and the need for closure in religious fundamentalism. *Personality and Social Psychology Bulletin*, 36, 715-725. <https://doi.org/10.1177/0146167210366306>
- Brown, M. J., & Gladstone, N. (2012). Development of a short version of the gender role beliefs scale. *International Journal of Psychology and Behavioral Sciences*, 2, 154-158. <https://doi.org/10.5923/j.ijpbs.20120205.05>
- Cichocka, A., & Dhont, K. (in press). The personality bases of political ideology and behavior. In V. Zeigler-Hill & T. K. Shackelford (Eds.), *SAGE handbook of personality and individual differences*. London: SAGE
- Cichocka, A., Dhont, K., & Makwana, A. P. (2017). On self-love and outgroup hate: Opposite effects of narcissism on prejudice via social dominance orientation and right-wing authoritarianism. *European Journal of Personality* 31, 366-384. <https://doi.org/10.1002/per.2114>

- Cragun, R. T., & Sumerau, J. E. (2015). The last bastion of sexual and gender prejudice? Sexualities, race, gender, religiosity, and spirituality in the examination of prejudice toward sexual and gender minorities. *The Journal of Sex Research*, 52, 821-834.
<https://doi.org/10.1080/00224499.2014.925534>
- Dhont, K., & Hodson, G. (2014). Does lower cognitive ability predict greater prejudice? *Current Directions in Psychological Science*, 23, 454-459.
<https://doi.org/10.1177/0963721414549750>
- Dhont, K., Hodson, G., & Leite, A. C. (2016). Common ideological roots of speciesism and generalized ethnic prejudice: The social dominance human-animal relations model (SD-HARM). *European Journal of Personality*, 30, 507-522. <https://doi.org/10.1002/per.2069>
- Dhont, K., Roets, A., & Van Hiel, A. (2011). Opening closed minds: The combined effects of intergroup contact and need for closure on prejudice. *Personality and Social Psychology Bulletin*, 37, 514-528. <https://doi.org/10.1177/0146167211399101>
- Dhont, K., Roets, A., & Van Hiel, A. (2013). The intergenerational transmission of need for closure underlies the transmission of authoritarianism and anti-immigrant prejudice. *Personality and Individual Differences*, 54, 779-784.
<https://doi.org/10.1016/j.paid.2012.12.016>
- Dhont, K., & Van Hiel, A. (2009). We must not be enemies: Interracial contact and the reduction of prejudice among authoritarians. *Personality and Individual Differences*, 46, 172-177.
<https://doi.org/10.1016/j.paid.2008.09.022>
- Donaldson, C. D., Handren, L. M., & Lac, A. (2017). Applying multilevel modeling to understand individual and cross-cultural variations in attitudes toward homosexual people

- across 28 European Countries. *Journal of Cross-Cultural Psychology*, 48, 93-112.
<https://doi.org/10.1177/0022022116672488>
- Duckitt, J. (2001). A dual-process cognitive-motivational theory of ideology and prejudice. *Advances in Experimental Social Psychology*, 33, 41-113.
[https://doi.org/10.1016/S0065-2601\(01\)80004-6](https://doi.org/10.1016/S0065-2601(01)80004-6)
- Duckitt, J., & Bizumic, B. (2013). Multidimensionality of right-wing authoritarian attitudes: Authoritarianism-conservatism-traditionalism. *Political Psychology*, 34, 841-862.
<https://doi.org/10.1111/pops.12022>
- Duckitt, J., Bizumic, B., Krauss, S. W., & Heled, E. (2010). A tripartite approach to right-wing authoritarianism: The authoritarianism-conservatism-traditionalism model. *Political Psychology*, 31, 685-715. <https://doi.org/10.1111/j.1467-9221.2010.00781.x>
- Duriez, B., & Van Hiel, A. (2002). The march of modern fascism. A comparison of social dominance orientation and authoritarianism. *Personality and Individual Differences*, 32, 1199-1213. [https://doi.org/10.1016/S0191-8869\(01\)00086-1](https://doi.org/10.1016/S0191-8869(01)00086-1)
- Ekehammar, B., Akrami, N., Gylje, M., & Zakrisson, I. (2004). What matters most to prejudice: Big five personality, social dominance orientation, or right-wing authoritarianism? *European Journal of Personality*, 18, 463-482.
<https://doi.org/10.1002/per.526>
- Federico, C. M., Ergun, D., & Hunt, C. (2014). Opposition to equality and support for tradition as mediators of the relationship between epistemic motivation and system-justifying identifications. *Group Processes & Intergroup Relations*, 17, 524-541.
<https://doi.org/10.1177/1368430213517273>

- Garelick, A. S., Filip-Crawford, G., Varley, A. H., Nagoshi, C. T., Nagoshi, J. L., & Evans, R. (2017). Beyond the binary: Exploring the role of ambiguity in biphobia and transphobia. *Journal of Bisexuality*, 17, 172-189. <https://doi.org/10.1080/15299716.2017.1319890>
- Grant, J. M., Mottet, L. A., Tanis, J., Herman, J. L., Harrison, J., & Keisling, M. (2010). National transgender discrimination survey report on health and health care. Washington, DC: National Center for Transgender Equality and the National Gay and Lesbian Task Force.
- Hill, D. B., & Willoughby, B. L. (2005). The development and validation of the Genderism and Transphobia Scale. *Sex Roles*, 53, 531-544. <https://doi.org/10.1007/s11199-005-7140-x>
- Ho, A. K., Sidanius, J., Kteily, N., Sheehy-Skeffington, J., Pratto, F., Henkel, K. E., ... Stewart, A. L. (2015). The nature of social dominance orientation: Theorizing and measuring preferences for intergroup inequality using the new SDO7 Scale. *Journal of Personality and Social Psychology*, 109, 1003-1028. <https://doi.org/10.1037/pspi0000033.supp>
- Hodson, G., & Dhont, K. (2015). The person-based nature of prejudice: Individual difference predictors of intergroup negativity. *European Review of Social Psychology*, 26, 1-42. <http://doi.org/10.1080/10463283.2015.1070018>
- Hodson, G., & Hewstone, M. (Eds.). (2013). *Advances in intergroup contact*. London: Psychology Press.
- Jost, J. T., Glaser, J., Kruglanski, A. W., & Sulloway, F. J. (2003). Political conservatism as motivated social cognition. *Psychological Bulletin*, 129, 339-375. <https://doi.org/10.1037/0033-2909.129.3.339>
- Katz, J. (2007). *The invention of heterosexuality*. New York: University of Chicago Press.
- Kerr, P. S., & Holden, R. R. (1996). Development of the Gender Role Beliefs Scale (GRBS). *Journal of Social Behavior and Personality*, 11, 3-16.

- Kruglanski, A. W., & Webster, D. M. (1996). Motivated closing of the mind:" seizing" and "freezing." *Psychological Review*, 103, 263-283. <https://doi.org/10.1037/0033-295X.103.2.263>
- Kruglanski, A. W., Webster, D. M., & Klem, A. (1993). Motivated resistance and openness to persuasion in the presence or absence of prior information. *Journal of Personality and Social Psychology*, 65, 861-876. <https://doi.org/10.1037/0022-3514.65.5.861>
- Kteily, N., Hodson, G., Dhont, K., & Ho, A. (2017) Predisposed to prejudice but responsive to intergroup contact? Testing the unique benefits of intergroup contact across different types of individual differences. *Group Processes & Intergroup Relations*. <https://doi.org/10.1177/1368430217716750>
- Kuper, L. E., Nussbaum, R., & Mustanski, B. (2012). Exploring the diversity of gender and sexual orientation identities in an online sample of transgender individuals. *Journal of Sex Research*, 49, 244-254. <https://doi.org/10.1080/00224499.2011.596954>
- Lee, I. A., & Preacher, K. J. (2013, September). Calculation for the test of the difference between two dependent correlations with one variable in common [Computer software]. <http://quantpsy.org>
- Lippa, R., & Arad, S. (1999). Gender, personality, and prejudice: The display of authoritarianism and social dominance in interviews with college men and women. *Journal of Research in Personality*, 33, 463-493. <https://doi.org/10.1006/jrpe.1999.2266>
- Lombardi, E. (2009). Varieties of transgender/transsexual lives and their relationship with transphobia. *Journal of Homosexuality*, 56, 977-992. <https://doi.org/10.1080/00918360903275393>

- MacInnis, C. C., & Hodson, G. (2015). Why are heterosexual men (vs. women) particularly prejudiced toward gay men? A social dominance theory explanation. *Psychology & Sexuality, 6*, 275-294. <https://doi.org/10.1080/19419899.2014.987684>
- Meeusen, C., & Dhont, K. (2015). Parent–child similarity in common and specific components of prejudice: The role of ideological attitudes and political discussion. *European Journal of Personality, 29*, 585-598. <https://doi.org/10.1002/per.2011>
- Meloen, J. D. (1991). Inventarisatie Nederlandse F-schalen 1959–1990. In P. Scheepers & R. Eisinga (Eds.), *Intolerant en Onderdanig [Intolerant and Submissive]* (pp. 186–222). Nijmegen, Netherlands: ITS.
- Miller, L. R., & Grollman, E. A. (2015). The social costs of gender nonconformity for transgender adults: Implications for discrimination and health. *Sociological Forum, 30*, 809-831. <https://doi.org/10.1111/socf.12193>
- Mohr, J. J., & Rochlen, A. B. (1999). Measuring attitudes regarding bisexuality in lesbian, gay male, and heterosexual populations. *Journal of Counseling Psychology, 46*, 353-369. <https://doi.org/10.1037/0022-0167.46.3.353>
- Muthén, L. K., & Muthén, B. O. (1998–2013). *Mplus user's guide* (6th ed.). Los Angeles, CA: Muthen and Muthen.
- Nagoshi, J. L., Adams, K. A., Terrell, H. K., Hill, E. D., Brzuzy, S., & Nagoshi, C. T. (2008). Gender differences in correlates of homophobia and transphobia. *Sex Roles, 59*, 521-531. <https://doi.org/10.1007/s11199-008-9458-7>
- Nagoshi, J. L., Brzuzy, S. I., & Terrell, H. K. (2012). Deconstructing the complex perceptions of gender roles, gender identity, and sexual orientation among transgender individuals. *Feminism & Psychology, 22*, 405-422. <https://doi.org/10.1177/0959353512461929>

- Norton, A. T., & Herek, G. M. (2013). Heterosexuals' attitudes toward transgender people: Findings from a national probability sample of US adults. *Sex Roles, 68*, 738-753.
<https://doi.org/10.1007/s11199-011-0110-6>
- Onraet, E., Van Hiel, A., Roets, A., & Cornelis, I. (2011). The closed mind: 'Experience' and 'cognition' aspects of openness to experience and need for closure as psychological bases for right-wing attitudes. *European Journal of Personality, 25*, 184-197.
<https://doi.org/10.1002/per.775>
- Pettigrew, T. F., & Tropp, L. R. (2006). A meta-analytic test of intergroup contact theory. *Journal of Personality and Social Psychology, 90*, 751-783. <https://doi.org/10.1037/0022-3514.90.5.751>
- Pratto, F., Sidanius, J., Stallworth, L. M., & Malle, B. F. (1994). Social dominance orientation: A personality variable predicting social and political attitudes. *Journal of Personality and Social Psychology, 67*, 741-763. <https://doi.org/10.1037/0022-3514.67.4.741>
- Roccatto, M., & Ricolfi, L. (2005). On the correlation between right-wing authoritarianism and social dominance orientation. *Basic and Applied Social Psychology, 27*, 187-200.
https://doi.org/10.1207/s15324834basp2703_1
- Roets, A., Kruglanski, A. W., Kossowska, M., Pierro, A., & Hong, Y. (2015). The motivated gatekeeper of our minds: New directions in need for closure theory and research. *Advances in Experimental Social Psychology, 52*, 221-283.
<https://doi.org/10.1016/bs.aesp.2015.01.001>
- Roets, A., & Van Hiel, A. (2006). Need for closure relations with authoritarianism, conservative beliefs and racism: The impact of urgency and permanence tendencies. *Psychologica Belgica, 46*, 235-252. <https://doi.org/10.5334/pb-46-3-235>

- Roets, A., & Van Hiel, A. (2007). Separating ability from need: Clarifying the dimensional structure of the Need for Closure Scale. *Personality and Social Psychology Bulletin*, 33, 266-280. <https://doi.org/10.1177/0146167206294744>
- Roets, A., & Van Hiel, A. (2011a). Allport's prejudiced personality today: Need for closure as the motivated cognitive basis of prejudice. *Current Directions in Psychological Science*, 26, 349-354. doi: 10.1177/0963721411424894
- Roets, A., & Van Hiel, A. (2011b). Item selection and validation of a brief, 15-item version of the Need for Closure Scale. *Personality and Individual Differences*, 50, 90-94. <https://doi.org/10.1016/j.paid.2010.09.004>
- Roets, A., Van Hiel, A., & Dhont, K. (2012). Is sexism a gender issue? A motivated social cognition perspective on men's and women's sexist attitudes toward own and other gender. *European Journal of Personality*, 26, 350-359. <https://doi.org/10.1002/per.843>
- Sibley, C. G., & Duckitt, J. (2008). Personality and prejudice: A meta-analysis and theoretical review. *Personality and Social Psychology Review*, 12, 248-279. <https://doi.org/10.1177/1088868308319226>
- Sibley, C. G., Wilson, M. S., & Duckitt, J. (2007). Antecedents of men's hostile and benevolent sexism: The dual roles of social dominance orientation and right-wing authoritarianism. *Personality and Social Psychology Bulletin*, 33, 160-172. <https://doi.org/10.1177/0146167206294745>
- Sidanius, J., & Pratto, F. (1999). *Social dominance: An intergroup theory of social hierarchy and oppression*. Cambridge University Press: Cambridge, UK.
- Steiger, J. H. (1980). Tests for comparing elements of a correlation matrix. *Psychological Bulletin*, 87, 245-251. <https://doi.org/10.1037/0033-2909.87.2.245>

- Stern, C., & Rule, N. O. (2017). Physical androgyny and categorization difficulty shape political conservatives' attitudes toward transgender people. *Social Psychological and Personality Science*. <https://doi.org/10.1177/1948550617703172>
- Stern, C., West, T. V., & Rule, N. O. (2015). Conservatives negatively evaluate counterstereotypical people to maintain a sense of certainty. *Proceedings of the National Academy of Sciences*, 112, 15337-15342. <https://doi.org/10.1073/pnas.1517662112>
- Stotzer, R. L. (2008). Gender identity and hate crimes: Violence against transgender people in Los Angeles County. *Sexuality Research and Social Policy*, 5, 43-52. <https://doi.org/10.1525/srsp.2008.5.1.43>
- Tebbe, E. N., & Moradi, B. (2012). Anti-transgender prejudice: A structural equation model of associated constructs. *Journal of Counseling Psychology*, 59, 251-261. <https://doi.org/10.1037/a0026990>
- Tebbe, E. A., Moradi, B., & Ege, E. (2014). Revised and abbreviated forms of the Genderism and Transphobia Scale: Tools for assessing anti-trans* prejudice. *Journal of Counseling Psychology*, 61, 581-592. <https://doi.org/10.1037/cou0000043>
- Valentine, D. (2007). *Imagining transgender: An ethnography of a category*. Durham, NC: Duke University Press.
- Van Assche, J., Dhont, K., & Pettigrew, T.F. (2017). The social-psychological bases of far-right support in Europe and the United States. Manuscript under review.
- Van Hiel, A., Duriez, B., & Kossowska, M. (2006). The presence of left-wing authoritarianism in Western Europe and its relationship with conservative ideology. *Political Psychology*, 27, 769-793. <https://doi.org/10.1111/j.1467-9221.2006.00532.x>

- Van Hiel, A., & Mervielde, I. (2005). Authoritarianism and social dominance orientation: Relationships with various forms of racism. *Journal of Applied Social Psychology, 35*, 2323-2344. <https://doi.org/10.1111/j.1559-1816.2005.tb02105.x>
- Van Hiel, A., Pandelaere, M., & Duriez, B. (2004). The impact of need for closure on conservative beliefs and racism: Differential mediation by authoritarian submission and authoritarian dominance. *Personality and Social Psychology Bulletin, 30*, 824-837. <https://doi.org/10.1177/0146167204264333>
- Walch, S. E., Sinkkanen, K. A., Swain, E. M., Francisco, J., Breaux, C. A., & Sjoberg, M. D. (2012). Using intergroup contact theory to reduce stigma against transgender individuals: Impact of a transgender speaker panel presentation. *Journal of Applied Social Psychology, 42*, 2583-2605. <https://doi.org/10.1111/j.1559-1816.2012.00955>
- Warriner, K., Nagoshi, C. T., & Nagoshi, J. L. (2013). Correlates of homophobia, transphobia, and internalized homophobia in gay or lesbian and heterosexual samples. *Journal of Homosexuality, 60*, 1317-1334. <https://doi.org/10.1080/00918369.2013.806177>
- Webster, D. M., & Kruglanski, A. W. (1994). Individual differences in need for cognitive closure. *Journal of Personality and Social Psychology, 67*, 1049-1062. <https://doi.org/10.1037/0022-3514.67.6.1049>
- Whitley, B. E., & Aegisdottir, S. (2000). The gender belief system, authoritarianism, social dominance orientation, and heterosexuals' attitudes toward lesbians and gay men. *Sex Roles, 42*, 947-967. <https://doi.org/10.1023/A:1007026016001>
- Whitley, B. E., & Lee, S. E. (2000). The relationship of authoritarianism and related constructs to attitudes toward homosexuality. *Journal of Applied Social Psychology, 30*, 144-170. <https://doi.org/10.1111/j.1559-1816.2000.tb02309.x>

Willoughby, B. L. B., Hill, D. B., Gonzalez, C. A., Lacorazza, A., Macapagal, R. A., Barton, M.

E., & Doty, N. D. (2010). Who hates gender outlaws? A multisite and multinational evaluation of the Genderism and Transphobia Scale. *International Journal of Transgenderism*, 12, 254–271. <https://doi.org/10.1080/15532739.2010.550821>

Winter, S., Chalungsooth, P., Teh, Y. K., Rojanalert, N., Maneerat, K., Wong, Y. W., ...

Macapagal, R. A. (2009). Transpeople, transprejudice and pathologization: A seven-country factor analytic study. *International Journal of Sexual Health*, 21, 96-118. <https://doi.org/10.1080/19317610902922537>

Worthen, M. G. (2013). An argument for separate analyses of attitudes toward lesbian, gay, bisexual men, bisexual women, MtF and FtM transgender individuals. *Sex Roles*, 68, 703-723. <https://doi.org/10.1007/s11199-012-0155-1>

Table 1

Cronbach's Alphas, Descriptive Statistics, and Correlations among Study Variables in Studies 1 and 2

Variables	α	Total M (SD)	Correlations			
			2	3	4	5
UK, Study 1						
1. NFC	.86	3.71 (0.74)	.37***	.16*	.18**	.26***
2. RWA	.82	3.85 (0.99)	--	.39***	.49***	.47***
3. SDO	.78	2.92 (1.02)		--	.51***	.46***
4. GRB	.84	2.71 (1.02)			--	.54***
5. Transphobia	.91	2.98 (1.36)				--
Belgium, Study 2						
1. NFC	.84	3.54 (0.71)	.41***	.14	.26***	.35***
2. RWA	.85	3.24 (1.04)	--	.50***	.49***	.55***
3. SDO	.88	2.44 (0.94)		--	.43***	.49***
4. GRB	.71	2.14 (0.75)			--	.60***
5. Transphobia	.82	3.01 (1.14)				--

Note. Significant differences were found between the British and Belgian sample for the mean scores in NFC ($p = .016$, $d = .24$), SDO ($p < .001$, $d = .49$), and gender role beliefs ($p < .001$, $d = .62$).

* $p < .05$. ** $p < .01$. *** $p < .001$.

Table 2

Results of Effect Decomposition Analyses for the Indirect Effects of NFC on Transphobia

	Study 1 (United Kingdom)			Study 2 (Belgium)		
	Estimate	p	95% CI	Estimate	p	95% CI
Total indirect effect	.22	< .001	[.122, .323]	.27	< .001	[.129, .406]
Indirect effect via RWA	.11	.007	[.032, .196]	.11	.038	[.006, .204]
Indirect effect via SDO	.04	.071	[-.003, .086]	.02	.228	[-.014, .058]
Indirect effect via GRB	-.02	.486	[-.059, .028]	.04	.372	[-.052, .138]
Indirect effect via RWA and GRB	.06	.009	[.014, .097]	.08	.027	[.009, .141]
Indirect effect via SDO and GRB	.03	.040	[.001, .054]	.02	.164	[-.009, .053]

Note. NFC = Need For Closure; RWA = Right-Wing Authoritarianism; SDO = Social Dominance Orientation; GRB = Gender Role Beliefs

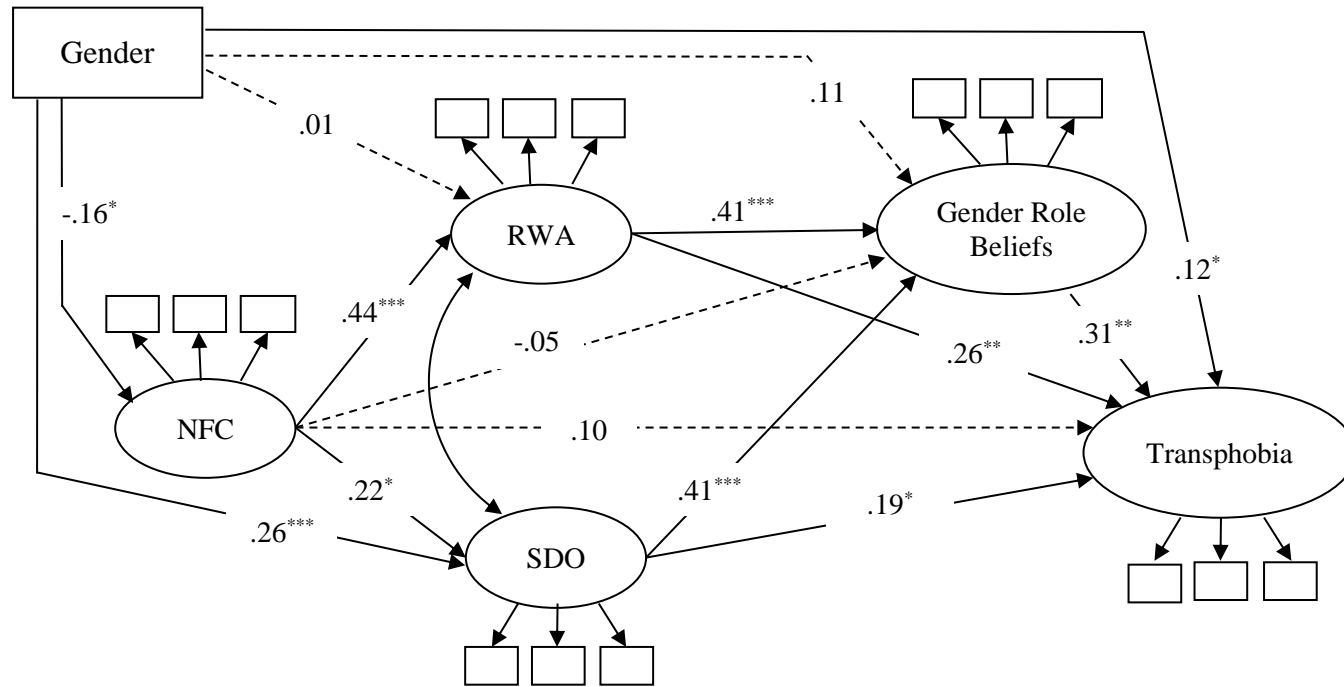

Figure 1. Model results for Study 1 showing the association between need for closure (NFC) and transphobia through right-wing ideologies (RWA and SDO) and traditional gender role beliefs. Solid paths represent significant associations, dashed paths indicate non-significant associations. Disturbance correlation between RWA and SDO was $.46$, $p < .001$. Gender was coded as female = 0, male = 1. $*p < .05$. $**p < .01$. $***p < .001$.

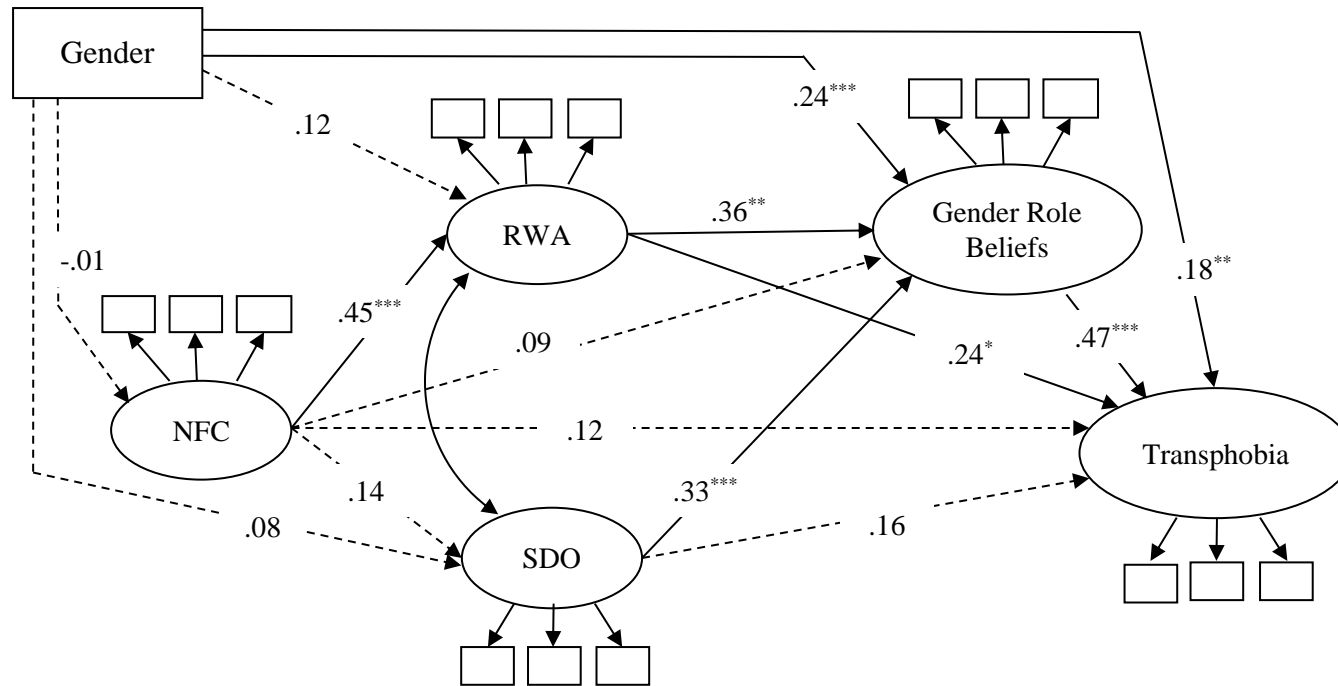

Figure 2. Model results for Study 2 showing the association between need for closure (NFC) and transphobia through right-wing ideologies (RWA and SDO) and traditional gender role beliefs. Solid paths represent significant associations, dashed paths indicate non-significant associations. Disturbance correlation between RWA and SDO was .55, $p < .001$. Gender was coded as female = 0, male = 1. * $p < .05$. ** $p < .01$. *** $p < .001$.

Supplementary Materials

Descriptive Statistics and Correlations for males and females among Study Variables in Studies 1 and 2

Variables	Men M (SD)	Women M (SD)	Correlations				
			1	2	3	4	5
UK, Study 1 (90 men, 141 women)							
1. NFC	3.59 (0.79)	3.80 (0.69)	--	.49***	.24*	.28**	.43**
2. RWA	3.78 (1.09)	3.91 (0.92)	.26**	--	.57***	.59***	.56***
3. SDO	3.15 (1.09)	2.77 (0.94)	.15	.27**	--	.56***	.45***
4. GRB	2.90 (1.01)	2.60 (1.02)	.16	.45***	.45***	--	.55***
5. Transphobia	3.27 (1.55)	2.80 (1.20)	.15	.43***	.44***	.51***	--
Belgium, Study 2 (62 men, 113 women)							
1. NFC	3.52 (0.77)	3.55 (0.68)	--	.49***	.07	.36**	.42**
2. RWA	3.39 (1.18)	3.16 (0.94)	.35***	--	.52***	.47***	.56***
3. SDO	2.53 (0.92)	2.39 (0.95)	.17	.48***	--	.33**	.45***
4. GRB	2.39 (0.88)	2.01 (0.63)	.20*	.47***	.50***	--	.59***
5. Transphobia	3.48 (1.19)	2.76 (1.03)	.33**	.53***	.52***	.55***	--

Note. Correlations for males are reported above the diagonal and correlations for females are reported below the diagonal.

* $p < .05$. ** $p < .01$. *** $p < .001$.