

12-1989

FULL-SCALE VEHICLE CRASH TEST ON THE IOWA STEEL TEMPORARY BARRIER RAIL

Edward R. Post

Ronald K. Faller

University of Nebraska - Lincoln, rfaller1@unl.edu

Brian G. Pfeifer

University of Nebraska - Lincoln

James C. Holloway

University of Nebraska - Lincoln, jholloway1@unl.edu

Follow this and additional works at: <http://digitalcommons.unl.edu/civilengfacpub>

Post, Edward R.; Faller, Ronald K.; Pfeifer, Brian G.; and Holloway, James C., "FULL-SCALE VEHICLE CRASH TEST ON THE IOWA STEEL TEMPORARY BARRIER RAIL" (1989). *Civil Engineering Faculty Publications*. 103.
<http://digitalcommons.unl.edu/civilengfacpub/103>

This Article is brought to you for free and open access by the Civil Engineering at DigitalCommons@University of Nebraska - Lincoln. It has been accepted for inclusion in Civil Engineering Faculty Publications by an authorized administrator of DigitalCommons@University of Nebraska - Lincoln.

**FULL-SCALE VEHICLE CRASH TEST
ON THE
IOWA STEEL TEMPORARY
BARRIER RAIL**



by

Dr. Edward R. Post, P.E.
Professor of Civil Engineering

Mr. Ronald K. Faller, E.I.T.
Research Associate Engineer

Mr. Brian G. Pfeifer, E.I.T.
Research Assistant Engineer

Mr. James C. Holloway
Research Assistant Engineer

submitted to

Mr. William A. Lundquist, P.E.
Bridge Engineer
Iowa Department of Transportation

in cooperation with

Federal Highway Administration - Iowa Division

TRANSPORTATION RESEARCH REPORT TRP-03-20-89

Civil Engineering Department
W348 Nebraska Hall
University of Nebraska-Lincoln
Lincoln, Nebraska 68588-0531

December, 1989

DISCLAIMER STATEMENT

The contents of this report reflect the views of the authors who are responsible for the facts and the accuracy of the data presented herein. The contents do not necessarily reflect the official views or policies of the Iowa Department of Transportation or the Federal Highway Administration. This report does not constitute a standard, specification, or regulation.

ABSTRACT

One full-scale vehicle crash test was conducted on the Iowa Steel Temporary Barrier Rail. Test I5-1 was conducted with at 5,500 pound vehicle at 22.5 degrees and 60.6 mph.

The overall test length of the barrier was 200 feet. The barrier was shop fabricated and transported to the test site in 20 foot length sections. The cross-section of the barrier consisted of two stacked steel HP 14x73 (A36) shapes with the edges of the flanges placed back to back and held together by welded steel straps spaced 5 feet on centers. The inside box section between the HP shapes was filled with concrete. The height of the barrier was 29 inches. The 20 foot length sections were bolted together at the test site.

The location of the vehicle impact was 100 feet from the end of the barrier installation. This was also the location where two sections were bolted together.

The test was evaluated according to the safety criteria in NCHRP 230 and also in the AASHTO guide specifications, performance level 2. The safety performance of the Iowa Steel Temporary Barrier Rail was determined to be satisfactory.

TABLE OF CONTENTS

	Page
Abstract	i
Table of Contents	ii
List of Tables	iv
List of Figures	v
Acknowledgements	vi
1. INTRODUCTION	1
1.1. Problem Statement	1
1.2. Objective of Study	2
2. TEST CONDITIONS	3
2.1. Test Facility	3
2.1.1. Test Site	3
2.1.2. Vehicle Tow System	3
2.1.3. Vehicle Guidance System	3
2.2. Barrier Design Details	7
2.3. Test Vehicle	11
2.4. Data Acquisition Systems	11
2.4.1. Accelerometers	11
2.4.2. High-Speed Photography	14
2.4.3. Speed Trap Switches	18
2.5. Test Parameters	18

	Page
3. PERFORMANCE EVALUATION CRITERIA	19
4. TEST RESULTS	23
4.1. Test No. I5-1	23
5. CONCLUSIONS	31
6. RECOMMENDATIONS	34
7. REFERENCES	35
8. APPENDICES	36
Appendix A. Accelerometer Data Analysis	37
Appendix B. Relevant Subcontractor Correspondence	50

LIST OF TABLES

	Page
1. Criteria to Evaluate Crash Tests on Longitudinal Barriers	20
2. NCHRP 230 Evaluation Criteria	21
3. AASHTO Evaluation Criteria	22
4. NCHRP 230 Evaluation Criteria	32
5. AASHTO Evaluation Criteria	33

LIST OF FIGURES

	Page
1. Full-Scale Crash Test Facility	4
2. Sketch of Cable Tow and Guidance Systems	5
3. Photographs of Tow Vehicles and Fifth Wheel	6
4. Detail Drawing of Temporary Barrier Rail	8
5. Photographs of Barrier Rail Installation	9
6. Photographs of Barrier Rail Before Impact and the Vehicle Guidance System	10
7. Photographs of Test Vehicle Before Impact	12
8. Vehicle Measurements	13
9. Flow Chart of Accelerometer Data Acquisition System	15
10. Data Recorder and 386/AT Computer	16
11. Layout of High-Speed Cameras	17
12. Summary of Test Results	24
13. Time-Sequential Photographs, Test I5-1	25
14. Photographs of Barrier Rail After Impact	27
15. Sketch of Barrier Rail Displacements	28
16. Photographs of Vehicle Damage	30

ACKNOWLEDGEMENTS

The authors wish to express their appreciation and thanks to the following people who made a contribution to the outcome of this research project.

Iowa Department of Transportation

This evaluation task was administered and directed by William A. Lundquist, Bridge Engineer for the Iowa Department of Transportation, who was assisted by IDOT engineers Ron C. Welch and David L. Little.

Federal Highway Administration

The Iowa Division Office of the Federal Highway Administration was represented by Bruce L. Brakke, Division Bridge Engineer, and John M. Latterell, Division Safety Engineer, who cooperated and advised during the evaluation.

University of Nebraska-Lincoln

Ron Hoffman (Electrician - Maintenance)

Michael Cacak (Manager - Automobile Support Services)

Patrick Barrett (Assistant Manager - Automobile Support Services)

James Dunlap (Manager - Photographic Productions)

Gerald Fritz (E.E. Technician)

Tom Grady (E.E. Technician)

William Kelly (Professor and Civil Engineering Chair)

Tom Hoffman (Mechanical Technician)

Syed Ataullah (C.E. PhD Student)

Virgil Oligmueller (C.E. Student)

Craig Rockwell (Work Study)

Mary Lou Tomka (C.E. Administrative Assistant)

Wilma Ennenga (C.E. Research Analyst)

Patricia Pedersen (C.E. Secretary)

Private

Larry Storjahnn (Auto Buyer)

Mike Collins (M.E. Collins Construction)

Steve Buchanan (M.E. Collins Construction)

John Magdaleno (Formerly at UNL, now at General Motors)

1. INTRODUCTION

1.1. Problem Statement

The Iowa Department of Transportation (IDOT) and the Federal Highway Administration (FHWA) are concerned with the safety and structural adequacy of highway and bridge railing systems installed on Iowa highways. The performance of certain Iowa Railing systems, now in service, cannot be predicted nor verified by conventional analysis.

Current AASHTO Standard Specifications for Highway Bridges permits the qualification of railing systems by full-scale vehicle crash testing. The Federal Highway Administration has directed that bridge railing systems be successfully crash tested before their use on Federal Aid Projects is approved.

Space limitations for work, such as repair and rehabilitation on bridge decks, sometimes prevents the use of a full-section New Jersey barrier between the work area and the traveled roadway. Thus, full-scale vehicle crash testing was performed to evaluate the half-scale New Jersey barrier for the possibility of overturning, deflection, and the strength of the connections (1). The safety performance of the Iowa Temporary Concrete Barrier Rail Half-Section was determined to be unsatisfactory.

The unsatisfactory safety performance of the Iowa Temporary Concrete Barrier Rail provoked the need for an alternative temporary barrier rail (1). Thus, a safety performance evaluation was conducted for the Iowa Steel Temporary Barrier Rail.

The results of this study will be used to help guide the IDOT in the use of temporary barriers in the work zone.

1.2. Objective of Study

The objective of the research study was to evaluate the safety performance of the Iowa Steel Temporary Barrier Rail by conducting a full-scale vehicle crash test in accordance with the "Recommended Procedures for the Safety Performance Evaluation of Highway Appurtenances," NCHRP 230 (2) and also in the "Guide Specifications for Bridge Railings," AASHTO (3).

2. TEST CONDITIONS

2.1. Test Facility

2.1.1. Test Site

The test site facility was located at Lincoln Air-Park on the NW end of the west apron of the Lincoln Municipal Airport. The test facility, shown in Figure 1, is approximately 5 mi. NW of the University of Nebraska-Lincoln.

An 8 ft. high chain-linked security fence surrounds the test site facility to ensure that no vandalism would occur to the test articles or test vehicles which could possibly disrupt the results of the tests.

2.1.2. Vehicle Tow System

A reverse cable tow, with a 1:2 mechanical advantage, was used to propel the test vehicle. The distance traveled and speed of the tow vehicle are one-half of that of the test vehicle. A sketch of the cable tow system is shown in Figure 2. The test vehicle was released from the tow cable approximately 18 feet before impact with the Steel Temporary Barrier Rail. Photographs of the tow vehicle and the attached fifth-wheel are shown in Figure 3. The fifth-wheel, built by the Nucleus Corporation, was used for accurately towing the test vehicle at the required target speed with the aid of a digital speedometer in the tow vehicle.

2.1.3. Vehicle Guidance System

A vehicle guidance system, developed by Hinch (4), was used to steer the test vehicle. Photographs of the guidance system are shown in Figure 6; a sketch of the guidance system is shown in Figure 2. The Guide flag, attached to the front left wheel and the guide cable,

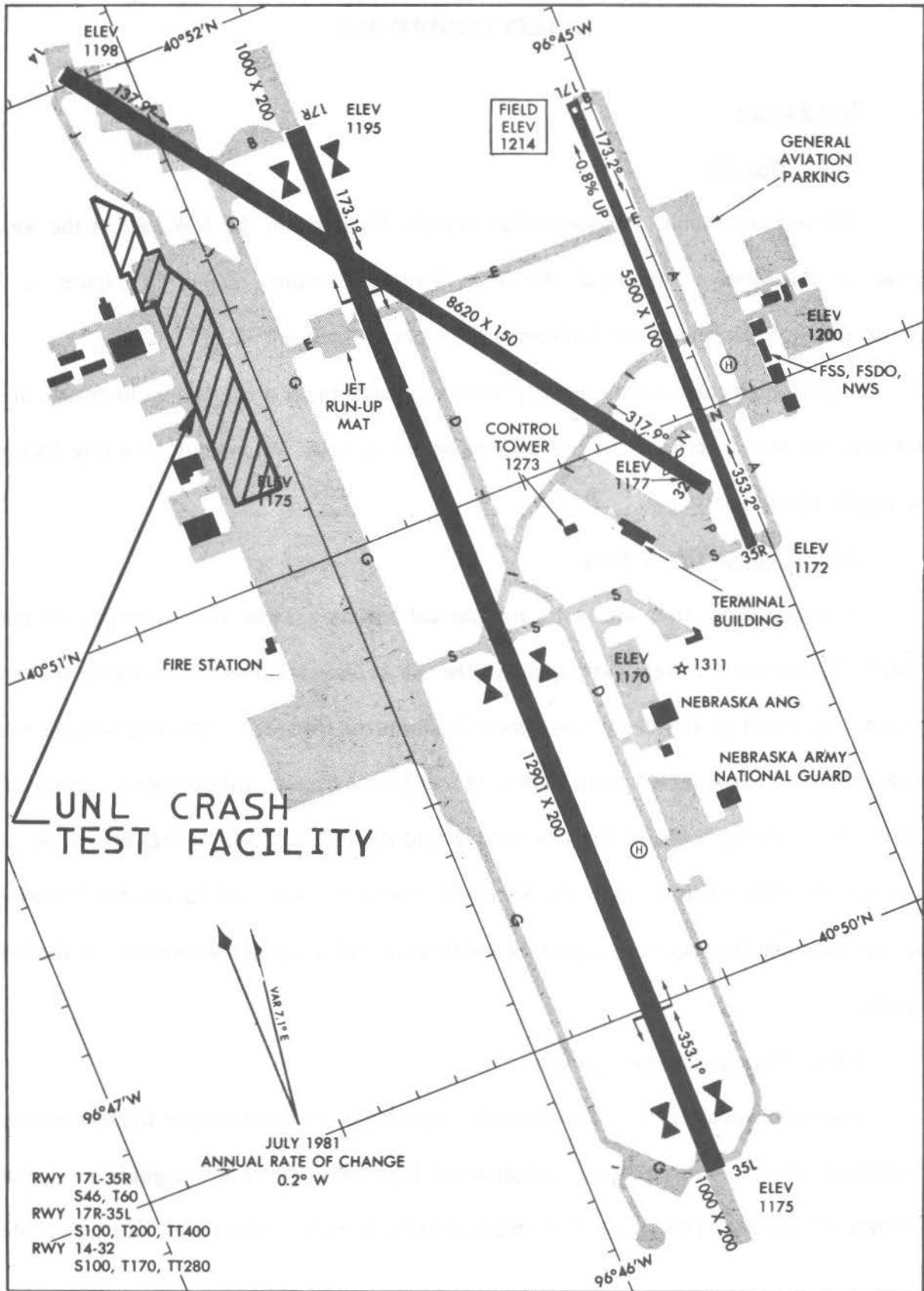

FIGURE 1. FULL-SCALE CRASH TEST FACILITY.

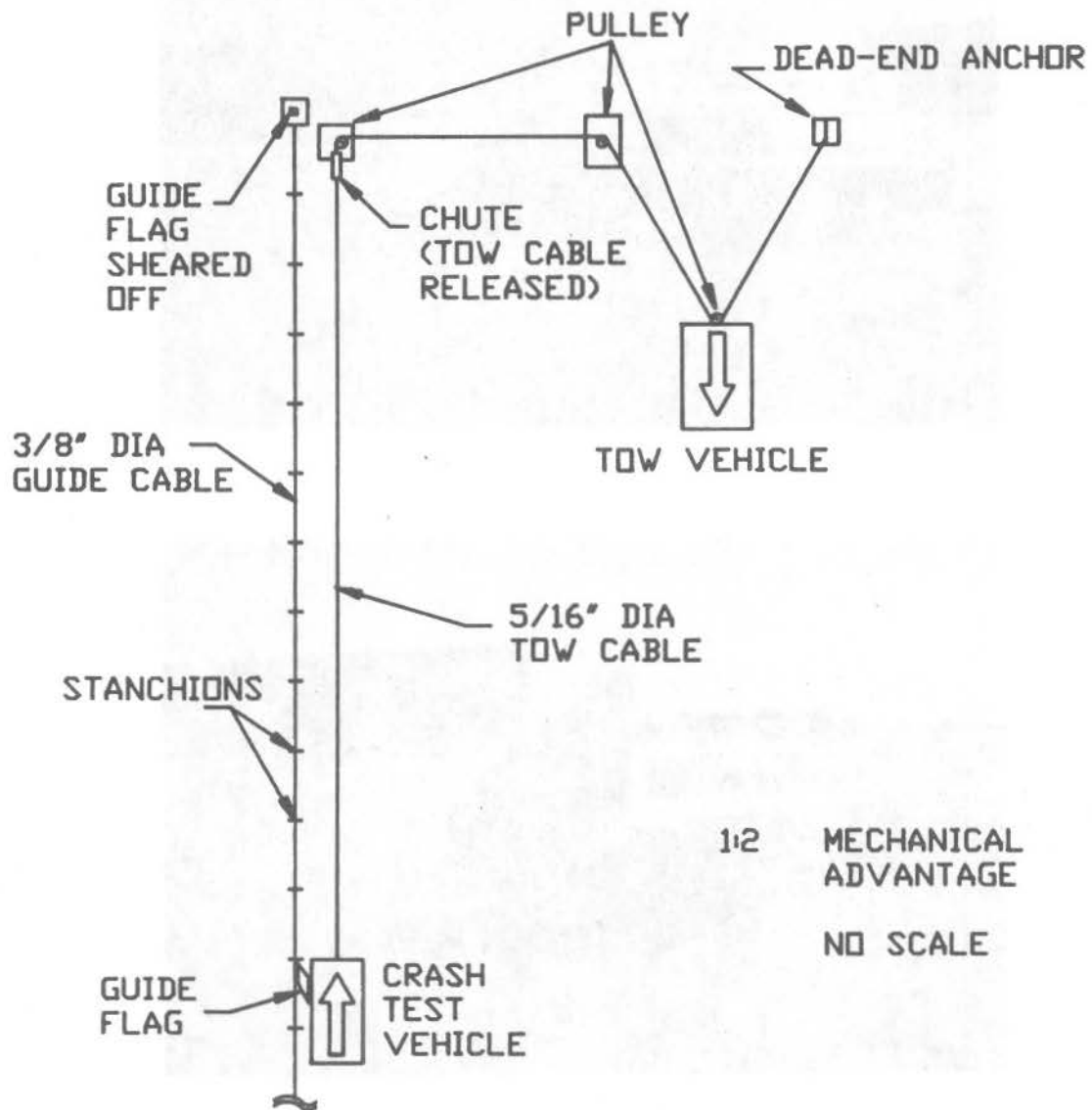

FIGURE 2

SKETCH OF CABLE TOW AND GUIDANCE SYSTEMS

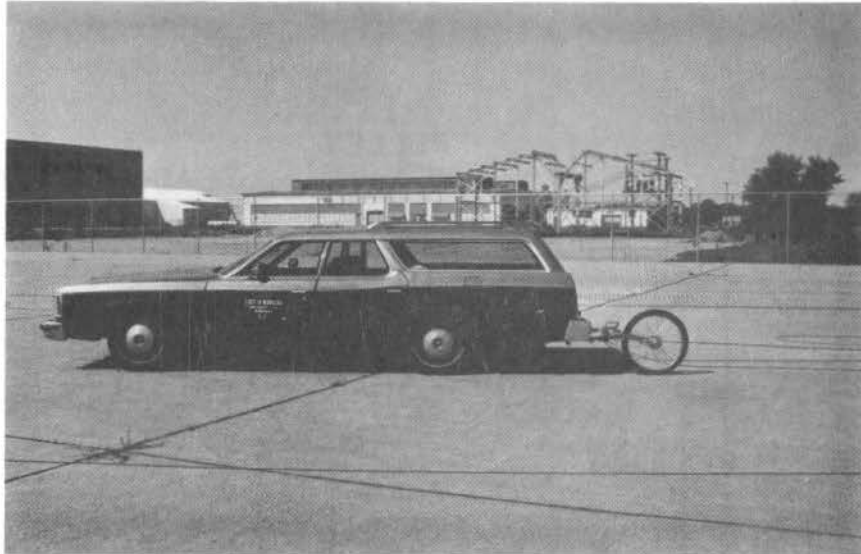

FIGURE 3. PHOTOGRAPHS OF TOW VEHICLE AND FIFTH WHEEL.

was sheared off 18 feet before impact with the Steel Temporary Barrier Rail. The 3/8 in. diameter guide cable was tensioned to 3,000 pounds, and it was supported laterally and vertically every 100 ft. by hinged stanchions. The hinged stanchions stood upright while holding up the guide cable. When the vehicle passed, the guide-flag struck each stanchion and knocked it to the ground. the vehicle guidance system was approximately 1,500 ft. in length.

2.2. Barrier Design Details

The design drawing details of the Iowa steel temporary barrier rail are shown in Figure 4, and photographs of the barrier being installed on the level concrete apron at the test site are shown in Figure 5.

The overall test length of the barrier was 200 feet. The barrier was shop fabricated and transported to the test site in 20 foot length sections. The cross-section of the barrier consisted of two steel, stacked HP14x73 (A36) shapes with the edges of the flanges placed back to back and held together by welded steel straps spaced 5 feet on centers.

In order to increase the weight and stiffness of the barrier, the inside box section between the HP shapes was filled with concrete. The height of the barrier was 29 inches. The 20 foot length sections were bolted together with splice plates at the test site. The fill concrete stopped one foot short of each end of a section.

Photographs of the barrier prior to conducting the test are shown in Figure 6. The barrier was "free-standing" with no attachments to the level concrete apron.

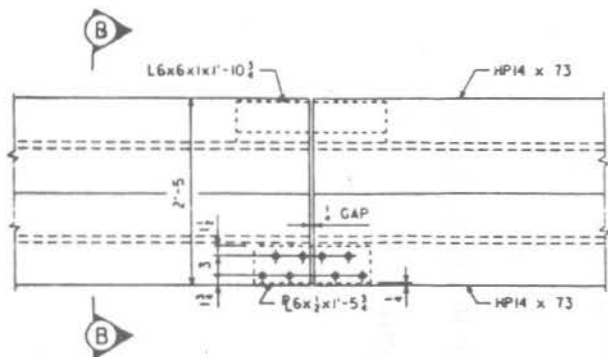

ELEVATION VIEW - TRAFFIC SIDE
(SHOWING CONNECTION AT JOINT)

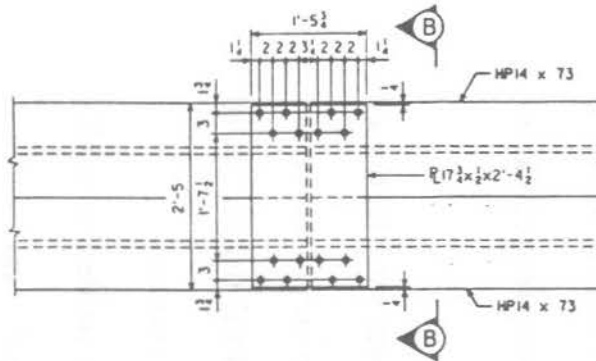

ELEVATION VIEW - WORK AREA SIDE
(SHOWING CONNECTION AT JOINT)

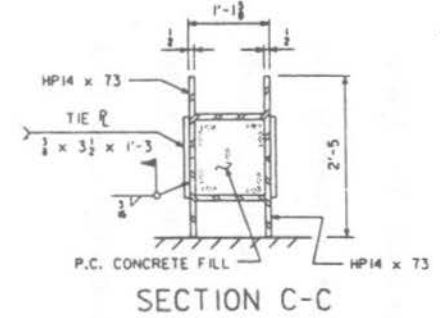

SECTION C-C

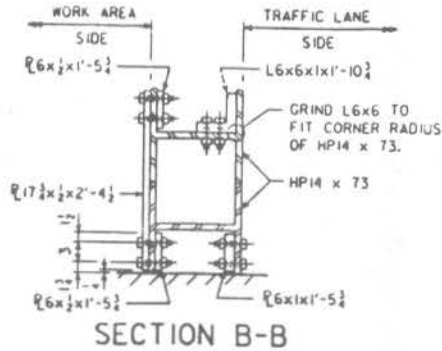

SECTION B-B

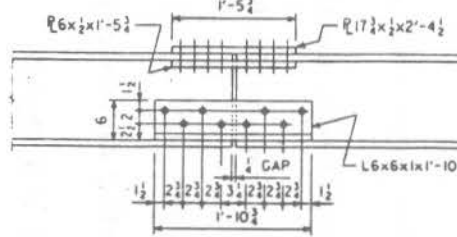

PART PLAN VIEW A-A

NOTES FOR STEEL TEMPORARY BARRIER RAIL:
 HP14x73 SECTIONS ARE TO BE JOINED BEFORE P.C. CONCRETE FILL IS PLACED. HP SECTIONS MAY BE JOINED BY TIE PLATES AS DETAILED OR BY OTHER MEANS APPROVED BY THE ENGINEER. HP SECTIONS SHALL BE FREE FROM EXCESSIVE SWEEP AND CAMBER; STRAIGHTENING MAY BE REQUIRED BY THE ENGINEER IN ORDER TO PRODUCE A STABLE BARRIER.
 CONCRETE MIX FOR THE P.C. FILL MAY BE ANY IOWA D.O.T. HIGHWAY DIVISION SPECIFICATION MIX OR MAY BE A COMMERCIAL READY - MIX WITH A MINIMUM F'C = 2500 P.S.I. THE P.C. FILL MAY BE DEPOSITED BY A METHOD ACCEPTABLE TO THE ENGINEER. JOINTS ARE TO BE REASONABLY MORTAR TIGHT, AND MORTAR EXTRUSIONS SHALL BE CLEANED FLUSH WITH THE OUTSIDE OF THE BARRIER. LIMITS OF FILL SHOWN ARE APPROXIMATE AND MAY BE ROUGH OR SLUMPED DEPENDING ON THE METHOD OF BULK HEADING.
 TACK WELD ALL NUTS TO INSIDE BOTT. 6 x 1 & 6 x 1/2 PLATES AND TACK WELD INSIDE BOTT. 6 x 1 & 6 x 1/2 PLATES TO INSIDE OF THE FLANGE OF THE HP14x73 PILE, ON ONE END OF THE PILE SECTION ONLY. TACK WELD NUTS TO THE INSIDE WEB OF THE TOP PILE FOR THE 6x1 ANGLE CONNECTION.
 1/2" x 1/2" HOLES IN THE 2 INSIDE 6 x 1/2 PLATES, 1 INSIDE 6 x 1 PLATE, THE FLANGES AND WEB OF THE PILE, AND 3/8" x 1/2" HOLES IN THE 17 1/2 x 1/2 OUTSIDE PLATE, AND THE 6 x 1 ANGLE. USE 3/8" x 0'-2 1/2" H. T. S. BOLTS, PROVIDE ONE WASHER PLACED UNDER THE HEAD. BOLTS SHALL BE TIGHTENED SO THAT ALL PLATE FACES BEAR AGAINST EACH OTHER.

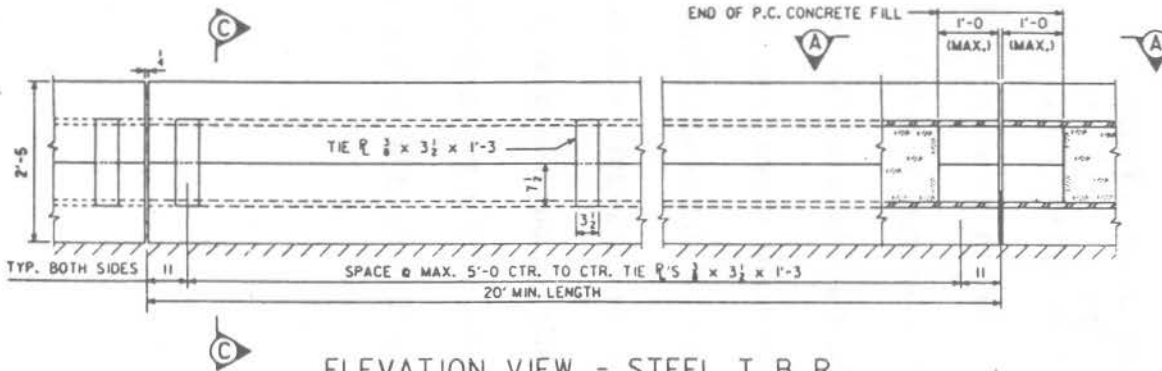

ELEVATION VIEW - STEEL T. B. R.

CRASH TEST
 PROJECT BRF-0005(2)-38-00
TASK NO. 5
APPENDIX A
 PROJECT SHEET 1 OF 7
STEEL TEMPORARY BARRIER RAIL
 IOWA DEPARTMENT OF TRANSPORTATION - HIGHWAY DIVISION

DESIGN SHEET NO. _____	OF _____	FILE NO. _____	DESIGN NO. _____
STATE	SECTION	PROJECT	DATE
IOWA	7		

FIGURE 4. DETAIL DRAWING OF TEMPORARY BARRIER RAIL.

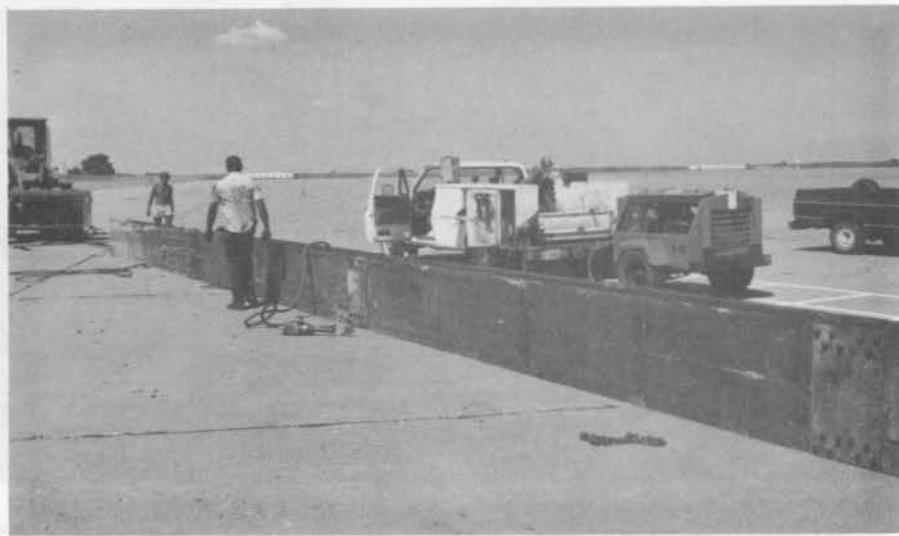

FIGURE 5. PHOTOGRAPHS OF BARRIER RAIL INSTALLATION.

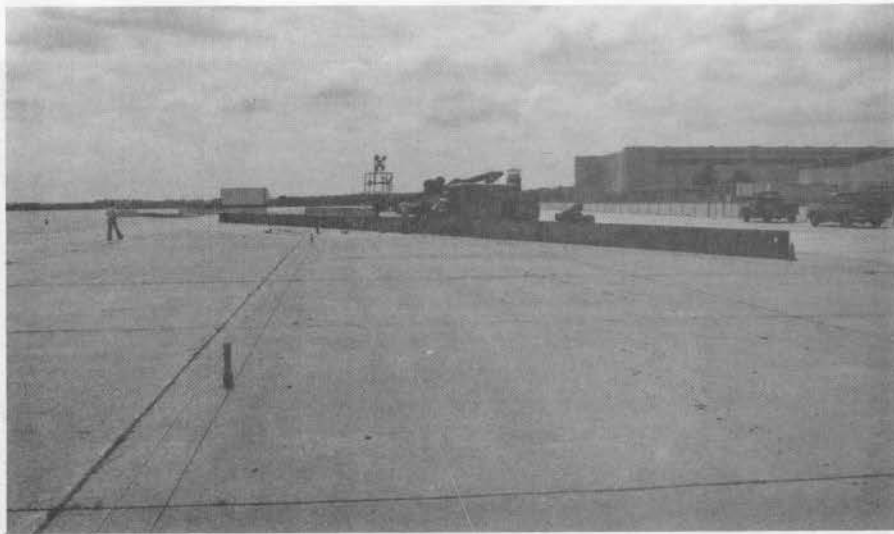

FIGURE 6. PHOTOGRAPHS OF BARRIER RAIL BEFORE IMPACT AND THE VEHICLE GUIDANCE SYSTEM.

2.3. Test Vehicle

The test vehicle was a 1983 3/4-ton Chevrolet (Scottsdale) pickup truck weighing 5,500 pounds. Photographs of the test vehicle are shown in Figure 7, and the physical measurements of the test vehicle are shown in Figure 8.

Steel plates, bolted to the rear box, were used in order for the test vehicle to conform to the weight and the center-of-mass location specifications in AASHTO (3).

Three 8-in. square, black and white checkered targets were placed on the top of the test vehicle. The middle target was placed over the center of mass. Additional roof targets were placed ahead of and behind the center of mass. The targets were used in the analysis of the high speed film. In addition to the roof targets, side and rear targets were placed at known positions to aid in the evaluation process.

Two 5B flash-bulbs were mounted on the roof of the test vehicle to record the time of impact with the bridge rail on the high-speed film. The flash bulbs were fired by a pressure tape switch mounted on the front face of the bumper.

The front wheels of the test vehicle were aligned to a toe-in value of zero-zero so that the vehicle would track properly along the guide cable.

2.4. Data Acquisition Systems

2.4.1. Accelerometers

Six Endevco triaxial piezoresistive accelerometers (Model 7264) with a range of ± 200 g's were used to measure the accelerations in the longitudinal, lateral, and vertical directions of the test vehicle. Two accelerometers were mounted in each of the three directions so that there would be two readings to compare. The accelerometers were rigidly

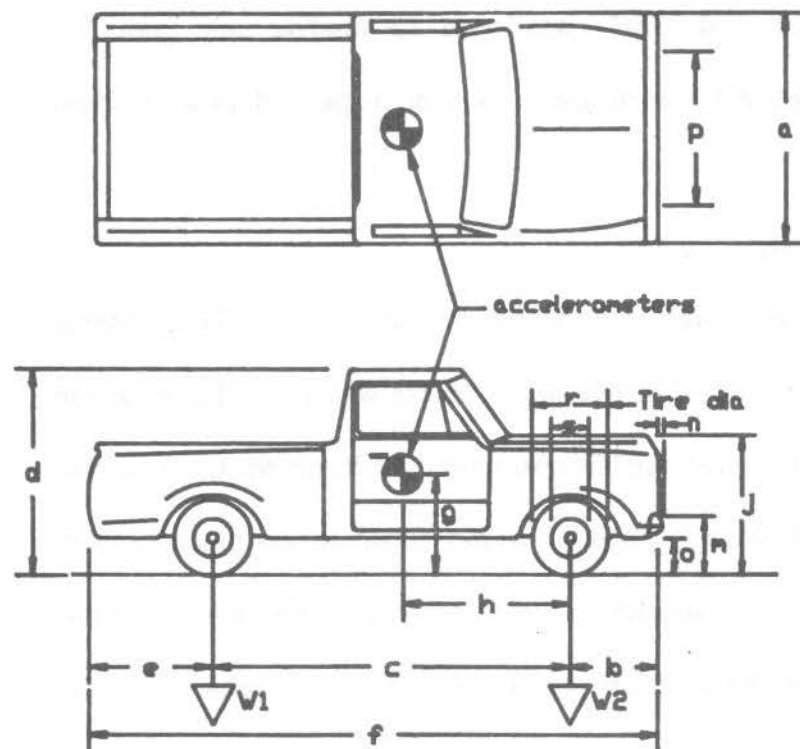

FIGURE 7. PHOTOGRAPHS OF TEST VEHICLE BEFORE IMPACT.

Date: 8/25/89 Test No.: I5-1 Vehicle I.D. #: XXXXXXXXXXXXXXXXXX

Make: Chevrolet Model: Scottsdale 3/4-ton Year: 1983 Odometer: xxxx

Tire Size: 7.5T16LT



Vehicle Geometry - inches

a	78.7	b	33.5
c	132	d	71.6
e	51	f	215.5
g	26	h	64.1
i	NA	j	44.2
k	NA	l	NA
m	27	n	3
o	18	p	66.3
r	29	s	16

Engine Type: V8 Diesel

Engine Size: 6.2 Liter

Transmission Type:

Automatic or Manual

FWD or RWD or 4WD

4 - wheel weight: lf ___ rf ___ lr ___ rr ___

Weight - pounds	Curb	Test Inertial	Gross Static
W1	<u>2060</u>	<u>2670</u>	<u>2670</u>
W2	<u>2890</u>	<u>2830</u>	<u>2830</u>
Wtotal	<u>4950</u>	<u>5500</u>	<u>5500</u>

Note any damage prior to test: None

FIGURE 8. VEHICLE MEASUREMENTS

attached to a metal block mounted at the center-of-mass. The signals from the accelerometers were received and conditioned by an onboard vehicle Metraplex Unit. The multiplexed signal was then radio transmitted to the Honeywell 101 Analog Tape Recorder in the central control van. A flow chart of the accelerometer data acquisition system is shown in Figure 9, and photographs of the system located in the test vehicle and the centrally controlled step van are shown in Figures 7 and 10. The latest state-of-the-art computer software, "Computerscope and DSP", was used to analyze and plot the accelerometer data on a Cyclone 386/AT, which uses a very high-speed data acquisition board.

2.4.2. High-Speed Photography

Three high-speed 16 mm cameras were used to film the crash tests. The cameras operated at approximately 500 frames/sec. The overhead camera was a Red Lake Locam with a wide angle 12.5 mm lens. It was placed approximately 60 ft. above the concrete apron. The parallel camera was a Photec IV with an 80 mm lens. It was placed 250 ft. downstream and offset 3 ft. from a line parallel to the barrier rail. The perpendicular camera was a Photec IV with a 55 mm lens. It was placed 165 ft. from the vehicle point of impact. A schematic of the camera locations is shown in Figure 11.

A 20 ft. wide by 100 ft. long grid layout, shown in Figure 6, was painted on the concrete slab surface parallel and perpendicular to the barrier. The white-colored grid was incremented with 5 ft. divisions in both directions to give a visible reference system which could be used in the analysis of the overhead high-speed film.

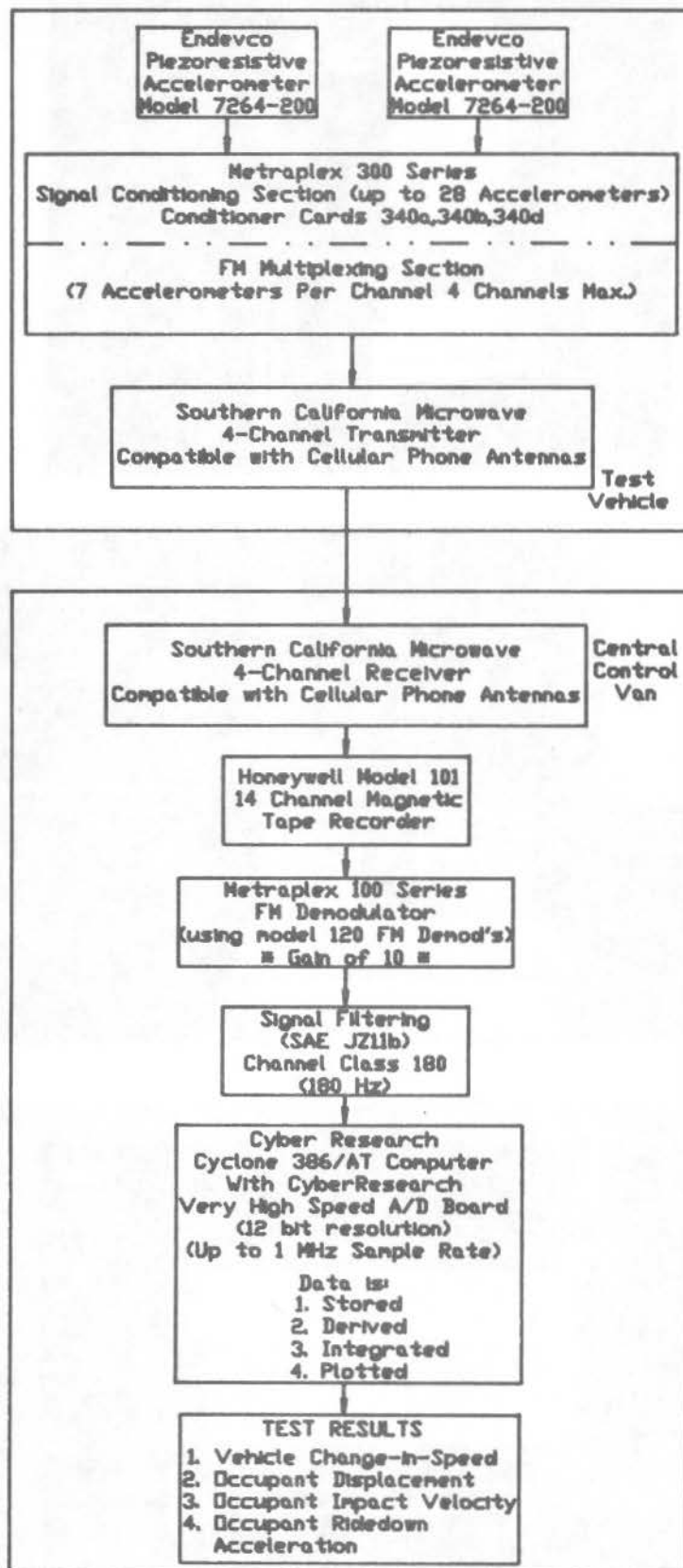

FIGURE 9
FLOW CHART OF ACCELEROMETER
DATA ACQUISITION SYSTEM

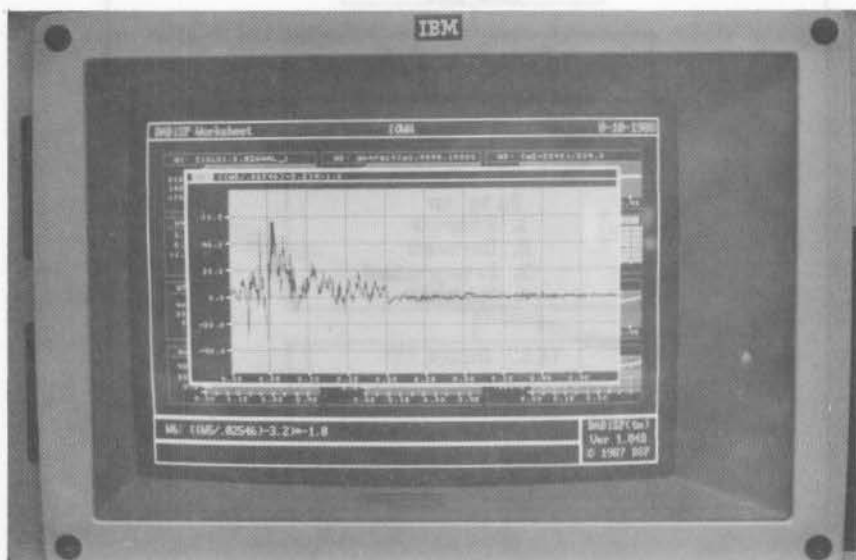
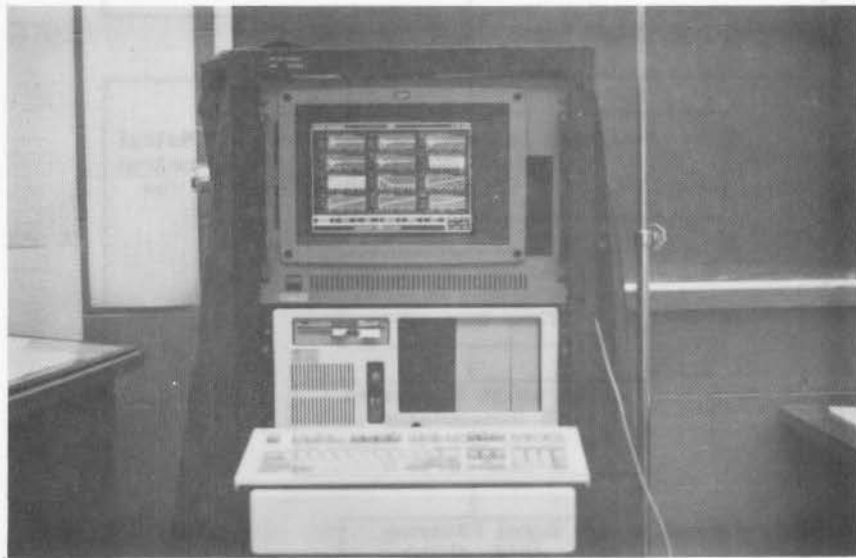
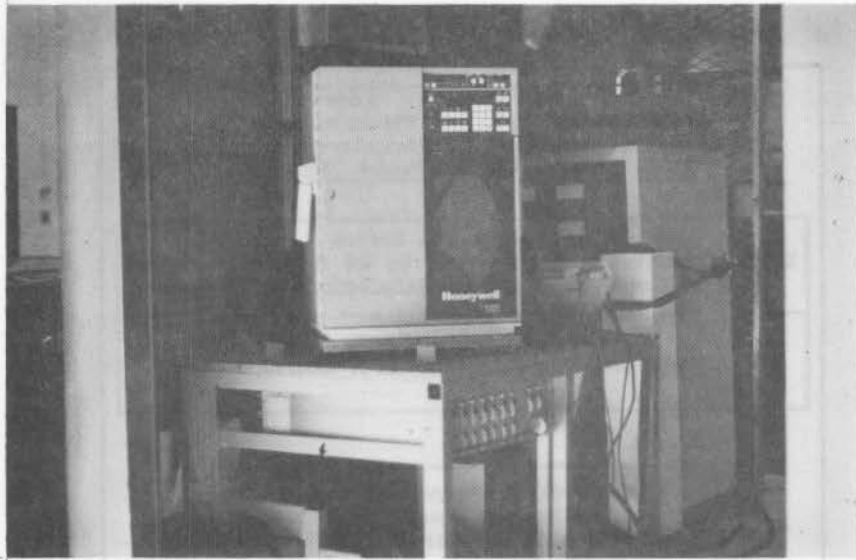
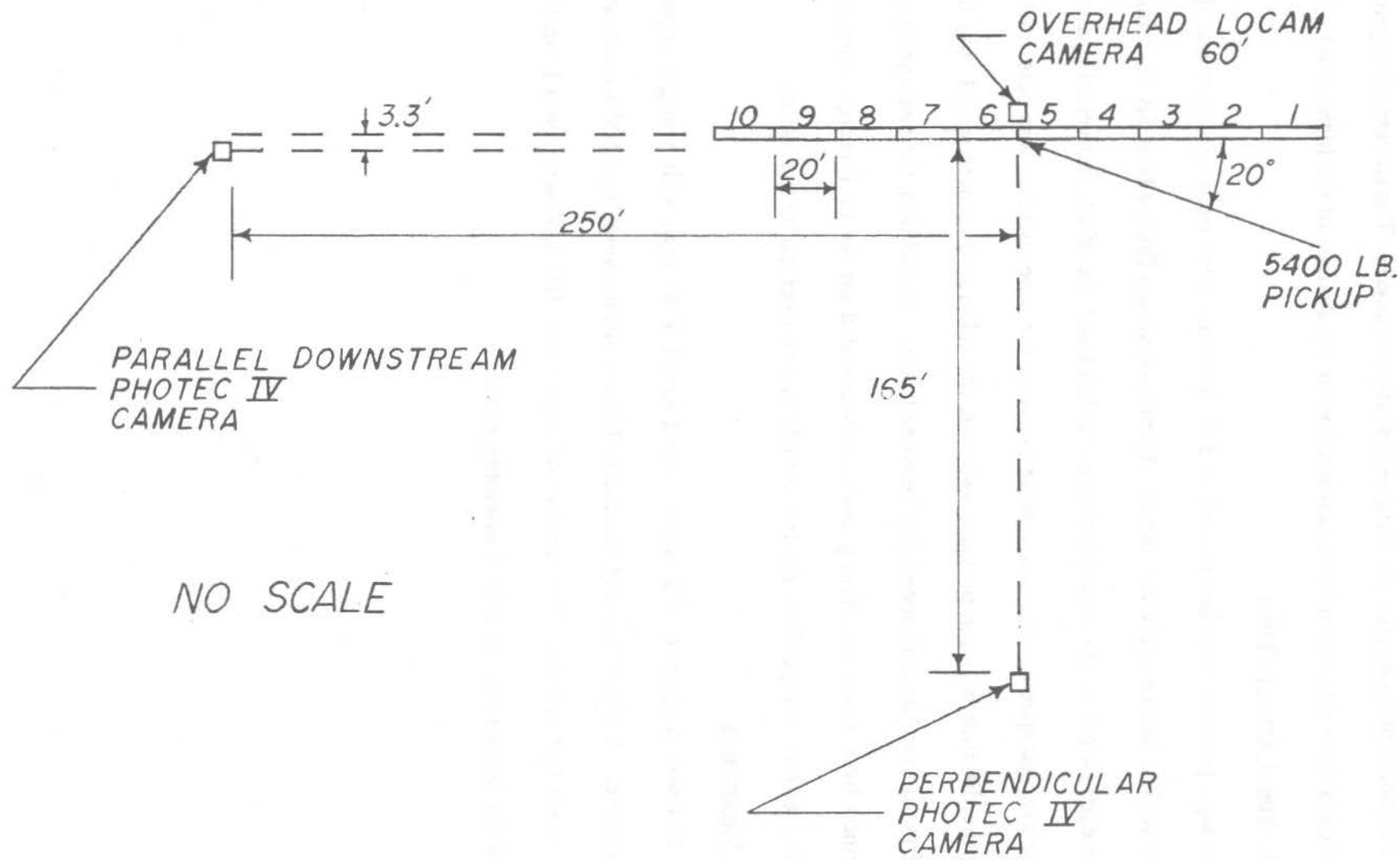

FIGURE 10. DATA RECORDER AND 386/AT COMPUTER.



NO SCALE

FIGURE II. LAYOUT OF HIGH-SPEED CAMERAS

The film was analyzed using the Vanguard Motion Analyzer. The camera divergence correction factors were also taken into consideration in the analysis of the high-speed film.

2.4.3. Speed Trap Switches

Eight tape pressure switches spaced at 5 ft. intervals were used to determine the speed of the vehicle before and after impact. Each tape switch fired a blue 5B flash-bulb located near each switch on the concrete slab as the left front tire of the test vehicle passed over it. The average speed of the test vehicle between the tape switches was determined by knowing the distance between pressure switches, the calibrated camera speed, and the number of frames from the high-speed film between flashes. In addition, the average speed was determined from electronic timing mark data recorded on the oscilloscope software used with the 386/AT computer as the test vehicle passed over each tape switch.

2.5. Test Parameters

Test I5-1 was conducted at a target impact speed of 60 mph with a target impact angle of 20 degrees. A 1983 Chevrolet Scottsdale 3/4-ton pickup weighing 5,500 pounds was used as the crash test vehicle. The location of impact was 100 ft. downstream from the north end of the barrier rail, at a field assembly joint.

3. PERFORMANCE EVALUATION CRITERIA

At the present time, there is no specific criteria for evaluating the safety performance of temporary barrier railings to protect (a) workmen in a bridge construction zone, and (b) the occupants in a run-off-the-road vehicle. However, there are currently two sources of criteria for longitudinal barriers which are similar in many details to temporary barrier railings. The two sources are:

1. NCHRP 230 (2) ... Recommended Procedures for the Safety Performance Evaluation of Highway Appurtenances (1981)
2. AASHTO (3) Guide Specifications for Bridge Railings (1989)

The criteria in AASHTO has been officially adopted by the Federal Highway Administration (FHWA), and the criteria in NCHRP 230 is currently being updated by Ross (5) of the Texas Transportation Institute for use in the year 1992.

The two sources of criteria to evaluate the safety performance of longitudinal barriers are presented in Tables 1, 2, and 3. The selected vehicle impact conditions are most representative of the actual highway conditions in which the Iowa Steel Temporary Barrier Rail will be used. The decision to use the 5,400 pound pickup truck impacting the barrier at 60 mph and 20 degrees was made by the Iowa DOT with approval by the FHWA.

After the test the vehicle damage was assessed by the traffic accident data scale (TAD) (6) and the vehicle damage index (VDI) (7).

It is reasonable to assume that the update of NCHRP 230 will contain specific criteria for construction zone barriers. The specific criteria will mostly include most of the existing criteria with perhaps modifications on (a) the impact speed and angle, and (b) the maximum amount of controlled lateral barrier deflection in item "A" of NCHRP 230 and item "a" of AASHTO.

TABLE 1.

CRITERIA TO EVALUATE CRASH TESTS ON LONGITUDINAL BARRIERS

Test Agency	Test No.	Service Level	Type Barrier Railing	Test Vehicle (lbs)	Impact Conditions			Criteria ¹	
					Speed (mph)	Angle (deg)	Location	Required	Desirable
NCHRP 230	10		Guardrail ² (Length of Need)	4,500 (Sedan)	60	25	Near Splice	A, D, E, H, I	
AASHTO (1989)		PL-2	Bridge ²	5,400 (Pickup)	60	20	Near Splice (NCHRP 230)	3, a, b, c, d	3, e, f, g, h

Notes:

- ¹ Description of criteria in Tables 2 and 3.
- ² Since there are no specific criteria for construction barriers, the criteria for these systems were used to evaluate this test.

TABLE 2. NCHRP 230 EVALUATION CRITERIA

<p>Structural Adequacy</p>	<p>A: Test article shall smoothly redirect the vehicle; the vehicle shall not penetrate or go over the installation although controlled lateral deflection of the test article is acceptable.</p>
	<p>D. Detached elements, fragments or other debris from the test article shall not penetrate or show potential for penetrating the passenger compartment or present undue hazard to other traffic.</p>
<p>Occupant Risk</p>	<p>E. The vehicle shall remain upright during and after collision although moderate roll, pitching, and yawing are acceptable. Integrity of the passenger compartment must be maintained with essentially no deformation or intrusion.</p>
<p>Vehicle Trajectory</p>	<p>H. After collision, vehicle trajectory and final stopping position shall intrude a minimum distance, if at all, into adjacent traffic lanes.</p>
	<p>I. In test where the vehicle is judged to be redirected into or stopped while in adjacent traffic lanes, vehicle speed change during test article collision should be less than 15 mph and the exit angle from the test article should be less than 60 percent of test impact angle, both measured at time of vehicle loss of contact with test device.</p>

TABLE 3. AASHTO EVALUATION CRITERIA

a.	The test article shall contain the vehicle; neither the vehicle nor its cargo shall penetrate or go over the installation. Controlled lateral deflection of the test article is acceptable.												
b.	Detached elements, fragments, or other debris from the test article shall not penetrate or show potential for penetrating the passenger compartment or present undue hazard to other traffic.												
c.	Integrity of the passenger compartment must be maintained with no intrusion and essentially no deformation.												
d.	The vehicle shall remain upright during and after collision.												
e.	The test article shall smoothly redirect the vehicle. A redirection is deemed smooth if the rear of the vehicle does not yaw more than 5 degrees away from the railing from time of impact until the vehicle separates from the railing.												
f.	The smoothness of the vehicle-railing interaction is further assessed by the effective coefficient of friction μ , where $\mu = (\cos\theta - V_p/V)/\sin\theta$. <table style="margin-left: auto; margin-right: auto;"> <thead> <tr> <th style="text-align: center;"><u>μ</u></th> <th style="text-align: center;"><u>Assessment</u></th> </tr> </thead> <tbody> <tr> <td style="text-align: center;">0.0 - 0.25</td> <td style="text-align: center;">Good</td> </tr> <tr> <td style="text-align: center;">0.26 - 0.35</td> <td style="text-align: center;">Fair</td> </tr> <tr> <td style="text-align: center;">>0.35</td> <td style="text-align: center;">Marginal</td> </tr> </tbody> </table>	<u>μ</u>	<u>Assessment</u>	0.0 - 0.25	Good	0.26 - 0.35	Fair	>0.35	Marginal				
<u>μ</u>	<u>Assessment</u>												
0.0 - 0.25	Good												
0.26 - 0.35	Fair												
>0.35	Marginal												
g.	<p>The impact velocity of a hypothetical front-seat passenger against the vehicle interior, calculated from vehicle accelerations and 2.0 ft. longitudinal and 1.0 ft. lateral displacements, shall be less than:</p> <table style="margin-left: auto; margin-right: auto;"> <thead> <tr> <th colspan="2" style="text-align: center;"><u>Occupant Impact Velocity - fps</u></th> </tr> <tr> <th style="text-align: center;"><u>Longitudinal</u></th> <th style="text-align: center;"><u>Lateral</u></th> </tr> </thead> <tbody> <tr> <td style="text-align: center;">30</td> <td style="text-align: center;">25</td> </tr> </tbody> </table> <p>and for the vehicle highest 10-ms average accelerations subsequent to the instant of hypothetical passenger impact should be less than:</p> <table style="margin-left: auto; margin-right: auto;"> <thead> <tr> <th colspan="2" style="text-align: center;"><u>Occupant Ridedown Accelerations - g's</u></th> </tr> <tr> <th style="text-align: center;"><u>Longitudinal</u></th> <th style="text-align: center;"><u>Lateral</u></th> </tr> </thead> <tbody> <tr> <td style="text-align: center;">15</td> <td style="text-align: center;">15</td> </tr> </tbody> </table>	<u>Occupant Impact Velocity - fps</u>		<u>Longitudinal</u>	<u>Lateral</u>	30	25	<u>Occupant Ridedown Accelerations - g's</u>		<u>Longitudinal</u>	<u>Lateral</u>	15	15
<u>Occupant Impact Velocity - fps</u>													
<u>Longitudinal</u>	<u>Lateral</u>												
30	25												
<u>Occupant Ridedown Accelerations - g's</u>													
<u>Longitudinal</u>	<u>Lateral</u>												
15	15												
h.	Vehicle exit angle from the barrier shall not be more than 12 degrees. Within 100 ft. plus the length of the test vehicle from the point of initial impact with the railing, the railing side of the vehicle shall move no more than 20 ft. from the line of the traffic face of the railing.												

4. TEST RESULTS

4.1. Test No. I5-1

A summary of the test results are shown in Figure 12. The test vehicle impacted the barrier at the midspan bolted connection (Joint #5) at a speed of 60.6 mph and an angle of 22.5 degrees. The sequential photographs are shown in Figure 13.

The barrier began to deflect and slide on the concrete apron at a time of 44 msec after impact. At a time of 223 msec., the test vehicle speed decreased to 50.2 mph as it became parallel to the undeformed centerline of the barrier. The test vehicle exited the barrier at a speed of 49.4 mph and at a flat angle of 1.5 degrees.

At a distance of 65 feet from the point of impact, the impact side of the test vehicle reached a maximum rebound distance of 2.0 feet from the traffic face of the barrier. The test vehicle then began to turn rapidly back toward the barrier and crossed over the extended centerline of the barrier at a distance of approximately 122 feet from the point of impact and 22 feet beyond the end of the barrier.

Photographs of the barrier after impact are shown in Figure 14 and a sketch of the displacements of the barrier bolted connections is shown in Figure 15. The maximum displacement of 17 9/16-inches occurred at the point of vehicle impact and connection Joint No. 5. Member 5-6, the first member downstream from the point of impact, was the only member to experience a permanent deformation. This deformation is 1/8-inch.

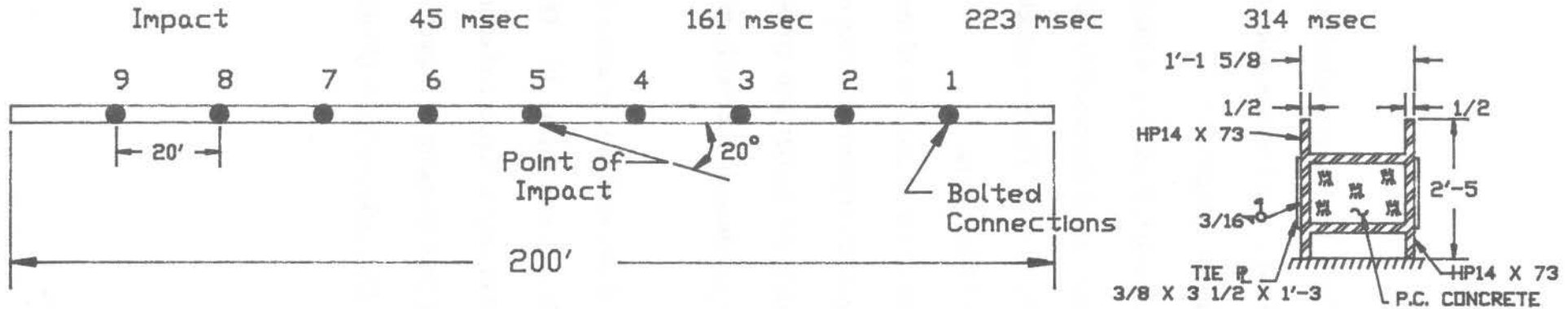
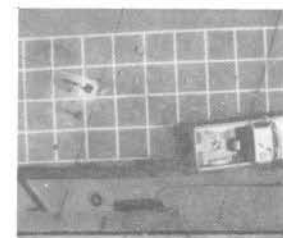
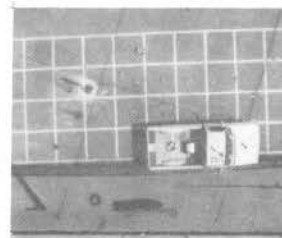
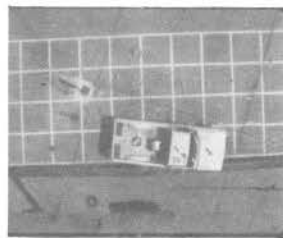
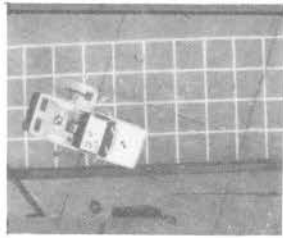

24

Test No.	I5-1	Barrier Damage (deflections)	
Date	8/25/89	Connection (no. 5)	17 9/16 in.
Test Vehicle		Permanent Set (Member 5-6).	1/8 in.
Model	1983 Chev. Pickup	Vehicle Damage	
Weight		TAD	1-RFQ-4
Test Inertia	5,500 lbs.	VDI	01RYEN2
Gross Static	5,500 lbs.	Occupant Impact Velocity	
Impact Conditions		Longitudinal	13.5 fps
Speed	60.6 mph	Lateral	19.6 fps
Angle	22.5 deg.	Occupant Ridedown Decelerations	
Exit Conditions		Longitudinal	+4.7 g's/-6.7 g's
Speed	49.4 mph	Lateral	12.8 g's
Angle	1.5 deg.		
Rebound (max)	2.0 ft @ 65 ft		

FIGURE 12. SUMMARY OF TEST RESULTS



-100 msec



Impact



24 msec



138 msec



225 msec



316 msec

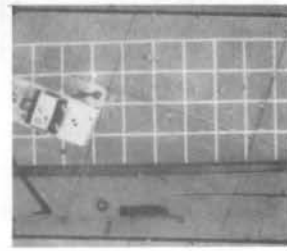

-102 msec

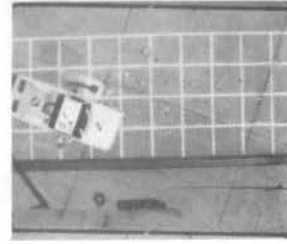

-53 msec



Impact

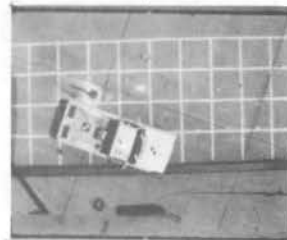

44 msec

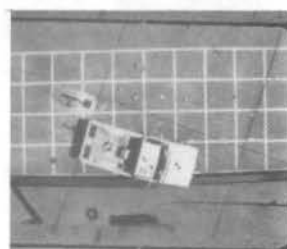

100 msec

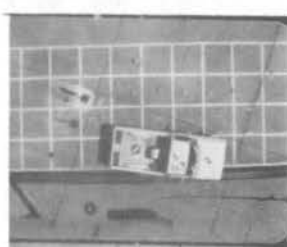

161 msec

FIGURE 13. TIME-SEQUENTIAL PHOTOGRAPHS, TEST I5-1.



440 msec



586 msec



855 msec



1083 msec



1389 msec



1739 msec

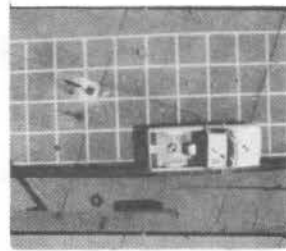

223 msec.

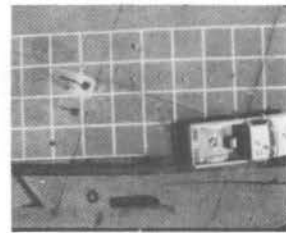

314 msec

FIGURE 13. TIME-SEQUENTIAL PHOTOGRAPHS, TEST I5-1 (cont'd).

FIGURE 12 SKETCH OF BARRIER WITH DISPLACEMENT

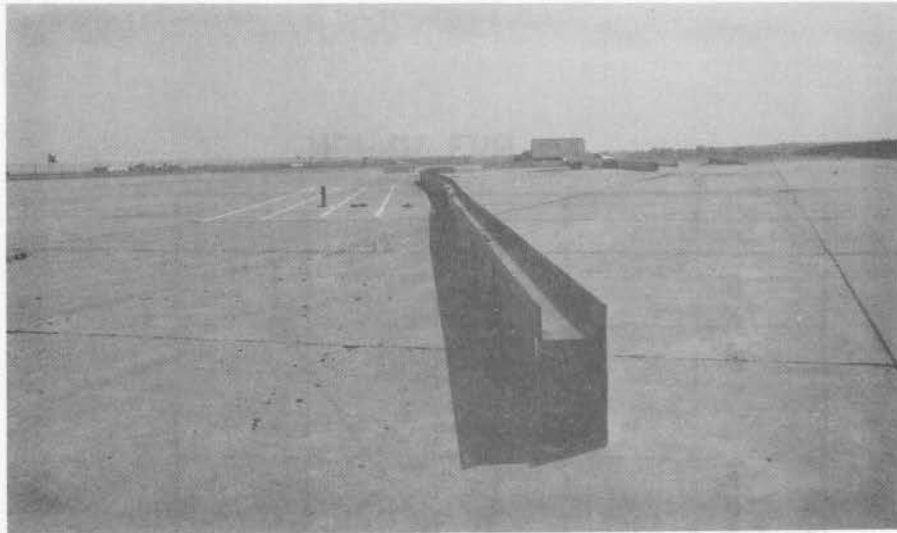

FIGURE 14. PHOTOGRAPHS OF BARRIER RAIL AFTER IMPACT.

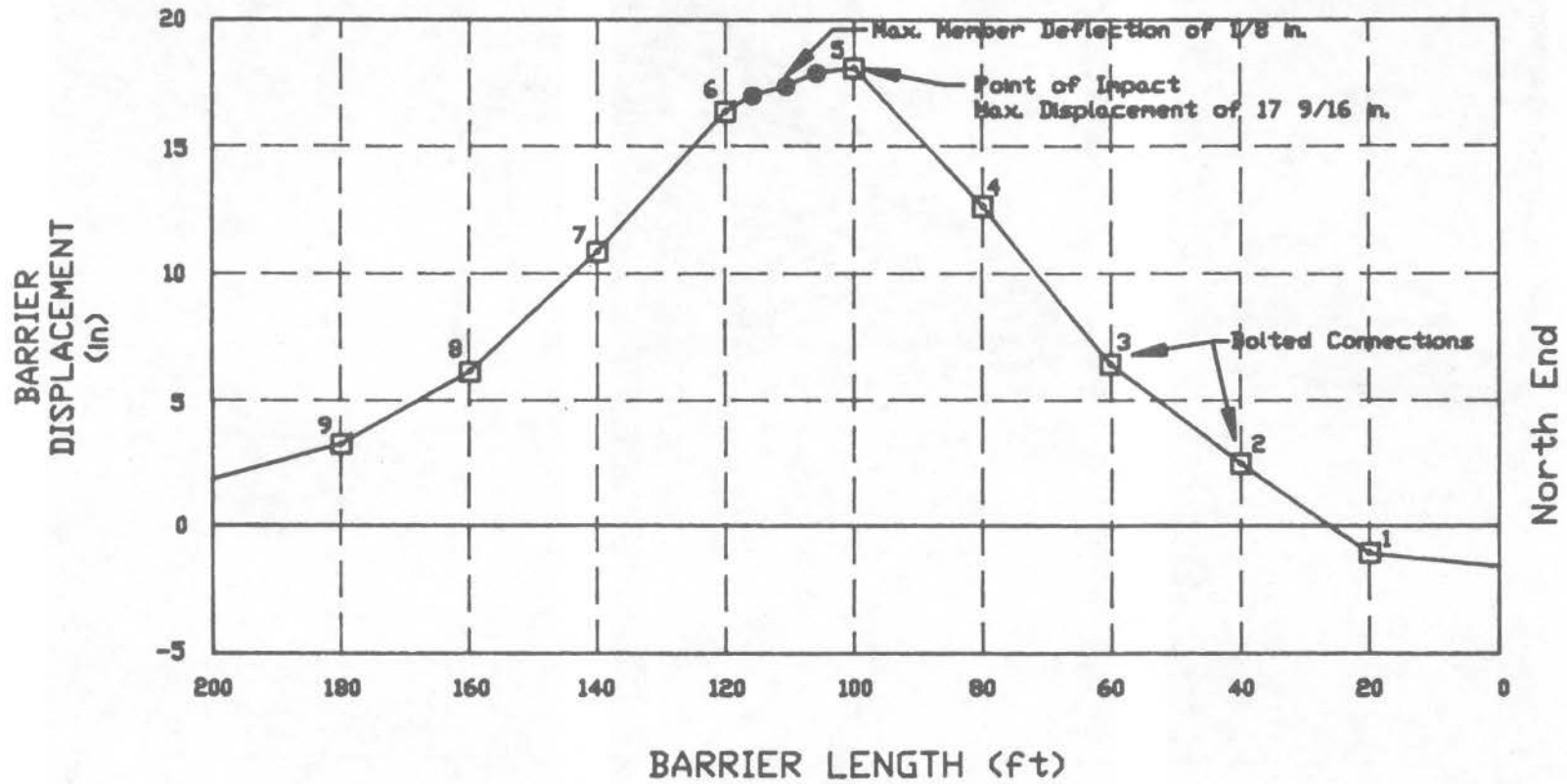

FIGURE 15. SKETCH OF BARRIER RAIL DISPLACEMENTS.

Photographs of the damage to the test vehicle are shown in Figure 16. It is estimated that the test vehicle was traveling at a speed of less than 5 mph when it impacted head-on the previously tested retrofitted concrete barrier that was 200 feet downstream and 24 feet to the right of the steel temporary barrier rail. The inside occupant compartment cab area was intact with no barrier intrusions and essentially no deformation. It appears that the right rear tire and rim were badly damaged due to snagging on several of the 3/8-inch thick welded tie plate straps.

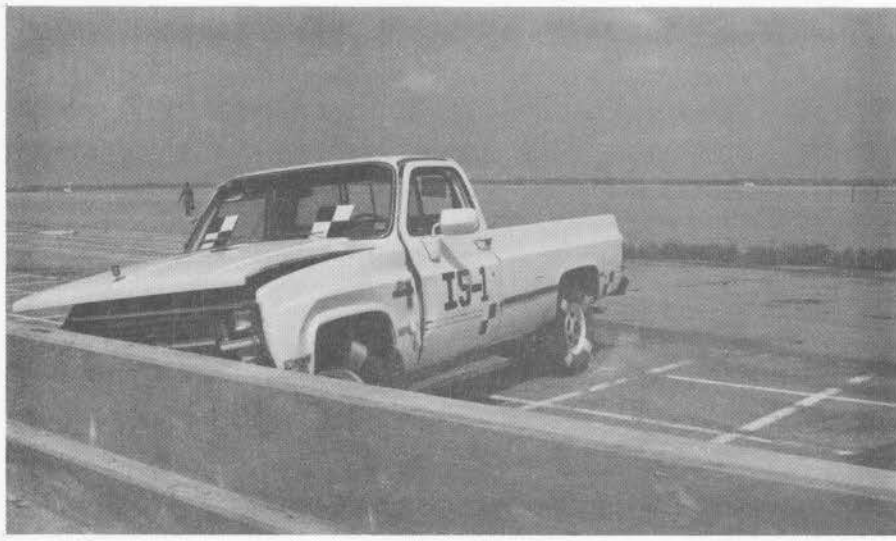

FIGURE 16. PHOTOGRAPHS OF VEHICLE DAMAGE.

5. CONCLUSIONS

One full-scale vehicle crash test was conducted to evaluate the safety performance of the Iowa Steel Temporary Barrier Rail.

Test I5-1 was evaluated according to the safety performance criteria given in NCHRP 230 (2) and AASHTO (3). The safety evaluation summaries using both sets of criteria are presented in Tables 4 and 5.

The analysis of the crash test revealed the following:

1. The temporary barrier smoothly redirected the test vehicle.
2. The test vehicle did not penetrate or ride over the installation.
3. The controlled lateral deflection of the test article was acceptable.
4. There were no detached elements or fragments from the test article which showed potential for undue hazard to other traffic.
5. The integrity of the passenger compartment was maintained.
6. The test vehicle remained upright during and after the collision.
7. The occupant risk values for impact velocity and ridedown decelerations were acceptable during impact.
8. The test vehicle's change in speed was satisfactory (11.20 mph < 15 mph).
9. The test vehicle's trajectory was satisfactory.

Based upon the above listed items, the results of Test I5-1 are acceptable according to the NCHRP 230 (2) and AASHTO (3) guidelines.

TABLE 4. NCHRP 230 EVALUATION CRITERIA

Structural Adequacy	A: Test article shall smoothly redirect the vehicle; the vehicle shall not penetrate or go over the installation although controlled lateral deflection of the test article is acceptable.	S
	D. Detached elements, fragments or other debris from the test article shall not penetrate or show potential for penetrating the passenger compartment or present undue hazard to other traffic.	S
Occupant Risk	E. The vehicle shall remain upright during and after collision although moderate roll, pitching, and yawing are acceptable. Integrity of the passenger compartment must be maintained with essentially no deformation or intrusion.	S
Vehicle Trajectory	H. After collision, vehicle trajectory and final stopping position shall intrude a minimum distance, if at all, into adjacent traffic lanes.	S
	I. In test where the vehicle is judged to be redirected into or stopped while in adjacent traffic lanes, vehicle speed change during test article collision should be less than 15 mph and the exit angle from the test article should be less than 60 percent of test impact angle, both measured at time of vehicle loss of contact with test device.	S

S - Satisfactory
M - Marginal
U - Unsatisfactory

TABLE 5. AASHTO EVALUATION CRITERIA

A R E A		Required	Desirable												
a.	The test article shall contain the vehicle; neither the vehicle nor its cargo shall penetrate or go over the installation. Controlled lateral deflection of the test article is acceptable.	S													
b.	Detached elements, fragments, or other debris from the test article shall not penetrate or show potential for penetrating the passenger compartment or present undue hazard to other traffic.	S													
c.	Integrity of the passenger compartment must be maintained with no intrusion and essentially no deformation.	S													
d.	The vehicle shall remain upright during and after collision.	S													
e.	The test article shall smoothly redirect the vehicle. A redirection is deemed smooth if the rear of the vehicle does not yaw more than 5 degrees away from the railing from time of impact until the vehicle separates from the railing.		S												
f.	The smoothness of the vehicle-railing interaction is further assessed by the effective coefficient of friction μ , where $\mu = (\cos\theta - V_p/V)/\sin\theta$. <table style="margin-left: auto; margin-right: auto;"> <thead> <tr> <th>μ</th> <th>Assessment</th> </tr> </thead> <tbody> <tr> <td>0.0 - 0.25</td> <td>Good</td> </tr> <tr> <td>0.26 - 0.35</td> <td>Fair</td> </tr> <tr> <td>> 0.35</td> <td>Marginal</td> </tr> </tbody> </table>	μ	Assessment	0.0 - 0.25	Good	0.26 - 0.35	Fair	> 0.35	Marginal		Good (0.25)				
μ	Assessment														
0.0 - 0.25	Good														
0.26 - 0.35	Fair														
> 0.35	Marginal														
g.	The impact velocity of a hypothetical front-seat passenger against the vehicle interior, calculated from vehicle accelerations and 2.0 ft. longitudinal and 1.0 ft. lateral displacements, shall be less than: <table style="margin-left: auto; margin-right: auto;"> <thead> <tr> <th colspan="2"><u>Occupant Impact Velocity - fps</u></th> </tr> <tr> <th><u>Longitudinal</u></th> <th><u>Lateral</u></th> </tr> </thead> <tbody> <tr> <td style="text-align: center;">30</td> <td style="text-align: center;">25</td> </tr> </tbody> </table> <p>and for the vehicle highest 10-ms average accelerations subsequent to the instant of hypothetical passenger impact should be less than:</p> <table style="margin-left: auto; margin-right: auto;"> <thead> <tr> <th colspan="2"><u>Occupant Ridedown Accelerations - g's</u></th> </tr> <tr> <th><u>Longitudinal</u></th> <th><u>Lateral</u></th> </tr> </thead> <tbody> <tr> <td style="text-align: center;">15</td> <td style="text-align: center;">15</td> </tr> </tbody> </table>	<u>Occupant Impact Velocity - fps</u>		<u>Longitudinal</u>	<u>Lateral</u>	30	25	<u>Occupant Ridedown Accelerations - g's</u>		<u>Longitudinal</u>	<u>Lateral</u>	15	15		S
<u>Occupant Impact Velocity - fps</u>															
<u>Longitudinal</u>	<u>Lateral</u>														
30	25														
<u>Occupant Ridedown Accelerations - g's</u>															
<u>Longitudinal</u>	<u>Lateral</u>														
15	15														
h.	Vehicle exit angle from the barrier shall not be more than 12 degrees. Within 100 ft. plus the length of the test vehicle from the point of initial impact with the railing, the railing side of the vehicle shall move no more than 20 ft. from the line of the traffic face of the railing.		S												

S - Satisfactory
M - Marginal
U - Unsatisfactory

6. RECOMMENDATIONS

Currently, there is no specific vehicle crash test matrix that addresses temporary construction zone barriers. The 5,400 pound vehicle within the PL-2 performance level of AASHTO (3) has been inherently chosen to be an adequate indicator for safety performance evaluation. This is comparable to the 4,500 pound vehicle within test designation No. 10 of NCHRP 230 (2).

The Iowa steel temporary barrier rail has met the required performance evaluation criteria set forth by NCHRP 230 (1) and AASHTO (2). Thus, it is our recommendation that the Federal Highway Administration approve this installation for use on Federal Aid Projects.

The Iowa Steel Temporary Barrier Rail performed very well. The amount of work required to assemble and disassemble the barrier rail was found to be very time consuming, as stated in Appendix B. This does not promote the design concept of being portable or temporary. When the connection holes were match drilled and oversize drilled (varying between 1/16" and 3/16"), the barrier rail was still time consuming to install on the level concrete apron surface.

After the vehicle had impacted and displaced the barrier rail, removal of the connection bolts was found to be both time consuming and difficult. The time required to assemble and disassemble the barrier rail installation could be reduced if the bolted connections were redetailed.

7. REFERENCES

1. Faller, R.K., Magdaleno, J.A., and Post, E.R. "Full-Scale Vehicle Crash Test on the Iowa Temporary Concrete Barrier Rail Half-Section," Final Report to Iowa Department of Transportation, Report No. TRP-03-014-88, Civil Engineering Department, University of Nebraska-Lincoln, December, 1988.
2. "Recommended Procedures for the Safety Performance Evaluation of Highway Appurtenances," National Cooperative Highway Research Program Report 230, Transportation Research Board, Washington, D.C., March, 1981.
3. "Guide Specifications for Bridge Railings," American Association of State Highways and Transportation Officials, Washington, D.C., 1989.
4. Hinch, J., Yang, T-L, and Owings, R., "Guidance Systems for Vehicle Testing," ENSCO, Inc., Springfield, VA, 1986.
5. Ross, H.E., Jr., "Update of Recommended Procedures for the Safety Performance Evaluation of Highway Appurtenances," National Cooperative Highway Research Program Project No. 22-7, Texas Transportation Institute, Texas A&M University, Proposed 1991.
6. "Vehicle Damage Scale for Traffic Accident Investigators," Traffic Accident Data Project Technical Bulletin No. 1, National Safety Council, Chicago, IL, 1971.
7. "Collision Deformation Classification, Recommended Practice J224 Mar 80," SAE Handbook Vol. 4, Society of Automotive Engineers, Warrendale, Penn., 1985.

8. APPENDICES

APPENDIX A.

ACCELEROMETER DATA ANALYSIS

	Page
A-1 Graph of Longitudinal Deceleration, Test I5-1	38
A-2 Graph of Longitudinal Deceleration, Test I5-1	39
A-3 Graph of Vehicle Change in Speed, Test I5-1	40
A-4 Graph of Vehicle Change in Speed, Test I5-1	41
A-5 Graph of Longitudinal Occupant Displacement, Test I5-1	42
A-6 Graph of Longitudinal Occupant Displacement, Test I5-1	43
A-7 Graph of Lateral Deceleration, Test I5-1	44
A-8 Graph of Lateral Deceleration, Test I5-1	45
A-9 Graph of Lateral Occupant Impact Velocity, Test I5-1	46
A-10 Graph of Lateral Occupant Impact Velocity, Test I5-1	47
A-11 Graph of Lateral Occupant Displacement, Test I5-1	48
A-12 Graph of Lateral Occupant Displacement, Test I5-1	49

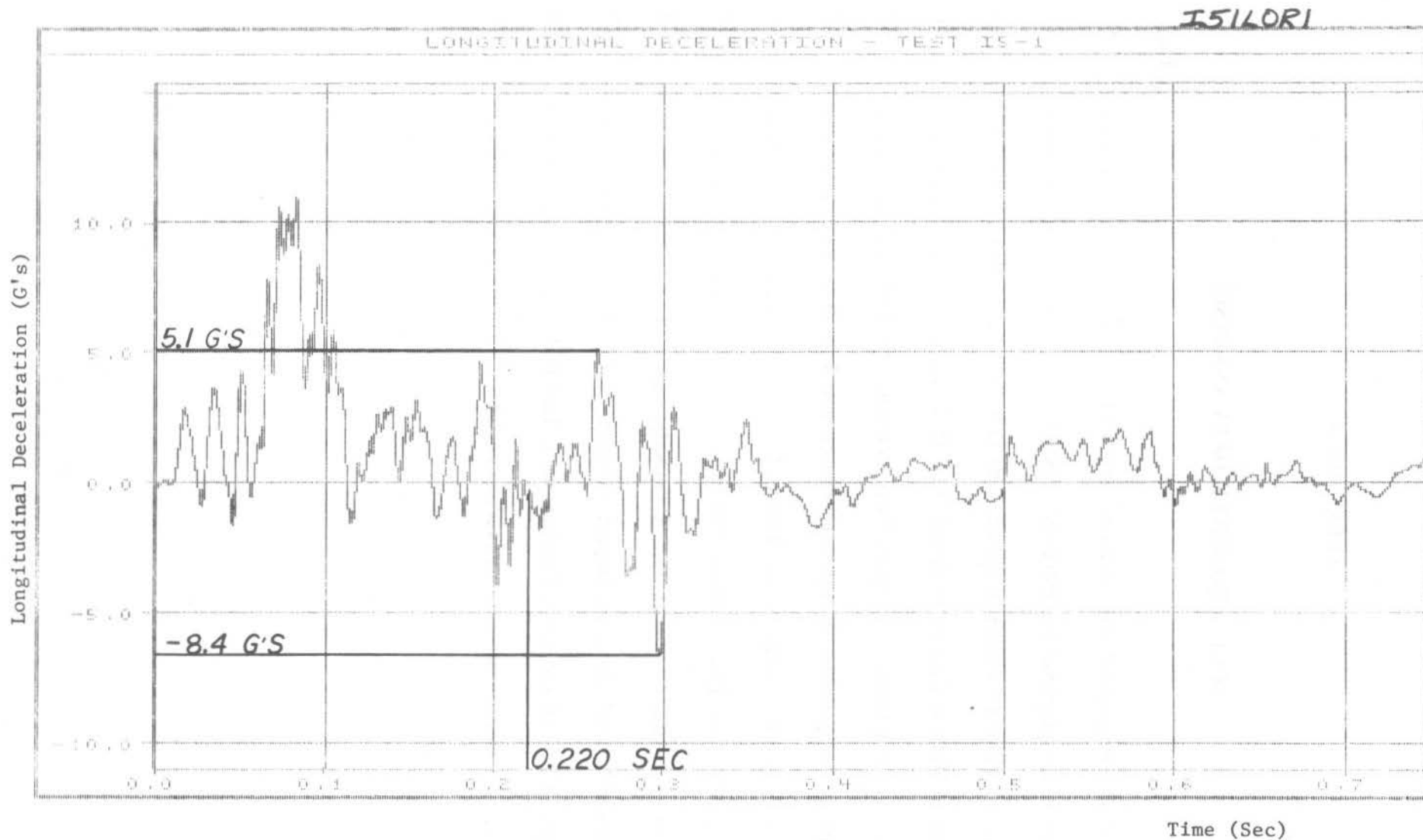

FIGURE A-1. GRAPH OF LONGITUDINAL DECELERATION, TEST I5-1.

I5160LZ

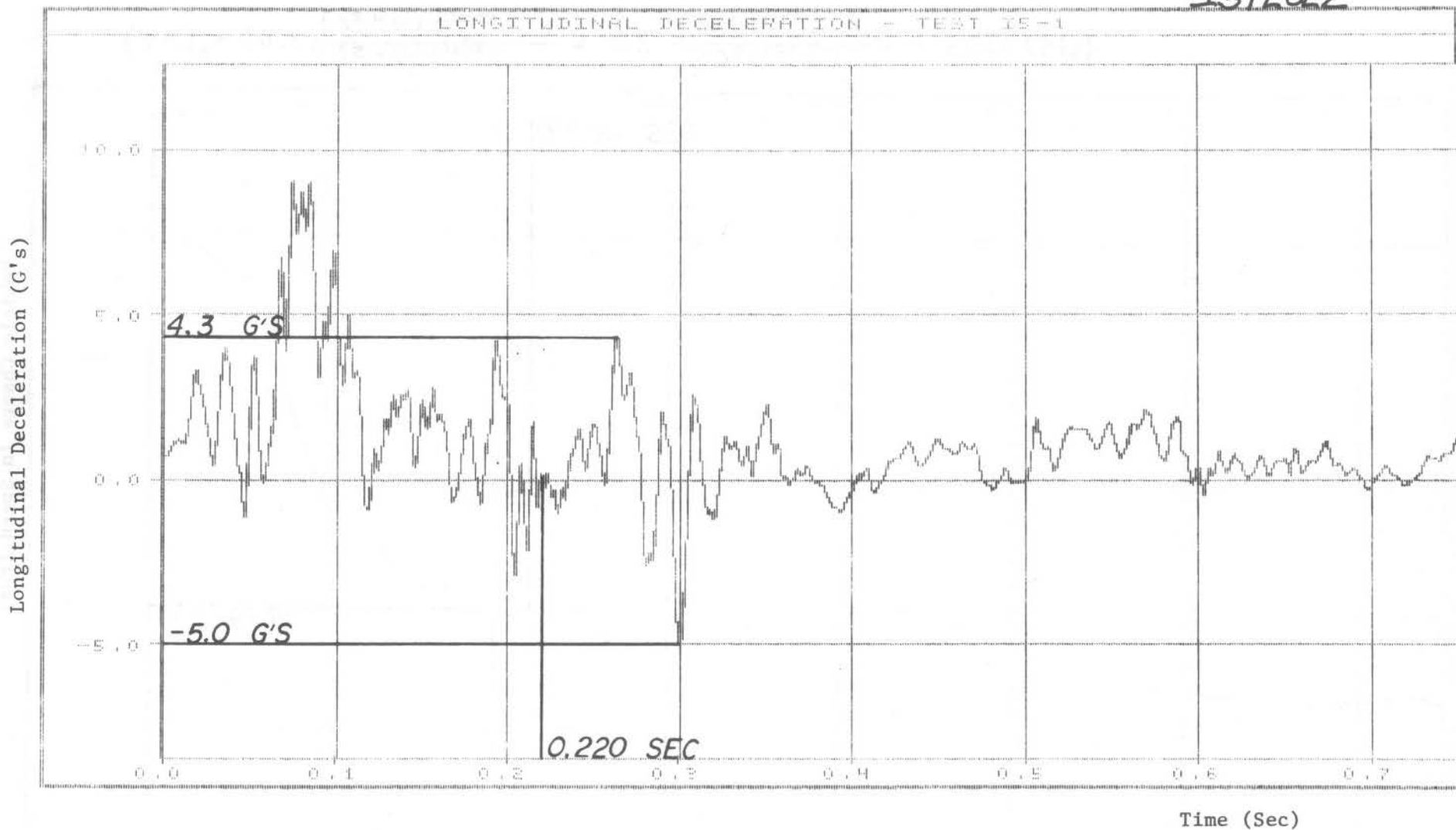
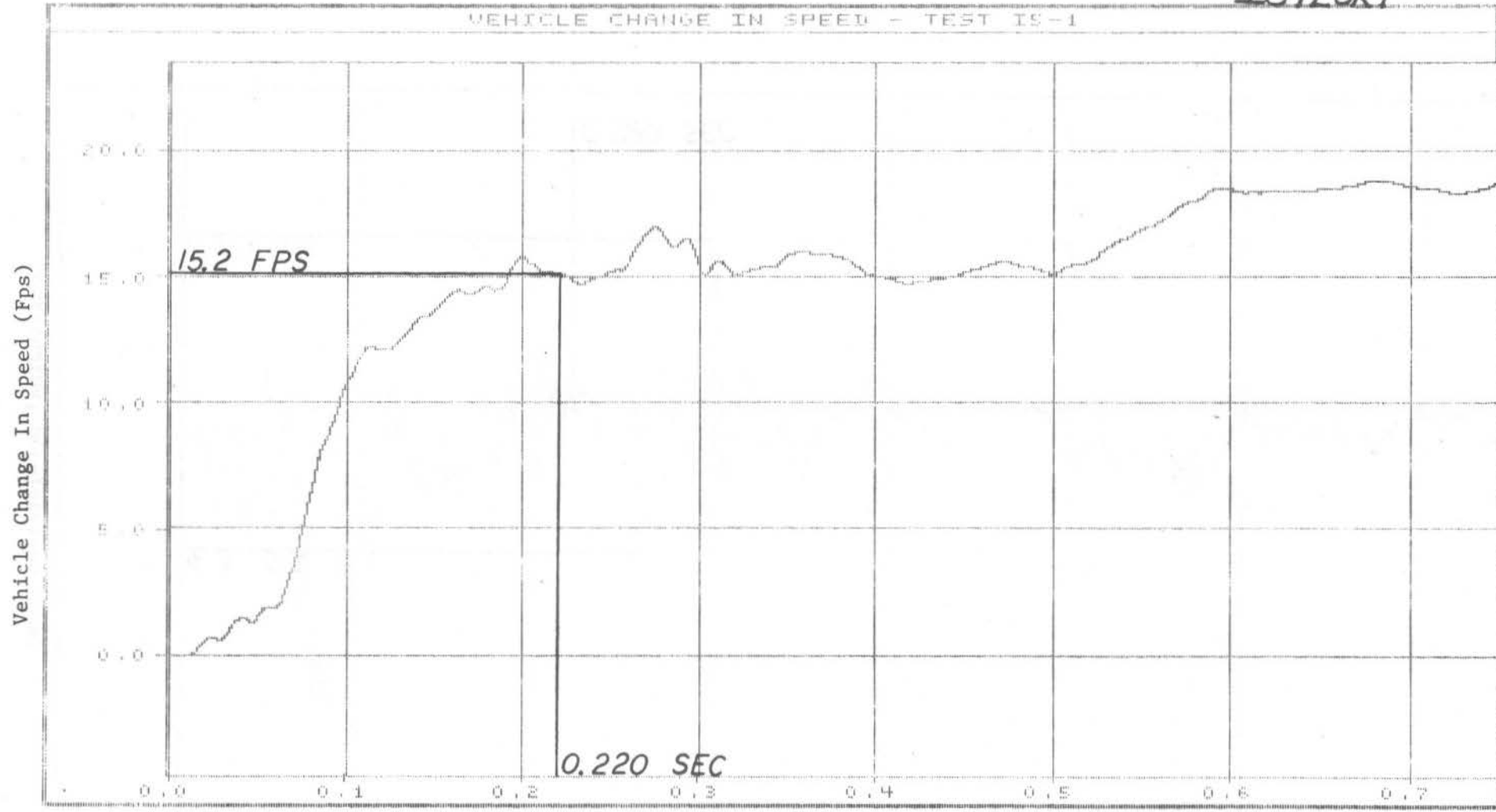

FIGURE A-2. GRAPH OF LONGITUDINAL DECELERATION, TEST I5-1.

I51LOR1



$$(\Delta V)^* = (\Delta V) \frac{(V \sin \theta)_{\text{Target}}}{(V \sin \theta)_{\text{Actual}}} = 15.2 \frac{(60 \sin 20^\circ)}{(60.6 \sin 22.5^\circ)} = 15.2(0.8849) = 13.45 \text{ fps}$$

FIGURE A-3. GRAPH OF VEHICLE CHANGE IN SPEED, TEST I5-1.

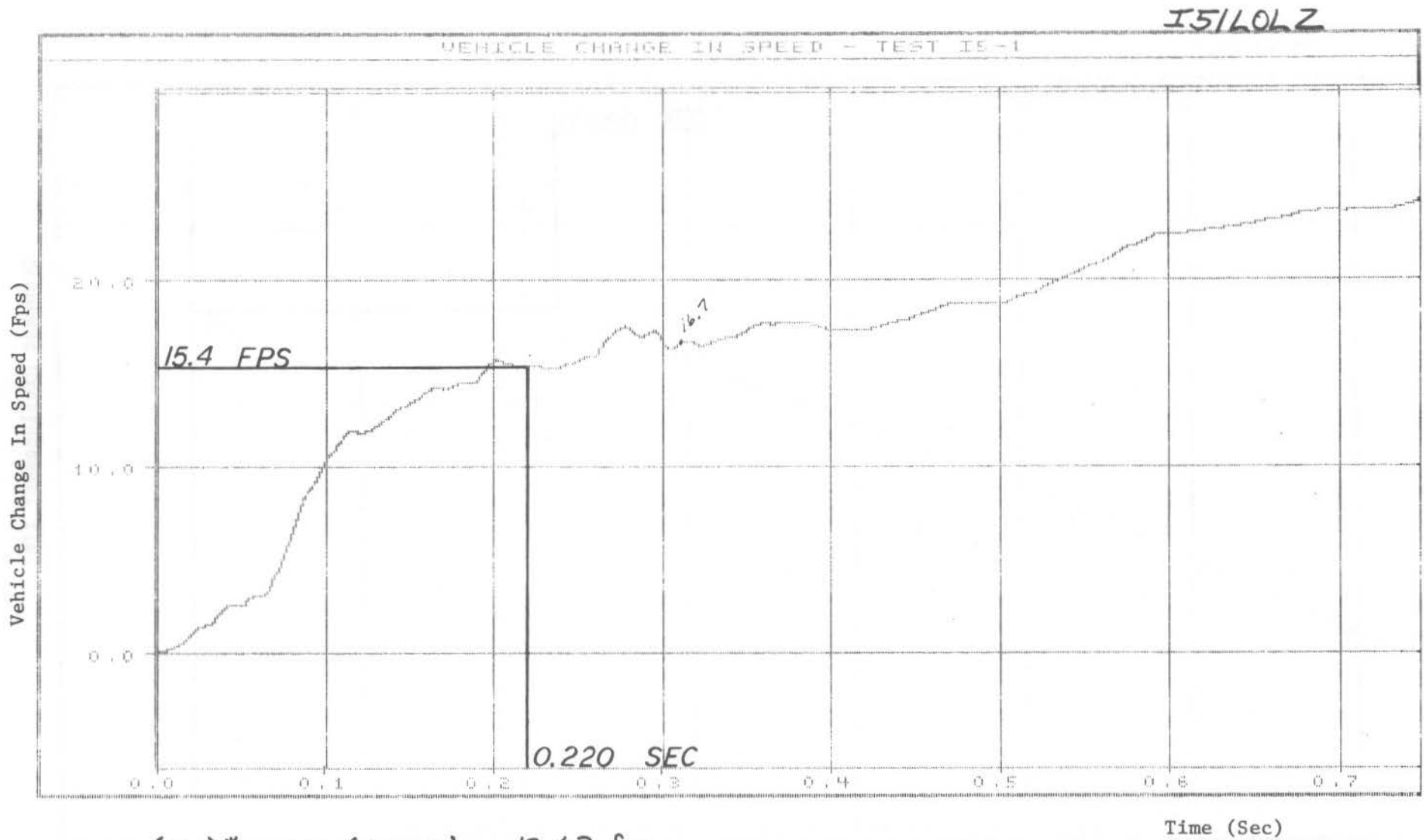

$$(\Delta V)^* = 15.4 (0.8849) = 13.63 \text{ fps}$$

FIGURE A-4. GRAPH OF VEHICLE CHANGE IN SPEED, TEST I5-1.

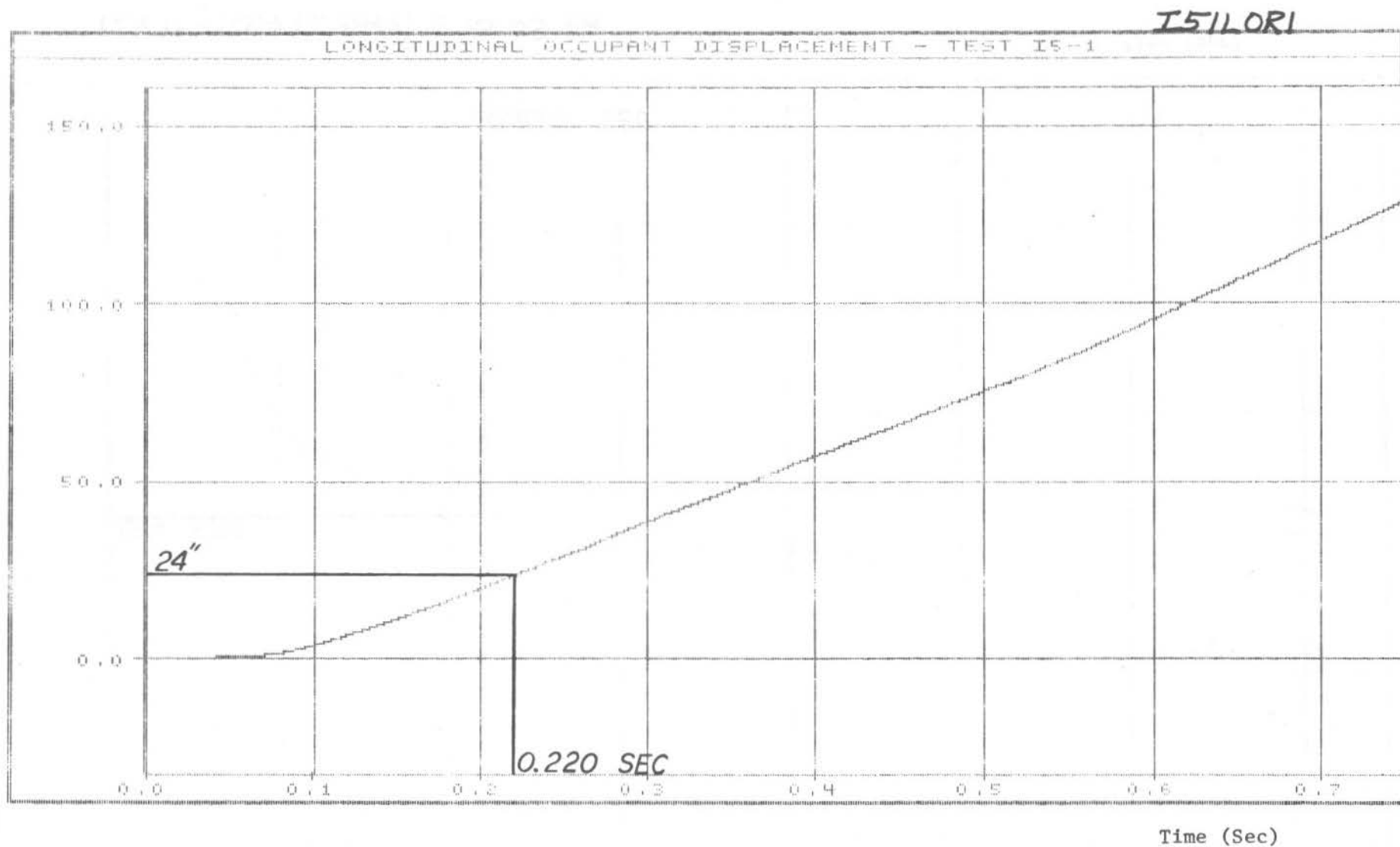
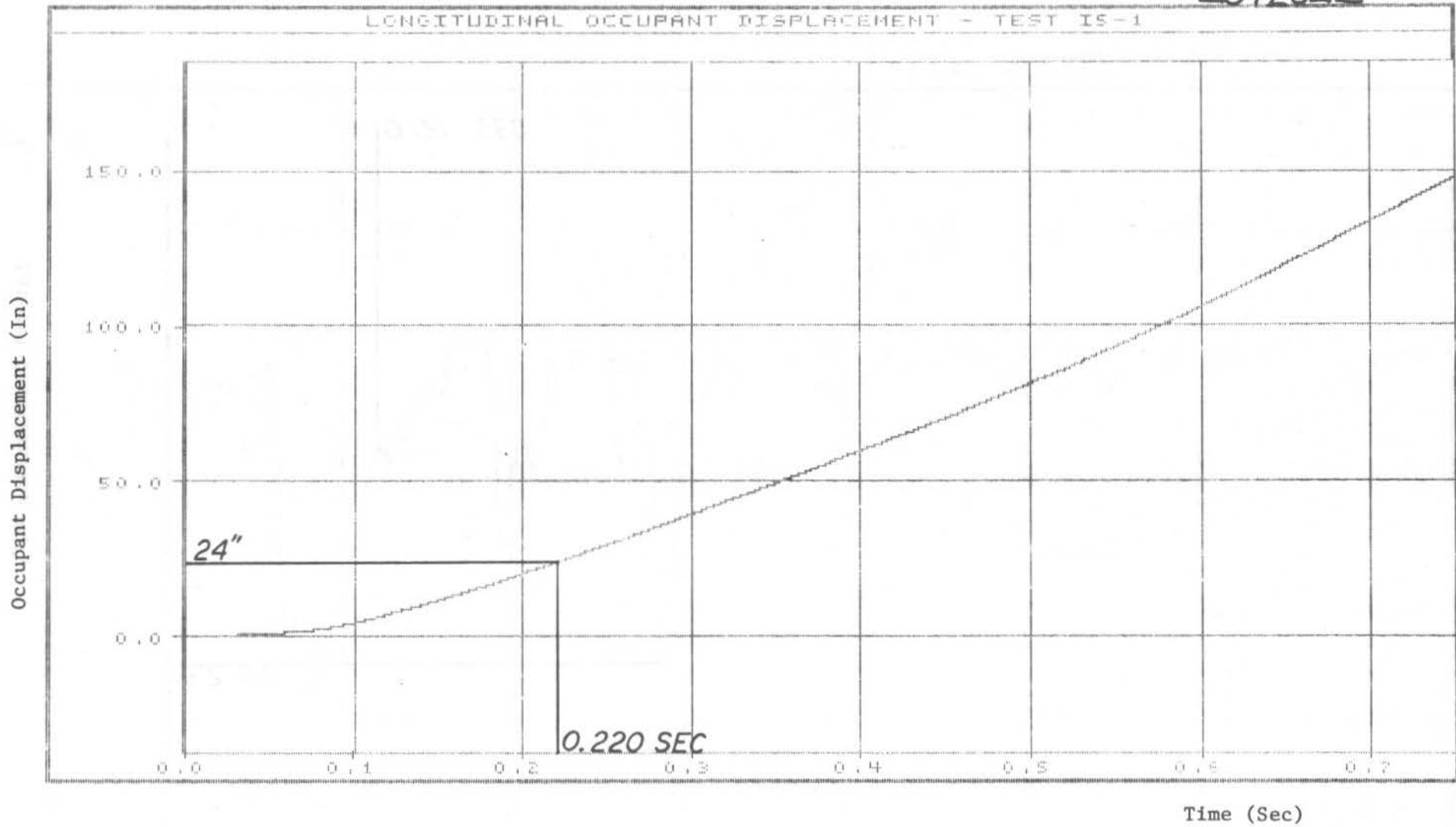

FIGURE A-5. GRAPH OF LONGITUDINAL OCCUPANT DISPLACEMENT, TEST I5-1.

I5110LZ



43

FIGURE A-6. GRAPH OF LONGITUDINAL OCCUPANT DISPLACEMENT, TEST I5-1.

I51LAR5

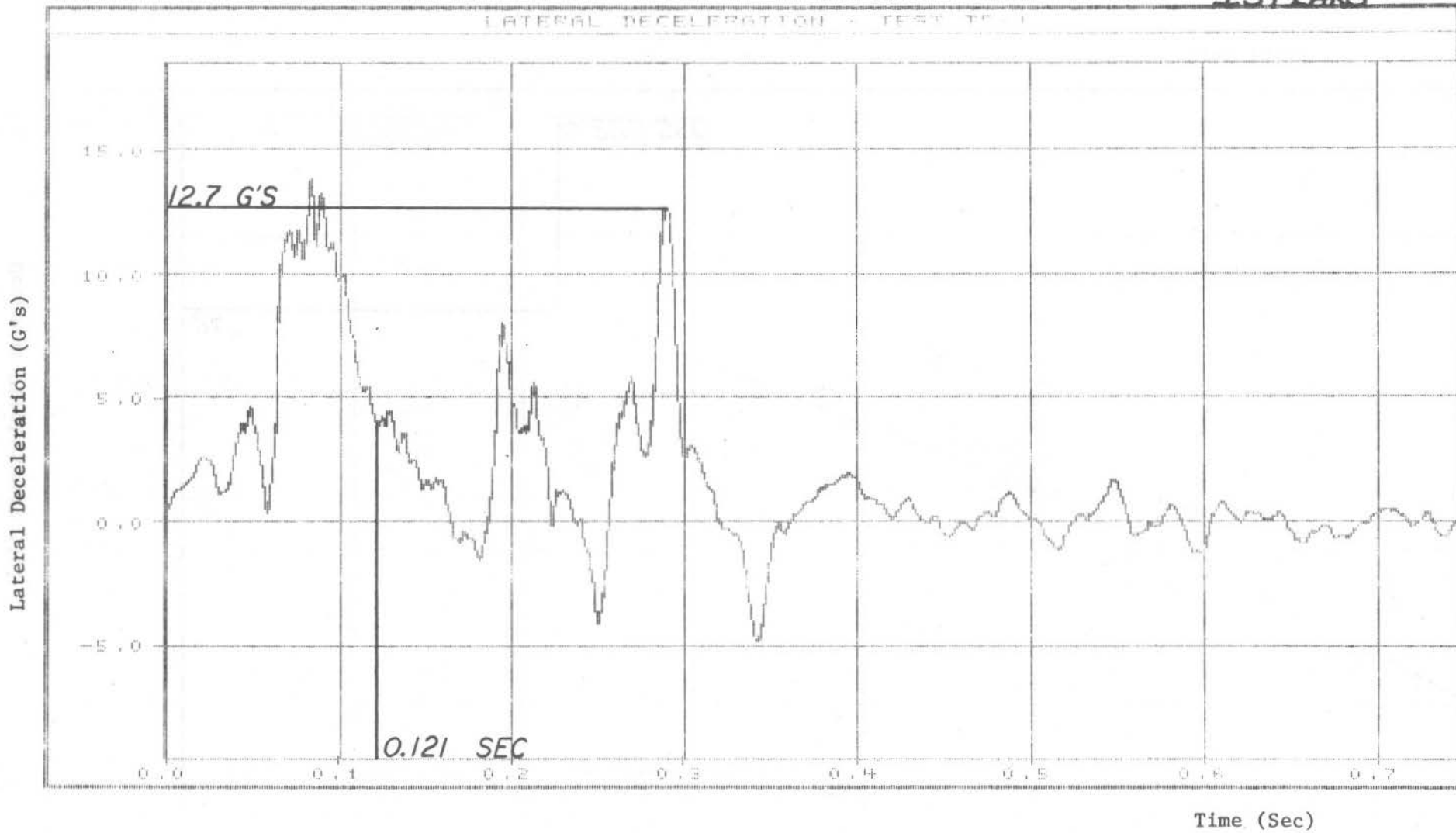

FIGURE A-7. GRAPH OF LATERAL DECELERATION, TEST I5-1.

I51LAL6

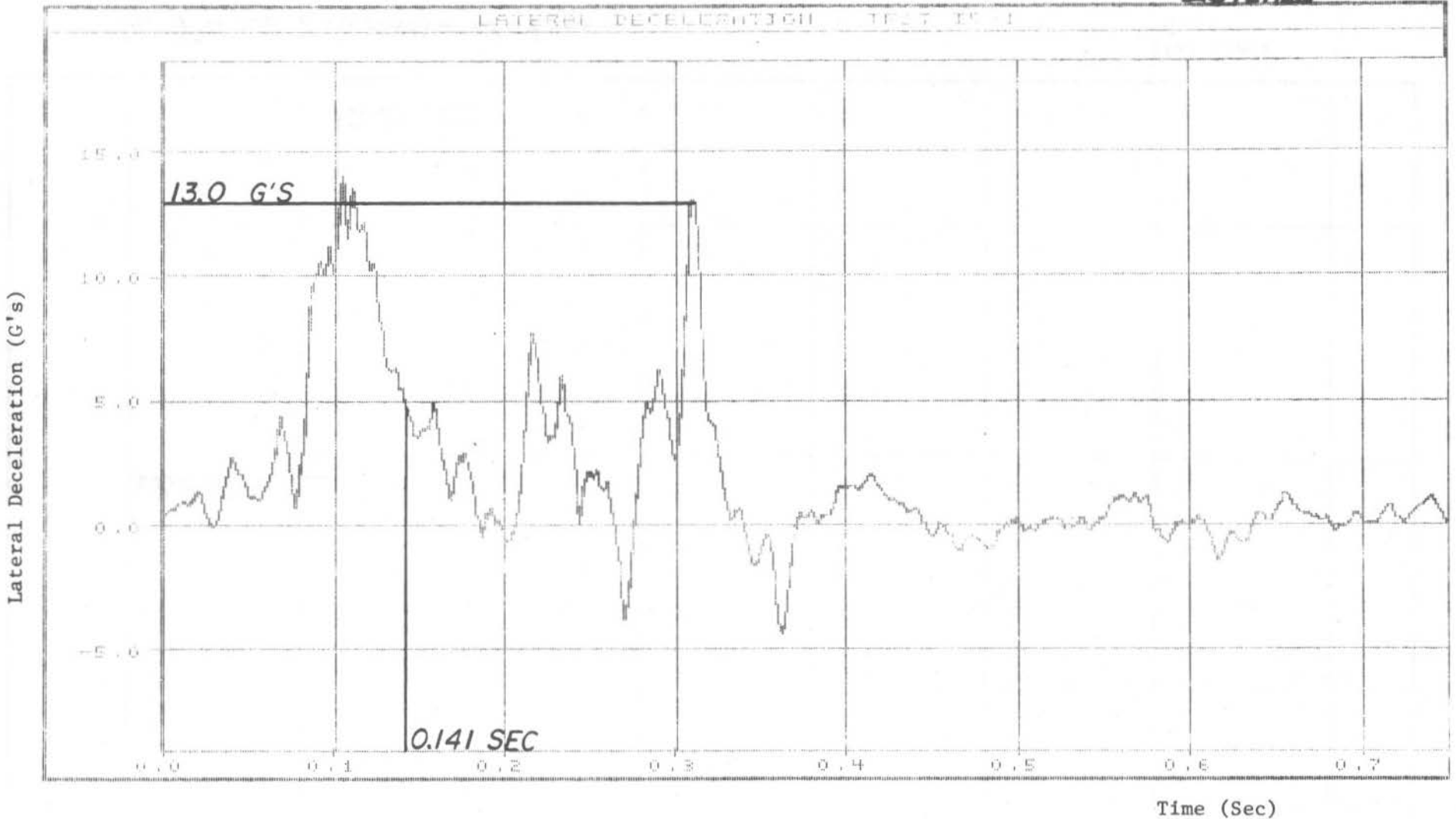

FIGURE A-8. GRAPH OF LATERAL DECELERATION, TEST 15-1.

I51LAR5

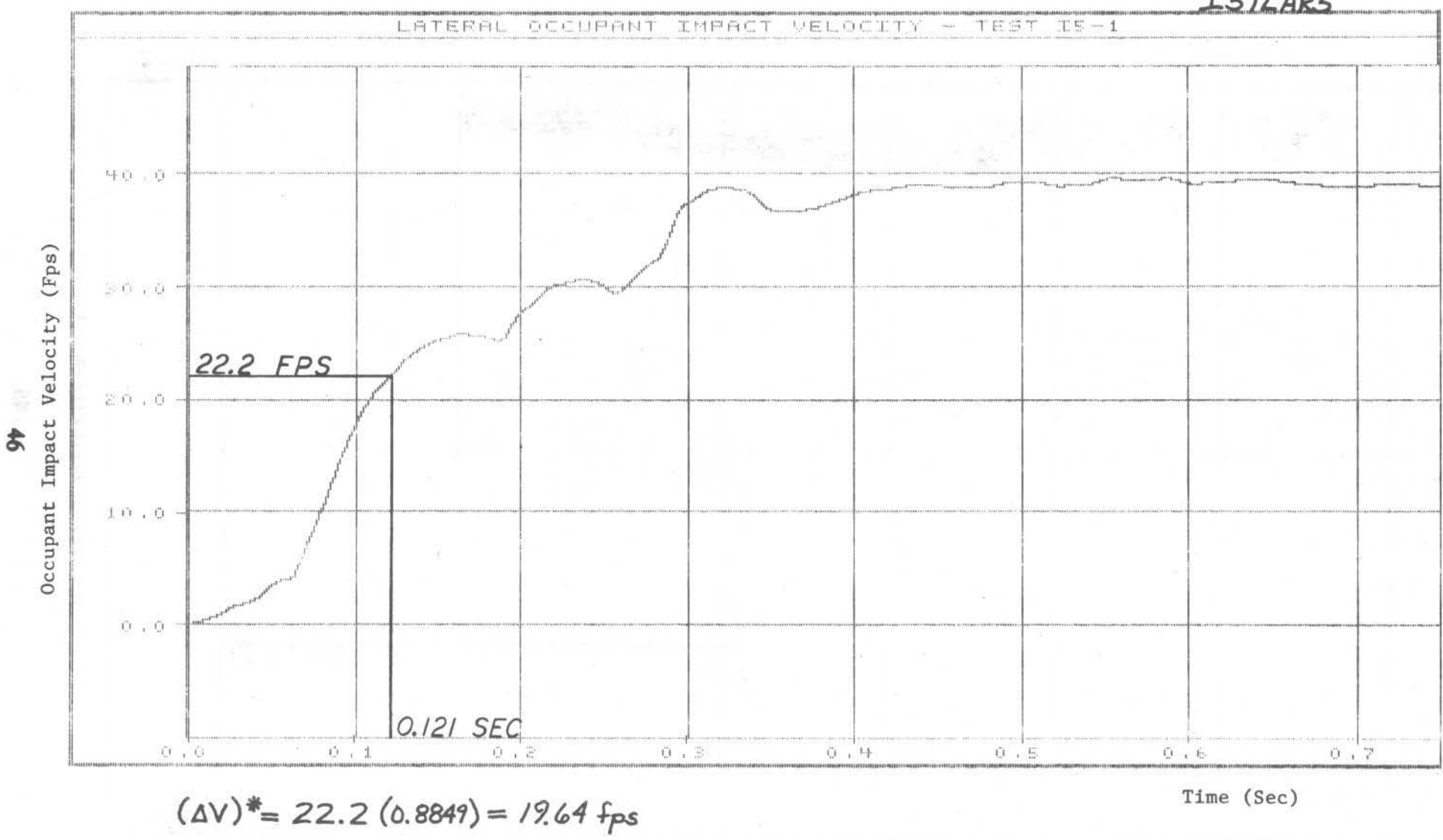

FIGURE A-9. GRAPH OF LATERAL OCCUPANT IMPACT VELOCITY, TEST I5-1.

I51LAL6

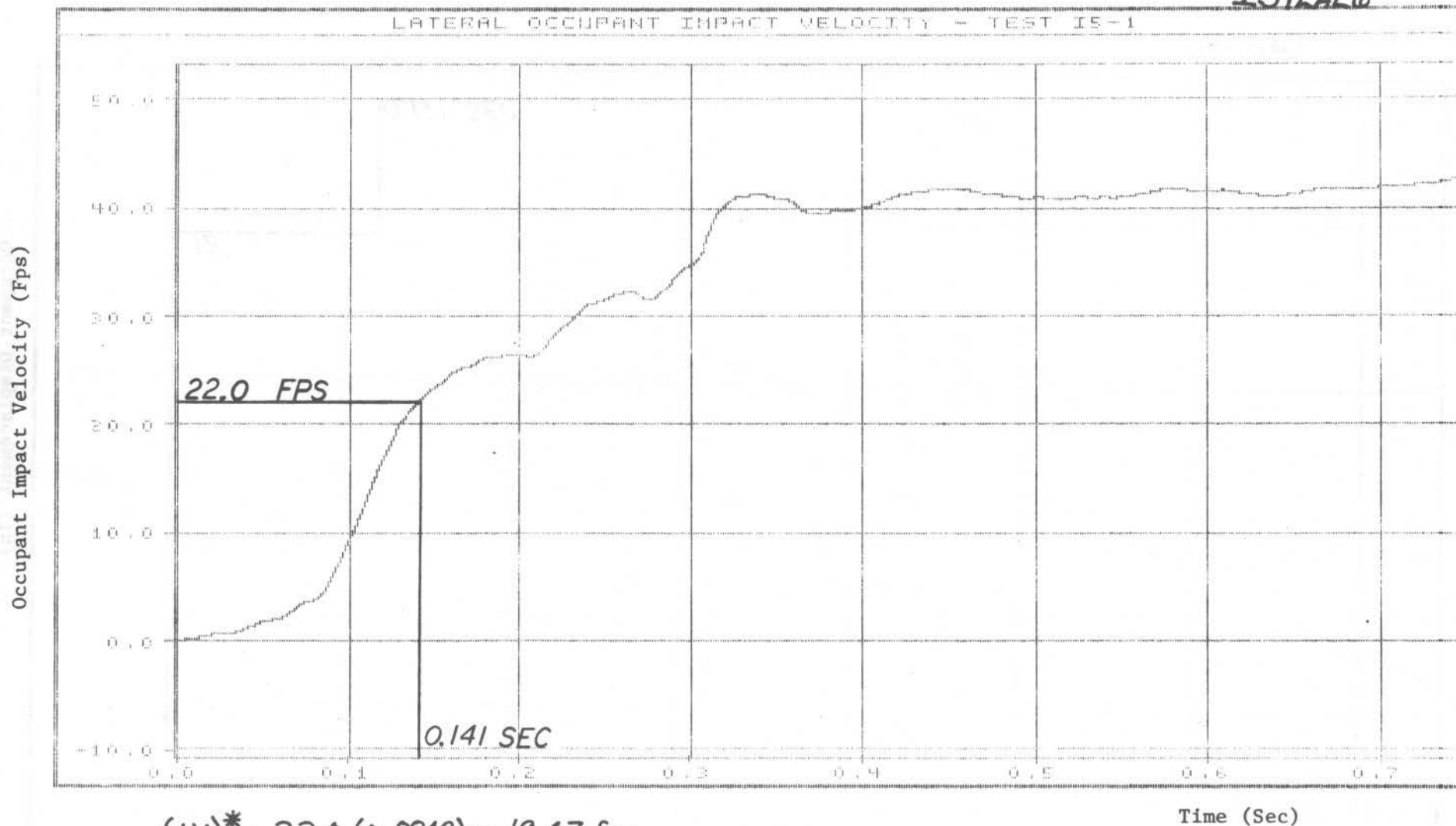

FIGURE A-10. GRAPH OF LATERAL OCCUPANT IMPACT VELOCITY, TEST I5-1.

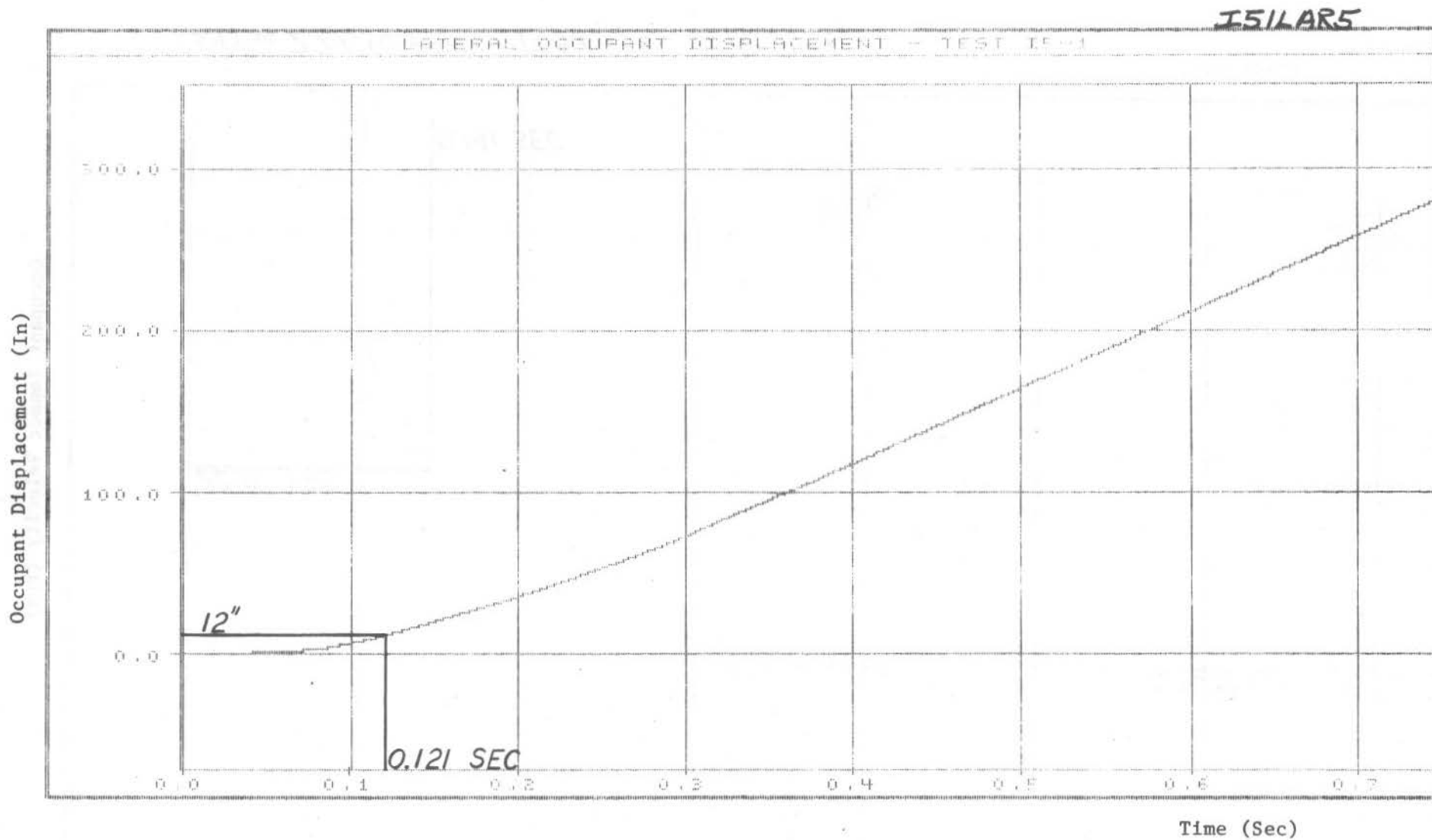

FIGURE A-11. GRAPH OF LATERAL OCCUPANT DISPLACEMENT, TEST I5-1.

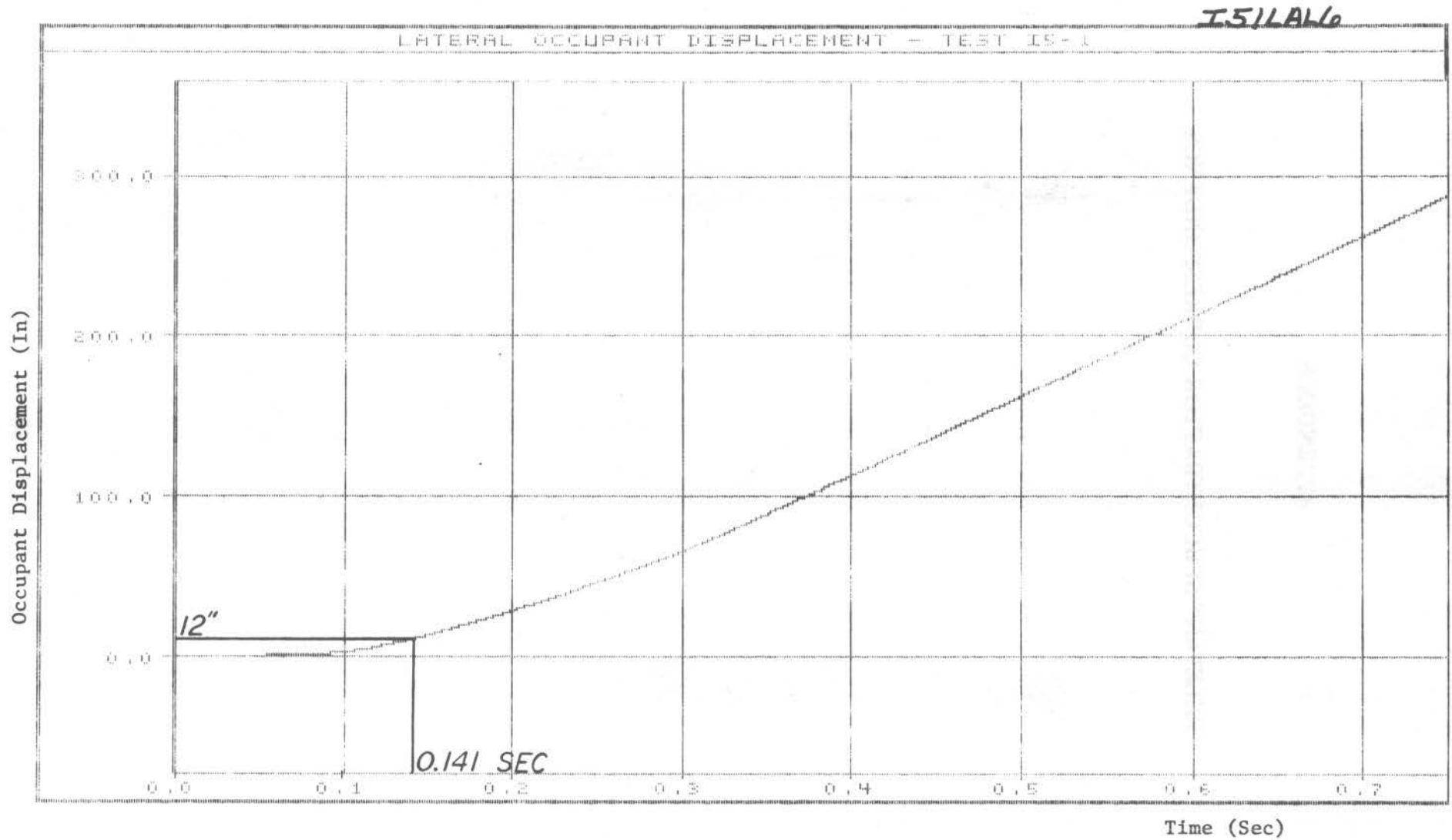

FIGURE A-12. GRAPH OF LATERAL OCCUPANT DISPLACEMENT, TEST I5-1.

APPENDIX B.

RELEVANT SUBCONTRACTOR CORRESPONDENCE

M. E. Collins Contracting Co., Inc.
P.O. Box 83
Wahoo, NE 68066

(402) 443-3663
Dec. 18, 1989

To: Dr. Ed Post
Civil Engr. Dept.
Univ. of Nebraska
W 348 Nebraska Hall
Lincoln, NE 68588-0531

Re: Steel Temporary Barrier Rail
Crash Test for Iowa D.O.T.

Dear Dr. Post,

As per your request, I have addressed in this letter the difficulties which M. E. Collins Contracting Co., Inc. encountered while dismantling the railing on the above mentioned project.

Dismantling of the rail began at the joint at which impact occurred. The bolts were initially attempted to be removed by the use of a breaker bar and socket. This proved to be unsuccessful. A one inch air impact drill was then used and it did remove all of the bolts except for one. The bolts which the air impact drill did remove, damaged the threads beyond reuse. The remaining bolt required the use of a torch to cut off the bolt head.

The remainder of the steel rail was dismantled at every other joint. The one inch air impact drill was used on all of these bolts with four or five bolts requiring the use of a torch. The majority of the bolts removed were not reusable because of damage to the threads.

In my opinion, the work required to assemble and disassemble this rail system does not lend itself well to a multiple use barrier rail system. Mobilizing and setting the rails in place was not difficult, but assembling the rail was very time consuming even though the holes in the plates and rails were match drilled. The force required to remove the bolts also stripped the majority of the bolts. I also believe that any attempt to assemble this rail system on an unlevel surface would be very difficult.

I hope that this letter has answered your questions adequately, and if I can be of any further help please let me know.

Respectfully,

Steve A. Buchanan