

PAPER • OPEN ACCESS

Review of the ELI-NP-GBS low level rf and synchronization systems

To cite this article: L Piersanti *et al* 2018 *J. Phys.: Conf. Ser.* **1067** 072031

View the [article online](#) for updates and enhancements.



IOP | ebooks™

Bringing you innovative digital publishing with leading voices to create your essential collection of books in STEM research.

Start exploring the collection - download the first chapter of every title for free.

Review of the ELI-NP-GBS low level rf and synchronization systems

L Piersanti¹, D Alesini¹, M Bellaveglia¹, F Cardelli¹, M Diomedea^{1,2},
A Gallo¹, V Martinelli¹, B Baricevic³, R Cerne³, G Jug³ and P N
Dominguez⁴

¹ Istituto Nazionale di Fisica Nucleare, Laboratori Nazionali di Frascati (INFN-LNF), Via Enrico Fermi 40, 00044 Frascati, Italy

² “Sapienza” University of Rome, P.le Aldo Moro 5, 00185 Rome, Italy

³ Instrumentation Technologies, Velika pot 22, 5250 Solkan, Slovenia

⁴ Menlo Systems, Am Klopferspitz 19A, 82152 Planegg, Germany

E-mail: luca.piersanti@lnf.infn.it

Abstract. The Gamma Beam System (GBS) of ELI-NP is a linac based gamma-source in construction at Magurele (RO) by the European consortium EuroGammaS led by INFN. Photons with tunable energy and with intensity and brilliance well beyond the state of the art will be produced by Compton back-scattering between a high quality electron beam (up to 740 MeV) and a 515 nm intense laser pulse. Production of very intense photon flux with narrow bandwidth requires multi-bunch operation at 100 Hz repetition rate. A total of 13 klystrons, 3 S-band (2856 MHz) and 10 C-band (5712 MHz) will power a total of 14 Travelling Wave accelerating sections (2 S-band and 12 C-band) plus 3 S-band Standing Wave cavities (a 1.6 cell RF gun and 2 RF deflectors). Each klystron is individually driven by a temperature stabilized LLRF module, for a maximum flexibility in terms of accelerating gradient, arbitrary pulse shaping (e.g. to compensate beam loading effects in multi-bunch regime) and compensation of long-term thermal drifts. In this paper, the whole LLRF system architecture and bench test results, the RF reference generation and distribution together with an overview of the synchronization system will be described.

1. Introduction

An advanced source of gamma-ray photons will be built in Magurele (Bucharest) in the framework of the ELI-NP-GBS project [1, 2] by the EuroGammaS consortium led by INFN. The gamma-rays will be generated by a high quality electron beam colliding with a high power laser (200 mJ, 3.5 ps, 515 nm). The machine is expected to produce photons with tunable energy between 0.2 and 19.5 MeV with a narrow bandwidth ($< 0.5\%$) and a high spectral density ($0.8 - 4 \times 10^4$ ph/s eV) [3].

The accelerator layout is based on a C-band (5712 MHz) RF linac, with a S-band photo-injector similar to that of SPARC-LAB at LNF-INFN (Frascati, Italy) [4], able to deliver a high phase space density electron beam in the 300-740 MeV energy range. The repetition rate has been chosen to be 100 Hz and, in order to fulfil the tight requirements on photon fluxes, the machine is foreseen to work in multi-bunch mode (fitting 32 electron bunches in each RF pulse). The main electron beam parameters of the ELI-NP-GBS, together with the description of the



complete RF system have been reported in [2, 5]. In the next sections the LLRF architecture and the synchronization system will be described.

2. Linac overview

ELI-NP-GBS photo-injector comprises a 1.6 cell S-band RF-gun, which has been manufactured with a new fabrication technique without copper brazing [6, 7, 8, 9], and two S-band 3 m long SLAC-type TW constant gradient accelerating structures. The S-band system comprises also two deflecting cavities used for longitudinal beam diagnostics. The linac booster is made of 12 TW C-band disk loaded accelerating structures. Each section is 1.8 m long, quasi-constant gradient with a $2\pi/3$ field phase advance per cell and will operate at an average accelerating gradient of 33 MV/m. Moreover, to avoid beam break up instabilities, the structures have been designed including a waveguide HOM damping system with 4 SiC RF absorbers for each cell [10, 11, 12, 13].

Furthermore, in order to reduce bunch-by-bunch energy spread due to structure beam loading (BL), a tailored pulse shaping compensation has to be provided to the klystrons by the LLRF systems [5]. Moreover, to deliver the flexibility required to compensate bunch-to-bunch energy spread, each accelerating section is individually driven by a dedicated power station (with the exception of the last 4 TW sections that are fed by 2 klystrons).

3. Low level RF system

The aim of any LLRF system is threefold: it has to generate and properly shape the RF pulses used to drive the power units, it has to acquire, monitor and control the RF signals picked-up along the accelerator and it has to provide a stable reference distribution along the facility. The LLRF system for the ELI-NP-GBS project (Libera LLRF) has been manufactured by Instrumentation Technologies (SI) [14] and consists of 13 temperature stabilized RF front ends (one for each power unit): 3 S-band and 10 C-band. This choice has been made in order to guarantee the maximum flexibility in terms of pulse shaping and machine operation stability. One of the main features of Libera LLRF platform is, in fact, the possibility to perform a pulse-by-pulse feedback. Moreover, the pulse shape can be arbitrarily set (e.g. for BL compensation) simply loading a spreadsheet mask to Libera FPGA. The request for thermal stabilization has been introduced to compensate the long-term effect of temperature drifts, that must not exceed 100 fs for normal operation: $(24 \pm 2)^\circ\text{C}$. Overall Libera LLRF modules have to guarantee an amplitude resolution of 0.1 % RMS and a phase added jitter lower than 10 fs. Each board contains four main elements: (i) the analog front-end with 8 RF inputs per module, (ii) the analog back-end (with 1 RF vector modulator output), (iii) the main CPU (which hosts the sampling cards, the FPGA and the EPICS control system server), and (iv) the LO generator and timing unit (with 1 input for the RF reference, 1 input for the trigger of FPGA, DAC and ADC and the interlock I/O). The main parameters of Libera LLRF boards have been summarized in Table 1.

Some preliminary measurements have been carried out at INFN-LNF on one C-band LLRF board to assess its amplitude and phase resolution (in a room without thermal conditioning) and to quantify the ability to reject slow sinusoidal disturbances added in the feedback chain. Fig. 1 and 2 summarize the amplitude and phase out-of-loop resolution measurements. After two hours of continuous data acquisition (more than 70000 shots) a standard deviation of 0.019 % and 0.013 deg (corresponding to < 8 fs at 5712 MHz) have been obtained for amplitude and phase respectively. Both values result well within specifications.

Amplitude and phase loop capabilities have been tested also when a slow sinusoidal disturbance (ranging from 0.1 to 2 Hz with constant amplitude) has been added in the feedback path. Two sets of measurements have been performed, where the integral gain of the loop has been varied by a factor of 10. As shown in Fig. 3, the loop behaves as expected, and the cut-off

frequency evaluated from a fit to the analytical closed loop transfer function gives 0.7 Hz and 6.8 Hz for the two values of the gain.

Table 1. Libera LLRF main specifications

Sub-system	Parameter	Spec. Value
	Amp. resolution	0.1 %
	Phase added jitter	<10 fs
	Long term stability*	100 fs
Analog front-end	BW	5 MHz
	Max RF level	20 dBm
Analog back-end	BW	16 MHz
	Max RF level	13 dBm
LO generation and timing	Min RF ref. level	15 dBm
	Sampl. clock (16 bit)	119 MHz
	IF freq.	44.625 MHz

* at $T = (24 \pm 2) ^\circ\text{C}$

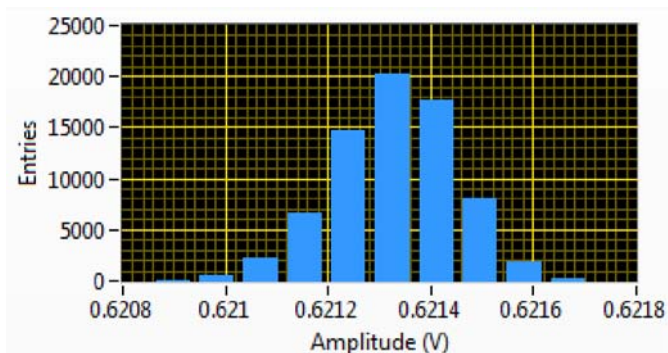

Figure 1. Out-of-loop measurement of amplitude feedback resolution over 70 000 shots (std dev. 0.019 %).

4. Synchronization system

The general ELI-NP-GBS synchronization requirement is that the relative arrival time jitter at the interaction point (IP) of electron bunches and photon pulses has to be lower than 500 fs rms. For this reason, the synchronization system task is to provide to all clients (two interaction laser systems, two RF extractors at 2856 MHz and 5712 MHz, used as reference for power units and LLRF) an ultra-stable reference with a relative jitter < 70 fs.

Given the remarkable link lengths, the reference will be distributed to the various clients in the optical domain, in order to exploit: the fiber-link THz bandwidth, its immunity to electromagnetic interference, the very low attenuation over hundreds of meters and the large sensitivity obtainable by optical based timing detection.

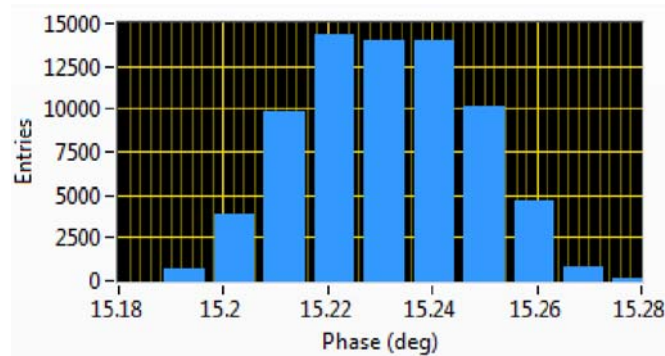

Figure 2. Out-of-loop measurement of phase feedback resolution over 70 000 shots (std dev. < 8 fs at 5712 MHz).

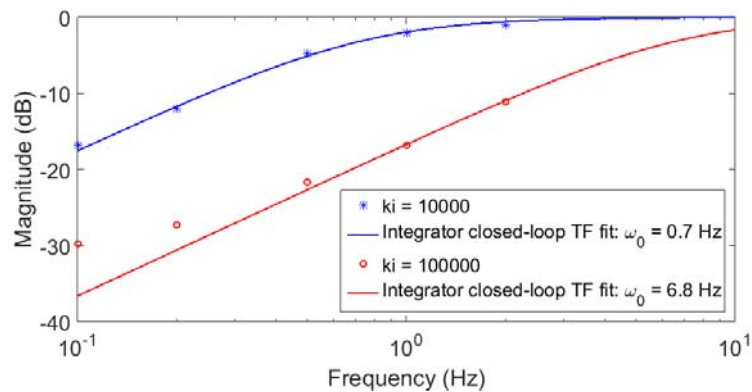

Figure 3. Integral gain feedback closed loop transfer function measured (dots) compared to the analytical form (solid line). Each point has been evaluated on acquisitions of 1000 shots.

The ELI-NP-GBS synchronization system has been manufactured by Menlo Systems (DE) [15] and its layout is sketched in Fig. 4, while its main parameters are listed in Table 2. It consists of two main parts: (i) reference generation and distribution, (ii) client synchronization. In the following paragraphs both systems will be briefly described.

Table 2. ELI-NP-GBS timing distribution system parameters

Parameter	Spec. Value
Pulse width at link end	< 200 fs
Fiber laser wavelength	1560 nm
Free space wavelength (SHG output)	780 nm
Pulse rep. rate (RF/46)	62.08 MHz
Integrated timing jitter (1 kHz-10 MHz)	< 5 fs
Amplitude stability (rms)	< 0.1 %
Phase jitter rel. to ref. (rms 0.1 Hz-1 kHz)	< 10 fs

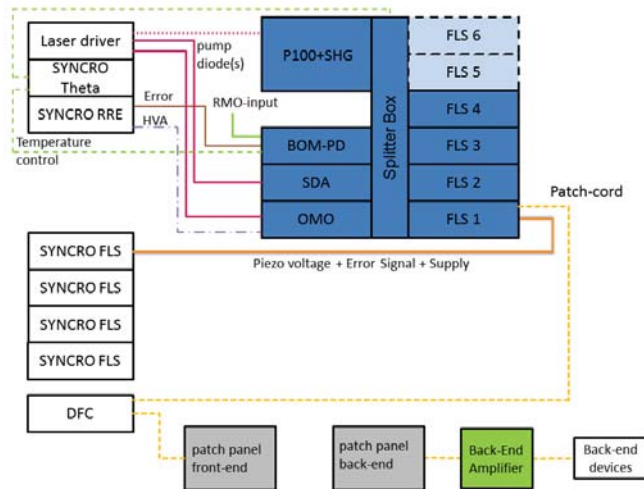

Figure 4. ELI-NP-GBS synchronization system layout.

4.1. Reference Generation and Distribution

The reference signal is generated by a Reference Master Oscillator (RMO) which is a μ -wave crystal oscillator (MO-2856-V3 produced by Laurin A.G.) with ultra-low phase noise characteristics (10 Hz-10 MHz measured absolute jitter < 60 fs). The role of this device is to provide a reliable reference tone to Menlo Optical Master Oscillator (OMO), which is an Erbium-doped mode-locked low noise laser oscillator, that encodes the reference timing information in the repetition rate of short optical pulses in the IR spectrum (1560 nm). The RMO guarantees the long term stability of the OMO, and imprints its low-frequency noise figure to the whole facility timing line, within the locking bandwidth.

The repetition rate of the OMO is locked to the RMO using a piezo stack as the actuator and the Menlo Systems SYNCRO-RRE (Repetition Rate stabilization Electronics) as the loop filter. The SYNCRO is a universal locking platform which can be configured for various applications. In our case, the SYNCRO-RRE provides feedback to both the piezo actuator, cancelling fast fluctuations, and to a high resolution motorized stage, which is used to counteract the larger, but slower, temperature-induced drifts. The PLL is completed by a Balanced Optical-Microwave Phase Detector (BOM-PD) that is based on a Sagnac interferometer [16], which, in first order approximation, is insensitive to amplitude and temperature variations (overcoming many problems associated with a direct photo-detection scheme).

Once the laser pulses are generated, they are amplified by an Erbium doped fiber amplifier (SDA) and distributed through a splitter-box to all the clients. One of the channels of the splitter-box is further amplified (P100 module) and converted by a second harmonic generator (SHG) to a 780 nm free space output, used as direct seed for the photocathode laser, which results “naturally synchronous” with the OMO.

4.2. Client Synchronization

Four main clients have been designated in the ELI-NP-GBS machine: two interaction lasers and two RF extractors (one at 2856 MHz and one at 5712 MHz) that provide the RF reference to the LLRF and thus at the power units. Depending on the nature of the clients, the PLL can be either “fully optical” (e.g. for the two interaction lasers) employing two optical cross-correlators, or “electro-optical” (e.g. for the two RF extractors) locking a BOM-PD to a VCO. In the latter case, once the RF reference has been extracted from the laser pulses, it must be distributed to various sub-systems such as: LLRF modules, machine diagnostics (e.g. cavity BPMs electronics) alignment lasers and so on. For this reason, three boards (one for each RF

frequency: 62.08 MHz, 2856 MHz and 5712 MHz) have been designed and realized by INFN-LNF RF group to amplify and route the coaxial reference signals throughout the facility.

The clients will be reached by means of four dispersion compensated fiber links with active length stabilization, in order to deliver short (< 200 fs) synchronous pulses to the end users. The time of propagation in the fiber is, in fact, affected by temperature drift and acoustic noise. The stabilization is achieved sending back a pulse from the link-end, by means of a Faraday rotating mirror, and comparing with an optical cross-correlator the retro-reflected pulse with a reference pulse from the oscillator. The pulse propagation length is kept constant by moving a piezo inside the Fiber Link Stabilization unit (FLS), which is driven by the cross-correlator error signal (also inside the FLS). The typical performance of the link length stabilization system, reported in Fig. 5, has been assessed at Menlo Systems headquarters, showing an out-of-loop residual link drift of ≈ 6.4 fs rms over 11 h of continuous measurement on a 200 m long link.

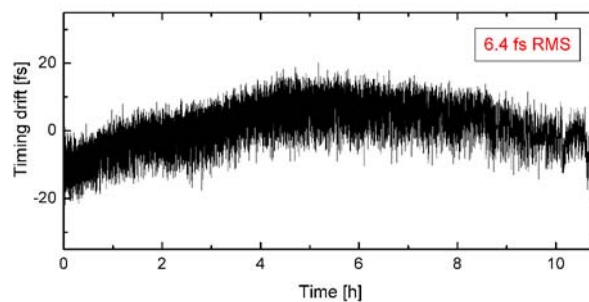

Figure 5. Results of 200 m link stabilization over 11 hours, picture courtesy of Menlo Systems.

Conclusions

In this paper the main features of the LLRF and synchronization system for the ELI-NP-GBS project have been presented together with some bench test results for the LLRF resolution (0.019% and < 8 fs at 5712 MHz for amplitude and phase respectively) and disturbance rejection. Both systems are well within specifications and will be commissioned in Magurele in the next future.

References

- [1] Adriani O *et al.* 2014 Technical Design Report EuroGammaS proposal for the ELI-NP gamma beam system *arXiv:1407.3669*.
- [2] Giribono A *et al.* 2017 ELI-NP GBS status *Proc. 8th Int. Part. Accel. Conf. (Copenhagen)* pp 880–883
- [3] Vaccarezza C *et al.* 2016 Optimization studies for the beam dynamics in the rf linac of the ELI-NP gamma beam system *Proc. Int. Part. Accel. Conf. (Busan)* pp 1850–1853
- [4] Ferrario M *et al.* 2010 Experimental demonstration of emittance compensation with velocity bunching *Phys. Rev. Lett.* **104** 054801
- [5] Piersanti L *et al.* 2016 The rf system of the ELI-NP gamma beam source *Proc. Int. Part. Accel. Conf. (Busan)* pp. 407–410
- [6] Alesini D *et al.* 2015 New technology based on clamping for high gradient radio frequency photogun *Phys. Rev. ST Accel. Beams* **18** 092001
- [7] Alesini D *et al.* 2016 Process for manufacturing a vacuum and radio-frequency metal gasket and structure incorporating it *International patent application PCT/IB2016/051464*

- [8] Cardelli F *et al.* 2016 Design of linac with the new gasket-clamping fabrication technique *Proc. Int. Part. Accel. Conf. (Busan)* pp 403–406
- [9] Alesini D *et al.* 2017 High power test results of the ELI-NP S-band gun fabricated with the new clamping technology without brazing *Proc. Int. Part. Accel. Conf. (Copenhagen)* pp 3662–3665
- [10] Alesini D *et al.* 2013 The damped C-band rf structures for the European ELI-NP proposal *Proc. Int. Part. Accel. Conf. (Shanghai)* pp 2726–2728
- [11] Alesini D *et al.* 2014 Design and rf test of damped C-band accelerating structures for the ELI-NP linac *Proc. Int. Part. Accel. Conf. (Dresden)* pp 3856–3859
- [12] Alesini D *et al.* 2017 Realization and high power tests of damped C-band accelerating structures for the ELI-NP linac *Proc. Int. Part. Accel. Conf. (Busan)* pp 399–402
- [13] Alesini D *et al.* 2017 Design of high gradient, high repetition rate damped C-band rf structures *Phys. Rev. Accel. Beams* **20** 032004
- [14] Instrumentation Technologies <http://www.i-tech.si>
- [15] Menlo Systems <http://www.menlosystems.com>
- [16] Kim J *et al.* 2007 Long-term stable microwave signal extraction from mode-locked lasers *Opt. Express* **15** 8951–9