

Eskom-ZESA interconnected power system modelling

Nkosinomusa S. Gumede

**A research report submitted to the Faculty of Engineering and Built
Environment, University of the Witwatersrand, in partial fulfilment of the
requirements for the degree of Master of Science in Engineering**

Johannesburg, 2016

ABSTRACT

The power system frequency must be kept as close as possible to the nominal value. This is due to the inherent design of electrical equipment to operate efficiently at the nominal frequency. Frequency regulation in an interconnected power system is the duty of all members of the interconnection. However, in the Eskom-ZESA interconnected power system Eskom engineers ignore the contribution of the ZESA system to primary frequency control. This is mainly due to the prevalent assumption that the ZESA control area is small relative to the Eskom control area and its contribution to primary frequency control of the interconnected power system is negligible. This document presents a project that examines the validity of this assumption via determination of the contribution of the ZESA system to the interconnected power system's primary frequency control.

The interconnected power systems background was studied to understand the theory behind the operation of two or more interconnected power systems. System frequency disturbances deemed to be a good representation of the Eskom-ZESA interconnected power system's performance were selected and analysed to validate the current assumption. The results show that there is a significant support from ZESA during a system frequency disturbance. This proves that the existing assumption is not valid anymore.

Furthermore; the generator model that mimics the Eskom-ZESA tie-line governing behaviour was developed. Two different types of governor models were employed; firstly the IEEE1 governor was tuned to control generator output to match the tie-line performance and then the TGOV5 governor model was used. The IEEE1 governor model is a simplified governor representation; as a result, it is not easy to tune the parameters to match tie-line response. However, the performance is acceptable and it can be used to represent the tie-line governor response. The TGOV5 governor model is very complex as discussed in section 4.2. The model includes boiler dynamics, and this improves performance such that it is possible to tune the parameters to follow the tie-line performance as close as necessary.

DECLARATION

I declare that this research report is my own work except as indicated in the references and acknowledgements. It is submitted in partial fulfilment of the requirements for the degree of Master of Science in the University of the Witwatersrand, Johannesburg. It has not been submitted before for any degree or examination in this or any other university.

Signed at

On the day of 20.....

DEDICATION

ACKNOWLEDGEMENTS

I would like to thank

School of Electrical and Information Engineering, University of Witwatersrand;

Dr John van Coller, academic supervisor for his valuable guidance;

Thabo Modisane, Brian Berry and Armien Edwards who helped me to initiate
this research;

Mpeli Rampokanyo, Mike Nene and my colleagues in Eskom who supported me
and constantly encouraged me to complete the research;

Eskom Transmission System Operator for providing the bursary, resources and
information required to complete the project.

TABLE OF CONTENTS

ABSTRACT	ii
DECLARATION.....	iii
DEDICATION	iv
ACKNOWLEDGEMENTS.....	v
LIST OF TABLES.....	ix
LIST OF FIGURES	x
CHAPTER 1. INTRODUCTION.....	1
1.1 PURPOSE OF THE STUDY	1
1.2 CONTEXT OF THE STUDY.....	1
1.3 PROBLEM STATEMENT	2
1.4 SIGNIFICANCE OF THE STUDY	3
1.5 RESEARCH QUESTIONS.....	3
1.6 DELIMITATIONS OF THE STUDY.....	3
1.7 DEFINITION OF TERMS	4
1.8 ASSUMPTIONS	5
CHAPTER 2. LITERATURE REVIEW AND THEORETICAL BACKGROUND 6	
2.1 FREQUENCY CONTROL	6
2.1.1 SYSTEM INERTIA.....	6
2.1.2 STEADY STATE POWER BALANCE IN ONE AREA	7
2.1.3 INTERCONNECTED POWER SYSTEMS.....	8
2.1.4 TWO AREA SYSTEMS.....	9
2.1.5 DROOP BACKGROUND DISCUSSION.....	10
2.2 LITERATURE REVIEW [4][5][6][7][8].....	11
CHAPTER 3. UNDERSTANDING SYSTEM REQUIREMENTS AND PERFORMANCE EVALUATION	13
3.1 GRID CODE REQUIREMENTS	13
3.2 SAPP OPERATING GUIDELINES REQUIREMENTS.....	13
3.3 SYSTEM BEHAVIOUR.....	14
3.4 PRIMARY FREQUENCY CONTROL IN ESKOM.....	16

3.4.1	GOVERNING RESPONSE	17
3.4.2	DEMAND RESPONSE (DR)	17
3.5	ESKOM-ZESA TIE-LINE BEHAVIOUR DURING DISTURBANCES	19
3.5.1	TIE-LINE TRIP	19
3.5.2	GOVERNING RESPONSE	20
3.5.3	TIE LINE POWER CHANGES DIRECTION	21
3.6	CALCULATING THE ESKOM-ZESA TIE-LINE RESPONSE TO FREQUENCY DEVIATIONS USING TEMSE DATA	22
3.6.1	SELECTION OF SYSTEM DISTURBANCES	22
3.6.2	ESKOM-ZESA TYPICAL RESPONSE TO FREQUENCY DEVIATIONS.....	23
3.7	FACTORS INFLUENCING TIE LINE BEHAVIOUR.....	26
3.7.1	AUTOMATIC GENERATION CONTROL (AGC).....	26
3.7.2	GMPC IN CAHORA BASSA	29
3.7.3	HVDC TYPICAL RESPONSE TO FREQUENCY DEVIATIONS	34

CHAPTER 4. MODEL DEVELOPMENT AND VERIFICATION ... 37

4.1	INTRODUCTION	37
4.2	PLANT MODEL FRAME COMPONENTS	38
4.2.1	GOVERNOR SYSTEM.....	38
4.2.2	POWER SYSTEM STABILIZER (PSS)	40
4.2.3	AVR AND EXCITATION	41
4.3	GRID USED TO TUNE THE GENERATOR MODEL	41
4.4	EDITING FRAME FOR TUNING PURPOSES.....	43
4.5	GENERATOR GOVERNOR TUNING STRATEGY	43
4.6	SIMULATION RESULTS.....	44
4.7	SUMMARY OF THE RESULTS	47

CHAPTER 5. CONCLUSIONS & RECOMMENDATIONS 49

5.1	INTRODUCTION	49
5.2	CONCLUSIONS FROM THE STUDY	49
5.3	RESEARCH QUESTIONS.....	49
5.3.1	WHAT DYNAMIC BEHAVIOUR MUST BE EXAMINED IN THE PROPOSED STUDY?	50
5.3.2	WHAT FACTORS INFLUENCE THE SPECIFIC ESKOM-ZESA INTERCONNECTION DYNAMIC BEHAVIOUR?	50
5.3.3	WHAT IMPROVEMENTS CAN BE MADE TO THE WAY THE ESKOM-ZESA INTERCONNECTION IS PRESENTLY OPERATED?	51
5.4	RECOMMENDATIONS	51
5.5	SUGGESTIONS FOR FURTHER RESEARCH	51

REFERENCES 53

APPENDIX A: LITERATURE REVIEW AND THEORETICAL BACKGROUND..... 55

A1	FREQUENCY CONTROL BACKGROUND DISCUSSION.....	55
A1.1	INERTIA.....	55

A1.2 STEADY STATE POWER BALANCE IN ONE AREA	56
A2 GENERATOR RESPONSE TO LOAD CHANGE	57
A3 LOAD RESPONSE TO FREQUENCY DEVIATION	59
A4 INTERCONNECTED SYSTEMS THEORY	61
A5 GOVERNOR WITH SPEED DROOP	62
A6 EQUIVALENT PLANT REPRESENTING AREA	64
A7 LITERATURE REVIEW	65

APPENDIX B: SYSTEM REQUIREMENTS AND PERFORMANCE EVALUATION 67

B1 SOUTH AFRICAN GRID CODE REQUIREMENTS	67
B1.1 GOVERNOR REQUIREMENTS	67
B1.2 FREQUENCY DEAD-BAND REQUIREMENTS	67
B1.3 DROOP SETTINGS REQUIREMENTS.....	68

APPENDIX C: MODEL DEVELOPMENT AND VERIFICATION ... 69

LIST OF TABLES

Table 3.1 Eskom-ZESA frequency response analysis	26
Table 3.2 AGC modes and corresponding ACE.....	27
Table C.0.1 Governor system's typical time constants.....	69
Table C.0.2 IEEEG1 parameters [14].....	70
Table C.0.3 IEEEG1 parameters on DlgSILENT simulation package	71
Table C.0.4 TGOV5 default parameters on DlgSILENT simulation package ...	73
Table C.0.5 Steam turbine parameters	74
Table C.0.6 Translation of steam turbine parameters to general model.....	74
Table C.0.7 TGOV5 (without dead band) model parameters	75
Table C.0.8 TGOV5 (with dead band) model parameters	76

LIST OF FIGURES

Figure 1.1 Southern Africa Power Pool (SAPP) interconnection	2
Figure 2.1 System equivalent for LFC analysis [2]	8
Figure 2.2 Two area system and electrical equivalent [2].	9
Figure 2.3 Two area system block diagram with primary speed control only [2].	10
Figure 2.4 Ideal steady-state characteristics of a governor with speed droop [3]	11
Figure 3.1 Eskom-ZESA interconnection normal frequency profile	14
Figure 3.2 Eskom-ZESA typical disturbance profile	15
Figure 3.3 Frequency trace (4 seconds resolution)	16
Figure 3.4 Instantaneous Reserves from online generating unit	17
Figure 3.5 Instantaneous Reserves from demand response.....	18
Figure 3.6 Eskom-ZESA tie-line trip during frequency disturbance.....	19
Figure 3.7 Tie-line power flow during frequency disturbance	20
Figure 3.8 Tie-line power flow changes direction during frequency disturbance	21
Figure 3.9 Event 1 frequency response	23
Figure 3.10 Event 2 frequency response	24
Figure 3.11 Event 3 frequency response	25
Figure 3.12 Generator unit governing response while on AGC	28

Figure 3.13 Cahora Bassa-ZESA-Eskom interconnection [12].....	29
Figure 3.14 Songo substation single line diagram.....	30
Figure 3.15 GMPC software overview [12].....	33
Figure 3.16 HVDC performance during event 1	34
Figure 3.17 HVDC performance during event 2	35
Figure 3.18 HVDC performance during event 3	36
Figure 4.1 Plant model frame structure	37
Figure 4.2 Mechanical-Hydraulic Speed governing system for steam turbine functional block diagram [13].....	38
Figure 4.3 TGOV1 steam turbine model [14].....	39
Figure 4.4 IEESG0 steam turbine model [14].....	39
Figure 4.5 IEEEG1 model	40
Figure 4.6 Grid used to tune generator to the mimic tie-line behaviour.....	42
Figure 4.7 Steady state simulation run.....	42
Figure 4.8 Edited plant model frame structure	43
Figure 4.9 Block diagram of model tuning.....	44
Figure 4.10 Event 1 IEEEG1 governor model simulation result	45
Figure 4.11 Event 1 TGOV5 governor model (without frequency dead band) simulation results	45
Figure 4.12 Event 2 TGOV5 governor model (without frequency dead band) simulation.....	46
Figure 4.13 Event 1 TGOV5 governor model (with frequency dead band) simulation results	47

Figure 4.14 Event 2 TGOV5 governor model (with frequency dead band) simulation results	47
Figure A.0.1 Generator supplying isolated load [2]	55
Figure A.0.2 Transfer function relating speed and torques [2].....	58
Figure A.0.3 Transfer function relating speed and power [2].....	58
Figure A.0.4 Rotor dynamics transfer function [2]	59
Figure A.0.5 Standard form block diagram.....	59
Figure A.0.6 System without governor	60
Figure A.0.7 Governor system equipped with droop characteristic [2]	63
Figure A.0.8 Time response of a generating unit with a governor having speed-droop characteristic [2].....	64
Figure A.0.9 Block diagram of the generating unit [2]	65
Figure B.0.1 Graphical representation of governing requirements [15]	68
Figure C.0.1 General model for steam turbine speed governor system [13]	69
Figure C.0.2 TGOV5 block diagram [14]	72
Figure C.0.3 General steam turbine model	74

CHAPTER 1. INTRODUCTION

1.1 Purpose of the study

The purpose of this research project was to study the Eskom-ZESA interconnected power system to understand its behaviour during frequency disturbances and quantify ZESA's contribution in the governing response and then develop a model that represents its performance. The main contributions of the study were:

- Simulation of the two-area system using PowerFactory as a tool
- Examine the Eskom-ZESA tie-line performance under various conditions

1.2 Context of the study

The diagram below shows how Eskom is interconnected with the neighbouring control areas. It is clear that Eskom is connected to Mozambican utility (HCB) through a High Voltage Direct Current (HVDC) line and to the Zimbabwean utility (ZESA) through an Alternating Current (AC) tie-line. In HCB, AC power is generated using hydro-generators. Some of the power is transmitted to ZESA in AC form and the bulk of the power is converted to Direct Current (DC) and then transmitted to Eskom. The whole interconnection is called the Southern African Power Pool.

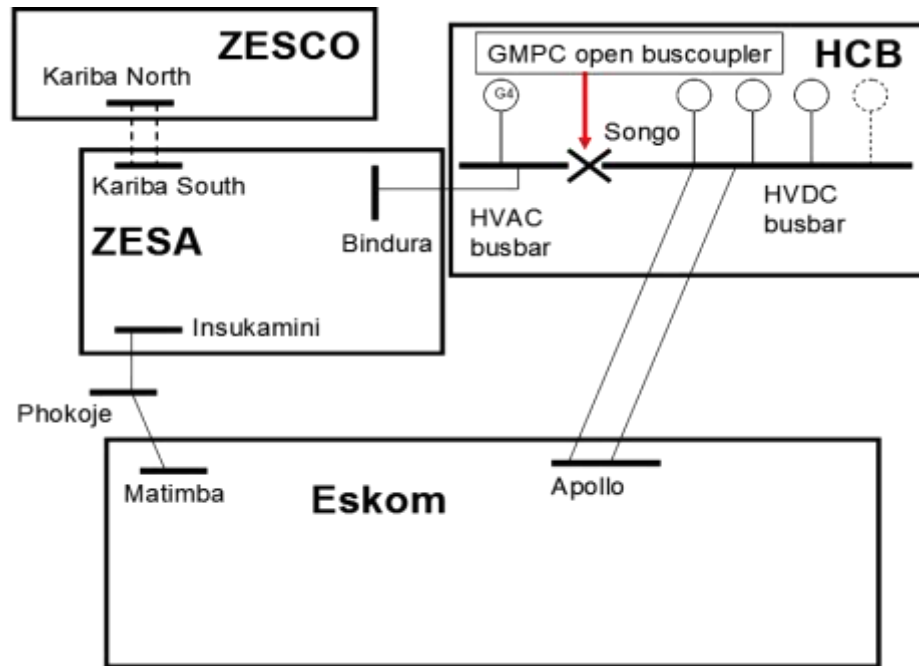

Figure 1.1 Southern Africa Power Pool (SAPP) interconnection

In the existing Eskom model, HVDC is modelled as a negative load; therefore the focus is on the Eskom-ZESA tie-line. Since the HVDC link is modelled as a negative load, the system shown in Figure 1.1 can be represented as a two-area system. In interconnected power systems, frequency regulation is the duty of all members; therefore ZESA’s contribution to the interconnected power system’s governing response will be quantified in the study.

1.3 Problem statement

In interconnected power systems, frequency regulation is the duty of all members. However, in the Eskom-ZESA interconnected power system Eskom engineers ignore ZESA’s contribution to primary frequency control. This is mainly due to the assumption that the ZESA control area is small relative to the Eskom control area and its contribution to the primary frequency control of the interconnected power system is negligible. The study was initiated to examine this assumption’s validity. The current assumption’s validity was examined by quantifying ZESA’s contribution to the interconnected power system’s dynamic performance.

The Eskom control area is currently experiencing extreme capacity constraints and this result in a shortfall in reserves availability. There is a need to quantify reserves provision from neighbouring utilities so that Eskom will be aware of the support available from other SAPP members.

1.4 Significance of the study

The study validates the existing assumption on the Eskom-ZESA interconnected power system dynamic performance and develops a model that represents the Eskom-ZESA tie-line response during frequency disturbances.

1.5 Research questions

To validate the existing assumption the following research questions were considered:

1. What dynamic behaviour must be examined in the proposed study?
2. What factors influence the specific Eskom-ZESA interconnected power system dynamic behaviour?
3. What improvements can be made to the way the Eskom-ZESA interconnected power system is presently operated?

1.6 Delimitations of the study

The study was initiated to quantify the governing response contribution of ZESA to the interconnected power system. Hence the focus was on evaluating and modelling the governing response of the ZESA system (observed through the Eskom-ZESA tie-line). The Automatic Generation Control (AGC) system was not modelled because it is slow and does not contribute to primary frequency control; the study was focussed on primary frequency control.

The study is limited to typical (small) system frequency disturbances. Severe disturbances that may lead to AC and DC system split at Songo were not considered. Hence the Songo bus coupler behavior was not included in the dynamic performance.

1.7 Definition of terms

Abbreviation	Explanation
ACE	Area control error
AGC	Automatic generation control
DB_high	Frequency dead-band high limit/boundary
DB_low	Frequency dead-band low limit/boundary
DR	Demand response
EMS	Energy management system
Eskom	(not abbreviation – electricity utility of South Africa)
GMPC	Grid master power controller
HCB	Hydroelectric Cahora Bassa
IR	Instantaneous reserves
SAPP	Southern African Power Pool
SCADA	Supervisory control and data acquisition
TLBC	Tie-line bias control

ZESA	Zimbabwe Electricity Supply Authority
------	---------------------------------------

1.8 Assumptions

- The Grid Master Power Controller (GMPC) action is included in the Eskom-ZESA tie-line response for small frequency deviations.
- AGC action is not considered because it acts outside the time of primary frequency control (governing action).
- Eskom control area's governing performance is known and understood, so the focus is on the ZESA response (observed through the tie-line).
- Any governing response observed in the Eskom-ZESA tie-line is assumed to be coming from the ZESA control area.

CHAPTER 2. LITERATURE REVIEW AND THEORETICAL BACKGROUND

2.1 Frequency control

2.1.1 *System inertia*

The frequency of a power system is dependent on the real power (MW) balance. In steady state, all alternators are generating at the same frequency and constant phase angle. A change in real power demand at one point of the network is reflected throughout the system by a change in frequency. When the system generation and load imbalance occurs, the generation should be increased or decreased to meet the load demand. Significant loss in generation without an adequate system response can produce extreme frequency excursions outside the working range of the plant [1].

In an interconnected power system with two or more independently controlled areas, generation within each area has to be controlled to control frequency and to maintain scheduled power interchange [2]. The control of frequency and power generation is commonly referred to as Load-Frequency Control (LFC). The real power delivered by the generator is controlled by the mechanical power output of a prime mover such as steam turbine, gas turbine, hydro-turbine or diesel engine. The basic concept of primary frequency control (speed governing) is illustrated in Appendix A. The combined inertia of the generator and the prime mover is accelerated by the unbalance in the applied torques as per the equation of motion.

$$T_a = T_m - T_e \quad (2.1)$$

Where T_a is the acceleration torque

T_m is the mechanical torque

T_e is the electrical torque

2.1.2 *Steady state power balance in one area*

A fundamental principle of power system operation is that the total demand (load + losses) must equal the total system generation for constant speed. If the system under consideration is interconnected with other systems, power flow through the tie-lines must be included in the power balance equation [2]. When there is a load change, it is reflected instantaneously as a change in the electrical torque T_e of the generator. This causes a mismatch between the mechanical torque T_m and the electrical torque T_e which in turn results in speed variations as determined by the equation of motion.

In case of the unbalance, generation should be increased or decreased in order to meet the demand. When the generation cannot be increased, load curtailment or load shedding is activated to establish the balance. In a system with one generator

$P = D$; generation (P) is equal to the demand, D (in MW)

$f = f_0$; frequency (f) is equal to the nominal value, f_0 (in Hz)

There is a solution as long as the demand is less than P_{max} . For a greater demand, a second generating unit should be connected to the system.

In a system with two generators (generator at P_1 and P_2):

$$P_1 + P_2 = D \quad (2.2)$$

$$f = f_0 \quad (2.3)$$

The generation cost of each unit could be different. For example hydro, thermal, nuclear etc. In that case it is important to fix the maximum generation at the cheapest generating unit. This is known as the base load unit. The variable part of the load is carried by the expensive unit.

2.1.3 Interconnected power systems

A control area is a region where internal generation is responsible for meeting its internal load commitment. A collection of control areas with free flowing ties is called a power pool. A combination of interconnected control areas with monitored and controlled ties is called an interconnected power system [2].

In the analysis of Load Frequency Controls (LFCs), the focus is in the collective performance of all the generators in the system. The inter-machine oscillations and transmission system performance are therefore not considered [2]. A coherent response of all generators to system changes is assumed and then all generators are represented by an equivalent generator. The equivalent generator has an inertia constant M_{eq} , which is equal to the sum of the inertia constants of all generating units. It is driven by the combined mechanical outputs of the individual turbines as shown below.

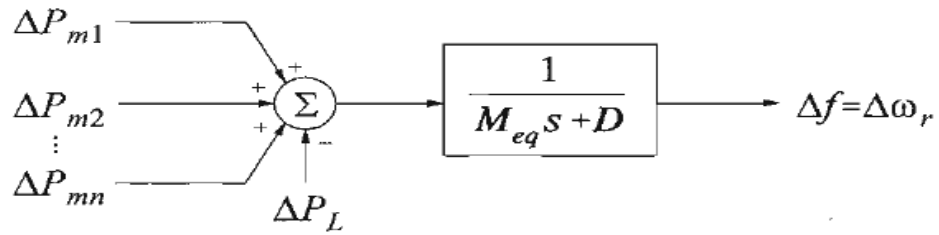

Figure 2.1 System equivalent for LFC analysis [2]

The effects of the system loads are lumped into a single damping constant D . The speed of the equivalent generator represents the system frequency. The frequency characteristic of the power system depends on the combined effect of the droops of all the generator speed governors. It also depends on the frequency characteristic of all the loads in the system. For a system with x number of generators and a composite load damping constant of D , the steady state frequency deviation following a load change ΔP_L is given by

$$\Delta f_{SS} = \frac{\Delta P_L}{\left(\frac{1}{R_1} + \frac{1}{R_2} + \dots + \frac{1}{R_x}\right) + D}$$

$$\Delta f_{SS} = \frac{\Delta P_L}{\frac{1}{R_{eq}} + D} \quad (2.4)$$

Where $R_1, R_2 \dots R_x$ is the droop settings for the generator $G_1, G_2 \dots G_x$

R_{eq} is the equivalent droop settings of the control area

2.1.4 Two area systems

Power systems are interconnected to improve security. An electrical power system consists of many generating units and loads and the total demand varies throughout the day. As the load changes randomly, the area frequency and tie-line power interchange also vary. Load changes are compensated using frequency control mechanisms to maintain the system frequency at the scheduled value and maintain the net power interchanges with neighbouring control areas at their scheduled values.

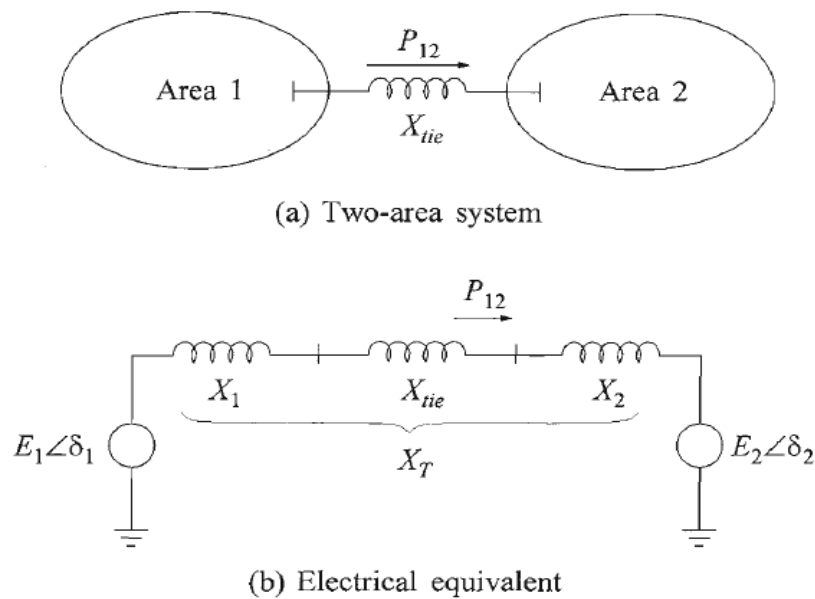

Figure 2.2 Two area system and electrical equivalent [2].

Figure 2.2 above depicts the interconnected power system which consists of two areas connected by a tie-line of reactance X_{tie} . For load-frequency studies, each area can be represented by an equivalent generating unit exhibiting its overall performance as shown in Figure 2.3.

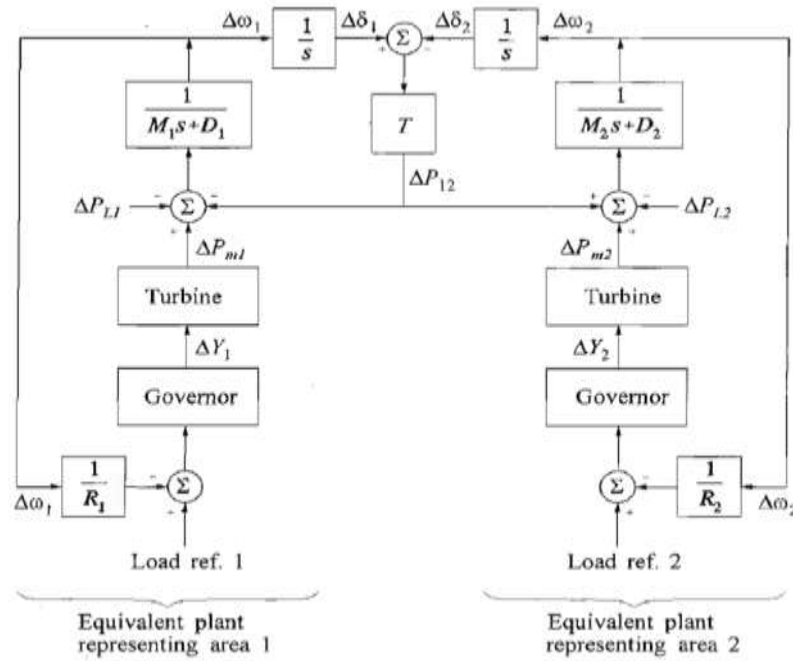

Figure 2.3 Two area system block diagram with primary speed control only [2].

Figure 2.3 above depicts a block diagram representation of the system with each area represented by an equivalent inertia M , load damping D , turbine and governing system with an effective speed droop R . The tie-line is represented by the synchronizing torque coefficient T . The steady state frequency deviation ($f - f_0$) is the same for the two areas.

$$\Delta f = \Delta \omega_1 = \Delta \omega_2 = \frac{\Delta P_L}{\left(\frac{1}{R_1} + \frac{1}{R_2}\right) + (D_1 + D_2)} \quad (2.5)$$

In the interconnected power systems, the load frequency control scheme has to be with two main control loops.

2.1.5 Droop background discussion

The droop (R) feature provides the system self-regulation to some extent [3]. It is the ratio of frequency deviation (Δf) to change in power output (ΔP). Droop determines the steady-state speed versus load characteristic of the generating unit.

$$R = -\frac{\Delta f}{\Delta P_m} = \frac{f-f_0}{P_0-P_m} \quad (2.6)$$

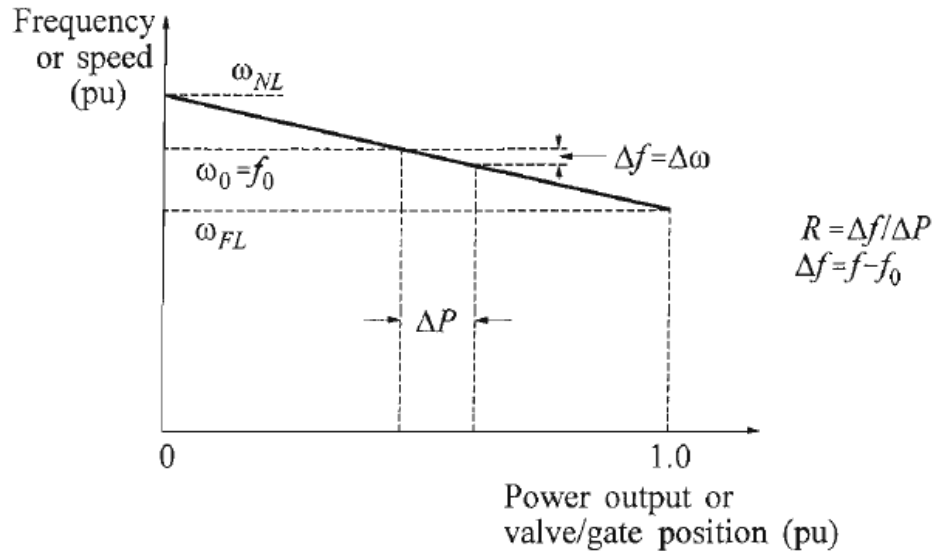

Figure 2.4 Ideal steady-state characteristics of a governor with speed droop [3]

The units of R are Hz/MW when Δf is in Hz and ΔP is in MW . However, if Δf and ΔP are given in per unit; R is also in per unit. The typical value for R is 4%, meaning that a 4% change in frequency will result in a 100% change in P_m . If the droop of all generating units in the system is 4%, all units will tend to share load changes equally in terms of percentages of their respective ratings.

2.2 Literature review [4][5][6][7][8]

Modern power systems normally consist of interconnected areas where each area has its own control center. Some of the advantages of interconnections are:

- Interconnected areas can share reserves to handle peak loads and unanticipated generator outages.
- Interconnected areas can tolerate large load changes with smaller deviations compared to isolated areas.

The literature shows that most researchers use a generic two-area power system model when performing multi-area system dynamic studies. However, systems are not the same; therefore the model cannot be used to represent all systems. Initially it was thought that the generic two-area system model cannot work without modification in the case of the Eskom-ZESA power system because of the bus coupler protection setting which has a direct impact on the tie-line dynamic performance. The idea was that the modifications will be done on the generic model to develop a model that represents the Eskom-ZESA dynamic performance. However, after a thorough analysis of the HCB-ZESA-Eskom interconnection explained in Section 3.7.2 it was clear that the bus coupler behaviour can be excluded from the study (assume permanently closed).

CHAPTER 3. UNDERSTANDING SYSTEM REQUIREMENTS AND PERFORMANCE EVALUATION

3.1 Grid code requirements

For governor requirements the relevant clause in the South African Grid Code is Grid Code Requirements 6 (GCR 6) of the Network Code. This clause states that all units above 50 MVA shall have an operational governor capable of responding according to the minimum requirements set out in GCR 6. The Network Code stipulates that the maximum allowable dead band shall be 0.15 Hz for governing units contracted for instantaneous reserves and 0.5 Hz for units not contracted for instantaneous reserves. More importantly, no response is required from online generators while the system frequency is within the dead band. It is also stipulated that the governor shall be set to give a 4% droop characteristic. Coal-fired units not equipped with a dead band facility shall have a droop of 10% or less. These are the important Grid Code requirements for the project.

3.2 SAPP Operating Guidelines requirements

SAPP Operating Guidelines state “Generating units with nameplate ratings of 5 MVA or greater should be equipped with governors operational with a droop between 2% and 10% with an initial setting of 4% for Frequency Response to ensure that the Control Area continuously adjusts its generation to its load plus its net scheduled interchange unless restricted by regulatory mandates. Any change from the initial 4% setting shall be approved by the Operating Sub-Committee.”[9]. It also states that the frequency dead band for the governors on generators shall be set to less than ± 0.15 Hz. Lastly, the SAPP Operating Guidelines say all turbine governors should, as a minimum, be fully responsive to frequency deviations exceeding ± 0.15 Hz according to the appropriate droop characteristics. Effectively, the Southern African Power Pool (SAPP) governor settings requirements and the South African Grid Code governor settings

requirements are the same. The Eskom’s representative at the Southern African Power Pool (SAPP) confirmed that ZESA does not have a Grid Code in place; they adopt the SAPP Operating Guidelines and the South African Grid Code requirements.

3.3 System behaviour

The mismatch between the mechanical power fed into the generators and the active power consumed by loads and losses is balanced by reducing or increasing the energy stored in the rotating masses in the power system. Small deviations from nominal frequency (as shown in Figure 3.1) are normal and should not affect behaviour of any component in the network. Generator governors are not expected to act while system frequency is within the dead band (49.85 Hz – 50.15 Hz).

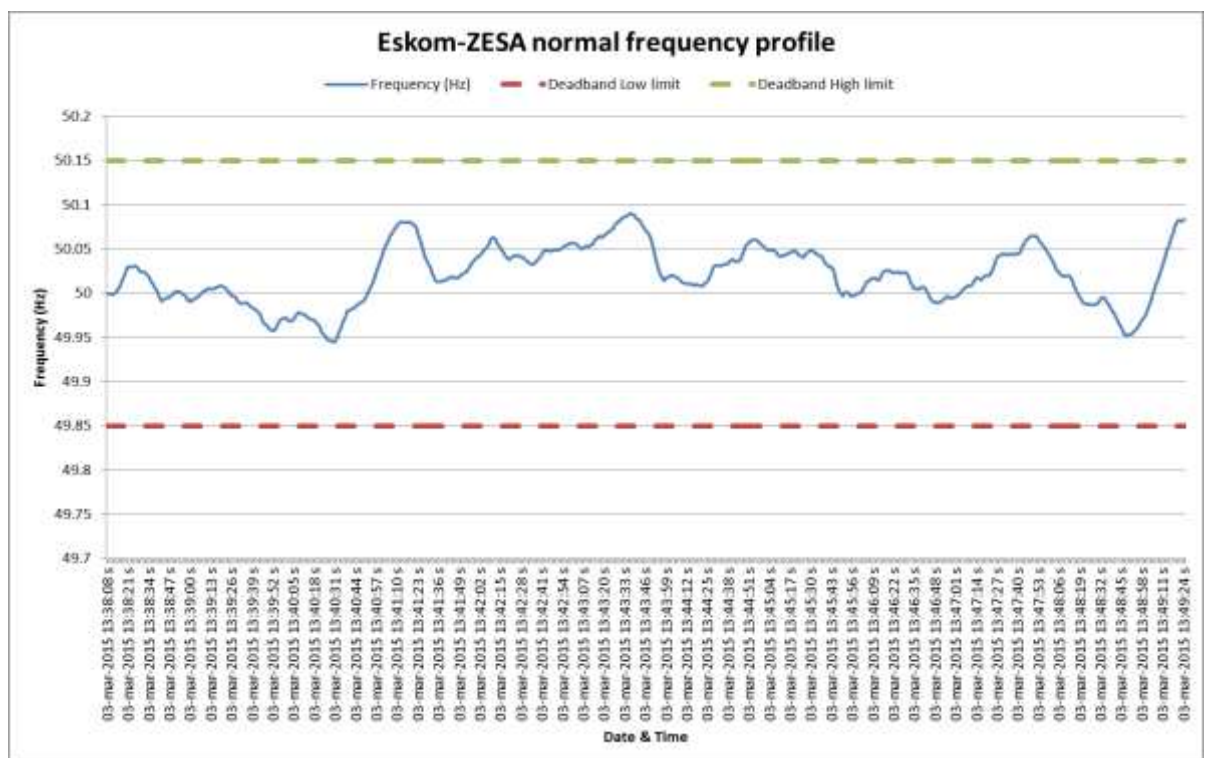

Figure 3.1 Eskom-ZESA interconnection normal frequency profile

A sudden loss of power produced by one or more generators in the power system is compensated by other generators releasing energy stored in the inertia of their rotating masses. This is somewhat counteracted by the self-

regulation effect of loads, leading to a reduced consumption of electrical power at decreased frequencies. As a result of this effect, a new steady state will be reached at a lower frequency.

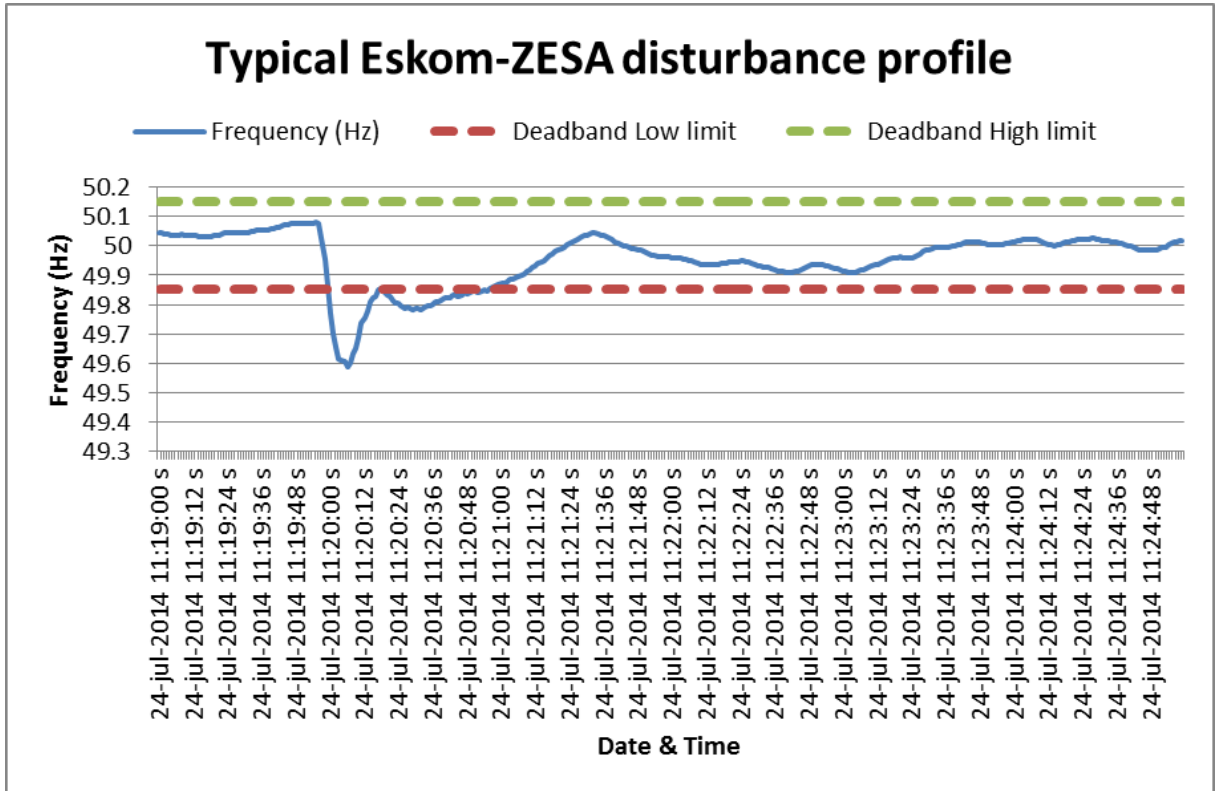

Figure 3.2 Eskom-ZESA typical disturbance profile

The sum of the effect of speed droop governing and self-regulation of loads determines the steady state frequency deviation after a disturbance; this is called frequency response characteristic (FRC) and is labelled as β [1].

$$\beta = (1/R) + D \quad (3.1)$$

Where,

$1/R$ is the generator regulation or droop

D is the load damping characteristic

Consider Figure 3.3 below. From the frequency trace, NERC in [10] references three key events to describe power system disturbance. Point A is the pre-disturbance frequency, point C is the maximum excursion point and point B is

the settling frequency of the power system. The same approach was adopted for calculation of the Eskom-ZESA tie-line response during disturbances.

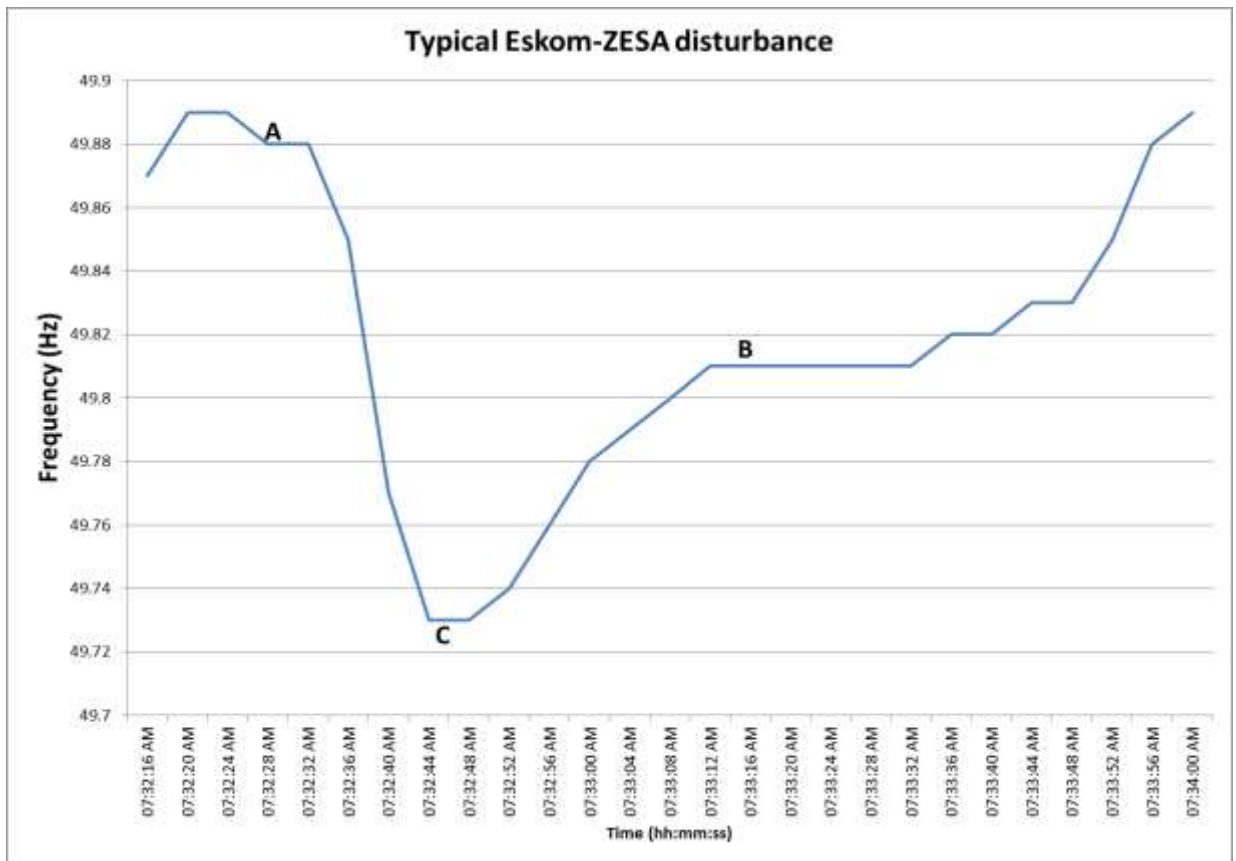

Figure 3.3 Frequency trace (4 seconds resolution)

3.4 Primary frequency control in Eskom

Primary frequency control is needed to arrest a frequency fall within acceptable limits following a contingency such as a generator trip or a sudden surge in load as per SAGC and SAPP Operating Guidelines requirements. In the Eskom system, primary frequency control is referred to as Instantaneous Reserves (IR). It is provided by online generators (generation instantaneous reserve) and demand response. In response to a frequency deviation, the available IR capacity is activated automatically via direct control at the resource (generator unit or customer site). It responds fully within 10 seconds and the response is proportional to the system frequency deviation. Primary frequency control interventions are staggered to achieve optimal performance.

3.4.1 Governing response

An online generator's governing response is activated as soon as the system frequency is outside the dead band (49.85 Hz – 50.15 Hz) as per Grid Code requirements. The governor senses power system frequency deviations and initiates adjustments to the mechanical input power of the generator to increase or decrease the system frequency as required. A typical generator response is shown in the diagram below.

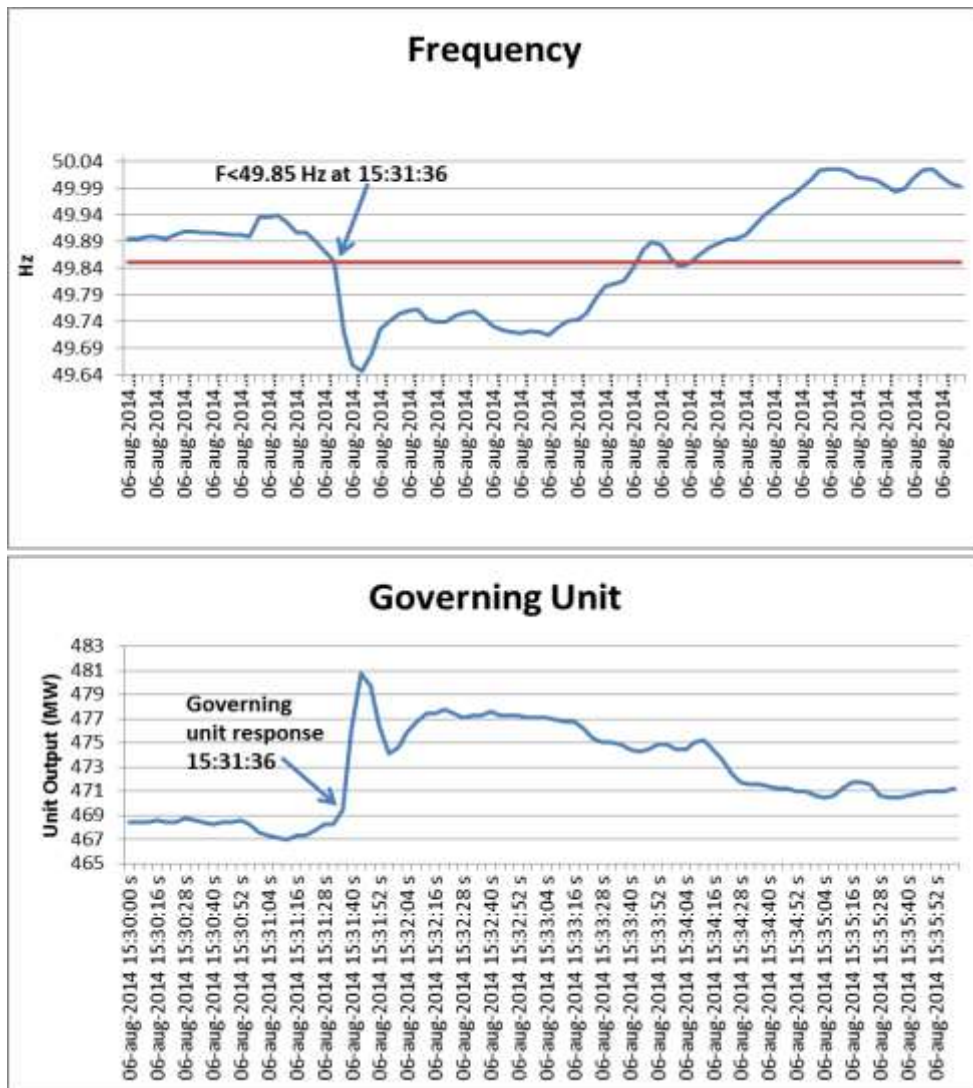

Figure 3.4 Instantaneous Reserves from online generating unit

3.4.2 Demand Response (DR)

According to the Federal Energy Regulatory Commission (FERC), Demand Response (DR) is the change in usage by demand-side resources from their

normal consumption patterns in response to changes in the price of electricity over time, or to incentive payments designed to induce lower electricity use at times of high wholesale market prices or when system reliability is jeopardized (such as a large drop in frequency). In Eskom, DR is used to induce low electricity usage at times when system reliability is jeopardized. Hence, it falls under ancillary services.

In Eskom, DR forms part of primary frequency control. Participants in DR are customers who have agreed to provide reserves by reducing load on request and have a valid service level agreement with Eskom. Instantaneous DR is the component of DR reserved for low frequency events and contingencies related to a loss of generation and subsequent declines in frequency.

Instantaneous DR is not dispatchable as it operates automatically via under-frequency relays. If the system frequency declines to below the predetermined threshold frequency setting (currently 49.65 Hz) for a specified time delay setting (currently 4s), the under frequency relays at all contracted instantaneous DR customer sites will operate to reduce the demand and arrest the frequency at acceptable limits. That load will remain off the system for ten minutes or until the system frequency is restored to above 49.85 Hz. A typical response of instantaneous DR is shown in Figure 3.5 below.

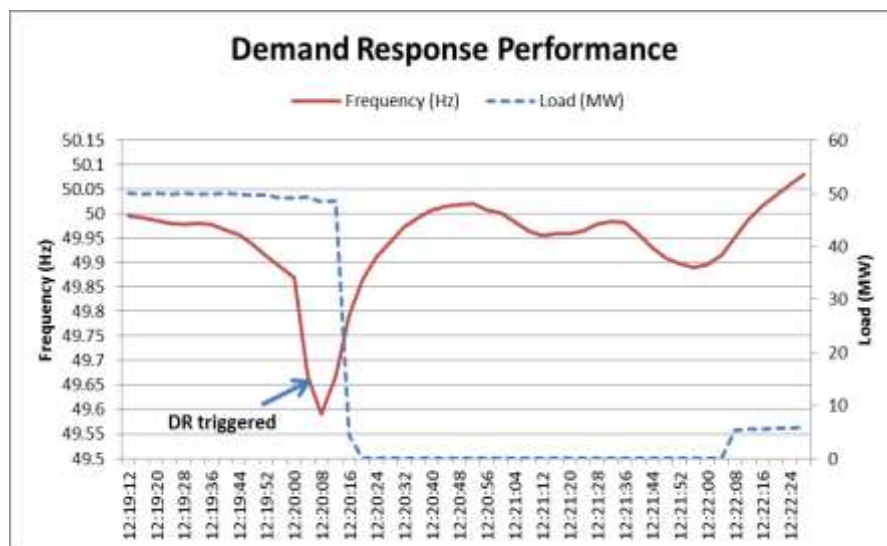

Figure 3.5 Instantaneous Reserves from demand response

3.5 Eskom-ZESA tie-line behaviour during disturbances

The Eskom-ZESA tie-line is an AC transmission line connecting the Eskom and ZESA control areas in the Southern African Power Pool. This line can import and export power to and from the Eskom area. Since one of the objectives of the study was to quantify ZESA's contribution to governing response during system frequency disturbances, the interest was on the tie-line behaviour when Eskom is importing power. When there is a loss of generation in the Eskom control area while tie-line is importing power, three things can happen.

- Tie-line trip
- Governing response
- Tie-line power flow change direction

3.5.1 Tie-line trip

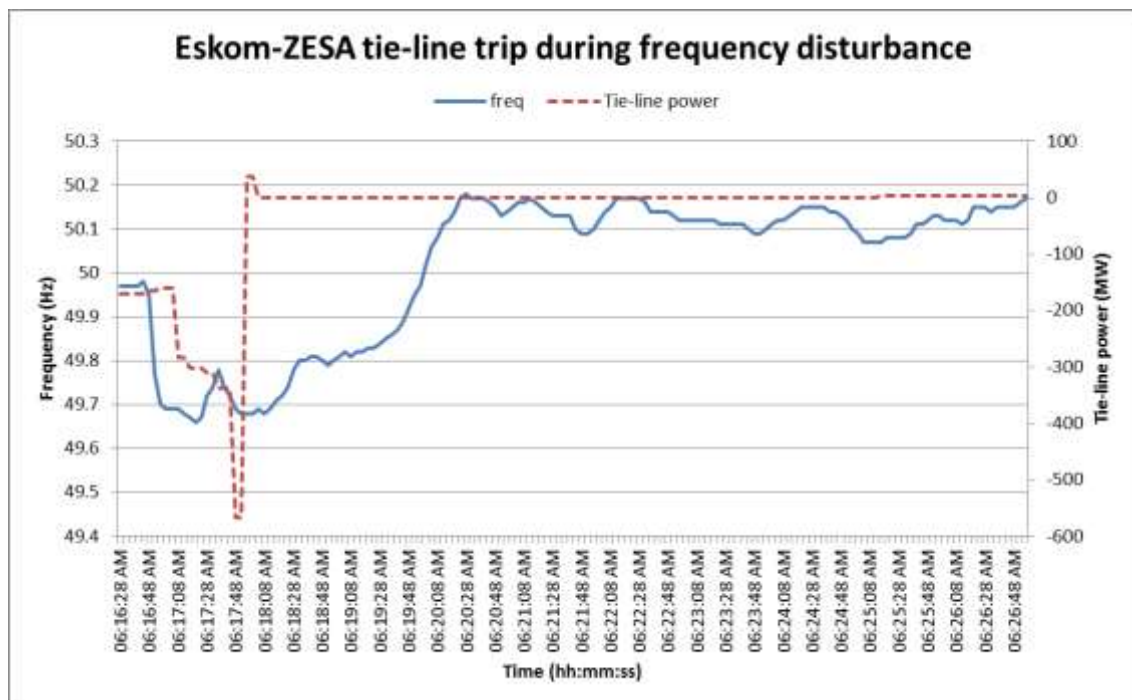

Figure 3.6 Eskom-ZESA tie-line trip during frequency disturbance

It is very possible that the tie-line can trip during system frequency disturbances. This would happen when the protective devices detect overload on the transmission line and then open the respective circuit breakers.

3.5.2 Governing response

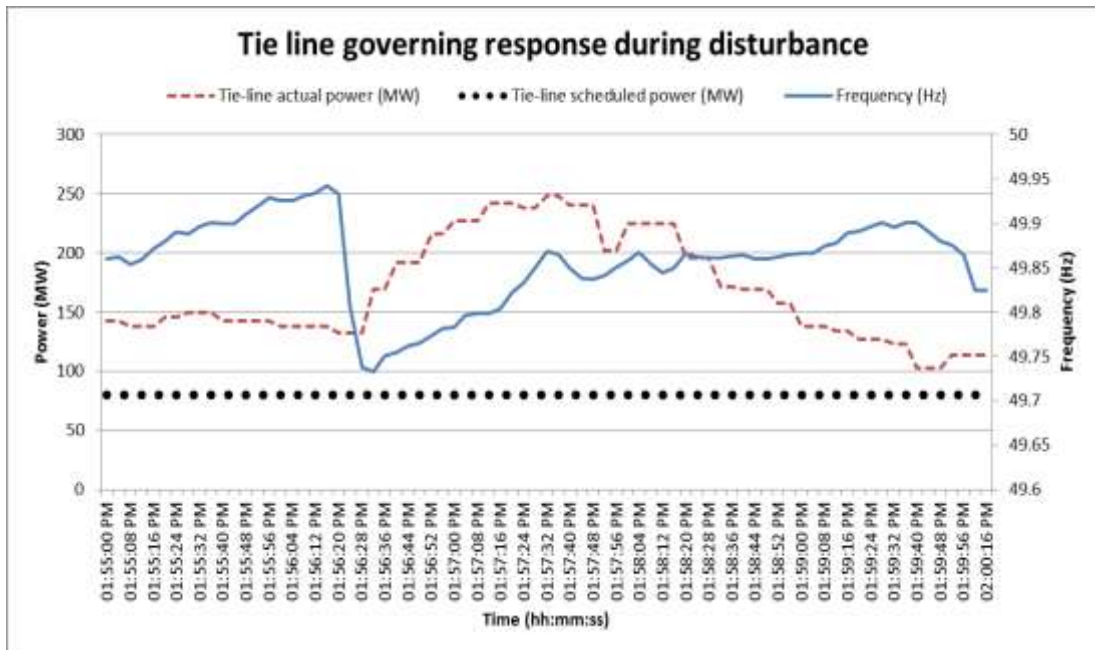

Figure 3.7 Tie-line power flow during frequency disturbance

This phenomenon can be explained using the interconnected systems theory explained briefly on Appendix A. An increase in the load or the loss of generation capacity in area 1 results in a frequency reduction in both areas and a tie-line power flow deviation. Figure 3.7 shows a system disturbance that occurred when the tie-line was scheduled to import 80 MW from the ZESA control area to the Eskom control area. Before the frequency disturbance, the tie-line power flow was slightly above the scheduled capacity. The frequency disturbance was caused by loss of 326 MW in the Eskom control area. As a result, the ZESA control area increased the export power (to Eskom) to arrest the frequency decay in the interconnected power system. This performance reflects the contribution of the regulation characteristics ($1/R + D$) of one area to another.

3.5.3 Tie line power changes direction

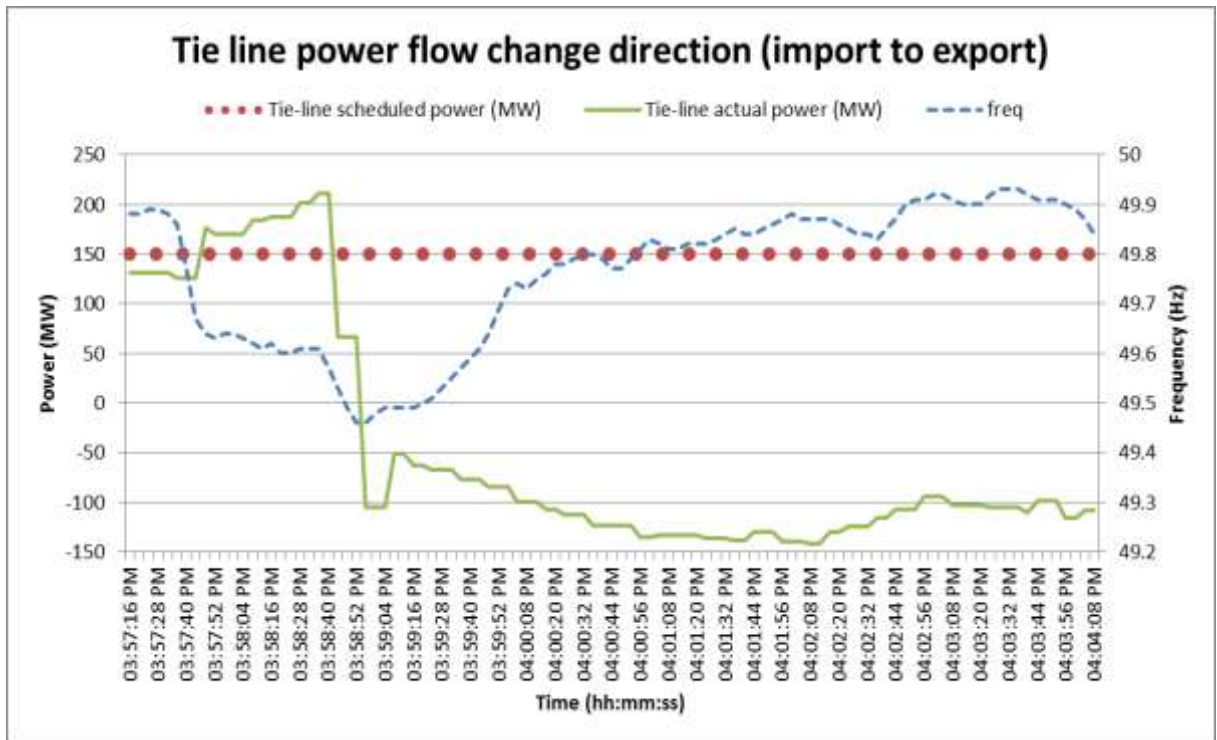

Figure 3.8 Tie-line power flow changes direction during frequency disturbance

Tie-line power flow direction reversal is experienced when the generation deficit occurs in the area that was exporting power before the frequency disturbance. Theoretically, when a significant amount of generation capacity trips in the area that was exporting power; the state of the interconnected power system will change completely. However, the phenomenon depicted on Figure 3.8 is not purely the contribution of regulation characteristics ($1/R + D$) of one area to another.

Figure 3.8 shows a system disturbance that occurred when the tie-line was scheduled to import 150 MW from the ZESA control area to the Eskom control area. Before the frequency disturbance, tie-line power flow was slightly below the scheduled value. The frequency disturbance was caused by the loss of 374 MW in the Eskom control area. The ZESA control area initially increased the export power (to Eskom) to arrest the frequency decay in the interconnected power system. System frequency was not recovered because of the reserves

shortage in the power system; therefore it settled around 49.60 Hz. The Grid Master Power Controller (GMPC) at Hydroelectric Cahora Bassa (HCB) power station then opened the bus coupler at Songo due the continued frequency error. After GMPC action, the GMPC control mode changes to frequency control mode. The power flow change from import to export is due to the GMPC action.

3.6 Calculating the Eskom-ZESA tie-line response to frequency deviations using TEMSE data

The Eskom National Control Centre uses the Transmission Energy Management System (TEMSE) to operate the power system. This system has a facility to store historical information for future reference or investigations. Only incidents in which the frequency before disturbance (pre-disturbance frequency) exceeds or equals 49.85 Hz (i.e. the frequency lies in the dead band of 50 ± 0.15 Hz) and minimum frequency is less than or equal to 49.75 Hz are archived. This is because there is an assumption that the full governor response occurs below 49.75 Hz due to the action of the response limiters in most units. Disturbances that satisfy these conditions are captured and archived in the system. However, not all disturbances are useful to evaluate system performance. Only a fraction of events can give a good representation of system performance. Therefore a criterion to choose those events was developed.

3.6.1 Selection of system disturbances

As discussed in Section 3.4, Eskom uses DR as part of primary frequency control. In this mechanism, the electricity user has an agreement with Eskom to automatically curtail consumption whenever the system frequency goes below a pre-set frequency threshold. The demand reduction from this mechanism has to be taken into account when evaluating frequency response i.e. the frequency disturbances where these mechanisms were used had to be ignored. Disturbances where the minimum frequency was just above 49.70 Hz were selected for analysis. The reason for using 49.70 Hz as a threshold is that there is minimum manual intervention during small disturbances. Secondly, demand

response frequency threshold is below 49.70 Hz. Only online generators are expected to respond to frequency disturbances of this nature.

3.6.2 Eskom-ZESA typical response to frequency deviations

The system frequency disturbances that can be used as a good representation of the interconnection’s response to frequency deviations were identified as explained above. Each frequency disturbance was caused by the loss of capacity shown on “Lost Power (MW)” column depicted in Table 3.1 below.

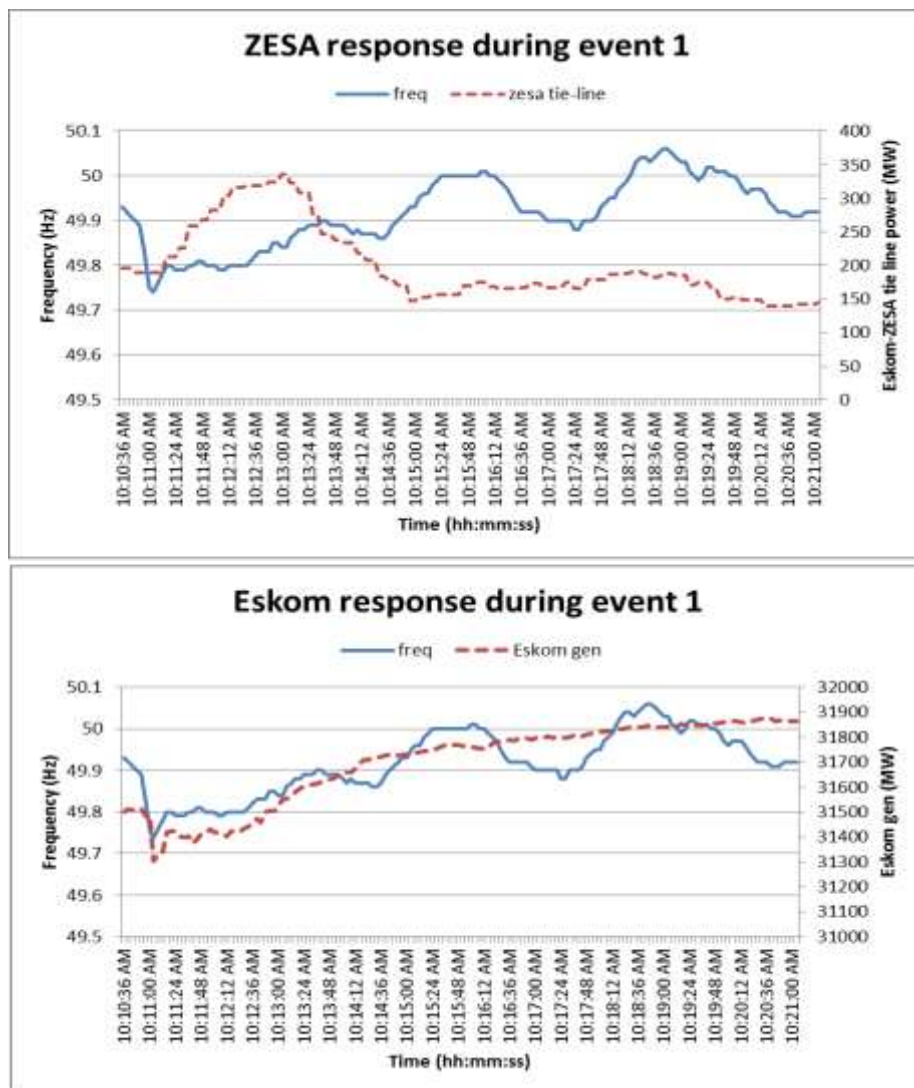

Figure 3.9 Event 1 frequency response

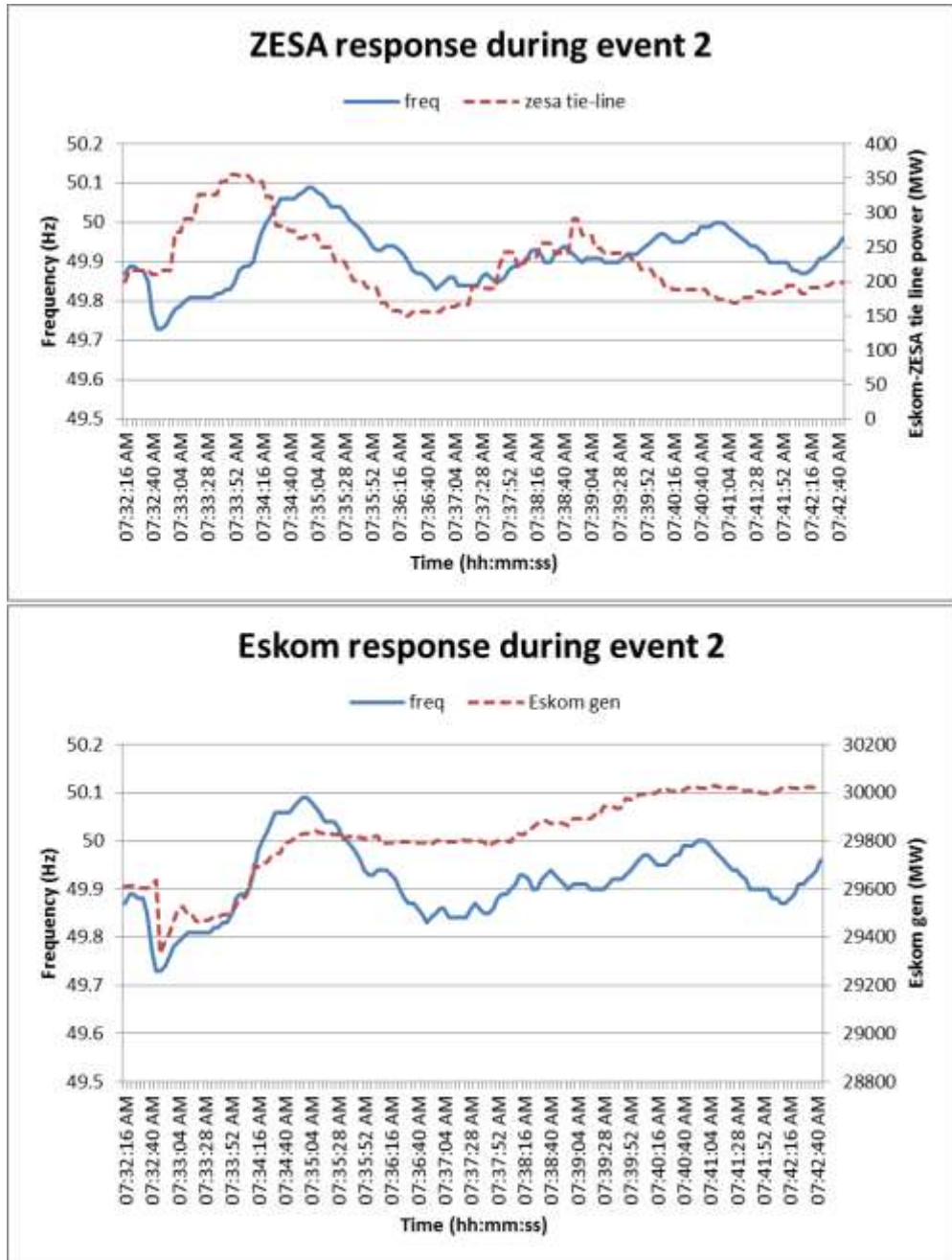

Figure 3.10 Event 2 frequency response

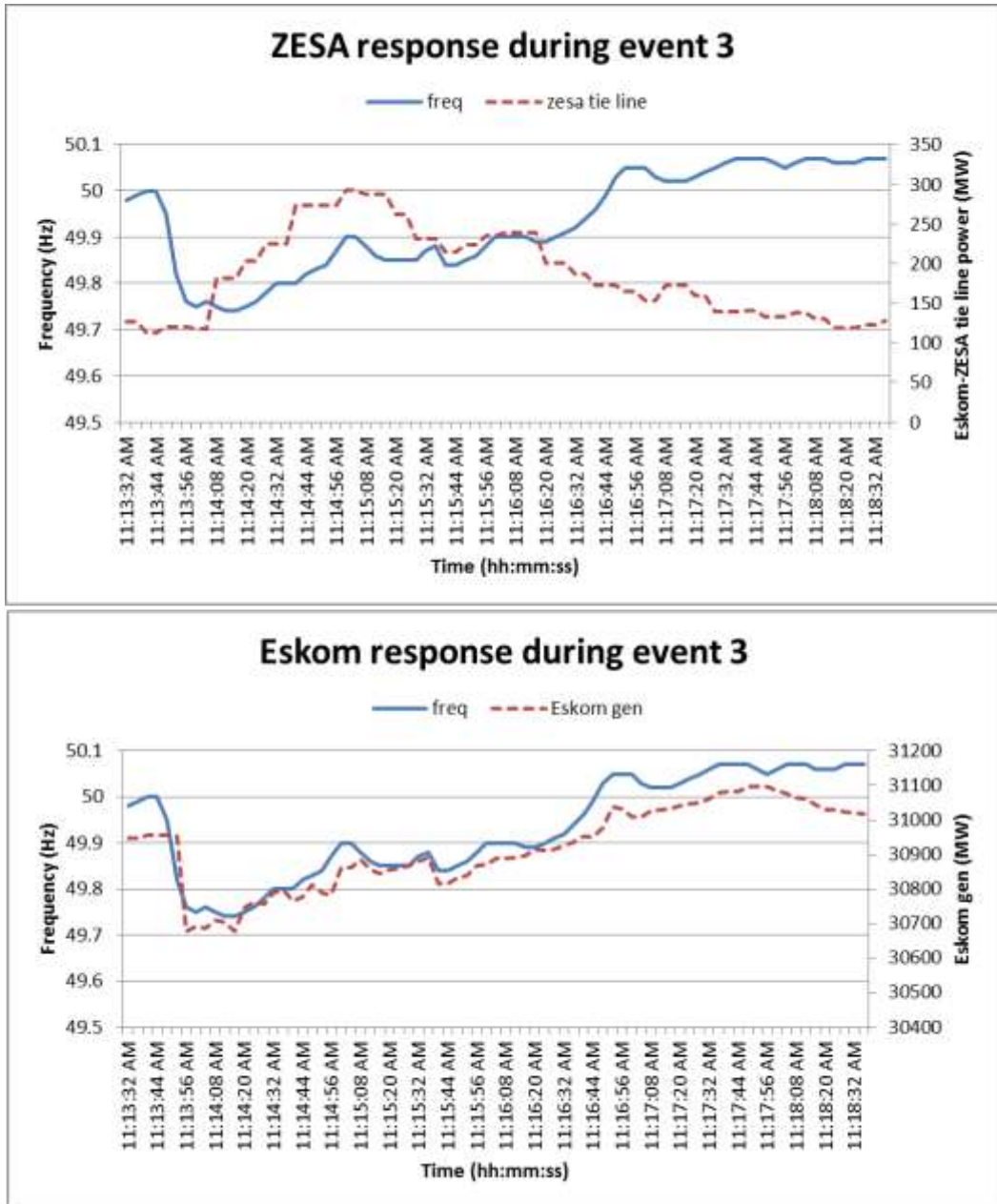

Figure 3.11 Event 3 frequency response

Pre-disturbance and maximum excursion/response values were deduced as explained in Section 3.3. Tie-line maximum response is calculated by subtracting pre-disturbance loading level from the maximum sent out loading.

Table 3.1 Eskom-ZESA frequency response analysis

Event	Lost Power (MW)	Pre-disturbance (Hz)	Max excursion (Hz)	Settling freq (Hz)	Eskom Demand Pre-disturbance (MW)	Tie-Line Pre-disturbance Power (MW)	Eskom max response (MW)	Tie-line max response (MW)
Event 1	250	49.879	49.736	49.81	31508.00	190	192	130
Event 2	351	49.858	49.725	49.81	29607.00	210	254	138
Event 3	197	49.935	49.739	49.86	30955.00	110	252	156

The measurements from SCADA show that the ZESA system contributes to the interconnected power system's frequency response. The analysis proves that governing response observed on the Eskom-ZESA tie-line when there is a loss of generation in the Eskom area cannot be deemed negligible. In fact, the frequency deviation is arrested by the combination of governing response from Eskom generation and the support from ZESA through the tie line. This is very important in validating the existing assumption as mentioned in the problem statement.

3.7 Factors influencing tie line behaviour

3.7.1 Automatic Generation Control (AGC)

AGC is a centralised control loop for system frequency control. Its input is the Area Control Error (ACE) which is calculated by considering tie line power flows and system frequency. The ACE equation is shown below.

$$ACE = (T_A - T_S) + 10\beta(F_A - F_S) \quad (3.2)$$

Where:

T_A is the tie-line actual power flow

T_S is the scheduled tie-line power flow

F_A is the actual system frequency

F_S is the scheduled/nominal system frequency

β is the control area frequency bias

AGC can operate in three different modes [11]. In each mode the ACE calculation is based on the control objective. Tie-line biased control (TLBC) mode is the default mode in the interconnected areas because it considers both the tie-line power flow error and frequency error in the ACE calculation.

Table 3.2 AGC modes and corresponding ACE

AGC Mode	ACE calculation
Tie-line biased control (TLBC)	$(T_A - T_s) + 10\beta(F_A - F_S)$
Constant frequency control (CFC)	$0 + 10\beta(F_A - F_S)$
Constant net interchange control(CNIC)	$(T_A - T_s) + 0$

Figure 3.12 shows the governing response while a generator is also on AGC. The generator was scheduled to provide instantaneous reserves (governor enabled) and regulating reserves (AGC switched on) during the hour.

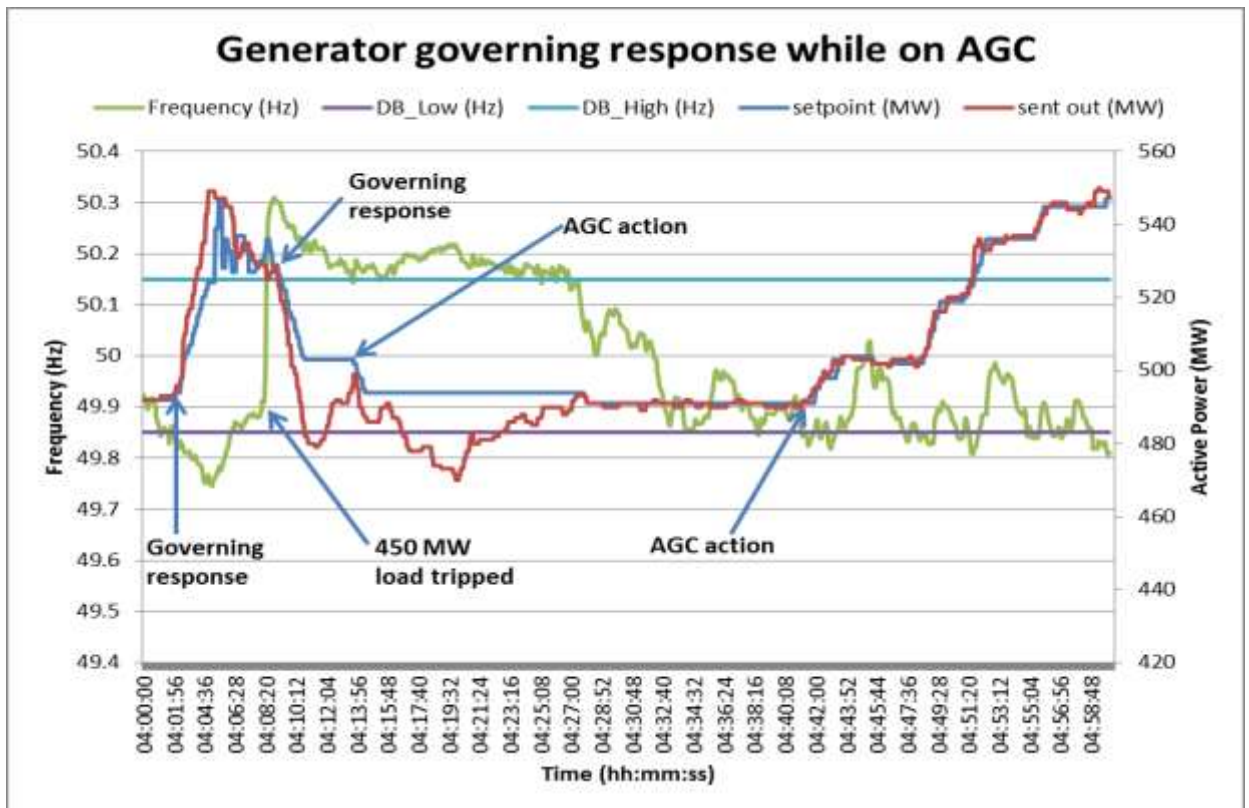

Figure 3.12 Generator unit governing response while on AGC

When the system frequency went below 49.85 Hz (DB_low), the generator (and other generators scheduled to provide instantaneous reserves) responded instantaneously to arrest the frequency decline. As a result, the system frequency recovered back to the dead band. Generator output (sent out) settled at a higher level. Immediately after that, 450 MW load tripped resulting in a frequency overshoot to above 50.15 Hz. The generator (and other generators scheduled to provide instantaneous reserves) responded instantaneously by reducing power output. This response brought system frequency back to close to 50.15 Hz. At this stage this generating unit was close to the AGC low limit; therefore, other units that were available to provide AGC capacity were used to bring the system frequency back to the dead band. When the system frequency was in the dead band the unit sent out and set point were constant. Later on when the system frequency was close to the lower dead band threshold the unit was ramped up using the AGC system.

The above discussion shows that primary frequency control (governing) is not active when the system frequency is within the dead band (49.85 Hz – 50.15

Hz); only AGC is active in this region. When the system frequency goes outside the dead band both governing and AGC are active. However, governing response is more dominant because of the droop and frequency deviation ($(1/R)\Delta f$) influence. Thus, the unit responds to governing first and later it starts responding to the AGC action. While the unit is governing the set point is adjusted accordingly as required by the TEMSE AGC control system.

In the study the interest was on governing response contribution by ZESA to the interconnected power system. Since it is evident that AGC action only starts after governing response, it was not considered in the study.

3.7.2 GMPC in Cahora Bassa

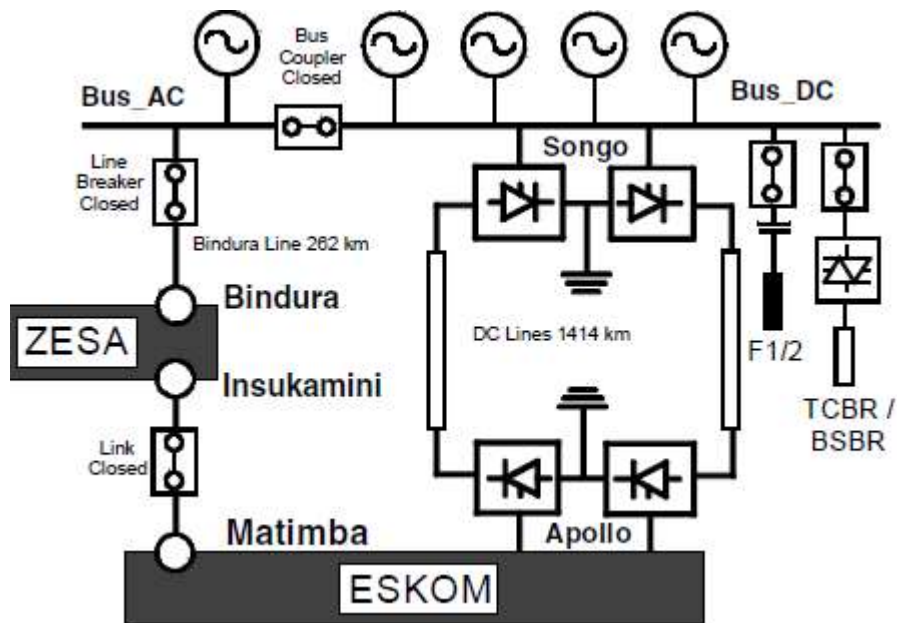

Figure 3.13 Cahora Bassa-ZESA-Eskom interconnection [12]

Above is the overview of the HCB-ZESA-Eskom system interconnection. There are 5 generators at Hydroelectric Cahora Bassa (HCB) power station; these generators feed into the dual 220 kV busbar in Songo substation. The dual busbar substation consists of an AC busbar and a DC busbar as shown in Figure 3.14 below. The HVDC is connected to the DC busbar whereas the AC busbar is normally used to supply some of the load in ZESA through the Songo-Bindura transmission line. To control power generation and its dispatch through

parallel AC and DC interconnections at HCB the Grid Master Power Controller (GMPC) is used. The GMPC is the central power controller that prescribes the power transmission orders for the HVDC and AC line while ordering appropriate generation for each busbar. All load and generation limits are respected. It maintains and controls power balance under normal and fault conditions for both interconnected and separate busbars.

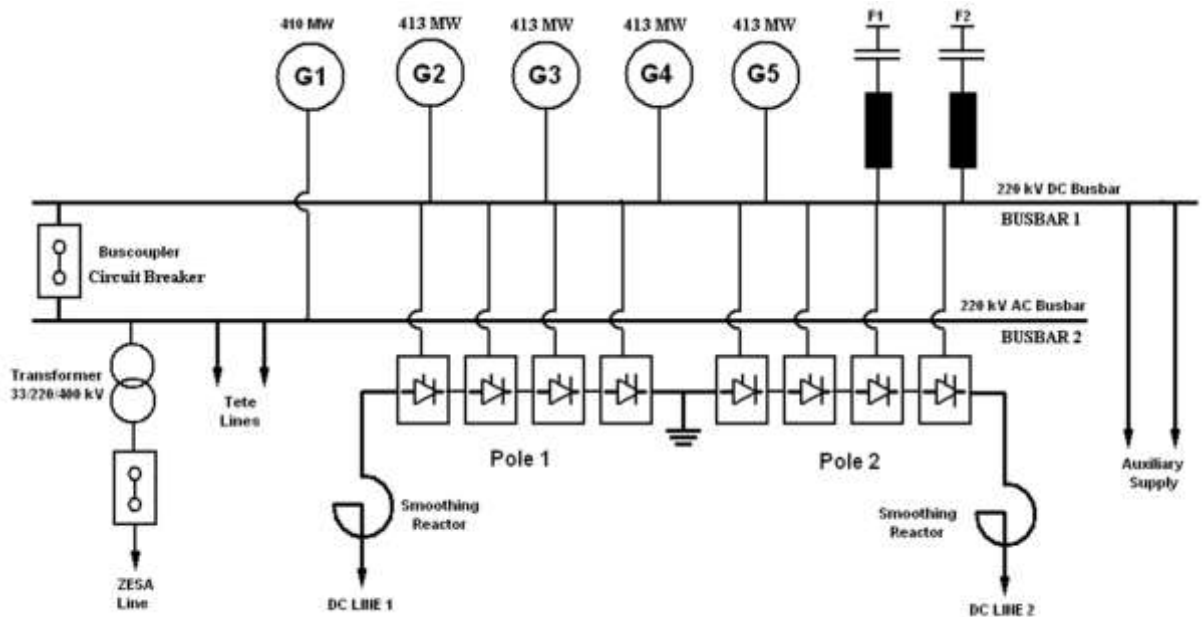

Figure 3.14 Songo substation single line diagram

Above is the single line diagram of HCB and Songo substation. The bulk of power generated in HCB flows directly to Eskom through the HVDC system, some of the power is delivered to ZESA (also connected to the Eskom AC grid) through the AC transmission line [12]. The network is normally operated with the HVDC system connected to the DC busbar and the AC line connected to the AC busbar. Normal operation is with the AC busbar and DC busbar coupled via a single bus coupler breaker. One of the advantages of operating with the bus coupler closed is full exploitation of all machines. Power flows from the bus where there is surplus power to the bus where there is power deficit. GMPC has bus coupler protection functionality. The bus coupler protection operation results in AC and DC system split. AC and DC system splitting is usually required for severe disturbances or when the AC filters trip. The AC system must be protected against harmful harmonic voltages or currents generated by

the HVDC which may be amplified by network resonance. GMPC bus coupler protection settings are as following.

Bus Coupler Protection in GMPC (related to frequency):

Time delay :

If $49,2 \text{ Hz} < f < 49,6 \text{ Hz}$ for continuous $t \geq 18 \text{ sec}$

(Δ Hysteresis = 0,05 Hz for 49,6 Hz) - Underfrequency

If $50,4 \text{ Hz} < f < 50,8 \text{ Hz}$ for continuous $t \geq 18 \text{ sec}$

(Δ Hysteresis = 0,05 Hz for 50,4 Hz) – Overfrequency

The settings are such that when the system frequency is below 49.6 Hz but above 49.2 Hz for more than 18 seconds continuously the bus coupler protection will operate; this is for under frequencies. For over frequencies, the settings are such that when the system frequency is above 50.4 Hz but below 50.8 Hz for more than 18 seconds continuously the bus coupler protection will operate.

Instantaneous (200 msec.s delay):

If $f \leq 49,2 \text{ Hz}$ (Δ Hysteresis = 0,05 Hz) - Underfrequency

If $f \geq 50,8 \text{ Hz}$ (Δ Hysteresis = 0,05 Hz) – Overfrequency

For extreme frequency deviation the bus coupler protection operates instantaneously as per above settings.

Power coordination in the GMPC

It is important to understand that the GMPC has the power order coordination feature. This feature coordinates generation with the combined HVDC and Bundira line orders/contracts. The GMPC gives precedence to the AC loads. Therefore, the HVDC load is not supplied until all AC loads have been satisfied by generation. When the generator that was supplying AC loads trips, its contribution to the AC load is immediately subtracted from the HVDC contract.

GMPC operation modes

According to [12], GMPC has three modes of operation:

- Isolated operation in frequency control mode
- Coupled operation in ZESA control mode
- Coupled operation in angle control mode

Isolated operation mode is applicable when the bus coupler in Figure 3.14 is open. In this mode, the GMPC controls the turbines on the AC bus to provide constant power to ZESA [12]. On the DC bus the GMPC maintains the exact power balance at 50 Hz by modulating the HVDC output around its base power order depending on the frequency error [12]. Coupled operation in ZESA control mode is applicable when the bus coupler is closed but Eskom-ZESA link opened. In this mode, the GMPC supplies constant power to ZESA [12]. The third mode is coupled operation in angle control mode; this mode is applicable when bus coupler is closed and Eskom-ZESA link closed. According to [12] the HVDC is operated in constant power mode in coupled operation. This is achieved by modulating HVDC power as a function of the derivative of the Cahora-Bassa/Apollo voltage and the derivative of the Bundira power.

Different control strategies are implemented for different modes of operation. The GMPC has a wide range of features; these are discussed in [12].

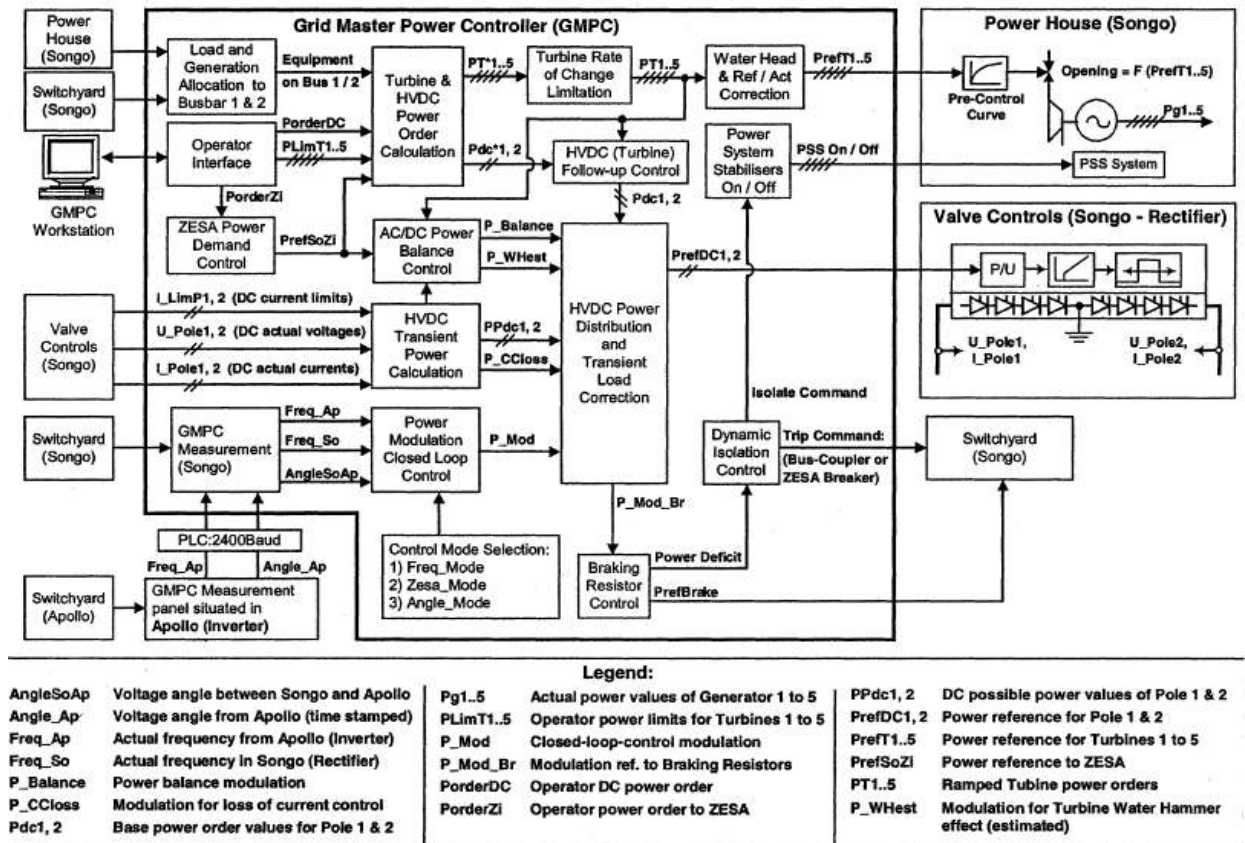

Figure 3.15 GMPC software overview [12].

GMPC has automatic selection of control mode which is essential for realizing robust and safe controls for parallel AC/DC operation. The control mode selection is based on evaluation of the rate of change of angle and is therefore independent of status signals from remote links [12].

To model bus coupler's behavior during the disturbances the following must be understood:

- GMPC fundamentals
- All conditions required to trigger bus coupler operation
- GMPC automatic mode selection
- Control strategies used in different GMPC modes

Modelling the bus coupler was going to increase the scope of the study and additional time was going to be required. As a result the study was limited to ZESA governing response during typical (small) system frequency disturbances (bus coupler closed and GMPC coupled operation mode). Severe disturbances that may lead to AC and DC system split at Songo were not considered. The

GMPC was not modelled. The assumption is that GMPC action is embedded in the Eskom-ZESA tie-line response for small frequency disturbances.

3.7.3 HVDC typical response to frequency deviations

The HVDC behaviour during the frequency disturbances is influenced by the GMPC as explained in the preceding section. The GMPC has to satisfy the constant power contractual requirement on the Bindura line; hence the AC loads take priority in GMPC power coordination. During small system frequency disturbances, the HVDC power flow is not expected to change. Unless the frequency disturbance affected the power supply to Bundira line (i.e. generator trip in Cahora Bassa).

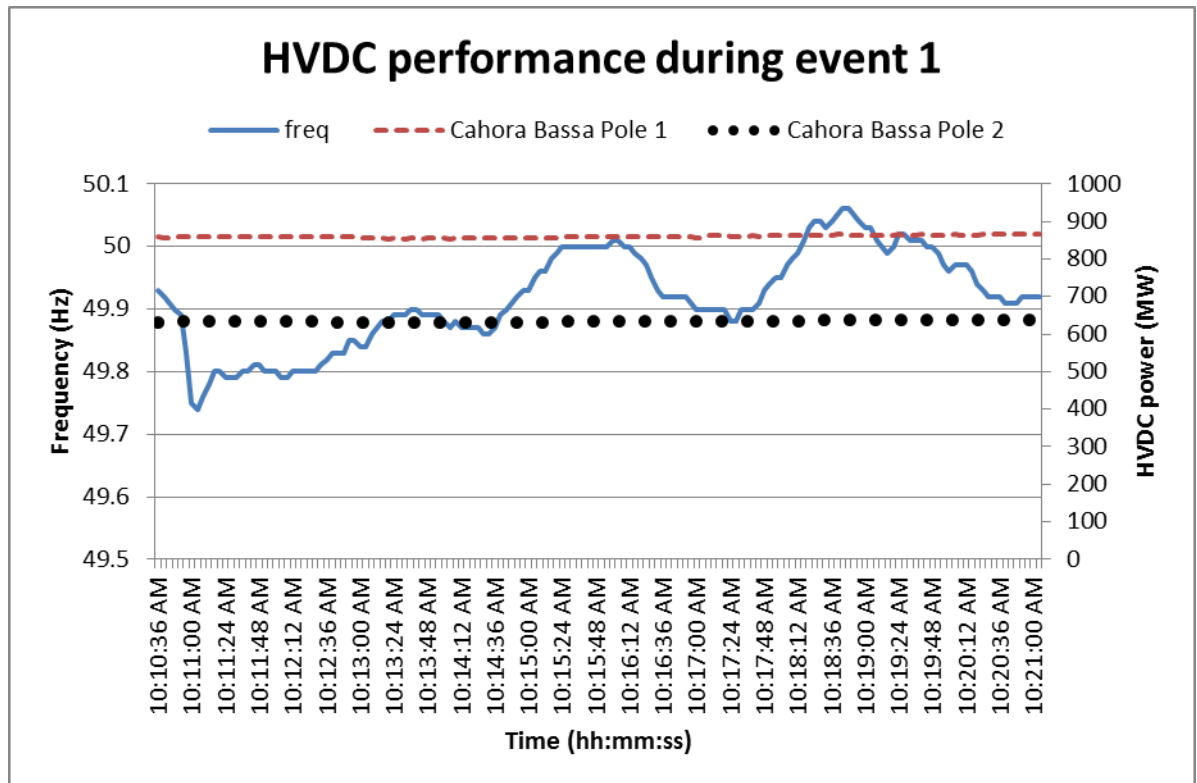

Figure 3.16 HVDC performance during event 1

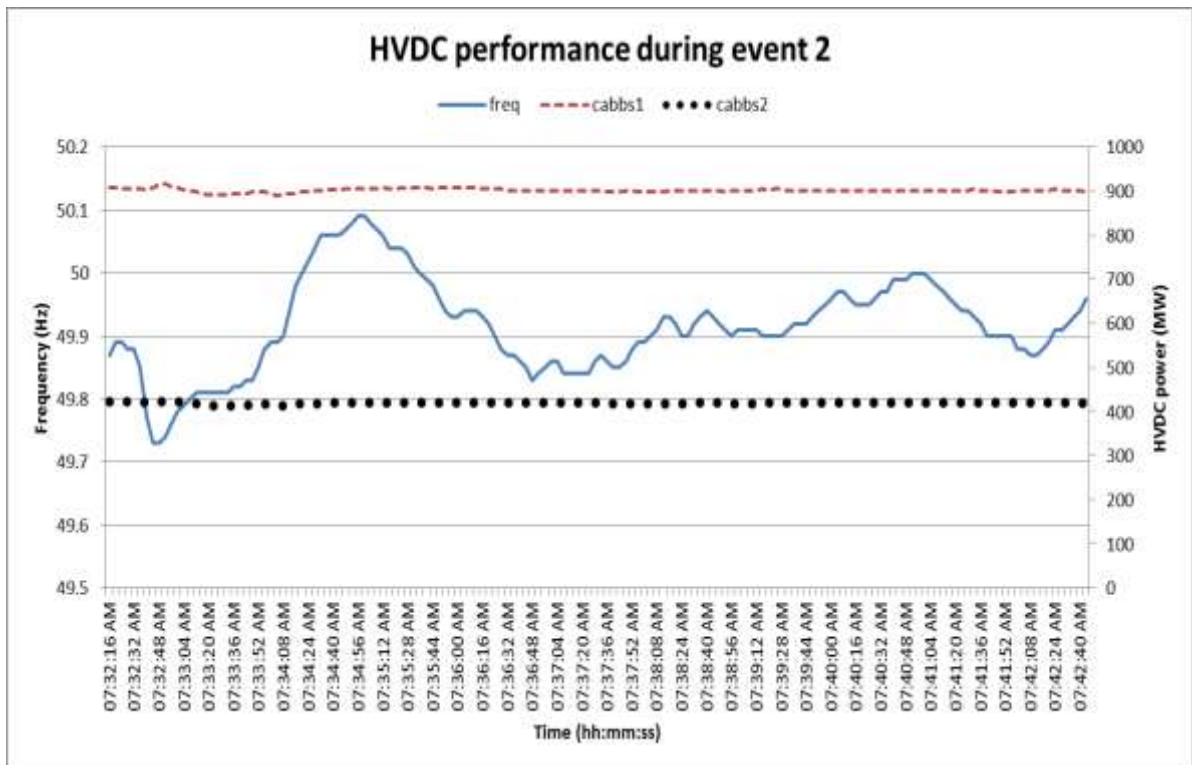

Figure 3.17 HVDC performance during event 2

Event 1 and event 2 were due to loss of generation in the Eskom area. The lost generation had little or no impact on the Bindura line power flow; as a result, the HVDC power flow remained constant as shown in Figure 3.16 and Figure 3.17.

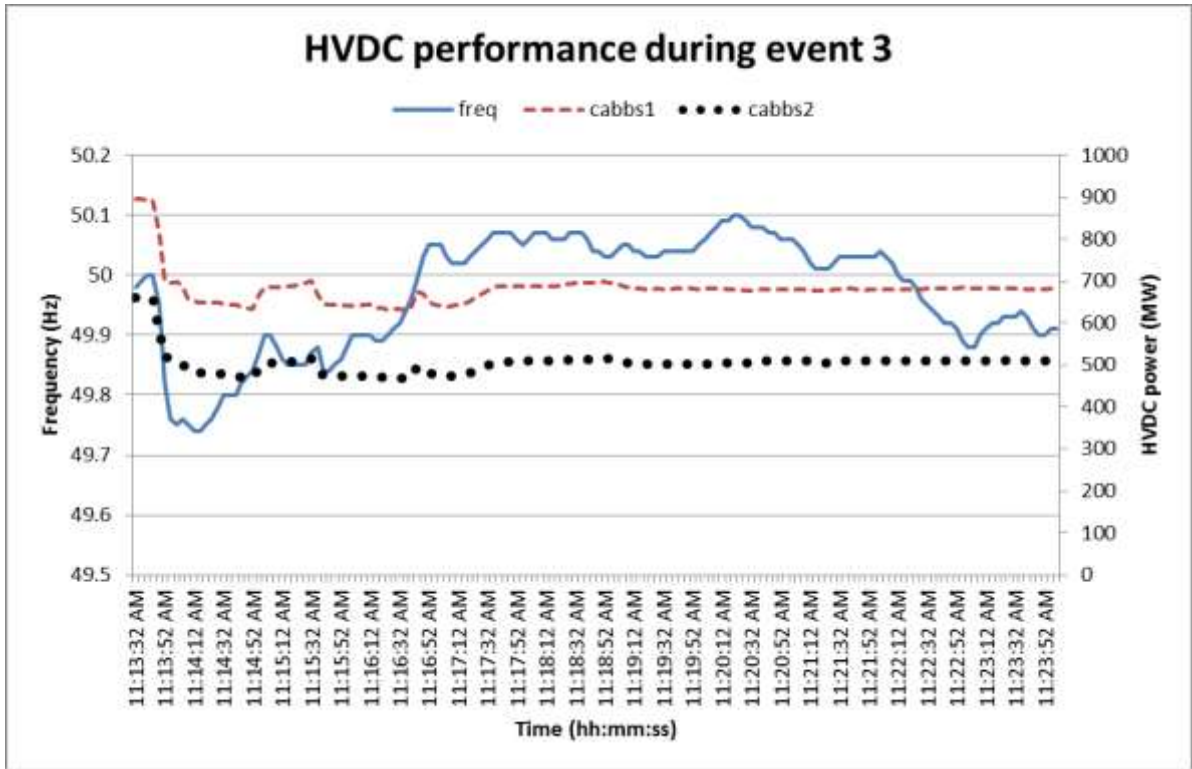

Figure 3.18 HVDC performance during event 3

Event 3 was due to the generator trip at Songo. According to the Eskom morning report, generator 3 at Songo tripped due to an earth fault. Based on the HVDC response, one can conclude that the generator trip at Songo reduced the power supply to the Bindura line. Hence the GMPC reduced the HVDC power to maintain constant power on the Bendura line. This is in line with the GMPC power coordination feature discussed in [12].

CHAPTER 4. MODEL DEVELOPMENT AND VERIFICATION

4.1 Introduction

Tie-line behaviour during small system frequency disturbances has been evaluated in Section 3.6. The aim of this section is to develop a model that will mimic tie-line governing behaviour. The standard plant model frame structure shown below was adopted. As seen on the diagram; the frame consists of generator block, power system stabilizer (PSS), automatic voltage regulator (AVR), excitation system and governor. Standard models for these systems already exist in simulation packages like DlgSILENT PowerFactory.

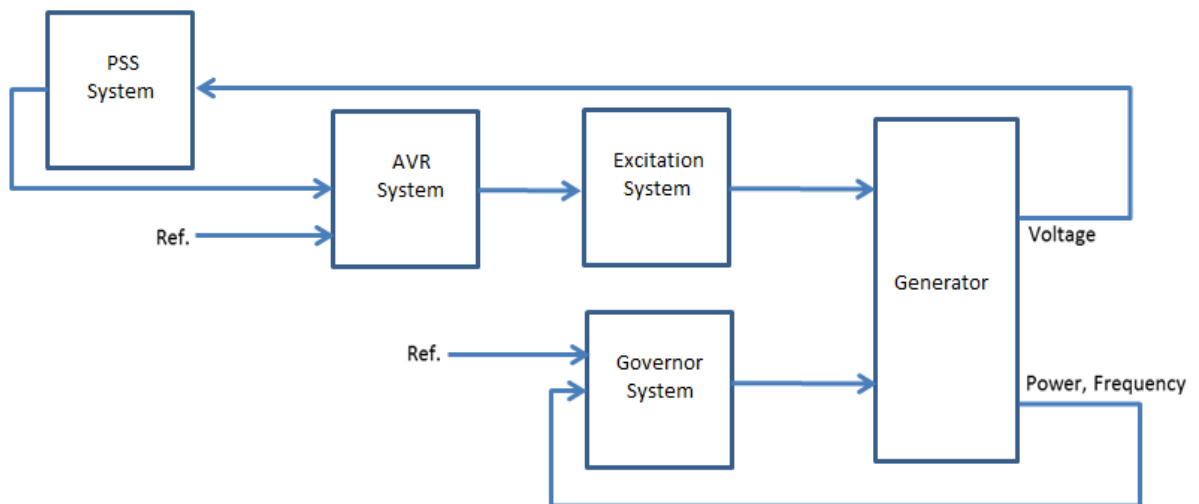

Figure 4.1 Plant model frame structure

The frame was created in DlgSILENT PowerFactory, all relevant systems for frequency studies depicted on the above diagram were included.

4.2 Plant model frame components

4.2.1 Governor system

The fundamental function of a governor system is to control speed or load of the generator. The primary frequency (speed) control function involves feeding back the speed error to control the governor valve position. In order to ensure satisfactory and stable parallel operation of multiple units, the speed governor is provided with a droop characteristic [2].

The modelling of the turbine governor is of greatest importance when studying frequency control and stability [13]. The studies in this project deal primarily with primary frequency control. With this understanding in mind, the modelling of the turbine governor is particularly important. A typical mechanical-hydraulic speed governing system consists of a speed governor, a speed relay, a hydraulic servomotor and governor controlled valves which are functionally related as shown in the Figure 4.2 [13].

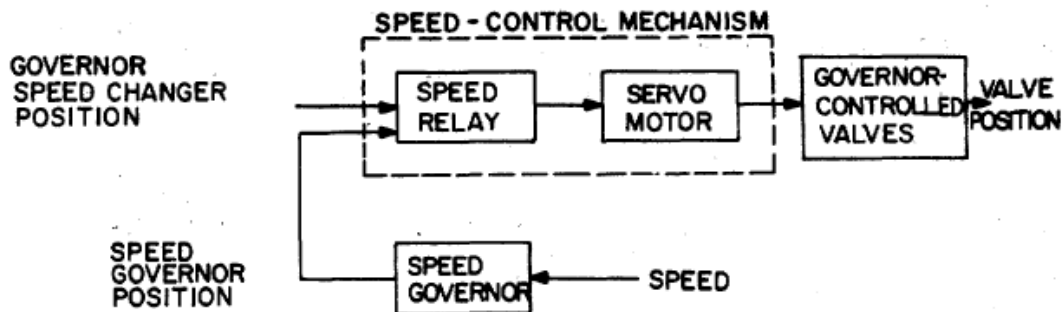

Figure 4.2 Mechanical-Hydraulic Speed governing system for steam turbine functional block diagram [13].

The simplest steam turbine speed governor model is TGOV1. This model represents droop characteristic (R), main steam control valve motion and limits (T_1 , V_{MAX} , V_{MIN}). It also has a single lead-lag block representing time constants associated with the motion of the steam through the re-heater and turbine stages.

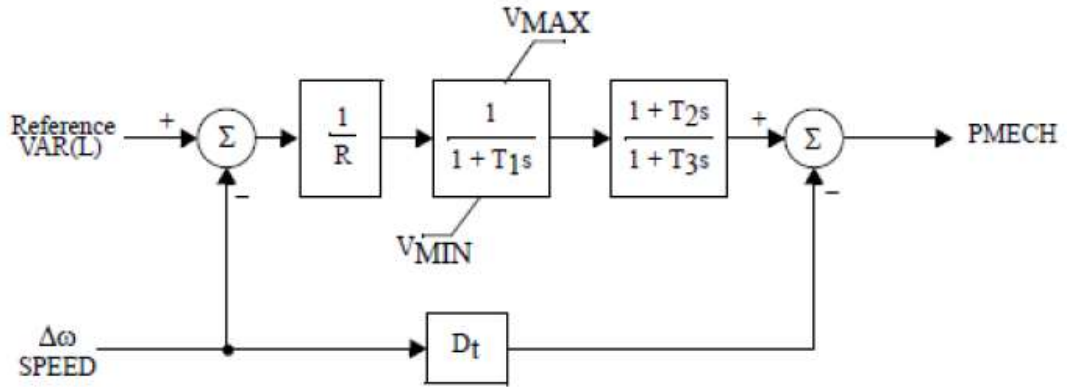

Figure 4.3 TGOV1 steam turbine model [14]

A model that is slightly more detailed than TGOV1 is the IEESG0 model. In this model droop is represented by K_1 which is equivalent to $1/R$ in the TGOV1 model, two turbine fractions are introduced (K_2 and K_3) to represent different stages in the steam turbine [14].

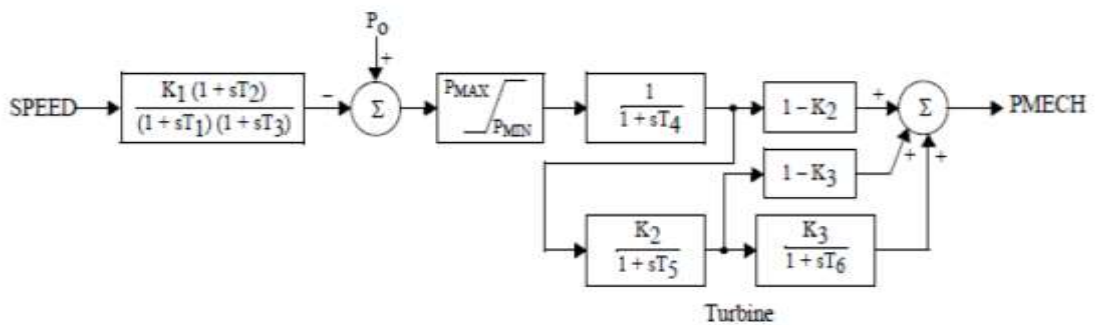

Figure 4.4 IEESG0 steam turbine model [14]

IEEEG1 is the next level model of a steam turbine and the one recommended for use [14]. It includes the rate limits on the main control valve (U_0 and U_C), four steam-stages and the ability to cross compound units.

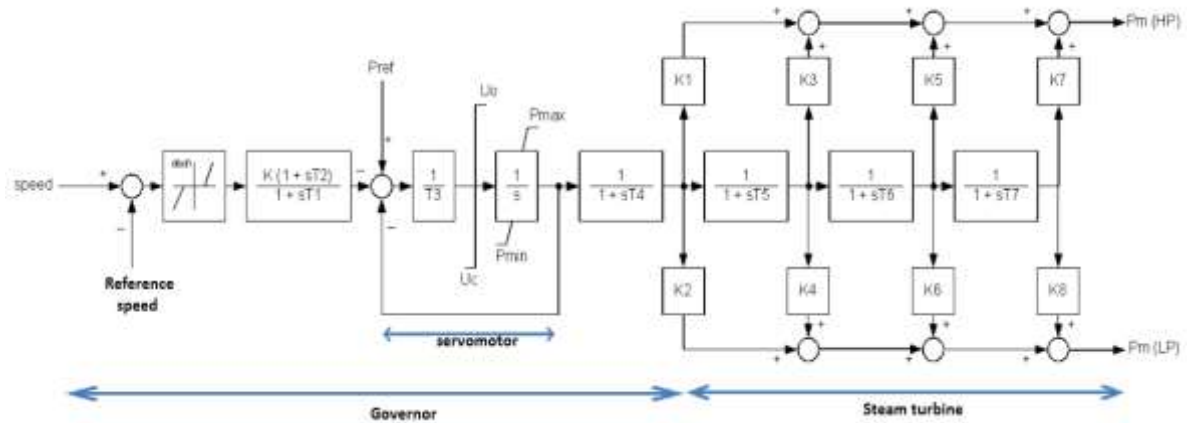

Figure 4.5 IEEE1 model

All of the models described above assume constant steam pressure and temperature. Parameter description is shown in the Appendix. These models come with default parameters which have to be tuned to achieve the desired performance.

A more detailed steam turbine and boiler system model is represented in the TGOV5 model. This model goes even deeper into actual control behaviour and turbine dynamics. TGOV5 is presently available in some commercial software tools such as DigSILENT PowerFactory. The turbine and droop control model in TGOV5 is identical to the IEEE1 model. The additional features in TGOV5 are:

- Added boiler dynamics
- Coordinated controls acting on current electrical power and pressure error
- Emulation of the drum pressure controller and fuel dynamics

The TGOV5 model is very complex. Models of such complexity are rarely used or appropriate for large scale power system simulations [14].

4.2.2 Power system stabilizer (PSS)

The PSS is widely used for improving the damping effect in the frequency range of the electromechanical modes of rotor oscillations. If the PSS is tuned

properly, it compensates for negative damping associated with the turbine-governor and high gain automatic voltage regulators [14]. A standard power system stabilizer available in the simulation package was added to the plant model frame to provide stability. This PSS was not tuned for small signal stability because the study was focussed on primary frequency control.

4.2.3 AVR and Excitation

The exciter provides dc power to the synchronous machine field winding. The AVR compares the generator terminal voltage with the reference voltage which represents the desired terminal voltage. It provides load compensation needed to hold the generator terminal voltage at a constant voltage when required. This functionality is important during frequency control studies. As a result, the standard AVR available in the simulation package was added to the plant model frame.

4.3 Grid used to tune the generator model

The Eskom network behaviour is well understood and a detail model exists in a simulation package (DIgSILENT PowerFactory). The objective of this project was to tune a generator to mimic the tie-line behaviour during frequency disturbances. Therefore the grid set up was such that ZESA is represented by a single generator and Eskom was represented by the external grid. The two are connected by the transmission line as shown in the diagram below.

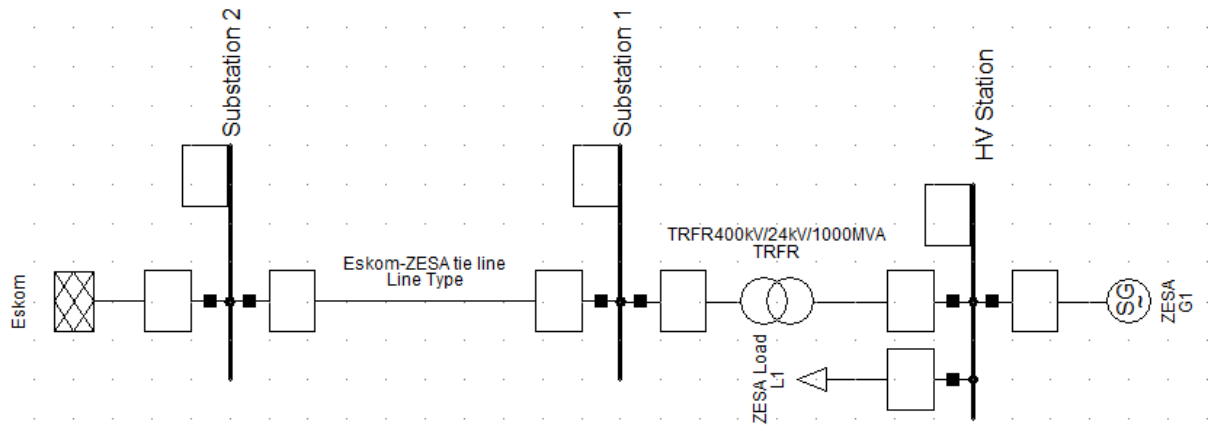

Figure 4.6 Grid used to tune generator to the mimic tie-line behaviour

As explained in the previous section, the standard plant model frame structure was adopted for generator representation. Relevant blocks were added and the model was run for 1 minute without disturbance to ensure that it is stable. Results are shown in Figure 4.7.

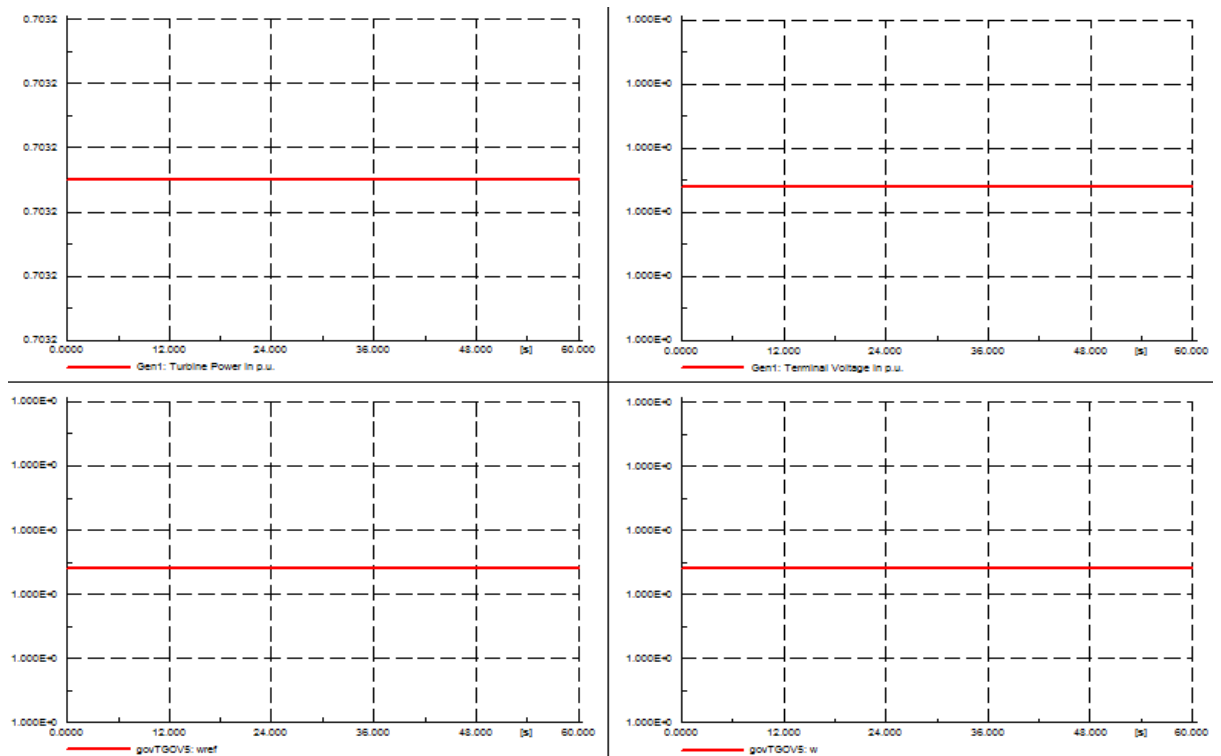

Figure 4.7 Steady state simulation run

The steady state simulation run shows that the models are stable.

4.4 Editing frame for tuning purposes

The standard plant model frame is shown in Figure 4.1. The input signals to the governor are active power and frequency. The output signal is the turbine power. To tune the governor such that the generator exhibits the required behaviour the frame was edited. This was done so that the measured frequency is the input to the governor instead of the generator speed which is normally feedback from the generator output. The modified plant model frame is shown in Figure 4.8.

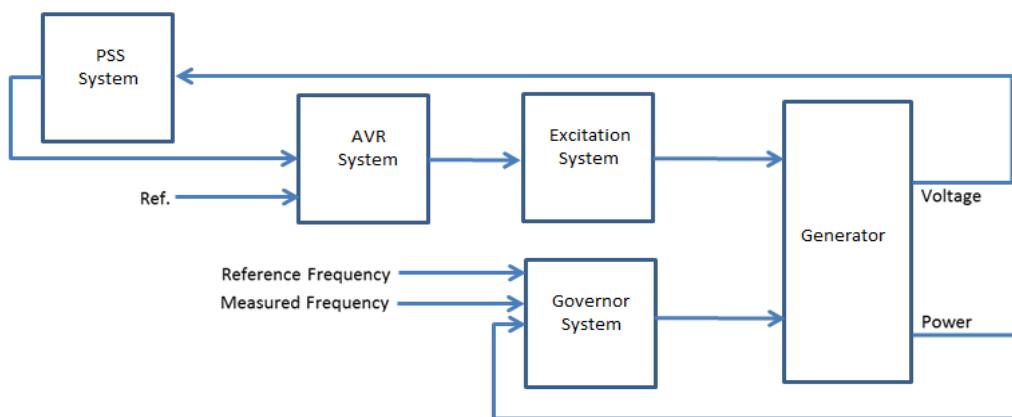

Figure 4.8 Edited plant model frame structure

The edited plant frame makes it possible to inject frequency measurements to the governor model and then tune the governor parameters to achieve the desired generator output power.

4.5 Generator governor tuning strategy

The approach adopted for tuning the generator governor system is very simple and straight forward. Typical Eskom generator parameters were used in a generator model. During the governor tuning exercise the generator parameters are not changed. Only the governor parameters are tuned. The governor system is excited using frequency measurements. The Eskom-ZESA tie-line power flow profile for the specific event, which is the set of available measurements, is compared to the simulated output of the generator. When the generator output does not following the measured Eskom-ZESA tie-line power

flow profile. The relevant governor parameters are tuned. This is an iterative exercise which is done until the simulated output is close to the measurements.

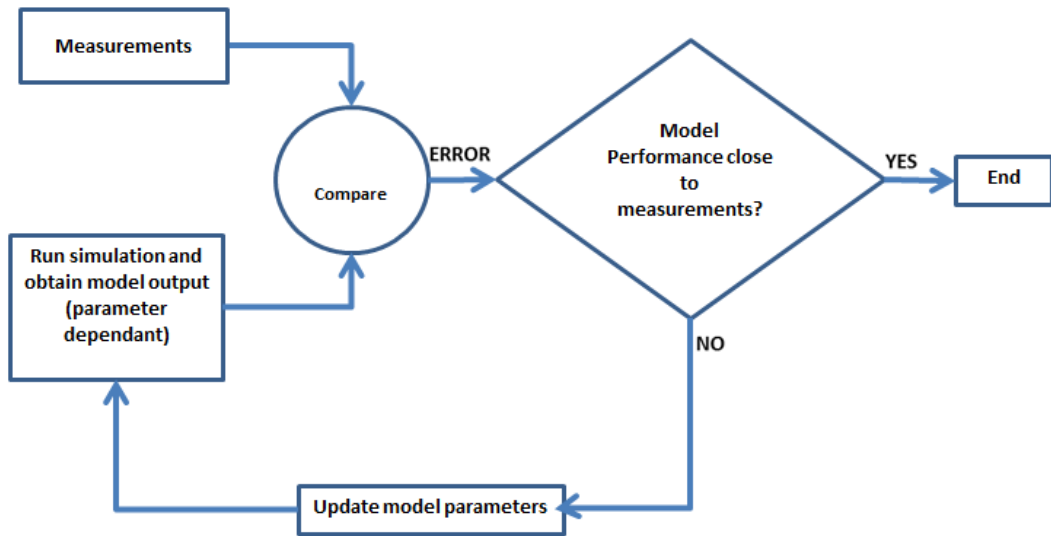

Figure 4.9 Block diagram of model tuning

4.6 Simulation results

The system disturbances that can be used as a good representation of the interconnected power system's response to frequency deviations were identified and analysed in Section 3.6. Event 1 and event 2 (from Section 3.6.2) were used as an example to show how the developed model performs against real system disturbances. For these particular events, the frequency measurements and tie-line power flow data were retrieved from the SCADA historical information database. The frequency profile was injected into the generator's governor system. The governor parameters were tuned such that the generator output matches the tie-line power flow behaviour. Two different types of governor models were used; firstly the IEEE1 governor was tuned to control generator output to match tie-line performance and then the TGOV5 governor model was used. Simulation results are shown in Figure 4.10.

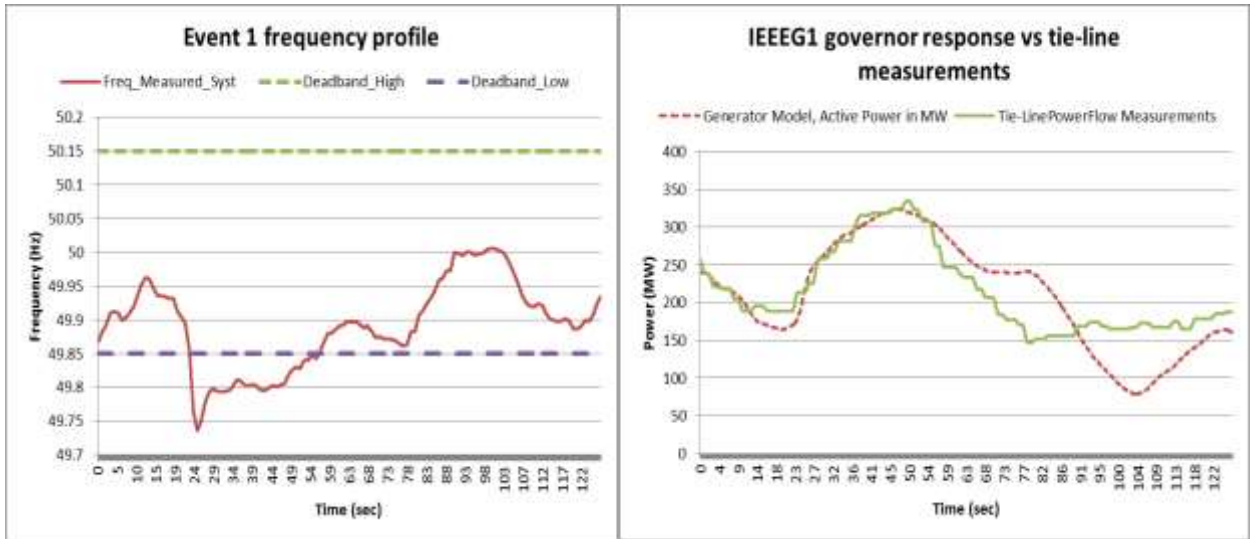

Figure 4.10 Event 1 IEEEG1 governor model simulation result

The IEEEG1 governor model is a simplified governor representation. As a result, it is not easy to tune parameters to match tie-line response. However, the performance is acceptable and it can be used to represent the tie-line governor response.

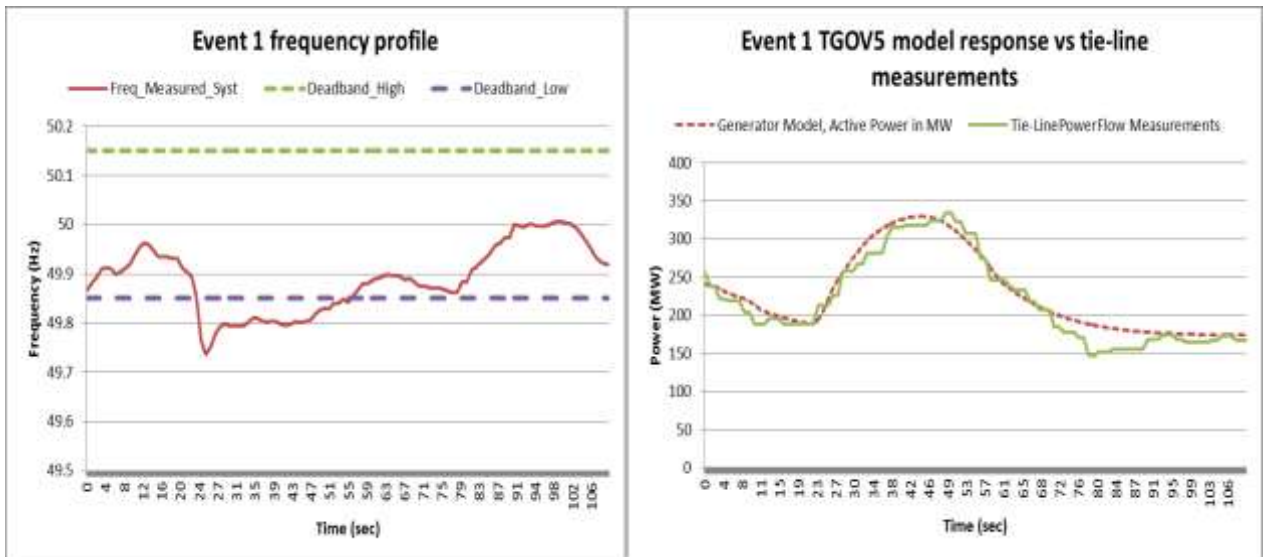

Figure 4.11 Event 1 TGOV5 governor model (without frequency dead band) simulation results

The TGOV5 governor model is very complex as discussed in Section 4.2. The model includes boiler dynamics, and this improves performance such that it is

possible to tune the parameters to follow the tie-line performance as close as necessary. Since it was clear that the TGOV5 model performed better than the IEEEG1 model in event 1, in event 2 the IEEEG1 governor was not used.

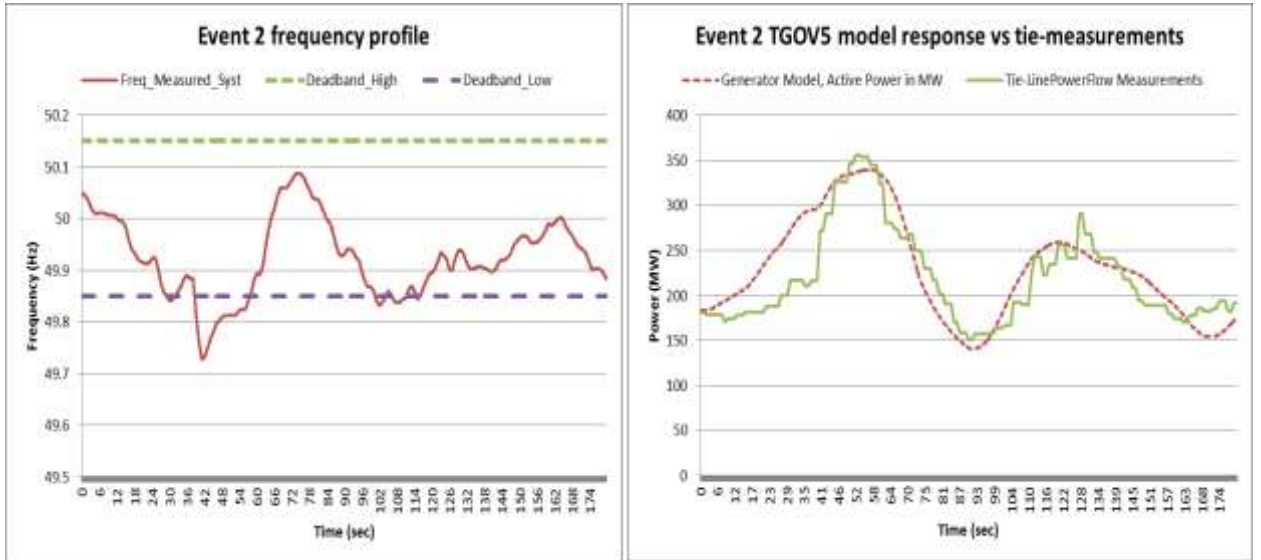

Figure 4.12 Event 2 TGOV5 governor model (without frequency dead band) simulation

In event 2, the system frequency gradually declined from 50 Hz to the lower dead band limit. The governor model without the frequency dead band as specified in [15] starts responding immediately the frequency deviation is detected. The frequency dead band was introduced in the TGOV5 model and the governor parameters were tuned to achieve the required performance. The simulation results are shown in Figure 4.13 and Figure 4.14 below.

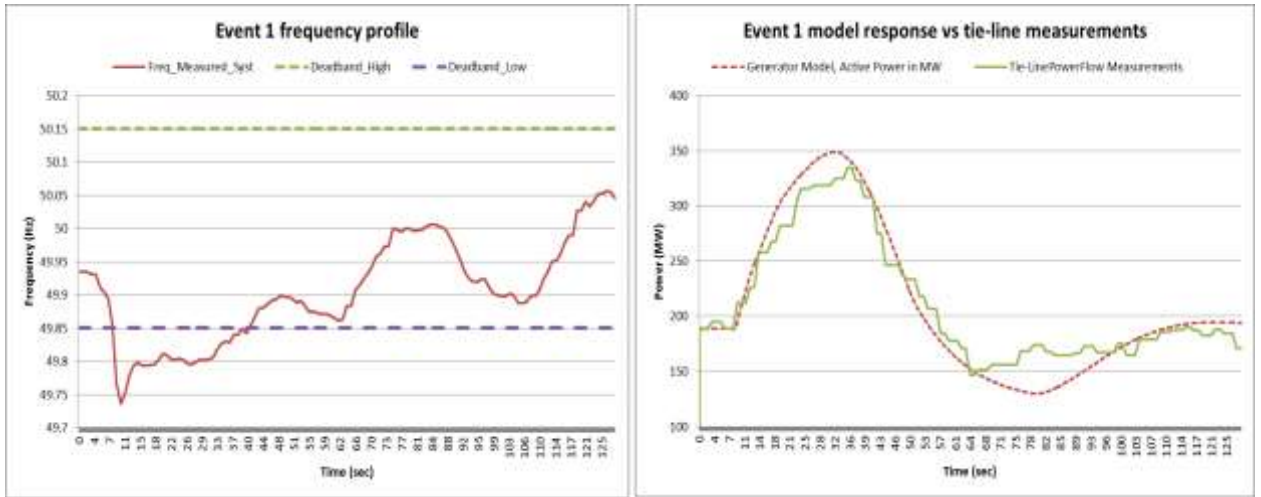

Figure 4.13 Event 1 TGOV5 governor model (with frequency dead band) simulation results

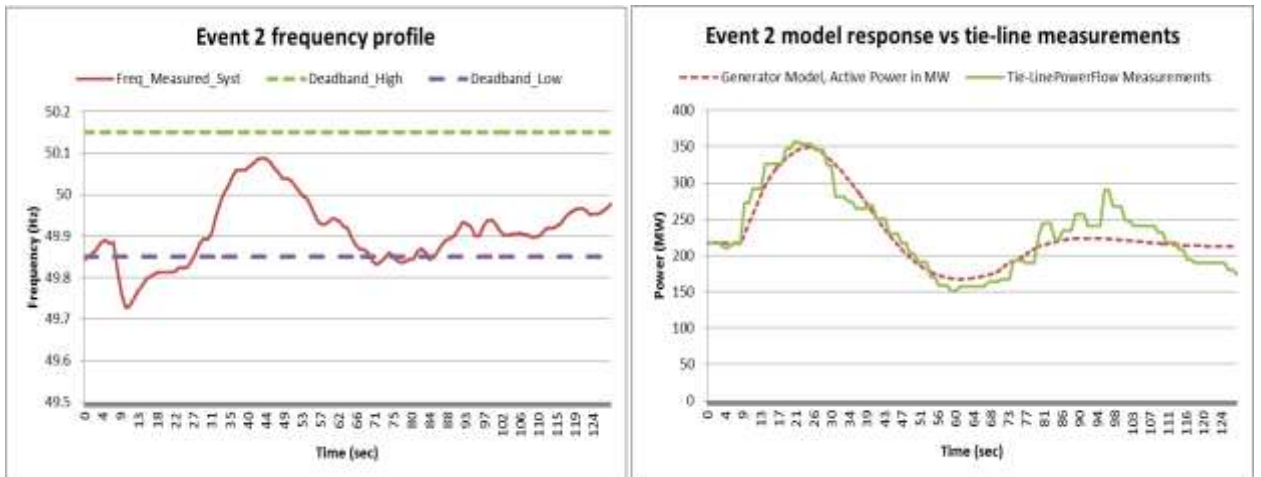

Figure 4.14 Event 2 TGOV5 governor model (with frequency dead band) simulation results

4.7 Summary of the results

In summary, system performance was analysed using Energy Management System (EMS) historical data. The analysis proves that governing response observed on the Eskom-ZESA tie-line when there is a loss of generation in the Eskom area cannot be deemed negligible. In fact, the frequency deviation is arrested by the combination of governing response from the Eskom generation and the support from ZESA through the tie-line.

The generator model that mimics the tie-line behaviour during frequency disturbances was developed and tested using real system disturbance data. The TGOV5 model is capable of replicating system performance, whereas the IEEE1 model is very simplified and not easy to tune to achieve real system performance. The existing assumption was validated and the system model was developed as per the study objectives. The research questions were addressed during the course of the study. Details are discussed in the following chapter.

CHAPTER 5. CONCLUSIONS & RECOMMENDATIONS

5.1 Introduction

This section of the document presents conclusions made from the study, describes how research questions were answered, presents recommendations and presents suggestions on further research work.

5.2 Conclusions from the study

The main objectives of the study were to quantify the Eskom-ZESA tie-line's contribution to primary frequency control during system frequency disturbances and develop a generator model to represent the tie-line behaviour. To achieve the first objective, background study on frequency control, interconnected systems and two area systems was performed. After understanding the fundamental theory, the system behaviour was studied. This resulted in calculating ZESA response to frequency disturbances to validate the existing assumption.

The governing response through the Eskom-ZESA tie-line was analysed thoroughly and the results show that there is significant support from ZESA during system frequency disturbances. This proves that the existing assumption is not valid anymore. The generator model that represents the tie-line's behaviour during system frequency disturbances was developed.

5.3 Research questions

At commencement of the study it was highlighted that to validate the existing assumption the following research questions were to be considered:

1. What dynamic behaviour must be examined in the proposed study?

2. What factors influence the specific Eskom-ZESA interconnection dynamic behaviour?
3. What improvements can be made to the way the Eskom-ZESA interconnection is presently operated?

These questions were addressed during the course of the study.

5.3.1 *What dynamic behaviour must be examined in the proposed study?*

To address this question the tie-line behaviour was studied and understood. What came out of the study is that the tie-line can import or export power to or from the Eskom area. Since one of the objectives of the study was to quantify ZESA's contribution to governing response during system frequency disturbances, the interest is on the tie-line behaviour when Eskom is importing power. Section 3.5 describes three things that can happen when there is a loss of generation in Eskom while the tie-line is importing power:

1. Tie-line trip
2. Governing
3. Tie-line power flow direction reversal from import (to Eskom) to export

The dynamic behaviour that must be examined in the study was governing response while the tie-line is exporting power from ZESA to Eskom. This leads to conclusions as to whether the current assumption is valid or not.

5.3.2 *What factors influence the specific Eskom-ZESA interconnection dynamic behaviour?*

Section 3.1 and 3.2 of the report outline the South African Grid Code and Southern African Power Pool Operating Guidelines requirements respectively. These requirements have significant influence on the Eskom-ZESA interconnection dynamic behaviour. Firstly, there is a frequency dead band of ± 0.15 Hz for units providing instantaneous reserves and ± 0.5 Hz dead band for units not providing instantaneous reserves. Governing response is not expected within the frequency dead band. Secondly, there is a droop setting requirement

of 4 % for all units providing instantaneous reserves and 10 % for units not equipped with frequency dead band.

Section 3.7 of the report explains how Automatic Generation Control and Grid Master Power Controller (in HCB) can influence the Eskom-ZESA interconnected power system dynamic behaviour.

5.3.3 *What improvements can be made to the way the Eskom-ZESA interconnection is presently operated?*

The answer to this research question can be derived from the recommendations. Section 3.6 of the report shows the analysis of the tie-line response during frequency disturbances. It is clear that ZESA's contribution to the interconnected power system governing response is significant. The improvement that can be made is to consider procuring Instantaneous Reserves from the neighbouring utility to meet power system requirements, especially when the utility is experiencing extreme capacity constraints.

5.4 Recommendations

It is recommended that ZESA's governing response be considered when calculating Instantaneous Reserves requirements in Eskom since the existing assumption is not valid.

South Africa is experiencing extreme capacity constraints and as a result is linked to the diminishing operating reserves availability. Therefore it is recommended that Eskom explore the possibilities of procuring reserves as ancillary services from the neighbouring utilities to meet power system requirements since it has been proven that ZESA can provide significant governing response during system disturbances.

5.5 Suggestions for further research

Possible further research is:

1. Develop a detailed power system model of all Southern African Power Pool (SAPP) utilities and tune each generator governor model to represent SAPP primary frequency control performance.
2. Develop HCB-Apollo HVDC model that can be used for SAPP power system studies.
3. Develop Automatic Generation Control (AGC) model and perform a study to investigate both power system primary and secondary control during frequency disturbances.
4. Investigate consequences attached to selling or buying ancillary services from the neighbouring utilities within SAPP.

REFERENCES

- [1] EPRI Power System Dynamics Tutorial, *Frequency Control Draft*, March 2002
- [2] P. Kundur; *Power System Stability and Control*; Fifth reprint, New Delhi, Tata McGraw Hill, 2008.
- [3] RSA Grid Code Secretariat, *The South African Grid Code - System Operation Code*, Version 9.0, July 2014
- [4] K.P. Singh Parmar, S. Majhi, D.P. Kothari; *Improvement of Dynamic Performance of LFC of the Two Area Power System: An Analysis using MATLAB*; International Journal of Computer Applications (0975-8887), Volume 40- No.10, February 2012.
- [5] M. Mohadjer, N. Kheir; *Robustness and tie line stiffness in a multi-area interconnected power system*; American Control Conference, 1988.
- [6] O. Elgerd, C.E. Fosha; *Optimum Megawatt-Frequency Control of Multi Area Electric Energy Systems*; Power Apparatus and Systems, IEEE Transactions on, 1970, Page(s): 556-563.
- [7] D.D. Rasolomampionona; *A Modified Power System Model for AGC Analysis*; IEEE Bucharest Power Tech Conference, June 28th – July 2nd, 2009
- [8] B. Venkata Prasanth, S.V. Jayara, Kumar; *Load frequency control for a two area interconnected power system using robust genetic algorithm controller*; Journal of Theoretical and Applied Information Technology, 2005 – 2008
- [9] *SAPP Operating guidelines*, Revision 1.0 , 29 June 2012
- [10] North American Electric Reliability Corporation, “ *Balancing and frequency control – A Technical Document Prepared by the NERC Resources Subcommittee*”, January 26, 2011
- [11] M. Kurup, M. Ntusi, M. Gumede; *Tuning automatic generation control of the Eskom power system*; Cigre Joint Colloquium of study committees C1, C2 and C5; Somerset West, October 2013
- [12] P.V. Goosen, P. Riedel, J.W. Strauss; *GMPC Enables Energy Transmission over Interconnected SAPP Grid*, IEEE Transactions on Power Delivery, Volume: 18, Issue: 3, Year: 2003

- [13]IEEE Committee Report; *Dynamic Models for Steam and Hydroturbine in Power System Studies*; Trans IEEE, PAS-92, pp. 1904 – 1915, 1973
- [14]Power System Dynamic Performance Committee; *Dynamic Models for Turbine-Governors in Power System Studies*; Technical Report PES-TR1, IEEE Power & Energy Society, January 2013
- [15]RSA Grid Code Secretariat; *The South African Grid Code - The Network Code*, Version 9.0, July 2014.
- [16]T. Kennedy, S.M. Hoyt, C.F. Abell; *Variable non-linear tie-line frequency bias for interconnected systems control*, IEEE Transactions on Power Systems, Vol. 3, No. 3, August 1988.
- [17]NRS 048-9:2010 “*Electricity Supply – Quality Of Supply Part 9: Load reduction practices, system restoration practices, and critical load and essential load requirements under system emergencies*”, 2010.
- [18]H.B. Ruud, S.B. Farnham; *A New Automatic Load Control for Turbine Generators*; American Institute of Electrical Engineers, Volume: 68, Issue: 2, Year: 1949.

APPENDIX A: LITERATURE REVIEW AND THEORETICAL BACKGROUND

A1 Frequency control background discussion

A1.1 Inertia

The basic concept of primary frequency control (speed governing) is best illustrated by considering an isolated generating unit supplying a local load as shown in the diagram below.

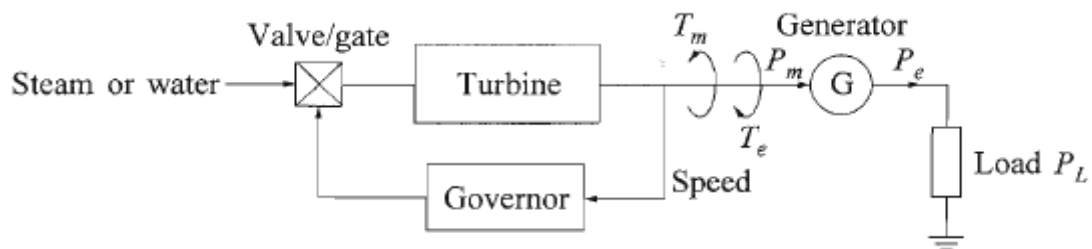

Figure A.0.1 Generator supplying isolated load [2]

Turbine-generator units operating in the power system contain stored kinetic energy due to their rotating masses [16]. If there is a sudden increase in system load, stored kinetic energy is released to initially supply the load increase. The electrical torque T_e of each turbine-generator unit increases to supply the load increase, while mechanical torque T_m of the turbine initially remains constant. From Newton's law of motion

$$J\alpha = T_m - T_e \quad (\text{A.1})$$

Where J = combined moment of inertia of generator and turbine in kg.m^2

T_m = mechanical torque in N.m

T_e = electromagnetic torque in N.m

α = acceleration coefficient

The acceleration α is therefore negative. Each turbine-generator decelerates and the rotor speed drops as kinetic energy is released to supply the load increase. When there is an unbalance between the torques acting on the rotor, the net torque causing acceleration (or deceleration) is

$$T_a = T_m - T_e \quad (\text{A.2})$$

Where T_a is the acceleration torque in N.m

T_m is the mechanical torque in N.m

T_e is the electromagnetic torque in N.m

The combined inertia of the generator and the prime mover is accelerated by the unbalanced in the applied torques. Hence, the equation of motion is

$$J \frac{dw_m}{dt} = T_a = T_m - T_e \quad (\text{A.3})$$

Where J is the combined moment of inertia of generator and turbine in kg.m^2

W_m is the angular velocity of the rotor, mech. Rad/s

t is the time, seconds

The rotor speed or generator frequency indicates a balance or imbalance of generator electrical torque T_e and turbine mechanical torque T_m [16]. If speed or frequency decreases, the electrical torque is greater than mechanical torque (neglecting generator losses). Similarly, if the speed or frequency increases, the electrical torque is less than mechanical torque.

A1.2 Steady state power balance in one area

Generator frequency is the appropriate control signal to govern the mechanical output power of the turbine [16]. The steady state frequency power relation for turbine-governor control is

$$\Delta p_m = \Delta p_{ref} - \frac{1}{R} \Delta f \quad (A.4)$$

Where Δp_m is the change in turbine mechanical power output

Δf is the change in frequency

Δp_{ref} is the change in a reference power setting

R is the regulation constant

The steady state frequency power relation for one area of an interconnected power system can be determined by summing (2.4) for each generator in the area. Noting that Δf is the same for each unit.

$$\begin{aligned} \Delta p_{m(area)} &= \Delta p_{m1} + \Delta p_{m2} + \Delta p_{m3} + \Delta p_{m4} + \dots \\ &= (\Delta p_{ref1} + \Delta p_{ref2} + \dots) - \left(\frac{1}{R_1} + \frac{1}{R_2} + \dots \right) \Delta f \\ &= \Delta p_{ref(area)} - \left(\frac{1}{R_1} + \frac{1}{R_2} + \dots \right) \Delta f \end{aligned} \quad (A.5)$$

Where $\Delta p_{m(area)}$ is the total change in turbine mechanical power within the area

$\Delta p_{ref(area)}$ is the total change in reference power settings within the area

The area frequency response β is defined as

$$\beta = \left(\frac{1}{R_1} + \frac{1}{R_2} + \dots \right) \quad (A.6)$$

Using (2.5) and (2.6)

$$\Delta p_{m(area)} = \Delta p_{ref(area)} - \beta \Delta f \quad (A.7)$$

A2 Generator response to load change

The load change is reflected instantaneously as a change in the electrical torque of the generator as explained in Appendix 1. This results in a mismatch between mechanical torque and electrical torque which leads to speed

variations as determined by the equation of motion. The following transfer function represents the relationship between rotor speed as a function of the electrical and mechanical torques.

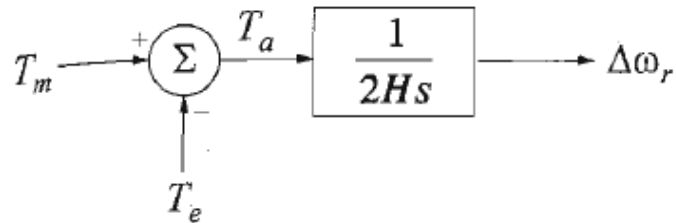

Figure A.0.2 Transfer function relating speed and torques [2]

Where: s = Laplace operator

T_m is the mechanical torque (p.u.)

T_e is the electrical torque (p.u.)

T_a is the acceleration torque (p.u.)

H is the inertia constant ($MW - sec/MVA$)

$\Delta\omega_r$ is the rotor speed deviation (p.u.)

The relationship between power P and torque T is given by

$$P = \omega_r T \tag{A.8}$$

Figure 2.3 can be express in ΔP_m and ΔP_e as follows

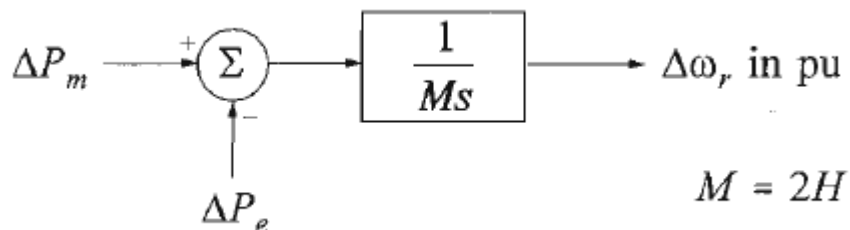

Figure A.0.3 Transfer function relating speed and power [2]

A3 Load response to frequency deviation

In general, the power system load is a composite of resistive loads and motor loads. Resistive loads are independent of the system frequency. For the motor loads, the electrical power changes with frequency due to changes in the motor speed. The overall frequency-dependent characteristic of a composite load may be expressed as:

$$\Delta P_e = \Delta P_L + D\Delta\omega_r \quad (\text{A.9})$$

Where: ΔP_L is the non –frequency sensitive load change

$D\Delta\omega_r$ is the frequency sensitive load change

D is the load damping constant (expressed as a percent change in the load for one percent change in frequency)

The block diagram including the effect of the load damping is shown below



Figure A.0.4 Rotor dynamics transfer function [2]

This can be expressed in standard form in terms of gain and time constant as:

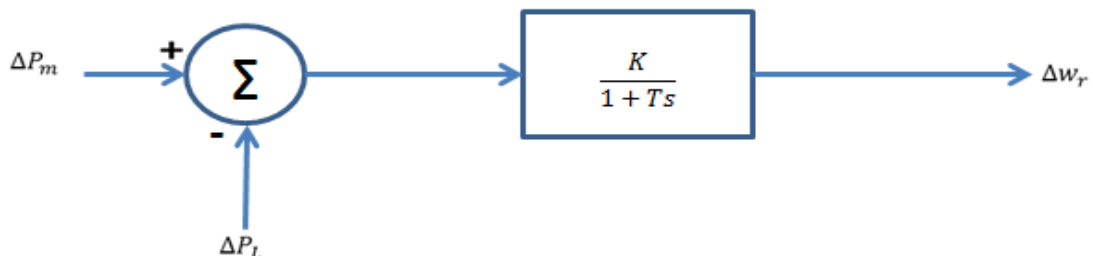

Figure A.0.5 Standard form block diagram

Where

$$K = 1/D, T = M/D \quad (\text{A.10})$$

In the case where there is no speed governor, the system response to a load change is determined by the inertia constant and the damping constant. This can be expressed as following:

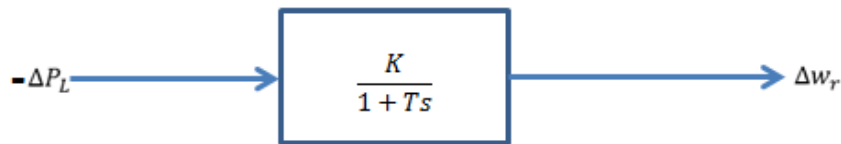

Figure A.0.6 System without governor

For a step reduction in load by x per unit, Laplace transform of the change in load is

$$\Delta P_L(s) = \frac{-x}{s} \quad (\text{A.11})$$

From block diagram

$$\begin{aligned} \Delta w_r(s) &= -\left(\frac{-x}{s}\right)\left(\frac{K}{1+sT}\right) \\ &= -xK e^{-\frac{t}{T}} + xK \end{aligned} \quad (\text{A.12})$$

For example if the change in load is 0.01 pu , $D = 0.75$, $M = 10$

$$\Delta P_L(s) = \frac{-0.01}{s}$$

$$\Delta w_r(s) = -\left(\frac{-0.01}{s}\right)\left(\frac{K}{1+sT}\right) = -0.01 * 1.33 e^{-\frac{t}{13.33}} + 0.01 * 1.33 = -0.0133 e^{-0.075t} + 0.0133$$

This gives a first order response with time constant $T = 13.33 \text{ seconds}$, steady state frequency deviation of 0.0133 p.u. ($\Delta P_L/D$).

A4 Interconnected systems theory

An electrical power system consists of many generating units and loads and the total demand varies throughout the day. As the load changes randomly, the area frequency and tie line power interchange also vary. The load changes are compensated using frequency control mechanisms to maintain the system frequency at the scheduled value and maintain the net power interchanges with the neighbouring control areas at their scheduled values.

Figure 2.2 shows the interconnected power system which consists of two areas connected by a tie line of the reactance X_{tie} . A control area is the portion of the interconnected power system to which a common generation and load scheme is applied. In Figure 2.3, the electrical equivalent of the system with which each area is represented by the voltage source behind the equivalent reactance is shown. The power flow on the tie line from area 1 to area 2 is

$$P_{12} = \frac{E_1 E_2}{X_T} \sin(\delta_1 - \delta_2) \quad (A13)$$

Where: E_1 is the terminal voltage in the generator representing area 1

E_2 is the terminal voltage in the generator representing area 2

X_T is the reactance of the transmission line between area 1 and area 2

δ_1 is the load angle of the generator representing area 1

δ_2 is the load angle of the generator representing area 2

Control areas are connected to their neighbouring areas via the tie-line. For Load-Frequency studies, each area can be represented by an equivalent generating unit exhibiting its overall performance as explained in Section 2.

The model shown in Figure 2.3 is widely used in the literature to evaluate multi-area system dynamic performance. Each area is represented by an equivalent inertia M , load damping constant D , turbine and the governing system with an effective droop R . The tie-line is represented by the synchronizing torque

coefficient T. The steady state frequency deviation ($f - f_0$) is the same for the two areas, hence

$$\Delta f = \Delta w_1 = \Delta w_2 \quad (\text{A14})$$

According to [2], for a load change of ΔP_L the frequency deviation is given by the following

$$\Delta f = \frac{-\Delta P_L}{(1/R_1 + 1/R_2) + (D_1 + D_2)} \quad (\text{A15})$$

Consider the steady state frequency deviation following an increase in area 1 load by ΔP_{L1}

$$\Delta f = \frac{-\Delta P_{L1}}{(1/R_1 + 1/R_2) + (D_1 + D_2)} = \frac{-\Delta P_{L1}}{\beta_1 + \beta_2} \quad (\text{A16})$$

And

$$\Delta P_{12} = \frac{-\Delta P_{L1} \beta_2}{\beta_1 + \beta_2} \quad (\text{A17})$$

A negative ΔP_{12} indicates the power flow from area 2 to area 1. For a load change in area 2 by ΔP_{L2}

$$\Delta f = \frac{-\Delta P_{L2}}{\beta_1 + \beta_2} \quad (\text{A18})$$

$$\Delta P_{12} = -\Delta P_{21} = \frac{\Delta P_{L2} \beta_1}{\beta_1 + \beta_2} \quad (\text{A19})$$

A5 Governor with speed droop

The power system consists of many generators connected in parallel. For a stable load division between the units operating in parallel, the governors are provided with a characteristic so that the speed drops as the load is increased. Schematic diagram of the governor equipped with droop characteristic is shown below.

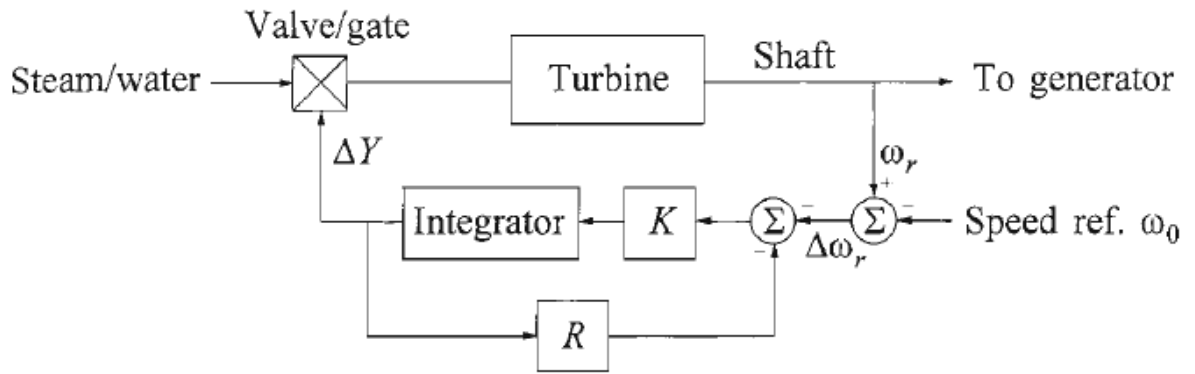

Figure A.0.7 Governor system equipped with droop characteristic [2]

The measured rotor speed w_r is compared with the reference speed w_0 . The value of R determines the steady state speed versus load characteristic of the generating unit. The ratio of the frequency deviation to the change in power output is equal to R as explained in Section 2.1.5. If two or more generators with droop governor characteristics are connected to a power system, there will be a unique frequency at which they will share a load change. If the percentages of regulation of the units are nearly equal, the change in the outputs of each unit will be nearly in proportion to its rating. Figure A.0.8 shows the response of generating units with a speed-droop governor when subjected to a load increase.

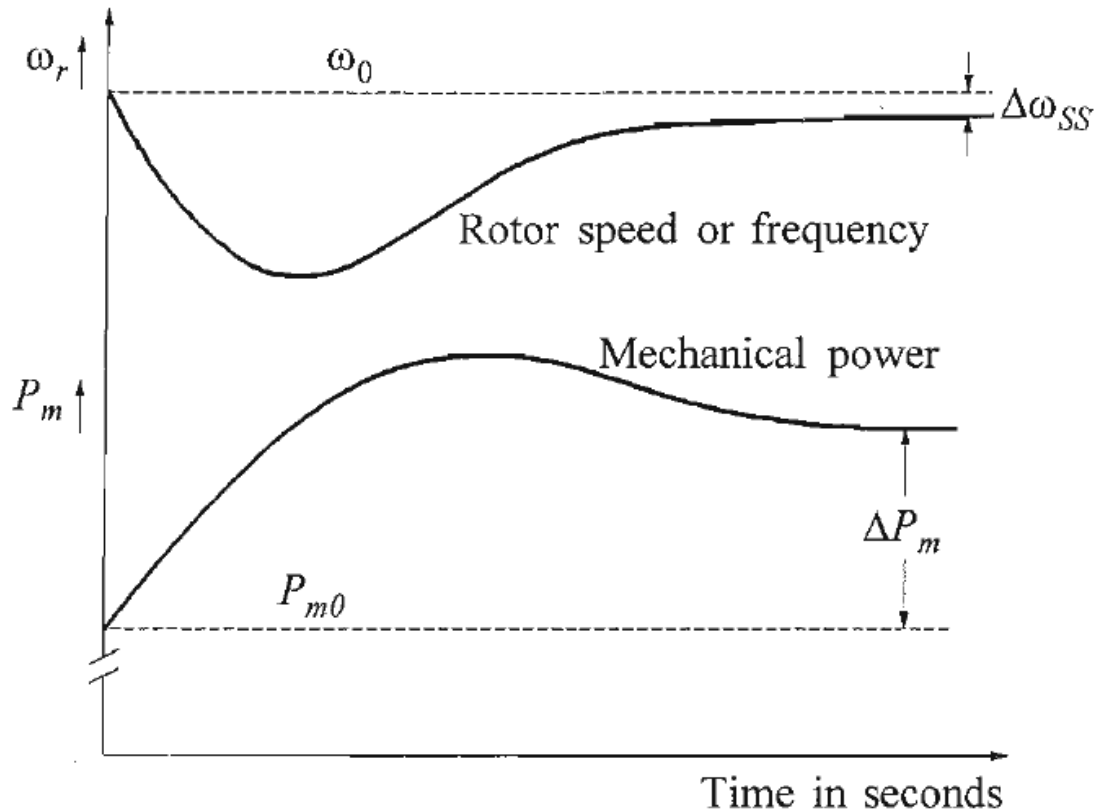

Figure A.0.8 Time response of a generating unit with a governor having speed-droop characteristic [2]

The increase in electrical power P_e causes the frequency decline at a rate determined by the system inertia. As the speed drops the turbine mechanical power increase, this arrests the frequency decay and then an increase in speed when the turbine power is in excess of the electrical power.

A6 Equivalent plant representing area

The steam turbine may be either reheat type or non-reheat type. Figure A.0.9 shows the block diagram of the generating unit with a reheat turbine. This diagram is for load frequency analysis. It includes representation of the speed governor, turbine, rotating mass and load. The turbine representation assumed constant boiler pressure. The block diagram is also applicable to a unit with non-reheat turbine, however, in that case $T_{RH} = 0$ and the turbine transfer

function will be simplified to: $\frac{1}{(1+sT_{CH})}$. The parameters are explained in Appendix C.

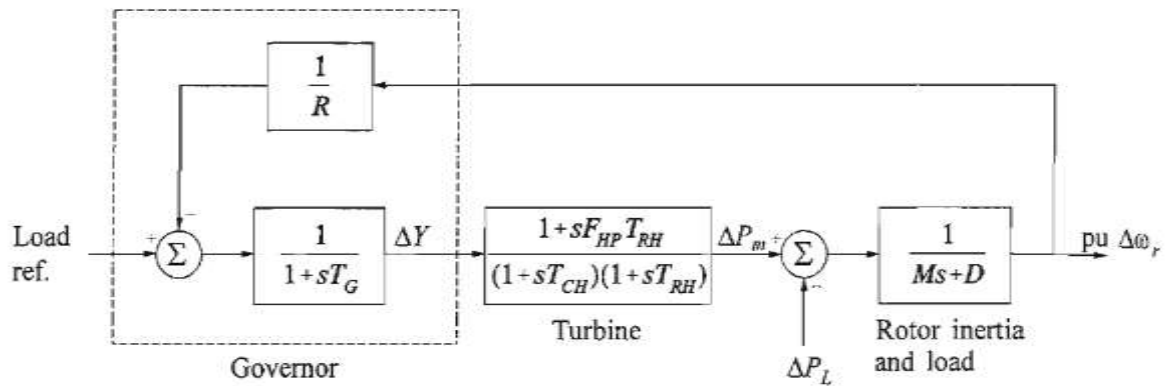

Figure A.0.9 Block diagram of the generating unit [2]

For load frequency studies, each area may be represented by an equivalent generating unit exhibiting its overall performance. Composite like this are accepted because inter-machine oscillations within the area are not a concern when performing load frequency control analysis.

A7 Literature review

In [5] the load frequency control models of a two-area interconnected power system with a stiff tie-line or an elastic tie-line were investigated with respect to modelling errors. Only multiplicative type modelling errors were considered for robustness analysis. In this paper it is highlighted that most two-area system models assume that the interconnections between areas are so stiff that the whole system can be characterized by a single frequency. Meaning the areas swing in unison during changes in area load. One of the important conclusions in [5] was that a more realistic model assumes weaker connections between the two areas and allows each area to control its own frequency. The model used for elastic/weaker tie-lines is the same as the model shown in Figure 2.19. The model was preferred because it represents in detail the speed governor and the turbine-generator systems in both areas.

In [7] a new model derived from [2] with substantial modifications is presented. One principal modification introduced concerns the turbine model. Another modification is the consideration of several types of generators in the system. The final modification is the consideration of the aggregate generation coefficient in forming the rotor angle as an input to the tie-line model.

In [4] the MATLAB Simulink dynamic model of the Load Frequency Control (LFC) of a realistic two- area power system having diverse sources of power generation is presented. The two-area power system model from [2] was modified by introducing the DC tie-line parallel to the AC line, to design the optimal output feedback controller for the realistic power system. In [8] the robust load frequency controller for two area interconnected power system is presented to quench the deviations in frequency and tie-line power due to different load disturbances. The two area power system model from [2] was used in the study.

In [6] the authors performed a study to establish the optimum megawatt-frequency control of multi-area power systems. The dynamic system model was developed on the assumption that the electrical connections within each individual control area are strong such that the whole area can be characterised by a single frequency only. The two-area system model employed is the same as the one shown in Figure 2.19. One of the reasons this model was chosen for the study is that it is the simplest of multi-area systems.

The literature shows that most researchers use a generic two-area power system model when performing multi-area system dynamic studies.

APPENDIX B: SYSTEM REQUIREMENTS AND PERFORMANCE EVALUATION

B1 South African Grid Code requirements

B1.1 Governor Requirements

The Grid Code requirement 6 (GCR 6) states that all units above 50 MVA shall have an operational governor capable of responding according to the minimum requirements set out in GCR 6 section. It also states that all thermal and hydro units with maximum continuous rating (MCR) greater than 50 MW shall be capable of automatic generation control (AGC), unless otherwise agreed with the System Operator. These two statements show that an operational governor is compulsory for units greater than 50 MVA and that AGC capability is compulsory for units greater than 50 MW.

B1.2 Frequency dead-band requirements

The South African Grid Code states “The maximum allowable dead band shall be 0.15 Hz for governing units contracted for instantaneous reserve and 0.5 Hz for units not contracted for instantaneous reserve. No response is required from the unit while the frequency is within the dead band.”

Summary of Governing Requirements

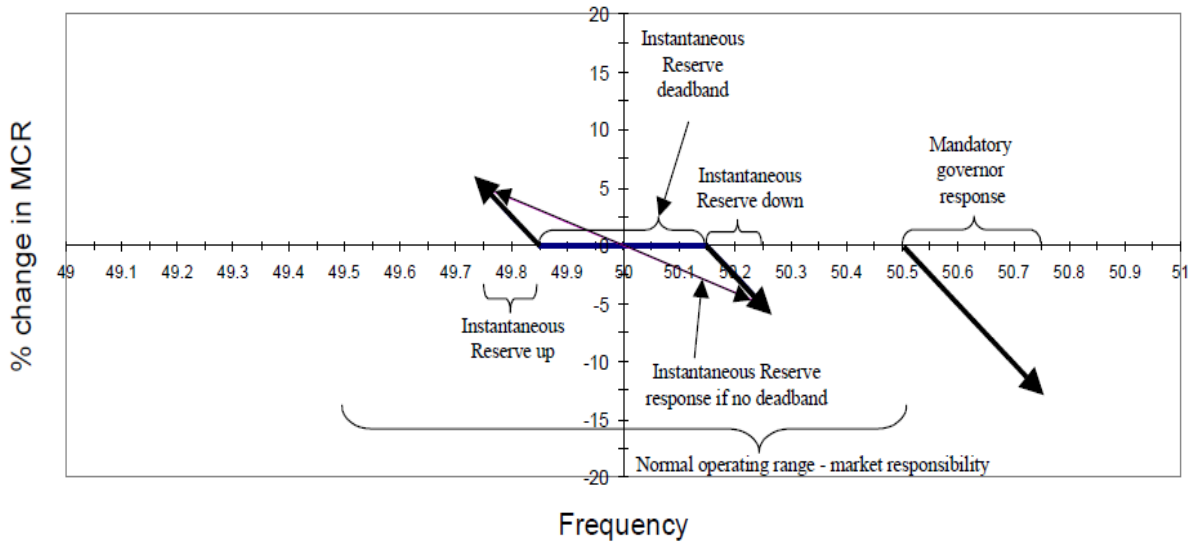

Figure B.0.1 Graphical representation of governing requirements [15]

B1.3 Droop settings requirements

According to [15] the governor shall be set to give 4% droop characteristic. “Coal-fired units not equipped with a dead band facility shall have a droop of 10% or less. At 49.75 Hz a unit that does not have a dead band and does not limit the response will respond two and a half times more than the unit on a 4% droop. If the desired response from coal-fired units is 5% of MCR sent out at 49,75Hz, then this is equivalent to a 10% droop with no dead band. This means the effective requirements from the units are the same.”[15]. Governing response shall be fully achieved within 10 seconds and shall be sustained for the duration of the excursion.

Basically, the units contracted for instantaneous reserves must have a dead-band of ± 0.15 Hz and 4% droop setting. If the unit does not have a dead-band it can have a droop setting of 10% or less. The effective requirements from the units are the same. The allowable dead band for units not contracted for instantaneous reserves is ± 0.5 Hz. These are the important grid code requirements for the project.

APPENDIX C: MODEL DEVELOPMENT AND VERIFICATION

The general model for steam turbine speed governing system is shown in Figure C.0.1. This model may be used to represent either a mechanical-hydraulic system or an electro-hydraulic system by means of an appropriate selection of parameters [13].

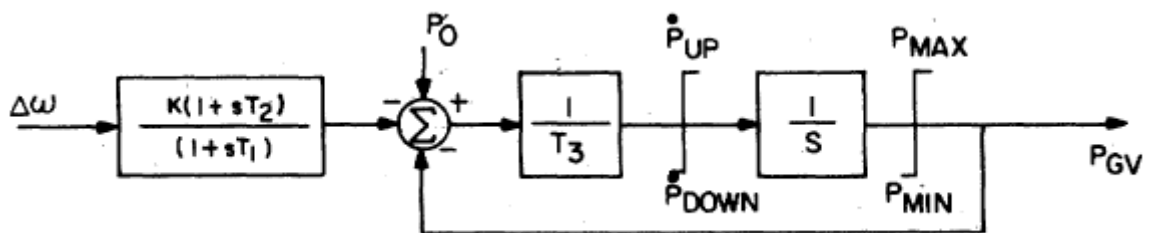

Figure C.0.1 General model for steam turbine speed governor system [13]

The general steam turbine speed governor model shows the load reference as an initial power P_0 . This is combined with the increments due to the speed deviation to obtain total power P_{GV} subject to servomotor mechanism time delay (T_3). Typical time constants for the general model of speed governing system are shown in the Table C.0.1.

Table C.0.1 Governor system's typical time constants

System	Time Constants (Seconds)		
	T1	T2	T3
Mechanical-Hydraulic	0.2-0.3	0	0.1
General Electric EH With Steam Feedback*	0	0	0.025
General Electric EH Without Steam Feedback	0	0	0.1
Westinghouse EH With Steam Feedback*	2.8**	1.0**	0.15
Westinghouse EH Without Steam Feedback	0	0	0.1

$K = 100/(\% \text{ Steady-State Speed Regulation})$

** These values may vary considerably from one unit to another

Table C.0.2 IEEE G1 parameters [14]

Parameter	Description
K	Governor gain (1/droop) [pu]
T1	Lag time constant [s]
T2	Lead time constant [s]
T3	Valve position time constant [s]
Uo	Maximum valve opening rate [pu/s]
Uc	Maximum valve closing rate [pu/s]
Pmax	Maximum valve opening, on MW capability [pu]
Pmin	Minimum valve opening, on MW capability [pu]
T4	Time constant for steam inlet [s]
K1	HP fraction
K2	LP fraction
T5	Time constant for second boiler pass [s]
K3	HP fraction
K4	LP fraction
T6	Time constant for third boiler pass [s]
K5	HP fraction
K6	LP fraction
T7	Time constant for fourth boiler pass [s]
K7	HP fraction
K8	LP fraction
db1	deadband

Table C.0.3 IEEEG1 parameters on DlgSILENT simulation package

Parameter	Description	Default Value
K	Controller Gain [p.u.]	5
T1	Governor Time Constant [s]	0.2
T2	Governor Derivative Time Constant [s]	1
T3	Servo Time Constant [s]	0.6
K1	High Pressure Turbine Factor [p.u.]	0.3
K2	High Pressure Turbine Factor [p.u.]	0
T5	Intermediate Pressure Turbine Time Constant [s]	0.5
K3	Intermediate Pressure Turbine Factor [p.u.]	0.25
K4	Intermediate Pressure Turbine Factor [p.u.]	0
T6	Medium Pressure Turbine Time Constant [s]	0.8
K5	Medium Pressure Turbine Factor [p.u.]	0.3
K6	Medium Pressure Turbine Factor [p.u.]	0
T4	High Pressure Turbine Time Constant [s]	0.6
T7	Low Pressure Turbine Time Constant [s]	1
K7	LowPressure Turbine Factor [p.u.]	0.15
K8	LowPressure Turbine Factor [p.u.]	0
PNhp	HP Turbine Rated Power (=0->PNhp=PgnnHP) [MW]	0
PNlp	LP Turbine Rated Power (=0->PNhp=PgnnHP) [MW]	0
Uc	Valve Closing Time [p.u./s]	-0.3
Pmin	Minimum Gate Limit [p.u.]	0
Uo	Valve Opening Time [p.u./s]	0.3
Pmax	Maximum Gate Limit [p.u.]	1

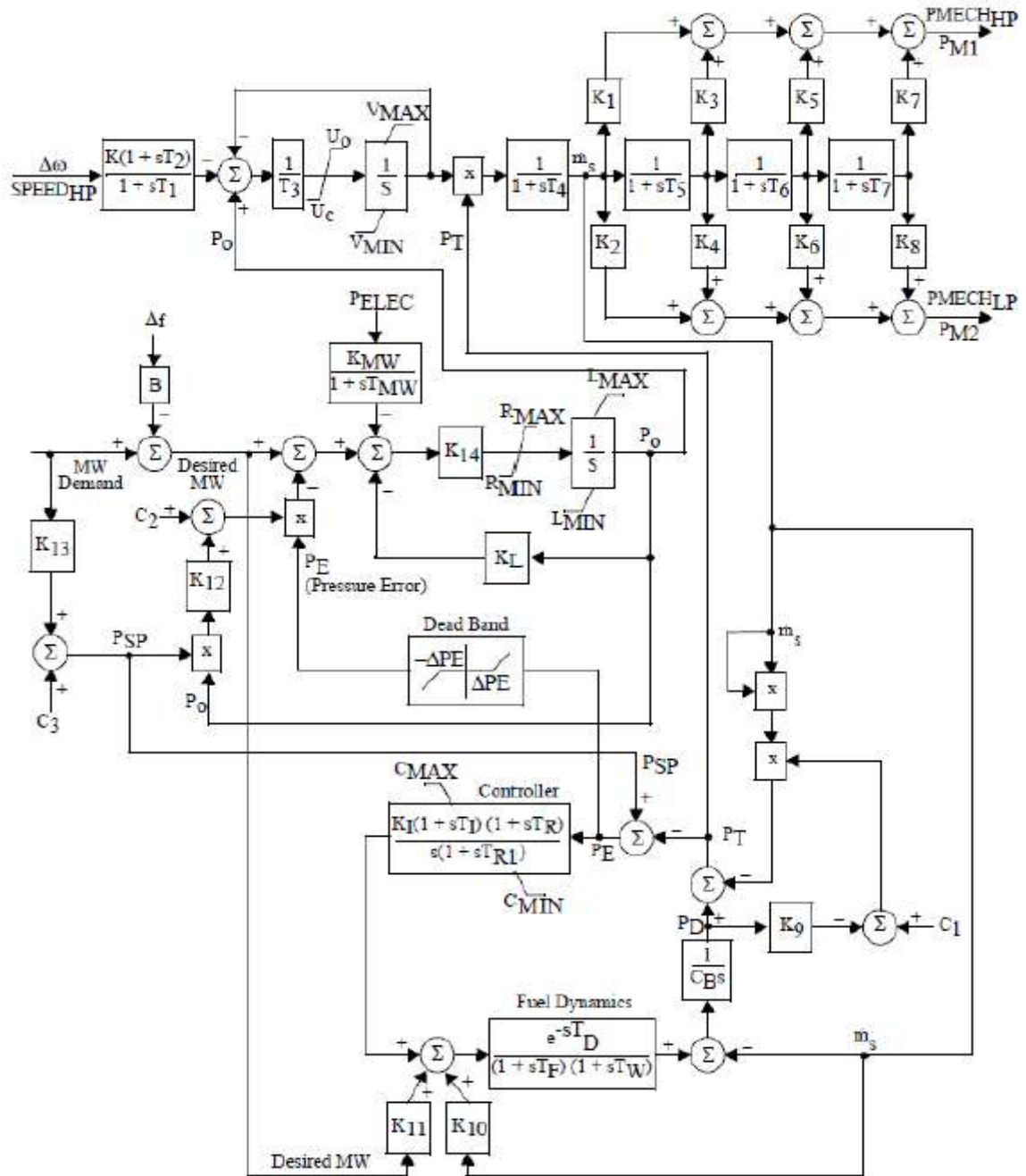

Figure C.0.2 TGOV5 block diagram [14]

Table C.0.4 TGOV5 default parameters on DigSILENT simulation package

Parameter	Description	Default Value
K	Controller Gain [p.u.]	5
T1	Governor Time Constant [s]	0.2
T2	Governor Derivative Time Constant [s]	1
T3	Servo Time Constant [s]	0.6
K1	High Pressure Turbine Factor [p.u.]	0.3
K2	High Pressure Turbine Factor [p.u.]	0
T5	Intermediate Pressure Turbine Time Constant [s]	0.5
K3	Intermediate Pressure Turbine Factor [p.u.]	0.25
K4	Intermediate Pressure Turbine Factor [p.u.]	0
T6	Medium Pressure Turbine Time Constant [s]	0.8
K5	Medium Pressure Turbine Factor [p.u.]	0.3
K6	Medium Pressure Turbine Factor [p.u.]	0
T4	High Pressure Turbine Time Constant [s]	0.6
T7	Low Pressure Turbine Time Constant [s]	1
K7	LowPressure Turbine Factor [p.u.]	0.15
K8	LowPressure Turbine Factor [p.u.]	0
PNhp	HP Turbine Rated Power (=0->PNhp=PgnnHP) [MW]	0
PNlp	LP Turbine Rated Power (=0->PNhp=PgnnHP) [MW]	0
B	The frequency bias for load reference control [p.u.]	0.05
K13	The gain between MW demand and pressure set point	0.02
K12	The gain for pressure error bias	0.02
Kmw	The gain of the MW transducer (0 or 1)	1
Tmw	The MW transducer time constant [s]	10
K14	Inverse of load reference servomotor time constant [s] (=0.0 if the load referenece does not change)	5
KI	The feedback gain from the load reference (0 or 1)	1
Dpe	The deadband in the pressure error signal for load reference control [p.u. of Pressure]	0.001
Ki	The controller integral gain [p.u.]	0.02
Ti	The controller proportional lead time constant [s]	90
Tr	The controller rate lead time constant [s]	60
Tri	The inherent lag associated with lead TR [s]	6
K9	The adjustment to the pressure drop coefficient as a function of drum pressure	0
Cb	The boiler storage time constant [s]	750
Tf	The fuel and air system time constant [s]	25
Tw	Fuel flow time constant [s]	7
Td	The time delay in the fuel supply system [s]	60
K11	The gain of anticipation signal from load demand	0.1
K10	The gain of anticipation signal from main steam flow	0.1
C1	The pressure drop coefficient	0.2
Psp	The initial throttle pressure set point	1
C2	The gain for pressure error bias	0
C3	The adjustment to the pressure set point	1
Uc	Valve Closing Time [p.u./s]	-0.3
Vmin	Minimum Gate Limit [p.u.]	0
Rmin	The load reference negative rate of change limit [p.u./s]	-0.3
Lmin	The minimum load reference [p.u.]	0.2
Cmin	The minimum controller output [p.u.]	0.1
Uo	Valve Opening Time [p.u./s]	0.3
Vmax	Maximum Gate Limit [p.u.]	1
Rmax	The load reference positive rate of change limit [p.u./s]	0.3
Lmax	The maximum load reference [p.u.]	1
Cmax	The maximum controller output [p.u.]	1.2

In [13] the six common steam configurations and corresponding mathematical models are shown. The time constants and fractions representing steam turbine's behaviour are discussed. Typical values for time delays and cylinder fractions are shown in Table C.0.5.

Table C.0.5 Steam turbine parameters

Steam system configuration	FVHP	FHP	FIP	FLP	TCH	TRH TRH1	TRH2	Tco
Non reheat	-	-	-	-	0.2-0.5	-	-	-
Tandem-Compound Single-Reheat	-	0.3	0.4	0.3	0.1-0.4	(4) - (11)	-	0.3-0.5
Tandem-Compound Double-Reheat	0.22	0.22	0.3	0.26	0.1-0.4	(4) - (11)	(4) - (11)	0.3-0.5
Cross-Compound Single-Reheat	-	0.3	0.3	0.4	0.1-0.4	(4) - (11)	-	0.3-0.5
Cross-Compound Single-Reheat	-	0.25	0.25	0.5	0.1-0.4	(4) - (11)	-	0.3-0.5
Cross-Compound Double-Reheat	0.22	0.22	0.22	0.28	0.1-0.4	(4) - (11)	-	0.3-0.5

Table C.0.6 Translation of steam turbine parameters to general model

Steam system configuration	Time Constants				Fractions							
	T4	T5	T6	T7	K1	K2	K3	K4	K5	K6	K7	K8
Non reheat	TCH	-	-	-	1	0	0	0	0	0	0	0
Tandem-Compound Single-Reheat	TCH	TRH	Tco	-	FHP	0	FIP	0	FLP	0	0	0
Tandem-Compound Double-Reheat	TCH	TRH1	TRH2	Tco	FVHP	0	FHP	0	FIP	0	FLP	0
Cross-Compound Single-Reheat	TCH	TRH	Tco	-	FHP	0	0	FIP	FLP/2	FLP/2	0	0
Cross-Compound Single-Reheat	TCH	TRH	Tco	-	FHP	0	FIP	0	0	FLP	0	0
Cross-Compound Double-Reheat	TCH	TRH1	TRH2	Tco	FVHP	0	0	FHP	FIP/2	FIP/2	FLP/2	FLP/2

All common steam system configurations can be represented by the block diagram shown in Figure C.0.3.

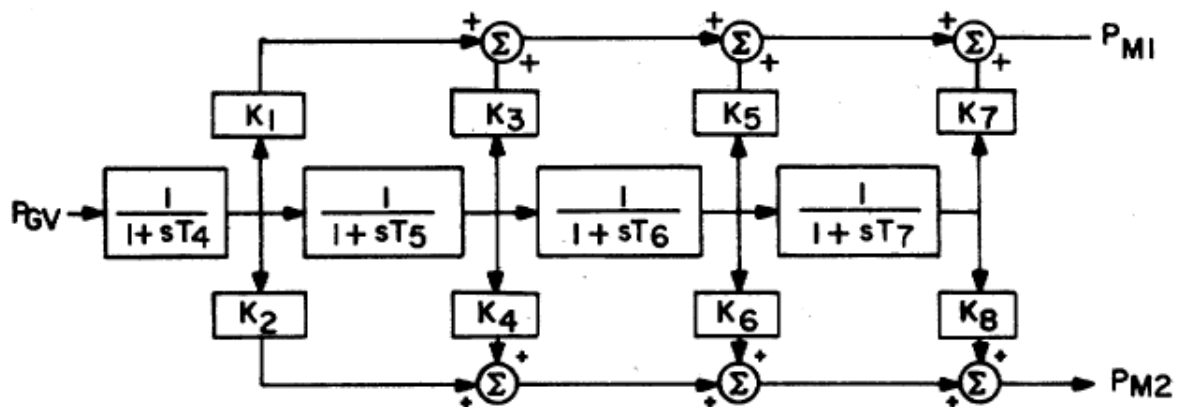

Figure C.0.3 General steam turbine model

Figure C.3.

The parameters in the generic turbine model are not similar to time constants and fractions the parameters used to express steam turbine behaviour. Table C.0.3 shows the interpretation of the parameters used in the general turbine model. The generator parameters and steam turbine parameters used in the study were based on typical generator parameters in the Eskom network.

Table C.0.7 TGOV5 (without dead band) model parameters

TGOV5 parameter	Value
K	137
T1	10
T2	1
T3	0.15
K1	0.3
K2	0
T5	9
K3	0.4
K4	0
T6	9
K5	0.3
K6	0
T4	0.4
T7	0.15
K7	0
K8	0
PNhp	0
PNlp	0
B	25
K13	0
K12	0
Kmw	1
Tmw	1
K14	0.1
Kl	0
Dpe	0.1
Ki	0.0012
Ti	655
Tr	4250
Tri	4380
K9	0
Cb	200
Tf	25
Tw	7
Td	90
K11	0
K10	0
C1	0.2
Psp	1
C2	10
C3	1
Uc	-0.1
Vmin	0.2
Rmin	-0.01
Lmin	0
Cmin	0.1
Uo	0.1
Vmax	1
Rmax	0.01
Lmax	1.1
Cmax	1.1

Table C.0.8 TGOV5 (with dead band) model parameters

TGOV5 parameter	Value
K	500
K1	0.3
K2	0
K3	0.4
K4	0
K5	0.3
K6	0
K7	0
K8	0
K9	0
K10	0
K11	0
K12	0
K13	0
K14	0.1
C1	0.2
C2	10
C3	1
DB_gov	0.003
DB_p	0
T1	15
T2	1
T3	0.15
T4	0.4
T5	9
T6	9
T7	0.15
Kmw	1
Tmw	1
Ki	0.0012
Tr1	4380
Ti	655
Tf	25
Tr	4250
Cb	200
Td	90
Tw	7
Kl	0
dPe	0.1
B	125
Tpower	0
Freqlimit_min	-0.00166
Psp_min	0.5
Cmin	0.1
Lmin	0
Vmin	0.2
Rmin	-0.01
Uc	-0.1
Freqlimit_max	0.03
Psp_max	1.05
Cmax	1.1
Lmax	1.1
Vmax	1
Rmax	0.01
Uo	0.1

