

THE CONTROL OF POWER ELECTRONIC CONVERTERS FOR GRID CODE COMPLIANCE IN WIND ENERGY GENERATION SYSTEMS

Shaun Ramsumar

A research report submitted to the Faculty of Engineering and the Built Environment, University of the Witwatersrand, Johannesburg, in partial fulfilment of the requirements for the degree of Master of Science in Engineering.

Johannesburg, 2015

Declaration

I declare that this research report is my own unaided work. It is being submitted to the Degree of Master of Science to the University of the Witwatersrand, Johannesburg. It has not been submitted before for any degree or examination to any other University.



.....

Shaun Ramsumar

Signed this 11th day of May, 2015

Abstract

This research report reviews some of the latest control schemes for the power electronic converters found in modern variable speed wind turbines in order to comply with various grid codes. Various control schemes, in order to comply with low voltage ride-through requirements, active and reactive power control and frequency control, are presented. The report first investigates the South African grid code requirements for wind energy generation, and then makes a comparison to grid codes of countries with significant penetration levels and vast experience in wind energy generation. This is followed by a review of the state of the art in fixed and variable speed wind turbine technologies. The research revealed that Type 3 generators offer significant advantages over others but suffer due to grid faults. Various active control schemes for fault ride-through were researched and the method of increasing the rotor speed to accommodate the power imbalance was found to be the most popular. It was found that Type 4 generators offer the best fault ride-through capabilities due to their full scale converters. The research will assist power system operators to develop appropriate and effective grid codes to enable a stable and reliable power system. The research will also provide turbine manufacturers and independent power producers with a comprehensive view on grid codes and relate them to the associated turbine technologies.

Acknowledgements

I would like to thank Dr J. M. van Coller of the School of Electrical and Information Engineering, of the University of the Witwatersrand who inspired the topic and provided his undivided attention and support during the research. I would also like to thank Mr D. Bhana and Mr Y. Brijmohan of the Ethekweni Municipality for their guidance and support.

Contents

Declaration	i
Abstract	ii
Acknowledgements	iii
Contents	iv
List of Figures	vi
List of Tables	viii
List of Symbols	ix
Nomenclature	xi
1 Introduction	1
1.1 Research Questions	2
1.2 Chapter Overview	3
2 Background and Grid Codes for Wind Energy Generation	4
2.1 Background to the South African Grid Code	4
2.2 Review of Grid Code Specifications	5
2.2.1 Fault Ride-Through Requirements	6
2.2.2 Active and Reactive Power Response under Disturbances	9
2.2.3 Extended Range of Frequency-Voltage Variations	12
2.2.4 Active Power Control and Frequency Regulation	14
2.2.5 Reactive Power Control and Voltage Regulation	16

3	Wind Turbine Technologies	18
3.1	Technological Background	18
3.2	Fixed Speed WECS	19
3.3	Variable Speed WECS	21
3.3.1	DFIG with Partial Rated Converter	22
3.3.2	SCIG with Full Scale Converter	23
3.3.3	SG with Full Scale Converter	23
4	Grid Compliance Technologies	25
4.1	Background	25
4.2	Fault Ride-Through Control	26
4.2.1	DFIG Control by Temporary Increase of Rotor Speed	27
4.2.2	DFIG with DC Link Chopper	30
4.2.3	Hybrid Current Control of DFIG	32
4.2.4	Power Compensation Feedback in Full Scale Converters	34
4.3	Reactive Power Control	36
4.3.1	Control using the STATCOM	36
4.3.2	Coordinated Control using the Interface Neurocontroller	38
4.4	Frequency Control	39
4.4.1	Siemens Patent for Dynamic Power Output	40
4.4.2	VESTAS Patent for Power Curtailment	41
4.4.3	Inertia Control	43
4.4.4	Continuous Frequency Regulation	44
5	Conclusion	46
	References	49

List of Figures

Chapter 2

2.1	LVRT specification for a category A1 and A2 WPP.	7
2.2	LVRT specification for a category A3, B and C WPP.	7
2.3	LVRT specification in the Irish grid code.	8
2.4	Reactive power support in the grid code for SA.	10
2.5	Reactive power support for the German grid code.	11
2.6	South African frequency operating range.	12
2.7	Active power requirements for category B & C WPPs in SA.	14
2.8	Danish active power constraint functions.	15
2.9	Active/reactive power requirements for category C WPPs in SA.	16
2.10	Voltage support requirements for category C WPPs in SA.	17

Chapter 3

3.1	Fixed speed wind power generator with a SCIG.	19
3.2	Limited speed range wind power generator adopting a WRIG.	20
3.3	Variable speed WECS adopting a DFIG and partially rated converter.	22
3.4	Variable speed WECS adopting a SCIG and full scale converter.	23
3.5	Variable speed WECS adopting an EESG and full scale converter.	24
3.6	Variable speed WECS adopting a PMSG and full scale converter.	24

Chapter 4

4.1	Control scheme of the RSC for normal and fault operation.	28
4.2	Control scheme of the GSC for normal and fault operation.	29
4.3	DC link of DFIG wind turbine with DC link chopper.	30
4.4	Control scheme of the proposed hybrid current regulator.	32
4.5	Practical implementation of the VBHCR.	33
4.6	Proposed DC link voltage control scheme for full scale converter.	34
4.7	MSC current reference generator.	35
4.8	STATCOM control scheme for fault ride-through support.	37
4.9	Coordinated control of STATCOM and wind farm using the INC.	38
4.10	Individual active power modulation as patented by Siemens.	40
4.11	DFIG Control scheme for power curtailment.	42
4.12	Simplified inertial control of a variable speed wind turbine.	43
4.13	Control scheme of continuous frequency control with a DFIG.	45

List of Tables

Chapter 2

2.1	International LVRT requirements under symmetrical faults.	9
2.2	International HVRT requirements under symmetrical faults.	9
2.3	Frequency limits in international grid codes.	13
2.4	Power factor limit specifications for international grid codes.	17

List of Symbols

E	Machine electromotive force
f_{BD}	Nominal frequency band
i_{dg}	d -component of grid current
i_{qg}	q -component of grid current
i_{dr}	d -component of rotor current
i_{qr}	q -component of rotor current
i_{qm}	q -component of stator current
i_{or}	DC current in the RSC
i_{os}	DC current in the GSC
J	Moment of inertia of wind turbine
K_{df}	Weighting constant (frequency deviation derivative)
K_{pf}	Weighting constant (frequency deviation)
L_m	Mutual inductance: stator and rotor
L_s	Stator Inductance
P_f	Reference active power (grid frequency)
P_ω	Reference active power (rotor speed)
P_r	Rotor active power
P_{GSC}	Active power from grid side converter
P_{comp}	Power compensation term
P_{cmd}	Power command signal
$P_{reserve}$	Generating margin

P_{GEN}	Generator active power
P_{wind}	Wind power
$P_{\text{WT max}}$	Maximum power available from wind turbine (MPPT)
Q_G	Grid reactive power
Q_s	Stator reactive power
Q_{STAT}	Reactive power from STATCOM
T_{cmd}	Reference torque command
T_{eref}	Reference electromagnetic torque
T_m	Turbine torque
V_{DC}	DC link voltage
V_w	Wind velocity
V_G	Grid voltage
v_{dr}	d -component of rotor voltage
v_{qr}	q -component of rotor voltage
v_{dg}	d -component of grid voltage
v_{qg}	q -component of grid voltage
ω_r	Rotor speed
ω_s	Stator synchronous speed
ψ_s	Stator flux

Nomenclature

AGC	Automatic Generation Control
DFIG	Doubly Fed Induction Generator
ECS	Energy Capacitor Systems
ESS	Energy Storage Systems
FACTS	Flexible AC Transmission Systems
GSC	Grid Side Converter
GTO	Gate Turn-off
GWEC	Global Wind Energy Council
HCS	Hill Climb Searching
HDP	Heuristic Dynamic Programming
HVRT	High Voltage Ride-Through
INC	Interface Neurocontroller
LVRT	Low Voltage Ride-Through
MSC	Machine Side Converter
NERSA	National Energy Regulator of South Africa
PCC	Point of Common Coupling
PI	Proportional-Integral
PMSG	Permanent Magnet Synchronous Generator
RBFNN	Radial Basis Function Neural Networks
RSC	Rotor Side Converter
SA	South Africa

SCIG	Squirrel Cage Induction Generator
SG	Synchronous Generator
SSSC	Static Series Synchronous Compensator
STATCOM	Static Synchronous Compensator
TSR	Tip Speed Ratio
VBHCR	Vector-Based Hysteresis Current Regulator
WECS	Wind Energy Conversion System
WPP	Wind Power Plant

Chapter 1

Introduction

Wind energy generation systems have become a key research area in the field of renewable energy. The Global Wind Energy Council (GWEC) reported a total of 318 GW of wind generating capacity installed globally at the end of 2013. This stemmed from an annual average growth rate of 21 percent over the last 10 years [1]. The GWEC report also predicts that the total global installed capacity could reach 600 GW by the end of 2018. The rapid rate of increase in wind energy penetration has forced electricity supply industries around the world to define specific grid codes for wind energy generation systems. The definition of specific grid codes is primarily due to the use of power electronic converter technologies in these non-conventional asynchronous generators. The use of modern power electronic converters result in variable speed wind turbines not exhibiting characteristics of conventional synchronous generators (SG). It is therefore crucial for any market with significant levels of wind energy penetration to define and comply with comprehensive grid codes in order to maintain power system stability and reliability.

1.1 Research Questions

The following research questions were proposed during the initial stages of the research and forms the basis of this report:

1. What is the background of the South African grid code for renewable energy generation and what are its specifications?
2. How does the South African grid code compare with grid codes of other countries around the world?
3. What are the various topologies of wind energy generation systems and how do they compare in performance and grid code compliance?
4. How are the power electronic converters in the wind generators controlled in order to achieve grid compliance?

This research report starts with an investigation and brief review of the South African grid codes for the integration of wind energy. Comparisons are then made to grid codes of countries around the world with extensive experience and significant penetration levels of wind energy. This is followed by an investigation into the modern wind turbine topologies and architectures. The purpose of this investigation was to establish the relationship between the topology of the wind turbines and its ability to comply with common grid code requirements. The brief background on grid codes and wind turbine topologies then lead to the next part of the research: investigating how the power electronic converters in modern wind turbine topologies are controlled in order to comply with grid code requirements. The most common concern in grid code compliance is grid stability under fault conditions as well as active/reactive power control and frequency regulation. This research report will provide independent power producers with an accurate understanding of the latest international grid codes relating to renewable energy and enable them to develop wind farms that comply with the applicable grid codes. This report will also assist turbine manufacturers in designing robust and flexible power converters to comply with international grid codes with minimal modifications and cost.

1.2 Chapter Overview

Chapter 2 provides a brief background and reviews the South African grid code for wind energy generation. The South African grid code is then compared to the grid codes of countries with extensive experience and penetration levels in wind energy.

Chapter 3 presents a comprehensive review of existing wind turbine technologies as well as the state of the art in wind energy conversion systems.

Chapter 4 reviews some of the latest grid code compliance technologies for variable speed wind power generation systems. This is presented in the form of control strategies for the power electronic converters in partial and full scale converter type wind power generator topologies.

Chapter 5 discusses the findings of this research report and provides a conclusion to the work.

Chapter 2

Background and Grid Codes for Wind Energy Generation

This chapter provides a brief background to the South African grid code and that of other countries. The study and comparison of grid codes is crucial as it forms the basis of compliance technologies and control strategies in wind turbines. The technical specifications stipulated in the South African grid code are discussed and these specifications are compared to those of countries around the world with extensive experience in renewable energy generation.

2.1 Background to South African Grid Code

The drastic increase in installed wind energy capacity in the last decade has resulted in many energy regulatory bodies defining specific grid codes for wind energy generation. In South Africa, the South African Department of Energy is responsible for the laws governing the energy sector. The National Energy Regulator of South Africa (NERSA) is given the mandate by the South African Government for rule setting and tariff determination in the South African electricity supply industry [2]. NERSA obtains its jurisdictional powers from existing legislation and the following acts: National Energy Regulator Act [3], Electricity Regulation Act [4], Electricity Pricing Policy [5] and the Electricity Regulation Amendment Act [6].

2.2 Review of Grid Code Specifications

The technical specifications in most international grid codes enforced on large wind power plants (WPP) can be classified into the following five categories:

1. Fault ride-through requirements.
2. Active and reactive power responses under disturbances.
3. Extended range of frequency-voltage variations.
4. Active power control and frequency regulation.
5. Reactive power control and voltage regulation.

In the event of a fault occurrence in an electrical network, the network supply voltage drops until protection systems and devices detect the fault and isolate it from the remaining network. During the fault occurrence, wind power generators experience a voltage sag condition at its terminals depending on the nature and the location of the fault. The voltage sag at the terminals can result in wind farms disconnecting from the grid due to severe internal stability concerns within the wind power generator. The instabilities within the power generator are mainly due to their sophisticated power electronic and variable speed technologies [7].

Wind farms disconnecting from power grids due to various forms of grid disturbances is unacceptable in grids that contain significant levels of wind power. Grid codes of all countries that have significant wind power production require the generators to remain connected to the grid and continue with power production under specified voltage and power profiles stipulated in their grid codes. Some international grid codes require WPPs to continuously operate under specified deviations of voltage and/or frequency in a range referred to as the 'normal operation area' [7]. Most grid codes also require WPPs to provide reactive power support in the event of faults and provide ancillary service provision. In comparison to conventional power plants, wind turbines are characterised by fixed and variable speed induction generators, doubly fed induction generators and synchronous generators.

All of the variable speed configurations employ back-to-back power electronic converters and exhibit electrical characteristics very different to those of conventional synchronous generators. Conventional power plants are able to support the stability of the transmission system by providing inertial response, power synchronisation, oscillation damping, short circuit capability and voltage backup during faults [8]. Grid codes therefore demand WPPs to exhibit conventional generator type characteristics in the interest of power system stability and reliability.

2.2.1 Fault Ride-Through Requirements

All international grid codes for renewable energy require WPPs to provide uninterrupted power to the grid under predefined fault conditions according to specified voltage-time profiles. This grid code requirement is referred to as low voltage ride-through (LVRT). The South African grid code requirement for LVRT depends on the power category of the wind plant as below [9].

Category A: rated power < 1 MVA connected to the LV ($LV \leq 1$ kV).

Category A1: sub-category of category A, rated power ≤ 13.8 kVA.

Category A2: sub-category of category A, 13.8 kVA < rated power < 100 kVA.

Category A3: sub-category of category A, 100 kVA \leq rated power < 1 MVA.

Category B: 1 MVA \leq rated power < 20 MVA or rated power < 1 MVA connected to the MV (1 kV < MV ≤ 33 kV).

Category C: 20 MVA or higher.

Figure 2.1 illustrates the LVRT specification for a category A1 or A2 WPP where it must remain connected to the grid until a voltage drop to 0.6 p.u at the point of common coupling (PCC) for 0.15 s. The normal operating range for WPPs in this category is specified between 0.85 p.u and 1.1 p.u of the nominal grid voltage.

Figure 2.2 illustrates the LVRT specification of a category A3, B or C WPP where it must remain connected to the grid until a voltage drop down to 0.0 p.u is measured at the PCC for 0.15 s. The normal operating range in this category is specified between 0.9 p.u and 1.1 p.u. Disconnection of the WPP is allowed outside areas A, B and D.

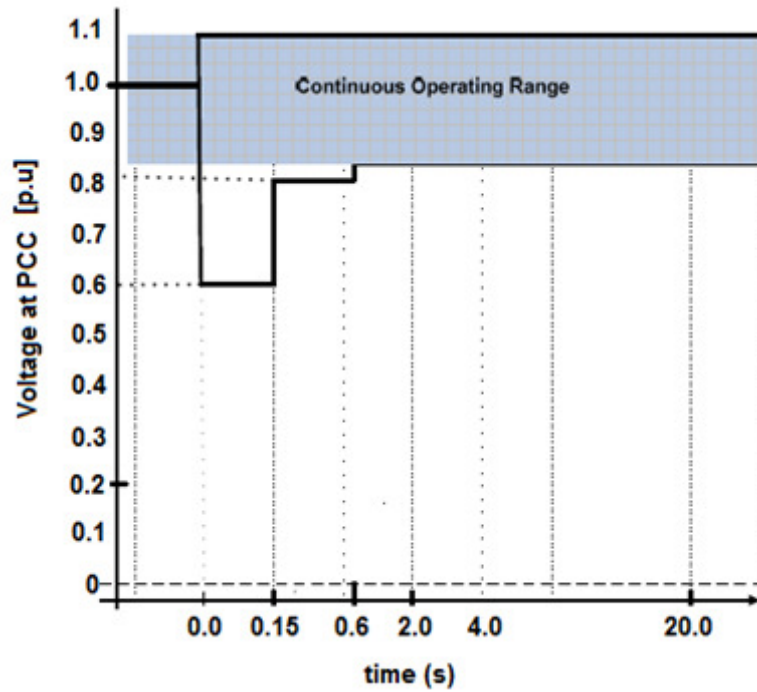

Figure 2.1: LVRT specification for a category A1 and A2 WPP [9].

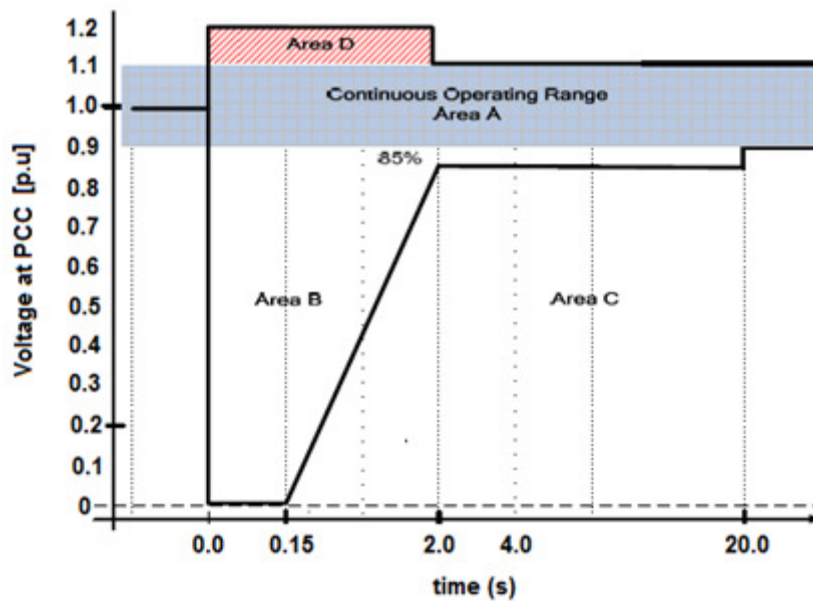

Figure 2.2: LVRT specification for a category A3, B and C WPP [9].

Some international grid codes like that of Australia, Denmark, Germany and Spain have specified maximum voltage profiles that allow disconnection of WPPs in the event of voltage swell. This is commonly referred to as the high voltage ride-through (HVRT) specification as presented in Table 2.2. Voltage swells are normally initiated by switching off large loads, energising capacitor banks or reoccurring general faults on the power grid [7]. The HVRT specification in the South African grid code is applicable to all categories of WPPs as illustrated in Figure 2.1 and Figure 2.2 by the upper solid line in each figure.

Figure 2.3 illustrates the LVRT grid code specification for Ireland. The minimum threshold for the voltage at the PCC is 0.15 p.u for a maximum duration of 625 ms, hence, any voltage profile outside the shaded area would allow the disconnection of the WPP from the grid [10].

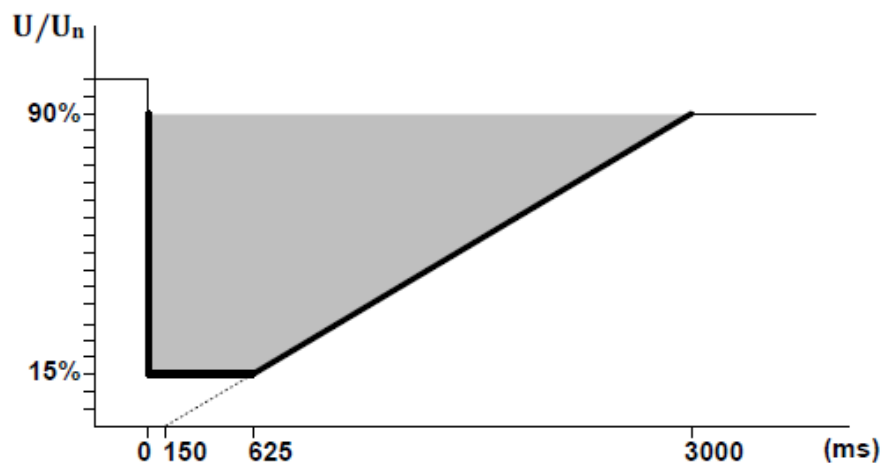

Figure 2.3: LVRT specification in the Irish grid code [10].

Table 2.1 and Table 2.2 show the LVRT and HVRT grid specifications respectively for some international grid codes under symmetrical fault conditions. Each country specifies their own fault ride-through parameters based on their power grid structure and installed renewable energy capacity. The most stringent requirement for the LVRT under asymmetrical fault conditions is defined by the Australian grid code where their WPPs are required to ride-through any asymmetrical faults of 0.0 p.u for 400 ms [7].

Table 2.1: International LVRT requirements under symmetrical faults [7].

Country	During Fault		Fault Clearance	
	V_{\min} (p.u)	T_{\max} (s)	V_{\min} (p.u)	T_{\max} (s)
Australia	0.00	0.10	0.70	2.00
Canada	0.00	0.15	0.85	1.00
Denmark	0.20	0.50	0.90	1.50
Germany	0.00	0.15	0.90	1.50
Ireland	0.15	0.63	0.90	3.00
New Zealand	0.00	0.20	0.60	1.00
Spain	0.00	0.15	0.85	1.00
UK	0.15	0.63	0.90	1.75

Table 2.2: International HVRT requirements under symmetrical faults [7].

Country	During Swell	
	V_{\max} (p.u)	T_{\max} (s)
Australia	1.30	0.06
Denmark	1.20	0.10
Germany	1.20	0.10
Spain	1.30	0.25

2.2.2 Active and Reactive Power Response under Disturbances

Stringent grid code requirements are in place in countries with large penetration levels of wind power and weakly interconnected networks. These requirements are specified to ensure that the WPP assists with system stability during various forms of disturbances on the grid. Active power response is required by WPPs to maintain the networks short-term frequency stability. Reactive power response on the other hand is required to assist with voltage stability within the network.

The South African grid code states that for symmetrical fault sequences, as illustrated in areas B and D in Figure 2.2, the WPP must possess the capability of providing and controlling reactive power as illustrated in Figure 2.4. The WPP must remain connected to the grid and provide normal power production as illustrated in the continuous operating region defined by area A in Figure 2.4.

Area B corresponds to a disturbance resulting in reduced voltage at the PCC. In this instance, the WPP is required to provide voltage support by supplying a controlled amount of reactive current to assist in stabilising the grid voltage. Area D corresponds to an overvoltage condition on the grid as illustrated in Figure 2.2 and Figure 2.4. In this case, the WPP is required to support by absorbing a controlled amount of reactive current. The absorption of reactive current (within the design capability of the WPP) would help stabilise the grid voltage. In the event of the voltage at the PCC dropping below 20%, the WPP will be required to continue to supply full reactive current within its design limitations to assist in stabilisation of the network voltage [9].

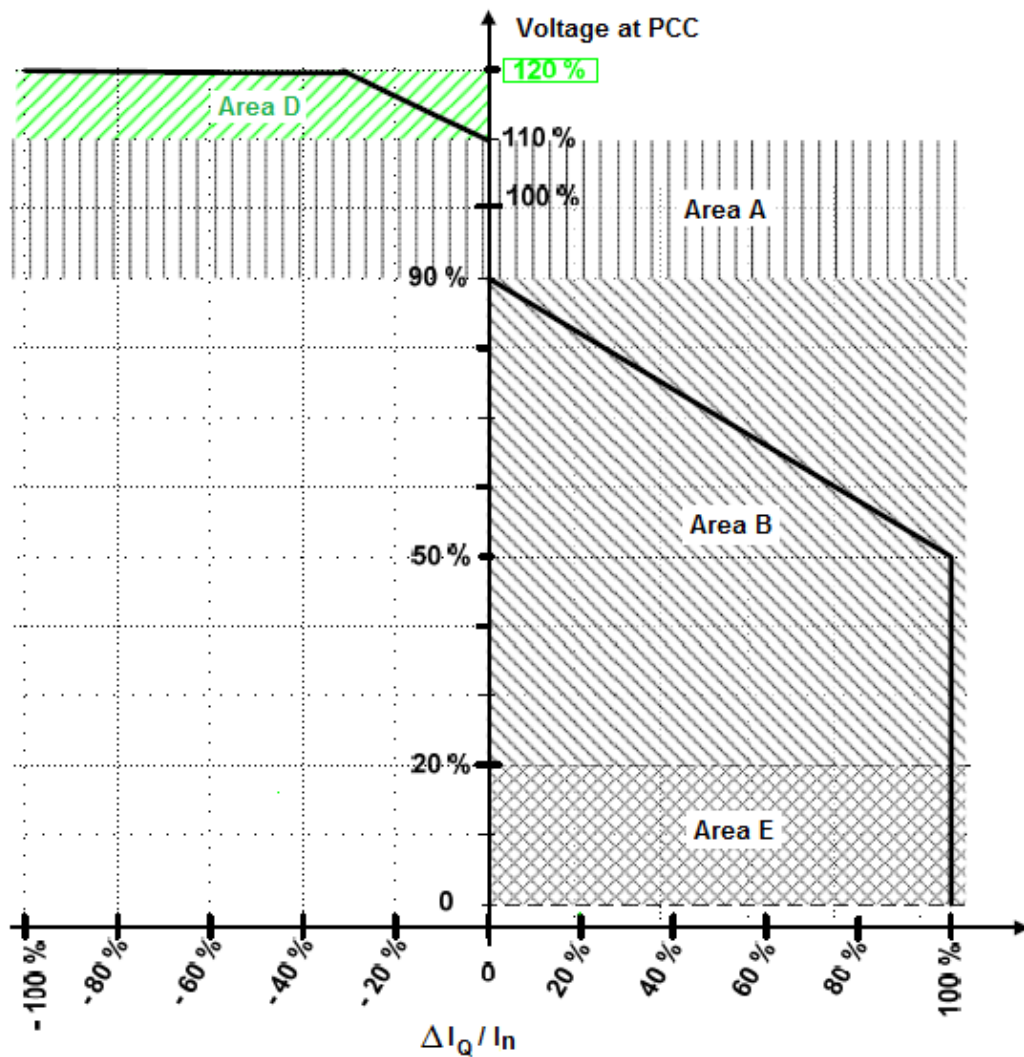

Figure 2.4: Reactive power support in the grid code for SA [9].

The Australian grid code requires their WPPs to provide capacitive reactive current of 4% of their maximum continuous current for each percentage reduction of the PCC voltage below 90% [7]. This would then result in the WPP providing a maximum reactive current at a voltage of 0.75 p.u at the PCC. The German grid code specifies a reactive current of at least 2% of the rated current for each percent of a voltage dip as illustrated in Figure 2.5 below. It also specifies a reactive power output of at least 100% of the rated power if necessary [11].

The Irish grid code specifies a reactive current response that will attempt to control the voltage at the PCC back to the nominal voltage where the magnitude of the reactive current is at least proportional to the voltage dip. It also specifies a rise time of 100 ms and a settling time of 300 ms for the reactive current response [10].

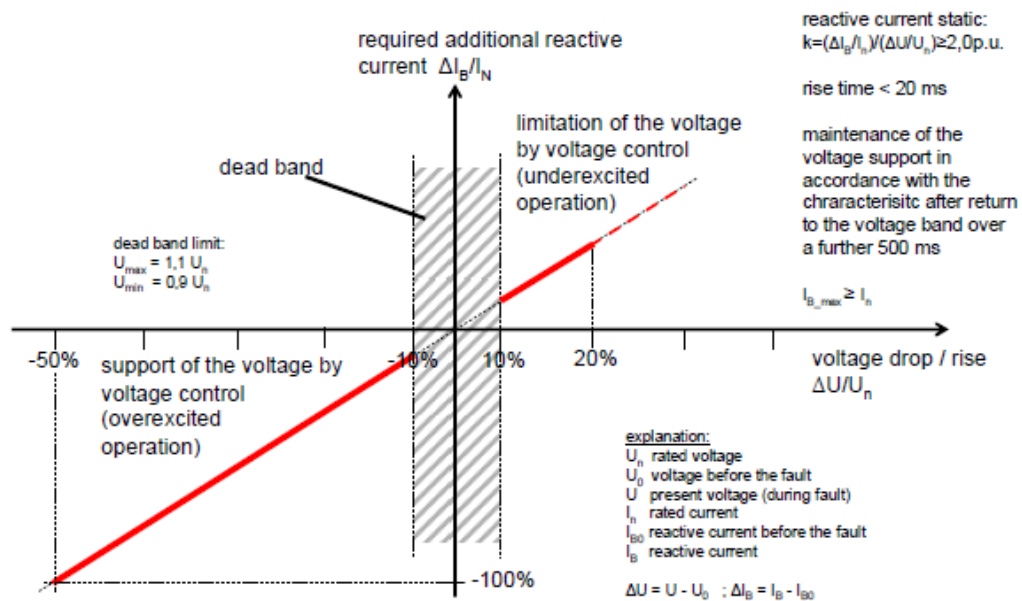

Figure 2.5: Reactive power support for the German grid code [11].

Grid codes also define requirements for the active power recovery for post fault conditions. The Irish grid code specifies that the WPP must continue the supply of active power in proportion to the retained voltage while providing reactive current to the transmission system. The code also specifies that the supply of reactive current shall continue until the voltage recovers to the normal operating range. The active power output must restore to 90% within 500 ms of the supply voltage reaching 0.9 p.u [10]. The German grid code specifies that the active power output must be continued immediately after fault clearance to its original value with a gradient of at least 20% of the rated power per second [11].

2.2.3 Extended Range of Frequency-Voltage Variations

Grid codes for WPPs also specify continuous generating ranges for frequency and voltage. The South African grid code specifies two separate normal operating voltages based on the WPP category. It specifies that a category A WPP shall be capable of operating within the range of -15% to 10% around the nominal voltage at the PCC while a category B and C WPP must be capable of operating in a range of $\pm 10\%$ around the nominal voltage. The WPP must also be capable of operating within a defined frequency range as illustrated in Figure 2.6 (a) and (b) for the life of the WPP and during a disturbance respectively [9].

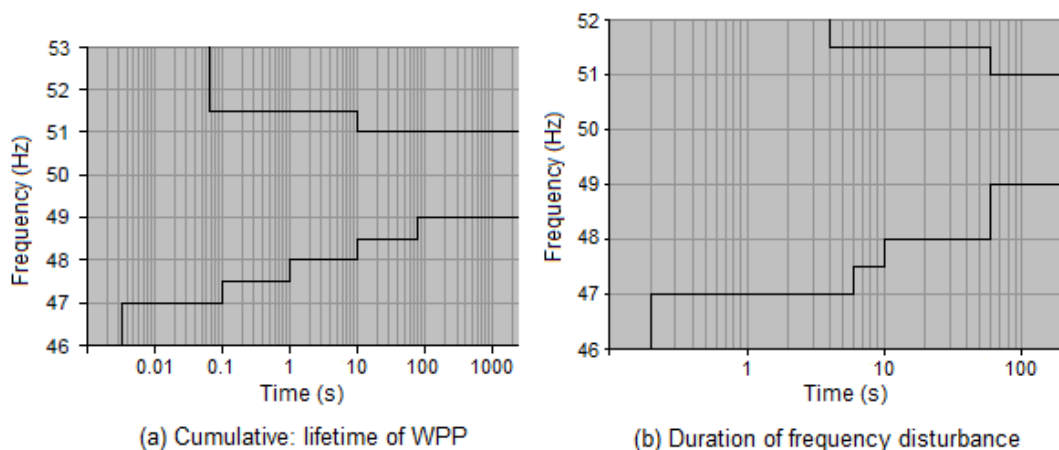

Figure 2.6: South African frequency operating range (a) Cumulative over the life of WPP. (b) During a frequency disturbance [9].

Table 2.3 presents the frequency limit specifications from some international grid codes. The grid code with the highest transient frequency deviation is that of the Canadian code. This code allows for a frequency deviation of 7.5% for a duration of 350 ms. The South African code allows for a maximum deviation of 8% for 200 ms. The UK has the largest continuous frequency range of 9% compared to that of South Africa of 4%.

Table 2.3: Frequency limits in international grid codes [7].

Country	Frequency (min) (Hz)	Frequency (max) (Hz)	Duration
Australia	49.5	50.5	continuous
	49.0	51.0	10 min
	48.0	51.0	2 min
	47.5	52.0	9 s
Canada	59.4	60.6	continuous
	58.5	61.5	11 min
	57.5	61.7	1.5 min
	57.0	61.7	10 s
	56.5	61.7	2 s
	55.5	61.7	0.35 s
Denmark	48.5	51.0	continuous
	48.0	51.0	25 min
	47.5	52.0	5 min
	47.0	52.0	10 s
Germany	49.0	50.2	continuous
	48.5	51.5	30 min
	47.5	51.5	10 min
	46.5	53.5	10 s
Ireland	49.5	50.5	continuous
	47.5	52.0	60 min
	47.0	52.0	20 s
UK	47.5	52.0	continuous
	47.0	52.0	20 s

2.2.4 Active Power Control and Frequency Regulation

International grid codes also contain specifications for active power control in order to achieve frequency regulation support to the system operator. Active power control is the ability of the WPP to adjust its active power output with respect to frequency deviations on the grid. WPPs are required to participate in primary and secondary frequency control [8]. Active power production is often curtailed during an increase in frequency in an effort to help regain the balance between power generation and consumption. Curtailment is often performed through the shutting down of some WPPs or through pitch control of the wind turbine blades. The South Africa grid code provides separate active power specifications for WPPs of category A and category B/C. The requirement for active power control in the South African grid code for category B and C WPPs is illustrated in Figure 2.7. The frequencies f_1 to f_4 forms a dead band and a control band in order to provide the primary frequency response whereas the frequencies f_4 to f_6 provides the mandatory critical power/frequency response. The droop settings are typically set between 0% and 10% in agreement with the state operator [9].

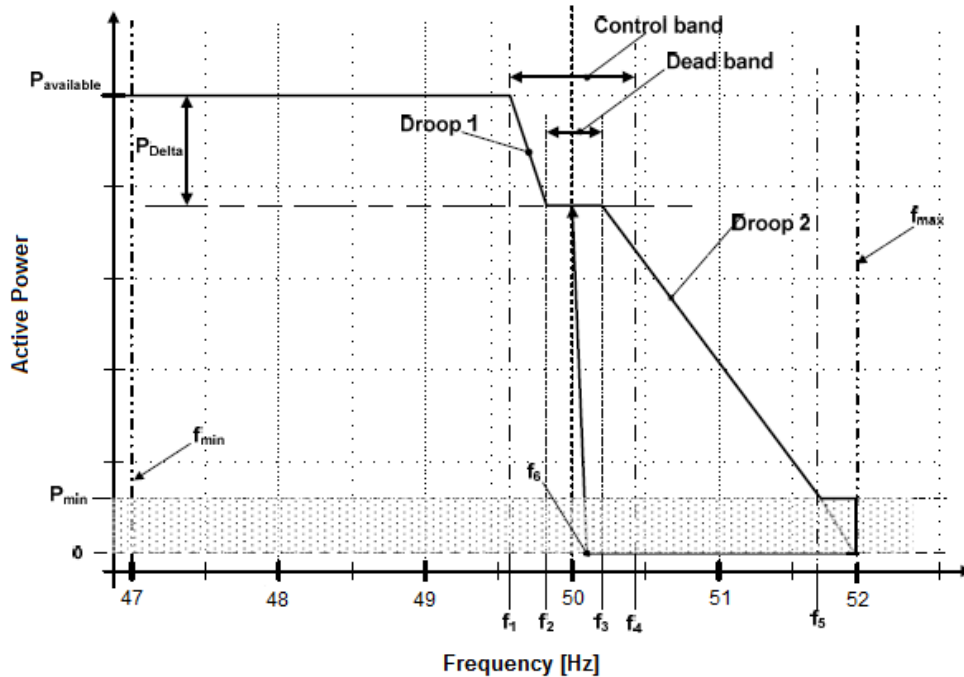

Figure 2.7: Active power requirements for category B & C WPPs in SA [9].

The Danish grid code has recommended three constraint functions to supplement active power production as illustrated in Figure 2.8:

1. Absolute production constraint.
2. Delta production constraint.
3. Power gradient constraint.

These constraint functions are used to avoid imbalances or overloading the supply network. The absolute production constraint function is used to limit the active power from a WPP in order to protect the network. In the delta production constraint function, the active power is limited to a value proportional to the available active power of the generator. The reserve power is then available to perform frequency control in the event of frequency deviations. In the power gradient constraint function, the rate of change of active power is limited in the event of changes in the wind speed or set points of the WPP. The power gradient constraint function is typically used for the purposes of maintaining system stability in the event of undesirable rate of changes in active power [12].

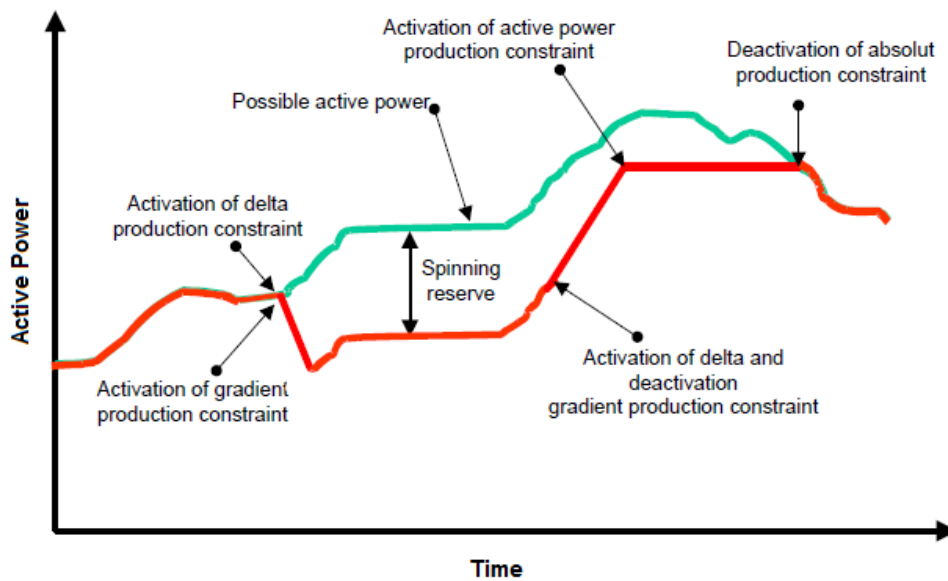

Figure 2.8: Danish active power constraint functions [12].

2.2.5 Reactive Power Control and Voltage Regulation

Many grid codes internationally stipulate WPPs to provide reactive power to enable voltage regulation to the supply network. The South African grid code provides separate specifications for reactive power output for voltage regulation where the actual operating point is agreed between the WPP and the national service provider. The specifications require a power factor ranging between 0.95 lagging and 0.95 leading and must be available from 20% of the rated power measured at the PCC [9]. The active/reactive power requirements for a category C WPP in the South African grid code is illustrated in Figure 2.9 below where the WPP can operate anywhere in the hatched area.

The voltage support specification in the South African grid code is illustrated in Figure 2.10 and clearly illustrates the need for reactive power supply in the event of voltage drop and reactive power absorption in the event of a voltage rise. The WPP can also be allowed to operate anywhere inside the hatched area as with the active/reactive power requirements.

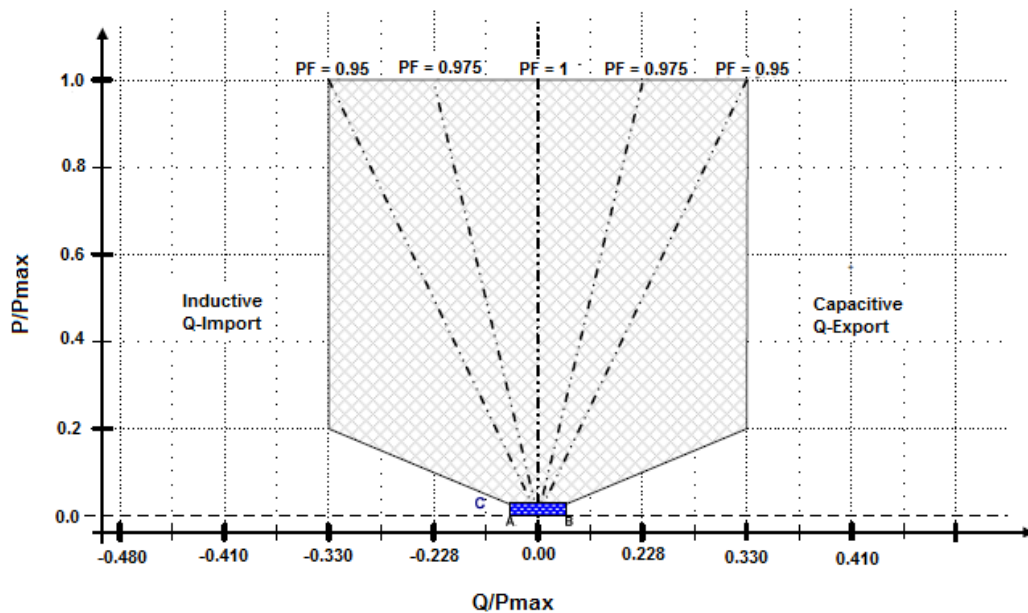

Figure 2.9: Active/reactive power requirements for category C WPPs in SA [9].

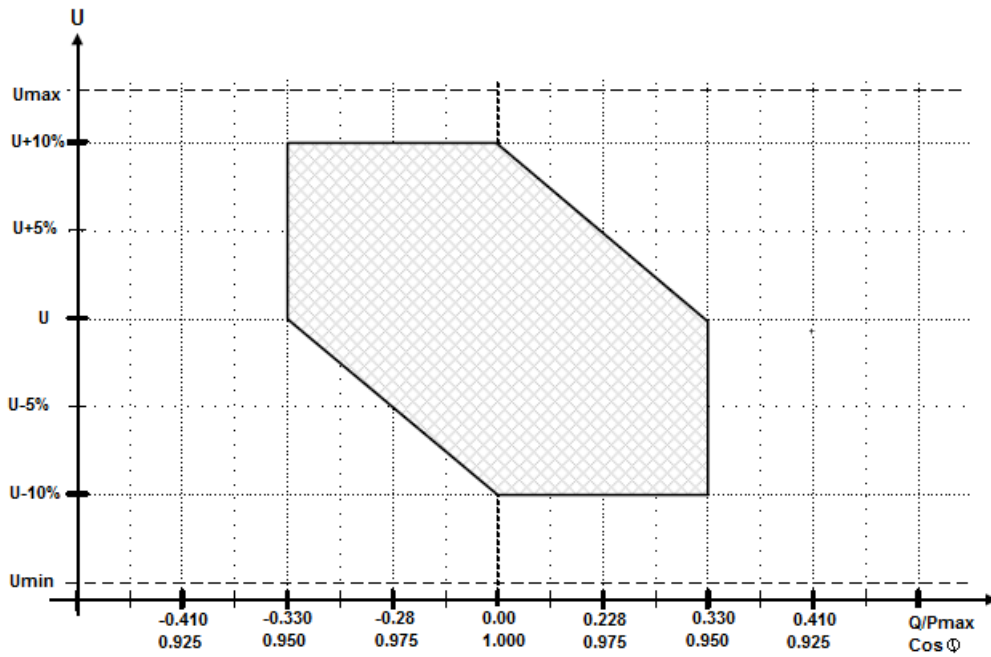

Figure 2.10: Voltage support requirements for category C WPPs in SA [9].

The limits for the power factor range in grid codes for countries with provisions for wind energy is presented in Table 2.4 below. The actual power factor operating range is dependent on the voltage at the PCC as illustrated in Figure 2.10 above.

Table 2.4: Power factor limit specifications for international grid codes [7].

Country	Power Factor	
	Capacitive	Inductive
Australia	0.93	0.93
Canada	0.90	0.95
Denmark	0.95	0.95
Germany	0.95	0.93
Ireland	0.95	0.95
New Zealand	0.95	0.95
Spain	0.91	0.91
UK	0.95	0.95
USA	0.95	0.95

Chapter 3

Wind Turbine Technologies

The technology and type of wind turbine determines its ability and extent to which it can comply with various grid codes and forms the basis of this chapter. A review of existing wind turbine technologies as well as the state of the art in wind energy conversion systems (WECS) is presented. Four basic WECS types are presented: synchronous generators in fixed and limited variable speed operation, variable speed doubly fed induction generators (DFIG) employing partial scale power converters, and variable speed induction generators employing full scale power converters.

3.1 Technological Background

Since the early 1970s, the development of WECS has progressed rapidly and was accelerated by the technological advancements in power electronics and high growth rates in the wind energy market. Various new technologies have been emerging with the focus on cost reduction, improved efficiency and reliability. Wind turbine technologies can broadly be classified into two categories: fixed speed and variable speed wind turbines. Fixed speed wind turbines are considered to be primitive due to limitations in machine technology and power electronics at the time. Variable speed wind turbine technologies now dominate as they are able to track changes in wind speed thereby maintaining optimal power generation.

3.2 Fixed Speed WECS

Fixed speed wind conversion systems are characterised by squirrel cage induction generators (SCIG) that are connected directly to the grid via transformers and are commonly referred to as Type 1 generators. This concept was used by the Danish wind turbine manufacturers in the early 1980s due to its simplicity, reliability and low cost and was commonly referred to as the ‘Danish concept’ [13]. In fixed speed wind turbines, the turbine speed is determined by the grid frequency, generator pole pair number, machine slip and gearbox ratios. Changes in wind speed will not affect the turbine speed to a large extent but has an impact on the electromagnetic torque and hence, electrical output power. Due to the use of induction generators, a speed variation of approximately 2% is normally achieved. Power is limited aerodynamically by either stall, active stall or pitch control [14]. A disadvantage of fixed speed WECS is its requirement for reactive power in order to establish a magnetic field. Reactive power compensation devices are therefore installed to fulfil the SCIGs reactive power requirements. Soft starters are usually installed to limit the inrush currents during start-up. Figure 3.1 illustrates a fixed speed WECS using a SCIG, a reactive compensator and a soft starter. Another disadvantage of this type of WECS is the need for a multiple stage gearbox which requires regular maintenance, reduces efficiency and generates audible noise.

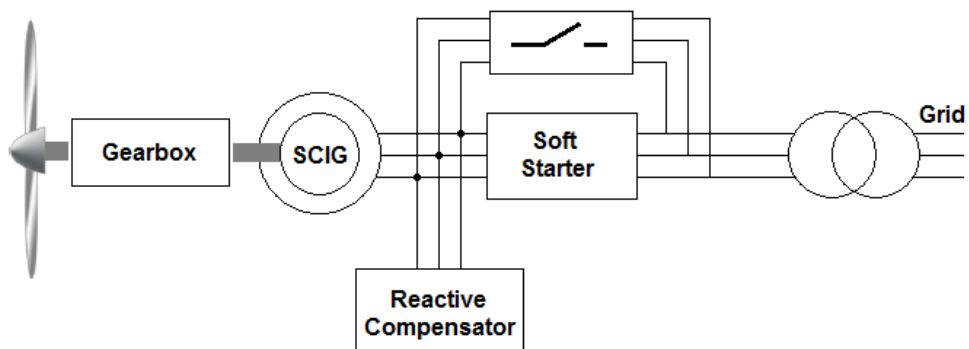

Figure 3.1: Fixed speed wind power generator with a SCIG.

A wound rotor induction generator (WRIG) can also be used in a wind power generator under the classification of ‘limited variable speed concept’. This concept is referred to as the Optislip concept and has been applied by Danish manufacturers since mid-1990s [13]. This type of WECS is commonly referred to as Type 2 generators. It consists of a WRIG with its rotor connected to an electronically controlled variable resistor bank as illustrated in Figure 3.2 below. The remaining structure of the system is similar to that of the fixed speed generator with SCIG as illustrated in Figure 3.1. In this WECS concept, a limited turbine speed range above synchronous speed is allowed. The speed range is however limited by the power ratings of the resistors used in the electronically controlled variable resistor bank. Operating at higher slips implies higher power to be extracted from the rotor and in turn, lower generator efficiency. The typical speed range of Type 2 generators is less than 10% above synchronous speed [13]. A disadvantage of this concept is the use of slip rings for the electronically controlled variable resistor bank. The other disadvantages are the need for reactive compensation and soft starters as for the fixed speed generator adopting the SCIG [15].

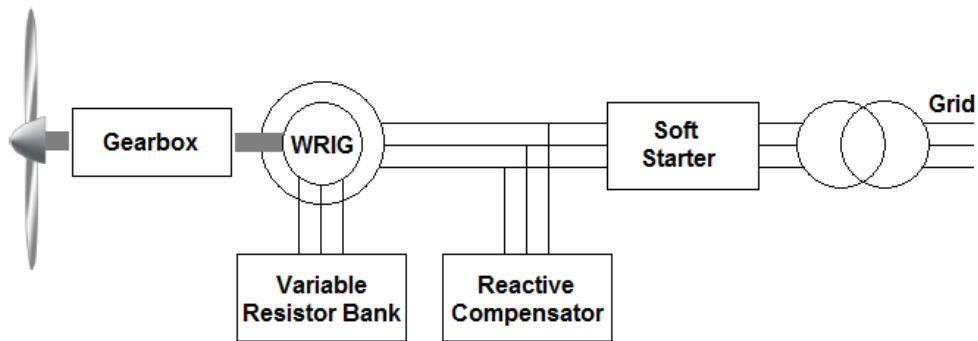

Figure 3.2: Limited speed range wind power generator adopting a WRIG.

3.3 Variable Speed WECS

Variable speed wind energy systems have the capability to store the varying incoming wind power by varying the speed of the wind turbine. In this way, the mechanical stresses in the wind turbine structure are reduced which result in a smoother delivery of electrical power into the grid [14]. In order to capture the maximum power possible, the maximum power point tracking (MPPT) control is employed for variable speed turbines. Various MPPT control techniques have been developed over the past decade [16]:

1. Optimum tip speed ratio (TSR).
2. Power feedback control.
3. Hill climb searching (HCS).
4. Fuzzy logic control.
5. Neural networks.

Variable speed wind power generators are generally classified into two categories: generators with full scale power converters and generators with partially rated power converters. Variable WECSs can either employ induction generators or synchronous generators. The conventional power generation industry prefers synchronous generators over induction generators as they have the advantage of variable reactive power production for voltage control. Synchronous generators are more dominant in stand-alone WECSs where it can be used for reactive power control within the isolated network. Induction generators are more popular in modern WECSs due to their advantages over synchronous generators. These advantages include brushless and rugged construction, low cost, low maintenance, operational simplicity, self-protection against faults, good dynamic response and most importantly, the capability to generate power at varying speeds [14].

3.3.1 DFIG with Partial Rated Converter

Figure 3.3 shows the scheme of the variable speed WECS employing the DFIG. This type of WECS is commonly referred to as a Type 3 generator. The partially rated back-to-back power electronic converter is connected between the rotor and the grid via slip rings and a transformer respectively. The stator is connected to the grid via a transformer. A crowbar circuit is connected in parallel to the rotor circuit in order to protect the rotor side converter (RSC) during grid faults. This topology of WECS can generate power at a speed range of 60% around synchronous speed with a power converter rating of 25% to 30% of the rated power of the WECS [17]. In super-synchronous operation, the electrical power is delivered to the grid via the rotor and the stator. In sub-synchronous operation, the electrical power is only delivered to the grid via the stator. The turbine speed is controlled to optimally extract power from the wind by controlling the active power from the RSC along with the various MPPT control techniques. The disadvantage of this WECS is the required maintenance for the slip rings and brushes that result in electrical losses and mechanical failures. Another disadvantage of this scheme is its sensitivity to grid faults. The DFIGs stator flux cannot follow the sudden change in stator voltage and this results in a DC component in the stator flux [18]. Consequently, the control strategies for fault ride-through are often complex and cumbersome and are presented in Chapter 4.2.

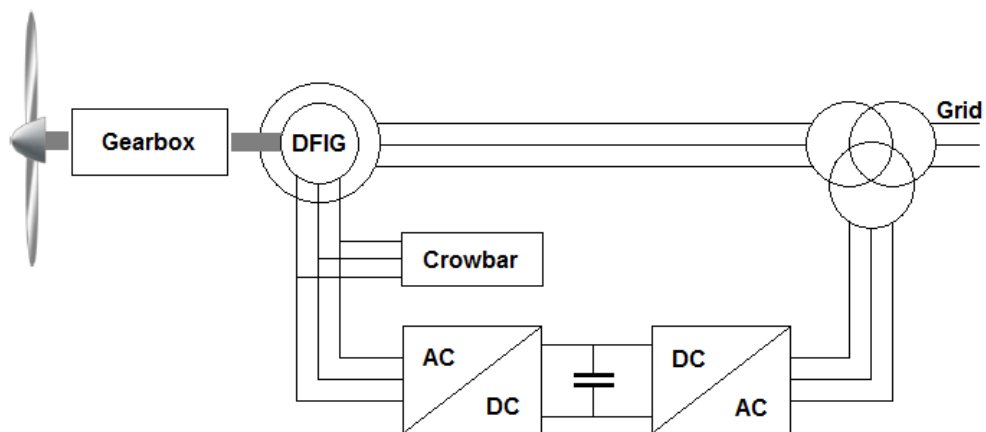

Figure 3.3: Variable speed WECS adopting a DFIG and partially rated converter.

3.3.2 SCIG with Full Scale Converter

The SCIG provides several advantages over the DFIG, namely, simplicity in structure, cost effectiveness and reduced maintenance requirements as discussed in Chapter 3.2. The fixed speed WECS concept presented in Figure 3.1 was expanded to a variable speed concept with the addition of a full scale back-to-back power electronic converter as illustrated in Figure 3.4. This type of WECS employing a full scale converter is commonly referred to as a Type 4 generator. The generator torque and consequently its speed is controlled by the machine side converter (MSC) with the aid of various MPPT control schemes. The grid side converter (GSC) is responsible for the control of the DC link voltage and active/reactive power flow into the grid.

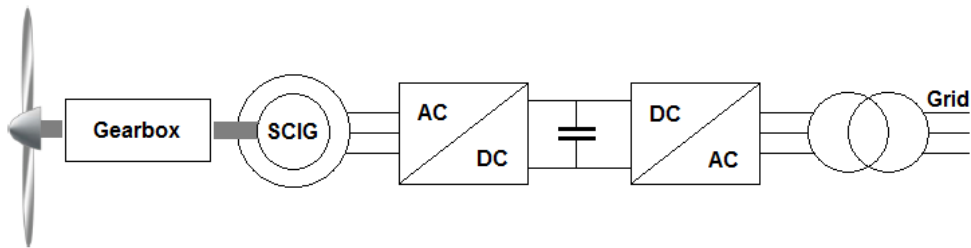

Figure 3.4: Variable speed WECS adopting a SCIG and full scale converter.

3.3.3 SG with Full Scale Converter

Variable speed WECSs employing SGs in the form of electrically excited synchronous generators (EESG) and permanent magnet synchronous generators (PMSG) is illustrated in Figure 3.5 and Figure 3.6 respectively. The use of a multiple stage gearbox can reduce the volume and weight of the SG when compared to the direct drive systems while further reducing designing and manufacturing difficulties.

The use of a multiple stage gearbox in a high speed WECS also results in unavoidable power losses and poses serious maintenance difficulties particularly in offshore wind farms. The rule of thumb is that 1% of the total power applied at the input shaft is lost for each stage in a multistage gearbox [19]. The use of direct drive WECSs has achieved increasing acceptance in recent years due to their high efficiency, high reliability and reduced maintenance requirements [15]. The WECS in Figure 3.5 and Figure 3.6 can also be implemented in direct drive schemes. The EESG consists of a rotor that generates the DC excitation to the generator. The generator requires a high number of poles to compensate for the reduction in generator speed due to the absence of a gearbox. Consequently, the mass of the generator is greater than that of a generator employing a multistage gearbox. The use of slip rings and brushes are necessary for both multistage and direct drive EESG configurations. PMSG technology is often preferred over EESG technology due to its advantages of high efficiency and robust structure. The disadvantage of the PMSG is its higher costs due to expensive permanent magnet materials [15].

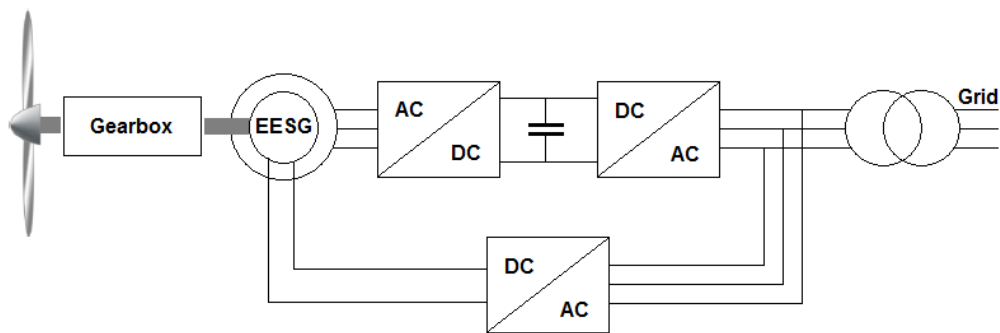

Figure 3.5: Variable speed WECS adopting an EESG and full scale converter.

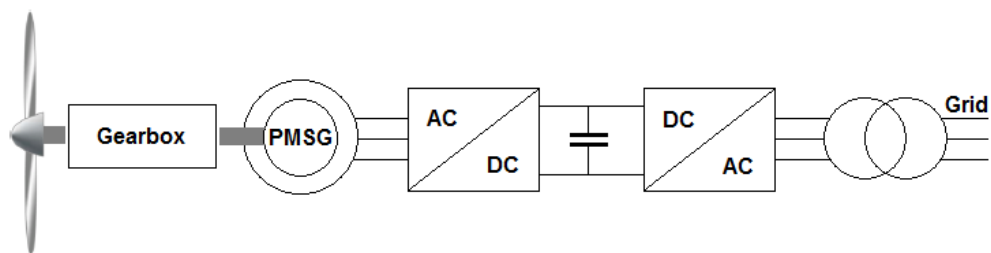

Figure 3.6: Variable speed WECS adopting a PMSG and full scale converter.

Chapter 4

Grid Compliance Technologies

This chapter reviews some of the latest grid code compliance technologies for variable speed wind power generation systems. The compliance technologies discussed will focus on the DFIG and full scale converter type generator topologies as these are the most popular. The control of the power electronic converters for the above wind turbine topologies will form the basis of the discussion as it is central to the research and addresses the fourth research question. The control schemes for the following grid code requirements will be discussed: fault ride-through capability, reactive power support and frequency control.

4.1 Background

With the increase in penetration levels of wind energy, WPPs are now required to contribute to power system stability and operability via country specific grid codes. The ability of a wind power generator to comply with the most international grid code specifications depends on the topology of the generator and the technology used in the control of its power electronic converters. These grid codes basically require WPPs to exhibit conventional power plant like characteristics. The most common requirements are the LVRT capabilities, active/reactive power support and frequency regulation.

4.2 Fault Ride-Through Control

The fault ride-through capability of a wind power generator is one of the most important yet demanding characteristics with regard to grid code compliance. It requires the generator to remain connected to the grid in the event of a grid fault and contribute to grid stability by supplying reactive power during the fault event as described in Chapter 2.2.2. The fixed speed and limited variable speed WECS described in Chapter 3.2 suffers little risk from grid faults as these topologies do not employ power electronic converters. During a fault, the electromagnetic torque within the machine reduces proportionally to the square of the remnant voltage [7]. As a result of the reduction in the electromagnetic torque, the turbine can accelerate beyond its safety limits, the active power output decreases and the reactive power requirement increases. These wind turbine topologies are therefore unsatisfactory with regard to fault ride-through capability.

The DFIG variable speed WECS described in Chapter 3.3.1 provides limited fault ride-through capabilities due to the stator being directly connected to the grid and the stator and rotor being magnetically coupled. A grid fault in the form of a voltage sag at the PCC results in high inrush currents in the stator which in turn causes overcurrents in the semiconductor devices within the RSC [7]. Overvoltage in the DC-link can also occur due to excessive wind energy input that is unable to be transferred into the grid during grid faults. Various active and passive control methods are available to improve fault ride-through capabilities in DFIG based WECS.

Conventional passive methods commonly used are [20]:

1. Pitch angle control.
2. Crowbar methods.
3. Energy capacitor systems (ECS) or DC capacitor sizing.
4. Energy storage systems (ESS) or DC bus energy storage.

Active control methods discussed below involve advanced converter control schemes in order to improve fault ride-through capabilities. WECSs with fully rated converters as presented in Chapter 3.3.2 and Chapter 3.3.3 have better fault ride-through capabilities when compared to the DFIG type due to the grid being completely decoupled from the generator via back-to-back power electronic converters. The control schemes in these topologies of wind turbines only have to ensure stability of the DC link voltage due to the imbalance of input and output power in the event of a grid fault.

4.2.1 DFIG Control by Temporary Increase of Rotor Speed

Two advanced control schemes proposed in [21] help enhance the LVRT capability of a DFIG based wind turbine. One control scheme is proposed for the RSC and the other for the GSC. The RSC control scheme transforms the imbalanced power generated in the event of a grid fault to kinetic energy by temporarily increasing the generators rotor speed. This kinetic energy can slowly be released into the grid after the fault is cleared. The imbalanced power would normally be dissipated in the crowbar as illustrated in Figure 3.3. The GSC control scheme introduces a compensation term that reflects the instantaneous DC link current of the RSC in order to stabilise the DC link voltage in the event of a grid fault. This protects the power electronic converters against current and voltage fluctuations which ensures that the wind turbine remains connected to the grid. The proposed control schemes do not require any additional components, e.g. crowbars, and only utilises the existing resources within the wind turbine.

The two proposed control strategies ensure controllability of the power electronic converters and the wind turbine during grid faults as well as support for active and reactive power. Figure 4.1 and Figure 4.2 illustrate the control scheme for the RSC and GSC respectively.

(a) Control of the RSC

The control scheme block diagram for the RSC is illustrated in Figure 4.1 below. The main function of the RSC is to control the stator side active and reactive power separately. The induction generator is controlled in the stator flux orientated reference frame which enables the electromagnetic torque to be decoupled from the rotor excitation current. Proportional-integral (PI) controllers are used with the following inputs: rotor currents i_{dr} and i_{qr} , reactive power in stator Q_s , actual rotor speed ω_r and reference rotor speed ω_r^* generated by the generator MPPT controller. The reference rotor voltage in the d - q reference frame feeding the RSC is represented by v_{dr}^* and v_{qr}^* . The cross coupling terms represented by v_{dr1} and v_{qr2} are functions of the machines electrical and mechanical parameters.

A grid fault is identified by monitoring rotor currents, stator currents, DC link voltage and the grid voltage. If a valid grid fault is identified, the LVRT control strategy is triggered by setting the reference electromagnetic torque, T_{ref} to zero as illustrated in red in Figure 4.1. This will enable an increase in the generator speed thus allowing kinetic energy storage in the turbine blades. During operating speeds close to rated speed, a grid fault triggering the control scheme may accelerate the wind turbine beyond its rated speed and close to its mechanical limitations. In this event, standard pitch control schemes can be used to restrain the speed of the wind turbine.

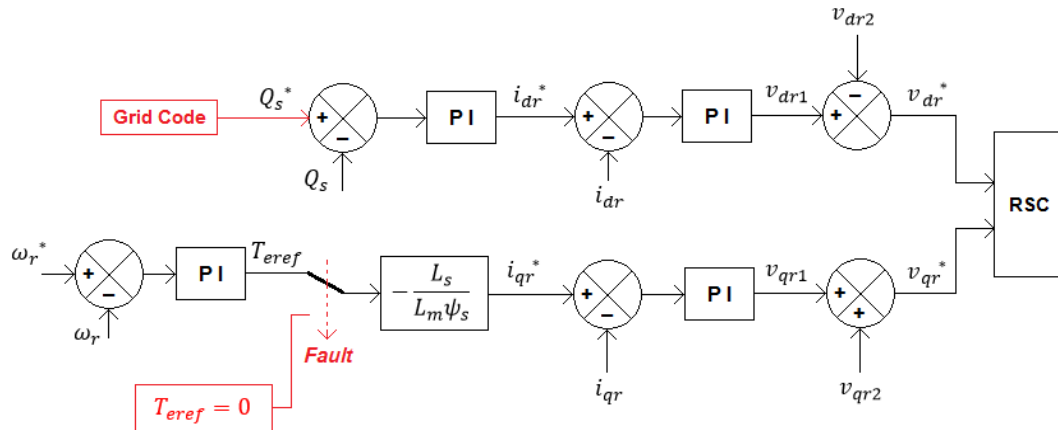

Figure 4.1: Control scheme of the RSC for normal and fault operation [21].

(b) Control of the GSC

The control scheme block diagram for the GSC is illustrated in Figure 4.2 below. The purpose of the GSC is to maintain a constant DC link voltage regardless of the direction of power flow within the rotor. The GSC operates in the grid voltage oriented reference frame with its d -axis oriented along the grid voltage vector. This enables independent control of the active and reactive power flowing between the GSC and the grid itself. The actual DC link voltage is compared to the reference value, V_{DC}^* to form an error signal that is used for calculating the reference d -component GSC voltage, v_{dg}^* . The reference q -component of the grid current (representing the reference reactive power, Q^*) is compared to the actual q -component of the grid current to form an error signal that is used in calculating the reference q -component for the GSC voltage, v_{qg}^* . In normal turbine operation, the DC current in the rotor converter, i_{or} and the grid converter, i_{os} are equal thus maintaining a constant DC link voltage where:

$$i_{or} = \frac{P_r}{V_{DC}} \quad (\text{eq. 1})$$

P_r is the magnitude of the active power of the rotor and V_{DC} is the DC link voltage. In the event of a grid voltage sag, i_{or} represented as a disturbance is added to the control scheme as illustrated in red in Figure 4.2 below. This term is added to the grid converter DC current component, i_{os} to compensate for the instantaneous rotor power and as a result, the DC link voltage is stabilised.

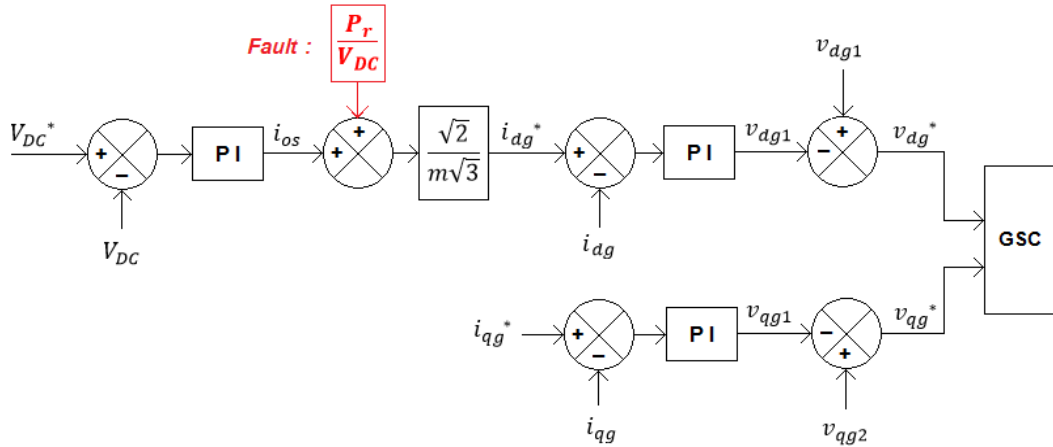

Figure 4.2: Control scheme of the GSC for normal and fault operation [21].

4.2.2 DFIG with DC Link Chopper

Many of the initial DFIG based wind turbines made use of the crowbar in order to protect its RSC and DC link capacitor in the event of grid faults. This is achieved by connecting a three phase resistance in parallel with the rotor windings thus bypassing the RSC and DC link [22]. In the event of grid faults, the crowbar is activated and the RSC deactivated. The generator then resembles a singly fed wound rotor induction generator absorbing reactive power from the grid and thus negatively contributing to the grid fault. The crowbar protection scheme works well in protecting the generator itself but does not provide favourable grid support in the event of grid faults. The reason for this is that when the crowbar is activated, the RSC loses total control of the generator and reactive power supply from the stator to the grid is lost as a result. As the supply of reactive power is lost during grid faults due to the activation of the crowbar, LVRT grid code requirements, as described in Chapter 2.2.2, cannot be fulfilled.

A DC link chopper within the DC link of the DFIG as illustrated in Figure 4.3 offers an alternative solution to the crowbar protection scheme. The RSC is designed to handle the maximum surge current from the rotor during a grid fault and as a result, the RSC maintains control of the generator. This enables the generation of reactive power during a fault as per grid code requirements.

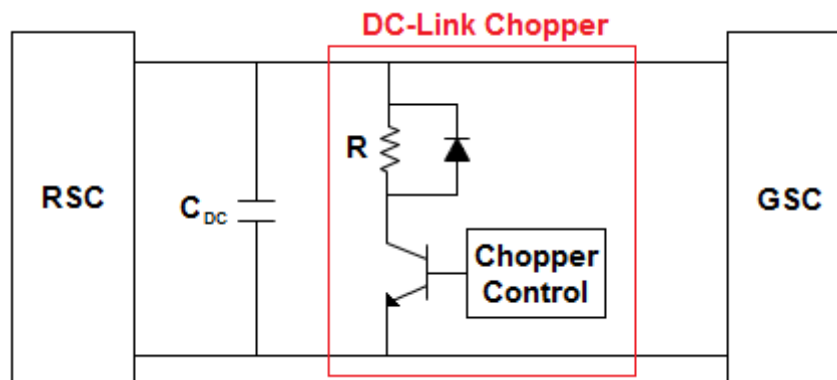

Figure 4.3: DC link of DFIG wind turbine with DC link chopper.

The chopper resistance, R is switched by the chopper control in order to maintain the DC link voltage within specified limits and the GSC assists in this regard [23]. The control scheme for the DC link chopper is usually a hysteresis based controller with DC link voltage limits set between 1.1 p.u and 1.2 p.u [24]. The use of a DC link chopper in modern DFIGs has the following advantages over the use of the traditional crowbar:

1. Control of the RSC is possible during grid faults and as a result, reactive power can be supplied to the grid during and after the fault. This is a requirement in most grid codes and cannot be fulfilled with the use of a crowbar.
2. The DC link chopper protects the DC link capacitor and converter power electronics from dangerous overvoltages during grid faults.
3. Vector control over the generator is achieved during a fault as the RSC still remains connected to the rotor. This is not possible with a crowbar.
4. The chopper protection scheme offers lower short-circuit current than the crowbar protection scheme under low initial loading conditions [25].
5. Torque oscillation damping in the generator is possible. This is not possible with a crowbar [24].

The penalty of using a DC link chopper is the additional cost of the overrated RSC required to handle the fault currents generated by the rotor during a fault. Crowbars are still installed in DFIGs as a backup protection system in the event of failure of the DC link chopper.

4.2.3 Hybrid Current Control of DFIG

The enhancement of various control schemes in order to improve fault ride-through capabilities often involves regulation of the rotor current in two opposite rotating frames. In order to achieve the regulation into two opposite rotating frames, modified PI current controllers are used. The PI current controllers are often tuned based on small signal analysis of the nonlinear DFIG characteristics and therefore have limited control bandwidth. In the event of a grid fault, the PI current controllers would not be able to handle the high frequency rotor currents and this could result in damage to the converters and disconnection of the wind turbine from the grid. In [26], a hybrid current controller is proposed to address the above disadvantage of the DFIG based wind turbine and improve its fault ride-through capability.

The proposed control scheme for the RSC comprises of two current regulators: a standard PI current regulator and a vector-based hysteresis current regulator (VBHCR) as illustrated in Figure 4.4. The standard PI current regulator is activated during normal operating conditions and optimally regulates the rotor currents. This type of current regulator is ideal for steady state operation due to its low switching frequency. In the event of grid faults, the PI current regulator provides unsatisfactory transient response for vector based control.

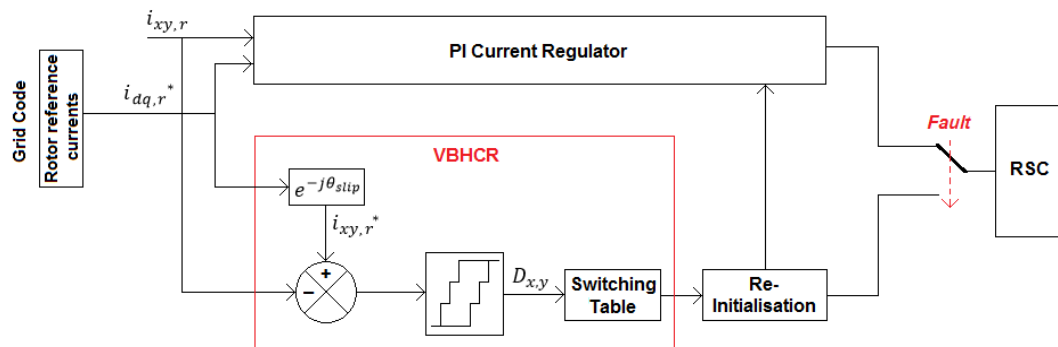

Figure 4.4: Control scheme of the proposed hybrid current regulator [26].

The VBHCR that exhibits fast transient response compared to the standard PI current regulator is activated under various fault conditions by the supervisory control system of the wind turbine. The re-initialisation unit functions to achieve a smooth transition between the two current regulators. The standard PI current regulator and the VBHCR both complement each other in the control of the RSC during steady state and fault conditions respectively.

Figure 4.5 illustrates the detail of the proposed VBHCR control scheme as shown in Figure 4.4. The rotor currents are defined in the x - y reference frame rotating at the rotor speed and the d - q reference frame rotating at the synchronous speed. The rotor current controller comprises of a four and three level hysteresis comparator for tracking the x and y error components of the rotor currents respectively. A switching table then uses the digital outputs from each hysteresis comparator, D_x and D_y to provide the vector output voltages for the RSC via a look-up table. This hysteresis based control scheme is robust to voltage distortions and other system parameter variations due to its reliance on only the instantaneous measurements of rotor currents [26]. The VBHCR thus provides fast transient response and eliminates high current oscillations in the rotor thereby enhancing the DFIGs fault ride-through capability.

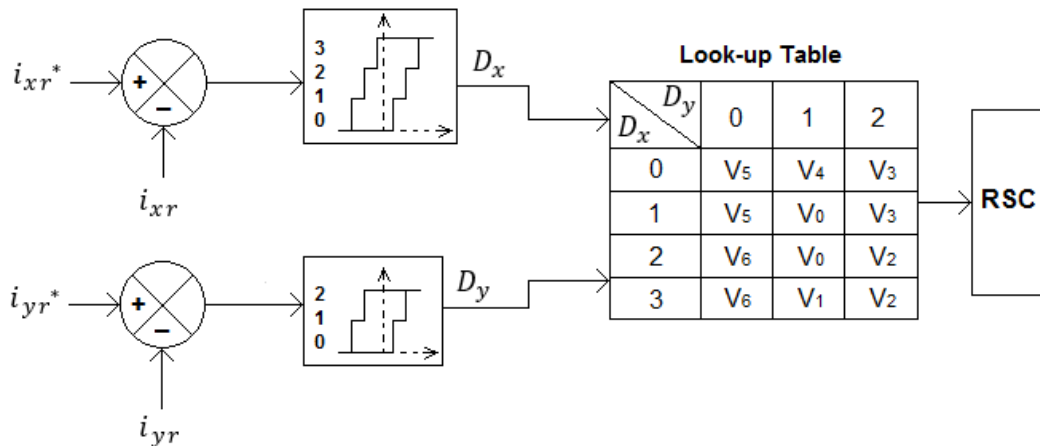

Figure 4.5: Practical implementation of the VBHCR [26].

4.2.4 Power Compensation Feedback in Full Scale Converters

Full scale converter wind power generator systems described in Chapter 3.3 possess better fault ride-through capabilities when compared to DFIG based generation systems. This is primarily due to the grid being decoupled from the generator through back-to-back full scale power electronic converters. One of the main challenges with full scale back-to-back power electronic converters during grid faults is the inability to control the DC link voltage. This inability arises due to the GSC not being able to return power from the DC link capacitor to the grid while power continues to be injected from the wind turbine into the DC link.

A DC link voltage control scheme which provides a power compensation signal to the MSC is proposed in [27]. The proposed scheme enables faster DC link voltage regulation by providing the MSC with a compensation power term, P_{comp} as illustrated in Figure 4.6. P_{comp} refers to the surplus power that is available from the wind turbine that cannot be handled by the GSC. The DC link voltage controller maintains the DC link voltage by controlling the q -component current of the GSC i.e. i_{qg}^* . Since P_{comp} is directly transferred to the MSC, the DC link voltage can be controlled by the MSC itself without intervention from the DC link voltage controller.

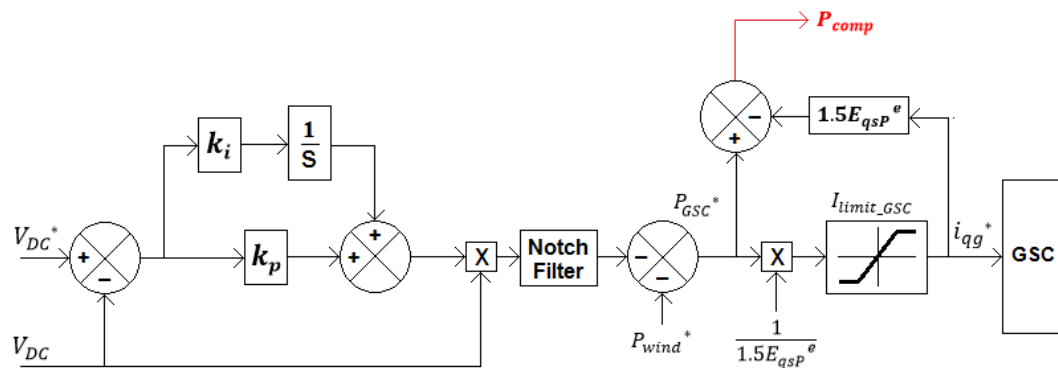

Figure 4.6: Proposed DC link voltage control scheme for full scale converter [27].

Figure 4.7 illustrates the use of the P_{comp} term in the MSC current reference generator within the MSC control scheme. The compensation power term is added to the reference wind power in order to generate the reference q -component current for the MSC, i_{qm}^* . In this proposed control scheme, the DC link voltage will be regulated even with reduced DC link capacitance.

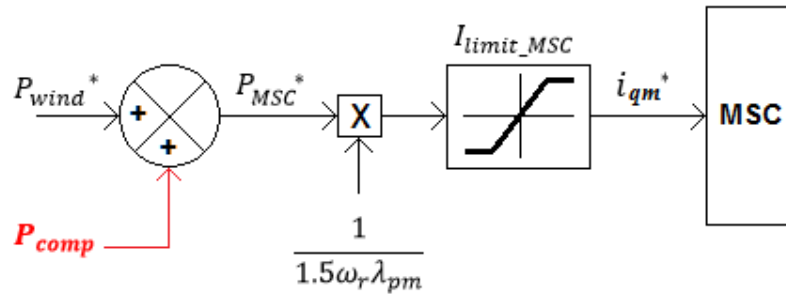

Figure 4.7: MSC current reference generator [27].

4.3 Reactive Power Control

Variable speed generator systems are the preferred choice over fixed speed generators systems with regard to reactive power and fault ride-through capabilities. This is primarily due to their superior decoupled controllability of active and reactive power through the various P - Q control schemes provided by their power electronic converters [7]. Reactive power capabilities are crucial in wind farms as this helps maintain network stability after various grid faults and network disturbances. Figure 4.1 presented an LVRT control scheme for a DFIG that is also able to independently control reactive power via the d -component of rotor current and voltages. This control scheme was also presented in [28] but without the LVRT enhancements on the RSC and GSC as proposed by [21].

The use of flexible AC transmission systems (FACTS) is proposed by [28] to resolve many of the major operating problems such as voltage regulation, power flow control, transient stability and power oscillation damping. The static synchronous compensator (STATCOM) and the static series synchronous compensator (SSSC) are able to provide DFIG based wind farms with dynamic power and voltage control. A STATCOM is commonly utilised in order to achieve smooth and rapid steady state transient voltage control at various PCCs within a network containing wind farms.

4.3.1 Control using the STATCOM

Figure 4.8 illustrates the control scheme for a STATCOM connected to the grid at the PCC with DFIG based wind farm. The STATCOM generates a set of balanced three-phase voltage waveforms at the fundamental frequency. The phase and amplitude of the output voltage waveforms are fully controllable by the STATCOM control scheme. The STATCOM itself is modelled by a gate turn-off (GTO) based PWM converter and a DC link. It provides a desired amount of reactive power or voltage support at the PCC to successfully ride-through various grid disturbances.

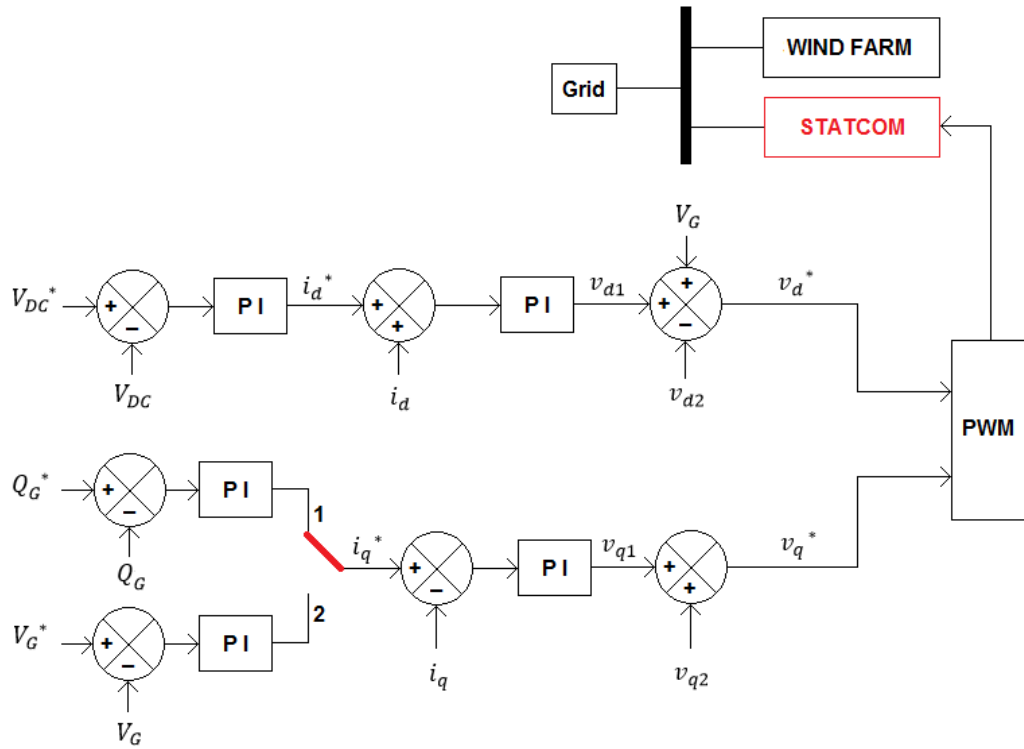

Figure 4.8: STATCOM control scheme for fault ride-through support [29].

The inputs to the STATCOM control scheme are the actual and reference values of the DC link voltage, the reactive power delivered by the STATCOM and the reference reactive power, Q_G and Q_G^* respectively, the actual and reference grid voltage and the d - q components of the STATCOM converter current. The reference d -component of the output voltage required by the STATCOM control scheme is derived from the difference between the actual and the reference DC link voltage. The reference q -component of the output voltage required from the STATCOM control scheme is calculated by either the difference between the reference and actual values of the reactive power or the difference between the reference and actual grid voltage. In this way, the STATCOM is capable of providing reactive power compensation or voltage regulation by simply switching between point 1 and 2 respectively as illustrated in Figure 4.8.

4.3.2 Coordinated Control using the Interface Neurocontroller

The use and control of the STATCOM described in Chapter 4.3.1 is totally independent of that of the wind farm and its controllers. In the event of various grid faults, voltage regulation and reactive power control is only realised by the STATCOM if the wind farm does not possess any active fault ride-through strategy and control. In [29], a coordinated control strategy is introduced between a DFIG based wind farm and a STATCOM. An interface neurocontroller (INC) is proposed to coordinate the reactive power output and control between the wind farm and the STATCOM as illustrated in Figure 4.9. The grid voltage deviation, ΔV_G and the active power deviation of the wind plant generated power, ΔP_{GEN} is fed into the INC. The INC then generates two supplementary control signals, ΔQ_{GEN} and ΔQ_{STAT} . A steady state fixed point value for the generator reactive power, $Q_{GEN,0}$ is added to the control signal ΔQ_{GEN} to provide the RSC reference control signal for reactive power, Q_{GEN}^* . A steady state fixed point value for the STATCOM reactive power, $Q_{STAT,0}$ is also added to the control signal ΔQ_{STAT} to provide the reference control signal for reactive power for the STATCOM, Q_{STAT}^* .

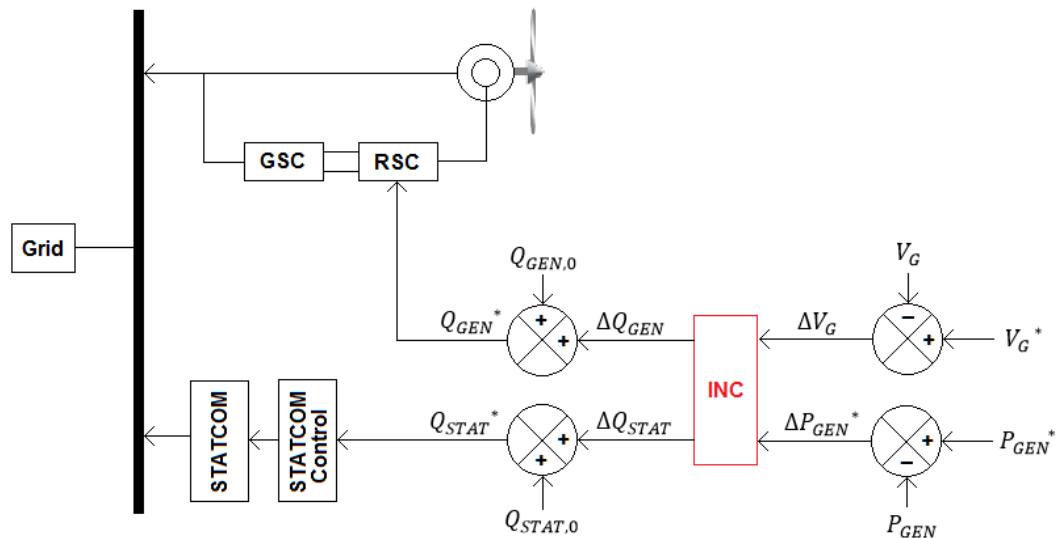

Figure 4.9: Coordinated control of STATCOM and wind farm using the INC [29].

The coordinated control of both the STATCOM and the generator allows for the rapid control of the reactive power generated by each of them and in this way, voltage sags appearing at the PCC can be rapidly reduced. This coordinated control effort also allows for the control of the mechanical power imbalances resulting from grid voltage sags. The grid voltage deviation, ΔV_G is used as an input to the INC due to the direct relationship between voltage and reactive power. The active power deviation, ΔP_{GEN} is also used as an input to the INC as it provides the electrical and mechanical dynamic characteristics of the generator. The steady state fixed point values for the wind plant is derived from the desired stator side power factor of the DFIG and its reactive power rating. The steady state fixed point values for the STATCOM is derived from a complex power flow analysis [29]. The INC transfer function from the deviation signals to the control signals is highly complex and nonlinear in nature and beyond the scope of this research. The following two techniques are used in the design of the INC namely Heuristic Dynamic Programming (HDP) and Radial Basis Function Neural Networks (RBFNN) [30].

4.4 Frequency Control

Grid frequencies are maintained if the generated power is balanced by the power that is consumed together with electrical losses within the power system. Frequency response to various grid disturbances can be classified into three categories: inertial response, primary frequency response and secondary frequency response or automatic generation control (AGC). Inertial response immediately follows a frequency disturbance while primary response occurs within a timeframe of 20 – 30 seconds. Secondary response occurs within a timeframe of 5 – 10 minutes [31]. Inertial response is determined by the mechanical properties of the generator. Primary response is responsible for stabilising the frequency disturbance and is normally performed by the generator governor control. The secondary response is responsible for the restoration of system frequency to the nominal value. This is normally achieved by generators adjusting their active power outputs in response to system operator demands.

4.4.1 Siemens Patent for Dynamic Power Output

US Patent [32] by Siemens proposes a control scheme by dynamically modifying the active power output of individual wind turbines within a wind farm in response to grid frequency disturbances. Figure 4.10 illustrates the embodiment of the power system and its control system acting on individual wind turbines within the wind farm. The controller is configured to adjust the active power output of the individual wind turbines within the wind farm. The monitor within the controller measures the deviation of grid frequency and instantaneous available wind power. Changes in wind power can be detected by changes in wind turbine shaft speed in full scale converter based wind turbines. The controller functions to adjust the active power output based on monitored correlation in order to satisfy applicable grid code frequency requirements.

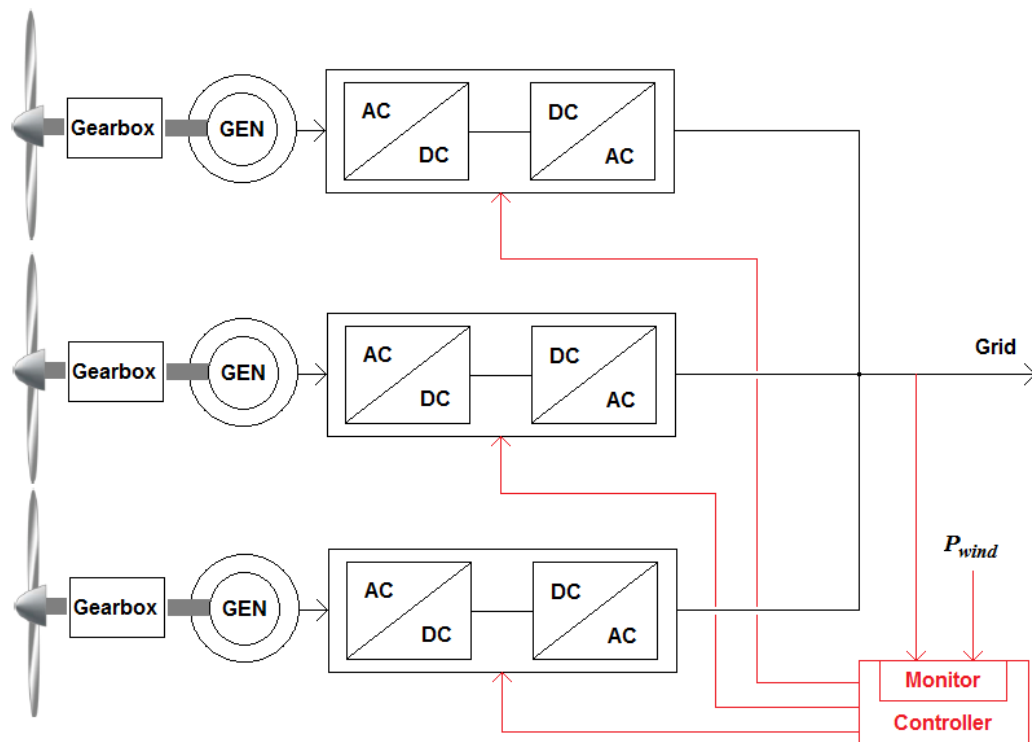

Figure 4.10: Individual active power modulation as patented by Siemens [32].

The patent proposes an innovative control technique where changes in the output power can be introduced by either delaying the power change or by gradually increasing/decreasing the power output to the desired value. This is proposed in order to avoid the negative effects on frequency regulation by such active power output changes. In instances of increased wind power and over-frequency on the grid, the increase in the WECS output power can be delayed or slowly ramped up. Similarly, the decrease in output power from the WECS can be delayed or slowly ramped down during periods of reduced wind power and under-frequency on the grid. Conversely, output power from the WECS can be effected immediately if the power change is conducive to grid code requirements. In this case of increased wind power and under-frequency on the grid, the output power from the WECS can be rapidly ramped up instead of being delayed or slowly ramped up. Similarly, in a case of decreased wind power and over-frequency on the grid, the output power from the WECS can be rapidly ramped down instead of being delayed or slowly ramped down.

4.4.2 VESTAS Patent for Power Curtailment

In [33], VESTAS presents a method of curtailing active power in a wind turbine or a wind farm that allows fast and effective frequency control in order to comply with the demands of various grid code requirements. The method of power curtailment comprises of the following steps:

1. Determining the available electrical power level from the wind turbine.
2. Setting a curtailment level that is independent of wind speed.
3. Operating the wind turbine such that the power supplied from the wind turbine equals the difference between the actual available electrical power and the curtailment level.

The curtailment of the electrical power from the wind turbine is defined under three embodiments within the patent. The wind turbine may be either isolated or form part of a wind farm.

Embodiment 1: The electrical power supplied by the wind turbine into the grid may be curtailed by pitch control of at least one rotor blade or a set thereof.

Embodiment 2: The electrical power supplied from the wind turbine may be curtailed by speed control of the rotor blades.

Embodiment 3: The electrical power supplied from the wind turbine may be curtailed by speed control of the rotor blades and pitch control of the rotor blades at predetermined angles.

Figure 4.11 illustrates the power curtailment control scheme for a DFIG. The main controller is responsible for the overall control functions of the wind turbine as well as the pitch and power control. The main controller receives a curtailment coefficient which is the ratio between the actual power generated and the power available from the wind. The main controller then calculates a pitch offset that corresponds to the curtailment coefficient. The main controller then sends the pitch reference together with the pitch offset to the pitch regulator to adjust the pitch of the rotor blades accordingly. The curtailment calculations take into account the various power losses within the wind turbine.

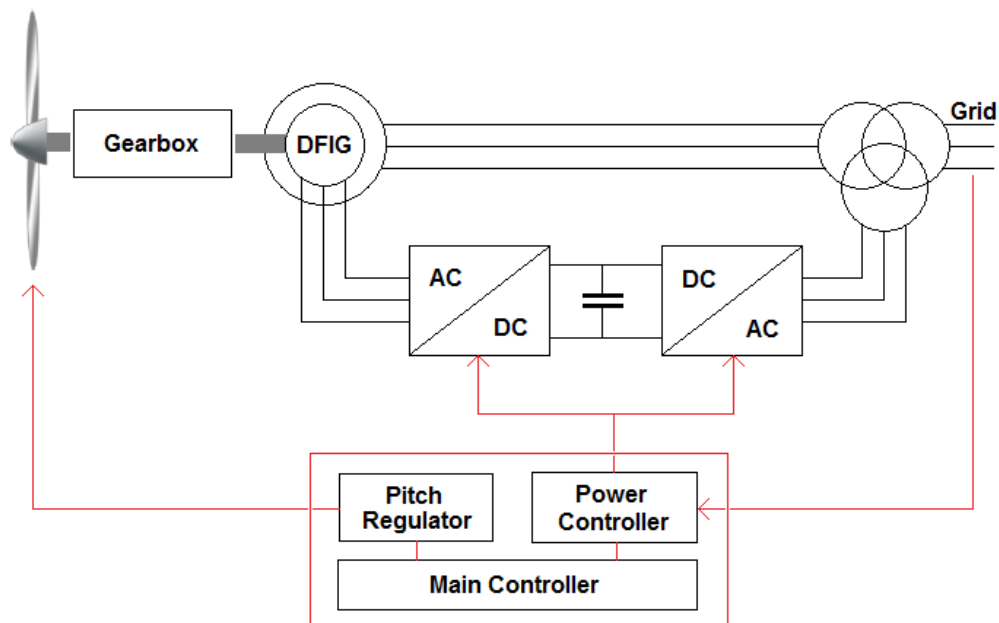

Figure 4.11: DFIG Control scheme for power curtailment [33].

4.4.3 Inertia Control

Many techniques exist in order to emulate inertia in variable speed wind turbines. Many of the techniques entail a combination of inertial control using kinetic energy stored in the rotating mass of the wind turbine along with proportional control. In [34], a frequency support control scheme is proposed that adopts the proportional control strategy similar to that used in conventional generation units. The energy needed is taken from the kinetic energy stored in the rotating masses and only provides support for periods of time consistent with inertial response.

Figure 4.12 illustrates the simplified control scheme for inertial response control following grid frequency disturbances. In this control scheme, a power reference output, P_f^* relating to the deviation in the grid frequency, Δf is provided to the WECS. This power reference output is expressed by the equation:

$$P_f^* = -K_{df} \frac{d\Delta f}{dt} - K_{p_f} \Delta f \quad (\text{eq. 2})$$

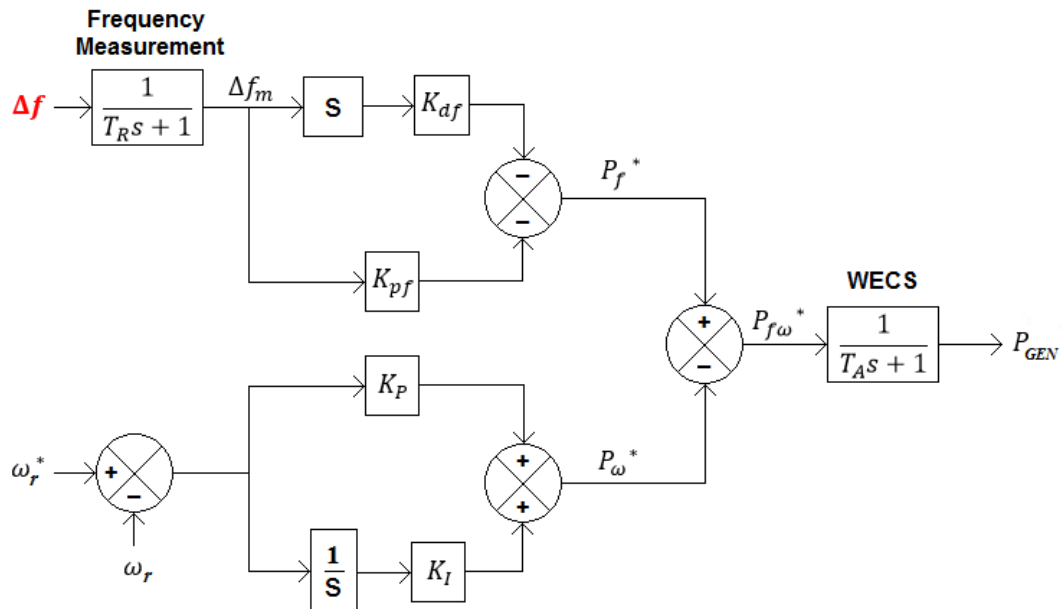

Figure 4.12: Simplified inertial control of a variable speed wind turbine [34].

K_{df} is a weighting constant for the frequency deviation derivative while K_{pf} is the weighting constant for the actual frequency deviation itself. The high pass filter for the frequency deviation blocks permanent frequency deviations from affecting the control strategy. Once the frequency transients have subsided, the power control for the wind turbine recovers the optimal wind turbine speed with the desired speed power reference, P_{ω}^* . The controller design constant K_P is chosen to facilitate fast speed recovery while K_I eliminates steady state errors but at the expense of control lag. This allows the generator to inject the needed amount of active power to dampen frequency deviations. The total active power reference, $P_{f\omega}^*$ provided to the wind turbine is calculated from the difference between P_f^* and P_{ω}^* . An additional improvement to the existing control scheme is proposed by [34] where the wind turbine response is communicated to conventional generators. This is done so that the conventional generators can speedily respond to assist with the load imbalance in the power grid.

4.4.4 Continuous Frequency Regulation

Wind turbines that are required to participate in continuous frequency regulation must reserve a certain amount of generation margin by operating below its maximum generating capacity. This generating margin is used in primary response and governor actions. Larger deloaded margins provide better frequency regulation abilities but the mere practice of deloading contravenes the principle of renewable energy generation and optimal energy conversion. In most instances, wind turbines operate in maximum power production mode and only deload if the system operator requires it for the purposes of frequency regulation as per country specific grid codes. Figure 4.13 illustrates a frequency response control scheme of a DFIG based wind turbine proposed in [35]. The commanding system provides a power command signal, P_{cmd} which is adjusted by the speed-droop, ΔP thus providing the power set point reference value P_{ref} . A reference torque command value, T_{cmd} is then calculated from the reference power and the inertial response loop.

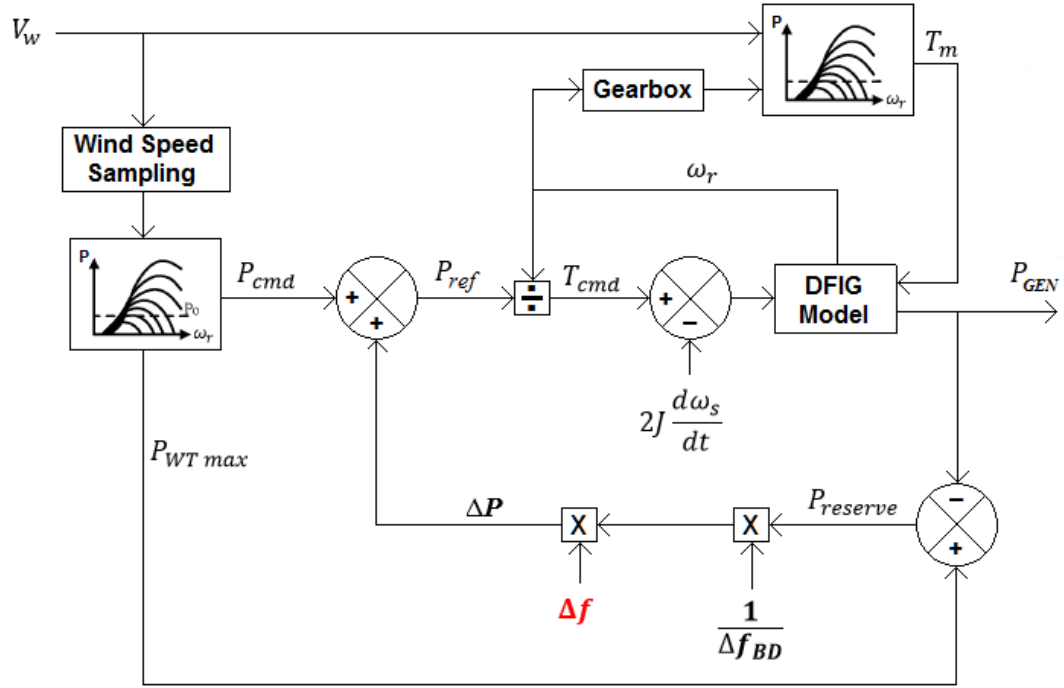

Figure 4.13: Control scheme of continuous frequency control with a DFIG [35].

The generating margin, $P_{reserve}$ is calculated from the difference between the maximum available wind power, $P_{WT max}$ and the power output to the grid from the wind turbine, P_{GEN} . In order to keep the wind procurement as high as possible, [35] proposes an operator command that follows the wind trend by the use of a moving average estimation of wind turbine output with multiples of deviation factor where:

$$P_{cmd} = P_{MA} - K \times P_{dev} \quad (\text{eq. 3})$$

P_{MA} is a moving average of $P_{WT max}$, K is the weighting number and P_{dev} is the deviation of the average value of $P_{WT max}$. This moving average method allows the preservation of a certain amount of power reserve in order to provide the necessary frequency regulation to the grid. High values of the weighting factor ensures higher possibility of wind reserves but the quantity of the wind reserve is uncertain.

Chapter 5

Conclusion

This research report explores the crucial technical specifications within the South African Grid code for wind energy generation and provides comparisons of these specifications with grid codes of countries that have extensive experience and high penetration levels in wind energy generation. This was followed by an investigation into the current state of the art in wind turbines and their ability to comply with common grid code requirements. This led to the pivotal part of the research: An investigation into the various control schemes for the power electronic converters found in variable speed wind turbines.

Grid Codes

Most international grid codes for wind energy generation specify fault ride-through requirements, active/reactive power response requirements, frequency variations limits, active power/frequency regulation as well as reactive power/voltage regulation. It was found that the South African grid code adopted its basic structure from the various international grid codes with minor parameter adjustments. It also categorises wind turbines and provides specifications based on its category. The South African grid code combines HVRT with LVRT requirements. It was found that the country with the most stringent LVRT specifications for symmetrical faults is New Zealand and Australia for asymmetrical faults.

The South African grid code specifies a full reactive current in the event of the voltage at the PCC dropping below 0.5 p.u. This is far less onerous when compared to the Australian code where full reactive current is required at a PCC voltage of 0.75 p.u. The power factor specifications in the South African grid code are that of the UK, Ireland, Denmark and the USA.

Wind Turbine Technologies

The research revealed that Type 1 and Type 2 turbines exhibit poor fault ride-through capabilities due to the direct connection of their stator to the grid. Research also revealed that the variable speed Type 3 and Type 4 wind turbines are the most popular in the current WECS market. The DFIG offer many advantages but suffer from grid faults in the form of voltage sags due to magnetic coupling of the rotor and stator windings. The activation of crowbars results in total loss of control of the RSC and causes the DFIG to absorb more reactive power from the grid thus exacerbating the fault. A DC link chopper proved to be effective in a DFIG as it enables the supply of reactive power during and after a fault. Grid faults have minimal effects on Type 4 turbines due to a full scale converter between the grid and the generator thus making them more fault ride-through capable in comparison to Type 3 turbines.

Grid Compliance Technologies

Among the many fault ride-through schemes investigated, five of them were presented. The method of increasing of rotor speed to manage the power imbalance resulting from a grid fault was found to be the most popular control scheme. The DC link chopper in Type 3 generators ensures LVRT compliance by enabling the generation of reactive power during grid faults and ensures the connection of the generator to the grid. The hybrid current controller proved to enhance the fault ride-through capability of a DFIG based wind turbine by limiting the rotor currents below safety limits thus providing overcurrent protection.

In full scale converter based wind turbines, the stability of the DC link voltage is one of the main concerns. A DC link voltage control scheme was proposed where a power compensation signal is forwarded to the MSC from the GSC control which enabled faster DC link voltage regulation. In this scheme, the power balance can be maintained between the grid and generator during fault conditions.

The use of FACTS with wind farms help to resolve many of the major operating problems such as voltage regulation, power flow control, transient stability and power oscillation damping. A STATCOM provides a desired amount of reactive power or voltage support at the PCC to successfully ride-through various grid disturbances. An INC is used to coordinate the reactive power output between the wind farm and a STATCOM.

Renewable energy sources have attracted significant interest from power producers around the world in recent years. This research into grid codes and the technologies associated with wind power generators is therefore crucial in the field of renewable energy. This research will prove highly valuable to independent power producers and state operators as it will provide them with a platform to enable the integration of renewable power sources to existing power grids. Wind turbine manufactures can also benefit from this research as it will provide them with a holistic and international view into grid codes and the extent to which they vary.

References

- [1] Global Wind Energy Council, "Global Wind Report Annual Market Update," GWEC, Brussels, 2013.
- [2] J. G. Wright, P. M. Tuson and J. M. Van Coller, "Studies for Wind Energy Grid Code Compliance in South Africa," in *Power Engineering Society Conference and Exposition in Africa*, Johannesburg, 2012.
- [3] Government Gazette vol. 478 no. 340, *No. 40 of 2004: National Energy Regulator Act, 2004*, Cape Town: RSA, 2004.
- [4] Government Gazette vol. 493 no. 660, *No. 4 of 2006: Electricity Regulation Act, 2006*, Cape Town: RSA, 2006.
- [5] Government Notice, *Electricity Pricing Policy (EPP) of the South African Electricity Supply Industry*, Department of Minerals and Energy, 2008.
- [6] Government Gazette, *No. 28 of 2007: Electricity Regulation Amendment Act, 2007*, Cape Town: RSA, 2008.
- [7] M. Mohseni and S. M. Islam, "Review of international grid codes for wind power integration: Diversity, technology and a case for global standard," *Renewable and Sustainable Energy Reviews*, vol. 16, pp. 3876-3890, 2012.
- [8] M. Altin, O. Goksu, R. Teodorescu, P. Rodriguez, B. B. Jensen and L. Helle, "Overview of Recent Grid Codes for Wind Power Integration," *International Conference on Optimization of Electrical and Electronic Equipment*, vol. 12, pp. 1152-1160, 2010.
- [9] The RSA Grid Code Secretariat, "Grid Connection Code for Renewable Power Plants (RPPs) Connected to the Electricity Transmission System (TS) or the Distribution System (DS) in South Africa," NERSA, Germiston, 2012.
- [10] EirGrid, "EirGrid Grid Code v5," EirGrid, 2013.
- [11] E.ON Netz GmbH, "Grid Code High and Extra High Voltage," Bayreuth, 2006.

- [12] Energinet.dk, "Technical regulation 3.2.5 for wind power plants with a power output greater than 11 kW," 2010.
- [13] H. Li and Z. Chen, "Overview of different wind generator systems and their comparisons," *IET Renewable Power Generation*, vol. 2, no. 2, pp. 123-138, 2008.
- [14] Y. Amirat, M. E. Benbouzid, B. Bensaker, R. Wamkeue and H. Mangel, "The State of the Art of Generators for Wind Energy Conversion Systems," in *International Conference for Electrical Machines*, Chania, 2006.
- [15] M. Cheng and Y. Zhu, "The state of the art of wind energy conversion systems and technologies: A review," *Energy Conversion and Management*, vol. 88, pp. 332-347, 2014.
- [16] M. A. Abdullah, A. H. Yatim, C. W. Tan and R. Saidur, "A review of maximum power point tracking algorithms for wind energy systems," *Renewable and Sustainable Energy Reviews*, vol. 16, pp. 3220-3227, 2012.
- [17] L. Xu and P. Cartwright, "Direct Active and Reactive Power Control of DFIG for Wind Energy Generation," *IEEE Transactions on Energy Conversion*, vol. 21, no. 3, pp. 750-758, 2006.
- [18] A. O. Ibrahim, T. H. Nguyen and D.-C. Lee, "A Fault Ride-Through Technique of DFIG Wind Turbine Systems Using Dynamic Voltage Restorers," *IEEE Transactions on Energy Conversion*, vol. 26, no. 3, pp. 871-882, 2011.
- [19] R. S. Semken, M. Polikarpova, P. Roytta, J. Alexandrova, J. Pyrhonen, J. Nerg, A. Mikkola and J. Backman, "Direct-drive permanent magnet generators for high-power wind turbines: benefits and limiting factors," *IET Renewable Power Generation*, vol. 6, no. 1, pp. 1-8, 2012.
- [20] M. Ezzat, M. Benbouzid, S. M. Mueeen and L. Harnefors, "Low-Voltage Ride-Through Techniques for DFIG-Based Wind Turbines: State-of-the-Art Review and Future Trends," in *Industrial Electronics Society - IECON*, Vienna, 2013.
- [21] L. Yang, Z. Xu, J. Ostergaard, Z. Y. Dong and K. P. Wong, "Advanced Control Strategy of DFIG Wind Turbines for Power System Fault Ride Through," *IEEE Transactions on Power Systems*, vol. 27, no. 2, pp. 713-722, 2012.
- [22] K. E. Okedu, S. M. Mueeen, R. Takahashi and J. Tamura, "Wind Farm Fault Ride Through using DFIG with New Protection Scheme," *IEEE Transactions on Sustainable Energy*, vol. 3, no. 2, pp. 242-254, 2012.

- [23] F. Sulla, "Fault Behavior of Wind Turbines," Lund University: Department of Measurement Technology and Industrial Electrical Engineering, Lund, 2012.
- [24] C. Gavriluta and S. Spatura, "DFIG Fault Ride Through Control," Aalborg University: Department of Energy Technology, 2011.
- [25] F. Sulla, J. Svensson and O. Samuelsson, "Short-circuit analysis of a doubly fed induction generator wind turbine with direct current chopper protection," *Wind Energy*, vol. 16, no. 1, pp. 37-49, 2013.
- [26] M. Mohseni, S. Islam and M. A. Masoum, "Fault ride-through capability enhancement of doubly-fed induction wind generators," *IET Renewable Power Generation*, vol. 5, no. 5, pp. 368-376, 2011.
- [27] H. Shin, H.-S. Jung and S.-K. Sul, "Low Voltage Ride Through (LVRT) Control Strategy of Grid-connected Variable Speed Wind Turbine Generator System," in *8th International Conference on Power Electronics - ECCE Asia*, Seoul, 2011.
- [28] W. Qiao, R. G. Harley and G. K. Venayagamoorthy, "Effects of FACTS Devices on a Power System which includes a Large Wind Farm," in *IEEE Power Systems Conference and Exposition*, Atlanta, 2006.
- [29] W. Qiao, R. G. Harley and G. K. Venayagamoorthy, "Coordinated Reactive Power Control of a Large Wind Farm and a STATCOM Using Heuristic Dynamic Programming," *IEEE Transactions on Energy Conversion*, vol. 24, no. 2, pp. 493-503, 2009.
- [30] W. Qiao and R. G. Harley, "Indirect Adaptive External Neuro-Control for a Series Capacitive Reactance Compensator Based on a Voltage Source PWM Converter in Damping Power Oscillations," *IEEE Transactions on Industrial Electronics*, vol. 54, no. 1, pp. 77-85, 2007.
- [31] J. Aho, A. Buckspan, J. Laks, P. Flemming, Y. Jeong, F. Dunne, M. Churchfield, L. Pao and K. Johnson, "A Tutorial of Wind Turbine Control for Supporting Grid Frequency through Active Power Control," in *2012 American Control Conference*, Montréal, 2012.
- [32] R. J. Nelson, "Frequency-Responsive Wind Turbine Output Control". United States of America Patent 0001318 A1, 6 January 2011.
- [33] A. Nyborg and S. Dalsgaard, "Power Curtailment of Wind Turbines". United States of America Patent 0286835 A1, 11 November 2010.
- [34] J. M. Mauricio, A. Marano, A. Gomez-Exposito and J. L. M. Ramos, "Frequency Regulation Contribution Through Variable-Speed Wind Energy

Conversion Systems," *IEEE Transactions on Power Systems*, vol. 24, no. 1, pp. 173-180, 2009.

- [35] L.-R. Chang-Chien, W.-T. Lin and Y.-C. Yin, "Enhancing Frequency Response Control by DFIGs in the High Wind Penetrated Power Systems," *IEEE Transactions on Power Systems*, vol. 26, no. 2, pp. 710-718, 2011.
- [36] G. Pannell, B. Zahawi, D. J. Atkinson and P. Missailidis, "Evaluation of the Performance of a DC-Link Brake Chopper as a Low-Voltage Fault-Ride-Through Device," *IEEE Transactions on Energy Conversion*, vol. 28, no. 3, pp. 535-542, 2013.