

Aero Engine Compressor Cooling by Water Injection - Part 2: Performance and Emission Reductions

David Alejandro Block Novelo and Uyioghosa Igie

School of Aerospace Transport and Manufacturing, Cranfield University, Cranfield, UK

Abstract

Take-off and climb up to 3,000 ft. are the flight segments in which the aero-engine experiences the highest operating temperatures, which are known to be accompanied by a high production rate of Nitrogen Oxides (NO_x). This contaminant has negative health implications on the human population, vegetation and wildlife that is in frequent proximity or exposure. Water injection into the compressor offers the possibility of reducing NO_x. Nevertheless, limited studies have focused on the emissions reduction potentials and the wider questions of the influence of engine type and of wide-ranging ambient conditions.

This study continues from Part 1 and explores the implications of the studied ambient conditions on the overall respective engine systems and their consequent emission reduction. An in-house gas turbine performance simulation software has been implemented to model and simulate the engine performance. For the emissions estimation, correlations were made from the information provided by the Engine Emissions Data Bank to quantify the reductions in Nitrogen Oxides.

The 2 and 3-spool engine models investigated demonstrated significant reductions in compressor discharge and turbine inlet temperatures due to water injection. In this condition, the rotational speeds of the compressors are seen to be reduced to counter the mass flow augmenting effect of water injection and to satisfy the fixed thrust constraint. This along with lower compressor specific work brings about an improvement in the specific fuel consumption (5.3% and 7.8%, respectively) and general performance at low and high ambient temperatures. A higher advantage was seen for the 3-spool engine over the 2-spool as shown. Significant reductions in Nitrogen Oxide emissions of over to 50% are also demonstrated.

Keywords: Nitrogen oxides, compressor cooling, aero engine, performance, water Injection

1- Introduction

On a daily basis, more than 600 flights take-off from London Heathrow airport [1]. This can amount to an average of 30 take-offs per hour (accounting for the 6 hours of closure). The take-off phase in a flight is when the highest net thrust is reached, as well as the peak Turbine Inlet Temperature (TIT). The production of Nitrogen Oxides (NO_x) also peaks in this phase, that is related to high combustor temperatures, as also indicated by the International Civil Aviation Organization (ICAO)[2]. Heathrow airport report on Air Quality Strategy shows that departing aircraft is the main contributor of NO_x emissions around the airport [3], and this is revealed to be greater than that contributed by airport-related vehicle traffic, airport boiler plants and airside vehicles, all combined. In addition to this, the report indicates that 46% of the aircraft NO_x emissions at ground level are attributed to the take-off roll, while ICAO states this value can be as high as 70%[2].

The human population living in the locality of busy airports are predisposed to this pollutant and others, which has been proven to develop into respiratory illnesses as well as damage the local water quality and vegetation [4,5]. Regulatory authorities around the world are making efforts to mitigate emissions through the introduction of emission-based fees that are becoming more stringent. The European Strategic Research Innovation Agenda (SRIA)[6] target is to cut NO_x emissions by 90% in 2050 compared to 2000 levels. ICAO certified engines of today are required to produce up to 15% less NO_x than they did in 2005 [7]. In October 2017, Heathrow airport increased the emission-based charges to £15.96 per kg of NO_x compared to £8.15 implemented from October 2015, that is related to the Landing and Take-Off (LTO) cycle of an aircraft [8]. Some common technologies focused on reducing aircraft emissions, including combustion chamber design and new aircraft-engine configurations can be found in [9–12].

Water injection into the jet engine core flow after the fan has the potential of considerably reducing the combustor inlet temperature (i.e. compressor discharge temperature – CDT) as a result of the compressor air cooling effect that also augments the air density and mass flow. Although there are several studies of compressor water injection into axial flow compressors, only a few studies highlight the performance changes of a complete gas turbine engine system. Sun et al. [13,14] report 3D CFD through-flow method for a single spool turbojet engine with a 3-stage axial flow compressor. The simulations were conducted for different droplet diameters and injection ratios. At 2% injection ratio with 5 μ m droplets, the air mass flow (AMF) increased by 8% and the thrust by 12.5%, while the CDT, TIT, Specific Fuel Consumption (SFC) and NO_x reduced by 40 K, 75 K, 3.5% and 60% respectively. The work outlines the importance of droplet diameter and injection quantity as the two main variables but does not evaluate the impact of engine configuration or ambient conditions presented in this study. Favorskii et al. [15] present an experimental analysis of a single spool engine with two droplet diameters, for constant TIT and constant power output. The investigations show a decrease in the compressor specific work accompanied by a 3.2% increase in mass flow for a 1.5% injection ratio. In addition to this, an 18% increase in power output was obtained, keeping TIT fixed. Utamura et al. [16] obtained 23% increase in power output with 2.3% injection ratio accompanied by a 2.8% increase in thermal efficiency, using an equilibrium analytical model. The results are confirmed with experiments of a single shaft gas turbine.

Sexton et al. [17] noticed reductions in SFC of up to 8.8% when 2.5% injection ratio was implemented. The application here was focused on potentially reducing the size of a naval gas turbine propulsion power plant by the use of water injection. The study also reports a decrease in NO_x by around 25% for a 0.45% injection ratio, at fixed TIT. A summary of the findings of 7 different studies comprising of CFD, experimental and analytical methods are shown and compared to the results of this study in Appendix A.

With the exception of Daggett et al. [18] none of these studies, however, address the performance of multi-shaft engines, or the application of water injection into aero-engines at constant thrust. Although White and Meacock [19] is a study on 3-spool engines, the study was conducted only for the compressor and not the complete engine. This study intends to fill those gaps by outlining the importance of injecting water after the fan as opposed to at atmospheric conditions, pointing out the advantages in performance when operating at constant thrust. Two engine configurations (2 and 3-spool type) representative of modern high by-pass ratio turbofan engines is the focus of this work. Their stand-alone compressor section from the fan inlet to the intermediate compressors (booster or IPC) have been studied in Part 1 [20], considering the influence of varied injection rate, droplet size and ambient conditions on the intermediate compressors exit temperatures. These operating temperatures are used as boundary conditions for the engines in this second part, related to the water injection regime. Further to this, a correction is employed to account for the changes in gas properties (C_p and R) which cannot be applied in the simulating software TURBOMATCH. Details of this are provided in Appendix B. This study's approach has provided the opportunity to study the evaporative process in greater detail and also overcome current limitations in capturing some of these effects using a well established in-house gas turbine performance simulation code: TURBOMATCH.

2- Methodology and Engines under Investigation

The performance of the 2 and 3-spool engine due to compressor water injection has been modelled and simulated using the zero-dimensional code. The design point calculation is achieved with initial user specification of ambient conditions, air mass flow, major component pressure losses and efficiencies, engine constraint (fixed net thrust in this case) etc. The code is embedded with standard compressor and turbine maps that allow for map scaling and combustion temperature rise chart for off-design calculations. Convergence is reached in the component matching after satisfying compatibility of non-dimensional rotational speed, work and flow between the compressors and turbines. The program simulates the design and off-design performance of most gas turbine types using a modified

Newton-Raphson method as the convergence technique. The iterative process involves several trials to ensure that the variables are consistent with the matching constraint. Further details of the methodology are provided in Macmillan [21] and Igie and Minervino[22]. Table 1 indicates the design point specification for both engine models at ISA cruise conditions. It can be observed that the cruise net thrust of the 3-spool engine is 2.6 times that of the 2-spool engine (this is due to the engines application rather than their different architecture). In addition to this, the take-off net thrust for both engines are 310kN and 133kN respectively and forms the reference point for all the simulations. This is essential because the injection of water is considered during take-off, nevertheless, such applications of jet engines are typically optimised for cruise operation and hence the design point is set at cruise condition. The relative error between published values of SFC during take-off and the calculated off-design values of the model are 1.22% and 1.79% for the 2 and 3-spool engines respectively. A depiction of the relative difference in design architecture of both engines is shown in Fig. 1. This diagram also points to the positions of water injection described in Part 1 with the exception of the Position 2 – LD that has not been considered in this part of the study. This is due to similar changes in the IPC exit temperature due to water injection under the same conditions.

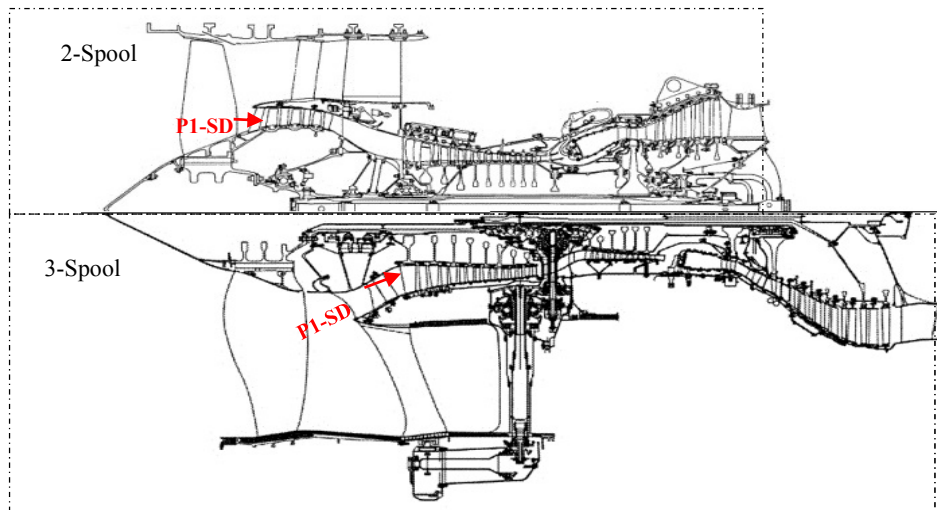

Figure 1 Architecture of the two and three-spool engines, Image adapted from [23]

Table 1. Design point specification of engine models – Cruise ISA Altitude: 10,886, $Ma=0.85$

Parameter	2- Spool	3- Spool
Net thrust (kN)	26	67
Mass flow rate (kg/s)	172	540
BPR	5.48	10.7
OPR	31.6	50
Fan pressure ratio	1.64	1.65
Fan isentropic efficiency (%)	90	92
Booster/IPC pressure ratio	2.8	5.5
Booster/IPC isentropic efficiency (%)	88	90
HPC pressure ratio	6.86	5.52
HPC isentropic efficiency (%)	88	90
HPT cooling flow (%)	13	18
Cabin Press. Bleed (%)	2	2
Combustion efficiency (%)	99.9	99.9
Combustion chamber pressure loss (%)	5	5
TIT (K)	1439	1710

HPT isentropic efficiency (%)	90	90
IPT isentropic efficiency (%)	N/A	91
LPT isentropic efficiency (%)	93	93
SFC (g/kN*S)	16.98	14

3- Performance of Engines

The performance of the engines due to water injection is presented in this section for $5\mu\text{m}$ droplets and injection ratios of up to 3% for both engines. The ambient temperatures studied here are 278, 288, 298 and 303K with subsequent emphasis on the lowest and highest that represents common winter and summer temperatures. When water is injected into the compressor, this lowers the gas temperature, leading to an increase in its density. This causes a rise in the core Air Mass flow (AMF) shown in Fig. 2 and a reduction in the Compressor Discharge Temperature (CDT) shown in Fig. 3. Fletcher and Walsh [24] recognise this fundamental characteristic of water injection and associate it to the increased air density rather than the added water mass flow. The increases in air mass flow at 2% injection ratio can be around 6% or 8% depending on the engine architecture as shown in Fig. 2. The 3-spool engine shows a better improvement, influenced by a larger drop in the rotational speed of the HPC spool from 104% to 93% of its nominal take-off speed. This is to a lower extent for the 2-spool that is constrained by the fan on the same shaft as shown subsequently. These changes are also reflected on the CDT shown in Fig. 3. In general, these figure shows very little influence of ambient temperatures on these outcomes due to water being injected after the fan, as explained on Ref. [20]. The higher reductions in CDT seen on the 3-spool engine are due to the water being injected at the entrance of the IPC which is a physically longer compressor with higher temperature and pressure ratio than that seen for the booster of the 2-spool engine. This allows for greater temperature reductions as the intercooling effect is larger. In the case of the 2-spool engine, for almost all the cases, there was unevaporated water at the exit of the booster that finished evaporating in the duct between the booster compressor and the HPC as shown in paper 1.

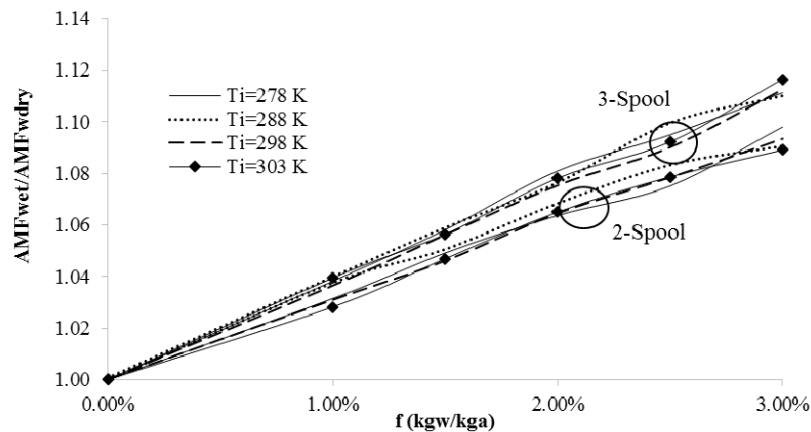

Figure 2 Increase in AMF as a function of water injection ratio for different ambient temperatures and 30% RH

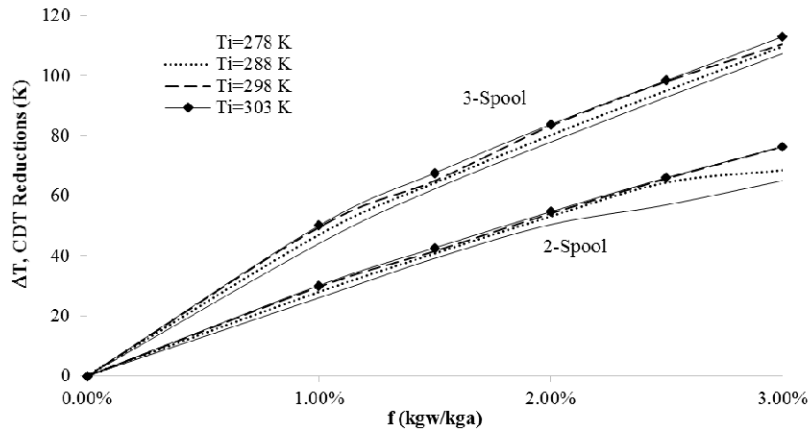

Figure 3 Drop in CDT as a function of water injection ratio for different ambient temperatures and 30% RH

The influence of droplet size on the increase in AMF is shown in Fig. 4 for the case of the 3-spool engine. Smaller droplets, due to their larger surface area-to-volume ratio are more effective at cooling the air, and thus, for the same water quantity, they have a higher impact on increasing the density and in consequence, the AMF. The 2 and 5 μm droplets have the same effect, dominated by the evaporation in the duct before the compressor, while the 10 μm droplets tend to last for longer and to complete their evaporation in the later stages of the compressor. The 2-spool engine showed smaller AMF increases, due to smaller temperature drops, as seen in Fig. 2, but not presented again for the presentation clarity of Fig. 4. The droplet diameter, is a fundamental control variable, just as important as the water quantity, as this value determines the performance changes of the entire engine.

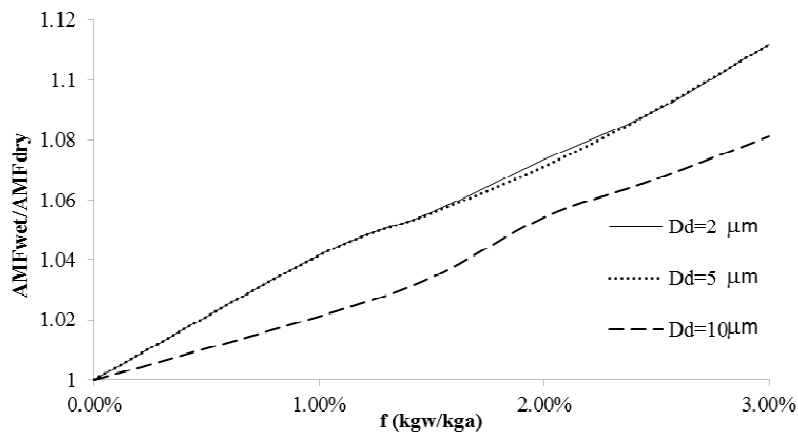

Figure 4 Increase in AMF as a function of water injection ratio for different droplet sizes and 30% RH

Figure 5 shows that the actual fuel utilised reduces further to achieve the same required thrust when the injection ratio increases. At 2% injection rate, this is possible due to the increased mass flow that is accompanied by an approximately constant Overall Pressure Ratio (OPR) as shown in Table 2. The increased mass flow is also counterbalanced by a reduction in the HPC rotational speed shown in the table, in order to achieve the required fixed thrust. Figure 5 also shows the impact of ambient temperature on the fuel utilised, indicating generally better reductions at a lower temperature than at the higher temperature. This is mainly due to the improvement in the air density in lower temperature that begins from the fan inlet. The corresponding rematching of components as a result of this, which leads to subsequent changes of compressor air temperature is not entirely captured in Part 1 paper[20] and hence, has a slight effect on the specification of the input boundary conditions in this part of the study. The figure also compares the 2 and 3-spool engines, indicating that the 3-spool engine fuel reductions are more significant due the temperature ratios accounted for in the compressor model in Paper 1 and consistent with the specification in Table 1. This is related to further evaporation and intercooling in the 3-spool engine, leading

to higher specific work reductions as shown in Fig. 6. For brevity, the impact of relative humidity is not included given discussions in Part 1[20]. When water was implemented at 30% relative humidity, the reductions were less than 1% point difference better, as compared to water being implemented at 80% relative humidity, on the 2-spool engine. A lower relative humidity (drier day) allows for faster evaporation due to the lower water vapour mass concentration in the air. This finding on an engine system level is consistent with the relatively small changes discussed in Part 1. Figure 5 also shows that for the 2-spool engine, at 2% injection ratio and 303K, there is an upward deviation of the trend due to saturation conditions reached before the air gets to the booster.

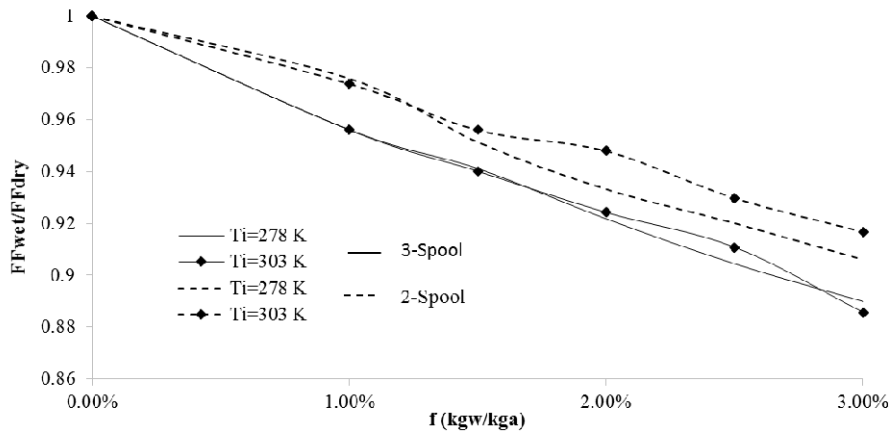

Figure 5 Fuel flow reductions versus injection ratio for different ambient temperatures and 30% RH

Table 2 Change in pressure ratios and rotational speeds at 2% injection rate and 303K

Parameters	2-Spool		3-Spool	
	Dry	Wet	Dry	Wet
OPR	30.9	31.3	42.4	42.9
Fan PR	1.62	1.63	1.499	1.5
Fan rotational speed	107%	102%	101%	93%
Booster/IPC PR	2.29	2.3	5.16	5.2
IPC rotational speed*	-	-	103%	96%
HPC PR	8.32	8.38	5.48	5.48
HPC rotational speed	109%	103%	107%	99%

* IPC and Fan rotational speeds are the same in the 2-spool engine

Further to the comments on the reductions in the specific work with injection ratio, a reduced specific compressor work or power translates to an improved available net power (Fig.6). As the thrust is kept constant in this study, a higher drop in the specific compressor work is expected when compared to a case of augmented thrust, and this is accompanied by a reduction in fuel flow as shown in Fig 5. The consequent TIT drop is shown in Fig. 7, indicating that an increase in injection ratio causes an improvement in the turbine operating temperature for the same thrust setting. The reductions seen are an effect of the improved air mass to volume ratio that brings about the possibility to utilise less fuel. At 303K and 2% injection ratio, the 2-spool engine achieves a temperature drop of 160 K (i.e. is close to 10% reduction), while the 3-spool engine attains a temperature drop of 240K (around 13% drop) as shown in Fig. 7. This also shows that the changes are almost independent of the ambient temperatures. Daggett et al. [22] predicted close to 14% reduction with 2.2% injection ratio for a 2-spool aero-engine.

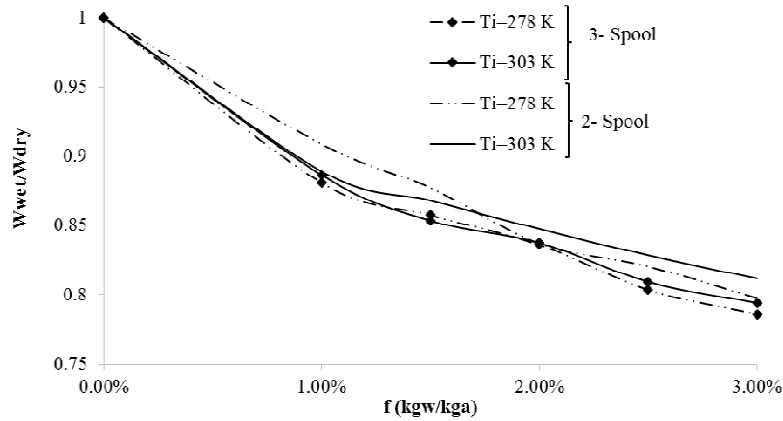

Figure 6 Compressor specific work versus injection ratio at different ambient temperatures and 30% RH

Generally, injecting water into the compressor has a similar effect on the engine performance as operations at low ambient temperatures (without water injection). For example, at 298K and 60% RH, injecting water at a ratio of 2%, would result in a TIT drop of 240K (13% decrease) for a 3-spool engine. This TIT drop can be achieved for the same thrust if the ambient temperature is dropped by 40K (i.e. 258K). According to Cumpsty [25], the TIT has been rising by an average of 8 K per year for a given manufacturer, over the past 20 years in the search for more fuel-efficient engines. This value, however, is limited by the materials of the hot section or the cooling technologies which are associated with lengthy and costly development times. The TIT reductions seen by compressor water injection offer interesting possibilities for existing engines in terms of creep life extension and possibly engine sizing for future engine and airframe. The former is particularly important as 36% of the life of a gas turbine is consumed during the take-off phase which only represents 1.6% of the on-time of the engine [22]. Cooling the flow during this critical phase will have considerable implications on life extension and maintenance cost savings.

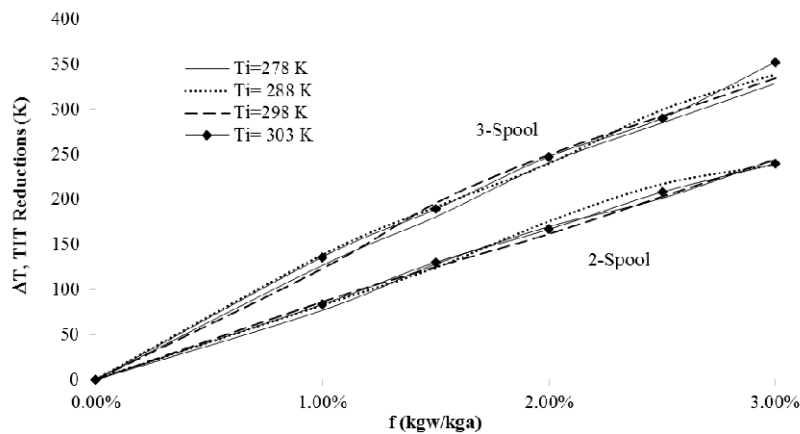

Figure 7 TIT drop versus injection ratio at different ambient temperatures and 30% RH.

4- Emission Reductions

It is well known that combustion NO_x emissions are dependent on flame temperature [4] OPR [26] and humidity [27]. Marchionna [27] proposed correlations to correct NO_x measurements to account for the presence of humidity. These correlations were later adopted by ICAO [7] and NEPAIR [26] as the industry standard for corrections. The need to account for pressure corrections is also well known and estimated to be in proportion to the OPR elevated to an exponent, n , with a value ranging between 0.4 - 0.8 depending on the combustion chamber design [4]. The methodology implemented in this study is that proposed by NEPAIR [26] and ICAO [28].

The ICAO Engine Emissions Data Bank [2] consists of $EINO_x$ values related to the corresponding LTO power settings (7% for idle, 30% for approach, 85% for the climb and 100% for take-off). As such, the same power settings were simulated in TURBOMATCH, thereby using the obtained corresponding CDT or combustor inlet temperature to match the $EINO_x$. The CDT can be related to $EINO_x$ for water injection, and further to this, changes in pressure ratio and water vapour content were accounted for by applying Equ 1, leading to the final relationship shown in Fig.8 for the corrected $EINO_x$. This figure shows a close estimation in comparison to the ICAO data.

$$EINO_x_{corrected} = \frac{EINO_x}{\left(\frac{P_{ref}}{P}\right)^{0.5} * e^{(19*(w-w_{ref}))}} \quad (1)$$

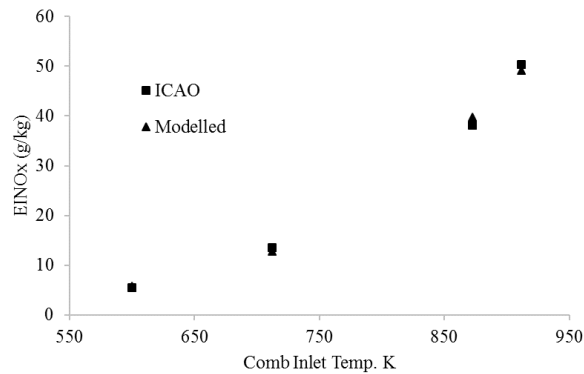

Figure 8 $EINO_x$ versus Combustor Inlet Temperature - comparison between ICAO EEDB and the calculated value

Figures 9 and 10 show the reductions in NO_x with injection ratio increase, focusing on the influence of ambient temperature and droplet size. The influence of ambient temperature is clearly shown to be negligible for these temperatures that bring about promising potentials for low temperatures than initially thought. The reduction of NO_x is 49-54% (depending on the droplet diameter) at 2% injection ratio for the 2-spool engine. This compares well with Daggett [29] for the same engine design type that reports 47% reduction using a similar methodology at 2.2% injection ratio. Consistent with the other findings, the 3-spool engine promises better reductions as shown. The influence of droplet size for the same injection ratio shows to be more beneficial with smaller droplets as a result of the better mass flow augmentation obtained (as shown in Fig 4) from the more effective cooling explained in Part 1.

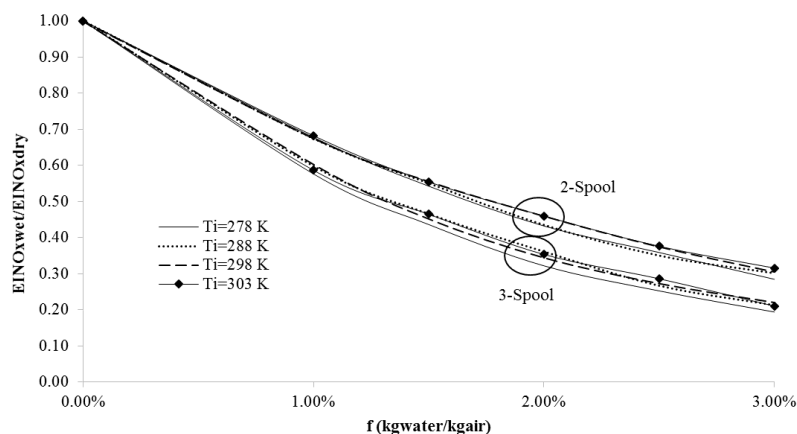

Figure 9 Effect of ambient temperature on Take-Off $EINO_x$ for different injection ratios

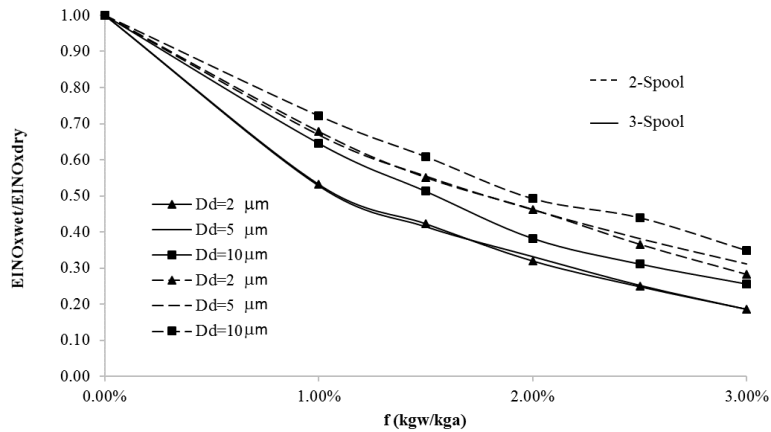

Figure 10 Effect of droplet size on Take-Off EINO_x for different injection ratios

These NO_x savings can be considerable for both, an airport and an airline. A 2-spool engine such as the CFM56-5B quoted earlier, will produce 5.45 kg of NO_x, per take-off and climb to 3000 ft. [2]. Which means an aircraft with this engine will pay Heathrow airport an environmental fee around £168 per cycle for a 2-engine aircraft based on charges published in [8]. The same case for a 3-spool engine would mean 14.99 kg of NO_x per engine, which would represent a charge of £462 per cycle (considering the 2017 charges), also for a 2-engine aircraft. Such a system applied to the core flow and behind the fan could cut these charges in 50-60%. Equally, an airport like Heathrow, which at the time of writing exceeds the annual average levels of 40 μg/m³ of NO_x imposed by the European Union, could greatly benefit from this. With the same simplification, this can amount almost 3,000 kg less NO_x (if every engine taking-off from Heathrow airport was powered by a CFM-56 type 2-spool engine), improving the air quality of the surrounding neighbourhoods. In terms of regulations, if the reductions seen in Fig.9 are applied to two typical engine configurations analysed, for the 2 and 3-spool engines, LTO NO_x emissions can be cut by 42 and 51% respectively. This can be plotted against the ICAO regulations, set by the CAEP[7] meetings, as shown in Fig. 11. The figure shows how the Trent1000G engine (certified in 2011), has to comply with the CAEP/8 (2014) regulations. Implementing water injection would make this engine comply with the long-term goal 2026 of ICAO. In order to reduce NO_x emissions in high-pressure ratio (and thus, high temperature) engines, manufacturers have to invest a lot of time in redesigning the combustion chamber to create staged, lean or quenched combustion. The NO_x reductions by water injection, however, can be achieved without a combustion chamber re-design, and at a lower development and manufacturing cost. The CFM56-5B engine (Certified in 1995) complies with CAEP/6 but not with CAEP/8. Water Injection would not only make this engine comply with the latest regulation but would also achieve the mid-term ICAO goals.

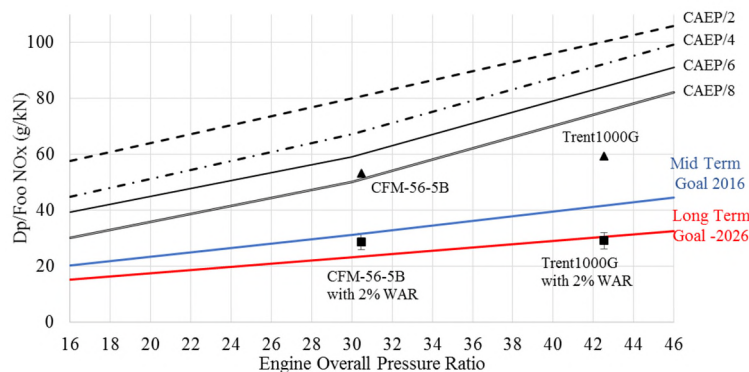

Figure 11 2 and 3-spool engine NO_x reductions plotted against CAEP regulations and goal.

5- Conclusions

This study has explored aero engine compressor cooling by water injection indicating the potential benefits when the droplet atomisation is implemented behind the fan. The clear benefits for constant thrust operations are as follows:

- Reduction in the fuel flow, hence SFC as much as 5.3% and 7.8% for the 2 and 3-spool engines at 2% injection ratio with 5 μ m
- Decrease in NO_x emissions by 63% and 54% for both engines respectively at mentioned injection ratio and droplet size
- Drop in TIT by 247 K and 167 K respectively
- Further improved benefits in performance and emissions when the injection ratio is increased to 3%
- Better performance when using relatively smaller droplets with the higher surface area-to-volume ratio.

Nevertheless, the difference between the benefits in SFC and NO_x reductions alongside a drop in TIT for 5 and 10 μ m makes the latter worth considering due to practical reasons associated with generating fine droplets. For the 3-spool engine using 10 μ m at 2% injection ratio, these reductions are 4.5%, 56%, and 198K respectively. The 2-spool engine shows comparable similarity with regards to these two droplet sizes. Further details are provided in Appendix C.

Both engines significantly benefit from water injection, nevertheless, the 3-spool engine has an advantage over the 2-spool engine that has been attributed to the higher operating temperature and mass flow. The influence of ambient temperature is generally small when 5 μ m droplet is considered as shown.

These findings indicate the promise of this technology that can be fitted to existing engines with relatively small adaptations in the current infrastructure when compared to other concepts focused on mitigating emissions. This can bring about a tangible and realistic reduction in the environmental footprint of airports if deployed by airlines in good numbers, apart from the direct benefit it offers to the airline in terms of fuel cost reduction and creep life extension of turbine blades. The actual reductions in fuel utilised for the same net thrust bring about a direct reduction in CO₂ emissions, expected to be in the same order of magnitude of fuel flow reductions.

Acknowledgments

This work was supported by the Mexican National Council for Science and Technology (Conacyt), and by the Centre for Propulsion of Cranfield University.

Nomenclature

CO ₂	Carbon Dioxide	m	air mass flow
CDT	Compressor Discharge Temperature	NO	Nitrogen Oxide
CFD	Computational Fluid Dynamics	NO _x	Nitrogen Oxides
C _p	Specific Heat (J/kgK)	PR	Pressure Ratio
EEDB	Engine Emissions Data Bank	r	Pressure Ratio
EINO _x	Emission Index of NO _x	SD	Short Duct
γ	specific heat ratio	SFC	Specific Fuel Consumption
η	efficiency	SRIA	Strategic Research and Innovation Agenda
HBPR	High By-Pass Ratio	TIT	Turbine Inlet Temperature
ICAO	International Civil Aviation Organization	W	specific work
IPC	Intermediate Pressure Compressor	LPC	Low-Pressure Compressor
LD	Long Duct	LTO	Landing and Take-off Cycle

Appendix A

Seven publications are compared to the findings of this article for different engine configurations and different techniques for water injection simulation. The references are listed chronologically from Sexton et al. (1998) to the release of this study

Table A.1 Comparison between this study and open-literature

	Water to Air ratio (f)	Droplet Dia (μm)	Technique	CDT	TIT	Power/Thrust	Efficiency	NOx	Mair	Engine Config
Sexton et al.	2.5%	10.0	Analytical	-15.0%	-	34.0%	8.8%	-25% (f=0.45%)	5.0%	1-Spool
Utamura et al.	2.3%	-	Experimental/Analytical	5% (f=0.5%)	-	23.0%	2.8%	-	-	1-Spool
Dagget. Et al.	2.2%	-	Analytical	-14.0%	-14.0%	Constant	3.5%	-47.0%	-	2-spool
Sanaye et al.	2.0%	20.0	Analytical/CFD	-19.0%	unchanged	18.0%			5.0%	1-Spool
Sun et al.	2.0%	5.0	3D Throughflow	-7.7%	-7.7%	11.4%	3.5%	-60.0%	8.0%	1-Spool
Favroskii et al.	1.5%	-	Experimental/Analytical	-	-	const/+18%	-	-	3.2%	-
Luo et al.	2.0%	5.0	CFD	-17.0%	-	-	-	-	4.0%	1-Spool
This study 2-s	2.0%	5.0	Analytical	-13.0%	-10.0%	Const. Thrust	5.2%	-55.0%	6.5%	2-spool
This study 3-s	2.0%	5.0	Analytical	-14.0%	-13.0%	Const. Thrust	7.7%	-65.0%	7.8%	3-spool

Appendix B.

As an alternative to re-calculating the gas properties to account for humidity, correlations were derived similarly to those found in Ref. [32] for each engine model to correct the results for the “dry” engine, and account for the presence of humidity. This was done because although the evaporative model was coupled to the performance software to modify the compressor discharge temperature, the latter doesn’t have a module to specify the absolute humidity at the exit of the compressor. To derive the correlations, the engine model was run under the same conditions but for varying inlet relative humidity. The performance was then correlated to the water-to-air content of the air. These correlations (Equations B.1- B.8) were then applied to the “dry” engine output parameters to account for the varying gas properties leading to the “Corrected with correlations”. These two curves correspond to “Corrected with correlations” and “Modified Gas Properties” on Fig.B1. The values corrected by means of the Agard correlations in Ref. [32] are also shown for comparison. On Fig.B1, only the mass flow was plotted by means of Eq.(B.a). Note that the changes are very small, and the errors even at high humidity or water vapour are below 0.25% for the Agard correlation.

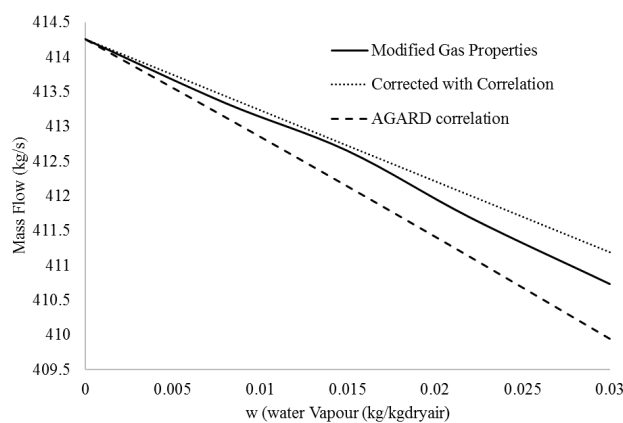

Figure B1 Mass Flow Corrections for Humidity

Curves like Fig. B1 were developed for each performance parameter (and engine); correlations were made to adjust the dry values for those with an increased level of water vapour.

2- Spool engine at Constant Thrust:

$$M_a' = M_{aDRY} * (1 - 0.247 * w) \quad (B.1)$$

$$OPR' = OPR_{DRY} * (1 - 0.390 * w) \quad (B.2)$$

$$TIT' = TIT_{DRY} * (1 - 0.240 * w) \quad (B.3)$$

$$SFC' = SFC_{DRY} * (1 + 0.568 * w) \quad (B.4)$$

3- Spool engine at Constant Thrust

$$M_a' = M_{aDRY} * (0.311 * w^2 - 0.294 * w + 1) \quad (B.5)$$

$$OPR' = OPR_{DRY} * (0.856 * w^2 - 0.535 * w + 1) \quad (B.6)$$

$$TIT' = TIT_{DRY} * (0.780 * w^2 - 0.461 * w + 1) \quad (B.7)$$

$$SFC' = SFC_{DRY} * (-0.237 * w^2 + 0.555 * w + 1) \quad (B.8)$$

Appendix C

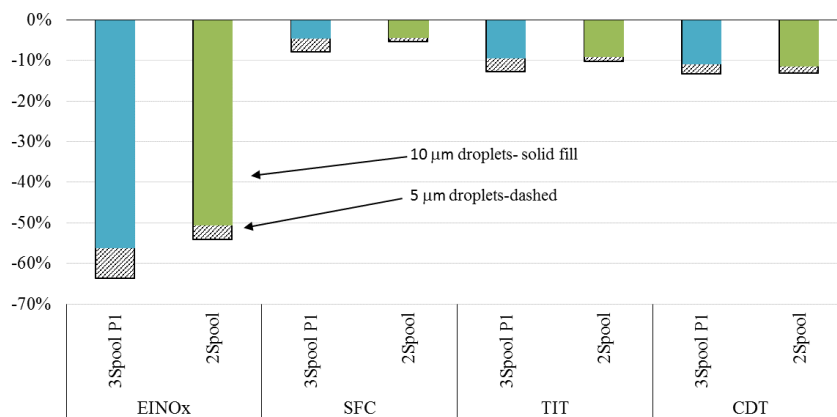

Figure C1 EINOx, SFC, TIT, CDT reductions for 2% injection ratio at two droplet diameters (298K, 30% RH)

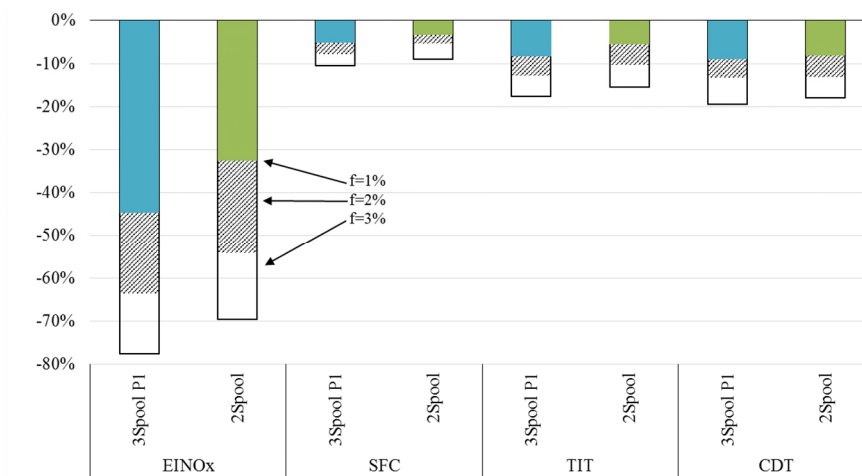

Figure C2 EINOx, SFC, TIT, CDT reductions for 5 μm droplets and 1, 2, 3% injection ratio (298K, 30% RH)

References

[1] Heathrow Airport Limited, 2017, "Heathrow Airport Facts and Figures" [Online]. Available: <http://www.heathrow.com/company/company-news-and-information/company-information/facts-and-figures>. [Accessed: 07-Aug-2017].

- [2] ICAO, 2013, ICAO Engine Exhaust Emissions Data Bank.
- [3] Heathrow Airport Limited, 2011, Heathrow Air Quality Strategy 2011-2020.
- [4] Lefebvre, A. H., and Dilip, R. B., 2010, Gas Turbine Combustion Alternative Fuels and Emissions, CRC Press, New York.
- [5] EEA (European Environment Agency), 2016, "Nitrogen Oxides (NOx) Emissions" [Online]. Available: <http://www.eea.europa.eu/data-and-maps/indicators/eea-32-nitrogen-oxides-nox-emissions-1/assessment.2010-08-19.0140149032-3>. [Accessed: 05-Jul-2016].
- [6] Advisory Council for Aviation Research and Innovation in Europe, A., 2012, Strategic Research & Innovation Agenda- Volume 1.
- [7] ICAO- International Civil Aviation Organization, 2013, 2013 Environmental Report, Aviation and Climate Change.
- [8] Heathrow Airport Limited, 2017, Heathrow Airport Limited Conditions of Use including Airport Charges from 1 January 2017.
- [9] Liu, Y., Sun, X., Vishal, S., Nalianda, D., Li, Y.-G., and Wang, L., 2017, "Review of Modern Low Emissions Combustion Technologies for Aero Gas Turbine Engines," Prog. Aerosp. Sci., **94**(2017), pp. 12–15.
- [10] Grönstedt, T., Rolt, A., Tantot, N., Xisto, C., Donnerhack, S., Schmitz, O., Seitz, A., and Lundbladh, A., 2016, "Ultra Low Emission Technology Innovations for Mid-Century Aircraft Turbine Engines," ASME Turbo Expo: Turbomachinery Technical Conference and Exposition, pp. 1–13.
- [11] Kyprianidis, K. G., and Dahlquist, E., 2017, "On The Trade-off Between Aviation NOx and Energy Efficiency," Appl. Energy, **185**(x), pp. 1506–1516.
- [12] Schäfer, A. W., Evans, A. D., Reynolds, T. G., and Dray, L., 2016, "Costs of Mitigating CO2 Emissions from Passenger Aircraft," Nat. Clim. Chang., **6**(April).
- [13] Sun, L., Zheng, Q., Li, Y., Luo, M., Wang, J., and Bhargava, R. K., 2012, "Numerical Through Flow Simulation of a Gas Turbine Engine With Wet Compression," ASME Turbo Expo, pp. 1–13.
- [14] Sun, L., Sun, T., Wang, Y., and Yang, W., 2016, "Numerical Simulation of Pollutant Emission of A Turbojet Engine with Water Injection," ASME Turbo Expo 2016: Turbomachinery Technical Conference and Exposition GT2016, Seoul, pp. 1–9.
- [15] Favorskii, O. N., Alekseev, V. B., Zalkind, V. I., Zeigarnik, Y. A., Ivanov, P. P., Marinichev, D. V., Nizovskii, V. L., and Nizovskii, L. V., 2014, "Experimentally Studying TV3 117 Gas Turbine Unit Characteristics at Superheated Water Injection into a Compressor," **61**(5), pp. 376–384.
- [16] Utamura, M., Takehara, I., Horii, N., and Kuwahara, T., 1997, "A New Gas Turbine Cycle for Economical Power Boosting," Am. Soc. Mech. Eng., **97-NaN-142**, pp. 1–10.
- [17] Sexton, M. R., Urbach, H. B., and Knauss, D. T., 1998, "Evaporative compressor cooling for NOx Suppression and Enhanced Engine Performance for Naval Gas Turbine Propulsion Plants," Am. Soc. Mech. Eng., **98-GT332**, pp. 1–10.
- [18] Daggett, D. L., 2004, Water Misting and Injection of Commercial Aircraft Engines to Reduce Airport NO x.
- [19] Meacock, a. J., and White, a. J., 2006, "The Effect of Water Injection on Multispool Gas Turbine Behavior," J. Eng. Gas Turbines Power, **128**(1), p. 97.
- [20] Block Novelo, D. A., and Igie, U., 2018, "Aero Engine Compressor Cooling by Water Injection - Part 1: Compressor Model," Appl. Therm. Eng.
- [21] Macmillan, W. L., 1974, "Development of a Modular Type Computer Program for the Calculation of Gas Turbine Off Design Performance- Phd. Thesis," Cranfield Institute of Technology.

- [22] Igie, U., and Minervino, O., 2014, "Impact of Inlet Filter Pressure Loss on Single and Two-Spool Gas Turbine Engines for Different Control Modes," *J. Eng. Gas Turbines Power*, **136**(9), p. 91201.
- [23] Daly, M., 2015, *Jane's Aero-engines*, Janes Information Group.
- [24] Walsh, P. P., and Fletcher, P., 2004, *Gas Turbine Performance*, Blackwell Science, Oxford.
- [25] Cumpsty, N., 1997, *Jet Propulsion a Simple Guide to the Aerodynamic and Thermodynamic Design and Performance of Jet Engines*, Cambridge University Press, Cambridge.
- [26] Norman, P., Lister, D., Lecht, M., Parlk, K., Penanhoat, O., Plaisance, C., and Renger, K., 2003, *Development of the technical basis for a New Emissions Parameter covering the whole Aircraft operation: NEPAIR*.
- [27] Marchionna, N. R., 1973, *Effect of Inlet-Air Humidity on the Formation of Oxides of Nitrogen in a Gas-Turbine Combustor- TMX-68209*, Ohio.
- [28] ICAO-International Civil Aviation Organisation, 2008, *Environmental Protection, Annex 16, Volume II Aircraft Engine Emissions*, Chicago.
- [29] Daggett, D. L., Ortanderl, S., Eames, D., Snyder, C., and Berton, J., 2004, "Water Injection : Disruptive Technology to Reduce Airplane Emissions and Maintenance Costs," *SAE Tech. Pap. Ser.*, **1**(3108).
- [30] Sanaye, S., and Tahani, M., 2010, "Analysis of gas turbine operating parameters with inlet fogging and wet compression processes," *Appl. Therm. Eng.*, **30**(2-3), pp. 234-244.
- [31] Luo, M., Zheng, Q., Sun, L., Deng, Q., and Yang, J., 2014, "The Effect of Wet Compression on a Multistage Subsonic Compressor," *J. Turbomach.*, **136**(March 2014), pp. 1-8.
- [32] AGARD, 1995, *Recommended Practices for the Assessment of the Effects of Atmospheric Water Ingestion on the Performance and Operability of Gas Turbine Engines*, Neuilly-Sur-Seine.