

CRANFIELD UNIVERSITY

MARK HELLIKER

DEGRADATION OF FABRICS USED IN MILITARY FRAGMENT
PROTECTIVE CLOTHING DUE TO SELECTED LAUNDERING
REGIMES

DEFENCE ACADEMY

CENTRE FOR DEFENCE ENGINEERING

PhD THESIS

Academic Year: 2017 - 2018

Supervisor: Dr D J CARR

MAY 2018

CRANFIELD UNIVERSITY

DEFENCE ACADEMY

CENTRE FOR DEFENCE ENGINEERING

PhD THESIS

Academic Year 2017-2018

MARK HELLIKER
Student Number 606174

Degradation of Fabrics used in Military Fragment Protective
Clothing Due to Selected Laundering Regimes

Supervisor: Dr D J Carr

May 2018

© Crown Copyright 2018. All rights reserved. No part of this
publication may be reproduced without the written permission of
the copyright holder.

ABSTRACT

With the introduction of fragment protective fabrics into combat clothing, there was a need to understand the effect of laundering on the performance of these fabrics. This thesis investigated the effect of typical laundering regimes on selected ballistic protective fabrics representative of those suitable for clothing applications. This study presents evidence that knitted silk and felted ultra-high molecular weight polyethylene retained their ballistic protective performance after laundering. The para-aramid fabrics showed significant improvement from laundering. The dimensional stability of the selected fabrics was affected by laundering and the effect was cumulative. The damage imparted to the fibres was determined to be due to mechanical wear. This mechanical wear was significantly increased when the fabrics were wet. This was due to the water increasing the friction between fibres during the laundering process. The fabrics investigated were shown to be suitable for use in fragment protective clothing, and were more robust than was generally considered.

Key Words:

Ballistic testing, para-aramid, silk, UHMWPE, woven, knit, felt, dimensional stability, wash, water

ACKNOWLEDGEMENTS

The completion of this research was only possible by the contribution and support by the following individuals and organisations:

- Dr Debra Carr, my PhD supervisor, who has guided, advised and supported me throughout the whole work and shown great patience to an over exuberant student.
- Heather Elsley of the then Dstl Programme Office, for funding the work through the core research programme.
- Adrian Randall and Mike Harris of the Defence Clothing Delivery Team DE&S, for providing materials and clothing for assessment, for helping ensure that the output from this work supported current UK procurement of equipment and supporting the work throughout.
- Professor Ian Horsfall and Steve Champion for their advice and support in ensuring this thesis met the requirements of a PhD.
- Claire Lankester, Mike Teagle and Leigh Fenton for their perseverance and reliability in the conduction of the ballistic testing for this work.
- Ralph Mansson of Dstl for his support with advice on the statistical analysis and development of the Critical Perforation Analysis (CPA).
- Liz Girvan of Otago University for providing the excellent FESEM images, used in the analysis of the fabrics.

- Guillaume Kister and Niki Darcy of Cranfield University for conducting the FTIR measurements and helping with the interpretation of the results.
- Dr Simon Holden, the Dstl mentor and technical lead for the body armour research programmes within the Physical Sciences Group, Dstl.
- Dr Aimée Helliker and Mrs Sarah Lister for reviewing and proof reading the thesis manuscript.

CONTENTS

ABSTRACT	i
ACKNOWLEDGEMENTS	ii
CONTENTS	iv
LIST OF FIGURES.....	vii
LIST OF TABLES.....	x
GLOSSARY	xii
ABBREVIATIONS	xxv
1 INTRODUCTION.....	1
1.1 Overview	1
1.2 Thesis structure	8
1.3 References.....	13
2 AIMS AND OBJECTIVES	19
2.1 Aims.....	19
2.2 Objectives	19
2.3 Fabrics and laundering regimes.....	20
2.3.1 Fabrics.....	21
2.3.2 Laundering regimes	22
2.4 References.....	24
3 EFFECT OF DOMESTIC LAUNDERING ON THE FRAGMENT PROTECTIVE PERFORMANCE OF FABRICS USED IN PERSONAL PROTECTION.....	25
3.1 General	25
3.2 Introduction	27
3.3 Materials and methods.....	28
3.4 Results and discussion	33
3.5 Conclusions	43
3.6 Acknowledgments.....	44
3.7 References.....	45
4 EFFECT OF WASH TEMPERATURE AND DURATION IN DOMESTIC LAUNDERING IN COMPARISON WITH AND IMPROVISED WASHING METHOD ON THE FRAGMENT PROTECTIVE PERFORMANCE OF FABRICS USED IN PERSONAL PROTECTION	49
4.1 General	49
4.2 Introduction	52
4.3 Materials and methods.....	56
4.3.1 Excursions	58
4.3.2 Change in ballistic performance.....	61
4.3.3 Modified ball burst test.....	64
4.3.4 FTIR.....	65
4.3.5 FESEM	66
4.4 Results.....	68
4.4.1 Ballistic results	68
4.4.2 Dimensional stability	70

4.4.3	Change in mass per unit area and thickness of fabric	73
4.4.4	Ball burst strength.....	76
4.4.5	FTIR.....	77
4.4.6	FESEM	78
4.5	Discussion.....	84
4.5.1	Knitted silk.....	84
4.5.2	Felted UHMWPE.....	85
4.5.3	Woven Para-aramid	86
4.6	Conclusions	87
4.7	Acknowledgments.....	89
4.8	References.....	90
5	THE CONTRIBUTION OF MOISTURE TO THE MECHANICAL WEAR AND DEGRADATION OF PERFORMANCE OF FRAGMENT PROTECTIVE FABRICS USED IN PERSONAL PROTECTION.....	95
5.1	General.....	95
5.2	Introduction	97
5.3	Materials and methods.....	100
5.3.1	Excursions	102
5.3.2	Change in ballistic performance.....	105
5.3.3	Modified ball burst test.....	107
5.3.4	FTIR.....	108
5.3.5	FESEM	109
5.4	Results.....	110
5.4.1	Ballistic testing	110
5.4.2	Change in dimension, thickness and mass per unit area.....	112
5.4.3	Modified ball burst strength results	116
5.4.4	FTIR.....	118
5.4.5	FESEM	118
5.5	Discussion.....	128
5.6	Conclusions	131
5.7	Acknowledgments.....	132
5.8	References.....	133
6	DISCUSSION.....	141
6.1	Introduction	141
6.2	Mechanisms by which fabrics stop fragments.....	141
6.2.1	Woven fabrics	143
6.2.2	Felted fabrics	146
6.2.3	Knitted fabrics	148
6.3	Effect of laundering on the fibres	151
6.3.1	Silk.....	151
6.3.2	UHMWPE	153
6.3.3	Para-aramid.....	154
6.4	Effect of laundering on the mechanisms by which fabrics stop fragments	157
6.4.1	Woven fabrics	158

6.4.2	Felted fabrics	161
6.4.3	Knitted fabrics	163
6.5	Effect of laundering on other fabric properties	165
6.5.1	Woven.....	165
6.5.2	Felted.....	166
6.5.3	Knitted.....	167
6.6	Effect of laundering regimes	167
6.7	Summary.....	169
6.8	References.....	173
7	CONCLUSIONS.....	179
8	FUTURE WORK	181
8.1	Determining the point at which ballistic protective performance of selected fabrics degrades through laundering	181
8.2	Determining the effect of laundering on the ballistic protective properties of selected fabrics from other threats.....	181
8.3	Can body armour fabrics be improved through conditioning with mechanical wear	181
8.4	Characterising the performance of knitted fragment protective fabrics for light weight applications.....	182
8.5	Assessment of the change in comfort properties of selected fabrics for clothing applications	182

LIST OF FIGURES

Figure 1-1 Combat Body Armour 1989 to present (left) and OSPREY Body Armour 2005 to present (right) (Crown Copyright 2012)	2
Figure 1-2 Tier 1 PPS introduced 2009 (left) Enhanced Protection UBACS introduced 2014 (right) (Crown Copyright 2012)	4
Figure 1-3 Wound mapping of 54 casualties from Afghanistan 2012; wearing PPS (A) (39 cases), without PPS (B) (15 cases) (Crown Copyright 2015)	5
Figure 1-4 Thesis structure	12
Figure 3-1 a) Tier 1 PPS b) EP-UBACS Concept Demonstrator	27
Figure 3-2 Typical specimen mounted for ballistic testing	29
Figure 3-3 Range set-up used in the ballistic trials (Copyright 2017, Cranfield University Media).....	31
Figure 3-4 FESEM images of silk before and after laundering	39
Figure 3-5 FESEM images of UHMWPE before and after laundering	40
Figure 3-6 FESEM images of felted para-aramid before and after laundering	41
Figure 3-7 FESEM images of woven para-aramid before and after laundering.....	42
Figure 4-1 Tier 1 Pelvic Protection (left) and EP-UBACS (right) (Crown Copyright 2012)	53
Figure 4-2 Laundry equipment including cement mixer, trough and buckets, typically used in UK forward operating base- Afghanistan (Crown Copyright 2010)	56
Figure 4-3 Example Test Specimen	58
Figure 4-4 Example of laundering with the cement mixer.....	60
Figure 4-5 Range set-up used in the ballistic trials (Copyright 2017, Cranfield University Media).....	63
Figure 4-6 Experimental setup for the ball burst test (Copyright 2017, Cranfield University Media).....	65
Figure 4-7 Silk (x35 magnification) NL (a), L40 (b), L90 (c), L90E (d) and CM (e) ...	79
Figure 4-8 Silk (x500 magnification) NL (a), L40 (b), L90 (c), L90E (d) and CM (e) .	79
Figure 4-9 Silk (x2000 magnification) NL (a), L40 (b), L90 (c), L90E (d) and CM (e)	79
Figure 4-10 UHMWPE (x35 magnification) NL (a), L40 (b), L90 (c), L90E (d) and CM (e).....	81
Figure 4-11 UHMWPE (x500 magnification) NL (a), L40 (b), L90 (c), L90E (d) and CM (e)	81

Figure 4-12 UHMWPE (x2000 magnification) NL (a), L40 (b), L90 (c), L90E (d) and CM (e)	81
Figure 4-13 Para-aramid (x35 magnification) NL (a), L40 (b), L90 (c), L90E (d) and CM (e)	83
Figure 4-14 Para-aramid (x500 magnification) NL (a), L40 (b), L90 (c), L90E (d) and CM (e)	83
Figure 4-15 Para-aramid (x2000 magnification) NL (a), L40 (b), L90 (c), L90E (d) and CM (e)	83
Figure 5-1 Tier 1 Pelvic Protection (left) and EP-UBACS (right) (Crown Copyright 2012)	98
Figure 5-2 Example Sample Panel.....	102
Figure 5-3 Range set-up used in the ballistic trials (Copyright 2017, Cranfield University Media).....	106
Figure 5-4 Experimental setup for the ball burst test (Copyright 2017, Cranfield University Media).....	108
Figure 5-5 SEM Images (x35) silk not-laundered (a), laundered (b), tumbled only (c) and washed only (d)	120
Figure 5-6 SEM Images (x500) silk not-laundered (a), laundered (b), tumbled only (c) and washed only (d)	121
Figure 5-7 SEM Images (x2000) silk not-laundered (a), laundered (b), tumbled only (c) and washed only (d)	122
Figure 5-8 SEM Images (x35) UHMWPE felt not-laundered (a), laundered (b), tumbled only (c) and washed only (d).....	123
Figure 5-9 SEM Images (x500) UHMWPE felt not-laundered (a), laundered (b), tumbled only (c) and washed only (d).....	124
Figure 5-10 SEM Images (x2000) UHMWPE felt not-laundered (a), laundered (b), tumbled only (c) and washed only (d).....	125
Figure 5-11 SEM Images (x35) woven para-aramid not-laundered (a), laundered (b), tumbled only (c) and washed only (d).....	126
Figure 5-12 SEM Images (x500) woven para-aramid not-laundered (a), laundered (b), tumbled only (c) and washed only (d)	127
Figure 5-13 SEM Images (x2000) woven para-aramid not-laundered (a), laundered (b), tumbled only (c) and washed only (d)	128
Figure 6-1 Example of ballistic impact of a 0.24 g chisel nosed FSP travelling at 237 m·s ⁻¹ into woven para-aramid fabric (image from high speed video)	144
Figure 6-2 Example of ballistic impact of a 0.24 g chisel nosed FSP travelling at 298 m·s ⁻¹ into felted UHMWPE fabric (image from high speed video)	148

Figure 6-3 Example of ballistic impact of a 0.24 g chisel nosed FSP travelling at 228 m·s ⁻¹ into knitted silk fabric (image from high speed video)	150
Figure 6-4 Example of degradation to silk fibres; not-laundered from Chapter 3 (left), laundered 27 cycles at 40 °C from Chapter 3 (Centre) and laundered 27 cycles at 40 °C from Chapter 4 (right)	152
Figure 6-5 Example of degradation to UHMWPE fibres; not-laundered from Chapter 3 (left), laundered 27 cycles at 40 °C from Chapter 3 (Centre) and laundered 27 cycles at 40 °C from Chapter 4 (right)	154
Figure 6-6 Example of degradation to para-aramid fibres; not-laundered from Chapter 3 (left), laundered 27 cycles at 40 °C from Chapter 3 (Centre) and laundered 27 cycles at 40 °C from Chapter 4 (right)	156
Figure 6-7 Change in ballistic protective performance for woven para-aramid against laundering cycles.....	160
Figure 6-8 Performance of woven para-aramid due to laundering (from Chapter 3)	161
Figure 6-9 Performance of para-aramid felt due to laundering (Chapter 3).....	162
Figure 6-10 Performance of UHMWPE felt due to laundering (from Chapter 3).....	163
Figure 6-11 Performance of knitted silk due to laundering (from Chapter 3)	164

LIST OF TABLES

Table 3-1 Summary data of relative ballistic performance compared to baseline	34
Table 3-2 Changes in physical properties for silk	36
Table 3-3 Changes in physical properties for UHMWPE	36
Table 3-4 Changes in physical properties for felted para-aramid	37
Table 3-5 Changes in physical properties for woven para-aramid	37
Table 4-1 Summary of laundering excursions	60
Table 4-2 Visual Assessment of Damage to Fabric from BS EN ISO 12945-2:2000	67
Table 4-3 Visual Assessment of Damage from FESEM Imagery	68
Table 4-4 V ₅₀ Results	70
Table 4-5 Dimensional change in panel X direction	72
Table 4-6 Dimensional change in panel Y direction	73
Table 4-7 Dimensional change in panel thickness	73
Table 4-8 Mass per unit area of the selected fabrics.....	75
Table 4-9 Thicknesses of the selected fabrics	76
Table 4-10 Ball burst strength	77
Table 5-1 Summary of laundering excursions	103
Table 5-2 Visual Assessment of Damage from FESEM Imagery	110
Table 5-3 Summary of ballistic performance compared to baseline	111
Table 5-4 Dimensional change in panels in X direction.....	113
Table 5-5 Dimensional change in panels in Y direction.....	113
Table 5-6 Dimensional change in panel thickness	114
Table 5-7 Change in mass per unit area of fabrics for each condition	114
Table 5-8 Change in thickness of fabrics for each condition	115
Table 5-9 Modified ball burst strength test results for silk, UHMWPE and para-aramid	118
Table 6-1 Change in performance of woven and felted para-aramid fibres due to laundering (Chapter 3).....	157
Table 6-2 Relative performances of unconditioned knitted and woven fabrics tested backed and unbacked (“knitted backed” used as baseline).....	165
Table 6-3 Relative change in performance of para-aramid laundered at 40 °C for 27 cycles (Chapters 3 and 4).....	169

GLOSSARY

Areal Density	The mass per unit area of the armour or armour material. The units in this thesis are expressed as $\text{kg}\cdot\text{m}^{-2}$ (Laible, 1980).
Behind Armour Blunt Trauma (BABT)	Behind Armour Blunt Trauma measurement to assess risk of injury from behind armour deformation (Cannon, 2001).
Course	In the knitted fabric used in this study, the course is a row of loops that are made around the circumference of the knitted tube (Denton et al., 2002).
Critical Perforation Analysis	Critical perforation analysis is a generic term used to describe a range of statistical methods used to estimate the limit of protection of an armour or material from perforation by a projectile. Typically the term is abbreviated to CPA and refers to logistic regression methods such as probit (Bliss, 1934, Leeming et al., 2002).

Decitex

Tex is a unit of measure for the linear mass density of fibres and is defined as the mass in grams per 1000 metres. Tex is more likely to be used in Canada and Continental Europe, while denier remains more common in the United States and United Kingdom.

The unit code is "tex". The most commonly used unit is the decitex, abbreviated dtex, which is the mass in grams per 10,000 metres. When measuring objects that consist of multiple fibres the term "filament tex" is sometimes used, referring to the mass in grams per 1000 metres of a single filament (Denton et al., 2002).

Denier

Denier or den is a unit of measure for the linear mass density of fibres. It is defined as the mass in grams per 9,000 metres. In the International System of Units the tex is used instead (see below). The denier is based on a natural standard: a single strand of silk is approximately one denier (Denton et al., 2002).

Double Jersey Interlock knit A double jersey interlock knit is a knitted fabric made on an interlock basis, and is designed to reduce natural extensibility and provide a more durable fabric (Denton et al., 2002).

Fabric An assembly of fibres or yarns into a structure that has a large surface area in comparison with its thickness. The fabric is characterised as having sufficient cohesion to provide it with suitable mechanical strength (Denton et al., 2002).

In the context of this thesis the term fabric has been used to describe a single layer of fabric or specific properties of it. The term sample panel has been used to describe the combination of the layers of fabric under investigation within a cover fabric, as a final article.

Fair Hit

A projectile impacting a location on the armour that is deemed to not have been unduly influenced by a previous impact or edge of a panel. MIL-STD_662F defines it as a projectile impacting un-yawed, at a specified obliquity and not within two projectile diameters from a previous impact, damage from a previous impact or the edge of a panel. (Department for Defence, 1997).

Felt

Felts are formed from the entanglement of fibres to form a fabric. They can be formed from woven or knitted fabric, or can be formed from pressing fibres together. In this study the felts have been formed by entangling fibres into a batt using either needles or water jets (Denton et al., 2002).

Fibre

A fibre is the basic component of a yarn or fabric and is characterised by a high length to diameter ratio. The fibres properties are characterised by flexibility and fineness (Denton et al., 2002).

Fibrillation	The splitting of a fibre's in the longitudinal direction (Denton et al., 2002).
Fibrils	The structural sub-units of a fibre and can be formed from bundles of linear polymer bundles (Denton et al., 2002).
Fineness	The fineness of a fibre is measured by its denier or dtex value and is a fundamental property of the fibre that greatly influences its use (Taylor, 2007).
Fragment Simulating Projectile (FSP)	A projectile of various masses and composition, used to represent fragments from fragmenting munitions. FSP can be of various geometries from cylinders, cubes or spheres. This study used a Chisel Nosed FSP made from HRC 30 steel of 0.24 g in mass (SCRDE, 1993).

Hydro-entangled	Hydro-entanglement is a method of felting a fabric using water jets instead of the more traditional use of needle punching. The use of jets is believed to reduce the damage to the fibres during the felting process (Russell et al., 2005).
Loom state	The condition of a fabric as it comes off the loom before any treatments or conditioning is applied (Denton et al., 2002).
Para-aramid	Para-aramids are a man-made polyamide fibre that is characterised as having highly orientated chains of molecules. Aramid fibres are highly flame retardant and have a high strength to weight ratio (Taylor, 2007).
Penetration	The projectile has passed part way through the thickness of the armour and is not protruding/ cannot be seen from the rear face (Baker et al., 2010).
Perforation	The projectile has passed through the complete thickness of the armour – this is sometimes referred to as a Complete Penetration (Baker et al., 2010).

Pilling	Pilling is formed by the entanglement of fibres such that they form balls (or pills) on the surface of the fabric. This is often caused by the laundering process (Denton et al., 2002).
Plain Weave	A plain weave is the simplest weave where a warp yarn is woven over and under each alternate weft yarn (Denton et al., 2002).
Quilting	Quilting is a series of stitch lines through one or more layers of fabric at regular intervals. The quilting may be used to stop the movement of layers of fabric in relation to others.
Sample Panel	Within the context of this thesis, the term sample panel refers to the combination of the layers of fabric under investigation within a cover fabric, as a final article. This was to distinguish between the analysis on a representative final article and the analysis on the fabrics under investigation within this study.

Scoured	The term used to describe the state of a fabric after lubricants and other impurities have been removed. This is usually by means of washing the fabric in a water or solvent solution (Denton et al., 2002).
Shrapnel	Steel spheres first incorporated into artillery shells by Lt Col Henry Shrapnel in the 18 th Century.
Silk	Silk is the filaments extracted from the silkworm cocoon (Denton et al., 2002).
Single Jersey Knit	A single jersey knit is a weft knitted fabric that are made using a single set of needles (Denton et al., 2002).
Soft Armour Insert	The portion of an armour system that is generally composed of flexible panels (e.g., the front and back panels in the armour carrier) made of layers of woven ballistic fabrics, offering protection levels for low mass fragments and low velocity small arms projectiles (Baker et al., 2010).

Tenacity

Tenacity (Yarn Strength) is the customary measure of strength of a fibre or yarn. In the U.S. it is usually defined as the ultimate (breaking) strength of the fibre (in gram-force units) divided by the denier. Because denier is a measure of the linear density, the tenacity works out to be not a measure of force per unit area, but rather a quasi-dimensionless measure analogous to specific strength (Denton et al., 2002).

Ultra-high molecular weight polyethylene

Ultra-high molecular weight polyethylene is a gel spun fibre which is drawn in order to orient the molecules. This results in a high modulus, high tenacity fibre, which performs well in ballistic protection applications. The most common fibres are Spectra produced by Honeywell and Dyneema produced by DSM (Scott, 2005).

V_0

The V_0 is the highest velocity at which the probability of a perforation of the specified armour with the specified projectile is 0 % (North Atlantic Treaty Organisation, 2003).

V_{50}	The velocity at which the probability of a perforation of the specified armour with the specified projectile is 50 % (North Atlantic Treaty Organisation, 2003).
Wale	In a knitted fabric the wale is defined as the column of loops along the length of the fabric (Denton et al., 2002).
Warp	When weaving cloth, the warp is the set of lengthwise yarns that are held in tension on a frame or loom. The yarn that is inserted over-and-under the warp thread is called the weft, woof, or filler. Each individual warp thread in a fabric is called a “warp end” or “end”. As the warp is held under high tension during the entire process of weaving, warp yarns must be strong. Yarn for warp ends is usually spun and plied fibre (Denton et al., 2002).

Weft

When weaving cloth the weft or wale is the term for the yarn which is drawn through the warp yarns across the width to create cloth. Warp yarns are the longitudinal thread in a roll, while weft is the transverse thread. A single thread of the weft, crossing the warp, is called a pick. Terms do vary, for instance in North America, the weft is sometimes referred to as the fill or the filling yarn. Because the weft does not have to be stretched on a loom in the way that the warp is, it can generally have less strength. The weft is threaded through the warp using a shuttle, air jets or rapier grippers (Denton et al., 2002).

Yarn

A yarn is a collection of fibres or filaments to form a continuous length of material with or without twist (Denton et al., 2002).

References

- Baker, L. J., Helliker, M. & Holden, S. J. 2010. Dstl Personal Physical Protection Ballistic Test Protocol v1.0. DSTL/CR43742. Defence Science and Technology Laboratory. Dstl Porton Down.
- Bliss, C. I. 1934. The method of probits. *Science*, 79(2037):38-39.
- Cannon, L. 2001. Behind Armour Blunt Trauma - an emerging problem. *Journal of the Royal Army Medical Corps*, 147:87-96.
- Denton, M. J. & Daniels, P. N. 2002. *Textile Terms and Definitions*, Manchester, UK, The Textile Institute.
- Department for Defence. MIL-STD-662F V₅₀ ballistic test for armor. 1997.
- Laible, R. C. 1980. *Ballistic materials and penetration mechanics*, Elsevier Scientific Pub. Co.
- Leeming, D. W., Quelch, L. J., Fenn, P. M., et al. 2002. Fundamental Data and Analysis on the Penetration Resistance of a Textile Armour. *Personal Armour Systems Symposium*. Netherlands: IPAC.
- North Atlantic Treaty Organisation. STANAG 2920 Edition 2: Ballistic Test Method for Personal Armour Materials and Combat Clothing. 2003.
- Russell, S. J., Pourmohammadi, A., Ezra, I., et al. 2005. Formation and properties of fluid jet entangled HMPE impact resistant fabrics. *Composites Science and Technology*, 65(6):899-907.

Scott, R. A. 2005. *Textiles for Protection*, Cambridge, UK, Woodhead Publishing in Textiles.

SCRDE. A3/6723 - Fragment Simulating Projectile. 1993. A3/6723/3.

Taylor, M. A. 2007. *Technology of Textile Properties*, Forbes Publications.

ABBREVIATIONS

%	Percentage
°C	Degrees Celsius
ANOVA	Analysis of Variance
BABT	Behind Armour Blunt Trauma
BR GLM	Bias Reduced Generalised Linear Model
CM	Laundered in a Cement Mixer (in Chapter 4)
CN	Chisel Nosed
CPA	Critical Perforation Analysis
DC DT	Defence Clothing Delivery Team
DE&S	Defence Equipment & Support
DOP	Degree of Polymerisation
DSTL	Defence Science and Technology Laboratory
E_{abs}	Energy absorbed
EDS	Energy Dispersive x-ray Spectroscopy
EP-UBACS	Enhanced Protection Under Body Armour Combat

	Shirt
FESEM	Field Emission Scanning Electron Microscope
FSP	Fragment Simulating Projectile
FTIR	Fourier Transform Infra-Red
g	Grammes
$\text{g}\cdot\text{m}^{-2}$	Grammes per square metre
GLM	Generalised Linear Model
IED	Improvised Explosive Device
J	Joules
kg	Kilograms
$\text{kg}\cdot\text{m}^{-2}$	Kilograms per square metre
l	Litres
L	Laundered at 40 °C for 52 cycles (in Chapter 5)
L40	Laundered at 40 °C for 27 cycles (in Chapter 4)
L90	Laundered at 90 °C for 27 cycles (in Chapter 4)
L90E	Laundered at 90 °C for 45 cycles (in Chapter 4)

m	Metres
m·s ⁻¹	Metres per second
min	Minutes
MIR	Mid Infra-Red
mm	Millimetres
N	Newtons
Nm	Newton meters
NIR	Near Infra-Red
NL	Not-laundered
PPS	Pelvic Protection System
R.H.	Relative Humidity
s	Seconds
SD	Standard Deviation
SE	Standard Error
T	Tumbled only (in Chapter 5)
UHMWPE	Ultra-high molecular weight polyethylene

UOR Urgent Operational Requirement

W Washed only (in Chapter 5)

WWI World War I

WWII World War II

1 INTRODUCTION

1.1 Overview

UK military operations in Afghanistan between 2006 and 2014 changed the focus of personal protection provided to H.M. Armed Forces. Prior to 2008, personal fragment protection took the form of a combat helmet and combat body armour (Figure 1-1). The combat body armour weighed approximately 3 kg (depending on size, excluding ballistic plate inserts) (Marsden, 1994). The fabric components of the body armours which saw service with the UK Armed Forces in Afghanistan added mass and bulk to the dismounted soldier. The areal density varied between 3.8 and 4.5 kg·m⁻², leading to body armour that could weigh in excess of 8 kg (not including the ballistic plate inserts for high velocity bullet protection) (Figure 1-1) (Ministry of Defence, 1989, 2008). These systems were designed to provide protection against 1.1g chisel nosed fragment simulating projectiles (FSPs; the mass of which in UK specifications range from 0.16 g to 2.8 g, with the most commonly used being 1.1 g in mass) to represent fragments from conventional fragmenting munitions (Ministry of Defence, 1993). Fragmenting threats have traditionally been the most common cause of battlefield casualties through modern warfare e.g. (Dean, 1920, Herget, 1964, Ryan et al., 1991, Bowyer, 1997, Dougherty et al., 2009). In all conflicts of the 20th Century since the beginning of WWI, the greater proportion of fragment injuries recorded were seen to the limbs. This is in contrast to fatalities from fragmentation which were

predominantly caused by fragment injuries to the head, neck and torso (Dean, 1920, Ryan et al., 1991). In Iraq (2003 to 2008) and in Afghanistan an increasing proportion of injuries were seen to the lower limbs from a change in the preferred methods of attack in that operation e.g. (Dougherty et al., 2009, Eskridge et al., 2012, Evans et al., 2012, Brogden, 2013, Uppal et al., 2013, Ramasamy et al., 2014, Keene et al., 2015).



Figure 1-1 Combat Body Armour 1989 to present (left) and OSPREY Body Armour 2005 to present (right) (Crown Copyright 2012)

UK operations in Afghanistan saw the threat from the insurgency shift from conventional warfare to a successful and well documented buried improvised explosive device (IED) campaign as documented by Ramasamy et al., 2008, Breeze et al., 2011a, Eskridge et al., 2012. Injuries from these types of devices were often characterised as traumatic amputation (typically of the lower limbs) and penetrating injuries into the pelvic ring and abdomen by metallic and non-metallic fragments

(Adams, 2010, Brogden, 2013, Sharma et al., 2013b, Breeze et al., 2015, Keene et al., 2015). As a result the most common threat to the soldier was no longer seen as metallic fragments of approximately 1 g. For example, an analysis of 110 UK casualties with neck injuries from operations in Afghanistan between 2008 and 2011, identified that the majority of fragments (approximately 80%) were less than 0.5 g (Breeze et al., 2013b). Other research suggested that the majority of fragments in warfare from WWI through to the Falklands conflict had low energy and rarely passed completely through body (Dean, 1920, Ryan et al., 1991). This suggests that the fragments were small and of relatively low velocity (i.e. sub-sonic) (Dean, 1920). This would imply that a low level of fragment protection covering a larger proportion of the body could be effective in reducing the number or severity of fragment injuries (Sakaguchi et al., 2009).

In 2009, an accelerated research programme was initiated within the Defence Science and Technology Laboratory (DSTL) and the Defence Clothing Delivery Team (DC DT) within Defence Equipment and Support (DE&S) of the UK Ministry of Defence (MOD) (Defence Science and Technology Laboratory, 2010). It was identified that a low level of protection to the lower abdomen, perineum, genitals, anus and buttocks provided by a pair of silk lined shorts (Tier 1 Pelvic Protection System; PPS) might reduce the severity of the injuries sustained (Figure 1-2) (Sharma et al., 2013a, Uppal et al., 2013).



Figure 1-2 Tier 1 PPS introduced 2009 (left) Enhanced Protection UBACS introduced 2014 (right) (Crown Copyright 2012)

An analysis of 54 casualties amongst UK and other NATO forces was conducted, where 39 were wearing the PPS (Tier 1 in all cases and Tier 2 for UK forces only – undisclosed number) (Breeze et al., 2015). A graphic wound mapping tool was used to compare the prevalence and location of injury to the pelvic region (Figure 1-3). The image clearly demonstrates the effectiveness of the PPS system in reducing the severity of injuries to this region. The red dots denote a perforating wound requiring surgical excision, blue triangles represent small fragments that were not removed or removed via scrubbing and the green discs denote traumatic amputation of the limb. The graphic (A) clearly shows that where the PPS covers the body, there are few fragment injuries. In contrast, the graphic (B) shows a more uniform spread of fragment injuries across the upper legs and pelvic region from these incidents.

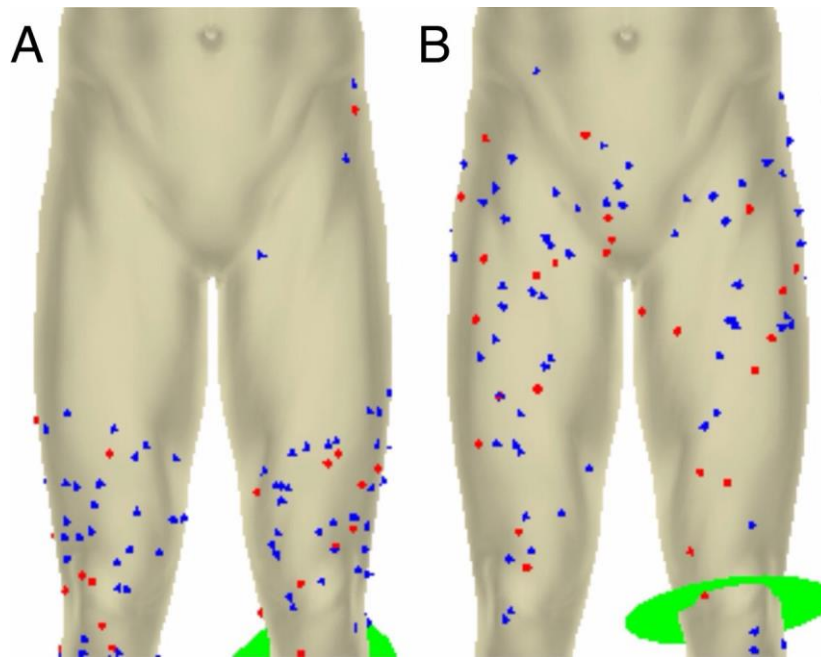

Figure 1-3 Wound mapping of 54 casualties from Afghanistan 2012; wearing PPS (A) (39 cases), without PPS (B) (15 cases) (Crown Copyright 2015)

The Tier 1 PPS was introduced into service as an Urgent Operational Requirement (UOR)¹ and first saw operational use in 2010 (Lewis et al., 2013). This was the first example of fragment protection being integral to an item of UK military clothing, as averse to a garment whose sole function was to provide ballistic protection (such as body armour). All deployed personnel on operations in Afghanistan were issued with at least four sets of the Tier 1 PPS each, which at the time numbered over 8,500 soldiers, sailors and airmen. The typical tour length for the Army was 6 months and 4 months for the Royal Airforce and Royal Navy. This resulted in over 68,000 sets of

¹ An UOR is a process used to procure equipment quickly for a specific operation. Typically a period of six months is given from the UOR being signed off and the equipment being brought into service for that operation. This process circumvents many of the requirements for equipment procurement programmes in order to bring it into service quickly.

Tier 1 PPS being issued each year. The cost of the Tier 1 PPS was not inconsiderable and was approximately ten times the cost of the previously issued underwear, mainly due to the high cost of the silk².

Following the success of the Tier 1 PPS (Breeze et al., 2015), the collar of the Under Body Armour Combat Shirt (UBACS) was re-enforced with a layer of hydro-entangled ultra-high molecular weight polyethylene (UHMWPE) felt, and termed the Enhanced Protection UBACS (EP-UBACS) (Figure 1-2). This was to provide additional protection to vulnerable structures within the neck from small low velocity fragments (Breeze et al., 2011b, Breeze et al., 2013a, Breeze et al., 2014).

The introduction of the Tier 1 PPS and later the EP-UBACS raised questions as to the robustness and durability of fibres, yarns and fabrics used in fragment protective clothing. As next-to-skin wear, Tier 1 and EP-UBACS had to be capable of being laundered for hygiene reasons. Until this point, fragment protective garments had not routinely been laundered and there was no research available on the effect of laundering on the fragment protective fabrics used. Fragment protective fabrics have long been known to be adversely affected by the presence of water e.g. (Morrison et al., 1978, Morrison, 1984, Bazhenov, 1997, DHB Armor Group, 2004). The effect of water has been identified as a mechanical one, increasing inter-yarn friction, whilst reducing friction between the projectile and the fabric (Bazhenov et al., 1999, Li et

² Figures based on discussions with the Technical Manager for Defence Clothing Delivery Team, DE&S. The cost of the silk can be as high as £15 per linear metre, compared to a typical cost of £7 - 9 for many para-aramids.

al., 2015). As a consequence, the performance can be returned when the fabric is dried and no long term effects have been noted for para-aramids or UHMWPE. An exception to this was in the case of Zylon™ where a chemical change was observed as a result of variable cleaning techniques of the fibre in production which affects fragment protective performance (Iremonger et al., 2002, Walsh et al., 2006). For these reasons, many body armour systems incorporating fragment protective fabrics have included a water resistant cover (typically a coated plain woven polyester).

Little research has been conducted on the long term robustness of body armour and the only published guidance on the suggested replacement policy for body armour was published by Du Pont (reproduced in (DHB Armor Group, 2004)). More recent research has been presented, but has not been conclusive (Withnall et al., 2010, Pinto et al., 2011, Bourget et al., 2012). Neither in the Du Pont work nor the subsequent research were clear trends between age and long term performance identified. A possible cause for this was described as being the variability in amount of times and duration that each of those armours were worn. It was not possible in the Du Pont study to determine the level at which the armours had been worn, which suggests that the degradation of the armours was more greatly affected by the amount of wear of the armour than by its age alone.

Laundering is known to be one of the most aggressive factors in the degradation of fabrics e.g. (Eisenhut, 1941, Hördler et al., 1976, Slater, 1991, Van Amber et al.,

2010). The effect of laundering varies among fibre and fabric structure type and laundering regime. There is therefore a need to understand the effect of laundering on the ballistic performance of fabrics and in particular for fabrics that are not usually laundered (such as para-aramid and UHMWPE).

In order to understand the long term robustness of these items of protection a research programme within DSTL was initiated to investigate the effect of laundering on fabrics suitable for use in fragment protective clothing. This thesis is the presentation of this work, which has been used to inform the development, care and replacement of such items of protection (Lewis et al., 2013, Breeze et al., 2014).

1.2 Thesis structure

This thesis presents the results of the research conducted as three research papers and meets the requirements of a Cranfield University 'papers' thesis. Chapter 1 provides an overview of the background to the work conducted and describes the structure of the thesis. Chapter 2 presents the aims and objectives of the research. Chapters 3, 4 and 5 are in the form of papers published or prepared for publication in international peer-reviewed literature. Each of these chapters has a short introduction explaining the relevance of the work and how it supports the research into the effect of laundering on the fragment protective properties of the fabrics under investigation as well as a declaration regarding the contributions of the primary author and the co-authors. Each of these chapters also includes a description of the

methods used in the chapter, which will be similar in each paper. Chapter 6 discusses the research, Chapter 7 provides conclusions and Chapter 8 suggests further work. Appendices provide information regarding the use of probit analysis in the estimation of the change in ballistic protective performance of the fabrics, the development of the modified ball burst test method and the raw data generated during the course of this study.

The structure of the thesis is:

Chapter 1 contains the background, aim and the structure of the thesis presented.

Chapter 2 details the aims and objectives of this thesis.

Chapter 3 contains research into the effect of one laundering regime on selected fabrics to replicate the durations typical of an operational tour in Afghanistan by British Forces. Results of 0.24g CN FSP ballistic testing are presented and analysis of ballistic performance, dimensional change and microscopy are made. This chapter is based on the paper published in the Textile Research Journal; **Helliker**, M., Carr, D.J., Lankester, C., Fenton, L., Girvan, L. & Horsfall, I. 2014. Effect of domestic laundering on the fragment protective performance of fabrics used in personal protection. Textile Research Journal 84: 1298-1306.

Chapter 4 compares the effect of laundering when the wash temperature is increased from a typical 40 °C wash to a “hot wash” at 90 °C, the effect of extended

laundering at 90 °C and the use of a Cement Mixer. It was identified that on operations in Afghanistan the hot wash was more typically employed, to kill bacteria that can cause odour or lead to skin conditions. In this chapter the effect of extending the 90 °C wash for the equivalent of nine months laundering was investigated. This temperature was chosen as it most closely replicated the laundering regimes that were used in Afghanistan by British Forces in main bases. It was also identified that some forward operating bases in Afghanistan were utilising cement mixer, with water heated to a temperature commensurate with that achievable with a solar shower, to launder clothes in the absence of normal laundering facilities. The effect of washing using a Cement Mixer was investigated to determine if the trends in wear identified previously in this study were particular to the regime used, or whether the effects were independent of method of laundering. This work was initiated in response to an urgent request for information from DE&S to inform operational planning and logistic resupply. The comparison of the degradation imparted by the two wash temperatures was assessed by 0.24g CN FSP ballistic testing, dimensional change, measurement of mass per unit area of the fabrics, fabric strength using a modified ball burst test, Fourier transform infra-red spectrometry and visual assessment through field emission scanning electron microscopy. This chapter is presented in a paper format ready for publication.

Chapter 5 contains research into the contribution of moisture in imparting mechanical wear typical in laundering. Comparison was made between laundering representative of 12 months and tumbling the fabrics dry and wet for equivalent durations of cycles. Results on the change in ballistic protective performance, dimensional change, ball burst strength and mass per unit area of the fabric are made and compared with analysis of microscopy.

Chapter 6 discusses the research presented in each of the chapters and how they answer the wider question of how laundering degrades the fabrics used in fragment protective clothing.

Chapter 7 presents the conclusions of the research and discusses the potential for further research in this field.

Chapter 8 presents suggested future work that should be conducted to further the knowledge in this field identified at the time of writing.

Appendix A – Statistical methods (Probit)

Appendix B – Development of a modified ball burst test

Appendix C – Results (on CD)

A flow diagram of the structure of the thesis is shown in Figure 1-4.

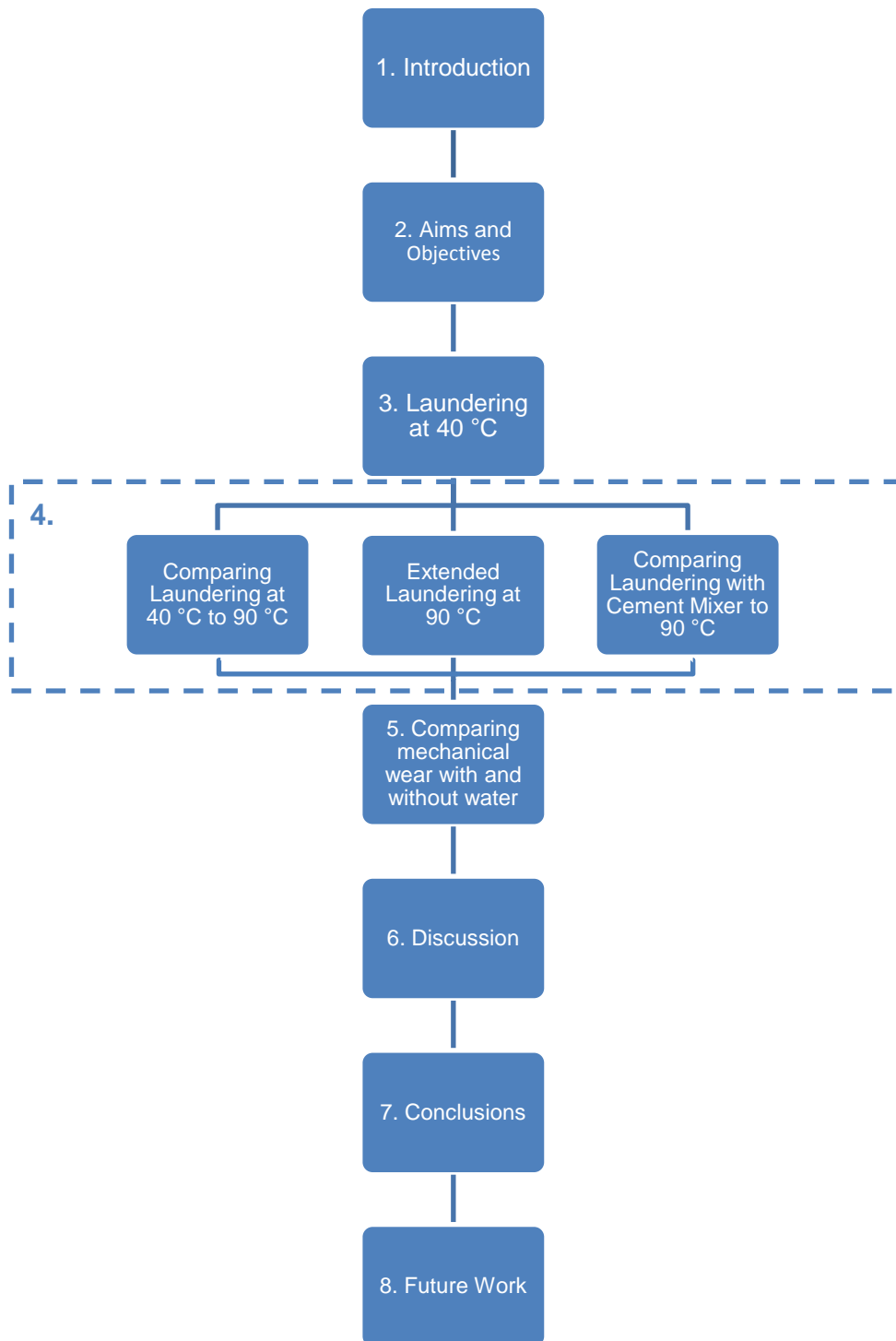

Figure 1-4 Thesis structure

1.3 References

- Adams, S. A. 2010. Pelvic Ring Injuries in the Military Environment. *Journal of the Royal Army Medical Corps*, 155(4):293-296.
- Bazhenov, S. L. 1997. Dissipation of energy by bulletproof aramid fabric. *Journal of Material Science*, 32:4167-4173.
- Bazhenov, S. L., Rozhkov, A. N., Kovalev, P. I., et al. 1999. Ballistic Tests of Aramid Armos and SVM Fabric Laminates. *Proceedings of the Novel Materials Workshop*. Cavendish Laboratory, Cambridge, UK: DERA.
- Bourget, D., Withnall, C., Palmer, S., et al. 2012. Aged Body Armour Testing: Further Results. *Personal Armour Systems Symposium 2012*. Nuremburg, Germany. .
- Bowyer, G. W. 1997. Fragment Wounds of Modern Warfare - Aspects of their Treatment. M Chir, University of Cambridge.
- Breeze, J., Allanson-Bailey, L. C., Hepper, A. E., et al. 2015. Demonstrating the effectiveness of body armour: a pilot prospective computerised surface wound mapping trial performed at the Role 3 hospital in Afghanistan. *Journal of the Royal Army Medical Corps*, 161:36–41.
- Breeze, J., Allanson-Bailey, L. S., Hunt, N. C., et al. 2011a. Mortality and morbidity from combat neck injury. *British Journal of Oral and Maxillofacial Surgery*, 49, Supplement 1(0):S23.
- Breeze, J., Granger, C. J., Pearkes, T. D., et al. 2014. Ergonomic assessment of enhanced protection under body armour combat shirt neck collars. *Journal of the Royal Army Medical Corps*, 160(1):32-37.

- Breeze, J., Helliker, M. & Carr, D. J. 2013a. An integrated approach towards future ballistic neck protection materials selection. *Proceedings of the Institution of Mechanical Engineers, Part H: Journal of Engineering in Medicine*, 227:581-587.
- Breeze, J., Horsfall, I., Hepper, A., et al. 2011b. Face, neck, and eye protection: adapting body armour to counter the changing patterns of injuries on the battlefield. *British Journal of Oral and Maxillofacial Surgery*, 49(8):602-606.
- Breeze, J., Leason, J., Gibb, I., et al. 2013b. Characterisation of explosively propelled fragments injuring the neck. *British Journal of Oral and Maxillofacial Surgery*, 51:79-106.
- Brogden, T. G. 2013. Anorectal injury in pelvic blast. *Journal of the Royal Army Medical Corps*, 159(Supp 1):i26–i31.
- Dean, B. 1920. Helmets and body armour in modern warfare, Yale University Press.
- Defence Science and Technology Laboratory. 2010. Annual Report and Accounts 2009/10. ISBN: 9780102967333. Defence Science and Technology Laboratory. Salisbury, UK.
- DHB Armor Group. 2004. DHB Armor Group Armor Safety Report. DHB Industries Inc. USA.
- Dougherty, A. L., Mohrle, C. R., Galarneau, M. R., et al. 2009. Battlefield extremity injuries in Operation Iraqi Freedom. *Injury*, 40(7):772-777.

- Eisenhut, O. 1941. Zur Frage der Bestimmung des Schädigungswertes von Fasern, Garnen oder Geweben aus Zellulose und von Zellstaffen. *Melliand Textilber*, 22:424-426.
- Eskridge, S. L., Macera, C. A., Galarneau, M. R., et al. 2012. Injuries from combat explosions in Iraq: Injury type, location, and severity. *Injury*, 43(10):1678-1682.
- Evans, S., Ramasamy, A., Kendrew, J., et al. 2012. The open blast pelvis: The burden of management. *International Journal of Surgery*, 10(8):S5.
- Herget, C. M. 1964. Chapter 12:Wound Ballistics and Body Armour in Korea.
- Hördler, J., Mizner, F. & Hetzer, R. 1976. Veränderung der Reißfestigkeit, des DP-Grades und des Schädigungs faktors nach mehrmaligem Waschen van Textilien. *Melliand Textilberichte*, 10:853.
- Iremonger, M. J. & Gotts, P. L. 2002. Practical Personal Ballistic Protection: Past, Present And Future. *Personal Armour Systems Symposium*.
- Keene, D. D., Penn-Barwell, J. G., Wood, P. R., et al. 2015. Died of wounds: a mortality review. *Journal of the Royal Army Medical Corps*, 0:1-6.
- Lewis, E. A., Pigott, M. A., Randall, A., et al. 2013. The development and introduction of ballistic protection of the external genitalia and perineum. *Journal of the Royal Army Medical Corps*, 159(Supp I):i15-i17.
- Li, Y., Li, C., Zheng, J., et al. 2015. Effects of water on the ballistic performance of para-aramid fabrics: three different projectiles. *Textile Research Journal*, 86(13):1372–1384.

Marsden, A. L. 1994. Current UK Body Armour and Helmets. *In: GOTTTS, P. L. & KELLY, P. M. (eds.) Personal Armour Systems Symposium*. Colchester, United Kingdom.

Ministry of Defence. Filler, Combat Body Armour. 1989. SCRDE/STR/0001.

Ministry of Defence. Drawing A3/6723 - Fragment Simulating Projectile. 1993.
A3/6723/3.

Ministry of Defence. 2008. Performance Specification for FILLER BODY ARMOUR OSPREY. DC/PS/6255 Issue 01. Defence Clothing Intergated Project Team. DE&S Caversfield, UK.

Morrison, C. E. 1984. The mechanical response of an aramid textile yarn to ballistic impact. PhD, University of Surrey.

Morrison, C. E. & Bowyer, W. H. 1978. Factors affecting ballistic impact resistance of Kevlar 49 reinforced composites. R762/1/August 1978. Fulmer Research Institute Limited.

Pinto, R., Carr, D. J., Helliker, M., et al. 2011. Degradation of military body armour due to wear: laboratory testing. *Textile Research Journal*, 82(11):1157-1163.

Ramasamy, A., Harrisson, S. E. & Stewart, M. P. M. 2008. Penetrating missile injuries during the Iraqi insurgency 2006. *Injury Extra*, 39(5):158.

Ramasamy, A., Hill, A. M. & Clasper, J. C. 2014. Improvised Explosive Devices: Pathophysiology, Injury Profiles and Current Medical Management. *Journal of the Royal Army Medical Corps*, 155(4):265-272.

- Ryan, J. M., Cooper, G. J., Haywood, I. R., et al. 1991. Field surgery on a future conventional battlefield: strategy and wound management. *Annals of the Royal College of Surgeons of England*, 73:13-20.
- Sakaguchi, S. M., Carr, D. J., Horsfall, I., et al. 2009. Protecting the extremities of military personnel: fragment protective performance of one- and two-layer ensembles. *Textile Research Journal*, 82(12):1295-1303.
- Sharma, D. M. & Bowley, D. M. 2013a. Immediate surgical management of combat-related injury to the external genitalia. *Journal of the Royal Army Medical Corps*, 159(Supp 1):i18–i20.
- Sharma, D. M., Webster, C. E., Kirkman-Brown, J., et al. 2013b. Blast injury to the perineum. *Journal of the Royal Army Medical Corps*, 159(suppl 1):i1-i3.
- Slater, K. 1991. *Textile degradation*, The Textile Institute.
- Uppal, L., P., A. & D., E. 2013. Complex lower genitourinary reconstruction following combat-related injury. *Journal of the Royal Army Medical Corps*, 159(Supp 1):i49–i51.
- Van Amber, R. R., Niven, B. E. & Wilson, C. A. 2010. Effects of Laundering and Water Temperature on the Properties of Silk and Silk-blend Knitted Fabrics. *Textile Research Journal*, 80(15):1557-1568.
- Walsh, P. J., Hu, X., Cunniff, P. M., et al. 2006. Environmental effects on poly-p-phenylenebenzobisoxazole fibers. I. Mechanisms of degradation. *Journal of Applied Polymer Science*, 102(4):3517-3525.

Withnall, C., Garland, L. & Bourget, D. 2010. Aged Body Armour Testing in
Development of a Replacement Protocol. *Personal Armour Systems
Symposium 2010*. Quebec, Canada. .

2 AIMS AND OBJECTIVES

2.1 Aims

The aim of the study was to determine the effect of selected laundering regimes on the fragment protective properties of the fabrics considered. The effect of laundering within a military context of a six month operational tour of duty and twelve months within a barracks environment was investigated, as this represents the current replacement policy for combat clothing. This was in order to inform the decision on the selection of fabrics suitable for incorporation within fragment protective clothing and the replacement policy to optimise funding. This work was funded by UK Ministry of Defence to support the through life capability management of the Tier 1 PPS and the EP-UBACS.

2.2 Objectives

The objectives of the study were to:

- Replicate different laundering regimes representative of operational environments (typically up to 27 laundering cycles or six months use: considering that four sets are typically issued) and domestic laundering in barracks (up to 52 laundering cycles or twelve months use). These durations were informed by current operational clothing replacement policy (Randall, 2013). An additional excursion investigating the effect of laundering with the use of a cement mixer was to be investigated.

- Determine the effect of these regimes on the ballistic protective properties of the fabrics against 0.24g chisel nosed fragment simulating projectiles.
- Determine the effect of laundering on the dimensional properties of the fabrics.
- To conduct visual analysis through FESEM of the fabrics, to inform the identification of the main causative agents in degradation through laundering.
- To conduct Fourier Transform Infra-Red Spectrometry on the selected fabrics to determine if any change in performance was due to a change in the chemical structure of the fibres.
- To assess the change in ball burst strength of selected fabrics as a result of laundering.

2.3 Fabrics and laundering regimes

As the development of the items of protection were conducted in short timescales as an UOR, the selection of fabrics and laundering regimes changed through the course of the work. The work presented in Chapter 3 was conducted as an initial investigation into the effects of laundering on candidate fabrics for these protective systems. Between the work being conducted in Chapter 3 and the subsequent chapters, the Tier 1 PPS was developed with support from industry. Samples of the fabrics used in the Tier 1 PPS and the EP-UBACS were obtained through DE&S and

subsequent work presented in Chapters 4 and 5 used these fabrics, as opposed to the using the same fabrics as in Chapter 3.

2.3.1 Fabrics

The selection of fabrics changed during the course of this study. The fabrics initially selected were experimental fabrics used in the original research in support of the development of Tier 1 PPS. Subsequent to the research in Chapter 3 being conducted, the fabrics were changed to represent the fabrics used in the Tier 1 PPS, the EP-UBACS and a fabric typically used in combat body armour. The fabrics investigated in Chapter 3 were:

- single jersey knitted silk
- hydro entangled ultra-high molecular weight polyethylene felt
- para-aramid felt
- woven para-aramid fabric (loom state)

The fabrics investigated in Chapters 4, 5, 6 and 7 were:

- double jersey interlock knitted silk
- hydro entangled ultra-high molecular weight polyethylene felt
- woven para-aramid fabric scoured

The effect of laundering on the para-aramid fibres in the para-aramid felt was identical to the woven para-aramid. The change in dimensional properties due to

laundering of the para-aramid felt and UHMWPE felt were identical. It was therefore decided to discontinue the investigation into the para-aramid felt after Chapter 3.

The single jersey knit silk used in Chapter 3 was changed to a double jersey interlock knitted silk as this was selected for the Tier 1 PPS due to its better dimensional stability (Taylor, 2007).

The woven para-aramid was changed after Chapter 3 from loom state to scoured to eliminate the effect of removing the size from the fabric from the comparison of the ballistic performance, as this has been shown to affect ballistic performance (Morrison et al., 1978).

The hydro entangled ultra-high molecular weight polyethylene felt was procured from a different supplier after Chapter 3, due to the availability of fabric from the manufacturer of the EP-UBACS. This was identified as a potential cause for differences in results and performance of the fabric between the chapters.

2.3.2 Laundering regimes

Chapter 3 investigated the effect of a typical domestic laundering regime that is stipulated for military clothing. This laundering regime was expanded after Chapter 3 to include a higher temperature wash more typical of laundering by the Armed Forces on operations and laundering regimes that had been reported to have been used in some forward operating bases in Afghanistan (Lewis, 2010). The washing

machine and tumble dryer used in Chapters 4 and 5 varied from those used in Chapter 3 due to the unavailability of the original laundry facility. The changes were not considered to have affected the results of the study and demonstrated that the effects observed were not limited to any specific design of washing machine / tumble dryer. The following laundering regimes were used in the course of this study:

- Laundered at 40 °C in a domestic washing machine and tumble dried in a domestic tumble dryer.
- Laundered at 90 °C in a domestic washing machine and tumble dried in a domestic tumble dryer.
- Washing with a Cement mixer, to replicate laundering observed in some frontline bases in Afghanistan.

2.4 References

Lewis, E. 2010. Washing of Combat Clothing. Request for Information Serial

H13RF007. Deputy Scientific Advisor, Head Quarters - Task Force Helmand.

Morrison, C. E. & Bowyer, W. H. 1978. Factors affecting ballistic impact resistance of

Kevlar 49 reinforced composites. R762/1/August 1978. Fulmer Research

Institute Limited.

Randall, A. 19 March 2013. *RE: Review of fabrics and laundering regimes for*

degradation studies. Meeting at DE&S Abbey Wood with HELLIKER, M.

Taylor, M. A. 2007. *Technology of Textile Properties*, Forbes Publications.

3 EFFECT OF DOMESTIC LAUNDERING ON THE FRAGMENT PROTECTIVE PERFORMANCE OF FABRICS USED IN PERSONAL PROTECTION

3.1 General

The effect of laundering on the fragment protective performance of fabrics used in fragment protective clothing on operations in Afghanistan was of interest. In-service Tier 1 PPS was introduced into service as an Urgent Operational Requirement and as such, its long term³ performance had not been evaluated. In order to assess the effect of limited laundering on the fabrics under investigation, fabric samples were laundered (representative of a 6 month operational tour) and then tested in a ballistics trial. Other material properties were also assessed, such as dimensional stability. The work presented was used by the UK MOD to support the business case for maintaining the silk as the ballistic protective element of the Tier 1 PPS.

Three other candidate fabrics were also investigated in this study to identify suitable alternatives should the silk fail to provide a suitably robust solution for the equivalent of a six month tour. The work identified that the UHMWPE felt would be a potentially suitable solution for some clothing applications. The fabric was therefore used to provide the ballistic protective element of the Enhance Protection Under Body Armour Combat Shirt (EP-UBACS). The chapter in question is in the format of the submitted article published in the Textile Research Journal and is presented in its

³ Long term being beyond the garments performance when issued to the Armed Forces personnel

entirety. Therefore information in the introduction, aims and subsequent chapters may be duplicated in this chapter.

The following chapter is based on the paper published in the Textile Research Journal; **Helliker**, M., Carr, D.J., Lankester, C., Fenton, L., Girvan, L. & Horsfall, I. 2014. Effect of domestic laundering on the fragment protective performance of fabrics used in personal protection. Textile Research Journal 84: 1298-1306.

Effect of domestic laundering on the fragment protective performance of fabrics used in personal protection

Mark Helliker^{1,2}, Debra Carr², Claire Lankester², Leigh Fenton² Ian Horsfall² and Liz Girvan³

¹ Physical Sciences Group, Dstl, Porton Down, Salisbury, Wiltshire, SP4 0JQ, UK.

² Impact and Armour Group, Centre for Defence Engineering, Cranfield University, Defence Academy of the United Kingdom, Shrivenham, SN6 8LA, UK.

³ Otago Centre for Electron Microscopy, University of Otago, Dunedin, New Zealand

I, Mark Helliker, hereby state that the work presented in the article presented in Chapter 3 is my own, and the co-authors only provided me with guidance on interpreting the research, technical assistance in conduction of the experiments and provided editorial input on the manuscript.

3.2 Introduction

The incorporation of hierarchical fragment protection into combat uniforms (as opposed to body armour) has recently been discussed in the open literature (Sakaguchi et al., 2009, Lewis et al., 2013). This work suggested the use of one- or two-layers of fragment protective fabrics incorporated into combat uniforms to provide a degree of protection to the extremities. UK Armed Forces now wear items of clothing that incorporate such levels of fragment protection (e.g. Tier 1 PPS, Figure 3-1 a) and other items of clothing are being developed (e.g. EP-UBACS, Figure 3-1 b). Other nations now use similar items of clothing. Ballistic protective clothing in use with the British Armed Forces has used knitted silk to provide the base level of protection (Lewis et al., 2013). Other materials have been of interest for this application and include UHMWPE felt, para-aramid felt and woven para-aramids.



Figure 3-1 a) Tier 1 PPS b) EP-UBACS Concept Demonstrator

The long term robustness of such garments is critical. Inter-layer wear with reference to fabrics typically used in police and military body armours has been discussed (Forster et al., 2009, Pinto et al., 2011). The effect of moisture on typical ballistic protective fabrics has been previously investigated (Bazhenov et al., 1999, Bazhenov et al., 2012). Some of this work identified that removal of lubricants from the weaving process may result in improved performance, as the friction between yarns will increase (Morrison, 1984, Bazhenov, 1997, Bhatnagar, 2006). Although military body armour protective packs are rarely laundered, combat clothing (including Tier 1 and UBACS) is routinely laundered. Laundering is one of the most aggressive degradative agents a fabric is exposed to during use resulting in changes in physical and mechanical properties (e.g. (Slater, 1991, Gore et al., 2006, Van Amber et al., 2010)). Therefore, whether laundering affects fragment protective clothing is of interest.

The aim of this work was to determine the effect of multiple domestic washing and drying cycles on the fragment protective properties of packs representative of fragment protective clothing. Dimensional stability, mass and thickness of specimens were also considered with reference to possible shrinkage of clothing.

3.3 Materials and methods

The effect of laundering on four fabrics was assessed. Specimens (400 mm x 400 mm) were manufactured using two layers of fabric encased in a disruptive pattern

polyester-cotton fabric (70% polyester 30% cotton; twill 3/1; 12 x 12 yarns / 10 mm, 175 g/m²). Specimens were quilted using stitch type 301 every 100 mm as shown in Figure 3-2 (British Standards Institute, 1991). Each of the fragment protective fabrics was provided loom state. The four fabrics under investigation were:

- single jersey knit silk, 130 g/m²
- hydro-entangled ultra-high molecular weight polyethylene (UHMWPE) felt, 200 g/m²
- para-aramid felt, 200 g/m²
- woven para-aramid, 156 g/m²



Figure 3-2 Typical specimen mounted for ballistic testing

Four sets of specimens were prepared for each fabric, set one was not-laundered. The remaining specimens were washed with laundry detergent⁴ for either 9, 18 or 27 cycles using a Bosch Logixx 8 VarioPerfect WAS32460GB washing machine set at a

⁴ Detergent Laundry (Non Bio, Low Foam) NATO Stock Number: 7930992251626

mixed load programme and 40 °C, 45min wash with spin speed of 800 rpm. Specimens were then dried after each washing cycle using a Bosch Exxcel Condenser WTE86308GB tumble drier (cupboard dry cycle, approximately 90 minutes). These conditions were chosen to represent typical in-use laundering by service personnel and are recommended on the garment's care label. Personnel are issued with multiple sets of items such as Tier 1 PPS for an operational tour, and 27 laundering cycles approximates the number of times items would be laundered on operations before replacement.

After laundering, specimens were conditioned at for a minimum of 24 hours according to BS EN ISO 139: 2005 (20 °C ± 2 °C; 65 %R.H. ± 4 %R.H.) (British Standards Institute, 2005). The effect of laundering on 0.24 g (4 grain) chisel nosed fragment simulating projectile (FSP) (Stores and Clothing Research and Development Establishment, 1993) V_{50} ⁵ data was determined. A number 3 Enfield proof mount fitted with an L85 (SA80) barrel was used to fire FSPs which were placed in a polymeric sabot and fired by adjusting the mass of Vihtavuori N330 propellant used in hand-loaded 5.56 x 45 mm L15A2 cartridge cases (manufactured by Radway Green between 1998 and 2001).

All specimens were mounted on the UK MoD behind armour blunt trauma (BABT) rig described by Cannon (Cannon, 2001). This was in order to provide a support to the

⁵ The V_{50} is the velocity at which there is a statistical probability of 50% of a given projectiles completely perforating the target.

samples similar to “as worn”, as this may affect the performance of the fabrics. Due to the low energy levels involved in these impacts, no assessment of the risk of sustaining BABT was conducted in this work due to the relatively low energies of the projectile. Specimens were placed approximately 5 m from the end of the muzzle. A Doppler radar system was used to measure the velocity of the projectiles (see Figure 3-3 for a diagram of the range setup). FSPs were fired at each specimen in such a manner that no impact occurred within 50 mm of the specimen edge; 50 mm from a previous impact; and avoiding previously impacted warp, wale or 'x' and weft, course and 'y' yarns or orientations. Whether or not the FSP perforated the specimen was noted. During the tests the temperature and relative humidity were recorded (mean temperature: 20.0 °C, SD 1.1 °C; mean relative humidity: 40.7%, SD 5.2%), along with the charge mass and the velocity of the projectile.

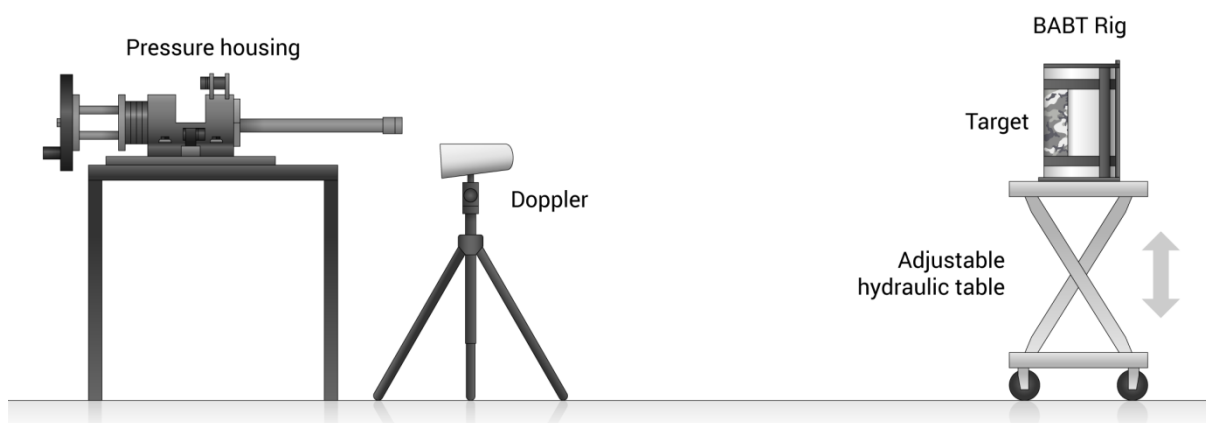

Figure 3-3 Range set-up used in the ballistic trials (Copyright 2017, Cranfield University Media)

Estimated 0.24 g FSP V_{50} data were calculated using the Dstl Critical Perforation Analysis (CPA) tool based on the R statistical software package (R Core Team, 2012). The CPA tool calculates the V_{50} based on the Probit statistical method (Bliss, 1934, Fisher, 1935, Finney, 1971, McCullagh et al., 1989, Firth, 1993). The tool used the bias reduction estimation procedure for the standard generalized linear model introduced by Firth (1993). This is a method that adjusted the estimation process to ensure that the standard errors produced are finite and lead to meaningful confidence intervals and inference using regression models with binary outcome data. Using the CPA tool, the standard error and the 95th percentile confidence limits of each V_{50} were calculated. Calculating the confidence limits provides an indication of the variability in the ballistic performance of each of the specimens. Between 35 and 39 shots were used in each calculation of the V_{50} and the confidence limits.

A Probit regression model was fitted to the ballistic performance data (Finney, 1971). This model was used to compare the number of laundering cycles to determine if there was any significant difference in the V_{50} for each condition. The differences were assessed using a Wald test (Draper et al., 1998) on the model parameters. The non-laundered data was the baseline group.

Damage to the fabric specimens was investigated using a JEOL 6700F field emission scanning electron microscope (FESEM; LEI detector, 3 kV, 8-17 mm working distance); specimens were mounted on aluminium stubs with double sided

carbon tape and sputter coated with gold palladium using Emitech K575X Peltier-cooled high resolution sputter coater. The typical images were taken from areas of the samples chosen to be more than 100mm from any edge and not in an area disrupted by quilting or ballistic impact.

Specimen dimensional change was measured using BS EN 5077:2008 (British Standards Institute, 2008) and change in thickness was measured using a Mitutoyo dial-thickness gauge in accordance with BS EN ISO 5084:1996 (British Standards Institute, 1997).

3.4 Results and discussion

The effect of laundering on ballistic performance is summarised in Table 3-1. Data for laundered specimens are normalised against results for non-laundered specimens⁶.

⁶ Actual performance data cannot be quoted as these relate to the protection afforded by in-service equipment and is classified information.

Table 3-1 Summary data of relative ballistic performance compared to baseline

Washes	Silk			UHMWPE			Felted para-aramid			Woven para-aramid		
	V ₅₀ (%)	SE (%)	p value	V ₅₀ (%)	SE (%)	p value	V ₅₀ (%)	SE (%)	p value	V ₅₀ (%)	SE (%)	p value
Baseline	100.0	2.8	-	100.0	2.5	-	100.0	2.8	-	100.0	2.7	-
9 Cycles	103.9	1.4	> 0.05 Baseline	102.6	4.8	> 0.05 Baseline	116.5	2.3	< 0.01 Baseline	114.3	2.5	< 0.01 Baseline
18 Cycles	102.4	3.1	> 0.05 Baseline > 0.05 9 Cycles	99.7	2.7	> 0.05 Baseline > 0.05 9 Cycles	112.2	1.9	< 0.01 Baseline > 0.05 9 Cycles	119.9	3.5	< 0.01 Baseline > 0.05 9 Cycles
27 Cycles	102.0	2.7	> 0.05 Baseline > 0.05 9 Cycles > 0.05 18 Cycles	100.6	2.4	> 0.05 Baseline > 0.05 9 Cycles > 0.05 18 Cycles	115.8	2.7	< 0.05 Baseline > 0.05 9 Cycles > 0.05 18 Cycles	113.0	4.1	< 0.01 Baseline > 0.05 9 Cycles > 0.05 18 Cycles

There was no difference in the ballistic protective performance of the silk and UHMWPE specimens between non-laundered and 9 cycle laundered, non-laundered and 18 cycle laundered, or non-laundered and 27 cycle laundered ($p > 0.05$).

There was strong evidence of a difference in performance of the felted para-aramid and woven para-aramid specimens between 0 and 9 laundering cycles ($p < 0.01$).

There was no evidence of a difference between 9 laundering cycles and 18 laundering cycles, or 18 laundering cycles and 27 laundering cycles for these two fabrics ($p > 0.05$).

All fabrics showed a statistically significant change in physical properties due to laundering ($p < 0.01$) (

Table 3-2 to Table 3-5).

The silk shrank in both the wale and course directions. The shrinkage in the course direction was greater than in the wale direction (residual mean wale = 97.9 %; residual mean course = 96.2 %). The UHMWPE and felted para-aramid shrank uniformly in both the “x” and “y” directions (residual mean 94 % and 95.5 %). The woven para-aramid shrank more in the warp direction than in the weft direction (residual mean warp = 96.8 %; residual mean weft = 98.5 %). As expected, the two felted fabrics shrank more after laundering than the silk or the woven para-aramid (Taylor, 2007). The reductions in the two dimensions were matched by a corresponding increase in the thickness of the samples. The increase in thickness did not correspond to the change in ballistic protective performance. However, the increased thickness of the samples would be expected to increase the thermal resistance of the garments (Wilson et al., 2002) and resulted in changes in its appearance (Slater, 1991). In comparison, there was no significant change in the mass of the specimens, indicating no loss of fibre due to laundering. Ballistic protective clothing that incorporates felts would be more severely affected by laundering, than the knitted or woven fabrics examined in this study (Taylor, 2007).

Table 3-2 Changes in physical properties for silk

	Course (%)	SE (%)	p value (F _{3,20} = 19.0)	Wale (%)	SE (%)	p value (F _{3,20} = 2.8)	Thickness (%)	SE (%)	p value (F _{3,20} = 10.5)
Baseline	100.0	0.2	-	100.0	0.4	-	100.0	0.9	-
9 Cycles	95.6	0.2	> 0.05 Baseline	97.4	0.8	NS	114.1	0.2	< 0.01 Baseline
18 Cycles	95.1	0.1	> 0.05 Baseline > 0.05 9 Cycles	97.6	1.0	NS	122.9	4.7	< 0.05 Baseline > 0.05 9 Cycles
27 Cycles	97.9	1.0	< 0.05 Baseline < 0.05 9 Cycles < 0.01 18 Cycles	98.6	0.6	NS	116.1	0.7	< 0.01 Baseline > 0.05 9 Cycles > 0.05 18 Cycles

Table 3-3 Changes in physical properties for UHMWPE

	"X" (%)	SE (%)	p value (F _{3,20} = 155.3)	"Y" (%)	SE (%)	p value (F _{3,20} = 173.7)	Thickness (%)	SE (%)	p value (F _{3,20} = 13.7)
Baseline	100.0	0.2	-	100.0	0.1	-	100.0	3.1	-
9 Cycles	94.5	0.3	< 0.01 Baseline	96.3	0.2	< 0.01 Baseline	140.7	5.6	< 0.01 Baseline
18 Cycles	92.4	0.5	< 0.01 Baseline < 0.01 9 Cycles	93.3	0.4	< 0.01 Baseline < 0.01 9 Cycles	164.8	3.4	< 0.05 Baseline > 0.05 9 Cycles
27 Cycles	90.9	0.4	< 0.01 Baseline < 0.01 9 Cycles < 0.05 18 Cycles	90.9	0.4	< 0.01 Baseline < 0.01 9 Cycles < 0.01 18 Cycles	164.5	7.9	< 0.01 Baseline > 0.05 9 Cycles > 0.05 18 Cycles

Table 3-4 Changes in physical properties for felted para-aramid

	"X" (%)	SE (%)	p value (F _{3,20} = 53.3)	"Y" (%)	SE (%)	p value (F _{3,20} = 38.8)	Thickness (%)	SE (%)	p value (F _{3,20} = 5.7)
Baseline	100.0	0.4	-	100.0	0.1	-	100.0	1.6	-
9 Cycles	96.8	0.6	< 0.01 Baseline	97.5	0.4	< 0.01 Baseline	119.2	4.5	> 0.05 Baseline
18 Cycles	93.9	0.3	< 0.01 Baseline < 0.01 9 Cycles	96.4	0.4	< 0.01 Baseline > 0.05 9 Cycles	135.1	8.4	< 0.01 Baseline > 0.05 9 Cycles
27 Cycles	93.8	0.3	< 0.01 Baseline < 0.01 9 Cycles > 0.05 18 Cycles	95.6	0.3	< 0.01 Baseline < 0.01 9 Cycles > 0.05 18 Cycles	128.2	1.1	< 0.05 Baseline > 0.05 9 Cycles > 0.05 18 Cycles

Table 3-5 Changes in physical properties for woven para-aramid

	Warp (%)	SE (%)	p value (F _{3,20} = 220.0)	Weft(%)	SE (%)	p value (F _{3,20} = 19.1)	Thickness (%)	SE (%)	p value (F _{3,20} = 6.6)
Baseline	100.0	0.1	-	100.0	0.2	-	100.0	2.6	-
9 Cycles	97.3	0.1	< 0.01 Baseline	98.8	0.1	< 0.01 Baseline	105.6	1.6	> 0.05 Baseline
18 Cycles	96.7	0.1	< 0.01 Baseline < 0.01 9 Cycles	98.6	0.2	< 0.01 Baseline > 0.05 9 Cycles	107.2	0.9	< 0.05 Baseline > 0.05 9 Cycles
27 Cycles	96.4	0.0	< 0.01 Baseline < 0.01 9 Cycles > 0.05 18 Cycles	98.2	0.2	< 0.01 Baseline > 0.05 9 Cycles > 0.05 18 Cycles	110.1	0.7	> 0.05 Baseline > 0.05 9 Cycles < 0.01 18 Cycles

Typical examples of the images obtained using FESEM are given in Figure 3-4 to Figure 3-7. The silk and para-aramid fibres were degraded through laundering by surface peeling of the fibres. This type of damage to has been previously reported

for both silk and para-aramid fibres and may be indicative of a loss in tenacity of yarns and fabrics (Van Amber et al., 2010, Pinto et al., 2011). The peeling of the surface of the fibres might increase the friction between yarns. There is evidence that increasing the friction between yarns can affect the ballistic protective performance of fabrics (Duan et al., 2005); this might account for the increase in ballistic protective performance of the two para-aramid fabrics after laundering. Another possible contribution to the change in fabric ballistic performance may be due to the lubricants used in the manufacturing process having been removed during laundering. These lubricants are added to the yarns in the weaving / knitting process to improve the quality of the fabric and reduce damage to the fibres. It is known that fabric that has been 'scoured' has shown improved ballistic performance to identical fabric in the loom state (Bazhenov, 1997, Bhatnagar, 2006, Rao et al., 2009). The UHMWPE fibres exhibited a different degradative mechanism via localised swelling and longitudinal splitting. Such degradation does not appear to have been previously reported. This damage to the fibres does not appear to have resulted in any change in ballistic protective performance.

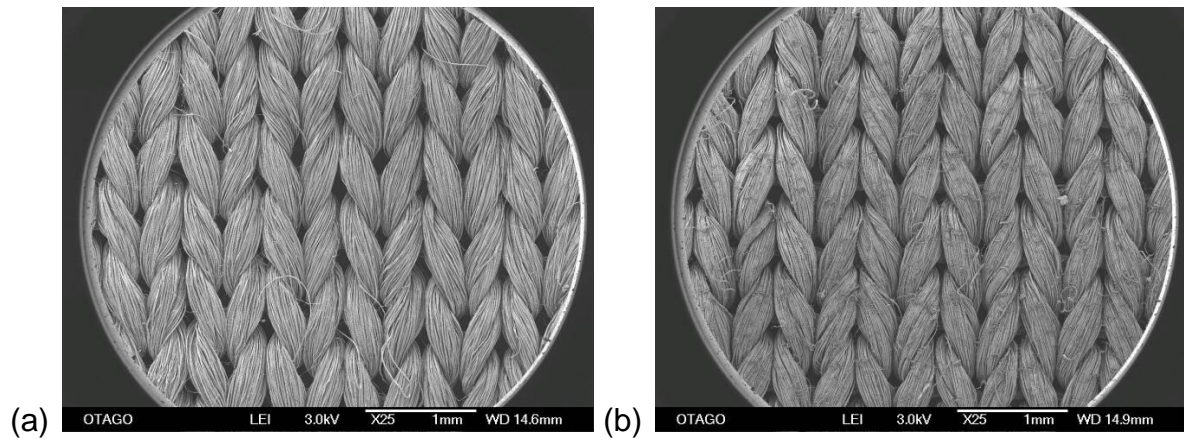

0 Cycles

27 Cycles

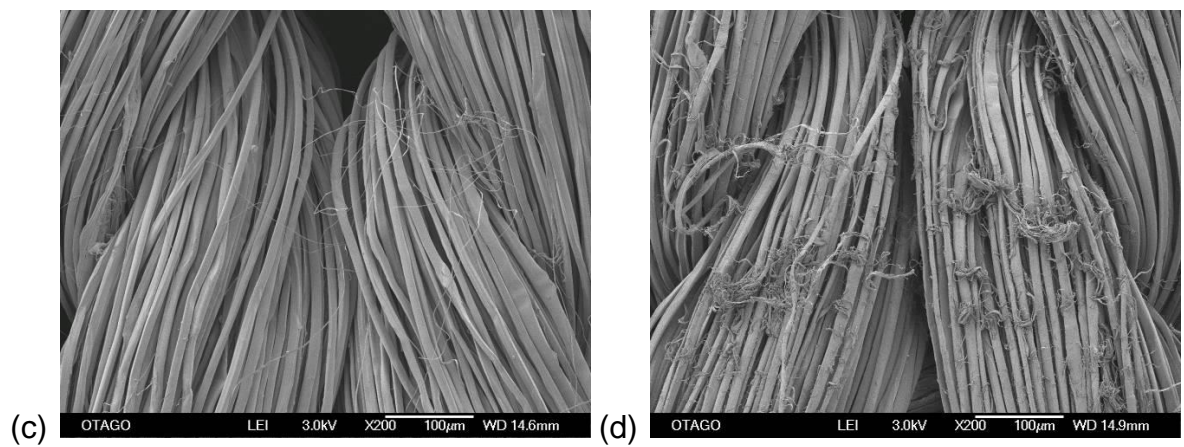

0 Cycles

27 Cycles

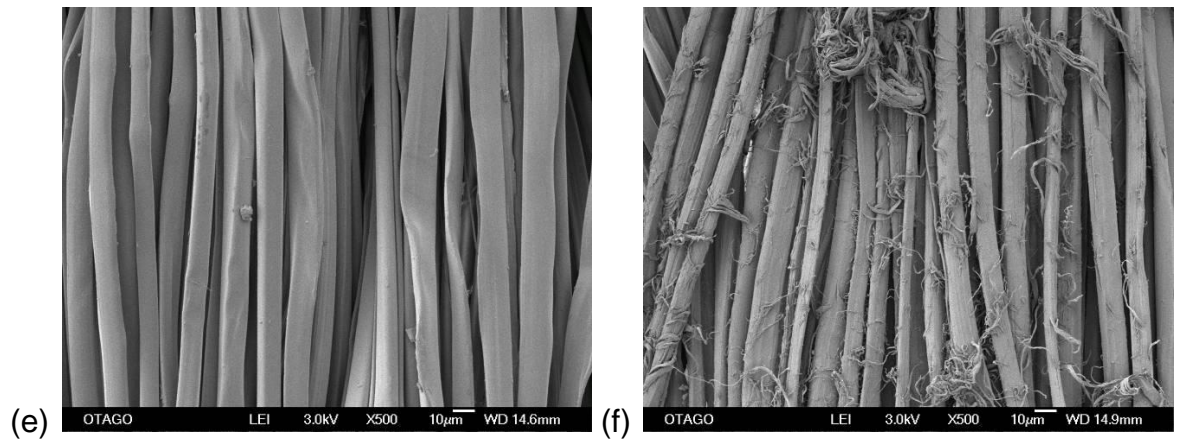

0 Cycles

27 Cycles

Figure 3-4 FESEM images of silk before and after laundering

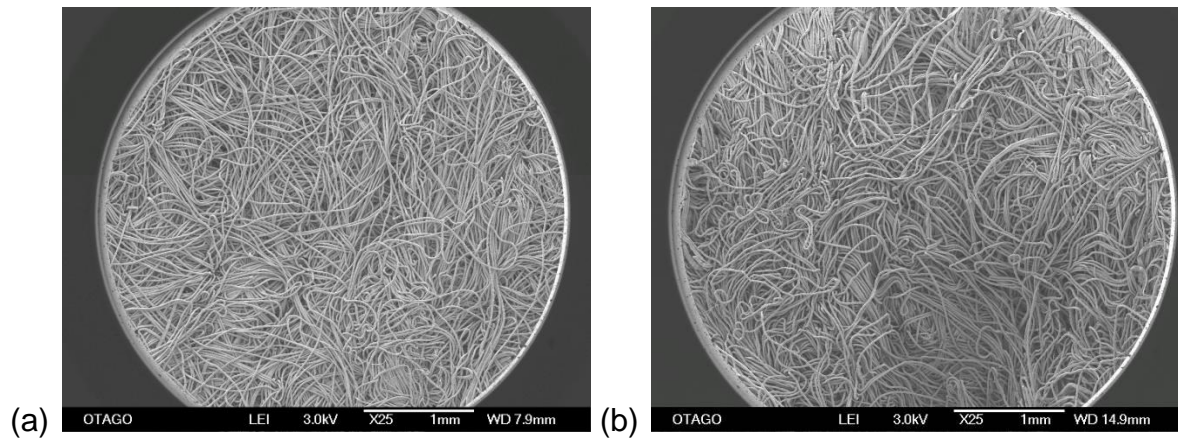

0 Cycles

27 Cycles

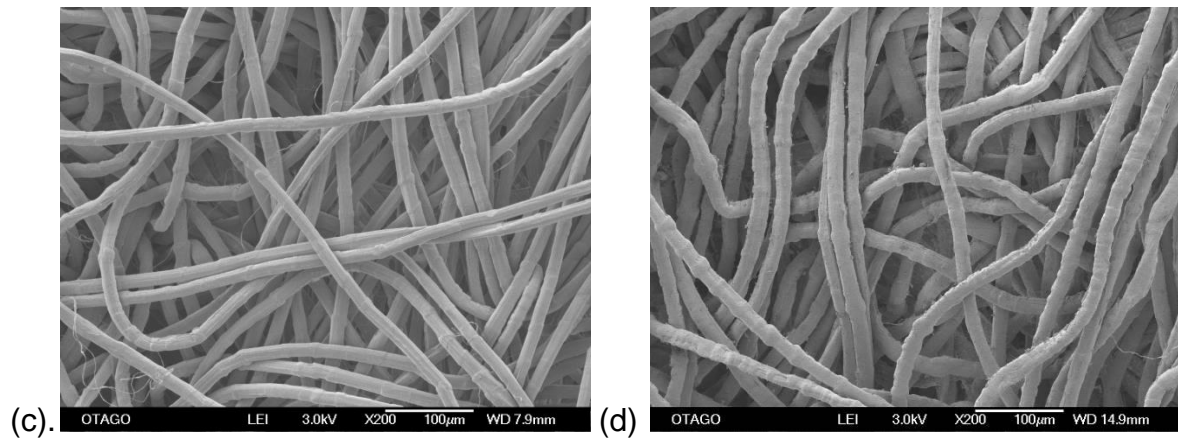

0 Cycles

27 Cycles

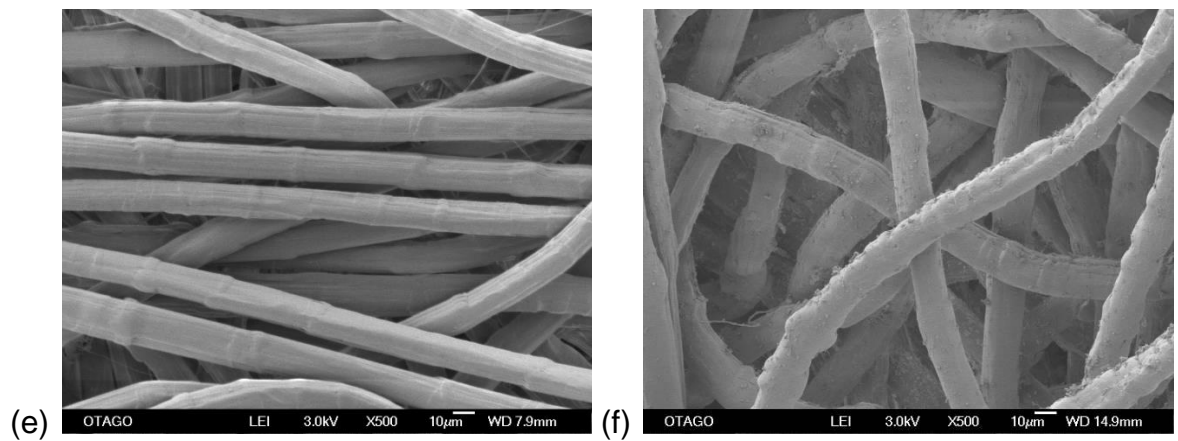

0 Cycles

27 Cycles

Figure 3-5 FESEM images of UHMWPE before and after laundering

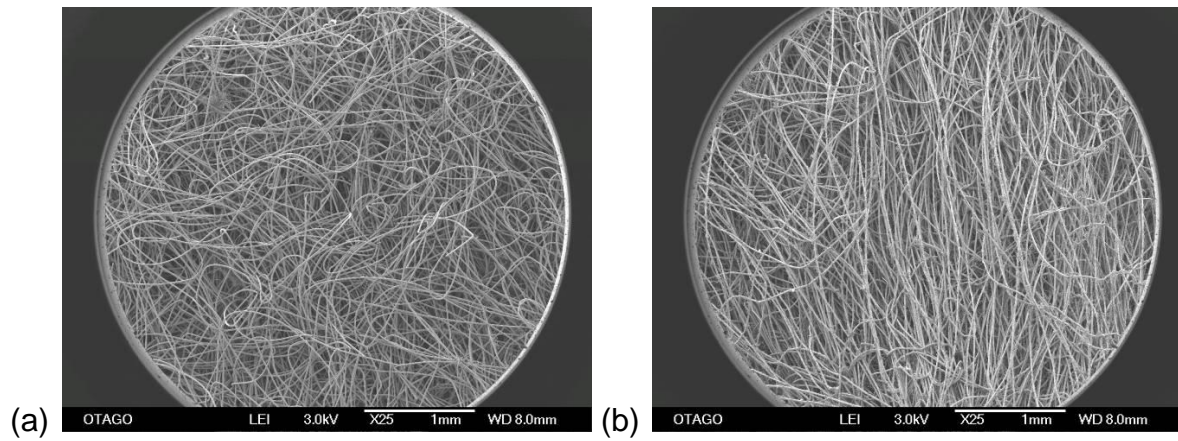

0 Cycles

27 Cycles

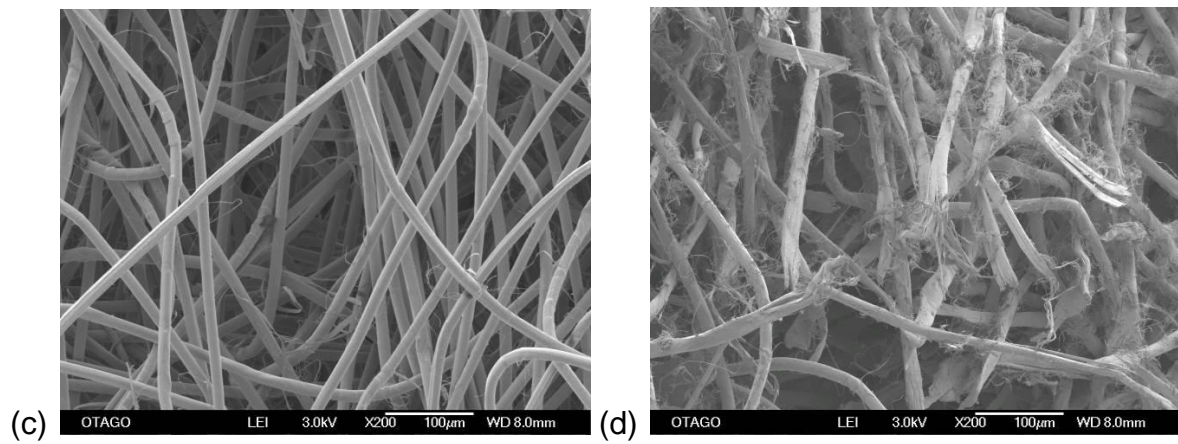

0 Cycles

27 Cycles

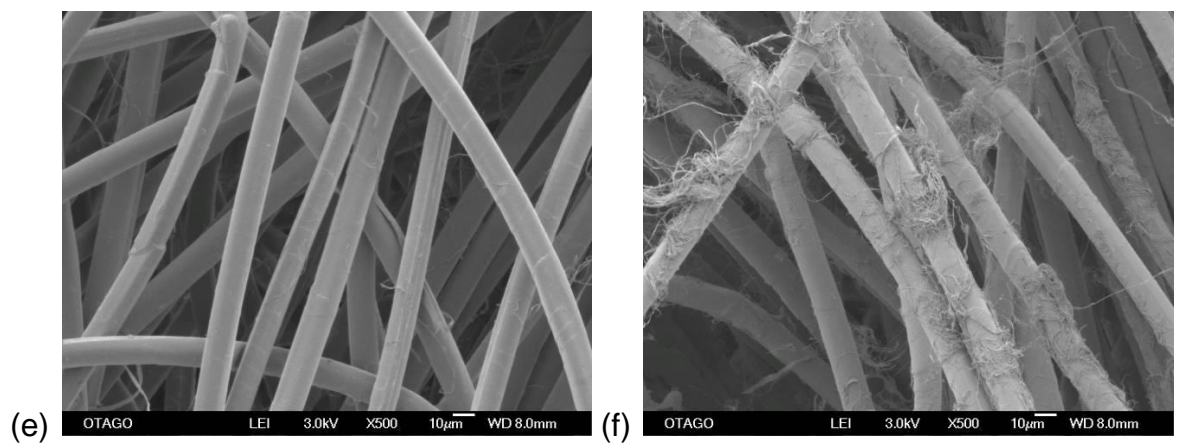

0 Cycles

27 Cycles

Figure 3-6 FESEM images of felted para-aramid before and after laundering

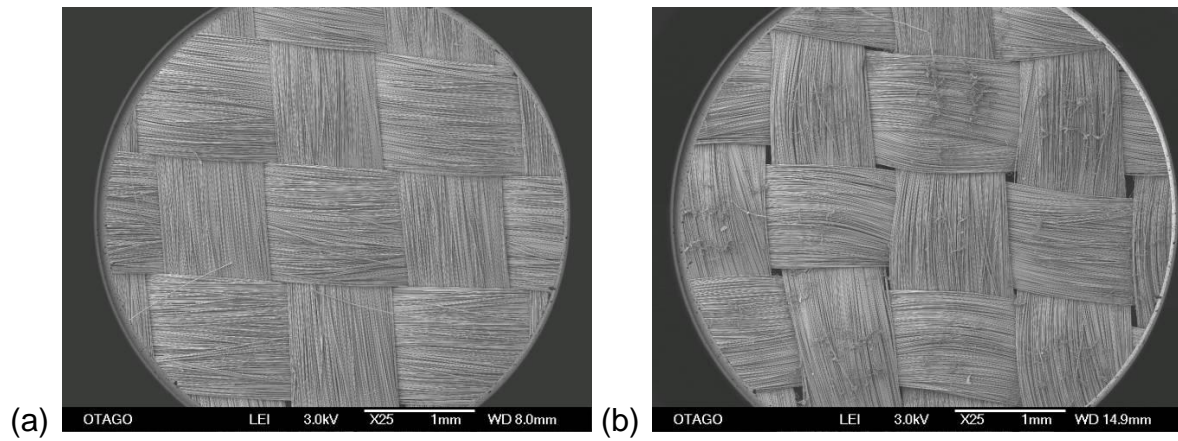

0 Cycles

27 Cycles

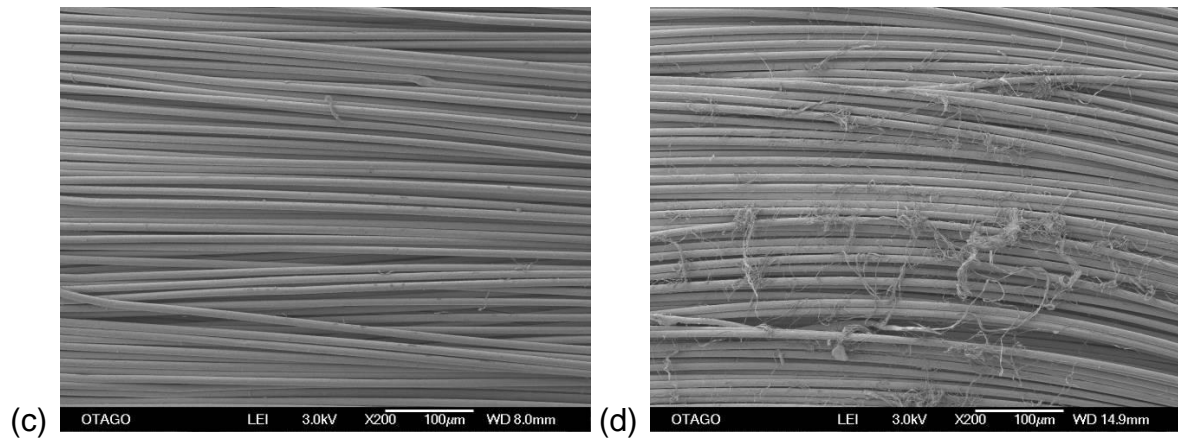

0 Cycles

27 Cycles

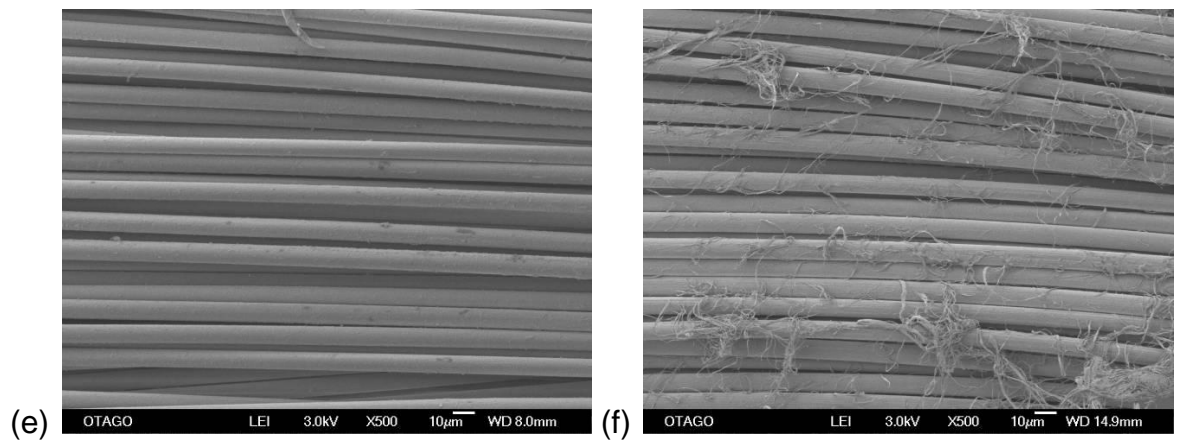

0 Cycles

27 Cycles

Figure 3-7 FESEM images of woven para-aramid before and after laundering

3.5 Conclusions

The data collected suggested that the ballistic protective performance of silk and UHMWPE measured using 0.24 g FSPs was not affected by up to 27 laundering cycles. The felted para-aramid and the woven para-aramid showed improved performance against the 0.24 g FSP after 9 laundering cycles. It is not known at this time whether laundering at higher temperatures would affect these results. Whether this increase in performance is due to the removal of the lubricants used in knitting/weaving or the surface peeling of the fibres and hence an increase in friction between fibres/yarns is uncertain (Duan et al., 2005, Rao et al., 2009).

Changes in the dimensions for the felted para-aramid and the UHMWPE resulted in a significant decrease in the surface area of the fabric panels. The silk and woven para-aramid showed only slight decrease in fabric surface area. The respective increases in thickness followed the same trend as changes in dimensions. This information is important not only because the dimensional change on laundering might contribute towards the changes in ballistic performance identified, but also due to changes in appearance, comfort for the wearer and thermal resistance in combat clothing.

3.6 Acknowledgments

The authors acknowledge the assistance of Linda Jenkins of DSTL for the conditioning of the specimens, Mr Adrian Randall (DE&S) for information regarding the fabrics used in current clothing and Dr Eluned Lewis for information regarding the laundering practices on operations in Afghanistan.

3.7 References

- Bazhenov, S. L. 1997. Dissipation of energy by bulletproof aramid fabric. *Journal of Material Science*, 32:4167-4173.
- Bazhenov, S. L. & Goncharuk, G. P. 2012. A study of yarn friction in aramid fabrics. *Polymer Science Series A*, 54(10):803-808.
- Bazhenov, S. L., Rozhkov, A. N., Kovalev, P. I., et al. 1999. Ballistic Tests of Aramid Armos and SVM Fabric Laminates. *Proceedings of the Novel Materials Workshop*. Cavendish Laboratory, Cambridge, UK: DERA.
- Bhatnagar, A. 2006. *Lightweight ballistic composites - Military and law-enforcement application*, Cambridge, England, Woodhead Publishing in materials.
- Bliss, C. I. 1934. The method of probits. *Science*, 79(2037):38-39.
- British Standards Institute. BS 3870-1:1991 Stitches and seams part 1: classification and terminology of stitch types (ISO 4915:1991). 1991. BS 3870-1:1991.
- British Standards Institute. BS EN ISO 5084:1997 Textiles - Determination of thickness of textiles and textile products 1997. BS EN ISO 5084:1997.
- British Standards Institute. BS EN ISO 139:2005 Textiles - Standard atmospheres for conditioning and testing +A1:2011. 2005. BS EN ISO 139:2005.
- British Standards Institute. BS EN ISO 5077:2008 Textiles - Determination of dimensional change in washing and drying. 2008. BS EN ISO 5077:2008.
- Cannon, L. 2001. Behind Armour Blunt Trauma - an emerging problem. *Journal of the Royal Army Medical Corps*, 147:87-96.

- Draper, N. R. & Smith, H. 1998. Applied Regression Analysis, New York, John Wiley & Sons Inc.
- Duan, Y., Keefe, M., Wetzel, E. D., et al. 2005. Effects of friction on the ballistic performance of a high-strength fabric structure. WIT Transactions on Engineering Sciences, 49:219-229.
- Finney, D. J. 1971. Probit Analysis, Cambridge, Cambridge University Press.
- Firth, D. 1993. Bias reduction of maximum likelihood estimates. Biometrika, 80:27-38.
- Fisher, R. A. 1935. Appendix to Bliss (1935). Annals of Applied Biology, 22(4):164-165.
- Forster, A. L., Messin, G. H. R. & Pintus, P. 2009. Development of Soft Armor Conditioning Protocols for NIJ Standard-0101.06: Analytical Results. National Institute of Standards and Technology.
- Gore, S. E., Laing, R. M., Wilson, C. A., et al. 2006. Standardizing a pre-treatment cleaning procedure and effects of application on apparel fabrics. Textile Research Journal, 76(6):455-464.
- Lewis, E. A., Pigott, M. A., Randall, A., et al. 2013. The development and introduction of ballistic protection of the external genitalia and perineum. Journal of the Royal Army Medical Corps, 159(Supp I):i15-i17.
- McCullagh, P. & Nelder, J. A. 1989. Generalized Linear Models, London, Chapman and Hall.

- Morrison, C. E. 1984. The mechanical response of an aramid textile yarn to ballistic impact. PhD, University of Surrey.
- Pinto, R., Carr, D. J., Helliker, M., et al. 2011. Degradation of military body armour due to wear: laboratory testing. *Textile Research Journal*, 82(11):1157-1163.
- R Core Team 2012. R: A language and environment for statistical computing, Vienna, R Foundation for Statistical Computing.
- Rao, M. P., Duan, Y., Keefe, M., et al. 2009. Modeling the effects of yarn material properties and friction on the ballistic impact of a plain-weave fabric. *Composite Structures*, 89(4):556-566.
- Sakaguchi, S. M., Carr, D. J., Horsfall, I., et al. 2009. Protecting the extremities of military personnel: fragment protective performance of one- and two-layer ensembles. *Textile Research Journal*, 82(12):1295-1303.
- Slater, K. 1991. *Textile degradation*, The Textile Institute.
- Stores and Clothing Research and Development Establishment. 1993. *Fragment Simulating Projectile*. A3/6723/3. Ministry of Defence.
- Taylor, M. A. 2007. *Technology of Textile Properties*, Forbes Publications.
- Van Amber, R. R., Niven, B. E. & Wilson, C. A. 2010. Effects of Laundering and Water Temperature on the Properties of Silk and Silk-blend Knitted Fabrics. *Textile Research Journal*, 80(15):1557-1568.

Wilson, C. A., Laing, R. M. & Carr, D. J. 2002. Air and Air Spaces - the Invisible Addition to Thermal resistance. *Journal of the Human-Environmental Systems*, 5(2):69-77.

4 EFFECT OF WASH TEMPERATURE AND DURATION IN DOMESTIC LAUNDERING IN COMPARISON WITH AND IMPROVISED WASHING METHOD ON THE FRAGMENT PROTECTIVE PERFORMANCE OF FABRICS USED IN PERSONAL PROTECTION

4.1 General

From the research presented in Chapter 3 it was shown that laundering at 40 °C did not adversely affect the ballistic protective performance of the selected fabrics of interest for fragment protective clothing. In the case of the para-aramid fabrics, the performance of the fabric was improved through laundering.

Chapter 4 investigated:

- whether increased wash temperature would alter the change in performance of three of the selected fabrics seen previously. The basis of the increase in the wash temperature was to replicate more closely the laundering regimes that were used on operations in Afghanistan by British Forces.
- whether laundering for extended periods which represented the equivalent of nine months on operations affected the performance of three of the selected fabrics. This work was conducted in support of an urgent request for information to ascertain the consequences of extended the last operational tour of British Forces in Afghanistan to nine months as opposed to the usual six. The work presented in this chapter informed the replacement policy for the fragment protective clothing issued at the time, and whether a logistic resupply was required mid-tour to replace the PPS and the EP-UBACS. The analysis of the fabrics included ballistic protective performance, ball burst

strength and dimensional change. The results of this work were used as supporting evidence to extend the in-theatre life of these items of fragment protective clothing, saving the UK Government in excess of £1.4M⁷.

- the effect of laundering using a cement mixer, representative of laundering conducting in some forward operating bases in Afghanistan. This work was initiated in response to a request for information by the MOD DE&S on the effect of alternative methods of laundering clothing and determine whether the effects of laundering identified previously was specific to the equipment used.

The initial work conducted in Chapter 3 was conducted during the development of the Tier 1 PPS and the EP-UBACS. After this initial work the fabrics selected for inclusion in these garments were changed from the original fabrics used in this study. As a result there were differences in the fabrics used in Chapter 4 and Chapter 5 in comparison with the original work in Chapter 3. In addition, the laundering regimes were more varied in order to be more representative of those that these garments would be exposed to. The washing machine and the tumble dryer varied from Chapter 3 due to lack of availability of the original laundry facility used for the previous conditioning. As the same trends were observed in both Chapter 3 and Chapter 4, it was considered that the change of washing machine and tumble dryer had not altered the trends observed.

⁷ This estimate was based on an approximate cost for each item of Tier 1 PPS and EP-UBACS, the number of items issued to each individual and the number of British Forces deployed to that operational theatre at that time. It does not include the cost of a resupply or other logistic considerations.

In Chapter 4 the method of assessing the change in ballistic performance was altered, in as much as the targets were no longer mounted on the UK MOD BAPT Rig. This was in order to allow residual velocity of the FSP to be measured. As a result these measurements failed to provide any form of insight and have not been included in this thesis.

The analysis of the fabrics was expanded to include ball burst strength, and Fourier transform infra-red (FTIR) spectroscopy analysis in the near infra-red and mid infra-red parts of the spectrum.

Note that this chapter is in the format of a submitted article and presented in its entirety. Therefore information in the introduction may be duplicated in this chapter.

Effect of wash temperature and duration in domestic laundering in comparison with and improvised washing method on the fragment protective performance of fabrics used in personal protection

Mark Helliker¹, Debra Carr¹, Claire Lankester¹, Guillaume Kistler¹, Ian Horsfall¹ and Liz Girvan²

¹ Impact and Armour Group, Centre for Defence Engineering, Cranfield University, Defence Academy of the United Kingdom, Shrivenham, SN6 7ES, UK.

² Otago Centre for Electron Microscopy, University of Otago, Dunedin, New Zealand

I, Mark Helliker, hereby state that the work presented in the article presented in Chapter 4 is my own, and the co-authors only provided me with guidance on interpreting the research, technical assistance in conduction of the experiments and provided editorial input on the manuscript.

4.2 Introduction

With recent UK military operations in Afghanistan an increasing trend in injuries to the lower limbs were observed (e.g. (Ramasamy et al., 2009, Sharma et al., 2013, Ramasamy et al., 2014)). In response the UK Ministry of Defence (MOD) developed tiered levels of protection to the lower extremities such as the Tier 1 Pelvic Protection System (PPS) (Lewis et al., 2013) (Figure 4-1 - left) and improved protection in their Enhanced Protection Under Body Armour Combat Shirt (EP-UBACS) (Breeze et al., 2014) (Figure 4-1 - right). The benefit of providing hierarchical fragment protection has been discussed in the open literature (e.g. (Sakaguchi et al., 2009, Breeze et al., 2014)). This work suggested that significant protection could be afforded by only a few layers of ballistic protective fabric. Some of these items have been brought into service by the military of other nations and commercial examples of similar systems are readily available.

The degradation due to laundering of the fabrics used in the PPS and EP-UBACS was investigated for periods representative of a six month operational tour typical

between 2006 and 2013 (as discussed in Chapter 3). However, the final operational tour of the British Forces in Afghanistan⁸ was extended to nine months for operational reasons. There was evidence that the PPS and EP-UBACS would continue to provide the required level of fragmentation protection over a six month tour, but there was no supporting evidence to demonstrate that the performance would be maintained to the equivalent of nine months. As a result the Defence Science and Technology Laboratory (Dstl) conducted additional testing to determine the degradation of these garments due to laundering only, for the equivalent of a nine month operational tour. This study did not consider the effect of daily wear in addition to laundering over this simulated period.



Figure 4-1 Tier 1 Pelvic Protection (left) and EP-UBACS (right) (Crown Copyright 2012)

Ballistic protective clothing issued to the British Armed Forces during operations in Afghanistan used knitted silk and ultra-high molecular weight polyethylene

⁸ This rotation was termed Op HERRICK 20, for being the 20th rotation of troops on a tour of operations by British Forces in the Helmand Province of Afghanistan and took place in 2014.

(UHMWPE) felt to provide the base level of protection (Helliker et al., 2012, Breeze et al., 2013, Lewis et al., 2013). Other fabrics were of interest for this application and this study included a woven para-aramid.

The effect of the long term robustness of body armours for police and military users has been under investigation e.g. (DHB Armor Group, 2004, Withnall, 2010, Bourget et al., 2012). These studies attempted to identify the effect of ageing on body armour during service use. Due to the highly variable wear rates of the armours, no firm correlation was identified between armour age and performance. The armours investigated in these previous studies were not routinely laundered, therefore limited their use in the current study.

Studies have been conducted to develop artificial wear upon either armour systems or representative panels of fragment protective fabrics (Forster et al., 2009, Pinto et al., 2011). Whereas the studies by Forster and Pinto sought to replicate wear, the armours that were the focus of the studies were not routinely laundered and this aspect was not investigated.

As combat clothing is a next-to-the-skin item, there is a need to launder garments incorporating fragment protective fabrics. Recent work on the effect of laundering and wear on the fragment protective properties of fabrics incorporated in combat uniforms has shown their resilience to wear and laundering (Pinto et al., 2011, Helliker et al., 2014). Published work on the effect of laundering has focussed on one

laundering regime, representative of a typical laundering cycle on military operations (Helliker et al., 2014). However, there is a need to understand the effect of wash temperature on the ballistic protective performance of these fabrics.

The effect of wash temperature during laundering has been shown to have an effect on knitted fabrics made of silk (Quaynor et al., 2000, Van Amber et al., 2010). These studies compared the effect of laundering temperature on knitted silks. These studies reported that a wash temperature of 35 °C induced greater shrinkage than laundering with a wash temperature of 60 °C. As UHMWPE and para-aramid fabrics were not typically laundered, there was a dearth of research available in the open literature at the time of this study.

In a response to a request for information (RFI) on laundering practices in British bases in Afghanistan (Lewis, 2010), it was identified that some Forward Operating Bases (FOB) were using cement mixers to wash combat clothing, where domestic laundering facilities were unavailable (e.g. Figure 4-2). A research project was initiated within Dstl to investigate the effect of washing fragment protective clothing using a cement mixer.

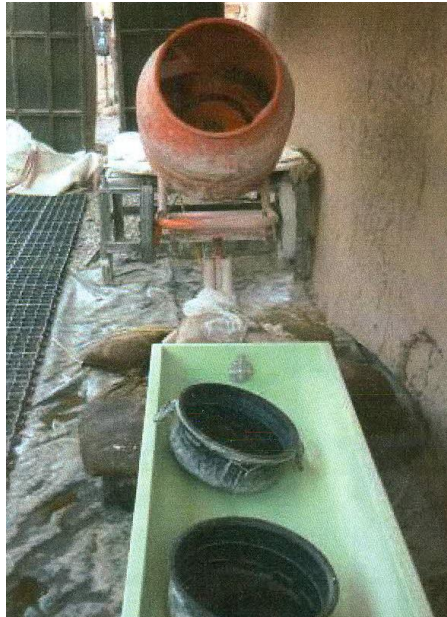

Figure 4-2 Laundry equipment including cement mixer, trough and buckets, typically used in UK forward operating base- Afghanistan (Crown Copyright 2010)

The aim of this work was to determine if the wash temperature affected selected properties of the selected fabrics, whether the degradation would significantly increase if the simulated duration was increased to nine months and whether the degradation induced by laundering using a cement mixer was different to that observed using domestic appliances.

4.3 Materials and methods

The effects of laundering temperature on three fragment protective fabrics were assessed in this study. Five sets of specimens were prepared for each fabric. Two sample panels were constructed for each set (ten in total) per fabric type. The sample panels were constructed of two layers of fragment protective fabric and were

covered front and back using two layers of fabric in a multi terrain pattern (MTP) polyester-cotton fabric (70% polyester 30% cotton; twill 3/1; 12 x 12 yarns / 10 mm, mean mass per unit area $188 \pm 0.8 \text{ g/m}^2$). The sample panels were cut into square panels (measuring 500 x 500 mm) and secured using quilting using stitch type 301 every 100 mm in both X and Y directions (e.g. Figure 4-3), through the ballistic protective fabric, before being enclosed in the polyester cotton cover (British Standards Institute, 1991). The edges of the panels were stitched together using an overlock stitch type 502 (British Standards Institute, 1991). Panels were marked according to ISO 3759:2011 to determine dimensional change (British Standards Institute, 2011).

Three fragment protective fabrics were assessed in this study:

- double jersey interlock knit silk, mean mass per unit area $152 \pm 3 \text{ g/m}^2$
- hydro-entangled UHMWPE felt, mean mass per unit area $181 \pm 8 \text{ g/m}^2$
- woven para-aramid, mean mass per unit area $196 \pm 0.8 \text{ g/m}^2$

The silk and polyethylene fabrics were loom state. The woven para-aramid had been scoured by the manufacturer before construction of the sample panels. No treatments were applied to the three ballistic protective fabrics used.



Figure 4-3 Example Test Specimen

4.3.1 Excursions

Two panels were used for each fabric and for each of the conditions. A summary of the conditioning regimes is provided in Table 4-1, and are detailed below:

- Two panels of each fabric were not-laundered and formed the baseline set for this study (NL).
- The second, third and fourth sets were laundered i.e. washed and tumble dried with a wash temperature on the 40 °C (L40) or 90 °C (L90 and L90E) settings and tumbled dried on a high heat setting. These temperatures were chosen to represent typical wash cycles used for military clothing. Washing cycles used 50 g of laundry detergent⁹ for 27 cycles using a Zanussi (ZWNB 6120 L) washing machine with a manually set 15 min wash cycle, a 10 min rinse cycle and a 10 min spin cycle (total wash cycle 35min, representative of

⁹ Detergent Laundry (Non Bio, Low Foam) NATO Stock Number: 7930992251626

a “quick wash”). The spin speed was set at 1200 rpm. Panels were dried after each washing cycle using a Hotpoint TVM570 tumble drier (high heat setting, for approximately 30 minutes). These conditions are recommended on the PPS garment’s care label. Twenty-seven cycles was chosen to represent a typical number of laundering cycles over the course of a six month deployment, assuming laundering once a week.

- The fifth set of panels was washed in a cement mixer (CM) (Figure 4-4). Washing cycles used 50 g of laundry detergent as per the other excursions for 27 cycles using a Clarke CCM126 cement mixer. Drum rotation was 28 revolutions per minute. Each cycle comprised of:
 - 10 l of Water was heated to a mean temperature of 60.3 °C¹⁰ (SD = 0.6 °C). Sample panels were added to the drum and the temperature measured (mean = 55.5 °C, SD = 1.8 °C) before an approximately 10 min wash cycle was initiated. The temperature was measured at the end of the wash cycle (mean = 36.9 °C, SD = 1.1 °C). Ambient temperature varied between 17 – 19 °C during washing cycles.
 - Water was drained and sample panels gently hand wrung before returning to drum for a rinse cycle (approximately 10 min), in 10 l of cold water (mean = 10.5 °C, SD = 1.0 °C).
 - Sample panels were then line dried.

¹⁰ This temperature was assessed to be the likely temperature achieved using a solar shower as identified through the Request for Information from the Deputy Scientific Advisor in Task Force Helmand - Lewis, E. 2010. Washing of Combat Clothing. Request for Information Serial H13RF007. Deputy Scientific Advisor, Head Quarters - Task Force Helmand.



Figure 4-4 Example of laundering with the cement mixer

Table 4-1 Summary of laundering excursions

Excursion	Wash Temperature Setting (°C)	Wash Duration (min)	Drying Temperature Setting	Drying Duration (min)	Number of Cycles
NL	NA	NA	NA	NA	NA
L40	40	35	High	30	27
L90	90	35	High	30	27
L90E	90	35	High	30	45
CM	60	20	NA	Line dried	27

After the panels were conditioned by one of the three regimes, they were conditioned according to ISO 139: 2005 (20 °C ± 2 °C; 65 %R.H. ± 4 %R.H.) prior to testing

(British Standards Institute, 2005). Effects of the conditioning regimes (L40 and L90)

compared to NL were assessed by change in:

- Normalised¹¹ V_{50} ¹² performance against a 0.24 g (4 grain) chisel nosed fragment simulating projectile (FSP) (Stores and Clothing Research and Development Establishment, 1993);
- Dimensions of the panels as per BS EN 5077:2008 (British Standards Institute, 2008a), change in mass per unit area of each fabric as per BS EN 12127:1998 (British Standards Institute, 1998) and change in thickness of both the panels and the fabrics were measured using a Mitutoyu dial-thickness gauge in accordance with BS EN ISO 5084:1996 (British Standards Institute, 1997);
- Ball burst strength using a modified ball burst test based on BS EN 9073-5:2008 (British Standards Institute, 2008b);
- Change in the molecular bonds on the surface of the fibres was assessed using Fourier Transform Infra-Red (FTIR) Spectroscopy in the Near Infra-Red (NIR) region and the Mid Infra-Red (MIR) region.
- Fibre dimensions were measured and characteristics of damage assessed through field emission scanning electron microscopy (FESEM).

4.3.2 Change in ballistic performance

The effect of laundering on 0.24 g (4 grain) chisel nosed fragment simulating projectile (FSP) V_{50} data was determined. A Number 3 Enfield proof mount fitted with a 5.56 mm calibre (L85) barrel was used to fire the FSP. The FSP was mounted in a

¹¹ Data was normalised as the ballistic performance of military protective clothing is classified.

¹² The V_{50} is the velocity at which a given projectile has a statistical probability of 50% of perforating a target completely.

polymeric sabot to enable the 3.25 mm diameter FSP to be fired from a 5.56 mm calibre barrel. The velocity of the FSP was varied by adjusting the mass of Vihtavuori N330 propellant used in hand-loaded 5.56 x 45 mm L15A2 cartridge cases (manufactured by Radway Green). All panels were mounted on a square frame and secured using "A" clamps in the four corners only. Panels were placed approximately 5 m from the end of the muzzle (Figure 4-5). The strike and residual velocities of the FSP were measured using a Doppler radar system. FSPs were fired at each specimen in such a manner that no impact occurred within 50 mm of the specimen edge; 50 mm from a previous impact; and avoiding previously impacted warp, wale or 'x' and weft, course and 'y' yarns or orientations (Ministry of Defence, 1994). Whether or not the FSP perforated the specimen was noted. During the tests the temperature and relative humidity were recorded (mean temperature: 20.6 °C, SD 1.5 °C; mean relative humidity: 33.6%, SD 4.8%), along with the charge mass and the velocity of the projectile.

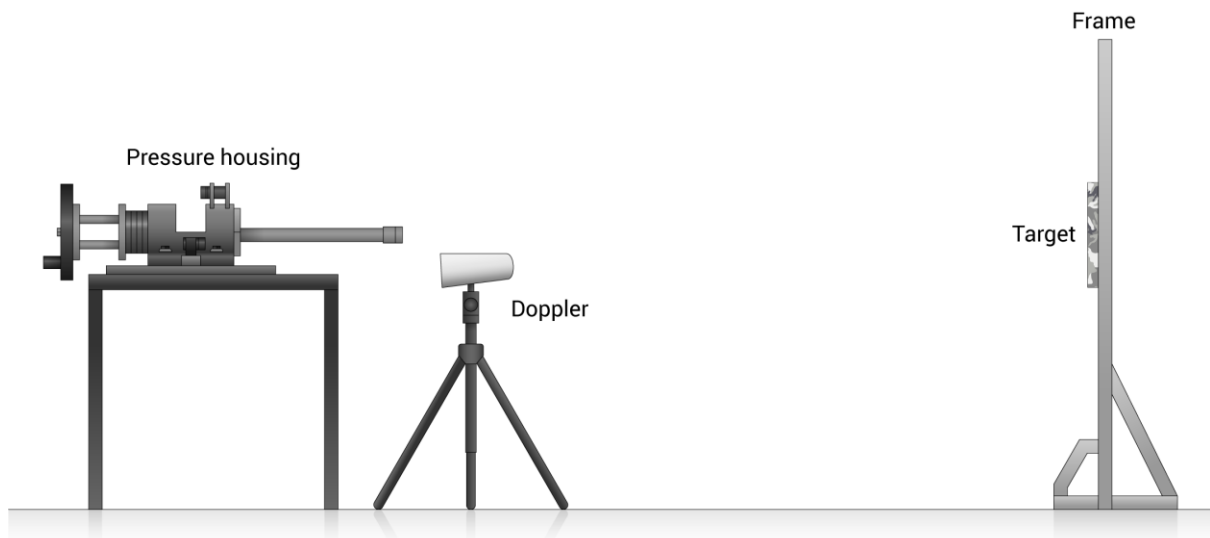

Figure 4-5 Range set-up used in the ballistic trials (Copyright 2017, Cranfield University Media)

Estimated 0.24 g FSP V_{50} data were calculated using the bias reduced generalised linear model (BRGLM) (Kosmidis, 2007) implemented in the R statistical software package (R Core Team, 2012). The BRGLM calculates the V_{50} based on the probit statistical method (Bliss, 1934, Fisher, 1935, Finney, 1971, McCullagh et al., 1989, Firth, 1993). Using the BRGLM, the standard error and the 95th percentile confidence limits of each V_{50} were calculated. This model was used to compare the effect of L40 and L90 conditions compared to NL, to determine if there was a difference in the V_{50} for each condition. A Wald significance test (Draper et al., 1998) was run on the model parameters to determine if differences in the measured V_{50} and slope of the cumulative probability curve were statistically significant.

4.3.3 Modified ball burst test

The resistance to penetration for non-woven fabrics (ball burst test) is described in BS EN 9073-5:2008 (British Standards Institute, 2008b). The standard test utilises a probe with a spherical head of diameter 25.4 mm and a mounting ring with an internal diameter of 44.5 mm. This setup was modified to be more representative of the ballistic testing. The probe diameter was reduced to 3.25 mm (the same diameter as the FSP used in this study), and the internal diameter of the mounting ring was reduced to 5.7 mm to ensure the same probe to internal ring diameter ratio (0.57:1) (Figure 4-6). The profile of the probe was altered to a flat ended cylinder, to replicate the squared cutting edges of the FSP and thereby reducing slippage between the yarns and the probe. Fabric samples were cut into approximately 50 x 50 mm squares ensuring that samples were secured evenly around the test area. The mounting ring and probe were set up in an INSTRON 5567 tensile testing machine and samples were clamped on four sides using M6 bolts. The clamping bolts for silk and UHMWPE samples were tightened to 10 Nm and para-aramid samples were tightened to 5 Nm (in order to prevent the cutting of yarns at the edge of the test area).

The probe speed was set to 300 mm/min, as directed in the standard and a 10 kN load cell was used in the testing. Instances of yarn slippage through the mounting ring were noted and those results were omitted from the results (as directed in BS

EN 9073-5:2008). The ball burst strength from six samples from each set of excursions was recorded and the mean and 95% confidence intervals calculated. An analysis of variance test was applied to the results to determine if there was a significant difference between the different conditioning regimes and the NL baseline. Where results showed a significant difference a post hoc Tukey pairwise comparison was conducted to determine where the differences between each conditioning regime were, using the “R” statistical software package version 2.15.2.

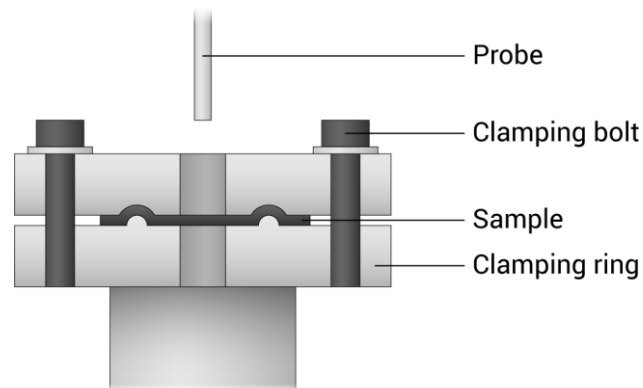

Figure 4-6 Experimental setup for the ball burst test (Copyright 2017, Cranfield University Media)

4.3.4 FTIR

Analysis of the surface chemistry of the fibres was conducted using a Nexus FTIR, in the NIR range ($11,000\text{ cm}^{-1}$ to $4,000\text{ cm}^{-1}$ wave numbers). Further FTIR analysis in the mid-infrared (MIR) range ($4,000\text{ cm}^{-1}$ to 400 cm^{-1} wave numbers) was conducted using Bruker Alpha FTIR, with Platinum ATR module and results analysed using

Opus 7.2 (build 7,2,139,1294) software. As no treatments had been applied to the fibres and damage observed in previous work was to the surface of the fibres, it was determined that this analysis was sufficient to highlight any changes in the chemical bonds of the fibres through laundering (Helliker et al., 2014).

4.3.5 FESEM

Damage to the fabric samples was investigated using a JEOL 6700F field emission scanning electron microscope (FESEM; LEI detector, 3 kV, 8-17 mm working distance); samples were mounted on aluminium stubs with double sided carbon tape and sputter coated with gold palladium using Emitech K575X Peltier-cooled high resolution sputter coater. Imaging was conducted at Otago University, New Zealand by a laboratory technician experienced in imaging fabrics.

Images were taken from samples cut approximately 10mm x 10mm from the fabric and chosen to be more than 100 mm from any edge and not in an area disrupted by quilting or ballistic impact. One sample was cut for each laundering regime. Images were taken at x35, x500 and x2000 magnifications. Measurements of the fibre thicknesses were taken, but results were inconclusive due to high variance in measured fibre diameter.

Images were analysed to characterise the type of damage observed to the fibres. This was in order to determine if the type of damage observed was affected by laundering regime.

No assessment of the degree of damage was made for the images, as:

- Assessment methods such as those in BS EN ISO 12945-2:2000 (British Standards Institute, 2000) are qualitative measures using the following scale (Table 4-2). The scale was designed to be used on fabric swatches under examination by the naked eye, rather than images through an electron microscope and focussed on the fabric's appearance rather than the characterising the damage to the individual fibres.

Table 4-2 Visual Assessment of Damage to Fabric from BS EN ISO 12945-2:2000

Grade	Description
5	No change.
4	Slight surface fuzzing and/or partially formed pills.
3	Moderate surface fuzzing and/or moderate pilling. Pills of varying size and density partially covering the specimen surface.
2	Distinct surface fuzzing and/or distinct pilling. Pills of varying size and density covering a large proportion of the specimen surface.
1	Dense surface fuzzing and/or severe pilling. Pills of varying size and density covering the whole of the specimen surface.

For the purposes of this study the descriptions of damage to the fibres are described in Table 4-3:

Table 4-3 Visual Assessment of Damage from FESEM Imagery

Description
No change.
Lengthwise splitting of fibres
Localised separation of the fibrils within the fibres
Surface breakage of fibrils / peeling
Pills begin to form
Complete fibre break

- Although attempts were made to select areas representative of the fabric sample in general, degradation across the samples was not uniform and would be affected by proximity to quilted areas and the edge of the panel.
- Other more quantitative measures to assess degradation such as the modified ball burst test and ballistic assessment were made and a further qualitative measure was not considered necessary to characterise the degree of degradation.

4.4 Results

4.4.1 Ballistic results

The effect of laundering on ballistic performance is summarised in Table 4-4. Data for laundered specimens are normalised against results for non-laundered specimens¹³.

¹³ Actual performance data cannot be quoted as these relate to the protection afforded by in-service equipment and is classified information.

4.4.1.1 Silk

There was no evidence of a change in the ballistic protective performance of the knitted silk fabric from any of the regimes in comparison to the baseline, or between the L40 and L90, L90 and L90E or L90 and CM. Although the V_{50} results show a slight dip in performance compared to the other excursions, the differences are not statistically significant.

4.4.1.2 UHMWPE

There is some evidence of a change in ballistic protective performance of the felted UHMWPE fabric between the L40 and L90 laundering regime. However, there was no evidence of a difference in performance between either of these excursions and the baseline. The L90 regime showed a slight improvement in ballistic protective performance than the NL baseline and the L40 regime. There is also a similar difference between the L90 and the L90E regimes. This suggests that any minor improvement imparted to the fabric from the L90 laundering was negated after extended laundering (L90E). There was no evidence of a difference in performance between the fabric laundered in the cement mixer (CM) and either the L40 or L90 regimes.

4.4.1.3 Para-aramid

All four laundering regimes (L40, L90, L90E and CM) investigated in this chapter showed improved fragment protective performance compared to the baseline (NL).

The greatest improvement was observed after the L40 regime. A reduction in the performance between the L90 and L90E regimes was observed, suggesting that the greatest benefit was imparted before 45 laundering cycles (L90E). The performance of the fabric after L40 laundering rose most rapidly compared to L90 and CM regimes. It is expected that if the laundering had continued further reductions in performance would be observed. There was no evidence of a difference in performance between the L90 and CM regimes.

Table 4-4 V₅₀ Results

	Silk			UHMWPE			Para-aramid		
	Change in V ₅₀ (%)	SE (%)	p value	Change in V ₅₀ (%)	SE (%)	p value	Change in V ₅₀ (%)	SE (%)	p value
NL	100.0	4.0	-	100.0	3.1	-	100.0	5.5	-
L40	91.8	5.8	> 0.05 NL	96.9	3.1	> 0.05 NL	133.8	3.1	< 0.01 NL
L90	96.6	2.7	> 0.05 NL > 0.05 L40	105.1	2.0	> 0.05 NL < 0.05 L40	120.6	3.0	< 0.01 NL < 0.05 L40
L90E	100.6	2.9	> 0.05 NL > 0.05 L90	97.1	2.3	> 0.05 NL < 0.05 L90	115.6	5.1	< 0.05 NL > 0.05 L90
CM	96.6	2.8	> 0.05 NL > 0.05 L40 > 0.05 L90	102.0	3.3	> 0.05 NL > 0.05 L40 > 0.05 L90	116.9	4.5	< 0.01 NL < 0.01 L40 > 0.05 L90

4.4.2 Dimensional stability

The dimensional stability of the sample panels was assessed by measuring the dimensions in the X, Y and the thickness of the sample panels before and after laundering. The results are presented in Table 4-5, Table 4-6 and Table 4-7.

4.4.2.1 Silk

The knitted silk panels showed evidence of shrinking in both the X and Y directions after each laundering regime (L40, L90, L90E and CM). The greatest shrinkage was observed after the L40 regime. There was no evidence of a difference in the level of shrinkage of the silk panels between the L90 and the L90E or CM regimes. This showed that the panels were less affected by higher temperature washes and there was no evidence of the changes being cumulative within the range of laundering cycles investigated. The thickness of the panels was affected by all laundering regimes and showed an increase in panel thickness. There was no evidence that the degree to which the panels increased in thickness was more severely affected by any one of the laundering regimes.

4.4.2.2 UHMWPE

The dimensional stability of the UHMWPE panels were affected by all of the laundering regimes investigated. Significant shrinking of the panels in both the X and Y directions was observed and there was a corresponding increase in the thickness of the panels. There was no evidence of a difference in the degree of shrinkage in the X or Y dimensions between the L40 and L90 or CM regimes or between the L90 and L90E regimes. The same trends were observed in the thickness of the panels. This showed that after the initial change in dimension, further changes were not significant within the bounds investigated. In Addition there was no evidence that laundering with a cement mixer proved more degradative than laundering using

domestic appliances. Of the three fabrics investigated, the UHMWPE panels were more severely affected than either the silk or para-aramid panels. This is typical of felted fabrics and is comparable with the trends observed in Chapter 3.

4.4.2.3 Para-aramid

All the laundering regimes produced changes in the dimensional stability of the panels made using the para-aramid fabric. Panels laundered in the cement mixer were less affected than those using the L40 or L90 laundering regimes. In all cases panels shrank in both the X and Y directions, with a corresponding increase in panel thickness. The amount of shrinkage was less pronounced with the para-aramid panels than the UHMWPE or the silk panels.

Table 4-5 Dimensional change in panel X direction

	Silk			UHMWPE			Para-aramid		
	Change in X (%)	SE (%)	p value (F4,25 = 39.1)	Change in X (%)	SE (%)	p value (F4,25 = 84.7)	Change in X (%)	SE (%)	p value (F4,25 = 25.5)
NL	100.0	0.4	-	100.0	0.3	-	100.0	0.3	-
L40	94.5	0.3	< 0.01 NL	91.0	0.1	< 0.01 NL	96.5	0.2	< 0.01 NL
L90	96.0	0.2	< 0.01 NL < 0.01 L40	89.0	0.2	< 0.01 NL > 0.05 L40	96.0	0.1	< 0.01 NL > 0.05 L40
L90E	94.5	0.1	< 0.01 NL > 0.05 L90	88.5	0.7	< 0.01 NL > 0.05 L90	95.5	0.5	< 0.01 NL > 0.05 L90
CM	96.0	0.4	< 0.01 NL < 0.01 L40 > 0.05 L90	90.5	0.8	< 0.01 NL > 0.05 L40 > 0.05 L90	97.5	0.2	< 0.01 NL < 0.01 L40 > 0.05 L90

Table 4-6 Dimensional change in panel Y direction

	Silk			UHMWPE			Para-aramid		
	Change in Y (%)	SE (%)	p value (F _{4,25} = 24.0)	Change in Y (%)	SE (%)	p value (F _{4,25} = 50.7)	Change in Y (%)	SE (%)	p value (F _{4,25} = 69.0)
NL	100.0	0.4	-	100.0	0.3	-	100.0	0.1	-
L40	93.0	0.4	< 0.01 NL	91.0	0.3	< 0.01 NL	96.0	0.4	< 0.01 NL
L90	95.0	0.2	< 0.01 NL < 0.01 L40	90.5	0.6	< 0.01 NL > 0.05 L40	96.0	0.1	< 0.01 NL < 0.01 L40
L90E	95.0	0.2	< 0.01 NL > 0.05 L90	88.5	0.6	< 0.01 NL > 0.05 L90	95.5	0.1	< 0.01 NL > 0.05 L90
CM	96.0	0.4	< 0.01 NL < 0.01 L40 > 0.05 L90	91.0	0.7	< 0.01 NL > 0.05 L40 > 0.05 L90	97.5	0.2	< 0.01 NL < 0.01 L40 > 0.05 L90

Table 4-7 Dimensional change in panel thickness

	Silk			UHMWPE			Para-aramid		
	Panel Thickness (%)	SE (%)	p value (F _{4,25} = 128.1)	Panel Thickness (%)	SE (%)	p value (F _{4,25} = 10.4)	Panel Thickness (%)	SE (%)	p value (F _{4,25} = 14.3)
NL	100.0	17.1	-	100.0	3.0	-	100.0	2.6	-
L40	122.5	0.5	< 0.01 NL	127.0	4.0	< 0.05 NL	114.5	2.5	< 0.05 NL
L90	124.5	1.5	< 0.01 NL > 0.05 L40	138.5	7.2	< 0.01 NL > 0.05 L40	110.0	2.3	< 0.05 NL > 0.05 L40
L90E	131.5	1.0	< 0.01 NL > 0.05 L90	139.5	4.4	< 0.01 NL > 0.05 L90	111.0	3.3	< 0.01 NL > 0.05 L90
CM	126.5	1.3	< 0.01 NL > 0.05 L40 > 0.05 L90	129.5	3.1	< 0.05 NL > 0.05 L40 > 0.05 L90	114.0	6.8	< 0.01 NL < 0.05 L40 < 0.05 L90

4.4.3 Change in mass per unit area and thickness of fabric

Laundering affected the mass per unit area of all fabrics (Table 4-8). There was evidence that there was a greater increase in mass per unit area for the silk fabric

laundered at 90 °C and in the cement mixer in comparison with laundering at 40 °C. The change in mass per unit area of the silk fabric increased with extended laundering (L90E). The same trends were observed with the para-aramid fabric, although there was no evidence that extended laundering (L90E) increased the change in mass per unit area of the fabric beyond the L90 laundering regime. The para-aramid fabric was less affected than the other two fabrics, though as the para-aramid felt in Chapter 3 showed a similar dimensional change as the UHMWPE felt, this relative stability is likely to be due to the woven structure rather than the fibre type.

There was no evidence of a change in mass per unit area between the L40 and L90 conditions. The L90E showed increased change in mass per unit area above that seen in the L90 condition and this was similar to the change observed in the fabric laundered in the cement mixer (CM). It is not known why the mass per unit area of the UHMWPE felt was more affected by laundering in the cement mixer, as these results seem at odds with the measured thickness of the fabrics.

The changes in mass per unit area correlate with the change in thickness and the dimensional change of the panels.

Table 4-8 Mass per unit area of the selected fabrics

	Silk			UHMWPE			Para-aramid		
	Mass per unit area (%)	SE (%)	p value ($F_{4,35} = 66.6$)	Mass per unit area (%)	SE (%)	p value ($F_{4,35} = 9.3$)	Mass per unit area (%)	SE (%)	p value ($F_{4,35} = 78.3$)
NL	100.0	0.9	-	100.0	2.3	-	100.0	0.2	-
L40	108.7	1.1	<0.01 NL	114.3	4.0	>0.05 NL	102.9	0.2	<0.01 NL
L90	116.0	0.6	<0.01 NL <0.01 L40	112.1	4.7	>0.05 NL >0.05 L40	103.6	0.1	<0.01 NL >0.05 L40
L90E	120.9	0.9	<0.01 NL <0.01 L90	132.4	5.3	<0.01 NL <0.05 L90	103.9	0.3	<0.01 NL >0.05 L90
CM	115.7	0.6	<0.01 NL <0.01 L40 >0.05 L90	131.3	5.5	<0.01 NL >0.05 L40 <0.05 L90	104.1	0.3	<0.01 NL <0.01 L40 >0.05 L90

The results of in the change in thicknesses of the selected fabrics are presented in Table 4-9. The thicknesses of all three fabrics increased due to laundering. The change in thicknesses of the silk and para-aramid fabrics were affected by wash temperature, with washing at 90 °C imparting a greater change. Extended laundering (L90E) of all three fabrics increased the thickness of the fabrics above the L90 condition. Both the silk and the para-aramid fabrics showed increased thickness after laundering in a cement mixer than either the L90 or L40 conditions.

There was no evidence of a difference between the two wash temperatures (L40 and L90) or the laundering with the cement mixer on the thickness of the UHMWPE fabric. Extended laundering (L90E) showed increased thickness in the UHMWPE fabric.

Table 4-9 Thicknesses of the selected fabrics

	Silk			UHMWPE			Para-aramid		
	Fabric Thickness (%)	SE (%)	p value (F _{4,115} = 314.4)	Fabric Thickness (%)	SE (%)	p value (F _{4,115} = 17.5)	Fabric Thickness (%)	SE (%)	p value (F _{4,115} = 171.3)
NL	100.0	0.6	-	100.0	6.4	-	100.0	0.2	-
L40	111.1	0.8	< 0.01 NL	105.7	4.8	> 0.05 NL	111.9	0.4	< 0.01 NL
L90	120.8	0.4	< 0.01 NL < 0.01 L40	110.0	5.6	< 0.05 NL > 0.05 L40	114.3	0.3	< 0.01 NL > 0.05 L40
L90E	126.7	0.7	< 0.01 NL < 0.01 L90	132.1	8.7	< 0.01 NL < 0.01 L90	127.2	0.5	< 0.01 NL < 0.01 L90
CM	125.1	0.5	< 0.01 NL < 0.01 L40 < 0.01 L90	112.1	7.1	< 0.05 NL > 0.05 L40 > 0.05 L90	121.3	0.6	< 0.01 NL < 0.01 L40 < 0.01 L90

4.4.4 Ball burst strength

The strength of the selected fabrics was measured using the modified ball burst test.

The change in ball burst strength is presented in Table 4-10.

The ball burst strength of the silk fabric was most affected by the L40 conditioning.

There was no evidence that there was a change in the ball burst strength for the silk fabric with extended laundering or between the L90 and CM conditions.

Although there appears to be some difference between the laundering regimes and the baseline for the UHMWPE and the para-aramid fabrics, the results are not statistically significant and it is not possible to draw firm conclusions from these results. Increases in the ball burst strength of the UHMWPE and the para-aramid fabrics due to laundering are possibly due to the increased mass per unit area of the

fabrics observed. The increase in mass per unit area would result in a greater amount of fabric being in the path of the probe during the test, resulting in higher ball burst strength. There appears to be a decrease in the ball burst strength between the L90 and L90E conditions, suggesting that the strength of the fabrics may be decrease beyond the 27 cycles of the L90 condition.

Table 4-10 Ball burst strength

	Silk			UHMWPE			Para-aramid		
	Mean Ball Burst Strength (%)	SE (%)	<i>p</i> value (F _{4,25} = 9.40)	Mean Ball Burst Strength (%)	SE (%)	<i>p</i> value (F _{4,25} = 1.98)	Mean Ball Burst Strength (%)	SE (%)	<i>p</i> value (F _{4,25} = 2.75)
NL	100.0	5.9	-	100.0	10.1	-	100.0	5.5	-
L40	65.5	4.0	< 0.01 NL	109.9	2.0	NS	117.6	4.0	NS
L90	87.8	2.4	> 0.05 NL < 0.01 L40	128.2	7.4	NS	107.2	6.5	NS
L90E	84.7	4.0	> 0.05 NL > 0.05 L90	112.0	4.7	NS	97.8	4.5	NS
CM	88.4	2.4	> 0.05 NL < 0.01 L40 > 0.05 L90	109.7	7.4	NS	101.3	6.5	NS

4.4.5 FTIR

The results from the FTIR spectroscopy for the silk, UHMWPE and para-aramid fabrics showed that for each of the fabrics there is no evidence of a change in the chemical bonds identified in either the NIR or the MIR ranges. Results from the spectroscopy can be found in APPENDIX C.

4.4.6 FESEM

FESEM images for the silk fabric are presented in Figure 4-7 to Figure 4-9 for NL (a), L40 (b), L90 (c), L90E (d) and CM (e).

Laundering appears to have caused minor disruption to the alignment of the knits within the fabric structure. In all laundered conditions (L40, L90, L90E and CM), the silk fibres show the same types of degradation. The surface of the fibres are visibly degraded and this degradation is focussed on the surface of the fabric, and fibres within the knit appear undamaged. The fibres show surface peeling and fibrillation. When observing the images, there did not appear to be any instances of complete fibre break. This would support findings of research in the open literature (Quaynor et al., 2000). This suggested that the damage to the fabric from both laundering regimes was minor, and was unlikely to have had a great impact upon the fabric strength.

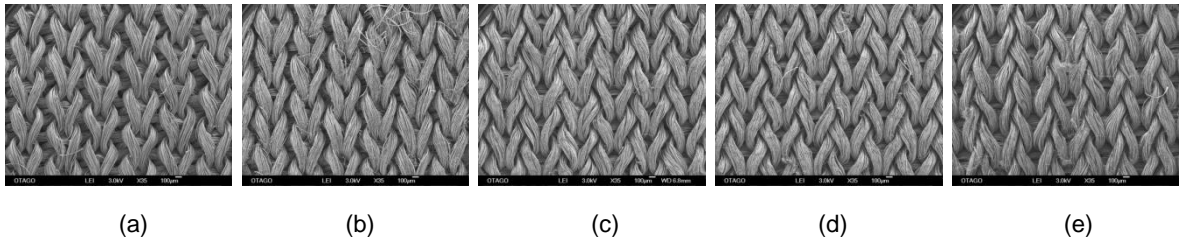

Figure 4-7 Silk (x35 magnification) NL (a), L40 (b), L90 (c), L90E (d) and CM (e)

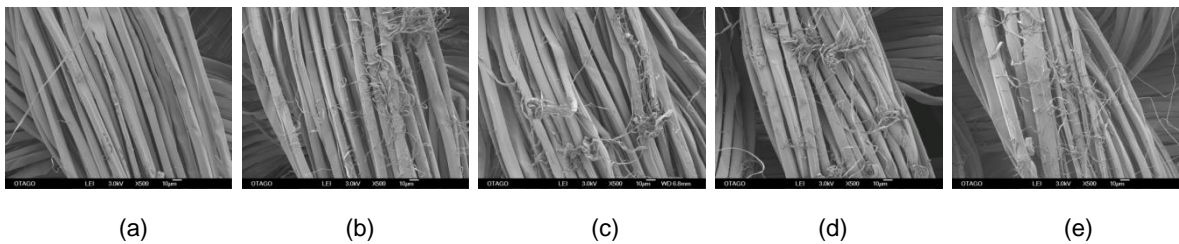

Figure 4-8 Silk (x500 magnification) NL (a), L40 (b), L90 (c), L90E (d) and CM (e)

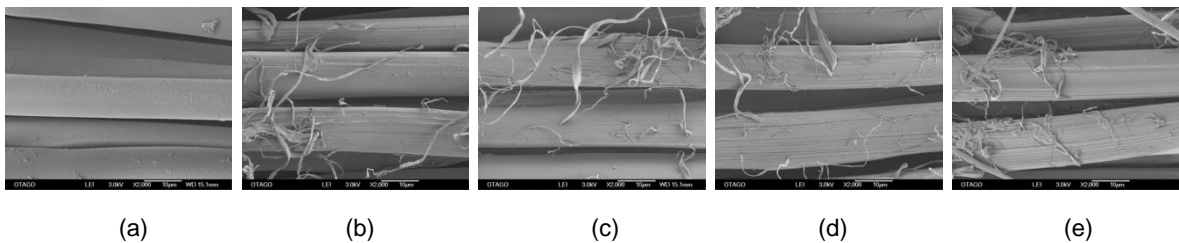

Figure 4-9 Silk (x2000 magnification) NL (a), L40 (b), L90 (c), L90E (d) and CM (e)

The images from the FESEM analysis of the UHMWPE fabric are presented in Figure 4-10 to Figure 4-12. NL (a), L40 (b), L90 (c), L90E (d) and CM (e).

At low magnification (x35) there did not appear to be a difference between the NL baseline and the four laundered conditions. At higher magnifications it could be seen

that damage due to laundering of the fibres was similar to that observed in Chapter 3. Damage to the fibres through all of the laundering regimes was characterised by localised swelling/separation of the fibrils of the fibres and longitudinal splitting. There did not appear to be any occurrence of fibre breaks within the felt from any of the laundering regimes investigated. Some localised swelling of the fibres was visible in the NL fabric, as well as the four conditioned samples. No difference in the severity of damage to the fibres between the conditioned fabrics was observed.

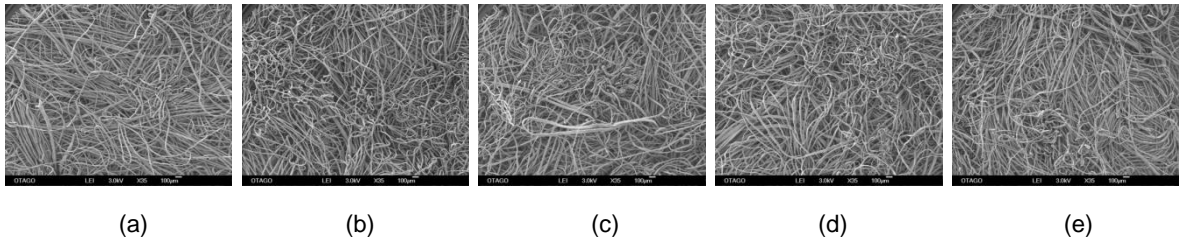

Figure 4-10 UHMWPE (x35 magnification) NL (a), L40 (b), L90 (c), L90E (d) and CM (e)

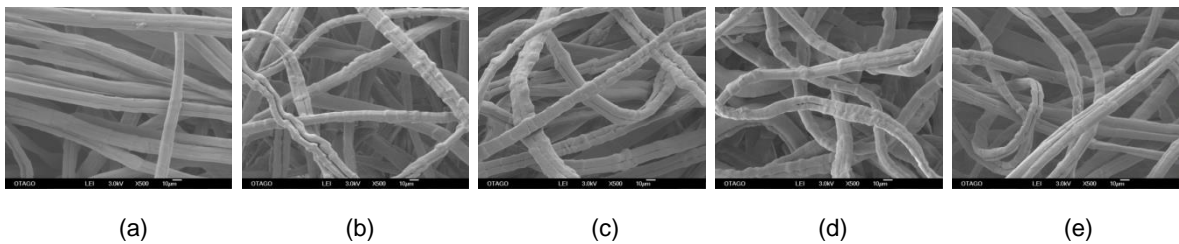

Figure 4-11 UHMWPE (x500 magnification) NL (a), L40 (b), L90 (c), L90E (d) and CM (e)

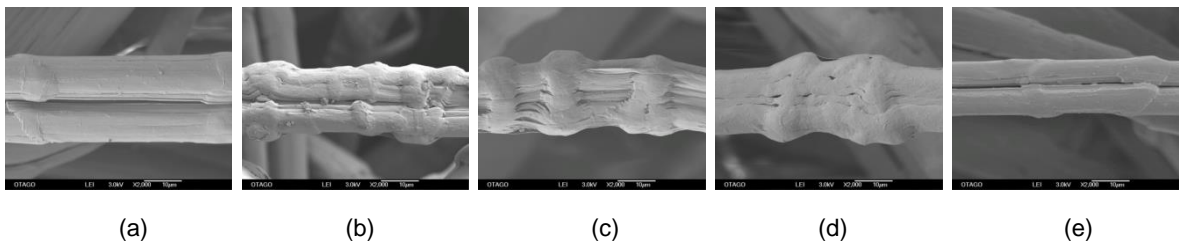
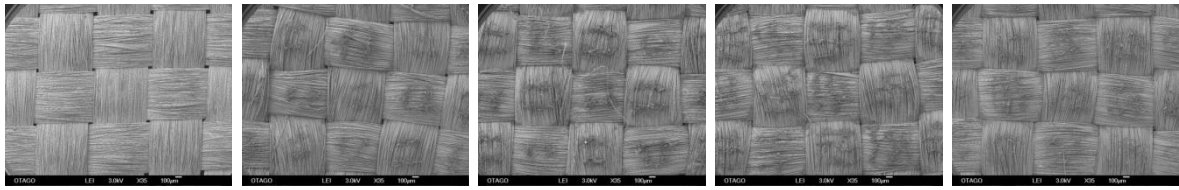

Figure 4-12 UHMWPE (x2000 magnification) NL (a), L40 (b), L90 (c), L90E (d) and CM (e)

Images from the FESEM analysis of the para-aramid fabric are presented in Figure 4-13 to Figure 4-15. The images show the NL (a), L40 (b), L90 (c), L90E (d) and CM (e). From Figure 4-13, it could be seen that the alignment of the weave after laundering had been disrupted. Fibrillation of the fibres can be seen on the surface of

the fabric, with no observable damage to the fibres deeper within the yarns / weave.

At higher magnifications (Figure 4-14 and Figure 4-15), the damage to the fibres was consistent across all of the laundering regimes, with surface peeling of the upper fibres leading to fibrillation and there was some evidence of the formation of pills on the surface of the yarns. No occurrence of fibres within the yarn breaking completely was observed and damage to the yarns was noted to be superficial.



(a) (b) (c) (d) (e)

Figure 4-13 Para-aramid (x35 magnification) NL (a), L40 (b), L90 (c), L90E (d) and CM

(e)

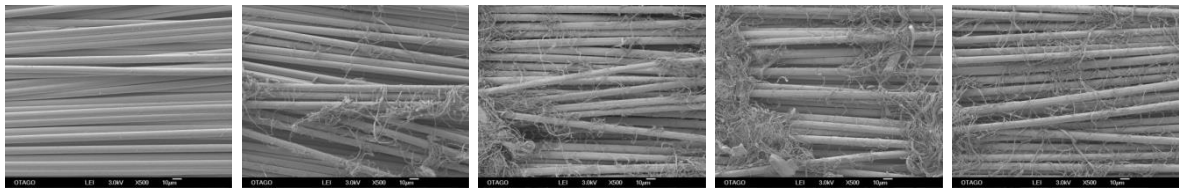

(a) (b) (c) (d) (e)

Figure 4-14 Para-aramid (x500 magnification) NL (a), L40 (b), L90 (c), L90E (d) and CM

(e)

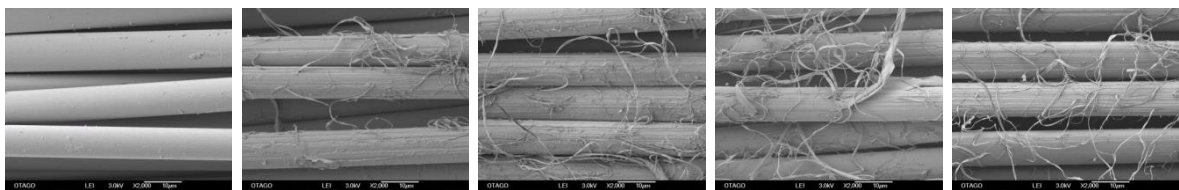

(a) (b) (c) (d) (e)

Figure 4-15 Para-aramid (x2000 magnification) NL (a), L40 (b), L90 (c), L90E (d) and CM

(e)

4.5 Discussion

4.5.1 Knitted silk

There was no evidence that any of the laundering regimes altered the ballistic protective performance of the silk fabric compared to the NL baseline. This was in contrast to the ball burst strength of the silk being more severely affected by the L40 laundering regime, whereas a greater change in dimension was observed after a L90 regime. These results are supported by the results presented by van Amber, who identified laundering at 40 °C to more severely affect the properties of knitted silk fabrics (Van Amber et al., 2010). This would suggest that a lower level of degradation may occur if the garment's care label were to recommend a 90 °C wash temperature.

Although the surfaces of the fibres were visibly damaged, this was not reflecting in a significant change in the ballistic results. The damage to the silk fabrics through both laundering regimes appeared to be as a result of surface abrasion of the fabric through inter-layer abrasion. Changes in the panel's dimensions and the fabric mass per unit area show that the fabrics shrank after laundering and that the effect was cumulative. Whereas the damage observed on the silk fibres was similar to the damage observed in the para-aramid, the lack of a change in ballistic performance is due to the difference in the structure of the fabric.

Laundering in the cement mixer compared to a domestic washing machine did not appear to have more severely affected the silk fabric.

The knitted fabrics interacted with the projectile differently compared to woven fabrics. There was less movement of the yarns over each other in the knitted fabric, as the knit naturally stretches during the impact event. As a result the surface texture of the fibres plays a less significant role than would be the case in a woven fabric structure. Although the visible damage was imparted to the fibres during laundering, the extent of the loss in strength of the fibres was not large enough to be measured by the techniques used in this study. An insufficient number of cycles were used to determine the point at which the damage to the fibres would begin to demonstrate an effect on ballistic protective performance. The results from this study showed that the silk fabric was more robust and it was reasonable to extend the expected service life of garments using the silk, based on the performance of the silk after the extended laundering.

4.5.2 Felted UHMWPE

For the UHMWPE, the two wash temperatures produced similar changes in the fabric properties. This suggests that the UHMWPE fabrics are insensitive to wash temperatures within the ranges used within this study.

Whilst the UHMWPE fabric showed an improvement in the ball burst strength after laundering, this was not reflected in the ballistic test results, which showed no change. This improvement in the ball burst strength may be related to the increased fabric thickness and mass per unit area measured. This would have allowed more fabric to engage with the probe during the test, thus increasing the strength of the fabric. The damage to the fibres within the UHMWPE fabric was characterised by longitudinal splitting of the fibres and localised swelling. The effect of laundering on the mass per unit area and thickness of the fabrics was cumulative. The cumulative effect will have implications for final garment design, where the dimensional stability of the garment may be affected by extended laundering and therefore limit the longevity of garments made using this fabric.

4.5.3 Woven Para-aramid

The ballistic protective performance of the para-aramid was increased by both laundering regimes, with laundering at 40 °C showing the greater improvement over the 90 °C. Laundering at the higher wash temperature resulted in greater shrinkage in the panel dimensions, but these results were not reflected by a difference in the mass per unit area or ball burst strength of the fabrics. From these results laundering with a wash temperature of 40 °C is preferable over laundering at 90 °C. The implications are that the higher wash temperature may have more severe implication for the dimensional stability of garments using para-aramid fabrics, whilst the lower

40 °C wash temperature provided the greater ballistic protective performance improvement.

The increase in ballistic performance of the para-aramid fabrics was greatest at the 27 cycles, after which the performance appeared to reduce for the 90 °C. This would suggest that the greatest improvement in ballistic performance occurred before 45 cycles for this laundering regime. The use of the cement mixer did not affect the para-aramid fabric as severely as the domestic laundering. Of the three fabric investigated, the para-aramid fabric showed an improvement in ballistic protective performance and the greatest dimensional stability. The damage to the para-aramid fabric appears to be caused by inter-layer abrasion as damage to the fibres is localised to the upper surface of the fabric. Little damage was visible further into the fabric or yarns. This damage appears to cause increased entanglement of the fibrils on the yarns.

4.6 Conclusions

This study showed that laundering imparted damage to the fabrics selected in this study. An insufficient number of laundering cycles were used in this study to reach a point where the ballistic protective performance of the selected fabrics would be measurably degraded. It was shown that laundering in a cement mixer imparted

similar degradation as laundering in domestic appliances. This demonstrated that the mechanisms by which degradation was imparted to the selected fabrics was independent of the laundering method. The fragment protective performance of the para-aramid was improved by laundering, irrespective of the laundering method used. These results support the earlier findings presented in Chapter 3. The damage imparted to the three fibres were identical to those previously presented in Chapter 3, primarily surface fibrillation and peeling in the silk and para-aramid fibres and longitudinal splitting and localised separation of the fibrils or swelling for the UHMWPE fibres.

Wash temperature affected the degradation of the silk and the para-aramid fabrics. The silk fabric was more affected more by laundering with a 40 °C wash temperature than laundering at 90 °C. The degradation of the para-aramid fabric was affected more by laundering with a wash temperature of 90 °C. In both cases the change in performance of the fabrics was minor. Wash temperature did not appear to affect the degradation of the UHMWPE fabric between the two wash temperatures investigated in this study.

The results have implications for the long term care of fragment protective garments utilising silk or para-aramid fabrics, with laundering at 90 °C imparting the least degradation for the knitted silk fabric and laundering at 40 °C offering the best performance for the para-aramid.

Laundering for the equivalent of nine months investigated in this study, the performance of the Tier 1 PPS and the EP-UBACS would be expected to continue to perform to the desired level.

This study did not consider the effect of daily wear on the performance of these fabrics. The implication of the results presented in this chapter was that the fabrics under investigation were more robust than the replacement policy for combat clothing in Afghanistan (2006 – 2014) would imply. It would be reasonable to extend the service life of the garments to nine months on operations based on the data presented.

4.7 Acknowledgments

The authors acknowledge the assistance of Mr Adrian Randall (DE&S) for information regarding the fabrics used in combat clothing and providing the fabric used in this research.

4.8 References

Bliss, C. I. 1934. The method of probits. *Science*, 79(2037):38-39.

Bourget, D., Withnall, C., Palmer, S., et al. 2012. Aged Body Armour Testing: Further Results. *Personal Armour Systems Symposium 2012*. Nuremburg, Germany. .

Breeze, J., Granger, C. J., Pearkes, T. D., et al. 2014. Ergonomic assessment of enhanced protection under body armour combat shirt neck collars. *Journal of the Royal Army Medical Corps*, 160(1):32-37.

Breeze, J., Helliker, M. & Carr, D. J. 2013. An integrated approach towards future ballistic neck protection materials selection. *Proceedings of the Institution of Mechanical Engineers, Part H: Journal of Engineering in Medicine*, 227:581-587.

British Standards Institute. BS 3870-1:1991 Stitches and seams part 1: classification and terminology of stitch types (ISO 4915:1991). 1991. BS 3870-1:1991.

British Standards Institute. BS EN ISO 5084:1997 Textiles - Determination of thickness of textiles and textile products 1997. BS EN ISO 5084:1997.

British Standards Institute. BS EN 12127 : 1998 Textiles - Fabrics - Determination of mass per unit area using small samples 1998. BS EN 12127 : 1998.

British Standards Institute. BS EN ISO 12945-2:2000 Textiles - Determination of fabric propensity to surface fuzzing and to pilling Part 2: Modified Martindale method. 2000. BS EN ISO 12945-2:2000.

British Standards Institute. BS EN ISO 139:2005 Textiles - Standard atmospheres for conditioning and testing +A1:2011. 2005. BS EN ISO 139:2005.

British Standards Institute. BS EN ISO 5077:2008 Textiles - Determination of dimensional change in washing and drying. 2008a. BS EN ISO 5077:2008.

British Standards Institute. BS EN ISO 9073-5:2008 Textiles - Test methods for nonwovens Part 5: Determination of resistance to mechanical penetration (ball burst procedure) (ISO 9073-5:2008). 2008b. BS EN ISO 9073-5:2008.

British Standards Institute. BS EN ISO 3759:2011 Textiles - Preparation, marking and measuring of fabric specimens and garments in tests for determination of dimensional change 2011. BS EN ISO 3759:2011.

DHB Armor Group. 2004. DHB Armor Group Armor Safety Report. DHB Industries Inc. USA.

Draper, N. R. & Smith, H. 1998. *Applied Regression Analysis*, New York, John Wiley & Sons Inc.

Finney, D. J. 1971. *Probit Analysis*, Cambridge, Cambridge University Press.

Firth, D. 1993. Bias reduction of maximum likelihood estimates. *Biometrika*, 80:27-38.

Fisher, R. A. 1935. Appendix to Bliss (1935). *Annals of Applied Biology*, 22(4):164-165.

- Forster, A. L., Messin, G. H. R. & Pintus, P. 2009. Development of Soft Armor Conditioning Protocols for NIJ Standard-0101.06: Analytical Results. National Institute of Standards and Technology.
- Helliker, M., Carr, D., Lankester, C., et al. 2014. Effect of domestic laundering on the fragment protective performance of fabrics used in personal protection. *Textile Research Journal*, 84(12):1298-1306.
- Helliker, M., Carr, D. J., Lankester, C., et al. 2012. Effect of laundering on the fragment protective performance of single jersey knit silk used in personal protection. *Personal Armour Systems Symposium*. Nuremburg, Germany.
- Kosmidis, I. 2007. *brglm: Bias reduction in binary-response GLMs* [Online]. Available: <http://go.warwick.ac.uk/kosmidis/software>.
- Lewis, E. 2010. Washing of Combat Clothing. Request for Information Serial H13RF007. Deputy Scientific Advisor, Head Quarters - Task Force Helmand.
- Lewis, E. A., Pigott, M. A., Randall, A., et al. 2013. The development and introduction of ballistic protection of the external genitalia and perineum. *Journal of the Royal Army Medical Corps*, 159(Supp I):i15-i17.
- McCullagh, P. & Nelder, J. A. 1989. *Generalized Linear Models*, London, Chapman and Hall.
- Ministry of Defence. UK/SC/5449 Ballistic test method for personal armours and lightweight materials. 1994.
- Pinto, R., Carr, D. J., Helliker, M., et al. 2011. Degradation of military body armour due to wear: laboratory testing. *Textile Research Journal*, 82(11):1157-1163.

- Quaynor, L., Takahashi, M. & Nakajima, M. 2000. Effects of Laundering on the Surface Properties and Dimensional Stability of Plain Knitted Fabrics. *Textile Research Journal*, 70(1):28-35.
- R Core Team 2012. *R: A language and environment for statistical computing*, Vienna, R Foundation for Statistical Computing.
- Ramasamy, A., Hill, A. M. & Clasper, J. C. 2014. Improvised Explosive Devices: Pathophysiology, Injury Profiles and Current Medical Management. *Journal of the Royal Army Medical Corps*, 155(4):265-272.
- Ramasamy, A., Hill, A. M., Hepper, A., et al. 2009. Blast Mines: Physics, Injury Mechanisms And Vehicle Protection. *Journal of the Royal Army Medical Corps*, 155(4):258-264.
- Sakaguchi, S. M., Carr, D. J., Horsfall, I., et al. 2009. Protecting the extremities of military personnel: fragment protective performance of one- and two-layer ensembles. *Textile Research Journal*, 82(12):1295-1303.
- Sharma, D. M., Webster, C. E., Kirkman-Brown, J., et al. 2013. Blast injury to the perineum. *Journal of the Royal Army Medical Corps*, 159(suppl 1):i1-i3.
- Stores and Clothing Research and Development Establishment. 1993. Fragment Simulating Projectile. A3/6723/3. Ministry of Defence.
- Van Amber, R. R., Niven, B. E. & Wilson, C. A. 2010. Effects of Laundering and Water Temperature on the Properties of Silk and Silk-blend Knitted Fabrics. *Textile Research Journal*, 80(15):1557-1568.

Withnall, C. 2010. Aged Armour Testing Study; Report on Results of 150 Samples.

DRDC Valcartier: CR 2010-117. Biokinetics and Associates Ltd. Ottawa,

Ontario, Canada.

5 THE CONTRIBUTION OF MOISTURE TO THE MECHANICAL WEAR AND DEGRADATION OF PERFORMANCE OF FRAGMENT PROTECTIVE FABRICS USED IN PERSONAL PROTECTION

5.1 General

From the research presented in Chapter 3, it was shown that the ballistic protective performance of the selected fabrics was not detrimentally affected by laundering. Improvement in the performance of the para-aramid fabrics showed some fibre types could benefit from enhanced performance as a result of laundering. Chapter 4 identified that wash temperature had minimal effect on the ballistic protective performance of the selected fabrics. The FTIR spectroscopy in both the NIR and MIR ranges demonstrated that there was no evidence of a change in the chemical bonds within the fibres for the selected fibres investigated in Chapter 4. Chapters 3 and 4 concluded that the change in ballistic protective performance was due to increased friction imparted upon the para-aramid fibres as a result of mechanical wear. The mechanical wear on the woven and knitted fabrics was characterised as surface damage to the fabrics due to the movement of fabric layers over each other during laundering. Chapter 4 identified that there was no evidence that the performance of the selected fabrics was significantly further degraded when the laundering was extended to the equivalent of nine months of operations. Chapter 4 identified that there was insufficient evidence of a degradative effect between washing in a cement mixer and domestic laundering. In this chapter, it was therefore necessary to

determine whether the level of mechanical wear in the fabrics was solely the result of mechanical tumbling or whether the presence of water in the laundering process was a significant contributing factor. This chapter compares the effect of 52 laundering cycles with the equivalent level of mechanical flexing of the test panels both dry and wet.

Note that this chapter is in the format of a submitted article and presented in its entirety. Therefore information in the introduction and previous chapters may be repeated within this chapter.

The contribution of moisture to the mechanical wear and degradation of performance of fragment protective fabrics used in personal protection

Mark Helliker¹, Debra Carr¹, Claire Lankester¹, Liz Girvan² and Ian Horsfall¹

¹ Impact and Armour Group, Centre for Defence Engineering, Cranfield University, Defence Academy of the United Kingdom, Shrivenham, SN6 7ES, UK.

² Otago Centre for Electron Microscopy, University of Otago, Dunedin, New Zealand

I, Mark Helliker, hereby state that the work presented in the article presented in Chapter 7 is my own, and the co-authors only provided me with guidance

on interpreting the research, technical assistance in conduction of the experiments and provided editorial input on the manuscript.

5.2 Introduction

The incorporation of low areal density panels of fragment protective fabric into combat clothing offers the potential to reduce the number and severity of fragment injuries on military operations (Sakaguchi et al., 2009). The UK Armed Forces first fielded the Tier 1 of the Pelvic Protection System (PPS) in 2010 (Lewis et al., 2013) and the enhanced protection under body armour combat shirt (EP-UBACS) in 2013 (Breeze et al., 2014) (Figure 5-1). The development of these garments was in response to the increasing numbers of casualties from buried improvised explosive devices (IEDs) on operations in Afghanistan (Ramasamy et al., 2009b, Ramasamy et al., 2010, Sharma et al., 2013, Ramasamy et al., 2014). The cause of injury to service personnel in recent operations was often from small fragments of relatively low velocity (Ramasamy et al., 2009a, Breeze et al., 2011, Breeze et al., 2013b, Breeze et al., 2013c). It was identified that a low level of fragment protection offered by a small number of layers of knitted silk or felted ultra-high molecular weight polyethylene (UHMWPE) could protect the wearer from a significant proportion of these fragments (Breeze et al., 2015).



Figure 5-1 Tier 1 Pelvic Protection (left) and EP-UBACS (right) (Crown Copyright 2012)

Traditionally fragment protective fabrics have been almost exclusively used in fragment protective body armour and helmets (Tobin et al., 2006). Typically body armour comprises of 20 – 40 layers of fragment protective fabrics, which are protected by either a waterproof or water-resistant and ultra-violet light resistant cover. These covers have been incorporated as a result of work investigating the degradation of performance of these fabrics when exposed to moisture (e.g. (Morrison et al., 1978, Bazhenov et al., 1999, Bazhenov et al., 2012)) and ultra-violet light (e.g. (Zhang et al., 2006, Arrieta et al., 2011, Wang et al., 2012)). These protection measures are often impractical for a next-to-the-skin garment such as Tier 1 and EP-UBACS, and are therefore not included (Lewis et al., 2013, Breeze et al., 2014). The presence of moisture in the ballistic protective fabric increases inter-yarn friction and acts as a lubricant between the projectile and fabric reducing protective properties (Bazhenov et al., 1999, Li et al., 2015). Inter-yarn friction has been shown

to affect the ballistic protective performance of some fabrics (e.g. (Lyons et al., 1956, Hearle et al., 1981, Duan et al., 2005a, Duan et al., 2005b, Rao et al., 2009)).

Ballistic protective clothing in service with the British Armed Forces is afforded a basic level of protection provided by either a knitted silk or ultra-high molecular weight polyethylene (UHMWPE) felt (Helliker et al., 2012, Breeze et al., 2013a). As other next-to-the-skin items are developed and new concepts are being considered other fabrics are of interest to this study including woven para-aramid which is commonly used in military body armour. As these garments are next-to-the-skin, there is a need to be able to launder them i.e. wash and dry them. The long term robustness of these items is of interest to the UK Ministry of Defence (MOD) and a research programme into the effect of laundering on fabrics used in fragment protective clothing was initiated (Pinto et al., 2011, Helliker et al., 2014). Laundering is considered to be one of the most degradative agents that clothing is exposed to in use and can damage the fibres within a fabric (Slater, 1991, Hearle et al., 1998). This damage can result in a loss in tensile strength of the fibres and yarns within the fabric (e.g. (Eisenhut, 1941, Hördler et al., 1976)). Some work has identified that inter-yarn friction can be increased when the lubricants used in weaving/knitting are removed through processes such as scouring or laundering (Lyons et al., 1956, Morrison, 1984, Bazhenov, 1997, Bhatnagar, 2006). Other properties of fabrics, such

as dimensional change have been reported as a result of laundering (e.g. (Van Amber et al., 2010, Helliker et al., 2014)).

Previous work identified that the predominant form of degradation to silk and para-aramid fibres was through fibrillation and for UHMWPE through longitudinal splitting and localised swelling of the fibres (Helliker et al., 2014). It was concluded that mechanical wear appeared to be the main causative agent in the degradation of the fabrics when laundering.

The aim of the current study was to determine if mechanical wear in selected fabrics was increased when exposed to moisture and whether this was the main causative agent of degradation in ballistic protective performance in laundering, compared to mechanical wear in isolation. Ball burst strength, analysis of the bonds using Fourier Transform Infra-Red Spectrometry (FTIR) in the Mid Infra-Red (MIR) range, dimensional stability, thickness and mass per unit area were also measured for the three fabrics in this study.

5.3 Materials and methods

Three fragment protective fabrics were assessed in this study:

- double jersey interlock knitted silk, mean mass per unit area $152 \pm 3 \text{ g/m}^2$
- hydro-entangled UHMWPE felt, mean mass per unit area $181 \pm 8 \text{ g/m}^2$
- woven para-aramid, mean mass per unit area $196 \pm 0.8 \text{ g/m}^2$

The silk and UHMWPE fabrics were loom state. The woven para-aramid had been scoured by the manufacturer before construction of the panels. No treatments were applied to the three ballistic protective fabrics used.

The panels used were constructed of two layers of fragment protective fabric and were covered using two layers of a multi terrain pattern (MTP) polyester-cotton fabric (70% polyester 30% cotton; twill 3/1; 12 x 12 yarns / 10 mm, mean mass per unit area $188 \pm 0.8 \text{ g/m}^2$). The panels were 500 x 500 mm and were quilted using stitch type 301 every 100 mm in both X and Y directions (e.g. Figure 5-2), through the ballistic protective fabric, before being enclosed in the polyester cotton cover (British Standards Institute, 1991). The edges of the panels were stitched together using an overlock stitch type 502 (British Standards Institute, 1991). Panels were marked according to BS EN ISO 3759:2011 to determine dimensional change (British Standards Institute, 2011).



Figure 5-2 Example Sample Panel

5.3.1 Excursions

Two panels were used for each fabric and for each of the four conditions. A summary of the conditions are presented in Table 4-1. The four conditions were:

- Two panels of each fabric were not-laundered and this was used as the baseline for this study (NL).
- The second set was laundered i.e. washed and tumble dried (L). Washing cycles used 50 g of laundry detergent¹⁴ for 52 cycles using a Zanussi (ZWNB 6120 L) washing machine with a manually set 15 min wash cycle, a 10 min rinse cycle and a 10 min spin cycle (total wash cycle 35min, representative of a “quick wash”). The temperature of the wash was set at 40 °C, with spin speed of 1200 rpm. Each total wash cycle equated to approximately 612

¹⁴ Detergent Laundry (Non Bio, Low Foam) NATO Stock Number: 7930992251626

drum rotations. Panels were dried after each washing cycle using a Hotpoint TVM570 tumble drier (high heat setting, for approximately 30 minutes). Each 30 min drying cycle comprised of approximately 1740 drum rotations. Fifty-two cycles was chosen to represent a typical number of laundering cycles over the course of a year assuming laundering once a week.

- The third set of panels was tumbled without exposure to water on a low heat setting for the equivalent number drum rotations for the 52 laundering cycles (T).
- The fourth set of panels was washed without laundry detergent for the equivalent number of rotations for the 52 laundering cycles (approximately 122,300 drum rotations). Samples were line dried. (W)

Table 5-1 Summary of laundering excursions

Excursion	Wash Temperature Setting (°C)	Wash Duration (min)	Drying Temperature Setting	Drying Duration (min)	Number of Cycles
NL	NA	NA	NA	NA	NA
L	40	35	High	30	52
T	NA	NA	Low	NA	Approximately 122,000 drum rotations
W	40	NA	NA	NA	Approximately 122,000 drum rotations

After the panels were conditioned by one of the three regimes, they were conditioned according to BS EN ISO 139: 2005 (20 °C ± 2 °C; 65 %R.H. ± 4 %R.H.) prior to testing (British Standards Institute, 2005). Effects of the conditioning regimes (L, W and T) compared to NL were assessed by change in:

- Normalised¹⁵ V_{50} ¹⁶ performance against a 0.24 g (4 grain) chisel nosed fragment simulating projectile (FSP) (Stores and Clothing Research and Development Establishment, 1993);
- Dimensions of the panels as per BS EN 5077:2008 (British Standards Institute, 2008a), change in mass per unit area of each fabric as per BS EN 12127:1998 (British Standards Institute, 1998) and change in thickness of both the panels and the fabrics were measured using a Mitutoyu dial-thickness gauge in accordance with BS EN ISO 5084:1996 (British Standards Institute, 1997);
- Ball burst strength using a modified ball burst test based on BS EN 9073-5:2008 (British Standards Institute, 2008b);
- Fibre dimensions were measured and characteristics of damage assessed through field emission scanning electron microscopy (FESEM).

¹⁵ Data was normalised as the ballistic performance of military protective clothing is classified.

¹⁶ The V_{50} is the velocity at which a given projectile has a statistical probability of 50% of perforating a target completely.

5.3.2 Change in ballistic performance

The effect of laundering on 0.24 g (4 grain) chisel nosed fragment simulating projectile (FSP) V_{50} data was determined. A number 3 Enfield proof mount fitted with a 5.56 mm calibre (L85) barrel was used to fire the FSP. The FSP was mounted in a polymeric sabot to enable the 3.25 mm calibre FSP to be fired from a 5.56 mm calibre barrel. The velocity of the FSP was varied by adjusting the mass of Vihtavuori N330 propellant used in hand-loaded 5.56 x 45 mm L15A2 cartridge cases (manufactured by Radway Green). All panels were mounted on a square frame and secured using "A" clamps in the four corners only. Panels were placed approximately 5 m from the end of the muzzle (Figure 5-3). The strike and residual velocities of the FSP were measured using a Doppler radar system. FSPs were fired at each specimen in such a manner that no impact occurred within 50 mm of the specimen edge; 50 mm from a previous impact; and avoiding previously impacted warp, wale or 'x' and weft, course and 'y' yarns or orientations (Ministry of Defence, 1994). Whether or not the FSP perforated the specimen was noted. During the tests the temperature and relative humidity were recorded (mean temperature: 20.6 °C, SD 1.5 °C; mean relative humidity: 33.6%, SD 4.8%), along with the charge mass and the velocity of the projectile.

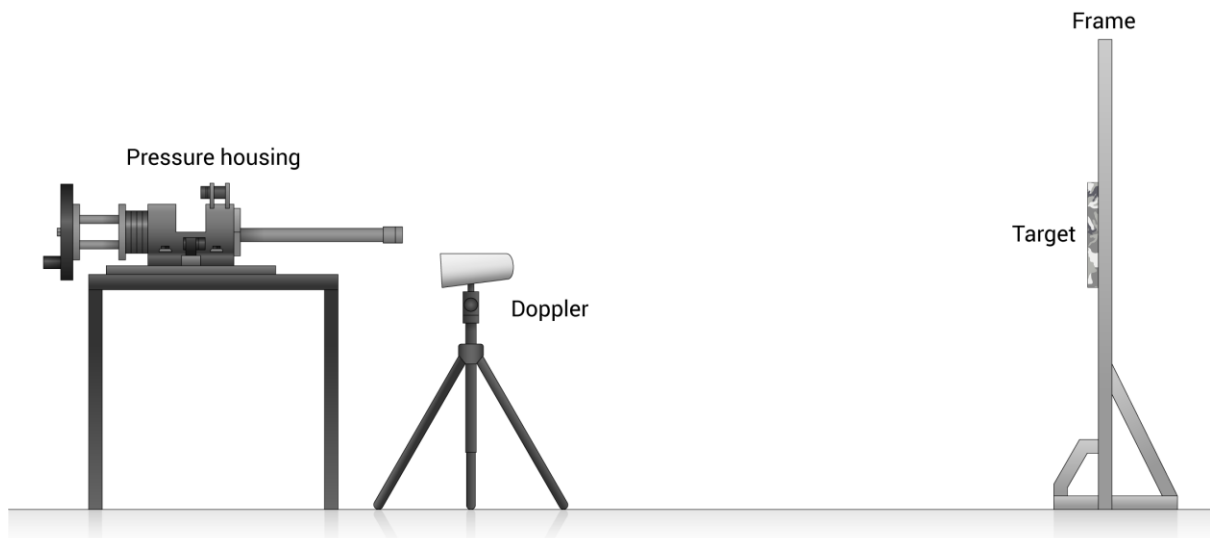

Figure 5-3 Range set-up used in the ballistic trials (Copyright 2017, Cranfield University Media)

Estimated 0.24 g FSP V_{50} data were calculated using the bias reduced generalised linear model (BRGLM) (Kosmidis, 2007) implemented in the R statistical software package (R Core Team, 2012). The BRGLM calculates the V_{50} based on the probit statistical method (Bliss, 1934, Fisher, 1935, Finney, 1971, McCullagh et al., 1989, Firth, 1993). Using the BRGLM, the standard error and the 95th percentile confidence limits of each V_{50} were calculated. This model was used to compare the effect of L, W and T conditions compared to NL, to determine if there was a difference in the V_{50} for each condition. A Wald significance test (Draper et al., 1998) was run on the model parameters to determine if differences in the measured V_{50} were statistically significant.

5.3.3 Modified ball burst test

The resistance to penetration for non-woven fabrics (ball burst test) is described in BS EN 9073-5:2008 (British Standards Institute, 2008b). The standard test utilises a probe with a spherical head of diameter 25.4 mm and a mounting ring with an internal diameter of 44.5 mm. This setup was modified to be more representative of the ballistic testing. The probe diameter was reduced to 3.25 mm (the same diameter as the FSP used in this study), and the internal diameter of the mounting ring was reduced to 5.7 mm to ensure the same probe to internal ring diameter ratio (0.57:1) (Figure 5-4). The profile of the probe was altered to a flat ended cylinder, to replicate the squared cutting edges of the FSP and thereby reducing slippage between the yarns and the probe.

Fabric samples were cut into approximately 50 x 50 mm squares ensuring that samples were secured evenly around the test area. The mounting ring and probe were set up in an INSTRON 5567 tensile testing machine and samples were clamped on four sides using M6 bolts. The clamping bolts for silk and UHMWPE samples were tightened to 10 Nm and para-aramid samples were tightened to 5 Nm (in order to prevent the cutting of yarns at the edge of the test area). The probe speed was set to 300 mm/min, as directed in the standard and a 10 kN load cell was used in the testing. Instances of yarn slippage through the mounting ring were noted and those results were omitted from the results (as directed in BS EN 9073-5:2008).

The ball burst strength from six samples from each set of excursions was recorded and the mean and 95% confidence intervals calculated. An analysis of variance test was applied to the results to determine if there was a significant difference between the different conditioning regimes and the NL baseline. Where results showed a significant difference a post hoc Tukey pairwise comparison was conducted to determine where the differences between each conditioning regime were using the “R” statistical software package version 2.15.2.

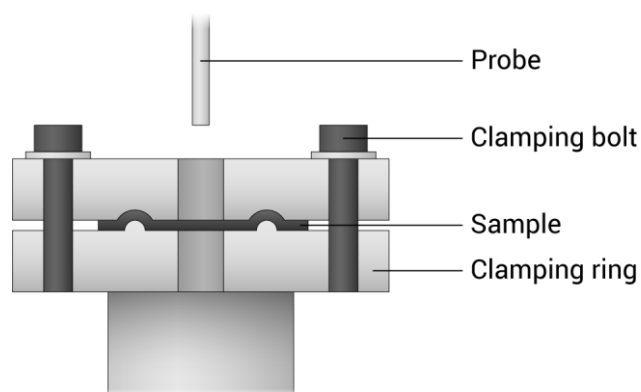

Figure 5-4 Experimental setup for the ball burst test (Copyright 2017, Cranfield University Media)

5.3.4 FTIR

Analysis of the surface chemistry of the fibres was conducted using FTIR analysis in the mid-infrared (MIR) range ($4,000\text{ cm}^{-1}$ to 400 cm^{-1} wave numbers) using Bruker Alpha FTIR, with Platinum ATR module and results analysed using Opus 7.2 (build 7,2,139,1294) software. As no treatments had been applied to the fibres and damage observed in Chapter 3 was to the surface of the fibres, it was determined

that this analysis was sufficient to highlight any changes in the chemical bonds of the fibres through laundering.

5.3.5 FESEM

Damage to the fabric samples was investigated using a JEOL 6700F field emission scanning electron microscope (FESEM; LEI detector, 3 kV, 8-17 mm working distance); samples were mounted on aluminium stubs with double sided carbon tape and sputter coated with gold palladium using Emitech K575X Peltier-cooled high resolution sputter coater. The typical images were taken from areas of the samples chosen to be more than 100 mm from any edge and not in an area disrupted by quilting or ballistic impact. Imaging was conducted at Otago University, New Zealand by a laboratory technician experienced in imaging fabrics.

Images were taken from samples cut approximately 10mm x 10mm from the fabric and chosen to be more than 100 mm from any edge and not in an area disrupted by quilting or ballistic impact. One sample was cut for each laundering regime. Images were taken at x35, x500 and x2000 magnifications. Measurements of the fibre thicknesses were taken, but results were inconclusive due to high variance in measured fibre diameter.

For the purposes of this study the descriptions of damage to the fibres are described in Table 5-2.

Table 5-2 Visual Assessment of Damage from FESEM Imagery

Description
No change.
Lengthwise splitting of fibres
Localised separation of the fibrils within the fibres
Surface breakage of fibrils / peeling
Pills begin to form
Complete fibre break

5.4 Results

5.4.1 Ballistic testing

The effect of laundering (L), tumbling only (T) and washing only (W) on the ballistic protective performance of the three fabric types is summarised in Table 5-3. The V_{50} data is normalised to the non-laundered (NL) panels to enable comparison among the different excursions.

Table 5-3 Summary of ballistic performance compared to baseline

	Silk			UHMWPE			Para-aramid		
	Change in V_{50} (%)	SE (%)	p value	Change in V_{50} (%)	SE (%)	p value	Change in V_{50} (%)	SE (%)	p value
NL	100.0	4.0	-	100.0	4.6	-	100.0	5.3	-
L	102.4	3.9	> 0.05 NL	97.8	3.3	> 0.05 NL	113.3	4.3	> 0.05 NL
T	95.6	4.6	> 0.05 NL > 0.05 L	100.1	4.8	> 0.05 NL > 0.05 L	121.3	4.5	< 0.05 NL < 0.01 L
W	100.7	6.7	> 0.05 NL > 0.05 L > 0.05 T	110.9	6.9	< 0.05 NL < 0.01 L > 0.05 T	116.5	12.5	< 0.05 NL < 0.01 L > 0.05 T

There was no evidence of a significant difference in the ballistic performance among the different excursions (NL compared to L, T and W) for the silk panels ($p > 0.05$).

There was no evidence of change in ballistic performance between the L or T conditioning compared to the NL for the UHMWPE panels. The performance between the NL and W panels showed evidence of a significant difference ($p \leq 0.05$) for the UHMWPE fabric. For the para-aramid fabric there was no evidence of a difference in performance between the NL and L conditions ($p > 0.05$), but there was evidence of a difference in performance between the T and the W panels in comparison with NL panels ($p \leq 0.05$ in both instances).

These results showed that the performance of the para-aramid fabric could be improved through conditioning. This may have implications for the construction of future fragment protective garments as performance may be improved with

laundering para-aramid fabrics. There was no evidence to suggest that laundering of the silk and UHMWPE fabrics affected their ballistic protective properties.

5.4.2 Change in dimension, thickness and mass per unit area

The change in dimensions of the panels in the X direction is presented in Table 5-4, in the Y direction in Table 5-5 and in panel thickness in Table 5-6. All three conditioning regimes had a measurable effect on the length and width of the panels. The UHMWPE samples were the most severely affected, though there were no clear differences between the L, T and W conditions. This implied that the felted UHMWPE was susceptible to shrinking, requiring mitigating possibly by quilting the UHMWPE fabric into the clothing. The silk sample panels that were tumbled only showed a change in dimension, without a corresponding increase in panel thickness. These changes were not reflected in the change in mass per unit area, suggesting the shrinkage of the panels was due to the shrinking of the poly-cotton fabric covers, rather than a change in the silk fabric.

Table 5-4 Dimensional change in panels in X direction

	Silk			UHMWPE			Para-aramid		
	Change in X (%)	SE (%)	p value (F _{3,20} = 57.1)	Change in X (%)	SE (%)	p value (F _{3,20} = 167.7)	Change in X (%)	SE (%)	p value (F _{3,20} = 23.1)
NL	100.0	0.4	-	100.0	0.3	-	100.0	0.3	-
L	96.0	0.2	< 0.01 NL	88.5	0.6	< 0.01 NL	964.0	0.2	< 0.01 NL
T	96.5	0.3	< 0.01 NL > 0.05 L	92.0	0.7	< 0.01 NL < 0.01 L	97.0	0.3	< 0.01 NL > 0.05 L
W	94.5	0.7	< 0.01 NL < 0.01 L < 0.01 T	88.0	0.6	< 0.01 NL > 0.05 L < 0.01 T	97.5	0.4	< 0.01 NL > 0.05 L > 0.05 T

Table 5-5 Dimensional change in panels in Y direction

	Silk			UHMWPE			Para-aramid		
	Change in Y (%)	SE (%)	p value (F _{3,20} = 15.2)	Change in Y (%)	SE (%)	p value (F _{3,20} = 186.2)	Change in Y (%)	SE (%)	p value (F _{3,20} = 41.8)
NL	100.0	0.4	-	100.0	0.3	-	100.0	0.1	-
L	95.0	0.3	< 0.01 NL	88.5	0.6	< 0.01 NL	964.0	0.1	< 0.01 NL
T	96.0	0.3	< 0.01 NL > 0.05 L	92.0	0.5	< 0.01 NL < 0.01 L	98.0	0.4	< 0.01 NL > 0.05 L
W	96.5	0.3	< 0.01 NL > 0.05 L > 0.05 T	86.0	0.7	< 0.01 NL < 0.01 L < 0.01 T	97.5	0.2	< 0.01 NL > 0.05 L < 0.01 T

Table 5-6 Dimensional change in panel thickness

	Silk			UHMWPE			Para-aramid		
	Pack Thickness (%)	SE (%)	p value (F _{3,20} = 200.5)	Pack Thickness (%)	SE (%)	p value (F _{3,20} = 28.4)	Pack Thickness (%)	SE (%)	p value (F _{3,20} = 4.7)
NL	100.0	1.0	-	100.0	3.0	-	100.0	2.6	-
L	124.5	1.5	< 0.01 NL	136.5	4.2	< 0.01 NL	115.5	1.7	> 0.05 NL
T	103.5	2.7	< 0.01 NL < 0.01 L	132.0	5.0	< 0.01 NL > 0.05 L	109.5	5.0	> 0.05 NL > 0.05 L
W	120.5	0.9	< 0.01 NL > 0.05 L < 0.01 T	131.0	3.6	< 0.01 NL > 0.05 L > 0.05 T	125.0	6.4	< 0.01 NL > 0.05 L > 0.05 T

The change in mass per unit area for the three fabrics was measured to BS EN 12127:1998 and the results presented in Table 5-7 below. The change in thickness of the fabrics for each excursion was measured in accordance with BS EN 5084:1997 (Table 5-8).

Table 5-7 Change in mass per unit area of fabrics for each condition

	Silk			UHMWPE			Para-aramid		
	Mass per unit area (%)	SE (%)	p value (F _{3,28} = 72.2)	Mass per unit area (%)	SE (%)	p value (F _{3,28} = 21.8)	Mass per unit area (%)	SE (%)	p value (F _{3,28} = 225.2)
NL	100.0	1.1	-	100.0	2.3	-	100.0	0.2	-
L	118.4	1.1	< 0.01 NL	131.4	5.8	< 0.01 NL	103.9	0.1	< 0.01 NL
T	100.1	0.6	> 0.05 NL < 0.01 L	123.8	2.8	< 0.01 NL > 0.05 L	101.7	0.1	< 0.01 NL < 0.01 L
W	107.1	1.2	< 0.01 NL < 0.01 L < 0.01 T	147.4	5.0	< 0.01 NL > 0.05 L < 0.01 T	105.9	0.2	< 0.01 NL < 0.01 L < 0.01 T

Table 5-8 Change in thickness of fabrics for each condition

	Silk			UHMWPE			Para-aramid		
	Fabric Thickness (%)	SE (%)	<i>p</i> value (F _{3,92} = 386.2)	Fabric Thickness (%)	SE (%)	<i>p</i> value (F _{3,92} = 25.2)	Fabric Thickness (%)	SE (%)	<i>p</i> value (F _{3,92} = 191.0)
NL	100.0	0.6	-	100.0	2.8	-	100.0	0.4	-
L	121.9	0.5	< 0.01 NL	127.7	3.6	< 0.01 NL	126.6	1.5	< 0.01 NL
T	101.4	0.7	> 0.05 NL < 0.01 L	118.6	2.4	< 0.01 NL > 0.05 L	110.6	0.7	< 0.01 NL < 0.01 L
W	124.1	0.8	< 0.01 NL > 0.05 L < 0.01 T	135.4	3.3	< 0.01 NL > 0.05 L < 0.01 T	132.8	1.3	< 0.01 NL < 0.01 L < 0.01 T

For the silk fabric there was a significant difference between the L and W conditioning regimes compared to NL samples for both the mass per unit area ($F_{3, 28} = 72.2, p \leq 0.01$) and the thickness ($F_{3, 92} = 386.2, p \leq 0.01$). There was no evidence of a difference between the NL and T conditions for either the mass per unit area ($F_{3, 28} = 72.2, p > 0.05$) or thickness ($F_{3, 92} = 386.2, p > 0.05$). There was evidence of a difference in the mass per unit area between the L and W conditions ($p \leq 0.01$), but no evidence of a difference in the thickness between the two conditions ($p > 0.05$). The mass per unit area and thickness of the silk fabric was more severely affected by the L and W conditioning than the T conditioning.

The UHMWPE fabric showed a significant difference in the mass per unit area ($F_{3, 28} = 21.8, p \leq 0.01$) and the thickness ($F_{3, 92} = 25.2, p \leq 0.01$) between the NL condition and the L, W and T conditions. There was no evidence of a significant difference

between the L and the W conditions for either the mass per unit area or thickness ($p > 0.05$ in both instances). There was evidence of a significant difference between the W and T conditions for both the mass per unit area and the thickness (p value ≤ 0.01 for both properties). The mass per unit area of the UHMWPE fabric was more affected by W conditioning than the T conditioning ($p \leq 0.01$). There was insufficient evidence to prove that the L conditioning had a greater effect than the T conditioning ($p > 0.05$ for both properties).

The mass per unit area and the thickness for the para-aramid were affected by the conditioning regimes ($F_{3, 28} = 225.2$ for mass per unit area and $F_{3, 92} = 191.0$ for thickness). There was a significant difference between each of the L, W and T conditions compared to the NL ($p \leq 0.01$ in all cases). There was also a significant difference between the L and W, L and T, and W and T conditions ($p \leq 0.01$ in all cases). The data shows that for para-aramid L and W conditioning had a greater effect on the fabric than the T conditioning and the W conditioning had a greater effect on the para-aramid than the L condition.

5.4.3 Modified ball burst strength results

The results for the ball burst strength are presented in Table 5-9.

The ball burst strength of the silk fabric was significantly affected by L and W conditioning compared to NL ($F_{3, 20} = 7.4$, p values ≤ 0.01 in both cases), but there was no evidence of a change in ball burst strength after T conditioning compared to

NL ($p > 0.05$). There was no evidence of a difference between the L and W conditions ($p > 0.05$). There was evidence of difference between the T condition and both the L and W conditions ($p \leq 0.01$). This confirms that the ball burst strength of the silk was affected by the L and W conditioning, but not the T conditioning, but there was no evidence of a difference between L and W conditioning.

There was evidence of a change in the ball burst strength between the W condition and the NL and T conditions ($F_{3, 20} = 5.6$, $p \leq 0.01$ and $p \leq 0.05$ respectively) for the UHMWPE fabric. There was insufficient evidence of a difference in the ball burst strength for the L and T conditions compared to the NL baseline ($F_{3, 20} = 5.6$, $p > 0.05$). The increase in the ball burst strength showed a corresponding increase to the mass per unit area measured for the W condition. This confirmed that the W conditioning had a greater effect on the UHMWPE fabric than the T conditioning. Although the L conditioning also appeared to be affected, there was insufficient evidence to demonstrate that the change was significant.

The para-aramid fabric showed a significant drop in ball burst strength after the W conditioning in comparison with the NL, L and T conditioning ($F_{3, 20} = 12.3$, $p \leq 0.01$). There was no evidence of a change in ball burst strength among the NL, L or T conditions ($p > 0.05$ in each case).

Table 5-9 Modified ball burst strength test results for silk, UHMWPE and para-aramid

	Silk			UHMWPE			Para-aramid		
	Mean Ball Burst Strength (%)	SE (%)	<i>p</i> value (F _{3,20} = 7.4)	Mean Ball Burst Strength (%)	SE (%)	<i>p</i> value (F _{3,20} = 5.6)	Mean Ball Burst Strength (%)	SE (%)	<i>p</i> value (F _{3,20} = 12.3)
NL	100.0	5.9	-	100.0	10.1	-	100.0	5.5	-
L	77.7	3.1	<0.01 NL	118.1	7.0	>0.05 NL	99.3	5.0	>0.05 NL
T	96.6	4.5	>0.05 NL <0.05 L	110.6	5.9	>0.05 NL >0.05 L	100.6	2.5	>0.05 NL >0.05 L
W	78.4	3.2	<0.05 NL >0.05 L <0.05 T	145.7	9.4	<0.01 NL >0.05 L <0.05 T	65.9	5.8	<0.01 NL <0.01 L <0.01 T

5.4.4 FTIR

The results from the FTIR spectroscopy in the MIR range for the silk, UHMWPE and para-aramid fabrics showed that for each of the conditions there is no evidence of a change in the chemical bonds identified. Results from the spectroscopy can be found in APPENDIX C.

5.4.5 FESEM

FESEM images were produced in order to compare the levels of fabric and fibre damage from each excursion (Figure 5-5 to Figure 5-13). The appearance of the silk and para-aramid fabrics after T conditioning did not appear to be affected and very little difference was observed between this condition and the NL condition. The UHMWPE fibres showed damage in the form of localised swelling and longitudinal splitting from T conditioning. Samples that had been L and W were visibly degraded compared to NL, appearing bleached in colour (for silk and para-aramid). Minor

disruptions to the fabric of the silk and para-aramid were observed in L and W conditions. The surface yarns were visibly degraded on the top surface of the fabrics for both silk and para-aramid. The primary mechanism for degradation to the silk and para-aramid fibres was fibrillation (Hearle et al., 1998), where the surface of the fibres was peeled back and evidence of the fibrils starting to form pilling was seen for both the silk and the para-aramid samples. The UHMWPE fibres exhibited localised swelling of the fibres and longitudinal splitting.

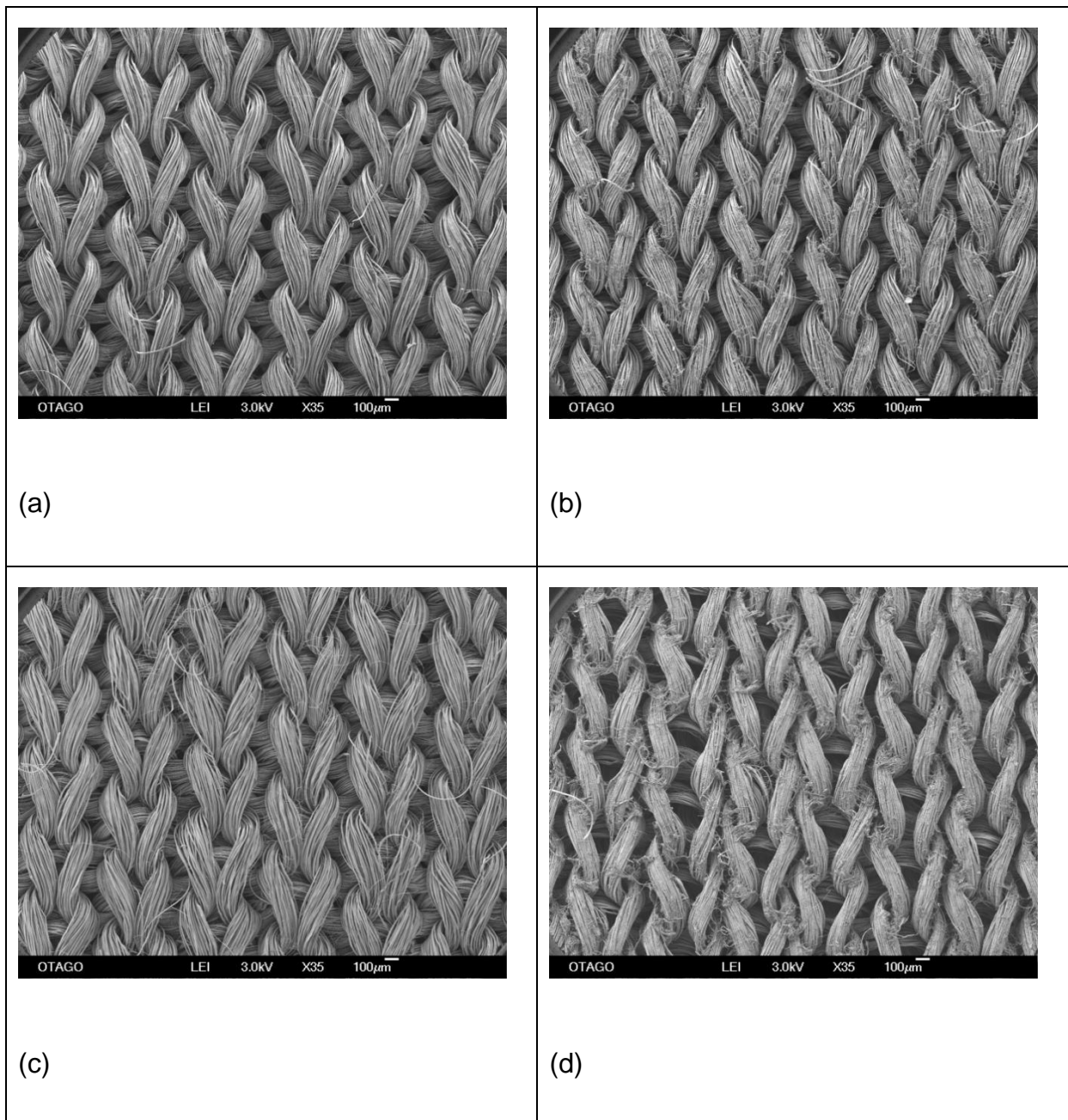

Figure 5-5 SEM Images (x35) silk not-laundered (a), laundered (b), tumbled only (c) and washed only (d)

In Figure 5-5 (b) and (d) both show breakage of surface fibrils with the formation of pills becoming evident in (d). There also appears to be greater disruption of the uniformity of the knitted structure in (d). By contrast there appears to be little difference in (a) and (c). The same trends are apparent in Figure 5-6 and Figure 5-7.

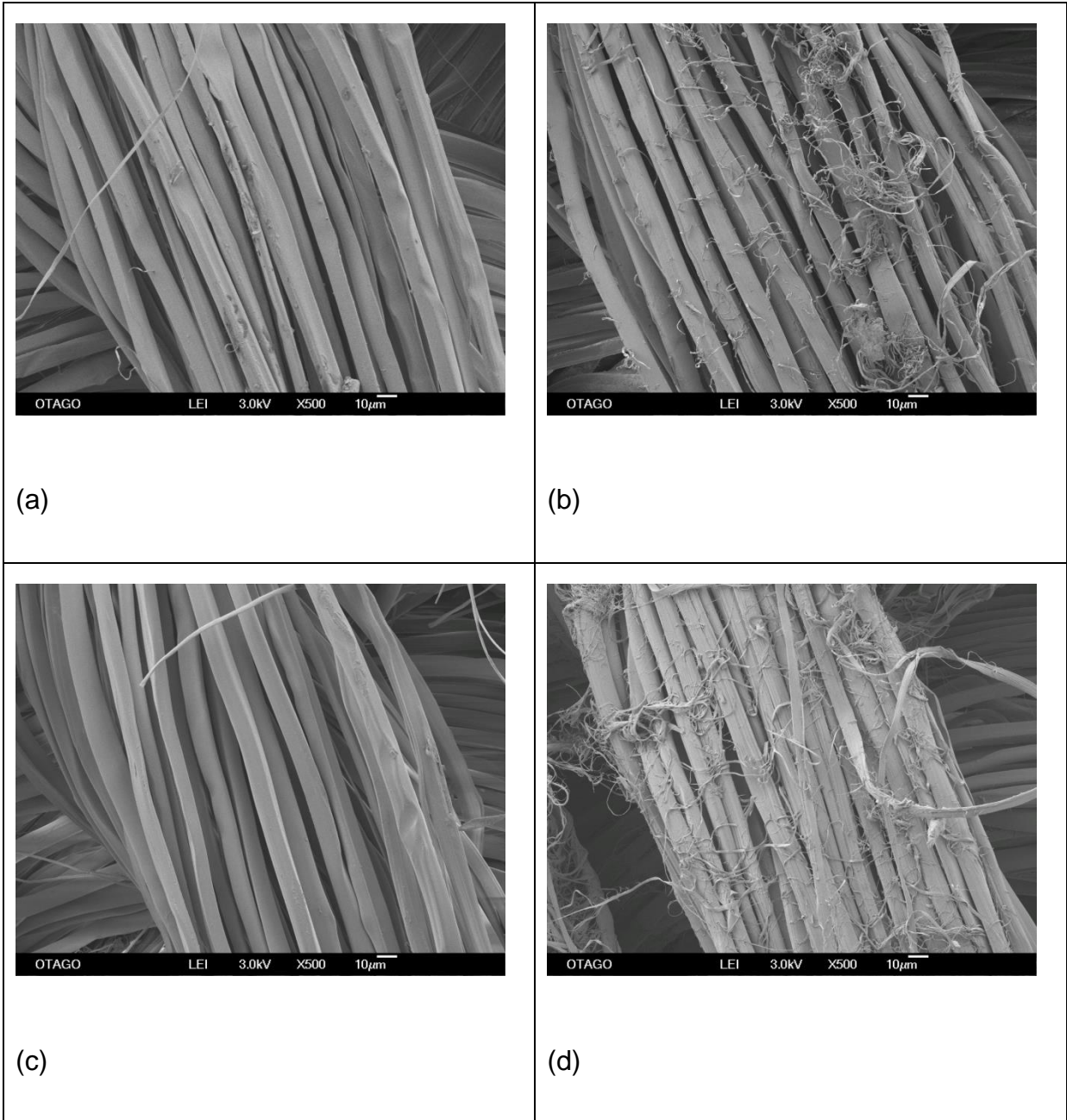

Figure 5-6 SEM Images (x500) silk not-laundered (a), laundered (b), tumbled only (c) and washed only (d)

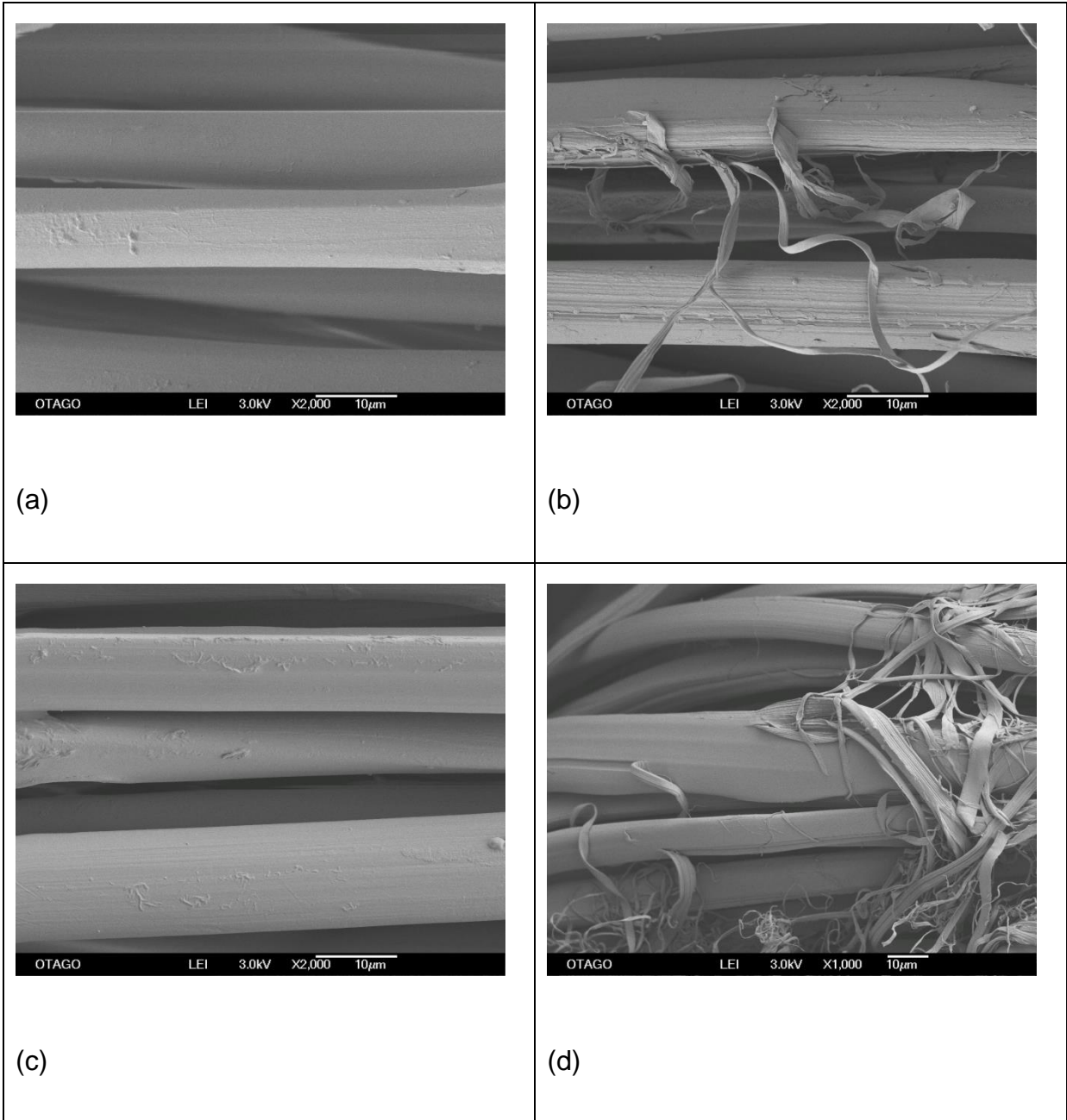

Figure 5-7 SEM Images (x2000) silk not-laundered (a), laundered (b), tumbled only (c) and washed only (d)

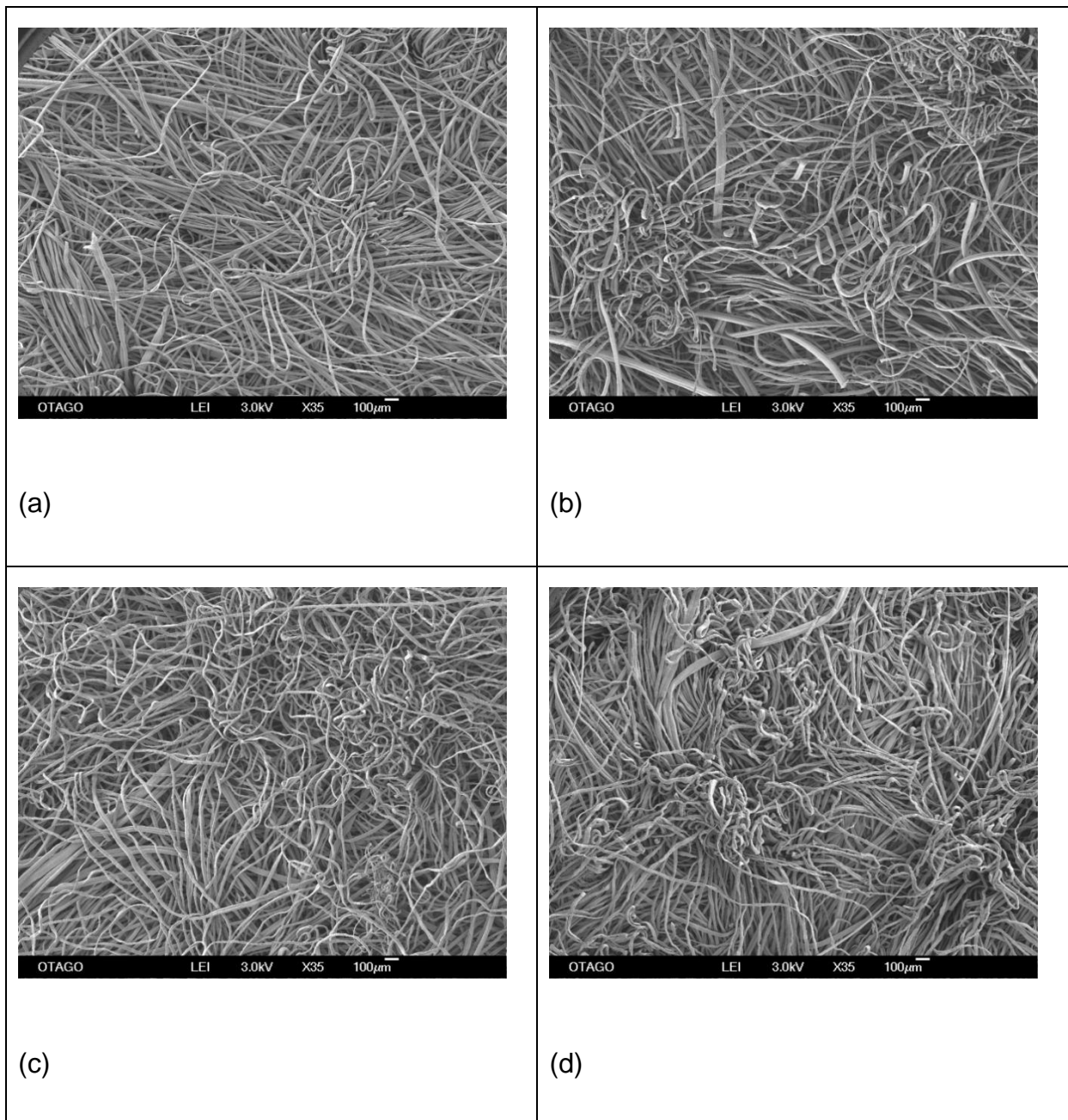

Figure 5-8 SEM Images (x35) UHMWPE felt not-laundered (a), laundered (b), tumbled only (c) and washed only (d)

From Figure 5-8 it is difficult to determine any trends between the four conditions. In Figure 5-9 and Figure 5-10 lengthwise splitting of the fibres is seen in all four conditions with the formation of localised separation of the fibrils within the fibre.

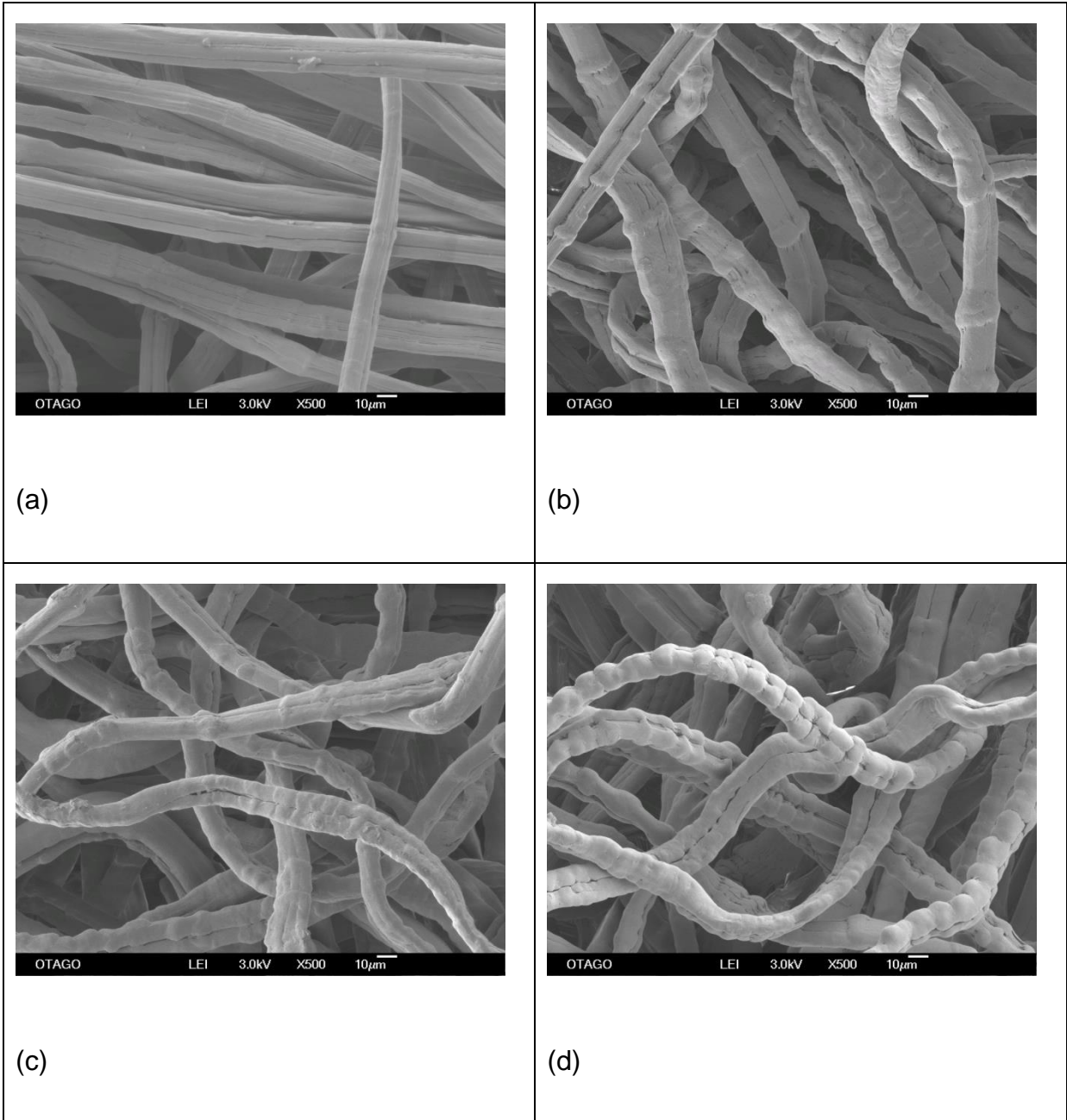

Figure 5-9 SEM Images (x500) UHMWPE felt not-laundered (a), laundered (b), tumbled only (c) and washed only (d)

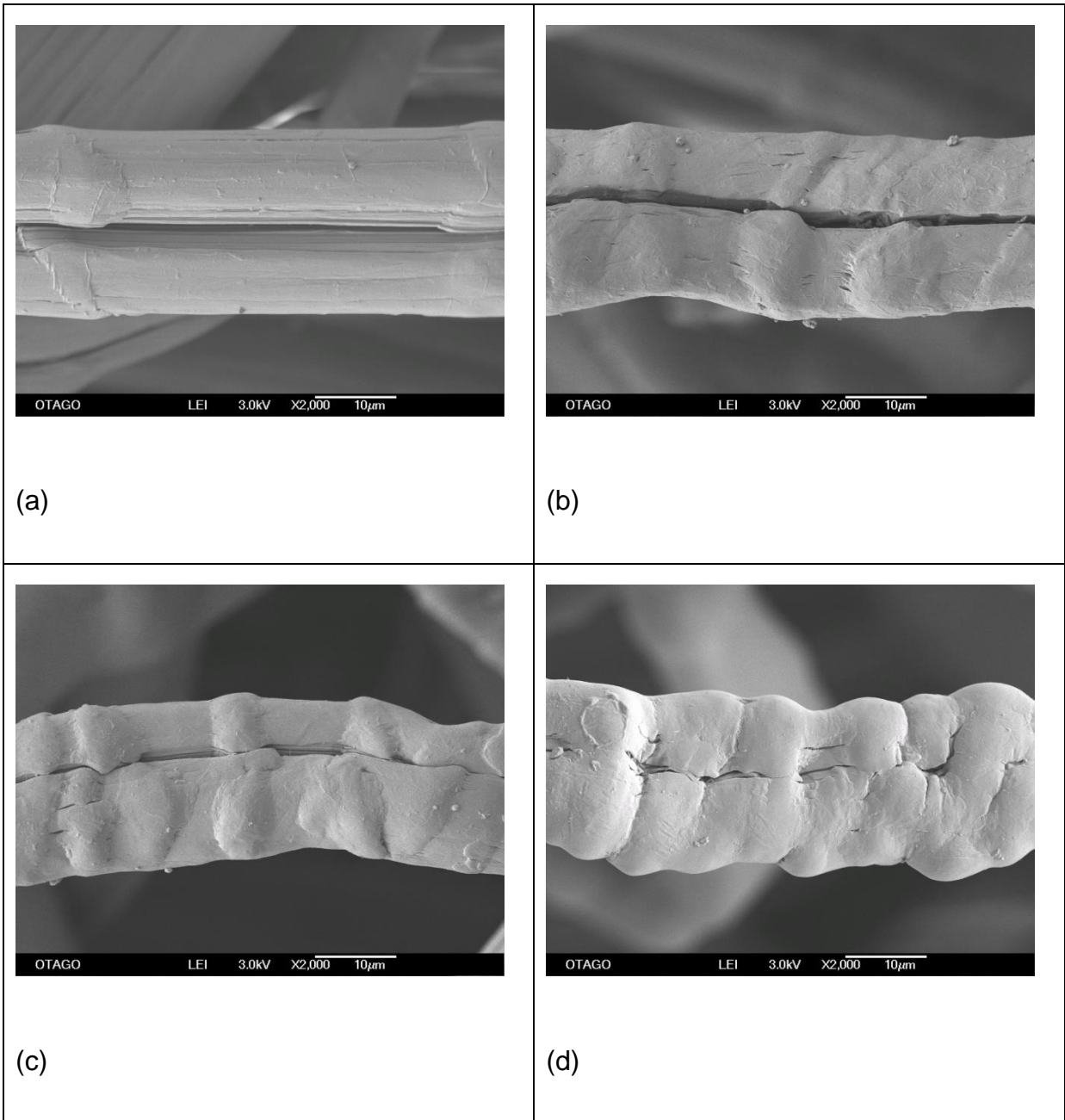

Figure 5-10 SEM Images (x2000) UHMWPE felt not-laundered (a), laundered (b), tumbled only (c) and washed only (d)

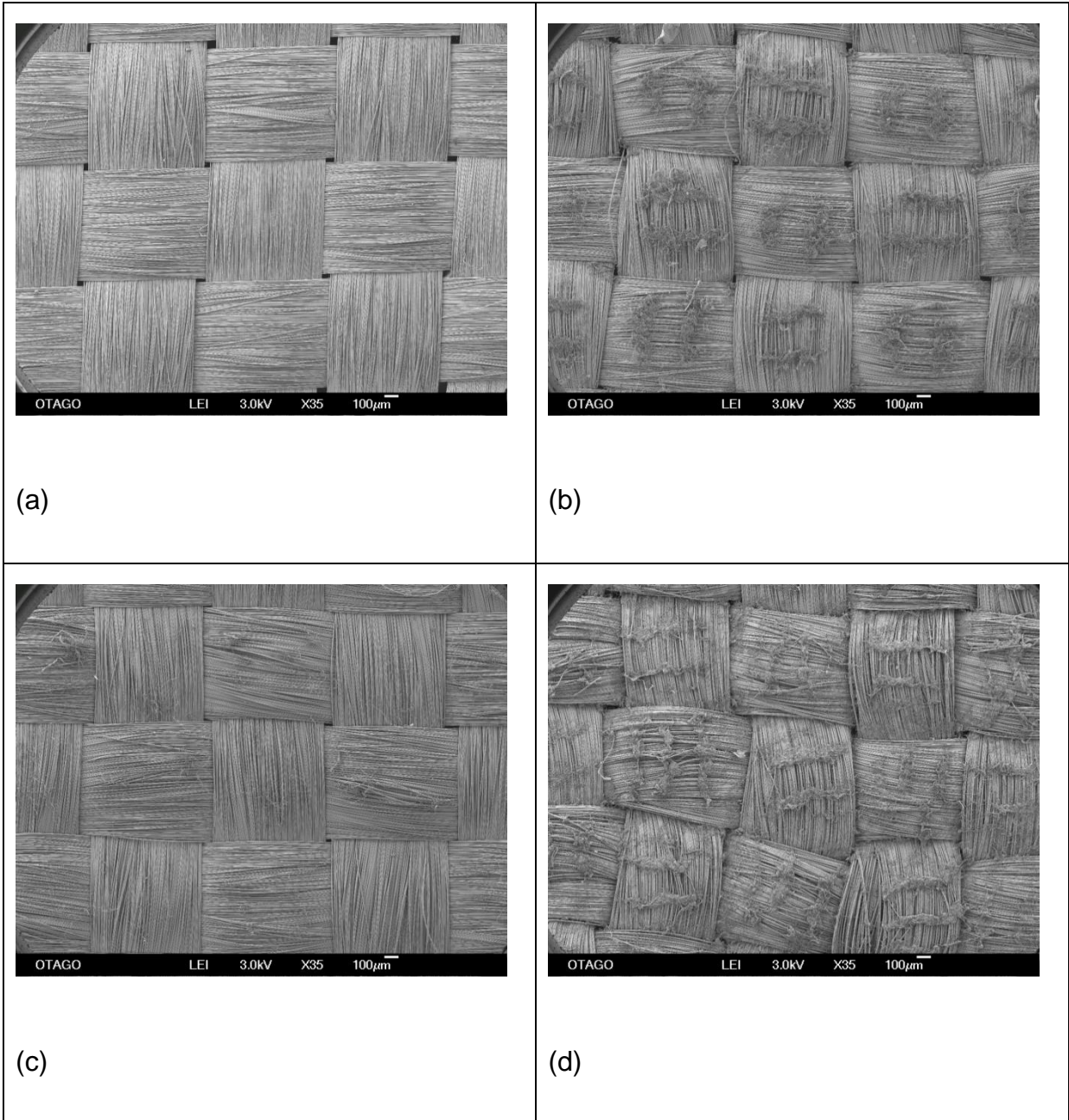

Figure 5-11 SEM Images (x35) woven para-aramid not-laundered (a), laundered (b), tumbled only (c) and washed only (d)

Image (c) in Figure 5-11 shows fabric with very similar appearance to image (a) (NL). There is no apparent disruption to the weave or evidence of fibrillation of the fibres. By contrast images (b) (L) and (d) (W) demonstrates fibrillation of the fibres with the

formation of pills on the surface. There is also apparent disruption to the uniformity of the weave.

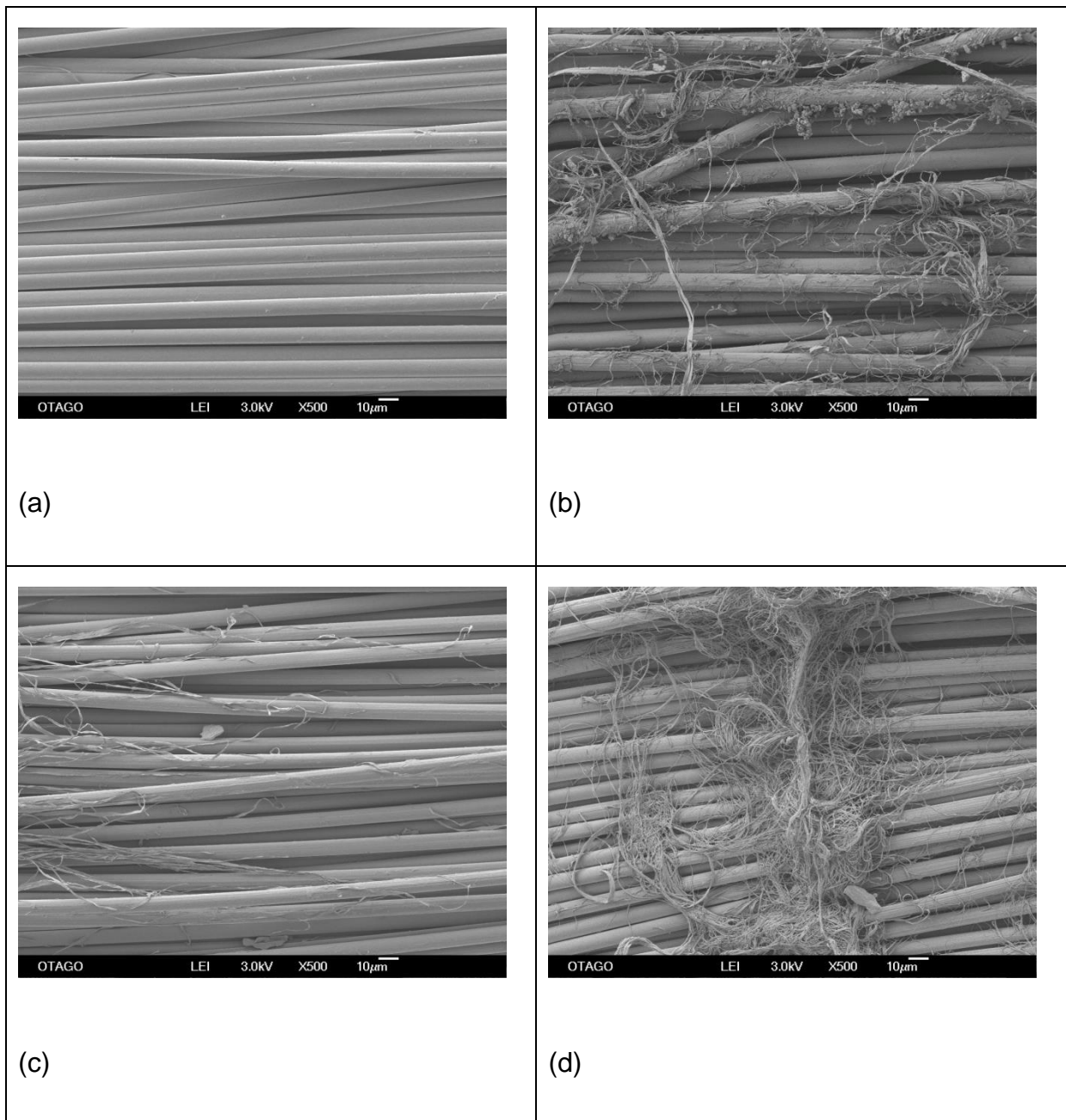

Figure 5-12 SEM Images (x500) woven para-aramid not-laundered (a), laundered (b), tumbled only (c) and washed only (d)

Figure 5-12 and Figure 5-13 show that at higher magnification the fibres from in panels in the L, W and T condition demonstrates levels of fibrillation.

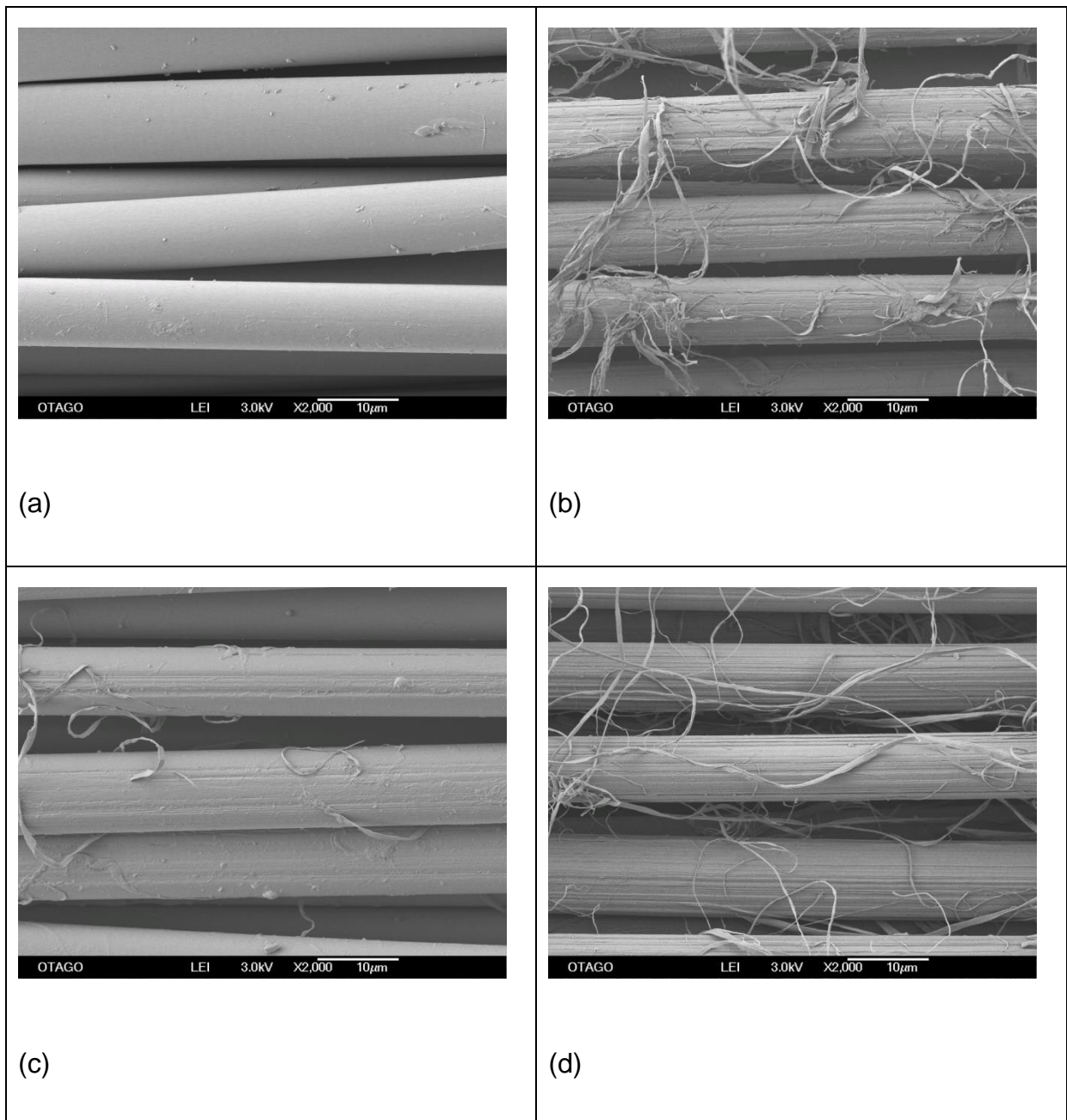

Figure 5-13 SEM Images (x2000) woven para-aramid not-laundered (a), laundered (b), tumbled only (c) and washed only (d)

5.5 Discussion

Laundering has been shown to affect the properties of the selected fabrics. During laundering the fabrics are exposed to water which imparts a temporary effect upon

the fibres. The effect on ballistic protective performance of para-aramid fabrics was shown to disappear when the fabrics were subsequently dried (Wilson, 1981, 1982).

It is known that the moisture content of fibres acts to increase their coefficient of friction (Howell et al., 1959, Morton et al., 1975, Bazhenov et al., 1999). This increase in friction in the silk and para-aramid fabrics during laundering resulted in increased abrasive damage to the surface of the fabrics. During laundering the layers of fabric in the sample panels were able to move across each other (albeit this was much reduced due to the quilting of the panels). The same interlayer movement of the fabrics would have been achieved when tumbling only, but without the presence of water, little abrasive damage was seen in these fabrics. The UHMWPE fabric showed damage to the fibres through localised swelling and longitudinal splitting after all three conditioning regimes (L, T and W). Although all three conditioning regimes altered the properties of the fabrics, the L and W conditioning regimes exhibited a more significant change due to the presence of water. This suggests that the presence of water during laundering contributed to an increase in the damage to the fibres, and damage was imparted to the fibres through flexing and rubbing of the fibres during the laundering. This trend was seen in the measurements of the dimensional change, mass per unit area and the thickness of the fabrics. A change was observed in all three conditioning regimes, with those exposed to water being more greatly affected.

A small increase in friction has been shown to improve the ballistic performance of plain woven fabrics (e.g. (Rao et al., 2009)). The increase in friction allows more energy to be dissipated by the fabric through the crossover of yarns in woven fabrics. If the friction is increased significantly the ballistic protective performance of the fabrics is decreased as the loading on the yarns increases too rapidly and tensile failure of the yarns occurs before energy is able to be transferred to secondary yarns (Bazhenov, 1997).

Knitted fabrics are less affected by increased inter-fibre / inter-yarn friction than plain woven fabrics, as there is less movement of fibres over each other during a ballistic impact. The fabrics rely on their ability to extend more during a low velocity ballistic impact (in the range of velocities used in this study). Little research has been published into the mechanisms by which knitted fabrics perform under a ballistic impact. This has primarily been as a result of knitted fabrics performing relatively poorly compared to their woven counterparts (Tobin, 1985, Greenwood et al., 1990). Knitted para-aramid for example was determined to offer poorer performance in a ballistic impact than its woven counterpart (Tobin, 1985, Greenwood et al., 1990). Work by Dalzell showed that a cause of this loss of performance was the use of staple fibres in knitted para-aramids, and when continuous fibres were used, the performance of the two fabric types were similar (Dalzell et al., 2013). This trend was

observed by Dalzell; with up to four plies of fabric, against different projectiles, both backed and unbacked with a block of gelatine.

Felted fabrics rely on the random alignment of the fibres during the initial impact of a projectile. Then more energy is dissipated from the projectile as the fibres slip over each other until either the dynamic tensile strength of the fabric is exceeded and the projectile passes through the fabric, or its energy has been fully dissipated by the fabric before complete failure of the fabric is achieved and the projectile arrested (Ipson et al., 1966, Hearle et al., 1971). In Chapter 3, it was seen that the ballistic performance of the para-aramid felt was improved by laundering, yet the UHMWPE felt remained unaffected. As it is unlikely that the surface friction of the UHMWPE would be affected by laundering process (the damage observed were along the length of the fibres without noticeable fibrillation), compared to the surface fibrillation seen in the para-aramid, little additional energy would be dissipated by the laundered UHMWPE during impact.

5.6 Conclusions

Damage to the fibres was characterised by fibrillation and peeling of the surface of fibres for the silk and para-aramid fabrics. The silk and para-aramid fabrics showed localised damage due to abrasion on the surface of the fabric after laundering.

Damage to the UHMWPE fibres was characterised by localised swelling of the fibres and longitudinal splitting.

The change in performance of the three fabrics investigated due to laundering is due to mechanical wear when the fabrics are wet. The water acted to increase the friction between the yarns and greatly enhanced the mechanical wear imparted to them. The degradation induced by mechanical tumbling in isolation is significantly less in all three fabrics investigated.

It can also be concluded that degradation through mechanical wear can be reduced if the fabrics are properly protected from water when in use. Preventing water from interacting with woven para-aramid and knitted silk fabrics may reduce the effect of mechanical wear and thereby increase the serviceable life of personal fragment protective garments.

5.7 Acknowledgments

The authors acknowledge the assistance of Mr Adrian Randall (DE&S) for information regarding the fabrics used in current clothing and providing some of the fabric used in this research.

5.8 References

- Arrieta, C., David, É., Dolez, P., et al. 2011. Hydrolytic and photochemical aging studies of a Kevlar®-PBI blend. *Polymer Degradation and Stability*, 96(8):1411-1419.
- Bazhenov, S. L. 1997. Dissipation of energy by bulletproof aramid fabric. *Journal of Material Science*, 32:4167-4173.
- Bazhenov, S. L. & Goncharuk, G. P. 2012. A study of yarn friction in aramid fabrics. *Polymer Science Series A*, 54(10):803-808.
- Bazhenov, S. L., Rozhkov, A. N., Kovalev, P. I., et al. 1999. Ballistic Tests of Aramid Armos and SVM Fabric Laminates. *Proceedings of the Novel Materials Workshop*. Cavendish Laboratory, Cambridge, UK: DERA.
- Bhatnagar, A. 2006. Lightweight ballistic composites - Military and law-enforcement application, Cambridge, England, Woodhead Publishing in materials.
- Bliss, C. I. 1934. The method of probits. *Science*, 79(2037):38-39.
- Breeze, J., Allanson-Bailey, L. C., Hepper, A. E., et al. 2015. Demonstrating the effectiveness of body armour: a pilot prospective computerised surface wound mapping trial performed at the Role 3 hospital in Afghanistan. *Journal of the Royal Army Medical Corps*, 161:36–41.
- Breeze, J., Allanson-Bailey, L. S., Hunt, N. C., et al. 2011. Mortality and morbidity from combat neck injury. *British Journal of Oral and Maxillofacial Surgery*, 49, Supplement 1(0):S23.

Breeze, J., Granger, C. J., Pearkes, T. D., et al. 2014. Ergonomic assessment of enhanced protection under body armour combat shirt neck collars. *Journal of the Royal Army Medical Corps*, 160(1):32-37.

Breeze, J., Helliker, M. & Carr, D. J. 2013a. An integrated approach towards future ballistic neck protection materials selection. *Proceedings of the Institution of Mechanical Engineers, Part H: Journal of Engineering in Medicine*, 227:581-587.

Breeze, J., Hunt, N., Gibb, I., et al. 2013b. Experimental penetration of fragment simulating projectiles into porcine tissues compared with simulants. *Journal of Forensic and Legal Medicine*, 20(4):296-299.

Breeze, J., Leason, J., Gibb, I., et al. 2013c. Characterisation of explosively propelled fragments injuring the neck. *British Journal of Oral and Maxillofacial Surgery*, 51:79-106.

British Standards Institute. BS 3870-1:1991 Stitches and seams part 1: classification and terminology of stitch types (ISO 4915:1991). 1991. BS 3870-1:1991.

British Standards Institute. BS EN ISO 5084:1997 Textiles - Determination of thickness of textiles and textile products 1997. BS EN ISO 5084:1997.

British Standards Institute. BS EN 12127 : 1998 Textiles - Fabrics - Determination of mass per unit area using small samples 1998. BS EN 12127 : 1998.

British Standards Institute. BS EN ISO 139:2005 Textiles - Standard atmospheres for conditioning and testing +A1:2011. 2005. BS EN ISO 139:2005.

British Standards Institute. BS EN ISO 5077:2008 Textiles - Determination of dimensional change in washing and drying. 2008a. BS EN ISO 5077:2008.

British Standards Institute. BS EN ISO 9073-5:2008 Textiles - Test methods for nonwovens Part 5: Determination of resistance to mechanical penetration (ball burst procedure) (ISO 9073-5:2008). 2008b. BS EN ISO 9073-5:2008.

British Standards Institute. BS EN ISO 3759:2011 Textiles - Preparation, marking and measuring of fabric specimens and garments in tests for determination of dimensional change 2011. BS EN ISO 3759:2011.

Dalzell, M. W., Long, L. R., Slusarski, K. A., et al. 2013. Ballistic Characterization of Fabrics for Groin and Extremity Protection, Including Continuous-Filament Knit Aramids. ARL-TR-6412. Army Research Laboratory. Aberdeen Proving Ground, MA, US.

Draper, N. R. & Smith, H. 1998. *Applied Regression Analysis*, New York, John Wiley & Sons Inc.

Duan, Y., Keefe, M., Bogetti, T. A., et al. 2005a. Modeling friction effects on the ballistic impact behavior of a single-ply high-strength fabric. *International Journal of Impact Engineering*, 31:996-1012.

Duan, Y., Keefe, M., Wetzel, E. D., et al. 2005b. Effects of friction on the ballistic performance of a high-strength fabric structure. *WIT Transactions on Engineering Sciences*, 49:219-229.

- Eisenhut, O. 1941. Zur Frage der Bestimmung des Schädigungswertes von Fasern, Garnen oder Geweben aus Zellulose und von Zellstoffen. *Melliand Textilber*, 22:424-426.
- Finney, D. J. 1971. *Probit Analysis*, Cambridge, Cambridge University Press.
- Firth, D. 1993. Bias reduction of maximum likelihood estimates. *Biometrika*, 80:27-38.
- Fisher, R. A. 1935. Appendix to Bliss (1935). *Annals of Applied Biology*, 22(4):164-165.
- Greenwood, K., Cork, C. R. & Downes, L. 1990. Ballistic Penetration of Textile Fabrics - Phase V. Contract Number 2044/156 CDE/SC. Manchester University. Manchester, UK.
- Hearle, J. W. S., Leech, C., Adayefa, A., et al. 1981. Ballistic Impact Resistance of Multi-Layer Textile Fabrics. DAJA 37-79-C-0532. University of Manchester. Manchester, UK.
- Hearle, J. W. S., Lomas, B. & Cooke, W. D. 1998. *Atlas of Fibre Fracture and Damage to Textiles (2nd Edition)*, Woodhead Publishing.
- Hearle, J. W. S. & Purdy, A. T. 1971. Research on energy absorption by nonwoven fabrics. DAJA-A37-71-C-0554. University of Manchester. Manchester, UK.
- Helliker, M., Carr, D., Lankester, C., et al. 2014. Effect of domestic laundering on the fragment protective performance of fabrics used in personal protection. *Textile Research Journal*, 84(12):1298-1306.

- Helliker, M., Carr, D. J., Lankester, C., et al. 2012. Effect of laundering on the fragment protective performance of single jersey knit silk used in personal protection. *Personal Armour Systems Symposium*. Nuremburg, Germany.
- Hördler, J., Mizner, F. & Hetzer, R. 1976. Veränderung der Reissfestigkeit, des DP-Grades und des Schädigungs faktors nach mehrmaligem Waschen van Textilien. *Melliand Textilberichte*, 10:853.
- Howell, H. G., Mieszkis, K. W. & Tabor, D. 1959. *Friction in textiles*, Butterworths Scientific Publications.
- Ipson, T. W. & Wittrock, W. P. 1966. Response of non-woven synthetic fiber textiles to ballistic impact. Technical Report 67-8-CM. Denver Research Institute. Denver, Colorado, US.
- Kosmidis, I. 2007. *brglm: Bias reduction in binary-response GLMs* [Online]. Available: <http://go.warwick.ac.uk/kosmidis/software>.
- Lewis, E. A., Pigott, M. A., Randall, A., et al. 2013. The development and introduction of ballistic protection of the external genitalia and perineum. *Journal of the Royal Army Medical Corps*, 159(Supp I):i15-i17.
- Li, Y., Li, C., Zheng, J., et al. 2015. Effects of water on the ballistic performance of para-aramid fabrics: three different projectiles. *Textile Research Journal*, 86(13):1372–1384.
- Lyons, J. W., Monego, C. J., Balas, F. F., et al. 1956. Improvement of the protective properties of nylon armor fabrics through finishing treatments. Headquarters Quartermaster Research & Development Command. Natick, Massachusetts.

- McCullagh, P. & Nelder, J. A. 1989. *Generalized Linear Models*, London, Chapman and Hall.
- Ministry of Defence. UK/SC/5449 Ballistic test method for personal armours and lightweight materials. 1994.
- Morrison, C. E. 1984. The mechanical response of an aramid textile yarn to ballistic impact. PhD, University of Surrey.
- Morrison, C. E. & Bowyer, W. H. 1978. Factors affecting ballistic impact resistance of Kevlar 49 reinforced composites. R762/1/August 1978. Fulmer Research Institute Limited.
- Morton, W. E. & Hearle, J. W. S. 1975. *Physical Properties of Textile Fibres*, London, England, The Textile Institute.
- Pinto, R., Carr, D. J., Helliker, M., et al. 2011. Degradation of military body armour due to wear: laboratory testing. *Textile Research Journal*, 82(11):1157-1163.
- R Core Team 2012. *R: A language and environment for statistical computing*, Vienna, R Foundation for Statistical Computing.
- Ramasamy, A., Harrisson, S., Lasrado, I., et al. 2009a. A review of casualties during the Iraqi insurgency 2006: A British field hospital experience. *Injury*, 40(5):493-497.
- Ramasamy, A., Hill, A. M. & Clasper, J. C. 2014. Improvised Explosive Devices: Pathophysiology, Injury Profiles and Current Medical Management. *Journal of the Royal Army Medical Corps*, 155(4):265-272.

- Ramasamy, A., Hill, A. M., Hepper, A., et al. 2009b. Blast Mines: Physics, Injury Mechanisms And Vehicle Protection. *Journal of the Royal Army Medical Corps*, 155(4):258-264.
- Ramasamy, A., Hinsley, D. E., Edwards, D. S., et al. 2010. Skill sets and competencies for the modern military surgeon: Lessons from UK military operations in Southern Afghanistan. *Injury*, 41(5):453-459.
- Rao, M. P., Duan, Y., Keefe, M., et al. 2009. Modeling the effects of yarn material properties and friction on the ballistic impact of a plain-weave fabric. *Composite Structures*, 89(4):556-566.
- Sakaguchi, S. M., Carr, D. J., Horsfall, I., et al. 2009. Protecting the extremities of military personnel: fragment protective performance of one- and two-layer ensembles. *Textile Research Journal*, 82(12):1295-1303.
- Sharma, D. M., Webster, C. E., Kirkman-Brown, J., et al. 2013. Blast injury to the perineum. *Journal of the Royal Army Medical Corps*, 159(suppl 1):i1-i3.
- Slater, K. 1991. *Textile degradation*, The Textile Institute.
- Stores and Clothing Research and Development Establishment. 1993. Fragment Simulating Projectile. A3/6723/3. Ministry of Defence.
- Tobin, L. B. 1985. Ballistic performance of woven knitted and felted materials against fragment simulators. SCRDE-Technical-Memorandum-85-3. Stores and Clothing Research and Development Establishment.
- Tobin, L. B. & Iremonger, M. J. 2006. *Modern Body Armour and Helmets*, Red Hill, Australia, Argos Press.

- Van Amber, R. R., Niven, B. E. & Wilson, C. A. 2010. Effects of Laundering and Water Temperature on the Properties of Silk and Silk-blend Knitted Fabrics. *Textile Research Journal*, 80(15):1557-1568.
- Wang, H., Xie, H., Hu, Z., et al. 2012. The influence of UV radiation and moisture on the mechanical properties and micro-structure of single Kevlar fibre using optical methods. *Polymer Degradation and Stability*, 97(9):1755-1761.
- Wilson, K. 1981. The ballistic performance of repellent Kevlar fabrics against fragment simulators. SCRDE/81/11. Stores and Clothing Research and Development Establishment. Colchester.
- Wilson, K. 1982. The water absorption of body armour materials and their ballistic performance against fragment simulators. SCRDE/81/16. Stores and Clothing Research and Development Establishment. Colchester.
- Zhang, H., Zhang, J., Chen, J., et al. 2006. Effects of solar UV irradiation on the tensile properties and structure of PPTA fiber. *Polymer Degradation and Stability*, 91(11):2761-2767.

6 DISCUSSION

6.1 Introduction

This chapter discusses the findings presented in the previous chapters and is divided into several sections:

- the mechanisms by which the three fabrics interacted with fragments;
- how laundering affected the three different fibre types;
- how laundering affected the three different fabric structures and hence the ballistic performance of the three fabrics;
- How laundering affected other fabric properties, such as dimensional change and ball burst strength.

It is important to distinguish among the effects of laundering upon the fibres/yarn and the effects on the fabric structure and the subsequent effects on fabric properties. In some instances the effect of laundering on the fibre/yarn did not translate into an effect on the ballistic protective performance of the fabric. For other fibres, the performance of the fibre dominated over the properties of the fabric.

6.2 Mechanisms by which fabrics stop fragments

In order to understand the effect of laundering on the ballistic protective properties of fabrics, it is important to understand the mechanisms by which a fabric stops a ballistic projectile. These mechanisms have only been reported in the latter half of the 20th Century. Initial research investigated the relative merits of a number of

fabrics utilising silk and nylon fibres for use in aircrew body armour (Sullivan, 1945). More recent work has considered the use of other fibres including para-aramid, polybenzobisoxazole (PBO) and ultra-high molecular weight polyethylene (UHMWPE) fibres (for example see (Gibb, 2005, Phillips, 2005)). These studies have investigated the merits of different fabric structures including various weaves, knits, felts and unidirectional fabrics. The choice of fibre and fabric structure has been in part determined by the desire to optimise the fabrics against defined threats and for specific applications (such for body armour or protection of vehicle occupants). Some fabric structures are particularly effective against certain types of threat, such as fragmentation, low velocity bullets or knife/spike. In this study the threat of interest was low velocity small fragments, represented by the 0.24g chisel nosed fragment simulating projectile (FSP) (Ministry of Defence, 1993).

Woven fabrics have demonstrated a wider versatility in stopping projectiles than felts, which were limited to lower areal density applications and knits, which tended to perform poorly against typical FSP used in armour testing (Dalzell et al., 2013). As a result most of the open literature focuses on the use of woven fabrics for ballistic protection applications.

6.2.1 Woven fabrics

Within a woven fabric, when a projectile strikes a yarn (which contains filament fibres) at normal incidence, it creates two waves; a longitudinal wave and a transverse wave e.g. (Roynance et al., 1973, Cunniff, 1992, Cheeseman et al., 2003).

The longitudinal wave will travel along the yarn at the speed of sound for that material, which is dictated by the stiffness and density of the material. The yarn will be pulled toward the impact point creating a tensile strain within the yarn. At the same time, a transverse wave is formed in front of the projectile along its path through the thickness of the fabric. The yarns directly engaged with the projectile are referred to as the primary yarns. As the two waves propagate through the fabric, they engage secondary yarns. This interaction is a function of the friction among the fibres in the yarns and among the yarns themselves and result in distortions in the structure of the fabric towards the impact point. This classic response of a woven fabric to a ballistic impact was observed in the current project. An example of ballistic impact into a two layered panel of woven para-aramid can be seen in Figure 6-1. The image is taken from high speed photography and clearly shows the propagation of both the longitudinal and transverse waves through the fabric.

In Figure 6-1 the longitudinal wave can be seen propagating in the vertical and horizontal planes, with a pyramid shaped cone forming in front of the projectile producing the transverse wave.

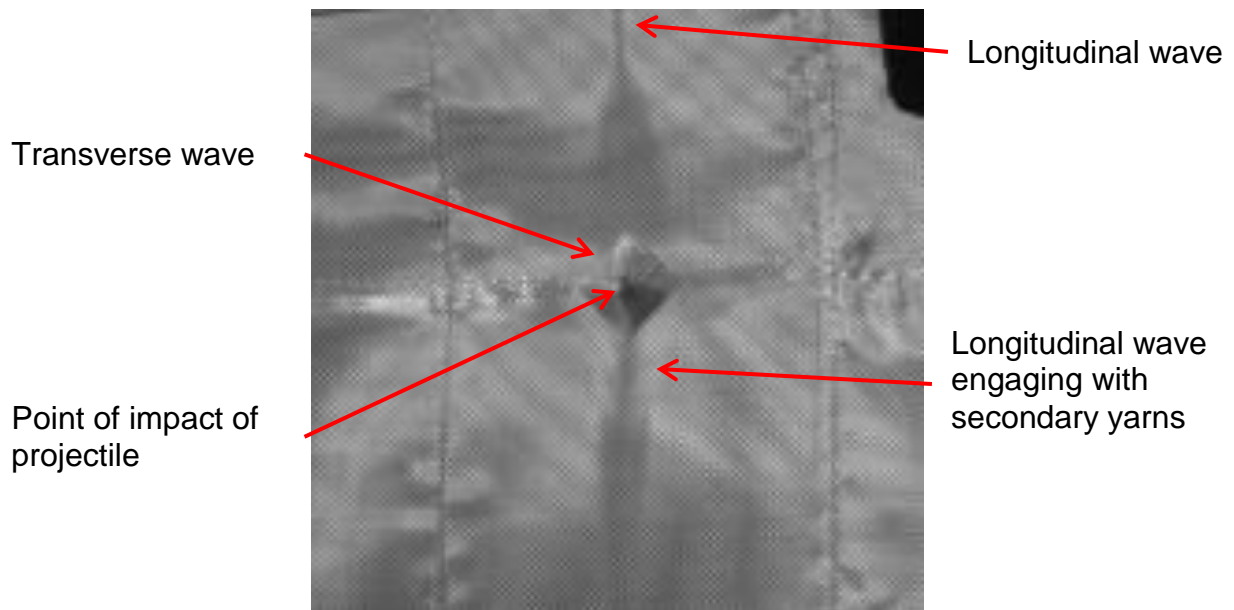

Figure 6-1 Example of ballistic impact of a 0.24 g chisel nosed FSP travelling at 237 m·s⁻¹ into woven para-aramid fabric (image from high speed video)

Studies had shown that the amount of energy dissipated from the projectile by the crossover of primary and secondary yarns is small compared to the energy dissipated by the primary yarns (Roylance, 1980). However, this analysis was later challenged, as the contribution of the crossovers between primary and secondary yarns was shown to provide a greater contribution to a fabric's ability to dissipate energy across the fabric (Ting et al., 1998, Morye et al., 2000).

If the tensile strain imparted on the primary yarns exceeds their strain at break, they will fail and the projectile will pass through that layer of fabric. Energy is transferred from the projectile to the fabric in several ways, through the elastic stretch of the fibres, the breaking of fibres and the gross movement of the fabric (Morye et al., 2000).

In an armour system comprising of multiple layers of fabric, yarns in the second and subsequent layers begin to be loaded before the transverse and longitudinal waves have propagated far in the first layer. This leads to a complex interaction among the layers, and results in the overall armour performance being less than the sum of the performance of the individual layers loaded in isolation (Cunniff, 1992). Fabrics made with fibres with low surface frictional properties will have reduced interaction with secondary yarns, and the primary yarns will be pulled out more easily by the projectile. Low friction between the yarns and the projectile will also reduce the fabric's ability to dissipate kinetic energy from the projectile and reduce its performance because the projectile can slip between the fibres and or yarns (Bazhenov, 1997). High friction between the yarns can result in increased loading on the secondary yarns, and inhibit the primary yarns ability to move in the ballistic impact. This increases the load rate on the primary yarns and leads to earlier failure of the yarns, thus reducing the fabrics performance (Bazhenov, 1997, Duan et al., 2005, Bazhenov et al., 2012).

Other studies reported that improvements in the performance of the fabrics could be obtained by scouring the fabrics and thus "reducing the slipperiness" of the yarns (Laible, 1980). Other research into the effect of altering the friction of fibres within a woven fabric by applying treatments, showed that the energy dissipated in the ballistic impact can be increased with increased friction (Hearle et al., 1982). It was

also noted though, that the application of a treatment to the fabric would increase the mass of the fibres and this would reduce the speed of the longitudinal wave, thus reducing the energy dissipated by the fabric. This has made studying the effect of altering the friction of the fibres within a fabric difficult, as the method of improving one set of properties has the effect to reduce a different set of properties, thus producing no net benefit. A balance has to be struck between yarn to yarn and yarn to projectile friction and how it is achieved. Too much or too little friction will reduce the performance of the fabrics, and may have a negative affect other desirable fabric properties.

6.2.2 Felted fabrics

Early research into the effectiveness of felts in ballistic protective applications identified that felts were superior to other fabric structures at low areal densities (Laible et al., 1969). As the projectile velocity increases, requiring higher areal densities, other fabrics begin to outperform felted fabrics (Laible et al., 1969).

The ability of a felted fabric to absorb energy from a projectile is related to its ability to move freely in the direction of the projectile due to fibre pull out from the bulk structure (Ipson et al., 1966, Hearle et al., 1971). The energy dissipated by the fabric greatly decreases when the velocity of the projectile is in excess of the ballistic limit of the fabric (Ipson et al., 1966).

In Figure 6-2 the impact of a 0.24g FSP into UHMWPE felted fabric is shown. Similarly to the woven fabric, the impact causes a longitudinal wave to emanate from the impact point. This longitudinal wave is faint and difficult to track in still photography, but is more evident in high speed imagery. In the example of felted fabrics, the wave travels radially outwards from the impact point, as the fibres within the felt are pulled towards the impact point. A cone forms as the transverse wave as the fabric is extended by the projectile along its path. Unlike the pyramid shaped cone seen in the woven fabric, an elliptical cone is formed as the fibres are not uniformly orientated (bi-directionally) within the felt. The act of pulling the fibres with the projectile is the predominant mechanism by which the felts absorb energy from the projectile.

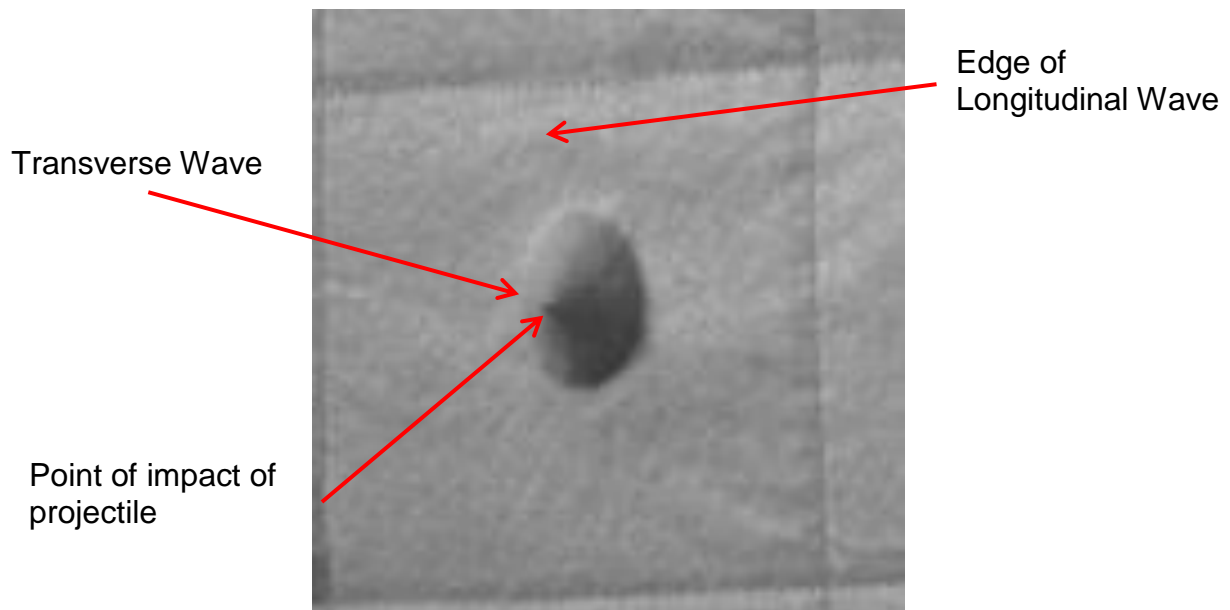

Figure 6-2 Example of ballistic impact of a 0.24 g chisel nosed FSP travelling at 298 m·s⁻¹ into felted UHMWPE fabric (image from high speed video)

6.2.3 Knitted fabrics

There is a paucity of published research into the performance of knitted fabrics during a ballistic impact. Early research identified that knitted fabrics performed poorly compared to woven fabrics made from the same fibres (Tobin, 1985, Greenwood et al., 1990), however it should be noted that these fabrics contained yarns manufactured using staple fibres. It was recently reported that knitted fabrics manufactured with para-aramid fibres were improved if continuous fibres instead of staple fibres were used (Dalzell et al., 2013). In all of these studies, the performance of relatively high areal density panels of knitted fabrics was assessed, against

relatively large and fast fragment simulating projectiles, typically the 1.1g chisel nosed FSP (Ministry of Defence, 1993).

In this study, the ballistic impacts on a knitted silk fabric were investigated adding to the knowledge of how knitted fabric reacted during an impact event. The performance of low areal density panels were investigated using small (0.24g) relatively slow fragment simulators¹⁷. This approach is in contrast to previous studies which typically focussed on larger (1.1g metallic) FSP travelling at higher velocities for body armour applications¹⁸. The low areal density fabric panels were chosen, as these were deemed suitable for clothing applications as averse to bespoke armour solutions such as body armour vests.

In the projectile velocity region investigated, the knitted silk fabrics performed to the same level as the woven fabric made from the modern high performing para-aramid fibre. This is due to the structure of the fabric more than the performance of the fibre itself. It is reasonable to expect that a fabric knitted from para-aramid would have performed significantly better than the identical knit made from silk. This is due to the extremely high strength of the para-aramid fibres compared to that of the silk fibres. In a knitted fabric, the ballistic protective performance is related to the ability of the fabric to extend before the localised loading on the yarns exceeds their tensile

¹⁷ The velocities were typically lower than the V_{50} velocities quoted for combat body armours currently fielded.

¹⁸ Typical V_{50} values for body armours are in excess of $450 \text{ m}\cdot\text{s}^{-1}$.

strength. Energy from the projectile is dissipated in the extension and movement of the fabric.

From Figure 6-3, the impact of the 0.24g FSP into the knitted silk fabric can be seen. The image is taken from high speed video. The edge of the longitudinal wave can be seen radiating outwards from the point of impact. The wave is travelling both along the individual yarns and is being transmitted across the courses of the knit as the yarns are pulled towards the impact point. The transverse wave forms a pyramid similar to the woven fabric, as the yarns are pulled towards the impact point along the path of the projectile.

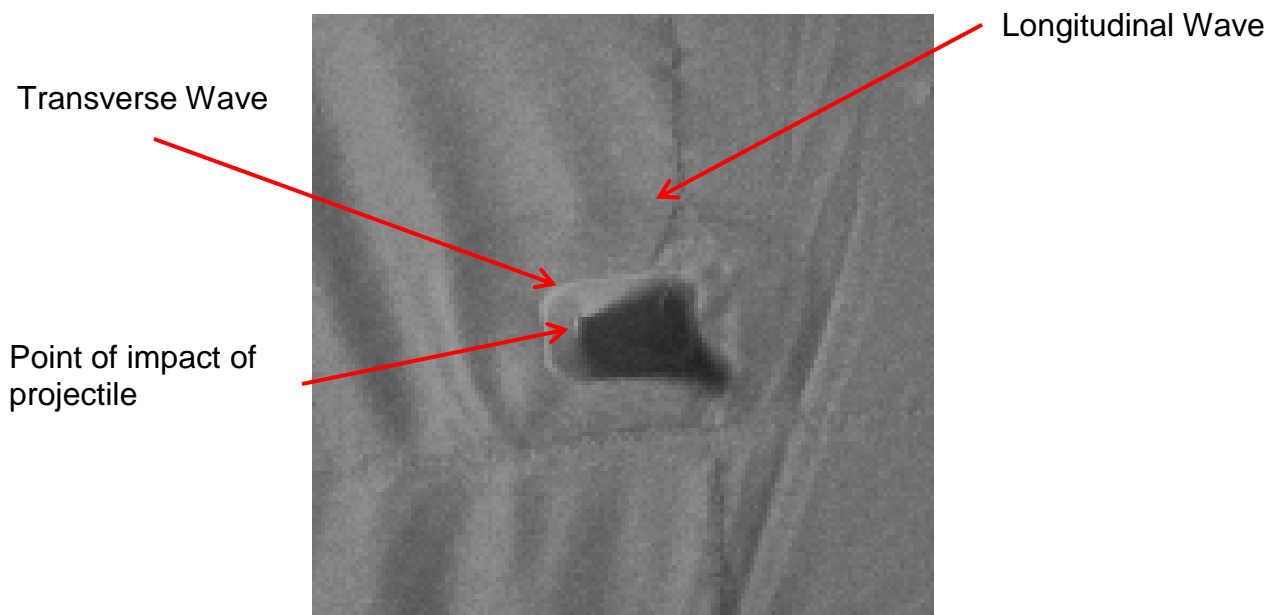

Figure 6-3 Example of ballistic impact of a 0.24 g chisel nosed FSP travelling at 228 m·s⁻¹ into knitted silk fabric (image from high speed video)

In summary, the mechanisms by which the three fabrics transfer energy from the projectile to the fabric differed significantly. Each fabric relies upon different balance between the properties of the fibre and the fabric structure in order to provide a protection from fragments. For woven fabrics the performance of the fibre appears to dominate over the fabric structure. In felted fabric, there is insufficient evidence to determine whether the fibre or fabric properties dominate. The knitted structure for the silk fabric dominated over the performance of the fibre in the context of this study. For larger, faster fragments the contribution of fibre/fabric structure performance may be different.

6.3 Effect of laundering on the fibres

In this section the effect of laundering on the properties of the fibres and fabrics used in this study are discussed. It is important to consider both the effect of laundering on the individual fibre properties as well as the bulk fabric properties, as the two may at first appear to be at odds.

6.3.1 Silk

The effect of laundering on silk fibres and fabrics has been reported in the open literature e.g. (Quaynor et al., 1999, Van Amber et al., 2010). The surface damage and fibrillation of the silk fibres reported in this study (see Figure 6-4) were identical to that reported in work in the open literature (Van Amber et al., 2010).

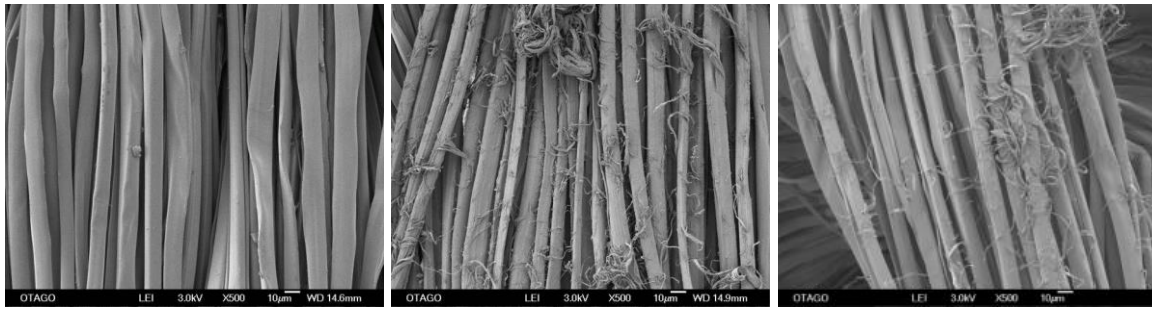

Figure 6-4 Example of degradation to silk fibres; not-laundered from Chapter 3 (left), laundered 27 cycles at 40 °C from Chapter 3 (Centre) and laundered 27 cycles at 40 °C from Chapter 4 (right)

Laundering of knitted silk fabric has been shown to stiffen the fibres, demonstrated by the retention of the crimp after laundering (Quaynor et al., 1999). The change in crimp implies a stiffening of fibres after drying, which would increase resistance to the slipping of fibres during a ballistic impact. It was not within the scope of these studies to assess the effect of laundering on the frictional properties of the fibres. This is possibly due to the reported subjectivity of measuring friction in fibres reported in the open literature (Morton et al., 2008).

Analysis conducted in Chapter 4 using FTIR Spectrometry failed to identify any changes in the bonds within the silk fibres as a result of laundering. This lack of an identifiable change and little recorded change in performance of the fibres suggested that the effects on the fibres is a mechanical one, rather than a chemical change.

6.3.2 UHMWPE

There is a dearth of information in the open literature on the effect of laundering on UHMWPE fibres. There are some reports of wear damage to high modulus polyethylene fibres exhibiting splitting along the length of the fibres, (Hearle et al., 1998). Damage to UHMWPE fibres from flex-fatigue was characterised as the development of axial splits in the filaments (Morton et al., 2008). Other work investigating the effect on UHMWPE fibres through weaving identified the formation of kink bands, similar to that shown in this study (Figure 6-5) (Hockenberger, 1998). These kink bands are similar to the localised swelling of the fibres and separation of the fibrils where bending has occurred. Otherwise, reported damage to UHMWPE fibres has been limited to damage incurred during a ballistic impact (Carr, 1999). In this work, the damage during a ballistic impact showed shear failure of the fibres at lower velocity impacts on single fibres and fibre melting was observed at higher impact energies (Carr, 1999).

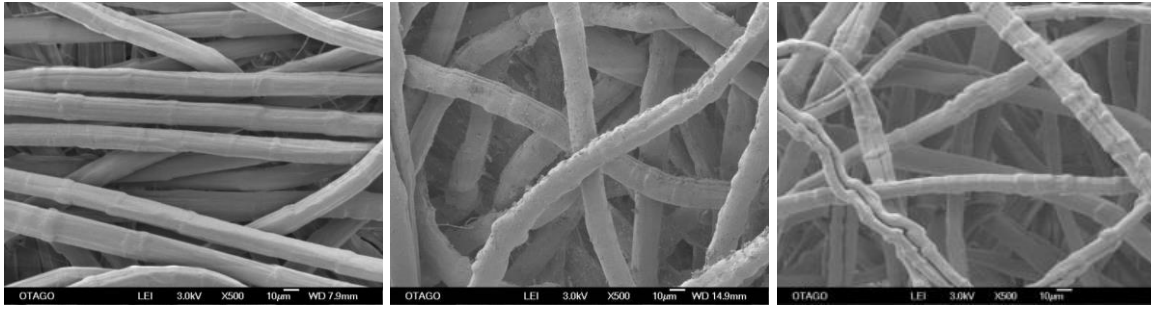

Figure 6-5 Example of degradation to UHMWPE fibres; not-laundered from Chapter 3 (left), laundered 27 cycles at 40 °C from Chapter 3 (Centre) and laundered 27 cycles at 40 °C from Chapter 4 (right)

In the current study, the damage to the UHMWPE fibres was characterised by a separation of the fibrils within the fibre at points where the fibres appeared to have been bent during the laundering process. The localised swelling of the fibres appeared to be related to an increase in the separation of the fibrils. This type of damage mechanism does not appear to have been reported in relation to laundering, with only reporting on the mechanical damage imparted to the fibres during weaving (Hockenberger, 1998).

From the FTIR Spectroscopy conducted in Chapter 4, no change in the bonds within the fibres was identified. This is supported by the ballistic results which also did not determine a change in the fragment protective performance of the fabrics.

6.3.3 Para-aramid

Early research into the effects of moisture on the ballistic protective performance of para-aramid identified a loss in performance of para-aramid fabrics when wet

(Wilson, 1982, Bazhenov, 1997, Gibb, 2005). As a result, the laundering of fabrics made from para-aramid was avoided as reported by Du Pont (DHB Armor Group, 2004). In this report by Du Pont into the effect of wear on their para-aramid fibres, it was noted that police body armours were not routinely laundered, leading to a number of issues with used armour relating to hygiene. Although there have been studies into the effect of wear on armours made from para-aramid fibres, no detailed analysis of the damage mechanisms to the fibres were reported (Withnall et al., 2010, Bourget et al., 2012). In this study the damage to the para-aramid fibres was characterised as surface peeling of the fibres and fibrillation. In Figure 6-6 para-aramid fibres in the not-laundered and two nominally identical laundered states from Chapter 3 and Chapter 4 are presented. It can be seen that the type of damage imparted to the fibres by laundering is similar in both instances. It should be noted that the fabric in Chapter 3 was loom state and the fabric in Chapter 4 was scoured by the manufacturer. It had been postulated that the increase in performance measured in the woven para-aramid from Chapter 3 was as a result of the removal of the size from the loom state fabric, but similar changes in fragment protective performance were observed in both fabrics, suggesting that this alone could not be the cause of the increase in performance as originally proposed.

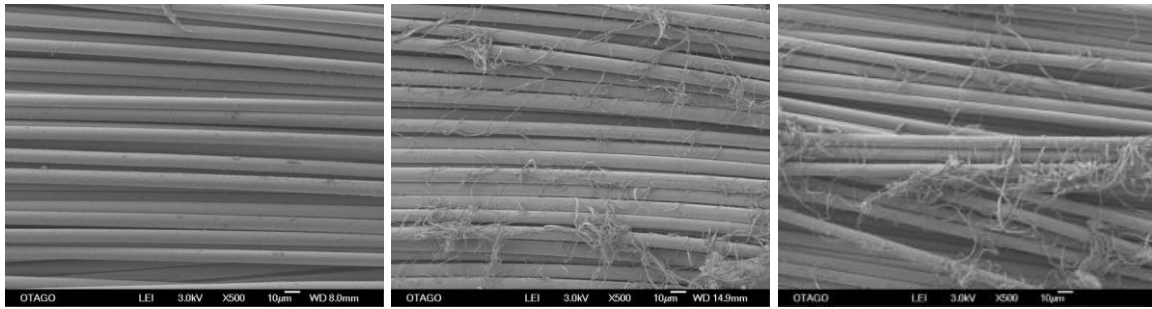

Figure 6-6 Example of degradation to para-aramid fibres; not-laundered from Chapter 3 (left), laundered 27 cycles at 40 °C from Chapter 3 (Centre) and laundered 27 cycles at 40 °C from Chapter 4 (right)

From results presented in Chapter 3 the performance of the para-aramid fibre dominated the performance of the fabric, irrespective of the fabric structure (felt or woven). This is emphasised by the change in performance of the two para-aramid fabrics investigated in Chapter 3 (summarised in Table 6-1). In both para-aramid fabrics a similar improvement in the performance was observed. By contrast, the UHMWPE felt showed no improvement in fragment protective performance after laundering. In these instances, the fibre properties dominated the performance of the fabrics. This assessment is supported by the reported performance of knitted para-aramid being improved by changing from staple to continuous fibre (Dalzell et al., 2013).

Table 6-1 Change in performance of woven and felted para-aramid fibres due to laundering (Chapter 3)

	Woven		Felted	
	V ₅₀ (%)	SE (%)	V ₅₀ (%)	SE (%)
Not-laundered	100	3	100	3
27 Washes	116	3	113	4

In Chapter 4, FTIR spectroscopy was conducted on the fibres and this failed to identify a change in the chemical bonds of the fibres. It is therefore unlikely that the changes in performance observed were as a result of a breakdown in the chemical structure of the fibres after laundering.

6.4 Effect of laundering on the mechanisms by which fabrics stop fragments

In this section, the effect of laundering on the three fabric structures separately to the effects on the individual fibre types is discussed. Section 6.3 demonstrated that the effect of laundering on fibres may not translate into an effect at the fabric level. For example, the silk fibres exhibited a very similar type and level of degradation to the para-aramid fibres (Section 3.4), but the change in surface friction of the silk did not impart a change in the fragment protective performance of the knitted fabric. In this

case the performance of the fabric structure had a greater influence than the performance of the individual fibres.

6.4.1 Woven fabrics

The effect of the presence of water in a woven fabric has been identified as a primarily factor in affecting the intra-yarn friction as well as yarn-projectile friction (Wilson, 1982, Bazhenov, 1997). The effect of moisture within a fabric on the friction between yarns in isolation of any mechanical wear, was shown to be temporary and was removed when the fabrics are subsequently dried (Wilson, 1982). Washing¹⁹ fabric has been shown to provide a net improvement in its ability to absorb energy from a projectile (Hearle et al., 1982). In the work of Hearle et al, the change in performance was attributed to the removal of residual size from the scoured fabric. Results from the current study suggest that this was not necessarily the case, and it may have been the as a result of degradation imparted due to mechanical wear in the washing process.

There is insufficient information in the work by Hearle et al on the method of washing to be able to determine if the change in performance observed was as a result of washing the fabric or from removal of residual size. In Chapter 5, the presence of water increased the mechanical wear on the fibres under investigation. The presence of the water in fabrics during the tumbling process of laundering imparted

¹⁹ The study by Hearle mentioned the effect of “washing” the fabric, but no detail of how this was achieved is made.

significant damage to the fabric. In comparison the fabric that was mechanically tumbled whilst dry showed very little damage to the fibres (Section 5.4.5). This damage acted to increase the intra-yarn friction within the fabric. Other studies have shown that laundering acts to increase the crimp of yarns within fabrics e.g. (Lund et al., 1959). The effect of crimp within woven fabrics has been shown to influence their performance during a ballistic impact e.g. (Shim et al., 1995, Ting et al., 1998, Tan et al., 2005).

In this study it has been shown that ballistic protective performance of the woven para-aramid can be improved through laundering. As the improvement in performance was caused by imparting degradation upon the para-aramid fibres, it would be expected that at some point the increase in performance will be reversed. Although none of the laundering regimes showed the performance to drop below the not-laundered condition, there is evidence that the performance of the fabrics was beginning to deteriorate. In Figure 6-7, the performance of the woven para-aramids is shown against the number of laundering cycles for the fabrics laundered at 40 °C and at 90 °C, with laundering up to 52 cycles and 45 cycles respectively. The error bars in Figure 6-7 are the 95% confidence intervals. The woven para-aramid shows improved performance for both laundering conditions up to 27 cycles. After 27 cycles a small but statistically insignificant drop in performance is observed to the 90 °C laundering. However, there is a significant drop in performance between the 27

cycles and the 52 cycles for the 40 °C laundering. This shows that the greatest improvement was observed before 45 cycles.

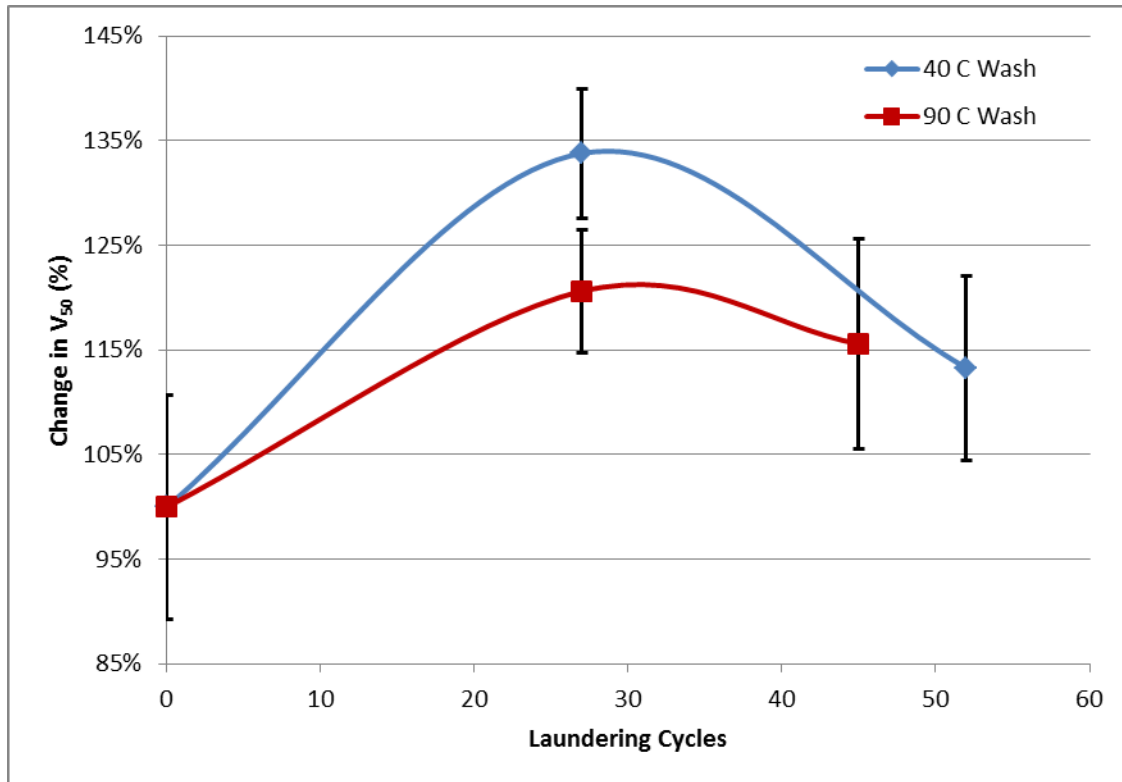

Figure 6-7 Change in ballistic protective performance for woven para-aramid against laundering cycles

As the increase in performance of the para-aramid fabrics observed in Chapter 3 increased significantly between 0 and 9 laundering cycles and then remained constant thereafter, would suggest that the greatest benefit is seen between 0 and 9 laundering cycles (Figure 6-8). After this increase at 9 cycles the performance stabilises for a period thereafter and would then be expected to slowly decline. It was not possible to deduce the point at which the performance of the para-aramid would

drop below the baseline from the number of laundering cycles investigated in this study, but it is expected that it would be at a point beyond the 52 laundering cycles.

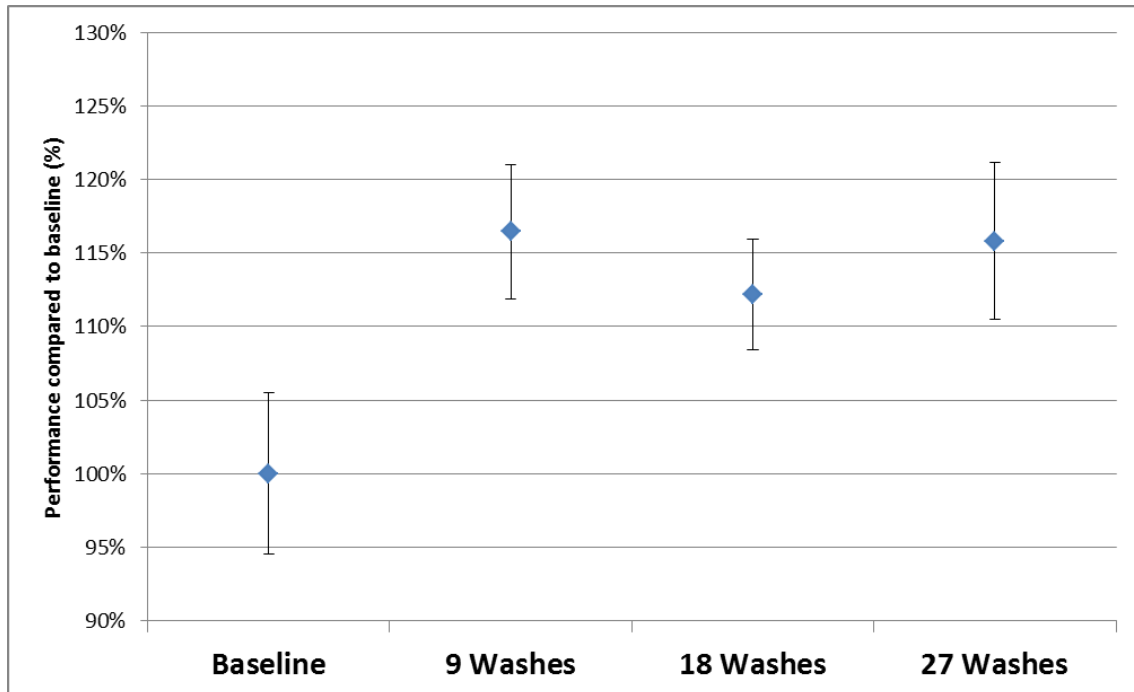

Figure 6-8 Performance of woven para-aramid due to laundering (from Chapter 3)

6.4.2 Felted fabrics

In the current study felts using two types of fibre were investigated; UHMWPE and para-aramid. The para-aramid felt showed similar changes in ballistic performance as seen in the woven para-aramid fabric (Figure 6-9). Under FESEM, both showed similar damage characteristics of fibrillation and surface roughening (Section 3.4). As has been discussed with the woven fabric, this roughening will affect the surface friction of the fibres. This roughening of the fibres allows greater interaction between fibres directly engaged with the projectile and secondary fibres, thereby pulling more of the fabric towards the projectile and transferring more of the energy from the

projectile into the fabric as a result. In the context of this study it resulted in an increase in ballistic protective performance.

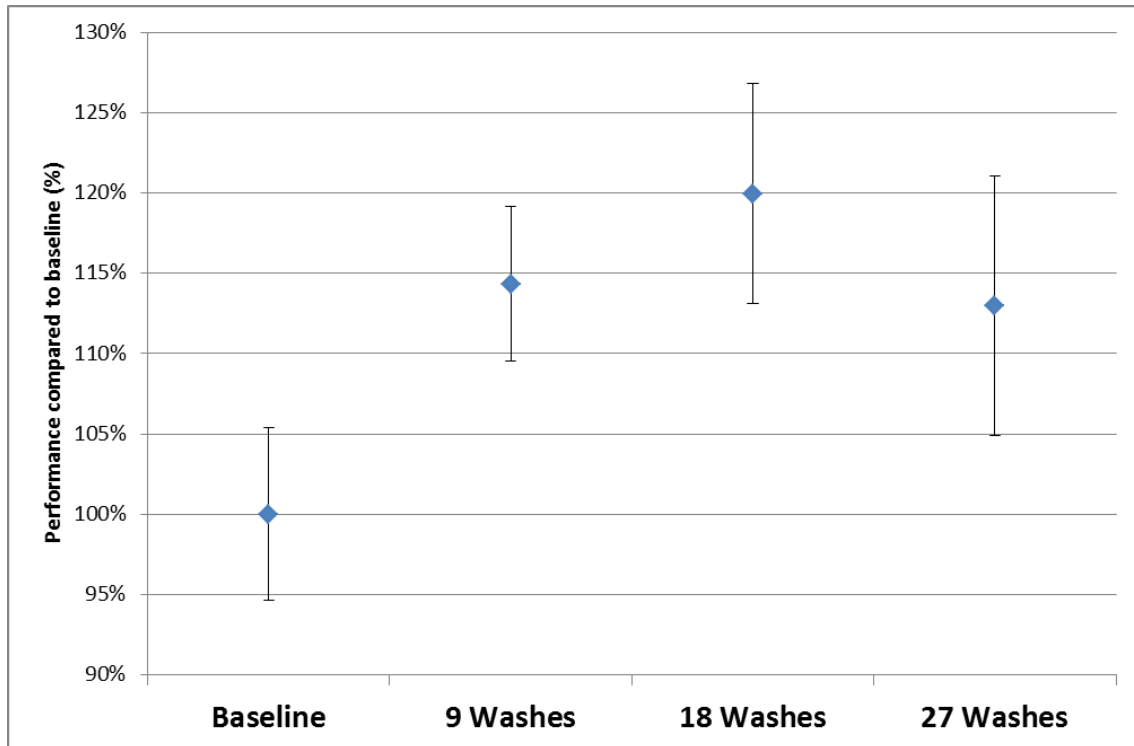

Figure 6-9 Performance of para-aramid felt due to laundering (Chapter 3)

In contrast the damage observed on the UHMWPE fibres suggested the damage was primarily along the length of the fibres and is unlikely to significantly increase the surface friction of the fibres. This does not allow for greater interaction between primary fibres in contact with the projectile and the secondary fibres, so no net benefit was observed. This is supported by there being little evidence of a change in ballistic protective performance of the UHMWPE felted fabric due to laundering as seen in Figure 6-10.

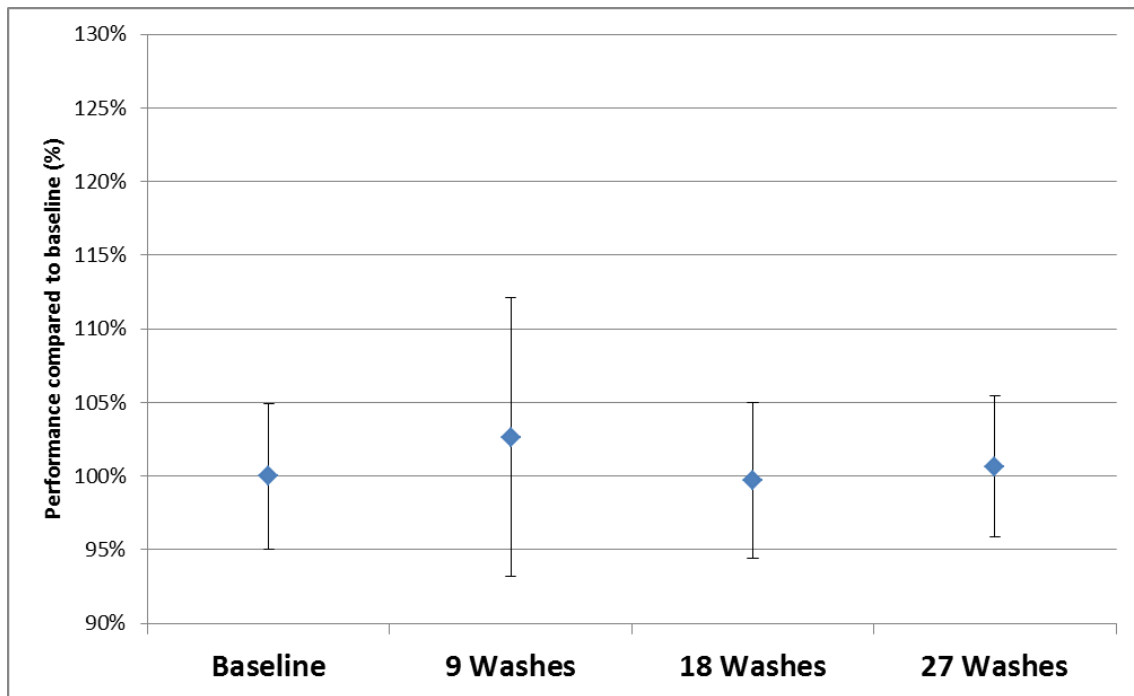

Figure 6-10 Performance of UHMWPE felt due to laundering (from Chapter 3)

6.4.3 Knitted fabrics

The silk fibres used in the knitted fabrics showed similar damage mechanisms to those observed in the para-aramid fibres. The surface of the fibres showed fibrillation and surface roughening. However, in the case of the knitted fabrics, there was no corresponding increase in the performance of the fabric. This is likely to be due to the lesser role of friction in the ballistic protective performance of the fabric as it extends more readily due to the nature of its structure. The yarns in the knitted fabric are less able to move over neighbouring yarns due to the fabric structure and the fabric is reliant on the ability of the fabric as a whole to move transversely. This is demonstrated by the lack of an observable change in fragment protective performance of the knitted fabric after laundering as seen in Figure 6-11.

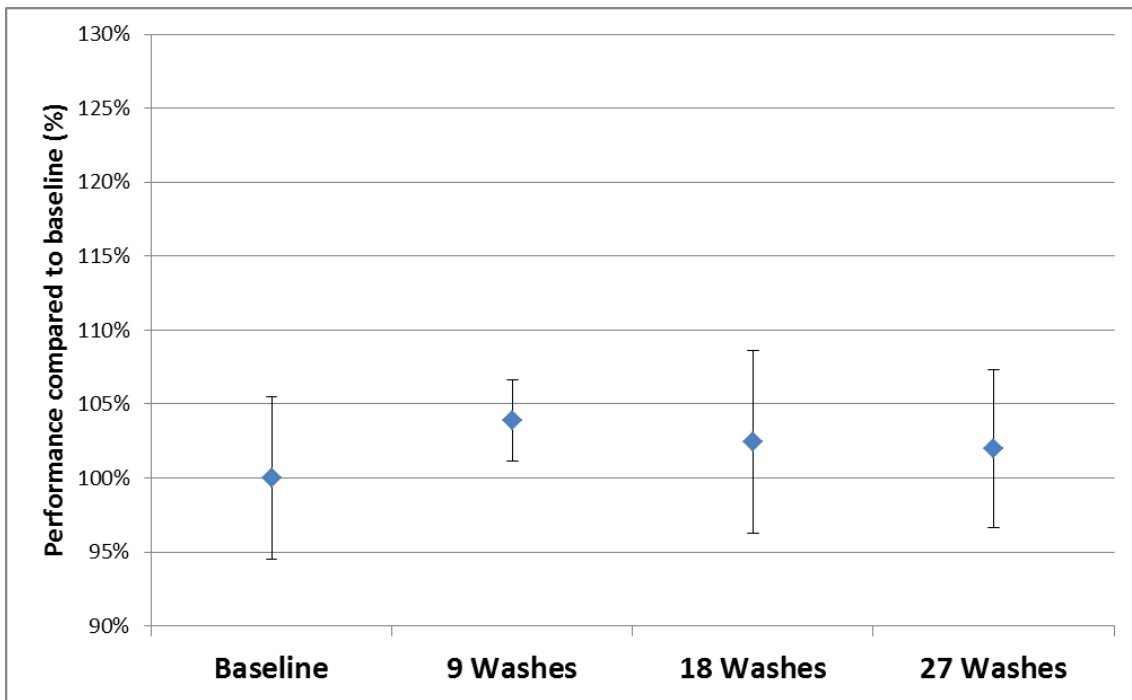

Figure 6-11 Performance of knitted silk due to laundering (from Chapter 3)

The hypothesis that knitted fabrics rely on the gross movement of the fabric in order to transfer energy from the projectile was supported when comparing the performance of the knitted and woven fabrics when mounted with and without backing materials. The backing material (in this case the UK MOD BABT Rig) acted to reduce fabric movement in the direction of the projectile (see Table 6-2). When the fabrics were mounted on the BABT Rig, the performance of the woven fabric was much greater than the knitted fabric. When the two fabrics were clamped in an open backed frame, the ability of both fabrics to stop the projectile was increased and both fabrics performed similarly. This is to be expected, as previously explained, knitted and felted fabrics rely on their ability to move with the projectile in order to transfer

energy from it rather than transferring the energy along the primary yarns and through crossovers with the secondary yarns.

Table 6-2 Relative performances of unconditioned knitted and woven fabrics tested backed and unbacked (“knitted backed” used as baseline)

	Backed		Unbacked	
	V ₅₀ (%)	SE (%)	V ₅₀ (%)	SE (%)
Woven	112	3	122	7
Knitted	100	3	127	5

In this study it was shown that the properties of the silk fibre was dominated by the properties of the knitted fabric. Therefore the change in the properties of the silk fibres was not reflected by a change in the performance of the knitted fabric.

6.5 Effect of laundering on other fabric properties

The effect of laundering on the dimensional and strength properties of woven, knitted and felted fabrics is well documented e.g. (Eisenhut, 1941, Hördler et al., 1976, Slater, 1991, Quaynor et al., 1999, Chen et al., 2004, Gore et al., 2006, Van Amber et al., 2010, Sawhney et al., 2012). For the fabrics investigated within the current study, laundering typically led to shrinkage of the fabrics.

6.5.1 Woven

Of the three fabric structures the woven fabric was the least affected by laundering taking into account the dimensional stability, mass per unit area and thickness of the

woven fabric. This is to be expected due to the recognised stability of woven fabrics after laundering due to the interlacing yarn nature of the fabric structure fixing the yarns in place. A minor reduction in the ball burst strength of the fabric was measured after laundering but the loss in strength of fabric did not correlate with the ballistic test results. It would suggest that fragment protective clothing incorporating woven para-aramid would be dimensionally stable and offers a greater advantage to the use of such fabrics in a clothing system.

6.5.2 Felted

Of the three fabric structures, the felted fabrics were the most severely affected by laundering. Changes in dimensions of the sample panels were similar in both the para-aramid and UHMWPE fabrics investigated. In both felted fabrics panels shrank in both the X and Y directions and showed a corresponding increase in fabric thickness. Felted fabrics are known to shrink during laundering (e.g. (Chen et al., 2004, Sawhney et al., 2012)). The level of felt shrinkage observed in this study was likely to be reduced as a result of the quilting of the sample panels, minimising the movement of the fabric during the laundering process. Unlike the knitted and woven fabrics the ball burst strength of the felted UHMWPE showed some evidence of increasing as a result of laundering. This may be due to the increased amount of fabric engaging with the probe during the test. Of the fabrics investigated in this study, the felts performed better than the woven and knitted fabrics against the 0.24

g chisel nosed FSP i.e. provided a higher level of protection. If this fabric type is to be of use in fragment protective clothing, additional measures, such as additional quilting, would need to be investigated in order to reduce shrinkage of the fabric affecting the wear properties of the clothing system. However, the measured increase in thickness would result in increased thermo-physiological loading of the wearer.

6.5.3 Knitted

The knitted fabrics used in this study shrank after laundering; this observation is supported by other research into the effect of laundering on knitted silk e.g. (Quaynor et al., 1999, Quaynor et al., 2000, Van Amber et al., 2010). Changes in the mass per unit area and thickness of the fabric were also observed in this study. There was little evidence that there was a loss in strength in the fabric measured by the modified ball burst test. There was no assessment of the effect of normal wear on the fabrics as finished garments. It is not possible to state whether the level of shrinkage observed had a temporary or permanent effect.

6.6 Effect of laundering regimes

In this thesis different methods of washing and drying were used. Due to unavailability of equipment, two different sets of washing machines and tumble dryers were used in this work. In addition to this a cement mixer was also employed to determine whether the effects of laundering observed were unique to the type of

washing machine, or whether the trends were similar irrespective of the laundering method employed. As the damage observed in Chapter 3, Chapter 4 and Chapter 5 were visually similar, this showed that the type of degradation imparted to the fabrics and fibres were universal. The damage observed in Figure 3-4, Figure 3-5 and Figure 3-6, was consistent with that seen in Figure 4-9, Figure 4-12 and Figure 4-15. The panels laundered using the cement mixer in Chapter 4 and the panels just tumbled in water in Chapter 5, were both line dried in comparison with the other laundering regimes, yet the types of damage and their affect (or otherwise) on the ballistic protective performance of the fabrics were similar. This showed that the method of drying did not play a significant part in the mechanisms causing degradation to the fabrics. Wash temperature was shown to have played a significant role in the degree of degradation imparted to the fabrics, but not to the type of degradation observed. In Chapter 4, a difference could be observed in fabric properties between the two wash temperatures, though the nature of the change depended upon the fibre type. For example, silk was shown to be more affected by a wash at 40 °C than at 90 °C, yet para-aramid performed better after laundering at 40 °C than at 90 °C. Although there was a difference in the level of change in the performance of the woven para-aramid between that seen in Chapter 3 and that in Chapter 4 (see Table 6-3), this is possibly due to the difference in the two fabrics

used and the change in mounting method, as the panels in Chapter 4 were tested without a backing, which would allow more movement of the fabric.

Table 6-3 Relative change in performance of para-aramid laundered at 40 °C for 27 cycles (Chapters 3 and 4)

	Chapter 3		Chapter 4	
	V ₅₀ (%)	SE (%)	V ₅₀ (%)	SE (%)
Para-aramid	115.8	3	133.8	3

6.7 Summary

In this study the use of three different fibres (silk, UHMWPE and para-aramid) and three fabric structures were investigated (knitted, felted and woven). The ballistic performance of the fabrics was assessed using the V₅₀ method against a 0.24 g chisel nosed fragment simulating projectile (FSP) (Ministry of Defence, 1993). The beneficial properties of a fabric and fibre that contribute to its ballistic protective performance vary, depending upon the shape, size and material of the projectile the fabric is optimised to stop. Fabrics stop a projectile by spreading the impact energy across as much of the fabric as quickly as possible, before the force applied to the fibres reaches a point where the fibres fail. This is achieved by engaging as many fibres as possible with the projectile, whilst minimising the projectile's ability to push fibres and yarns aside.

The contribution of fibre properties to the performance of fabrics during a ballistic impact varied according to the fibres type and fabric structure. For the knitted silk, the properties of the fabric structure dominated under ballistic impact. The degradation of the UHMWPE fibres did not appear to change the felted fabric's performance during a ballistic impact. For the two para-aramid fabrics (felted and woven), the performance of the fibre dominated over that of the fabric. Results presented in the open literature suggest that this will be the same for knitted fabrics made of para-aramid.

Changes to the fabric strength did not correlate to the change in ballistic protective performance. The ballistic protective performance of the woven and knitted fabric made of para-aramid was shown to be improved through laundering. It was not identified at which point the performance would begin to drop, but there was evidence that the peak improvement in performance occurred before 9 laundering cycles.

The change in performance of fabrics manufactured from the three fibres was due to mechanical wear. The rate of mechanical wear was significantly increased when the fabrics were wet. The water increased the intra-fibre/intra-yarn friction in the silk and para-aramid fibres, and this increased the effect of mechanical wear. The damage to the fibres acted to increase their ability to engage cross over yarns, increasing the rate of energy transfer from the projectile to the fabric thus taking it away from the

point of impact. This effect was most apparent within felted and woven fabrics as these rely on fibres locking together to transfer energy, rather than the knitted fabric which relies more on the ability of the fabric to move in the direction of the projectile through stretch of the knit. Mechanical wear in isolation caused only minor damage to the fabrics investigated.

The UHMWPE fibres exhibited damage through localised swelling and longitudinal splitting. This was consistent with damage imparted due to the bending of the fibres. There was no evidence that this damage affected the fabric's ballistic protective performance as these mechanisms would not provide the fibre greater ability to transfer energy to neighbouring fibres.

It was shown that the method of laundering played only a minor role in the degradation, where laundering with different washing machines or a cement mixer imparted similar degradation to the fabrics.

The findings of this study have implications for future procurements of fragment protective clothing, such as the procurement of PETREL, the UK MOD competition for the next generation of Combat Protective Equipment (CPE) Clothing. The results of this study have shown that all fragment protective fabrics investigated within this study can be suitable for these applications. The fabrics investigated were more robust than had been thought and with the insights gained through this study, their performance over the life the garments can be managed. The single statement of

user need (SSUN) for PETREL is (Survivability Requirements Manager 1 STSP DCC, 2017):

“The User shall be issued with a clothing system that will provide personal protection against climatic (Temperate, Warm Weather), environmental and fragmentation threats, whilst integrating with other Combat Protective Equipment within the Integrated Soldier System, reducing the physical burden and providing greater agility, whilst maintaining overall survivability and improving operational effectiveness.”

6.8 References

- Bazhenov, S. L. 1997. Dissipation of energy by bulletproof aramid fabric. *Journal of Material Science*, 32:4167-4173.
- Bazhenov, S. L. & Goncharuk, G. P. 2012. A study of yarn friction in aramid fabrics. *Polymer Science Series A*, 54(10):803-808.
- Bourget, D., Withnall, C., Palmer, S., et al. 2012. Aged Body Armour Testing: Further Results. *Personal Armour Systems Symposium 2012*. Nuremburg, Germany. .
- Carr, D. J. 1999. Failure mechanisms of yarns subjected to ballistic impact. *Journal of Material Science*, 18:585-588.
- Cheeseman, B. A. & Bogetti, T. A. 2003. Ballistic impact into fabric and compliant composite laminates. *Composite Structures*, 61(1–2):161-173.
- Chen, Q. H., Au, K. F., Yuen, C. W. M., et al. 2004. An Analysis of the Felting Shrinkage of Plain Knitted Wool Fabrics. *Textile Research Journal*, 74(5):399-404.
- Cunniff, P. M. 1992. An analysis of the system effects in woven fabrics under ballistic impact. *Textile Research Journal*, 62(9):495-509.
- Dalzell, M. W., Long, L. R., Slusarski, K. A., et al. 2013. Ballistic Characterization of Fabrics for Groin and Extremity Protection, Including Continuous-Filament Knit Aramids. ARL-TR-6412. Army Research Laboratory. Aberdeen Proving Ground, MA, US.
- DHB Armor Group. 2004. DHB Armor Group Armor Safety Report. DHB Industries Inc. USA.

- Duan, Y., Keefe, M., Wetzel, E. D., et al. 2005. Effects of friction on the ballistic performance of a high-strength fabric structure. *WIT Transactions on Engineering Sciences*, 49:219-229.
- Eisenhut, O. 1941. Zur Frage der Bestimmung des Schädigungswertes von Fasern, Garnen oder Geweben aus Zellulose und von Zellstaffen. *Melliand Textilber*, 22:424-426.
- Gibb, R. M. 2005. *The Effect of Water on the Performance of Ballistic Textile*. MSc, Cranfield University.
- Gore, S. E., Laing, R. M., Wilson, C. A., et al. 2006. Standardizing a pre-treatment cleaning procedure and effects of application on apparel fabrics. *Textile Research Journal*, 76(6):455-464.
- Greenwood, K., Cork, C. R. & Downes, L. 1990. Ballistic Penetration of Textile Fabrics - Phase V. Contract Number 2044/156 CDE/SC. Manchester University. Manchester, UK.
- Hearle, J. W. S., Leech, C., Adayefa, A., et al. 1982. Ballistic Penetration of Textile Fabrics - Phase II. University of Manchester. Manchester, UK.
- Hearle, J. W. S., Lomas, B. & Cooke, W. D. 1998. *Atlas of Fibre Fracture and Damage to Textiles (2nd Edition)*, Woodhead Publishing.
- Hearle, J. W. S. & Purdy, A. T. 1971. Research on energy absorption by nonwoven fabrics. DAJA-A37-71-C-0554. University of Manchester. Manchester, UK.

Hockenberger, S. A. 1998. The Effects of Weaving on Fibre Performance in Ballistic Fabrics Made from High-performance Polyethylene Fibres. *Journal of the Textile Institute*, 89(3):595-604.

Hördler, J., Mizner, F. & Hetzer, R. 1976. Veränderung der Reissfestigkeit, des DP-Grades und des Schädigungs faktors nach mehrmaligem Waschen van Textilien. *Melliand Textilberichte*, 10:853.

Ipson, T. W. & Wittrock, W. P. 1966. Response of non-woven synthetic fiber textiles to ballistic impact. Technical Report 67-8-CM. Denver Research Institute. Denver, Colorado, US.

Laible, R. C. 1980. *Ballistic materials and penetration mechanics*, Elsevier Scientific Pub. Co.

Laible, R. C. & Henry, M. C. 1969. A review of the development of ballistic needle-punched felts. TS-167. U. S. Army Natick Laboratories. Natick, Massachusetts 01760.

Lund, G. V. & Waters, W. T. 1959. The Stability to Laundering of Fabrics Made from Cellulosic Fibers. *Textile Research Journal*, 29(12):950-960.

Ministry of Defence. Drawing A3/6723 - Fragment Simulating Projectile. 1993. A3/6723/3.

Morton, W. E. & Hearle, J. W. S. 2008. *Physical Properties of Textile Fibres*, Manchester, England, The Textile Institute.

- Morye, S. S., Hine, P. J., Duckett, R. A., et al. 2000. Modelling of the energy absorption by polymer composites upon ballistic impact. *Composites Science and Technology*, 60(14):2631-2642.
- Phillips, I. J. 2005. Environmental Degradation of PBO (Zylon) Textile Body Armour. Defence Academy. Shrivenham.
- Quaynor, L., Nakajima, M. & Takahashi, M. 1999. Dimensional Changes in Knitted Silk and Cotton Fabrics with Laundering. *Textile Research Journal*, 69(4):285-291.
- Quaynor, L., Takahashi, M. & Nakajima, M. 2000. Effects of Laundering on the Surface Properties and Dimensional Stability of Plain Knitted Fabrics. *Textile Research Journal*, 70(1):28-35.
- Roylance, D. 1980. Stress wave propagation in fibres: Effect of crossovers. *Fibre Science and Technology*, 13(5):385-395.
- Roylance, D., Wilde, A. & Tocci, G. 1973. Ballistic Impact of Textile Structures. *Textile Research Journal*, 43(1):34-41.
- Sawhney, P., Reynolds, M., Allen, C., et al. 2012. Effect of Laundering Hydroentangled Cotton Nonwoven Fabrics. *Journal of Engineered Fibers and Fabrics*, 7(3):103-110.
- Shim, V. P. W., Tan, V. B. C. & Tay, T. E. 1995. Modelling deformation and damage characteristics of woven fabric under small projectile impact. *International Journal of Impact Engineering*, 16(4):585-605.
- Slater, K. 1991. *Textile degradation*, The Textile Institute.

- Sullivan, J. F. 1945. Resume of Programs on Development of Body Armor Undertaken at Watertown Arsenal during World War II. WAL Experimental Report 710/747. Watertown Arsenal. Watertown, USA.
- Survivability Requirements Manager 1 STSP DCC. 2017. Integrated Soldier System (ISS) Pulse 1 - Combat Protective Equipment Clothing (CPE Clothing) System Requirements Document. Soldier Training and Special Projects, Defence Equipment & Support, UK MOD. Abbey Wood, UK.
- Tan, V. B. C., Shim, V. P. W. & Zeng, X. 2005. Modelling crimp in woven fabrics subjected to ballistic impact. *International Journal of Impact Engineering*, 32(1–4):561-574.
- Ting, C., Ting, J., Cunniff, P. M., et al. 1998. *Numerical characterization of the effects of transverse yarn interaction on textile ballistic response*, Covina, USA, Soc Advancement Material & Process Engineering.
- Tobin, L. B. 1985. Ballistic performance of woven knitted and felted materials against fragment simulators. SCRDE-Technical-Memorandum-85-3. Stores and Clothing Research and Development Establishment.
- Van Amber, R. R., Niven, B. E. & Wilson, C. A. 2010. Effects of Laundering and Water Temperature on the Properties of Silk and Silk-blend Knitted Fabrics. *Textile Research Journal*, 80(15):1557-1568.
- Wilson, K. 1982. The water absorption of body armour materials and their ballistic performance against fragment simulators. SCRDE/81/16. Stores and Clothing Research and Development Establishment. Colchester.

Withnall, C., Garland, L. & Bourget, D. 2010. Aged Body Armour Testing in
Development of a Replacement Protocol. *Personal Armour Systems
Symposium 2010*. Quebec, Canada. .

7 CONCLUSIONS

This study concluded that:

1. The ballistic protective performance of the silk and UHMWPE was unaffected by laundering, whereas para-aramid fabrics are improved by laundering. This improvement was due to an increase in inter-yarn friction allowing more energy from the projectile to be dissipated across the fabrics. This has implications for the assessment of the long term robustness of the fabrics investigated in this study.
2. Mechanical wear due to laundering was the most significant factor in the degradation of the selected fabrics.
 - a. Domestic laundering did not alter the surface chemistry of the three fibres under investigation.
 - b. The degradation of silk and para-aramid were characterised by surface peeling of the fibres and fibrillation. The degradation of the UHMWPE fibres was characterised by localised swelling and longitudinal splitting.
 - c. The combination of water and mechanical movement of the layers of fabric over each other was responsible for the degradation of the fabrics. The presence of water greatly increased the inter-fibre friction, increasing the rate of mechanical wear of the fibres. The service life of fragment protective fabrics can be improved by preventing the fabrics

from coming into contact with water (such as those used in body armour).

3. In this study, all three fibre types were shown to be suitable for use in fragment protective clothing.

a. Of the three fabric types, knitted and woven fabrics were more dimensionally stable for use in fragment protective clothing.

b. The long term robustness of the fabrics investigated showed them to be sufficiently durable to be incorporated into fragment protective clothing for at least the duration of the UK clothing replacement policy at the time of the study (six months on operational tours and twelve months in barracks).

4. The work presented in this thesis supported the development, design and procurement of fragment protective clothing that was used by British Armed Forces on Operations in Afghanistan and has provided a basis for the future development of fragment protective clothing systems.

8 FUTURE WORK

During the course of this study a number of areas of future work have been identified as worthy of further investigation, that were not within the original scope of this study.

8.1 Determining the point at which ballistic protective performance of selected fabrics degrades through laundering

In this study the effect of limited laundering has been characterised. Future work could be conducted to identify the level of laundering required to degrade the ballistic protective performance. This would also seek to identify if the degradation is gradual, or whether there comes a point where performance decreases at an increased rate.

8.2 Determining the effect of laundering on the ballistic protective properties of selected fabrics from other threats

Does the change in performance of the selected fabrics through laundering differ when the threat projectile is changed, or when thicker packs of fragment protective fabrics are used to provide greater levels of protection.

8.3 Can body armour fabrics be improved through conditioning with mechanical wear

Mechanical wear on fibres is a significant cause of degradation in fragment protective fabrics. The results of this study have shown that this degradation can provide beneficial changes in the performance of para-aramid fabrics. It is still

unknown where the optimum level mechanical wear on para-aramid fibres occurs.

Can a technique for optimising the conditioning of para-aramid be developed?

8.4 Characterising the performance of knitted fragment protective fabrics for light weight applications

Traditionally knitted fabrics have shown little merit in fragment protective applications. This has in part been due to the range of testing that has been conducted. Published work on the performance of knits in ballistic protection have used staple fibres and been tested with relatively large FSP. Testing with continuous fibres has shown that these knits can achieve performance similar to their woven counterparts. It has also been identified that low areal density fragment protective knits of low performing fibres can perform equally with woven para-aramid against small, relatively slow FSP. The mechanisms by which knits stop FSP are not well understood. Further study would seek to determine the mechanisms by which knits perform, with the potential to identify a range of performance where they may exceed the traditional woven para-aramids.

8.5 Assessment of the change in comfort properties of selected fabrics for clothing applications

Assess the change in comfort properties of the fabrics due to laundering. No assessment of comfort was made in this study, which may limit the use of these types of fabrics in clothing systems (i.e. flexibility, weight, temperature etc.).

Appendix A – Statistical methods (Probit)

This appendix details the statistical method used for calculating the V_{50} performance of the selected fabrics within this thesis. The appendix is in the form of a conference paper. The author wishes to acknowledge the significant contribution of his co-authors, who prepared the majority of this paper. This is reflected in the author of this thesis being the third author on the paper. The author's contribution to the paper was in the selection of the BRGLM model for the study, setting the requirement for analysing different velocity selection strategies and joint development of the proposed velocity selection strategy, with Ralph Mansson.

The Development of a Critical Perforation Analysis Tool for Armour Testing

Ralph Mansson¹, Sam Ellis², **Mark Helliker**¹, Laura Craddock¹, Lisa Baker¹

¹ Defence Science and Technology Laboratory, Ministry of Defence, Porton Down, Salisbury, UK

² Defence Ordnance and Safety Group, Ministry of Defence, Abbey Wood, UK

Abstract. In recent years the validity of the method of assessing the ballistic limit of armour has been called into question. These methods were originally developed for the testing of steel armours and were then adopted for the testing of composite armours. Work presented at PASS 2012 showed how these methods can be prone to bias. Dstl started the development of a Critical Perforation Analysis Tool in 2008, based on the Probit Statistical method. This presentation covers the work conducted to develop the tool, including how the tool can be used in the experimental design to reduce the risk of bias and provide more meaningful comparisons of armours. The benefit the tool provides beyond reducing statistical bias is to potentially reduce the amount of testing required to achieve a high level of statistical confidence in the results. The tool is currently implemented within the statistical software package R, and work is under way to produce the tool in a standalone form in order to facilitate the sharing of the tool.

A.1 Introduction

It has been shown previously that well established methods of estimating the ballistic limit of an armour can be open to bias for some types of armour (Andres et al., 2012, Riley et al., 2012). In 2008, the Defence Science and Technology Laboratory (Dstl) embarked on the development of alternative methods for assessing the ballistic limit of an armour, based on work conducted at Cranfield University (Leeming et al., 2002). Based on the work conducted by Quelch (Leeming et al., 2002), a tool using a Probit statistical analysis implemented in the “R” (citation) was developed. Critical Perforation Analysis (CPA) covered the statistical considerations for designing and analysing data from ballistic testing where the outcome of the trial is a binary response describing whether there was perforation at a given velocity. The aim of the trial is to collect data to estimate the V_{50} and standard deviation of the velocity required for perforation of an armour system. The trial should also provide sufficient precision in these estimates to allow useful statements to be made about ballistic performance and for comparison based on other factors, such as batch to batch variation.

The data collected during these ballistic trials is a binary outcome with an associated velocity and probit analysis is a commonly used statistical method for analysing binary data (Finney, 1947). A statistical design of experiment

methodology has been used to identify a reliable approach to estimating metrics of interest, such as the V_{50} , leading to an adaptive design with two stages. The first stage is based on finding the velocity range where there are a mixture of perforations and no perforations. The second stage is a refinement to focus the trials on velocities that fall within this range.

A.2 Probit analysis

Bliss (Bliss, 1934, Bliss, 1935) introduced probit analysis which was presented as a manual analysis. This analysis involved a simplification by introducing a transformed variable, the probit, which avoided negative values. A subsequent analysis, developed by Fisher (Fisher, 1935), used an iterative solution of a weighted linear regression problem to produce the maximum likelihood solution. Finney (Finney, 1947) popularised the probit method and gave a detailed description of the manual analysis, including worked examples, using the iterative solution of weighted linear regression problem. The method is shown in Figure A-1 for the simplest case of a single explanatory variable, which is velocity for this application.

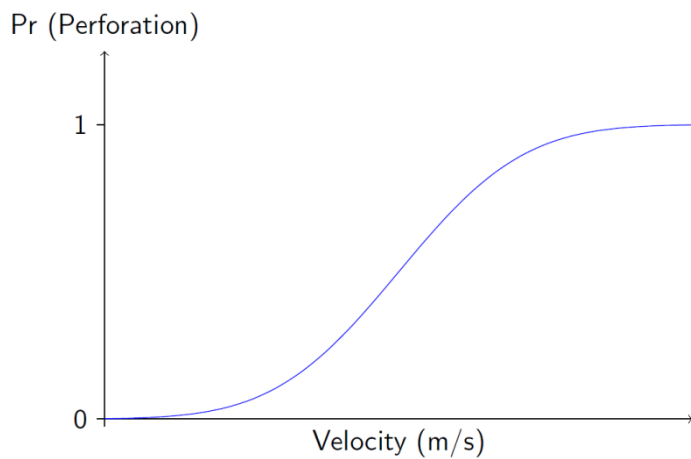

Figure A-1 An illustration of the sigmoidal shape of the probit curve shown for a single explanatory variable.

There are various methods that have been implemented to allow estimation of the mean and standard deviation of the velocity given a series of binary trials.

Maximum likelihood is available within R via the Generalized Linear Model (GLM) methodology introduced by McCullagh and Nelder (McCullagh et al., 1989).

The GLM has three components (Fox, 2002) that specify the range of distributions:

1. The random component, which is the distribution of the response measurements given the set of explanatory variables. This distribution can include Normal, Binomial, Poisson etc.

2. A linear predictor function which is comprised of the explanatory variables. This function is usually denoted η and can be a mixture of continuous or discrete variables.
3. A link function that transforms the response measurements onto the scale of the linear predictor function. The link function is typically denoted by $g(\mu) = \eta$ and forms the basis of the numerical algorithm for fitting the GLM to data.

The probit model is described by the probit link which is $\eta = \Phi^{-1}(\mu)$ where Φ is the cumulative distribution of the standard Normal distribution. The inverse function Φ^{-1} is the quantile function of the standard Normal distribution. The proportion of perforations, p , at a given velocity is therefore described by the equation below:

$$\Phi^{-1}(p) = \beta_0 + \beta_1 * Velocity$$

Where the parameters β_0 and β_1 are the intercept and slope on the linear predictor scale.

The GLM framework considers distributions from the exponential family and the maximum likelihood estimates of the parameters (β_0 and β_1 for this example)

are obtained using the iteratively weighted least squares (IWLS) algorithm. The IWLS approach follows these steps at the i^{th} iteration of the algorithm:

1. Calculate the working response values, z_i^t , from the linear predictor η_i , the observed data y_i , the inverse link function $g^{-1}(\eta_i^t)$ and the derivative of the link function.

$$z_i^t = \eta_i^t + (y_i - \mu_i^t) \left(\frac{d\eta}{d\mu} \right)_i^t$$

2. Calculate the working weights W_i^t using the variance function $V_i^t = V(\mu_i^t)$.

$$W_i^t = \left[\left(\frac{d\eta}{d\mu} \right)_i^t V_i^t \right]^{-1}$$

3. Fit the weighted regression of z_i^t on the explanatory variables x_i using weights. The coefficients of this model are the estimates of β at iteration i .

The algorithm runs until convergence in the estimates of β or the log-likelihood.

The asymptotic variance of the estimates of β is calculated from $\hat{\psi}(\mathbf{X}^T \mathbf{W} \mathbf{X})^{-1}$

where $\mathbf{W} = \text{diag}(W_1, \dots, W_n)$ is a diagonal matrix with elements equal to the

weights computed at the final iteration of the process. The dispersion parameter

ψ is either fixed a priori or estimated after the residuals are computed based on

the estimates of β .

A.2.1 Bias reduced algorithm

The GLM with binary data is occasionally affected by separation (which is the situation where the trial outcomes can be perfectly divided into perforation and no perforation based on a stimulus threshold e.g. velocity). The bias reduced GLM (BRGLM) was introduced by Kosmidis and Firth (Kosmidis et al., 2010) partially as a solution to the problems introduced by separation. The diagram in Figure A-2 shows a comparison of the probit model fitted by the BRGLM and GLM procedures for a simple data set.

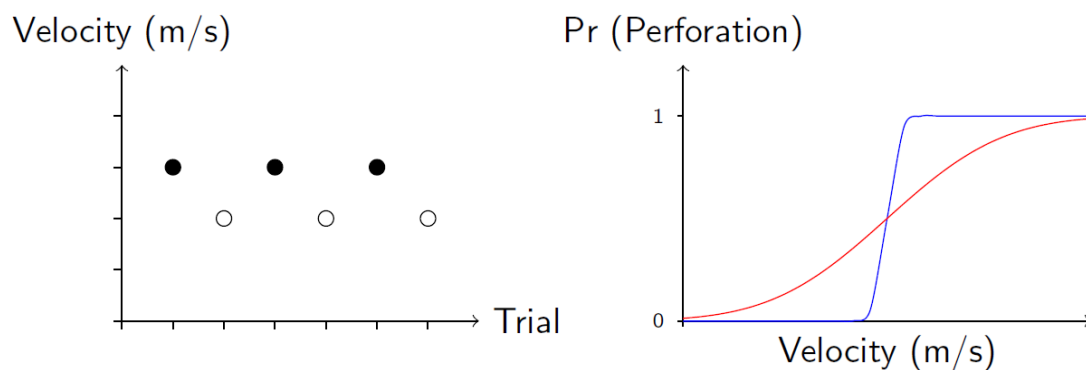

Figure A-2 Comparison of the glm (blue) and brglm (red) methods of analysis

The bias reduction approach is covered in detailed by Kosmidis (Kosmidis, 2007). The approach modifies the score equations of the maximum likelihood estimation approach to fitting GLMs and removes the leading term (Order n^{-1}) from the asymptotic expansion of the bias of the maximum likelihood estimator.

The algorithm creates pseudo-data by adjusting the successes and totals. Kosmidis (Kosmidis, 2007) (p68) shows the modified score functional form for the t^{th} parameter in the probit model:

$$U_t^* = \sum_i \frac{\psi(\eta_i)}{\pi_i(1-\pi_i)} \left(y_i - \frac{1}{2} h_i \frac{\pi_i(1-\pi_i)\eta_i}{\psi(\eta_i)} - m_i \pi_i \right) x_{it}$$

The IWLS procedure can be modified to generate the bias reduced estimates for the probit model ((Kosmidis, 2007), section 3.8). The working observations are modified by subtracting $S_{ii}\eta_i/2$ where $S_{ii} = \mathbf{x}_i^T (\mathbf{X}^T \mathbf{W} \mathbf{X})^{-1} \mathbf{x}_i$ is the asymptotic variance of the i^{th} predictor η_i and \mathbf{W} is a diagonal matrix with elements equal to the working weights for each of the n observations. The pseudo-data representation ((Kosmidis, 2007), p71) for the probit model is:

Pseudo-responses $y_i^* = y_i + \frac{1}{2} h_i \left(-\frac{\pi_i \Phi^{-1}(\pi_i) I(\pi < 1/2)}{\psi(\Phi^{-1}(\pi_i))} \right)$

Pseudo-totals $m_i^* = m_i + \frac{1}{2} h_i \left(\frac{\Phi^{-1}(\pi_i) [I(\pi \geq 1/2) - \pi]}{\psi(\Phi^{-1}(\pi_i))} \right)$

The h_i are leverage values bound between 0 and 1. The steps of the algorithm using the pseudo-data representation is described in Kosmidis ((Kosmidis,

2007), Figure 5.2). The R implementation of brglm (Bias Reduced Generalized Linear Model) is based on the code for glm (Generalized Linear Model).

The help file for the R implementation of brglm (R Core Team, 2012) states that “estimation in binomial-response GLMs, the bias-reduction method is an improvement over traditional maximum likelihood because:

- the bias-reduced estimator is second-order unbiased and has smaller variance than the maximum likelihood estimator and
- the resultant estimates and their corresponding standard errors are always finite while the maximum likelihood estimates can be infinite (in situations where complete or quasi separation occurs).”

A.2.2 Estimation of V_{50} and standard errors

The probit model can be used for various purposes such as estimating a probability for a fixed velocity or the reverse situation of a velocity for a fixed probability of perforation. The latter case is most relevant for the CPA application. Figure A-3 provides an illustration of a confidence interval on the velocity for a fixed probability of perforation.

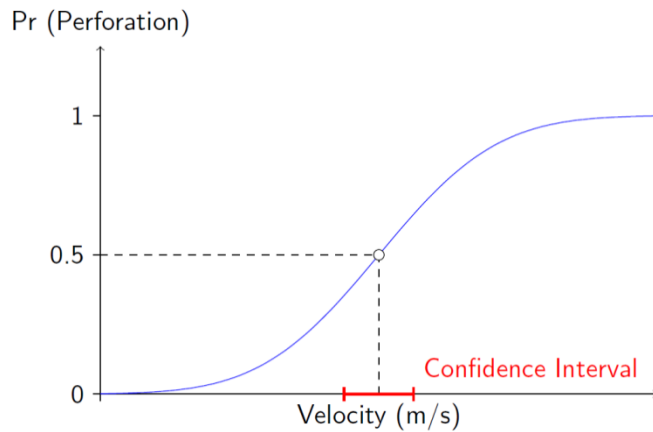

Figure A-3 The fitted probit model can be used to estimate metrics such as the V_{50} which is shown as a fixed probability but with uncertainty on the explanatory variable (velocity).

The probit model can be used to estimate the velocity for a fixed probability p by re-arranging the probit link equation:

$$\Phi^{-1}(p) = \beta_0 + \beta_1 * Velocity$$

To get the following relationship to calculate the velocity:

$$Velocity = \frac{\Phi^{-1}(p) - \beta_0}{\beta_1}$$

Approximate confidence intervals for a fixed probability can be calculated using the “delta” method (Oehlert, 1992). The delta method is a general technique for estimating the variance of a (usually non-linear) function of random variables. In this situation the parameters β_0 and β_1 are random variables with variance and

covariance provided as part of the maximum likelihood estimation procedure for GLMs.

The equation above is differentiated with respect to β_0 and β_1 separately and these factors are combined with the variance covariance matrix from the maximum likelihood fitting to give the following formula for estimating the variance of p and hence the standard error:

$$Var(Velocity) = \begin{bmatrix} \frac{\partial V}{\partial \beta_0} & \frac{\partial V}{\partial \beta_1} \end{bmatrix} \begin{bmatrix} \sigma_{\beta_0}^2 & \sigma_{\beta_0, \beta_1} \\ \sigma_{\beta_0, \beta_1} & \sigma_{\beta_1}^2 \end{bmatrix} \begin{bmatrix} \frac{\partial V}{\partial \beta_0} \\ \frac{\partial V}{\partial \beta_1} \end{bmatrix}$$

The standard error is the square root of $Var(Velocity)$ and can be used to construct approximate confidence intervals for the V_{50} and other quantiles of interest.

A.3 Trial design

There have been various experimental designs proposed for binary response data. The first was presented by Dixon and Mood (Dixon et al., 1944, 1948) and referred to as the Bruceton “staircase” method for analysing sensitivity data obtained by a new experimental procedure by the Explosives research Laboratory at Bruceton, Pennsylvania. In a staircase design an initial stimulus and step size are chosen and the next stimulus is decreased by one step after a

success (perforation) and increased by one step after a failure (non-perforation). The design is effective for finding the stimulus where there is a 0.5 probability of success.

Langlie (Langlie, 1962) developed a method for selecting stimulus levels which could be performed satisfactorily with smaller sample sizes. A lower (L) and upper (U) bound are selected for the stimulus and the initial trial (shot) is conducted at the mid-point of this interval. The interval is iteratively refined based on the outcome of the subsequent trials. The design is effective for finding the mean and standard deviation. Although considered an improvement over the Bruceton method because it avoids the fixed grid of stimuli it cannot recover if the original interval (L,U) does not cover a significant portion of the distribution.

The experimental design theory suggests that the stimuli where the probability of perforation is 0.175 or 0.825 are the most beneficial design points – shown in Figure A-4. This requires the mean and standard deviation to be known in advance and this is, of course, the purpose of the trial so it is of little use initially. Subsequent developments were based on optimal design principles with the stimuli selected based on statistical information derived from the data,

for example a function of the Fisher information for the maximum likelihood estimator.

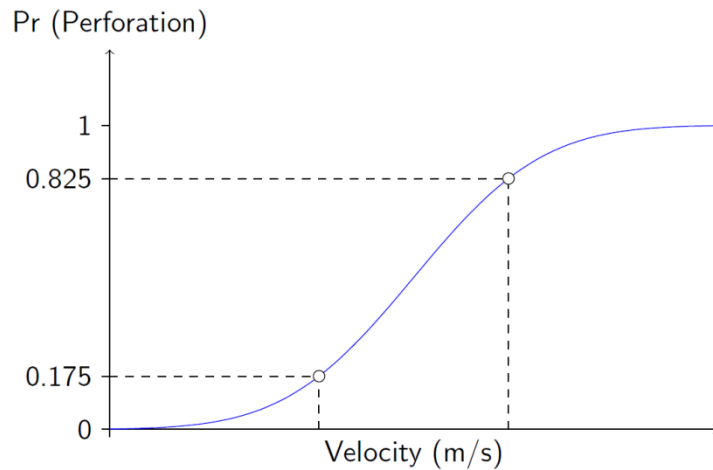

Figure A-4 The optimal design points for a logistic model identified by Russell et al. (2009). These points cover the linear part of the probit curve.

There are several optimality criteria (see for example Sitter and Wu (Sitter et al., 1997, Wu, 2012)) and optimal designs use one or more of these in one or more stages. In many examples a combination of the mean and standard deviation are of interest, for example when the probability of perforation or non-perforation is at some specified low level. Some designs are aimed at obtaining a good overall estimate of the full distribution, whilst others are aimed at getting a good estimate of a single point.

Neyer (Neyer, 1994) produced a three part trial using “D-optimal” design stimuli chosen to “maximize the determinant of the Fisher information matrix” which is aimed at obtaining a good curve. Baillie (2001) adapted this and produced a two part trial using “c-optimal” aimed at getting a good estimate of a single point. Neyer’s method used the positive root of a quadratic equation and Baillie adapted this by alternately using the positive and negative solutions and by adding factors to cope with bias in standard deviation and damping of wild values.

A.3.1 Comparison of four trials designs

A study into the relative merits of four experimental trials designs was conducted at Dstl. The simulation considered a range of experimental design strategies. These strategies were investigated by generating synthetic data sets to estimate the mean and standard deviation of the underlying stimulus distribution. The simulation was coded in R and a high performance computing (HPC) cluster was used to run a number of cases in parallel. These cases are based on the starting conditions for the experimental design.

The simulation study code has been written using the R programming language (R Core Team, 2012) and has been run in parallel on an HPC cluster to reduce the total running time for the simulations. The strategies simulated a series of

individual trials which were combined to create simulated experiments. The Probit model was fitted to these models using the glm (R Core Team (R Core Team, 2012)) or brglm (Kosmidis (Kosmidis, 2007)) function to get estimates of V_{50} and standard deviation. There was a check at the end of each simulation to reject cases where an unlikely set of trials would have occurred to reduce the impact of these on the simulation comparisons. In general there were 10,000 experiments simulated for each combination of design parameters.

A simulated ballistics trial run comparing 4 experimental designs was run. In each the ballistic outcome was sampled from a normal distribution with a mean of $500 \text{ m}\cdot\text{s}^{-1}$ and a standard deviation of $25 \text{ m}\cdot\text{s}^{-1}$. Each trial consisted of 40 samples (simulated shots), where the increments for adjusting the velocity were altered as was the deviation of the initial velocity (up to $100 \text{ m}\cdot\text{s}^{-1}$ above or below the actual mean):

- D1: Equally spaced velocities between a lower and upper limit.
- D2: Staircase design with fixed velocity step size.
- D3: Adaptive design starting with a staircase design followed by velocities chosen by probit analysis.
- D4: Langlie design.

A.3.2 Simulation of individual trials

The individual trials are simulated based on selected *true* parameters. The parameters of the Normal distribution that define the *true distribution of velocities required for perforation* are:

- V_{50} , the mean velocity, i.e. the velocity at which there is a fifty percent probability of success.
- V_{sd} , the standard deviation of the velocity, which defines the variability of the system.

The cumulative normal distribution function is used to calculate the probability of a successful trial (with the *true* parameters) at each trialled velocity. A random number from the uniform distribution (ranging from 0 to 1) is then used to determine whether the outcome of the trial is a success or failure.

A.3.3 Simulation of experiments

These individual trials are combined based on various strategies to generate a simulated experimental data set. The probit regression model is fitted to this data using either the **glm** or **brglm** function. The model parameter estimates are then used to calculate estimates of the mean (V_{50}) and standard deviation (V_{sd}).

A.3.4 Design evaluation

The simulation provides a range of estimates for the V_{50} and V_{sd} for a specific set of strategy parameters. This set of simulated values needs to be

summarised to compare the various strategies. The simulated distribution for the V_{50} and V_{sd} can be summarised by the mean and standard deviation of each to allow comparisons between the different design strategies. This gives four measures that we seek to minimise with the design strategy:

- V_{50} Bias: calculated as (actual V_{50} – mean simulated V_{50}).
- V_{50} Std Dev: standard deviation of simulated V_{50} .
- V_{sd} Bias: calculated as (actual V_{sd} – mean simulated V_{sd}).
- V_{sd} Std Dev: standard deviation of simulated V_{sd} .

The standard deviation was estimated using the mean absolute deviation to reduce the impact of outliers in the simulations.

A.3.5 V_{50} bias

The bias in the simulated V_{50} is small (less than $1 \text{ m}\cdot\text{s}^{-1}$) for all of the four designs in the simulation.

A.3.6 V_{50} standard deviation

The simulation generates a distribution of V_{50} values for each set of design starting parameters. These are shown in Figure A-5 provides a summary of how the standard deviation of the simulated distribution varies based on different choices of starting conditions for the design.

The D3 design has the smallest variation when compared to the other three designs. There are some cases when the other designs may have a smaller

simulated standard deviation but overall D3 performs better than the other three design approaches as the *worst* case choice of starting parameters is not substantially worse than the *best* cases for the other designs.

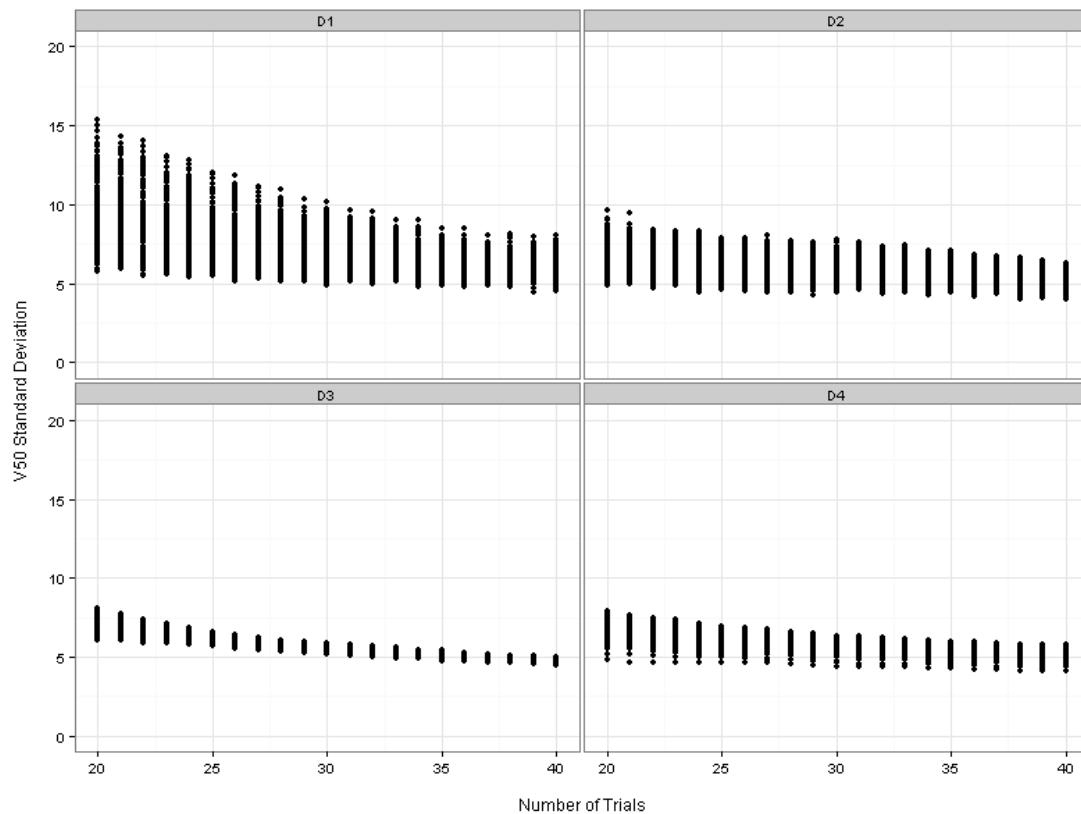

Figure A-5 Variation in the standard deviation of the simulated V_{50} across the design starting parameters. The graph shows the effect of increasing the number of trials.

A.3.7 V_{sd} bias

There are situations where there is bias in the simulated distribution of V_{sd} for designs D1 and D4 but this does not occur for the other two approaches D2 and D3.

A.3.8 V_{sd} standard deviation

The simulation generates a distribution of V_{sd} values for each set of design starting parameters. These are shown in Figure A-6 provides a summary of how the standard deviation of the simulated distribution varies based on different choices of starting conditions for the design.

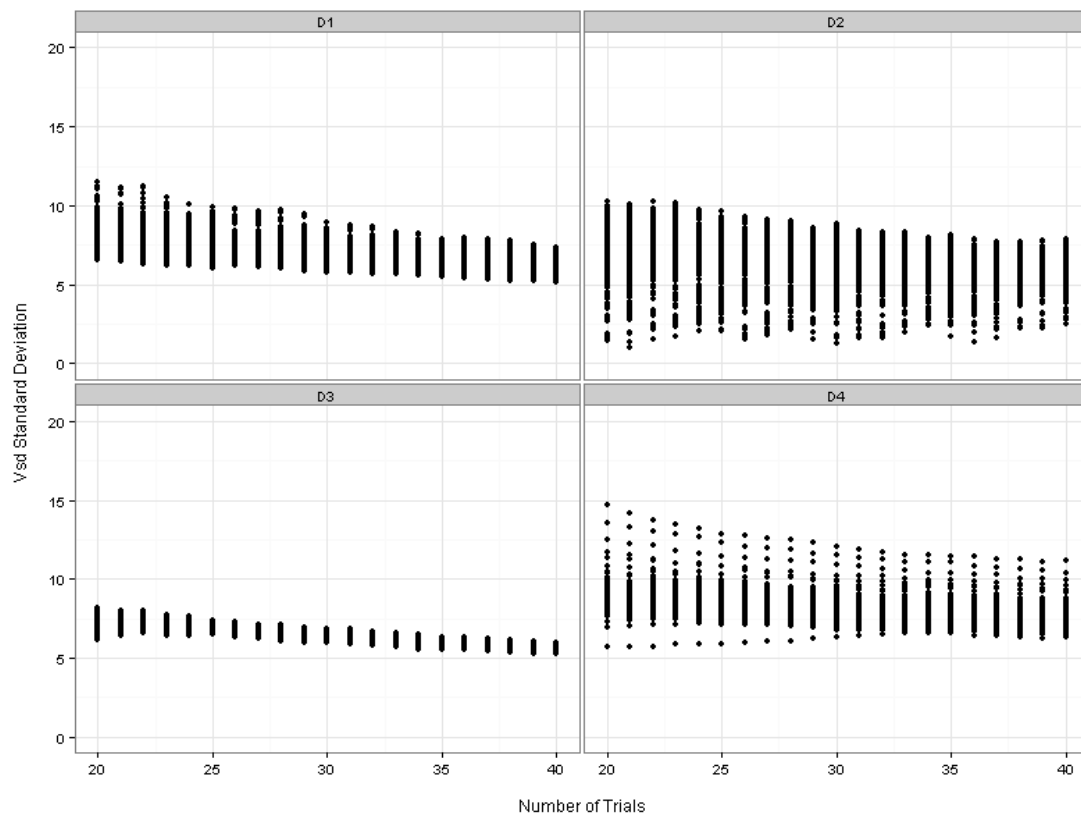

Figure A-6 Variation in the standard deviation of the simulated V_{sd} across the design starting parameters. The graph shows the effect of increasing the number of trials.

The designs D1 and D4 have larger standard deviations than D2 and D3. The D2 and D3 approaches have a staircase element while the D3 approach has an adaptive element that selects velocities that are good from a statistical perspective for estimating the V_{sd} . The D2 staircase can perform better than D3 but this requires precise selection of the starting velocity and step size which in practice is not possible as these values are unknown or estimated previously with uncertainty. The advantage of the D3 approach is that it will always perform well compared to the other three design approaches.

A.3.9 Proposed design

The recommended number of shots is a minimum of 40 for fabric armour systems and an adaptive experimental design is proposed for selecting the velocities for these trials. The trial is divided into two phases of 12 and 28 shots respectively. The first phase is a sighting phase to identify the “zone of mixed results” and the second phase is based on further experimentation within this zone.

Phase 1: the twelve shots are used to identify the “zone of mixed results” and the velocities above and below this zone to provide reassurance that the testing is in the area of interest. The objective is to divide the twelve shots between these three regions. Table A-1 provides a summary of the aim of the first phase.

Table A-1 Phase 1 trial objectives for the initial twelve shots in the experiment.

Region	Below ZMR	Zone of mixed results (ZMR)	Above ZMR
Outcomes	All no perforation	Mix of perforation and perforation	All perforation
Width	≥ 40 m/s	Armour dependent	≥ 40 m/s

Phase 2: at the end of phase 1 a probit model is fitted to the data from the first twelve shots. This model is used to estimate the V_1 , V_{20} , V_{80} and V_{99} for the current data. The shots in the second phase are divided into seven sets of four shots. The velocities for each set are calculated period to each set of four.

The trial continues until a minimum of 40 shots have been investigated. At the end of the trial a probit model is fitted to the complete set of data to estimate the V_{50} and its standard error and other metrics of interest from the trial.

A.4 Conclusions

This study has shown that the use of probit logistic regression can be used to provide a more comprehensive analysis of the probability of perforation for a ballistic trial. However, it has also been shown that the method of selecting test velocities is a more important factor. Some methods of velocity selection are open to experimental bias and risk skewing the test results. The relationship between the risk of experimental bias and the number of shots chosen has shown that an increase in the number of shots greatly reduces the risk of bias, but only when shots are spread across a wider velocity range. A method for selecting velocities to reduce bias is proposed and has been shown to eliminate experimental bias.

A.5 References

- Andres, C. & Boughers, W. 2012. An Analysis of V_{50} Ballistic Limit Results Adjusting 1st Shot Velocity, Step-Up Step-Down Increments, Truth Characteristics and Velocity Control Distributions. *Personal Armour Systems Symposium*. Cambridge, UK: IPAC.
- Bliss, C. I. 1934. The method of probits. *Science*, 79.
- Bliss, C. I. 1935. The calculation of the dosage-mortality curve. *Annals of Applied Biology*, 22(4):134-167.
- Dixon, W. J. & Mood, W. J. 1944. Statistical Analysis for a New Procedure in Sensitivity Experiments. Princeton University for the Office of Scientific Research and Development.
- Dixon, W. J. & Mood, W. J. 1948. A Method for Obtaining and Analyzing Sensitivity Data. *Journal of the American Statistical Association*, 43:109-126.
- Finney, D. J. 1947. Probit Analysis: A Statistical Treatment of the Sigmoid Response Curve, Cambridge University Press.
- Fisher, R. A. 1935. Appendix to Bliss (1935). *Annals of Applied Biology*, 22(4):164-165.
- Fox, J. 2002. An R and S-Plus Companion to Applied Regression, California, Sage Publications.

- Kosmidis, I. 2007. *brglm: Bias reduction in binary-response GLMs* [Online].
Available: <http://go.warwick.ac.uk/kosmidis/software>.
- Kosmidis, I. & Firth, D. 2010. A generic algorithm for reducing bias in parametric estimation. *Electronic Journal of Statistics*, 4:1097-1112.
- Langlie, H. J. 1962. A Reliability Test Method for One-Shot Items. Technical Report U-1792. Aeronutronic Division of Ford Motor Company.
- Leeming, D. W., Quelch, L. J., Fenn, P. M., et al. 2002. Fundamental Data and Analysis on the Penetration Resistance of a Textile Armour. *Personal Armour Systems Symposium*. Netherlands: IPAC.
- McCullagh, P. & Nelder, J. A. 1989. *Generalized Linear Models*, London, Chapman and Hall.
- Neyer, B. T. 1994. A D-Optimality-Based Sensitivity Test. *Technometrics*, 36(1):61-70.
- Oehlert, G. W. 1992. A note on the delta method. *American Statistician*, 46:27-29.
- R Core Team 2012. *R: A language and environment for statistical computing*, Vienna, R Foundation for Statistical Computing.
- Riley, M., Rice, K. & Forster, A. L. 2012. Assessment of Uncertainty in Ballistic Response Estimates Obtained from Ballistic Limit Testing. *Personal Armour Systems Symposium*. Cambridge, UK: IPAC.

Sitter, R. R. & B., F. E. 1997. Optimal two-stage designs for binary response experiments. *Statistica Sinica*, 7:941-955.

Wu, C. F. J. Three-Phase Optimal Design of Sensitivity Experiments.

Eighteenth Army Conference on Applied Statistics, October 2012 2012

Monterey

Appendix B - Development of a modified ball burst test

B.1 Introduction

During the course of the study, it became apparent that there were no suitable methods for measuring the change in strength of the fibres under investigation, due to the differing fabric structures. It was not possible to extract fibres from felted fabrics without imparting significant damage to the fibres in the process. There are questions over the validity of tensile yarns tests, where the method of clamping and the length of the yarn being tested are variable.

It was decided that a test assessing the strength of the fabric would be the most suitable method. Of the test methods available the BS EN ISO 9073-5:2008 offered the best potential (British Standards Institute, 2008). The method assesses the ability of the fabric to withstand perforation of the fabric from a probe. It was identified that the size and geometry of the probe used in the standard test was significantly different to the projectile that was used in the ballistic testing. It was therefore decided to modify the test method in order for the test to be more representative of the ballistic test setup. This was done in order to ensure that the failure mechanisms of the fabric were similar between the modified test and the ballistic testing.

B.2 BS EN ISO 9073-5:2008 Ball Burst Test

The ball burst test described in BS EN ISO 9073:2008 described a probe with a circular ball of diameter 25.4 mm being pushed through a layer of fabric held in a clamp of 44.5 mm internal diameter at a rate of $300 \text{ mm}\cdot\text{min}^{-1}$. The samples to be used must be 125 mm x 125 mm square sections of fabric. The maximum load in Newtons was recorded as the ball burst strength of the fabric. The tests were valid as long as the fabric did not fail where the fabric sample was retained in the clamp and no slippage of the fibres / yarns through the clamp was observed.

B.3 Modified ball burst test method

The experimental setup for the modified ball burst test can be seen in Figure B-1. In order to present a test more representative of the ballistic testing, the diameter of the probe was reduced to the diameter of the FSP used in the ballistic testing (3.25 mm). The internal diameter of the clamping ring was reduced to 5.7 mm, in order to maintain the same probe / internal clamp diameter ratio. The fabric samples were cut to approximately 50 mm x 50mm squares so the fabric did not interfere with the clamping bolts. The rate of the movement of the probe was maintained at $300 \text{ mm}\cdot\text{min}^{-1}$. Five samples were tested for each probe / orientation. Those same requirements regarding validity of testing (fibre slippage and location of fibre failure) were maintained. In order to ensure that these conditions were met, the clamping bolts were tightened to a torque setting of 10 Nm for the silk and UHMWPE fabrics

and 5 Nm for the para-aramid fabric. It was found that a lower torque levels resulted in fibre slippage, and higher torques results in the breaking of fibres at the edge of the clamping ring.

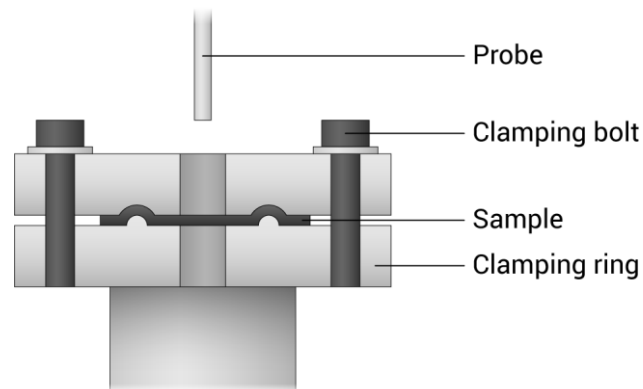

Figure B-1 Experimental setup for the ball burst test (Copyright 2017, Cranfield University Media)

Two probe types were assessed for suitability in the testing, a Chisel Nosed (CN) probe and a Right Circular Cylinder (RCC). The CN probe was more representative of the FSP used in the ballistic testing, whereas the RCC probe was expected to provide more consistent results. A short comparison of the two probe types was conducted to identify which of the probe designs would provide more consistent results, in order to increase the likelihood of identifying minor changes in ball burst strength of the fabrics. It was surmised that the orientation of the CN probe may affect the results on the woven para-aramid, but was unlikely to affect the results of the knitted or felted fabrics. As a result, a comparison was run on the woven para-aramid fabric only. The fabric samples were conditioned according to BS EN ISO

139:2005 only before testing took place (British Standards Institute, 2005). The samples were not-laundered prior to testing.

B.4 Results

The load (ball burst strength) against extension was measured and graphs of the results plotted. The maximum ball burst strength of the fabric samples was recorded and the means and standard deviations calculated. The standard deviation as a percentage of the mean was also calculated.

A comparison of the ball burst strength of the fabrics with the different probes / orientations are presented in Table B-1. The RCC recorded a higher ball burst strength compared the CN probe in either orientation. This is due to reduced slippage of the yarns with the RCC probe, in comparison with the chamfered edges present on the CN probe. The RCC probe is able to engage with more of the fabric at any point as it passes through the fabric. There is no evidence of a difference in the results between the two orientations of the CN probe. However, the standard deviation as a percentage of the mean ball burst strength for the probe at 0° (in line with the yarn) is lower than that for the probe at 45° (diagonally across the yarn).

Table B-1 Ball Burst Strength of woven para-aramid for different probe types / orientations

Run	Ball Burst Strength (N)		
	RCC	CN 0°	CN 45°
1	738.7	389.4	357.6
2	652.6	386.7	302.4
3	677.1	445.9	325.5
4	659.1	332.2	426.7
5	684.8	346.3	435.1
Mean	682.5	380.1	369.5
SD	34.0	44.4	59.5
SD (% of Mean)	5.0%	11.7%	16.1%

The graphs of the modified ball burst test are presented in sections B.4.1, B.4.2 and B.4.3.

B.4.1 CN Results at 0° orientation (in line with the yarn)

The plots of the load to extension for the CN probe at 0° are presented in Figure B-2.

The load applied as the probe passed through the fabric was variable from sample to sample. This was due to the chamfered edges of the CN probe engaging different yarns as it passed through the fabric.

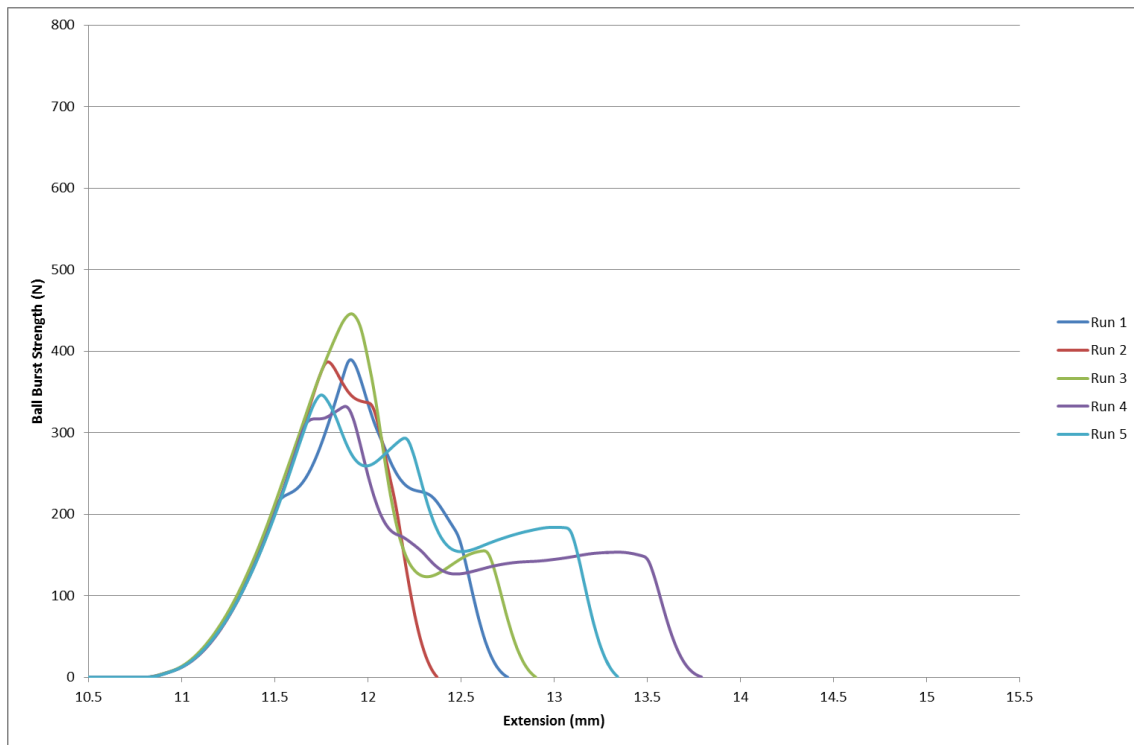

Figure B-2 Load to Extension for woven para-aramid against CN probe at 0° orientation

B.4.2 CN Results at 45° orientation (diagonal across the yarn)

The plots of the load to extension for the CN probe at 0° are presented in Figure B-2.

The load applied as the probe passed through the fabric was again variable from sample to sample. This was due to the chamfered edges of the CN probe engaging different yarns as it passed through the fabric. The plots showed a greater level of variation as different fibres failed at different points as the probe passed through the fabric. Although there was no evidence of a difference between the two orientations

in relation to the ball burst strength of the fabric, there was an obvious difference from load over distance travelled by the probe.

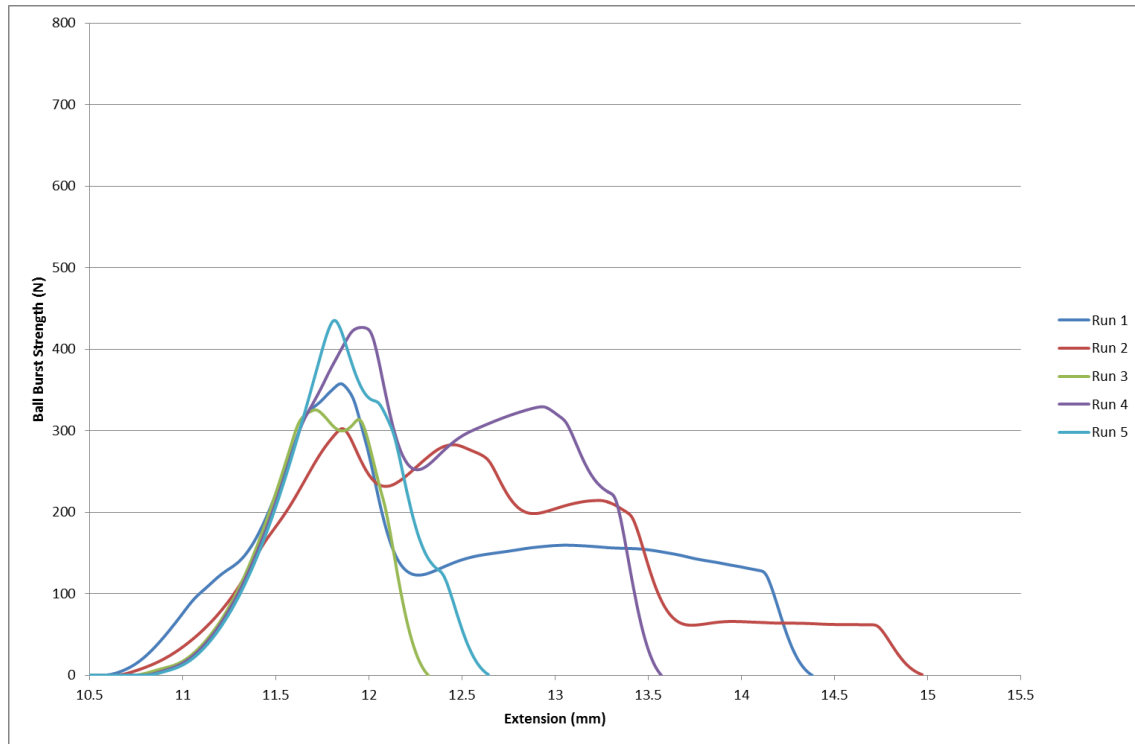

Figure B-3 Load to Extension for woven para-aramid against CN probe at 45° orientation

B.4.3 RCC Results

The plots of the load to extension for the RCC probe are presented in Figure B-4.

The RCC probe produced more uniform results in terms of ball burst strength, as well as the profile of the load to extension for the different samples.

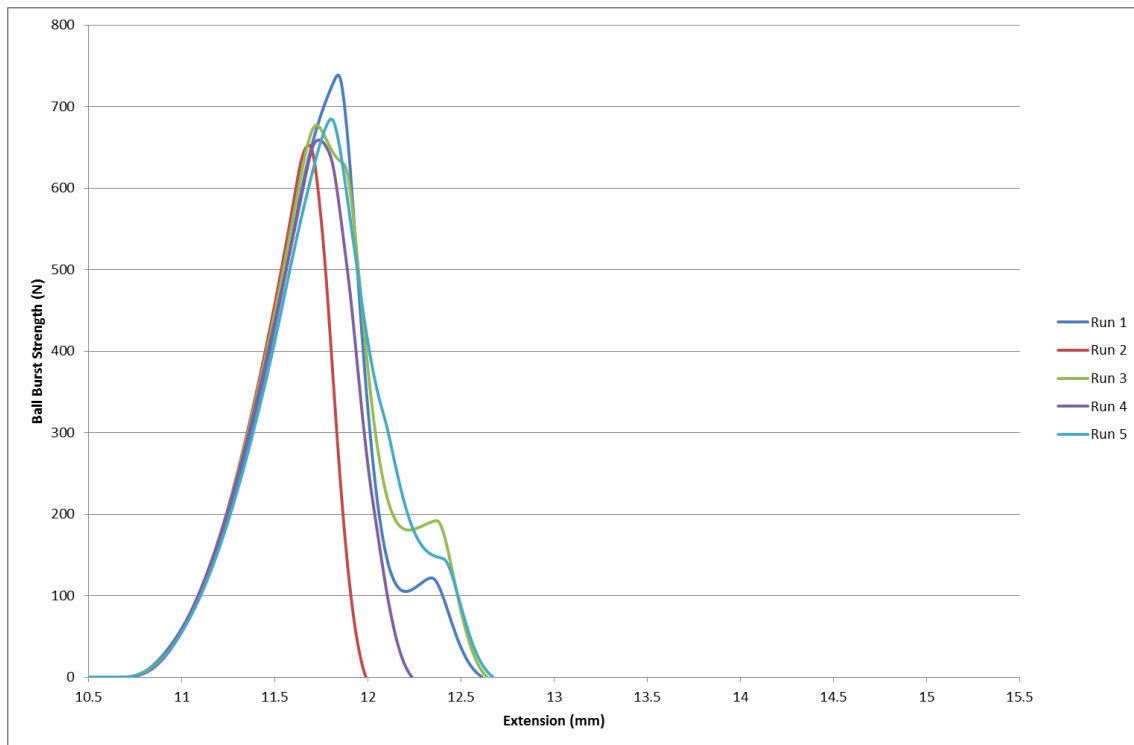

Figure B-4 Load to Extension for woven para-aramid against RCC probe at 0° orientation

B.5 Conclusions

The RCC probe presented more consistent results out of the two probe designs / orientations. The RCC probe produced results with a smaller standard deviation as a percentage of the ball burst strength compared with the CN probe with either orientation. Therefore the RCC probe should be used for the modified ball burst test within this study.

B.6 References

British Standards Institute. BS EN ISO 139:2005 Textiles — Standard atmospheres for conditioning and testing +A1:2011. 2005. BS EN ISO 139:2005.

British Standards Institute. BS EN ISO 9073-5:2008 Textiles — Test methods for nonwovens Part 5: Determination of resistance to mechanical penetration (ball burst procedure) (ISO 9073-5:2008). 2008. BS EN ISO 9073-5:2008.

Appendix C – Results (on CD)