



Engineering Water Efficiency Gains

Simon Walters

School of Computing, Engineering & Mathematics

University of Brighton

Direct phone: 01273 64 2233

Email: s.d.walters@brighton.ac.uk

10/12/2014

Dr. S. D. Walters, University of Brighton, UK

1

My Background

- Lecturer in Electrical and Electronic Engineering (and related subjects)
- Course Leader of Automotive Engineering Undergraduate Degrees
- Researcher in Electrical & Electronic, Automotive, & Computer Engineering
- Supervisor of a range of: PhD, MSc, MEng and BEng student projects

10/12/2014

Dr. S. D. Walters, University of Brighton, UK

2

“ICT for Water Efficiency”

- “The use of computers and other electronic equipment and systems to collect, store, use, and send data electronically” – Cambridge Business English Dictionary. [Cambridge University Press, 2014]
<http://dictionary.cambridge.org/dictionary/business-english/ict>.

Some Statistics on Domestic Water Usage

How you use water in your home

Toilet flushing	30%
Personal washing - baths and taps	21%
Personal washing - showers	12%
Clothes washing	13%
Washing up	8%
Outdoor	7%
Other	5%
Drinking	4%

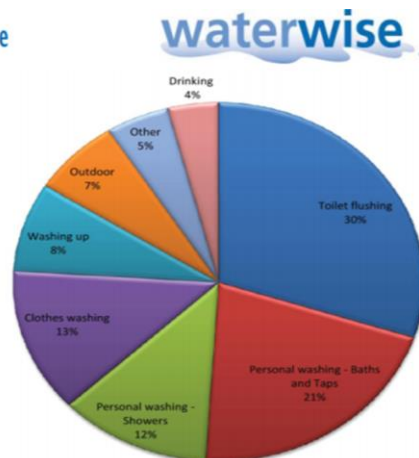

Average water use of a UK household [WaterWise, 2012]

Why is this Important?

- The data reveals:
 - There are categories of surprisingly high water usage
 - There are categories for further cutbacks in water usage
 - A large proportion of supplied water is unnecessarily clean

10/12/2014

Dr. S. D. Walters, University of Brighton, UK

5

What is Wrong with Existing Statistics?

- In the case of the discussed data...
- An amalgamation of data collected via the Waterwise Evidence Base, from:
 - Projects that have measured water use around the home, and
 - Information provided by WRC, UKWIR and water companies.
- Whilst interesting and informative, this data comes with “health warnings”:
 - The split within personal washing between baths & taps and showers is still being refined
 - Outdoor water use may vary from region to region
 - Historical data – currently a few years old – and habits and behavioural trends change
- ‘Some new measured data would be welcome’
- The EST pie chart is based upon data collected from the calculator jointly developed as part of a European funded project. It is self-reported data provided by self-selected participants, and so while more recent definitely needs to be handled carefully.

Source: [Jordan, 2014]

10/12/2014

Dr. S. D. Walters, University of Brighton, UK

6

Requirement for Capturing New Data

- Usage data (approximate flow, duration, user, time and date...)
- Points of test
 - Bathroom: basin, shower, toilet, bidet ...
 - Kitchen: sink, dishwasher, fridge, washing machine ...
 - Exterior: Outdoor tap ...
- In this example, NINE points to be concurrently monitored, in ONE domestic setting
- A large-scale test reasonably could involve TENS or HUNDREDS of domestic or industrial settings
- NEED: Cost-effective Sensing of Water Usage

10/12/2014

Dr. S. D. Walters, University of Brighton, UK

7

Cost-effective Sensing of Water Usage

Project Undertaken by: [Walters, 2012], and continued by: [Tayerera, 2014];
Another MEng group currently is looking into a related area of work

- The aim is for a study to be undertaken into a non-intrusive method of cheaply and reliably measuring water flow.
- The project will involve investigation of existing sensor technologies, laboratory testing of promising technologies and possible modifications for real-world applications.
- It will be necessary to consider means by which the data may be collected, centralised and sent to researchers.

10/12/2014

Dr. S. D. Walters, University of Brighton, UK

8

Scope of the Work

- Some existing sensor technologies
- A cost-effective sensor for mass deployment
- Testing using a hydraulic bench
- Optimisation of frequency response
- Electrical noise, amplification and filtering
- Packaging and local transmission of data
- Transmission and centralisation of collected data
- Parasitic power for remote sensors

10/12/2014

Dr. S. D. Walters, University of Brighton, UK

9

A Precision Flow Sensor



Test Instrument

'Sensor' pair



Principle of operation: transmission and reception of waves through the flowing medium, followed by calculation of the direction and magnitude of the flow volume.

10/12/2014

Dr. S. D. Walters, University of Brighton, UK

10

A Cost-effective Sensor



A piezo transducer
[Maplin, 2014]

Outline Requirements Specification

- ... must be mass-deployable
- ... must be non-intrusive
- ... must use a 'cheap' transducer (left upper figure)
- ... must be self-powered (Remember 'BS and Part P')
- ... must use almost no power



An RFID tag
[Maplin, 2014]

- ... ideally use 'parasitic' power generation
- ... ideally should allow 'user-identification' (left lower figure)
- ... ideally should be simple in operation

For the moment, ignore requirement to identify users
Also, assume that direction of flow is unimportant for the application in mind

A Sensor Test in the Home

Transducer mounted
on hot pipe
(Cold tap off)

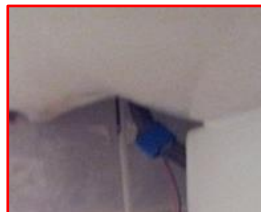
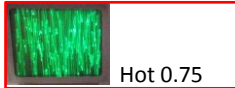
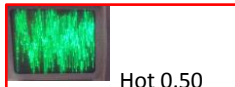

A sensor location:
At home.
Taped to pipe on top
of insulation tape

Oscilloscope settings:

Amplitude: Ch1 dc 5mV/division
Timebase: 1ms/division

Transducer mounted
on cold pipe
(Hot tap off)

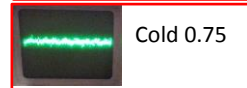

A Sensor Test in the Laboratory

v Hydraulic Bench with Sensors*

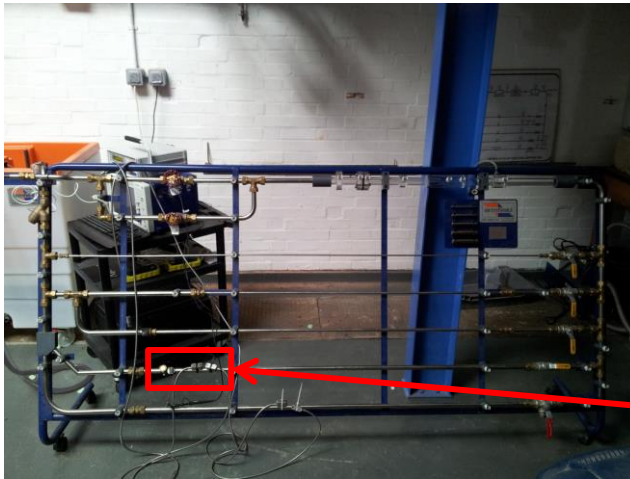

^ Reservoir and pump

Sensors:
L: Two piezo elements
R: Katronic 'sensors'

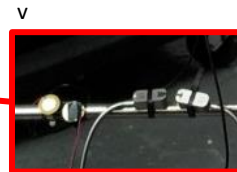

10/12/2014

Dr. S. D. Walters, University of Brighton, UK

13

Results of Laboratory Test

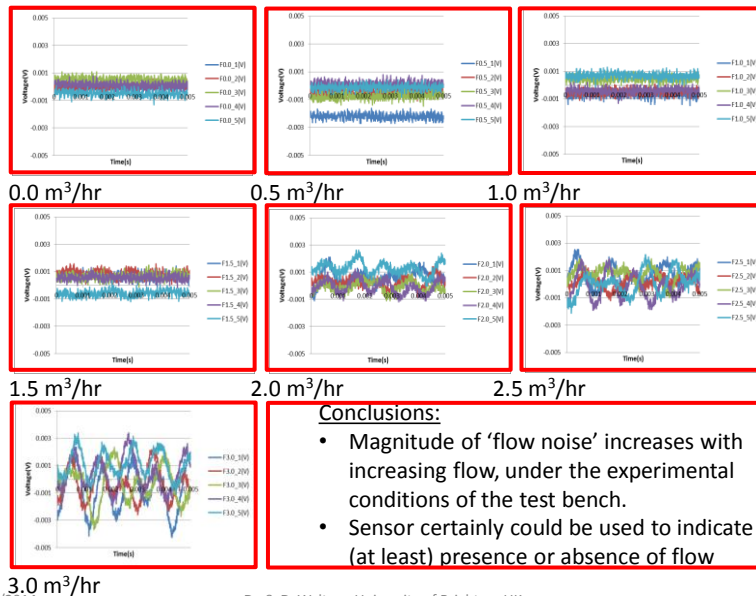

Conclusions:

- Magnitude of 'flow noise' increases with increasing flow, under the experimental conditions of the test bench.
- Sensor certainly could be used to indicate (at least) presence or absence of flow

10/12/2014

Dr. S. D. Walters, University of Brighton, UK

14

Optimization Issues of a Flow Sensor

- Having found a suitable transducer/sensor...
- Considering the case of a two-tap sink unit:
 - Which tap? (Use two flow sensors or one sensor with temperature transducer or further analysis)
 - Turbulent or laminar flow? (Test effect)
 - Hot or cold fluid? (Test effect)
 - Noise? (Filter/amplify, as required)
 - Precision? (NB Only if analogue signal needed)
 - Digital? (Simple off/on signal if not analogue)
 - Sensor calibration needed?
 - Further processing of data required (eg. Fourier [Awcock, 2008], [Tayerera, 2014])?
 - Source(s) of parasitic power

10/12/2014

Dr. S. D. Walters, University of Brighton, UK

15

Filtering and Amplification

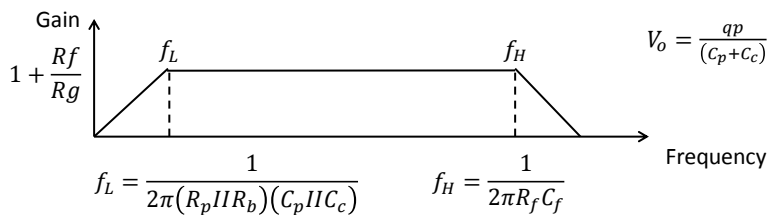
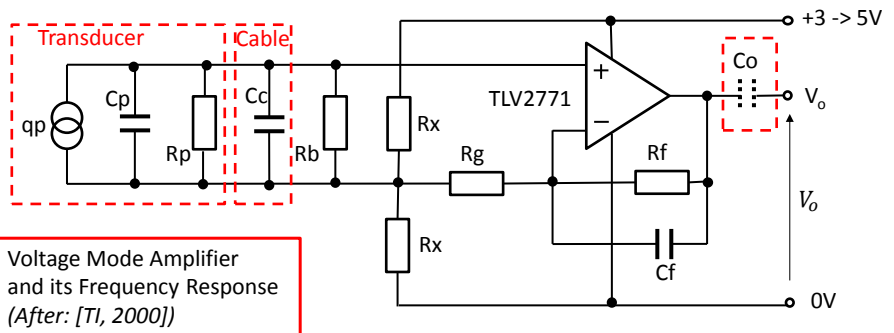

$$V_o = \frac{qp}{(C_p + C_c)} \cdot \left[1 + \frac{R_f}{R_g} \right] + \frac{V_{cc}}{2}$$

10/12/2014

Dr. S. D. Walters, University of Brighton, UK

16

Local and Mass Data Collection

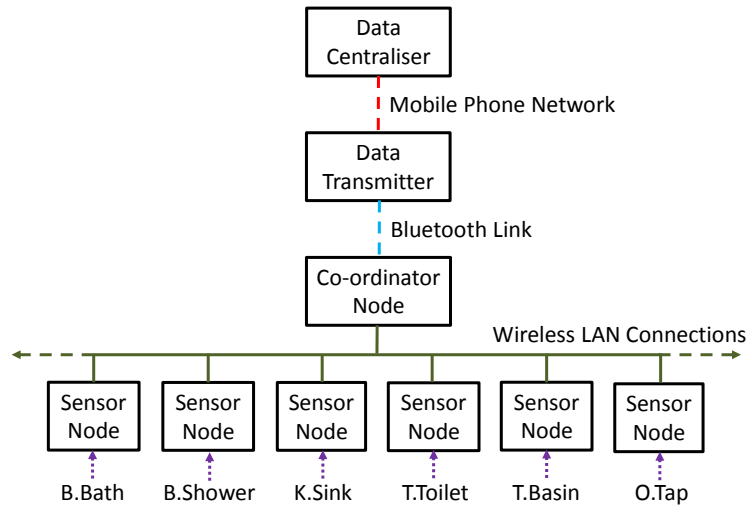

Inspired by: [Sangster, 2013]

10/12/2014

Dr. S. D. Walters, University of Brighton, UK

17

Co-ordinator Node (Co-ordinator Node)

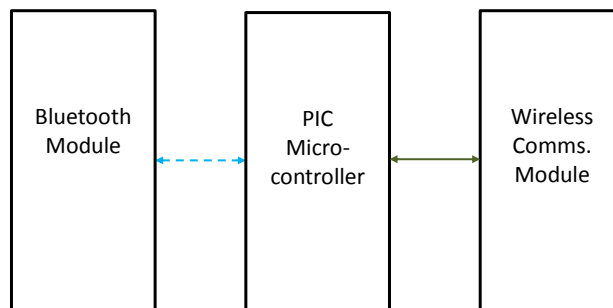

Inspired by: [Sangster, 2013]

10/12/2014

Dr. S. D. Walters, University of Brighton, UK

18

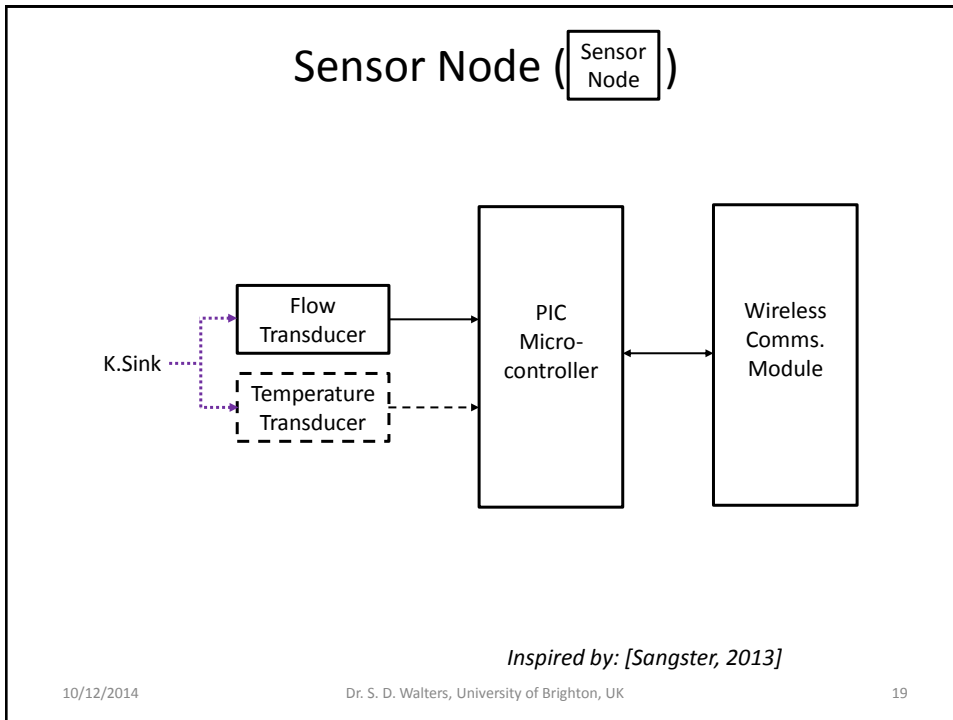

Boosting the Efficiency of Water Usage

Project Undertaken by: [Ashley et al., 2014]

- The student group will research and analyse the usage of water by the massed end-users.
- From this, various mechanical and electrical means of saving water resources will be thoroughly investigated, both in technical and financial terms.
- Where appropriate, new technologies and techniques will be analysed in depth and prototypes produced.
- Solutions for mass-adoption should be a priority.
- This project will be jointly supervised by Kemi Adeyeye in the School of the Environment and Technology.

Scope of the Work

- Grey-water applications and solutions
- Focus on home rainwater collection, storage and use
- Design, construction and testing of a ram-pump
- Parasitic water power for a pump
- Costing and breakeven studies
- Marketing

10/12/2014

Dr. S. D. Walters, University of Brighton, UK

21

Domestic Greywater Supply System

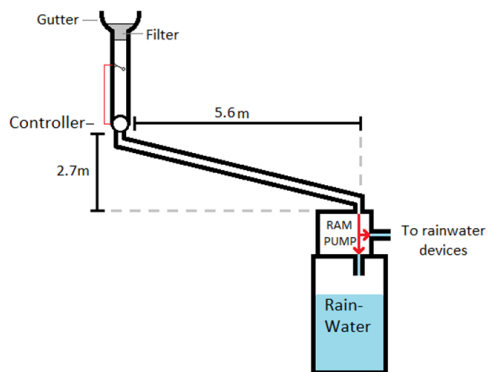

“The potential energy of two-thirds of the water is used to pump one-third to twice the original height” [Perkin, 2004].

(LH) Grey-water Supply System (RH) Prototype Ram Pump [Ashley et al., 2014]

10/12/2014

Dr. S. D. Walters, University of Brighton, UK

22

Controller

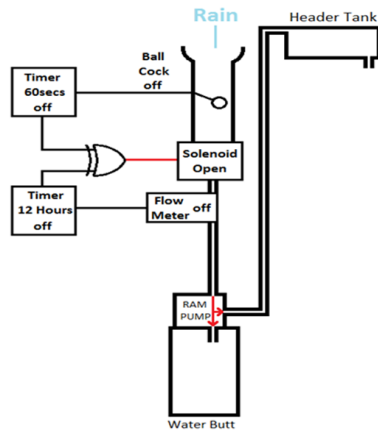

Operation Principle

1. Solenoid valve is open. Rain starts to fall.
2. First few (dirty) litres of water only trickle through to butt (without activating ram pump)
3. Higher flow rate triggers 12hr timer and shuts valve. Rainwater collects in temporary storage.
4. After 12hrs, solenoid valve is opened to use temporarily-stored water while still 'fresh'.
5. If temporary storage is full, ball cock triggers 30s timer. Solenoid valve opens feeding pump.
6. Once 30s time is up, valve closes for refilling of storage.
7. When a full store is discharged, flow meter restarts 12hr timer, avoiding loss of heavy rain.

Detail of electronic control system relative to external components
[Ashley et al., 2014]

10/12/2014

Dr. S. D. Walters, University of Brighton, UK

23

Features

- Collects, stores and pumps water from domestic guttering
- Allows water to be pumped up to elevated appliances
- Self-powered by the grey-water itself
- Costs £396.99 to make
- Projected to save £1.60 per month
- Payback = 11 years, 4 months

[Ashley et al., 2014]

10/12/2014

Dr. S. D. Walters, University of Brighton, UK

24

References

- [Ashley et al., 2014] "Boosting the Efficiency of Water Usage" (4th Year MEng Major Team Project) – by Jack Ashley, Theodoros Epaminonda, Stewart Kidd, Harry Murray-Rowley (2013-14), Supervised by Dr. S. D. Walters and Dr. N. Miche.
- [Awcock, 2008] "Investigations Into Time-Varying Signals And The Frequency Domain Using Excel or 'Let's Make a Spectrum Analyser Using Excel!' Parts 1 and 2", Graeme Awcock.
- [Bramston et al., 2014] "Development of a Non-invasive Water-metering Network at Domestic Level" (4th Year MEng Major Team Project) – by Ross Bramston, Declan Lowry, Josiah Jones, James Manuelyan, Cameron Hargreaves (2014-15).
- [Cambridge University Press, 2014] "Definition of ICT", Accessed online 2014, <http://dictionary.cambridge.org/dictionary/business-english/ict>.
- [Jordan, 2014] Private Email Communication with Dani Jordan, Director of Research and Delivery, Waterwise (www.waterwise.org.uk), 3/12/14.
- [Perkin, 2004] "Hydraulic Ram Pumps. The Industrial Heritage of Taunton Dane No.7", J. Perkin, 2004.
- [Sangster, 2013] "Smart Home System" (3rd Year MEng Individual Project) – by Neil Sangster (2012-13), Supervised by Dr. C. Garrett; Internally Examined by Dr. S. D. Walters.
- [Tayerera, 2014] "Cost Effective Sensing of Water Usage" (3rd Year MEng Individual Project) – by Tinashe Tayerera (2013-14), Supervised by Dr. S. D. Walters; Internally Examined by Dr. C. Garrett.
- [TI, 2000] "Signal Conditioning Piezoelectric Sensors", Application Report, By James Karki, Mixed Signal Products, Texas Instruments, September 2000.
- [Walters, 2012] "Cost Effective Sensing of Water Usage" Individual Research by Simon Walters (2012-13).
- [WaterWise, 2012] "Domestic Water Usage Statistics" from WaterWise Website, [Water_factsheet_2012.pdf](http://www.waterwise.org.uk/data/resources/25/Water_factsheet_2012.pdf), R. Millar, Accessed 02/12/2014, http://www.waterwise.org.uk/data/resources/25/Water_factsheet_2012.pdf.

10/12/2014

Dr. S. D. Walters, University of Brighton, UK

25

Acknowledgements

- Dr. Kemi Adeyeye
- Dr. Jon Gates – for the use of his precision flow meter
- The Hydraulics Lab staff and technicians (including Dr. Heidi Burgess)
- My students (see References/Appendix)
- My 'Mechanical' colleague on the MEng Major Team Projects, Dr. Nicolas Miche

10/12/2014

Dr. S. D. Walters, University of Brighton, UK

26

Appendix: Other MEng Water-related Projects

“Industrial Wireless Systems in the Water Industry” (3rd Year MEng Individual Project) – by Andrew Abdulmasih (2008-09). Supervised by Chris Knight (UoB) and Colin Cumming (Southern Water/4D).

“The Design Process for Lifecycle Analysis of Pumping Stations” (4th Year MEng Major Team Project) – by: Carl Gibson & Andrew Abdulmasih (2009-10). Supervised by Deshinder Singh Gill (UoB). EWI.

“Water and Energy – Linking the Benefits” (4th Year MEng Major Team Project) – by: James Ingram, Anthony Thomas, Sarah McGee, Matthew Reeves, Supervised by Dr. S. D. Walters and Dr. N. Miche. (2010-11) EWI.

“The Reduction of Southern Water’s Energy Costs” (4th Year MEng Major Team Project) – by: Louis Fox, Jack Price, Georgios Polyzois, Supervised by Dr. S. D. Walters and Dr. N. Miche. (2011-12) EWI.

“The Low Energy (Waste) Water Treatment Plant of the Future” (4th Year MEng Major Team Project) – by: Derrick Boame, Caleb Smart, Abiye Atamunotoru, Prince Finebone, Olaitan Ajimobi, Supervised by Dr. S. D. Walters and Dr. N. Miche. (2012-13) Costain.

“Intelligent Water System(s)” (4th Year MEng Major Team Project) – by: Mohiden Abdul Majeed Abdul Ahad, Alasdair Foster Anselm Browne, Thomas Vincent Court, Priesh Himansu Patel, Gilles Tchana Toffe, Supervised by Dr. S. D. Walters and Dr. N. Miche. (2012-13) EWI.

“Remote Monitoring Network (at Costain plc)” (4th Year MEng Major Team Project) – by: Oliver Buhlinger, Krzysztof Mlodozieniec, Martin Stevens, James Zafar, Dominic Zolkiewka, Supervised by Dr. S. D. Walters and Dr. N. Miche. (2012-13) Costain.

Thank you for your attention

Contact Details:

Dr. Simon D. Walters MIET, CEng
 School of Computing, Engineering & Mathematics
 University of Brighton
 Direct phone: 01273 64 2233
 Email: s.d.walters@brighton.ac.uk
 Web: <http://about.brighton.ac.uk/cem/contact/details.php?uid=sdw>