

**ENERGY EFFICIENT
INDUSTRIALIZED HOUSING
RESEARCH PROGRAM**

**SUMMARY
FY 1994 RESEARCH ACTIVITIES**

**UNIVERSITY OF OREGON
AND
UNIVERSITY OF CENTRAL FLORIDA**

**ENERGY EFFICIENT INDUSTRIALIZED HOUSING
RESEARCH PROGRAM**

SUMMARY OF FY 1994 RESEARCH ACTIVITIES

**Center for Housing Innovation
University of Oregon
Eugene, Oregon 97403-1206**

**Contact:
G.Z. (Charlie) Brown
(503) 346-5647**

**and
Florida Solar Energy Center
a Research Institute of
the University of Central Florida
300 State Road 401
Cape Canaveral, Florida 32920-4099**

**Contact:
Subrato Chandra
(407) 823-0250**

**Department of Industrial Engineering
University of Central Florida
4000 Central Florida Blvd.
Orlando, Florida 32816**

**Contact:
Mike Mullens
(407) 823-5703**

U.S. Department of Energy Contract No. DE-FC51-94R020277

July 1995

AUTHORS

Center for Housing Innovation University of Oregon

Kevin Aires	Research Assistant
Rudy Berg	Senior Research Assistant
G.Z. Brown	Project Director, Professor
Michele Helou	Graduate Research Fellow
Jeff Kline	Senior Research Assistant
Pawan Kumar	Graduate Research Fellow
Paul Larocque	Graduate Research Fellow
Marie Raney	Senior Research Assistant
Tomoko Sekiguchi	Research Associate

Florida Solar Energy Center University of Central Florida

David Beal	Research Engineer
Subrato Chandra	Director of Research and Development Division
Armin Rudd	Senior Research Engineer

Department of Industrial Engineering And Management Systems University of Central Florida

Robert Armacost	Assistant Professor
Tom Gawlik	Graduate Research Assistant
Mag Malek	Graduate Research Assistant
Mike Mullens	Assistant Professor
Mats Rheborg	Graduate Research Assistant

CONTENTS

	Page
1.0 EXECUTIVE SUMMARY	1
2.0 INTRODUCTION	3
3.0 DEFINITIONS	5
4.0 STRESSED SKIN INSULATING CORE PANEL COMPONENTS	9
5.0 INCORPORATION OF ENERGY ANALYSES INTO CAD SOFTWARE	15
6.0 MANUFACTURING PROCESS AUTOMATION AND SIMULATION	21
7.0 FIELD TESTING OF WHOLE HOUSES AND COMPONENTS	27
8.0 ENERGY MONITORING	33
9.0 SPIRIT OF TODAY HOUSES	39
10.0 PROCESS AND ENERGY EFFICIENCY REVIEWS (PEERS)	45
11.0 FY 94 PUBLICATIONS	47
12.0 ACKNOWLEDGEMENTS	49

1.0 EXECUTIVE SUMMARY

This report summarizes research results from March 1994 to February 1995 for the Energy Efficient Industrialized Housing Research Program.

One research focus area of Stressed Skin Insulating Core (SSIC) panel technology is of interest because SSIC panels reduce thermal bridging and infiltration. Using several innovations developed as part of this project a SSIC panel house was constructed and compared to a very efficient conventionally constructed house of the same design. Cost analysis studies show that the SSIC panel house has a lower first cost in most locations and provides increased profit to the builder because of reduced construction time. Thermal testing has confirmed that the house is as energy efficient as designed. In a related project a design for an on-grade SSIC panel floor was developed that promises to have better thermal performance and lower first cost than other floor/foundation systems.

Energy analysis computer software has been developed with and marketed by Softdesk, Inc. that is incorporated directly in a CAD system. This is important because when geometric data is taken directly from the CAD program it doesn't have to be re-entered as is the case with other energy analysis software, thereby reducing errors, reducing analysis time requirements, and making energy design more a part of the normal architectural design process. Another program has been developed for SSIC panel producers that reduces the time it takes to do cost quotes from as much as eight hours to as little as 30 minutes and incorporates an energy analysis enabling sales personnel to more efficiently sell the energy features of their products. A key to convincing manufacturers to try energy efficient ideas is to convince them that the proposed design changes will not reduce their production efficiency. We have developed software that enables manufacturers to see the impact of design changes on the production process before making costly production changes. The first field test of the software modeled an automated frame panel line. Implementation of recommendations by the panelizer led to an 8% increase in production rate with no increase in labor. We are also developing a laboratory to test the constructability of homebuilding component systems. Simulations and laboratory experiments combined with field data will enable us to determine the optimum mix of manufacturing and site

construction to increase energy efficiency and reduce cost. As part of this program we have completed a number of field studies of innovative components.

We have completed a number of component and whole house tests. In our roof testing facilities we have shown that certain tile configurations reduce heat transfer through the roof by as much as 48%. We have tested two innovative commercially available concrete construction systems and analyzed their ability to reduce or shift peak loads and to reduce annual energy use. Several suggestions were made to the manufacturers that will enable them to improve the energy performance of their products. Thermal testing was completed on six units of housing which was constructed using three types of panelization. The test data indicates that closed panel and SSIC panel construction perform better than open panel construction where insulation and vapor retarders are installed in the field rather than the factory.

The Spirit of Today House was completed and featured in *Better Homes and Gardens* in October, 1994. The house shows how energy features are compatible with mainstream residential construction and demonstrates additional features that are becoming important to the consumer such as handicapped accessibility and excellent indoor air quality.

The United States' housing industry is undergoing a metamorphosis from hand-built to factory-built products. Virtually all new housing incorporates manufactured components; indeed, an increasing percentage is totally assembled in a factory. The factory-built process offers the promise of houses that are more energy efficient, of higher quality, and less costly. To ensure that this promise can be met, the U.S. industry must begin to develop and use new technologies, new design strategies, and new industrial processes. However, the current fragmentation of the industry makes research by individual companies prohibitively expensive and retards innovation.

This research program addresses the need to increase the energy efficiency of industrialized housing. Two universities have responsibility for the program: the University of Oregon (UO) and the University of Central Florida (UCF). Together, these organizations provide complementary architectural, energy, systems engineering, computer science and industrial engineering capabilities.

The research program focuses on three interdependent concerns: (1) energy use, (2) industrial process, and (3) housing design. Building homes in a factory offers the opportunity to increase energy efficiency through the use of new materials and processes, and to increase the value of these homes by improving the quality of their construction. Our work in housing design strives to ensure that these technically advanced homes are marketable and will meet the needs of the people who will live in them.

Energy efficiency is the focus of the research, but it is always viewed within the context of production and design. This approach enables researchers to solve energy problems in ways that can help industry improve its product. These improved products will help U.S. companies compete with foreign companies which would alleviate the trade imbalance in construction products, will increase the productivity of the U.S. housing industry, and will decrease both the cost of housing and the use of fossil fuels, which are expensive and damaging to the environment.

3.0 DEFINITIONS

Of the many definitions currently used to describe industrialized housing, we have selected four:

- (1) **HUD code** houses (mobile homes)
- (2) **modular** houses
- (3) **panelized** houses (including domes, precuts, and log houses)
- (4) **production-built** houses (including those that use only a few industrialized parts).

These four definitions were selected because they are the categories used to collect statistical data, and so are likely to persist. However, the categories are confusing because they are based on a mix of characteristics: unit of construction (modular, panelized), method of construction (production-built), material (panelized), and governing code (HUD Code).

There are other ways to categorize industrialized housing, each of which provides a different perspective on the energy use. Japan and Sweden, for example, define industrialized housing in terms of corporate structure. Industrialized housing is equated with home building companies. These companies vertically integrate or have under one roof all or most of the housing process, including raw material processing, component assembly, house construction, installation, financing, marketing, and land development. This definition is useful because it addresses the extent of control a given company has over the design, production, and marketing of the house, and therefore over its energy use.

Other definitions can shed light on important aspects of industrialization and enable us to predict the impact of innovations, establish priorities for research activities, and identify targets for information. For example, industrialized housing can also be defined as using open or closed systems. A closed system, which limits design alternatives, has the potential to benefit its supplier because it is exclusive. An open system, by contrast, is more tolerant of a wide range of designs and gives the home owner a range of component choices and the opportunity to purchase these components in a more competitive market place.

Other important ways of categorizing include: 1) the level of technology employed --high, intermediate, or low; 2) the percentage of value that can be supplied by the home owner, using sweat equity; 3) the physical size of the elements-- components, panels, cores, modules, or complete units.

HUD Code Houses

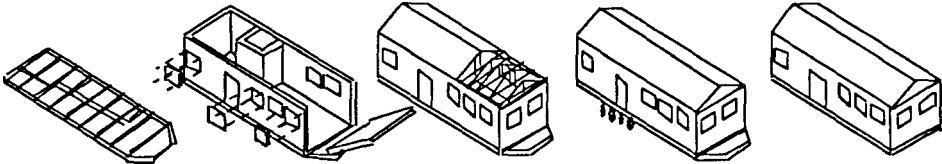

**Figure 3 - 1
HUD Code House**

A HUD code house is a movable or mobile dwelling constructed for year-round living, manufactured to the preemptive Manufactured Housing Construction and Safety Standard of 1974. Each unit is manufactured and towed on its own chassis, then connected to a foundation and utilities on site. A HUD code house can consist of one, two, or more units, each of which is shipped separately but designed to be joined as one unit at the site. Individual units and parts of units may be folded, collapsed or telescoped during shipment to the site.

Modular Houses

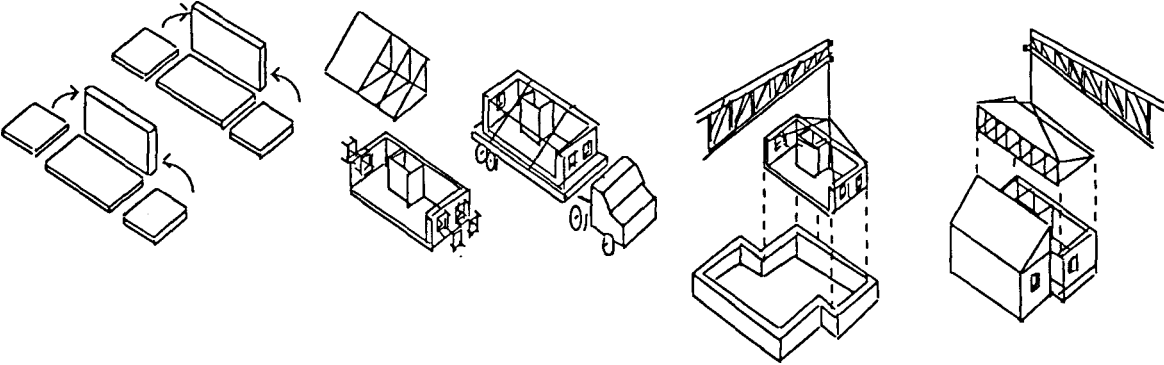

**Figure 3 - 2
Modular House**

Modular housing is built from self-supporting, three-dimensional house sections intended to be assembled as whole houses. Modules may be stacked to make multistory structures and/or attached in rows. Modular houses are permanently attached to foundations and comply with local building codes.

Panelized Houses

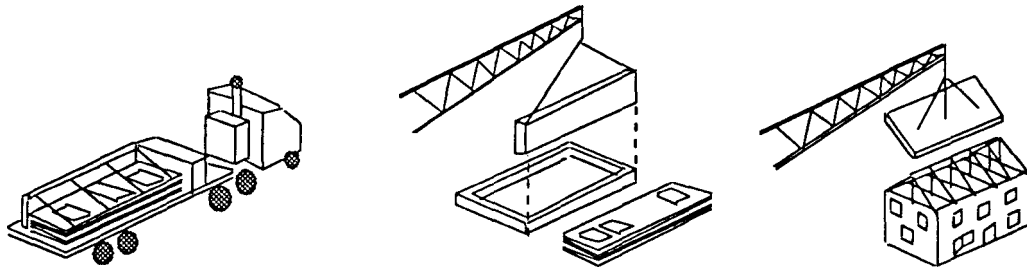

**Figure 3 - 3
Panelized House**

Panelized houses are whole houses built from manufactured roof, floor and wall panels designed for assembly after delivery to a site. Within this category are several sub-categories. *Framed panels* are typically stick-framed, carrying structural loads through a frame as well as the sheathing. *Open-framed panels* are sheathed on the exterior only and completed on site with interior finishes and electrical and mechanical systems. *Closed-framed panels* are sheathed on both the exterior and interior and are often pre-wired, insulated and plumbed. *Stressed-skin panels* are often foam filled, carrying structural loads in the sheathing layers of the panel only.

Production-Built Houses

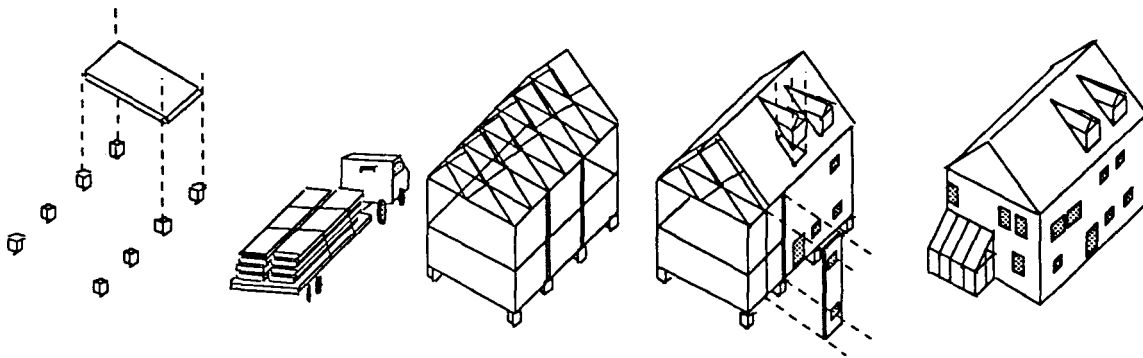

Figure 3 - 4
Production-Built House

Production building refers to the mass production of whole houses “in situ.” This large and influential industry segment is industrialized in the sense that it employs rationalized and integrated management, scheduling, and production processes, as well as factory-made components. In this instance, however, rather than the house being built in the factory and moved to the site the factory is the building site, which becomes an open-air assembly line through which industrialized labor and materials move.

This section describes two projects—a cost analysis of the Stressed Skin Insulating Core (SSIC) Panel Demonstration House and the design of an on-grade SSIC panel floor/ foundation system. There is also a description of the SSIC Panel Demonstration House thermal testing in section 8.0 on energy testing in this report.

Cost Analysis

This study evaluated the cost of the building system innovations of the SSIC Panel Demonstration House - Springfield I. This house was constructed and its construction process documented in 1994. The objective was to determine the cost of the building envelope as compared to a conventionally built, architecturally equivalent reference house designed to the same energy standards, which were 40% better than the Oregon code.



Figure 4 - 1, Stressed Skin Insulating Core Panel Demonstration House from the South West

The Demonstration House proved to have a lower first cost if built in many locations and to be 14% more profitable to the builder than the Reference House. The primary cost benefit of the Demonstration House is the reduced amount of on-site labor required through the use of SSIC panels. In addition to providing high insulation values and a very tight building envelope, these panels reduce the use of framing lumber by almost 50%. The total on-site labor hours required to assemble the envelope system are estimated to be 52% more for the Reference House than the Demonstration House, which means that labor rates have a critical effect on the total cost difference. Also important are panel costs, which represent 34% for the total cost of the Demonstration House envelope. As this market grows and spreads more evenly across the country, panel prices are predicted to increase at a slower rate than other building materials.

Figure 4-2 illustrates the total envelope cost differences as based on *Means* cost data and panel price surveys. Not included in these cost results are the increased profit benefit garnered from the faster production rate of the Demonstration House. The shorter construction time translates into increased profit potential for the contractor or developer as more houses with nearly the same profit gain can be built in a single year. If we assume that completing the remainder of each house takes 50 days and adds another \$60,000 in cost, then based on a 10% profit margin and a sequential building cycle, a 14% increase in yearly profit benefit accrues to the builder of Demonstration House system houses.

Stressed Skin Insulating Core On-grade Floor and Foundation System

One of the beneficial products of the Stressed Skin Insulating Core Panel Demonstration House project was an idea for an on-grade insulated panel floor and foundation system. We sponsored a focus group composed of SSIC panel producers, builders, and material and component suppliers. This group identified eight areas of potential innovation in SSIC panels and ranked the on-grade panel system as the most promising.

The on-grade floor system incorporates foundation, perimeter drains, moisture barrier, insulation, wiring chase and structural floor (figure 4-3). It is designed to be built in one day, without concrete specialty trades.

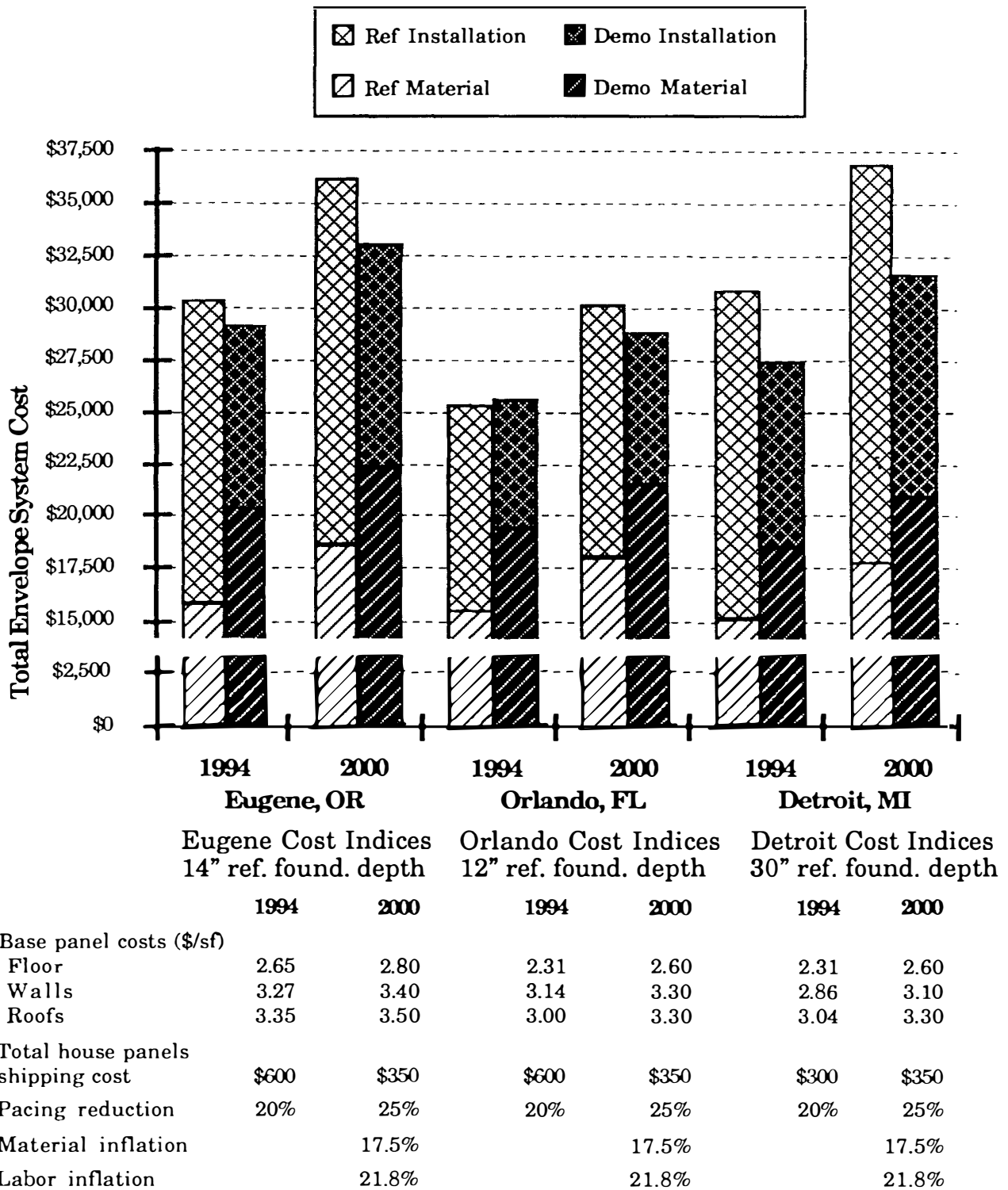

Figure 4 - 2
Comparison of Total Envelope Costs for Two House Systems
Based on Present and Future Scenarios

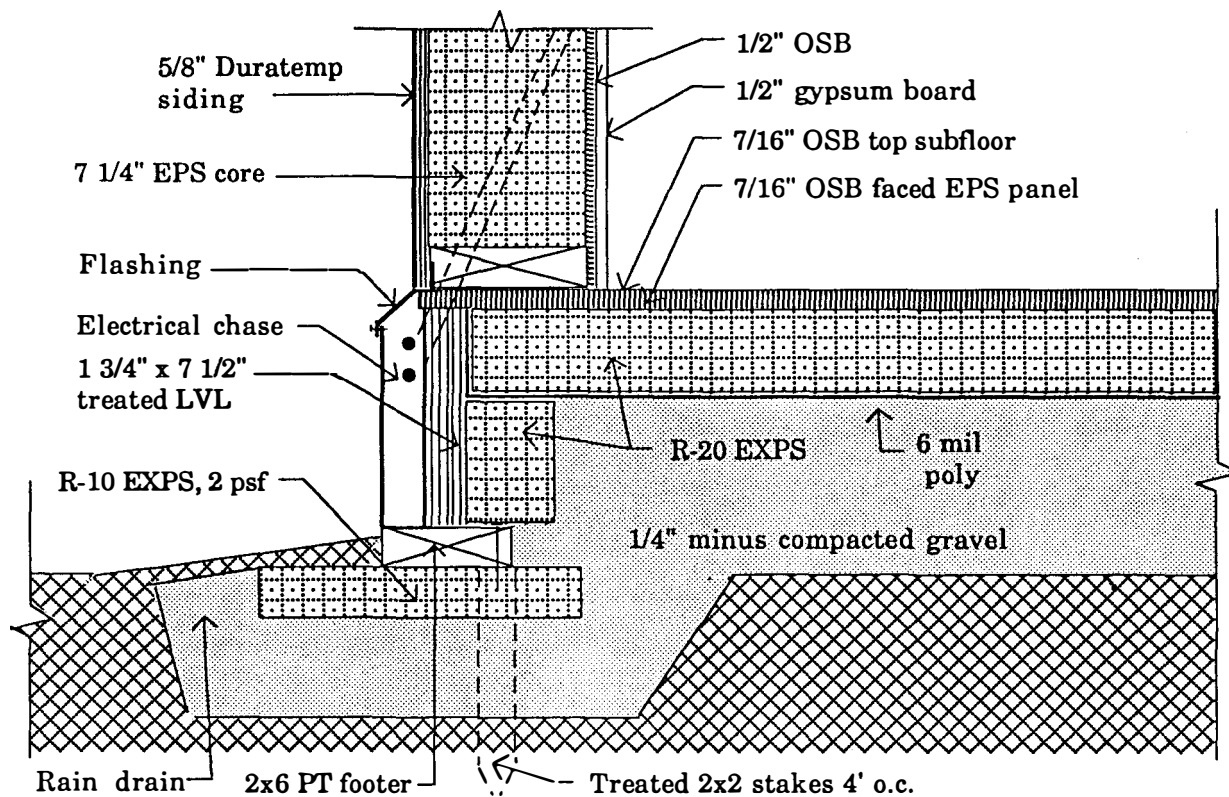

Figure 4-3, SSIC On-Grade Floor System

For cost study purposes the floor design details were developed for the 20' x 36' SSIC Demonstration House design. The floor's estimated cost (for four variations) is compared to that of an insulated concrete slab floor, a panel plenum floor, the panel and pier-based Demonstration House floor, and the floor of a similar but conventionally framed Reference House. The cost estimates for these systems are summarized in figure 4-4.

<u>System</u>	<u>Floor and Foundation Cost</u>
On-grade with trenched, foam footer	\$4015
On-grade slab with trenched footing	\$4354
On-grade (no trench) with site-built footer	\$4481
On-grade (no trench) with prefab LVL footer	\$4673
Insulated concrete slab	\$4775
Panel plenum floor	\$6813
Demonstration House	\$7206
Reference House	\$7465

Figure 4-4, Floor Cost Estimate

The cost advantage of an on-grade floor over concrete slab floors would be magnified if hardwood finish floor costs were included. With the concrete slab, treated sleepers or a “floating floor” system would have to be employed, while the panel slab would permit nailing the hardwood floor directly to the panel surface. However, the projected total house cost *savings* for both of the concrete and panel slab floors would be about \$250 additional compared to the costs for the Demonstration and Reference Houses, whose elevated crawl space design necessarily involves raised porches, entry stairs and handrails, plus related finishing costs.

Preliminary examinations and cost studies suggest that the on-grade panel floor offers improvements over other systems in construction speed at a competitive cost. Three recognized needs in U. S. housing are reduced cost (including reduced construction time), improved energy performance, and improved accessibility. The on-grade panel floor appears to address these three needs while offering marketability — resilience, warmth and compatibility with a variety of floor finishes including hardwood. In addition, house structural requirements due to wind loads are minimized, and siting opportunities are expanded because the lower house profile reduces solar impact on neighboring lots. A test program will determine whether these advantages of the panel slab floor can be verified in practice.

5.0 INCORPORATION OF ENERGY ANALYSES INTO CAD SOFTWARE

Two projects are reviewed in this section. The first, Softdesk Energy, describes the creation of an energy analysis module that is integrated into a commercial CAD System. The second project, *SIP Scheming* describes an energy analysis program designed specifically for stressed skin insulating core panel manufacturers.

Softdesk Energy

The objective of this task was to develop an energy analysis program that would encourage architects, builders, and housing manufacturers to improve the energy efficiency of their buildings. In order for these kinds of designers to readily attempt energy-efficient designs, several things must be true:

- The analysis must be done early enough that design changes are feasible.
- The energy program should work within the user's normal design environment.
- Accurate data about the building should be available.
- The interface should be easy to use, highly visual, and nontechnical with respect to energy.

Embedding our energy analysis within Softdesk's Auto Architect, which uses an AutoCAD system (the largest selling PC CAD program), enabled us to meet the first three criteria. The fourth criteria required an interface that encourages visual input of data as well as the more common visual output of results in graphic form. We have succeeded in creating an interface that requires no numeric input, reports results graphically, and begins to develop the user's intuitions about energy efficiency.

The vehicle for this project was a collaboration between industry, government, and academia, represented respectively by Softdesk, in Henniker, New Hampshire; Pacific-Northwest Labs (PNL), in Richland, Washington; and the University of Oregon. The Collaborative Research and Development Agreement (CRADA) was signed by the three groups in late 1992.

The product has three major parts: geometry interpretation, input of non-geometric data, and calculation and presentation of results. All three parts are oriented toward making energy analysis visual and nontechnical.

The geometry interpreter is a tremendous labor saver for the user. Most energy analysis programs require that the user type in the geometric features (length, area, pitch and thickness) of all energy elements – walls, windows, floors, roofs. However, this is information that the user has already indicated graphically in a CAD system. So in this tool the geometry interpreter scans the drawing and determines these parameters automatically, saving the user typing and preventing errors and inaccuracies. The user is then given visual feedback about what was interpreted.

Other, non-geometric data is input by the user through a series of dialog boxes. Although a mechanical engineer may be content to specify a building in terms of BTUs per square foot, most architects, builders, and manufacturers think of the spaces in terms of their functions or physical configurations. In our tool, the user picks wall types by looking at drawings of typical wall sections, then the tool reports an R-value. Likewise the user selects an activity, and the tool reports the BTUs per hour per person.

The third major part of the tool is the graphic report of the energy analysis results. When the user requests results, a bar graph is drawn on the CAD work area depicting the heat load or loss due to each building component for each month of the year in the selected climate. Examination of this graph quickly shows the user what component is causing the greatest problem, and whether there is a general heating problem or a cooling problem. Several graphs can be displayed at once, allowing the user to compare the energy impact of different design choices.

This tool was commercially released by Softdesk in May, 1995 (see figure 5-1.)

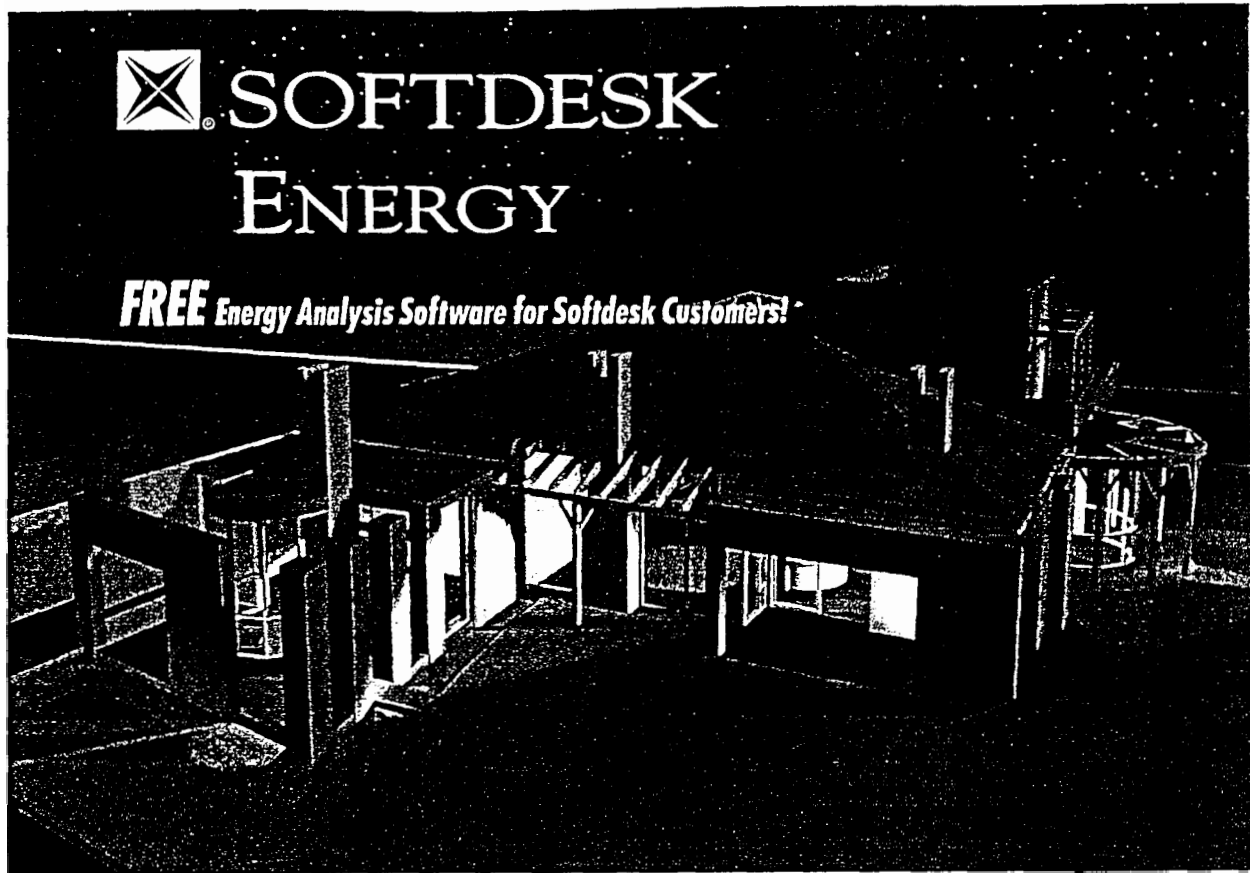

SOFTDESK ENERGY

FREE Energy Analysis Software for Softdesk Customers!

An easy way to design more energy efficient buildings

To help professionals design more energy efficient buildings and comply with new energy codes, Softdesk presents Softdesk® Energy software — FREE to Softdesk architectural customers. Easy-to-use Softdesk Energy is designed to help architects and engineers make energy-conscious decisions when they can have the most influence on savings. Softdesk Energy can be used at any point during the design process once the outside perimeter of the building has been defined.

Softdesk Energy is part of the U.S. Department of Energy (DOE) Design Tools Program. The software was developed in partnership with the Pacific Northwest Laboratory (PNL), the University of Oregon, and Softdesk through a Collaborative Research and Development Agreement sponsored by the U.S. Department of Energy.

In the spirit of this collaborative project, Softdesk is offering Softdesk Energy software FREE to all registered customers of Softdesk Auto-Architect® or Building Base software. Simply complete the registration form on the other side and mail it to Softdesk. Start designing more energy conscious buildings today!

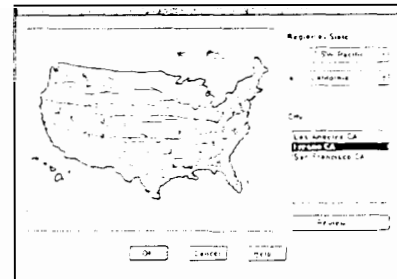

Clear graphics help architects and engineers see the impact their designs have on energy use.

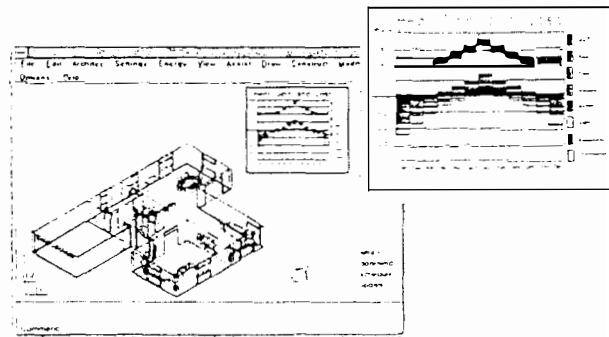
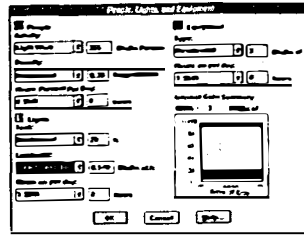

Figure 5-1, Softdesk Energy Auto-Architect flyer

SOFTDESK ENERGY

FREE Energy Analysis Software for Softdesk Customers!



Calculates Energy Loads

- Based on well-known ASHRAE Simplified Energy Analysis Method (SEAM)
- Determines energy use impact from internal factors, such as lighting needs, temperature, humidity, ventilation, and how the building is used
- Loads calculations available early in schematic design or later for completed-detailed design
- Detailed text reports and graphic results of heating and cooling loads
- Simple calculation of loads with minimal data entry
- Lighting levels for internal gains can be specified by selecting the type of activity performed in the space and the lighting type desired

Graphics

- Dialogue boxes present options in familiar architectural terminology
- Climates for geographic areas can be reviewed by picking a city or zone on a graphic map
- Generates charts of heating and cooling loads throughout the year based on the average temperature and humidity for a typical day in each month
- Color coding identifies how much each component contributes to total loads
- After non-geometric building characteristics are specified, loads are calculated and displayed graphically by month of the year and building component

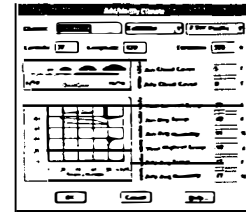

Easy to use

- Obtain energy results any time during design
- Simple graphic dialog driven data entry
- Geometry automatically transferred from architectural drawing to Softdesk Energy
- Fully integrated with Softdesk Auto-Architect and Building Base

Customized Results

- Select from 58 climactic locations or add your own climate data
- Specify walls, windows, doors, roofs, and foundations
- Specify building-specific internal loads from people, lights, and equipment

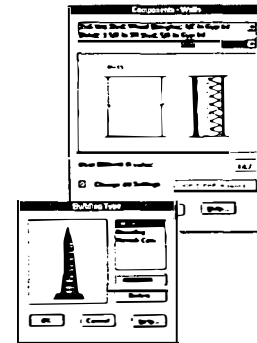

YES! I would like a FREE copy of Softdesk Energy!

Please complete this form and fax or mail it to Softdesk.

Name _____
 Title _____
 Company _____
 Telephone _____ FAX _____
 Address _____
 City _____ State _____
 Zip Code _____ Country _____

Auto-Architect Serial Number _____

Size of Your Firm 1-5 5-25 25-75 75+

Other energy analysis software currently in use at your company?

Yes, I am willing to participate in a follow-up survey on Softdesk Energy

SKU Code 07ENSPEC

The Softdesk Logo, Softdesk, and The Auto-Architect are registered in the U.S. Patent and Trademark Office and other products made by Softdesk, Inc. AutoCAD is registered in the U.S. Patent and Trademark Office by Autodesk, Inc. All other company names and product names are the property of their respective owners. Copyright © 1995 by Softdesk, Inc. All Rights Reserved.

SOFTDESK

SOFTDESK CORPORATE HEADQUARTERS
 7 Liberty Hill Rd. Henniker, NH 03242 USA
 Tel: 603-428-3199 Fax: 603-428-7901

Figure 5-1 (continued), Softdesk Energy Auto-Architect flyer

SIP Scheming

SIP Scheming is energy analysis and cost estimating software specifically designed for stressed skin insulating core panel producers. Cost quotes are typically done by hand and require as much as eight hours to complete, and only one in twenty quotes results in a sale. *SIP Scheming* is intended to facilitate marketing, sales, and production processes by integrating cost estimating and exporting to CAD while also providing energy feedback.

SIP Scheming's graphic input and output was designed for non-computer people, which makes *SIP Scheming* ideal for marketing and sales of SSIC panels. Drawings are input by scanning, by importing from a CAD program, or by drawing directly in *SIP Scheming*. A digital tape measure is then used to graphically “takeoff” areas by tracing over the drawings, so that within a matter of minutes an energy analysis and cost estimate is calculated. The program will calculate thermal loads for both panel and non-panel buildings.

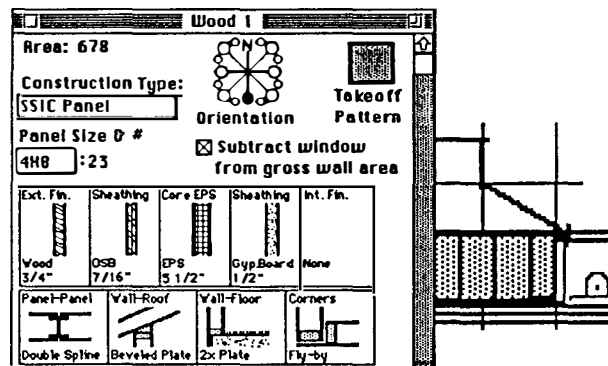

Figure 5-2
Takeoff Tape Measure and Specification Window

The results of the calculations are displayed in bar graphs. This makes it easy for nontechnical personnel or clients to understand the building's performance. The results include the effects of conduction, solar radiation, internal gains, ventilation, daylighting and mass.

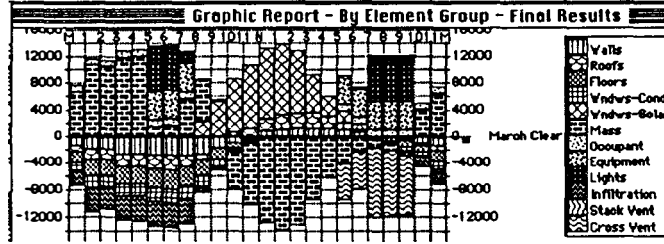

Figure 5-3
Energy Performance Graph

After completing an energy analysis, SSIC panel manufacturers can request a cost estimate. A Microsoft Excel spreadsheet is created detailing panels and connections used. The use of *SIP Scheming* has the potential to reduce quote time to 30 minutes, thus substantially reducing a manufacturer's sales overhead.

SIP Scheming 1.0 Cost Estimate		6-APR-94	11:47 a.m.	
4 Room House				
PANEL DESCRIPTION	PANEL SIZE	# PANELS	\$/SF	ITEM TOTAL
Walls				
OSB 7/16", EPS 5 1/2", OSB 7/16"	8'4"x8'	50	1.54	2464.00
Floors				
OSB 7/16", EPS 7 1/4", OSB 7/16"	4'x12'	42	1.31	2640.96

Figure 5-4
Cost Estimate Spreadsheet

Once a sale is made, building geometry information can be exported to ArchiCAD, a powerful 3D CAD package created by Graphisoft. This gives the manufacturer a head start on design development and shop drawings. If a more detailed energy analysis is desired, *SIP Scheming* can also create an input file for DOE 2, a more sophisticated energy analysis program.

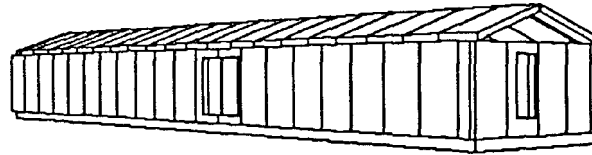

Figure 5-5
Perspective Drawing Done in ArchiCAD

SIP Scheming is currently being Beta tested by panel manufacturers.

6.0 MANUFACTURING PROCESS AUTOMATION AND SIMULATION

This section describes three projects: software to simulate the home manufacturing process, a study to determine the optimum mix of in-plant and site construction, and a study of concrete homebuilding components.

Generic (GIHMS) and Extended Generic Industrialized Housing Manufacturing (XGIHMS) Simulators

The objective of this task is to develop a Computer Aided Engineering (CAE) modeling tool that can assist housing manufacturers (both existing and new entrants) in planning and evaluating innovative manufacturing technologies. The Generic Industrialized Housing Manufacturing Simulator (GIHMS) integrates computer simulation, animation, and data base technologies to address these issues.



Figure 6-1, Extruder Station on Makron Wall Panel Line

In FY94 GIHMS technology was field tested at Glaize Components, a high-volume wood frame homebuilding component manufacturer in Winchester, Virginia. Glaize recently purchased the first Makron Wall Panel Line. The line is a true CAD/CAM flexible manufacturing system. COMSOFT Wall Builder CAD software is linked by local area network to the line's programmable logic controller, which drives both assembly and material handling equipment. The line's computer integration and cost-effective automation combine to provide square and accurate framing in a highly efficient, paperless, continuous

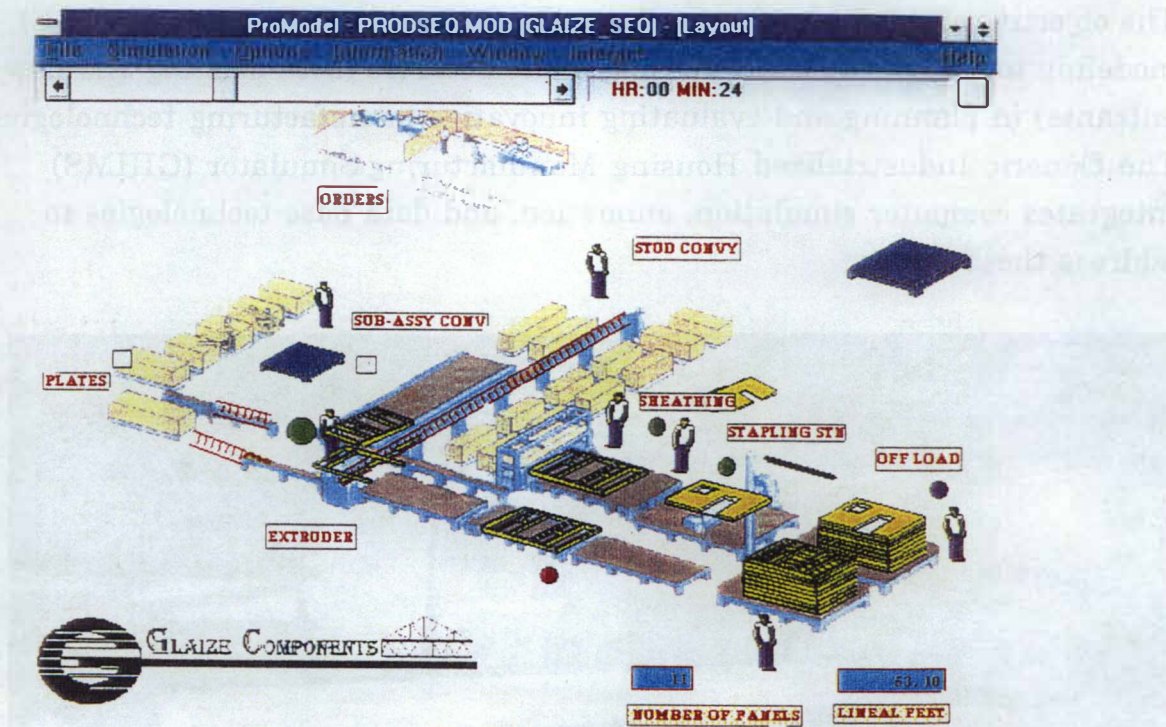

Figure 6-2, Computer Simulation of Makron Wall Panel Line

production operation. The line's extruder station is shown in figure 6-1. As is common with new, highly integrated manufacturing systems, the line experienced start-up problems. While most have been resolved, the system has yet to reach expected capacity.

The Energy Efficient Industrialized Housing (EEIH) team used GIHMS concepts to model the new line in hopes of improving capacity. The resulting computer animation is shown in figure 6-2. Simulation results suggested that line capacity

could be increased 8% by introducing a simple production scheduling scheme to smooth flow on the line. Since implementing the change, Glaize has experienced a 7 – 10 % increase in line capacity, with minimal increase in labor. Glaize management has repeatedly stressed that the simulation model would have been extremely valuable early in the design of the new line. A summary of the Glaize modeling effort will appear in the August 1995 issue of *Automated Builder* magazine.

The EEIH team also investigated extending GIHMS concepts to the construction site. A literature search of construction simulators was performed and results summarized. The primary finding was that although it is feasible to develop a construction simulator for housing, it will be much more difficult than for manufacturing, since construction site operations are inherently less structured than factory operations. This finding supported the conclusion that other approaches may be more effective in assessing the impact of design and process improvements on construction site operations. This is discussed in “Optimum Manufacturing Content.”

Optimum Manufacturing Content

The objective of this task is to address the issue of where and how to add value in home construction to maximize product quality/performance and minimize cost.

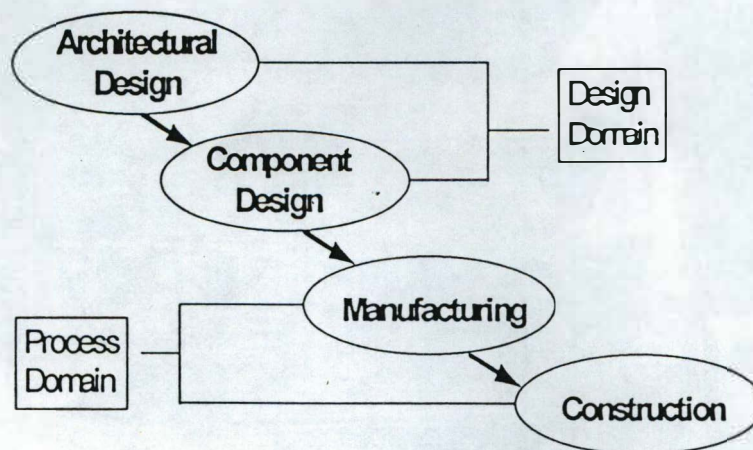

Figure 6-3, Scope of Homebuilding Constructibility

During FY94 we concentrated on developing an overall strategy for applying industrial engineering technologies to homebuilding. In summary, we concluded that a key role of the industrial engineer in homebuilding is to assess and improve homebuilding constructibility. Constructibility has been defined as “the extent to which the design of a building facilitates ease of construction, subject to the overall requirement for the completed building.” Key measures of constructibility include cost, schedule, safety and quality. The scope of constructibility (figure 6-3) starts with the architectural design of the home and ends with the completion of construction at the site. Note that constructibility addresses both the design and process domains and must include both the design and manufacture of building components.

Early efforts by the EEIH project team focused on improving manufacturing process efficiency. GIHMS simulator technology was developed and used to assess manufacturing process improvements. On the construction site the EEIH team benchmarked the constructibility of several innovative technologies, including structural insulated panels, the MIT roof system (figure 6-4), and



Figure 6-4, MIT Roof System Construction on IBACoS Lab Home

precast insulated concrete foundation panels. These early construction site studies were severely constrained by their high cost, limited sample size and questionable reliability of field observations.

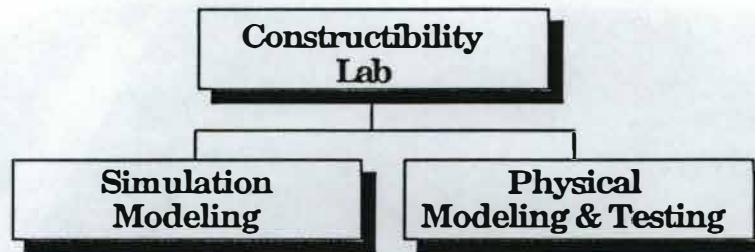

Figure 6-5, Homebuilding Constructibility Lab

As the cornerstone of our future strategy, we are developing a homebuilding constructibility lab (figure 6-5). The lab will allow the EEIH team to supplement expensive empirical field studies with both computer simulation and physical modeling and testing. Computer simulation will be used where it is best suited, in the factory, where operations are highly structured. Simulation capabilities will continue to be enhanced, for example, by the addition of embedded intelligence. Physical modeling and testing in a controlled laboratory environment should provide more objective, repeatable and cost-effective empirical results than field studies alone. Laboratory results should lead to enhanced component designs, improved manufacturing and construction processes, and a design for constructibility software tool which can be used to refine home designs, making them more constructible and maximizing value to the customer.

Concrete Homebuilding Components

The objective of this task is research current innovative concrete homebuilding technologies. Concrete technologies are of particular interest in Florida and other sunbelt states due to their inherent structural strength, thermal mass, and insect resistance. They have the added advantage of requiring no dimensional lumber or other forest products.

In FY94 we concentrated on identifying existing and emerging technologies. One such technology is the Superior Walls insulated concrete foundation panels bench marked in FY93 (figure 6-6). Data sources included research journals, trade

magazines, and the NAHB Research Center innovation database. As technologies were identified, vendors (or emerging product developers) were



Figure 6-6, Superior Wall Insulated Concrete Foundation

contacted for additional information, including marketing brochures and technical reports. We are currently preparing a report which summarizes our findings, including a classification of concrete systems and a description of typical technologies in each class.

7.0

FIELD TESTING OF WHOLE HOUSES AND COMPONENTS

Components Testing

The objective of this task is to test housing components for energy efficiency. Scale model testing and full-scale tests were performed using laboratory and field test facilities.

During FY94 the Flexible Roof Facility in Cocoa, FL was used to evaluate attic ventilation strategies and roofing materials. Side-by-side tests were conducted in this 24 ft. x 48 ft. facility (see figure 7-1), which has a large conditioned space under a 5 in 12 slope attic partitioned into six side-by-side test spaces.



Figure 7-1, The Flexible Roof Facility in Cocoa, Florida

Attic ventilation tests evaluated the effects of sealing an attic space or venting it with large soffitts and high-profile ridge vents compared to the traditional practice of venting with perforated soffitt and low-profile ridge vents.

Additional tests examined the beneficial effects of roofing tiles and white roofs. All test cells had a flat ceiling with R-19 ceiling insulation. The primary measurement was the temperature difference between the insulation top and the

ceiling bottom. This temperature difference is proportional to the ceiling heat flux, which directly impacts the air-conditioning energy use. Key results obtained during the summer of 1994 are summarized in figure 7-2.

Enhanced attic ventilation	25%
Sealed attic	-32%
S-shaped red concrete tiles installed traditionally	39%
S-shaped red concrete tiles on counter battens	48%
Seven-year-old radiant barrier	38%
Eleven-month-old white elastomeric paint	47%

Figure 7-2, Average Summertime Heat flux Reductions Compared to Roof with Black Shingles and Traditional Vents

Whole House Research

The main focus of this research area is on evaluating houses as systems made up of integrated and interacting components. The primary goal is to achieve a higher level of system integration and more coherent interaction between subsystems. This year we have made progress in whole house research through the avenues of building diagnostic testing, performance monitoring, computer simulation, and component development.

The Bonita Springs, FL project evaluated two side-by-side houses of the same design except that one had conventional wood frame walls while the other had walls of concrete/foam/concrete sandwich panels. Computer modeling of the two houses, using the DOE 2.1e building energy analysis program, was done to evaluate the potential to shift cooling load to off-peak hours due to the extra thermal mass of the concrete sandwich walls. Results showed only a small difference between the load shifting potential of the 7/8" thick concrete interior wall finish and conventional gypsum wallboard. Neither construction type would delay the need for cooling for more than 1.5 hours on peak days, after pre-cooling the house to 72°F and subsequently changing the setpoint to 79°F. Recommendations to reduce thermal shorting through the wire frame of the concrete sandwich panel were given to the investment firm interested in bringing the technology to Florida in the form of a production plant.

An incremental step was made toward realization of a short-term (one week) test

protocol. This would be conducted during the cooling season and aimed at predicting annual space conditioning energy use. A single-wide mobile home was used as the test subject on which the beta version of a cooling short-term energy monitoring protocol was executed. Results were encouraging because they showed excellent control of space temperature and accurate measurement of the cooling energy used. Future work will further refine the test protocol and explore the inclusion of modeling routines to separately account for latent loads and the effect of moisture absorption processes. In the process of investigating the best methodology to integrate ventilation and dehumidification into central cooling systems, a fan control device was developed, and the device is currently U. S. patent pending. This new device fills a void left by commercially available control products with regard to efficient, periodic air distribution in homes. Significant progress was also made in the early development of alternative construction framing members combining light gauge steel and engineered wood.

Two townhomes in Palmetto, FL, part of a block of ten townhomes called Parkwest, underwent building diagnostic testing and a one-month period of energy use and indoor air quality monitoring. These townhomes were constructed with the patented AMHOME technology. The unique feature is the walls, which are a concrete post-and-beam structures embedded in nine-inch-thick expanded polystyrene foam insulation. After a review of the construction details, recommendations were made to the developer to better seal a problematic area at the ceiling and wall interface, and to redesign the whole house fan ventilation system. These recommendations were not followed, and, as anticipated, the results were poor. The design and installation of the whole house fan system was so poor that it did little more than ventilate the attic over the garage. Building air tightness testing, by multi-point fan pressurization, showed large estimated natural air infiltration rates of .72 and .75 air changes per hour for the two townhomes. Measured air changes per hour at 50 Pascals pressure differential were high, at 9.6 and 10.9. To the credit of the AMHOME roof design, the central air distribution system is located entirely inside the conditioned space, and duct leakage was very low. Pressure differential diagnostics identified inadequate return air flow from closed rooms to the central return in the hall. Closed rooms were pressurized to as much as 22 Pa with

respect to the hall. Our original intent was to obtain one year of monitored energy use and indoor air quality data. However, one homeowner, whose monitoring system also included the weather station, became uncooperative due to issues unrelated to our work. Hence, useful data was obtained for only part of January and February. During this time period, space conditioning loads are typically quite low in south Florida. However, for the 27-day monitoring period, daily average outside temperature was always lower than inside, and a few days provided relatively significant heating loads. Figure 7-3 shows the average and peak daily electrical energy cost, at \$0.08/kW-h, for the whole house, heating and cooling, domestic hot water, and all other uses combined.

	Whole house		Heating and Cooling		Dom. Hot Water		Other (lights, refrig., stove, dryer, etc.)		Avg. In-Out Temperature Difference (F)	
	Unit 1	Unit 2	Unit 1	Unit 2	Unit 1	Unit 2	Unit 1	Unit 2	Unit 1	Unit 2
Avg. daily electrical energy cost (\$/day)	2.03	1.46	0.21	0.07	0.73	0.46	1.09	0.93	13.9	14.8
Max. daily electrical energy cost (\$/day)	5.73	2.35	1.18	0.54	1.26	0.7	3.59	1.44	22.7	19.3

Figure 7-3 Average and Peak Daily Electrical Energy Cost for 27-Day Period (@ \$0.08/kW-h)

Indoor air quality monitoring for this project consisted of simply measuring carbon dioxide concentration and relative humidity. Carbon dioxide concentration can be used to evaluate the adequacy of ventilation air relative to the number of occupants. Relative humidity can have a large effect on the presence of allergens such as dust mites and possibly mold and mildew spores. Unit 1 usually had three occupants with two in the master bedroom. Unit 2 usually had two occupants with one in the master bedroom. Master bedroom CO₂ concentration in Unit 1 was usually well above 1000 ppm during the night and early morning hours (often around 1800 and as high as 2400), while daytime levels were usually below 1000 ppm for both the master bedroom and living room. These data indicate that even in houses with relatively high air exchange rates, mechanical ventilation and good air distribution could provide more pleasing air quality in rooms occupied by two people during periods of lower nighttime infiltration and long periods of uninterrupted occupancy. Unit 2 CO₂

concentration was usually below 1000 ppm all of the time, and trends were not as evident as in Unit 1. Indoor relative humidity conditions could be considered ideal between 45 and 50%. At these conditions, dust mites and other biological allergens would be at low levels. For Unit 1, relative humidity was between 45 and 50% for 36% of the hours in the 27-day sample, while 100% of the hours fell below 70%. During the same monitoring period, hourly average relative humidity in Unit 2 was between 45 and 50% for 19% of the time, while 100% of the hours were below 75%. Figure 7-4 shows the frequency distribution for Unit 1.

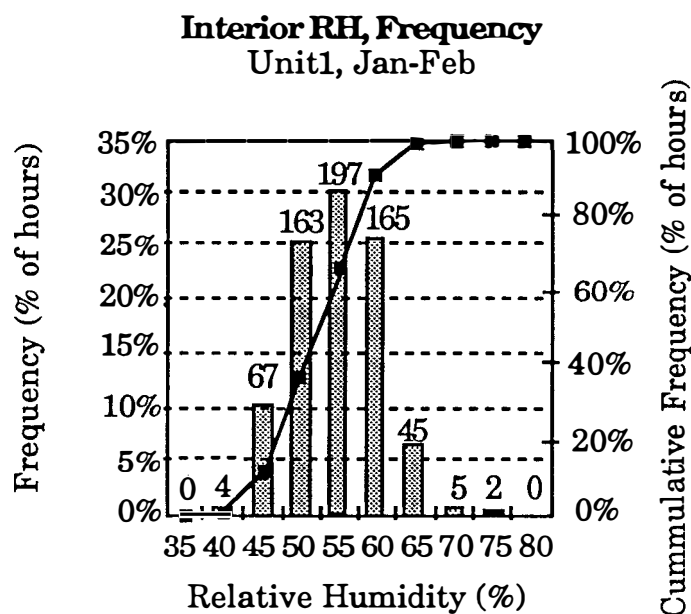

Figure 7-4, Indoor Relative Humidity Frequency for Unit 1 of the Parkwest Townhome Testing Project

University of Oregon Experimental Housing

The University of Oregon built six units of housing, designed by the Center for Housing Innovation, utilizing open, closed, and stressed skin insulating core wall panelization strategies. These houses were completed in the fall of 1993, and thermal diagnostic tests were conducted between November, 1993 and January, 1994. Energy monitoring of three units is ongoing.

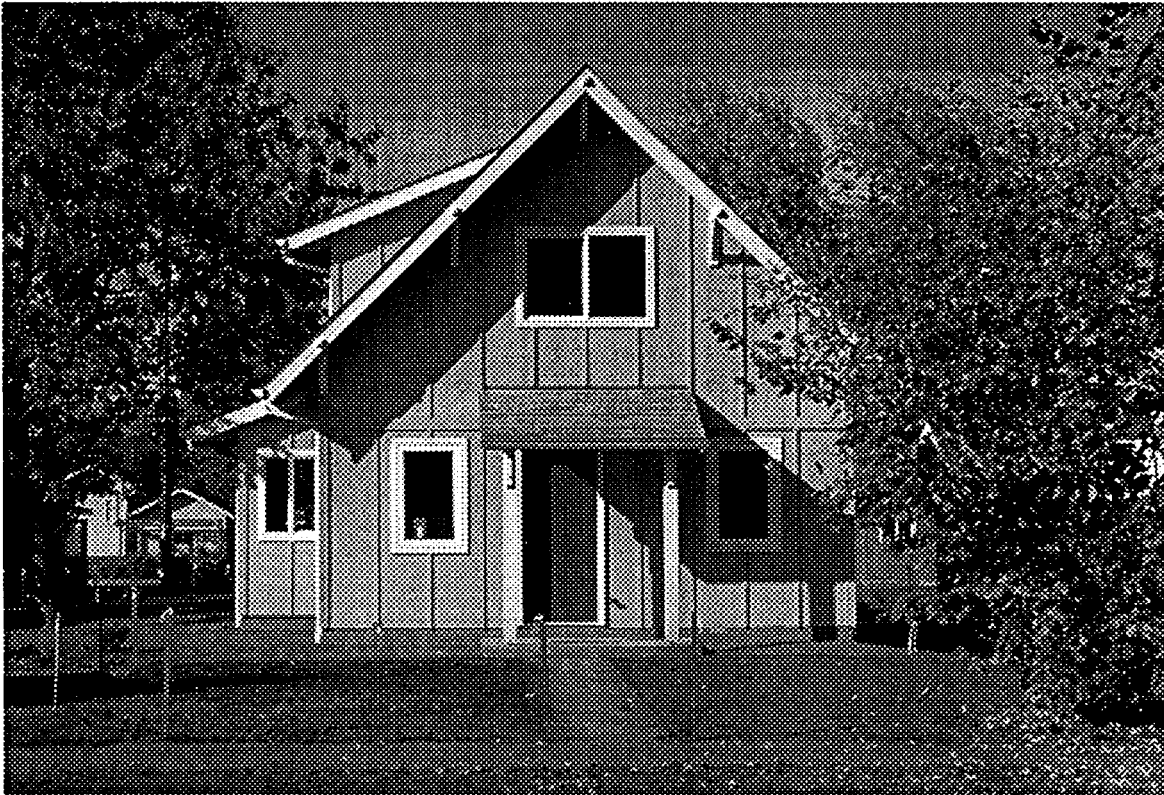

Figure 8-1, University of Oregon Experimental Housing

Open panels are shipped to the site sheathed on the exterior and with windows and siding installed. Insulation and the interior finish are installed on the site. Closed panels are shipped to the site with siding, sheathing, windows, insulation, vapor barriers, gypsum board, and electrical chases installed. Stressed skin insulating core, SSIC, panels are shipped to the site as a sandwich of oriented strand board, OSB, on the interior and exterior with an expanded polystyrene, EPS, core; interior and exterior finishes are applied in the field.

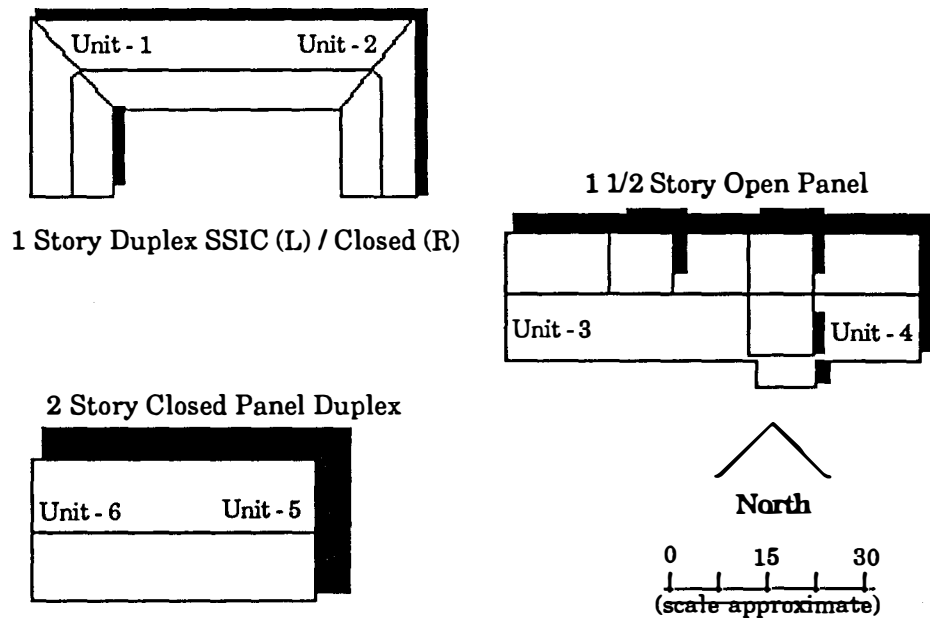
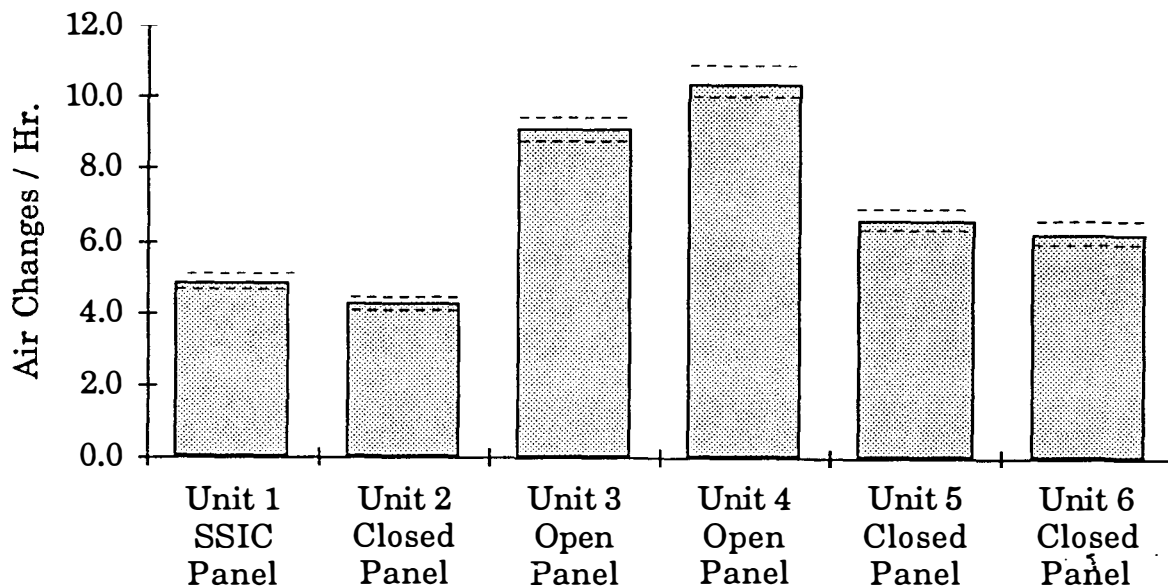

Figure 8-2.
Site Plan for University Housing Units

Results of the building diagnostic tests indicate clear differences in performance that appear to be linked to panelization strategy. The open panel units perform the worst in terms of airtightness whereas stressed skin insulating core panels and closed panels perform better. In addition, significant areas of conductive heat loss were detected with thermographic imaging in the walls and roof area of the Open panel units. The 1 story SSIC unit and the 1 story closed panel unit also had significant problems related to the installation of roof insulation (not panelized). Most problems related to missing insulation or poorly installed insulation occurred in areas where the insulation was installed on site.

Results of the infiltration tests indicate that the open panel units were the least airtight. Air changes per hour, ACH50, results indicate that the 1 1/2 story open panel units were the least airtight followed by the 2 story closed panel units, the 1 story SSIC panel unit, and the 1 story closed panel unit, respectively. The average air changes per hour at 50 pascals, ACH50, for the open panel units was 76% greater than the average ACH50 of the SSIC unit and the three closed panel units.



Note: dashes represent margin of error

Figure 8-3
Air Changes per Hour at a House Pressure of 50 Pascals

The results obtained by thermographic imaging showed that Units 3 and 4 had the most number of significant problems with insulation in the walls and ceiling. Unit 3 and 4 are both open panel construction, which means that all of the insulation was installed on site. Units 1 and 2 also had significant areas of missing or improperly installed insulation at the transition of vaulted insulation to flat roof insulation over the bathroom. This transition occurred within the overall roof envelope, so workers may have been more careless in installing this insulation. For the most part, the missing or improperly installed insulation corresponds to installation at the site whether in Units 1,2,3 or 4.

Coheating tests to establish an overall thermal transmittance value (UA) indicated that the 2 story closed panel units had the lowest overall conductance, followed by the 1 story SSIC unit, 1 story closed panel unit and 1 1/2 story open panel units respectively. When the coheating results were adjusted to account for heat loss due to infiltration and normalized by theoretical UA to account for differences in design, the 1 story SSIC unit, 1 story closed panel unit, and the 1 1/2 story open panel units did not perform as well as predicted by theoretical UA values. The significant problems associated with insulation detected by

thermographic imaging may be the cause of the poorer performance of units 1 through 4.

Stressed Skin Insulating Core Panel Demonstration House

The University of Oregon, Energy Studies in Buildings Laboratory (ESBL) constructed a stressed skin insulating core (SSIC) panel house in Springfield, Oregon in 1994 (see figure 4-1). A series of building diagnostic tests were performed by the ESBL between April and June of 1994. The objectives of the testing program were to assess the performance of the SSIC panel construction, confirm the design goal of energy performance of 40% better than the Oregon Energy Code, compare the performance of the SSIC Panel Demonstration House to a Reference House of similar design, and provide a baseline for long-term monitoring of the SSIC panel house.

Overall, results of the building diagnostic tests performed on the SSIC Panel Demonstration House indicate a high level of thermal performance and airtightness. Results of the fanned pressurization tests indicate that the SSIC Panel Demonstration House has an air change rate of approximately 0.086 air changes per hour. The estimates of natural infiltration rates compare well to infiltration rates determined through concentration decay tracer gas tests.

Effective leakage areas from the fan pressurization results were also compared to a theoretical effective leakage area for the Reference House. The Demonstration House was 43% more airtight in "open" conditions than the theoretical Reference House.

Overall, the Demonstration House was found to have an envelope that is much more airtight than the University Housing apartments described previously with panelized walls, manufactured truss roofs and slab-on-grade foundations. These results suggest that using SSIC panels for the entire building envelope results in a more airtight envelope than using only panelized wall systems.

Results of the coheating test indicate that the Demonstration House had a

measured UA value of 133 Btu/ h F. The measured UA value was 8% better than the theoretical UA value and 12% better than the theoretical UA value of the Reference House.

Overall, the coheating results indicate that the Demonstration House exceeds its goal of 40% better than the Oregon Energy Code. Again, the superior performance may be attributed to the utilization of SSIC panels for construction of the entire building envelope.

9.0 SPIRIT OF TODAY HOUSES

The objective of the spirit of today houses is to design and build a series of attractive energy-efficient homes that have additional features (eg. handicapped accessibility, excellent indoor air quality, strong wind resistant construction) to appeal to new home buyers.

In FY94, the first spirit of today house (see figures 9-1 and 9-2) was completed in January of 1995 in Orlando, FL. The house was sold before construction. As a result of favorable local press coverage, the open house drew 582 visitors in one Sunday afternoon. The indoor air quality system, the airtight wall insulation system and the handicapped accessible features (wide hallways, knee space under cooktop and sinks, roll in shower, barrier-free sloped front entry etc.) drew a lot of attention.



Figure 9-1, The Spirit of Today drew a crowd of 582 visitors during open house on January 8, 1995.

This house has been instrumented and is ready to collect data. Unfortunately, the house is for sale as the owners were transferred. We expect to begin

monitoring of the house when the house is sold and occupied again.

A smaller version (approx. 1800 sq. ft.) of this house was also designed and published. It appears that a variant of the smaller version will be built out of steel studs in a central Florida location in 1995.

Better Homes and Gardens magazine published a 12-page article on the houses in its October 1994 issue. As a result, millions of readers had the opportunity to learn about these innovative homes. The magazine also sells plans of the houses: a study set costs \$50, and a set of architectural drawings costs over \$200.

Over 220 persons have bought the study set plans, and about twenty architectural plans have been sold to date.



Figure 9-2, Spirit of Today kitchen / family room interior. Note the ceiling mounted instrumentation for monitoring temperature and humidity.

Future Partnership with the American Lung Associations of Central Florida and Hennepin County (ALACF and ALAHC)

In 1993 ALAHC developed the Health House™ concept. Health houses are resource-efficient houses that incorporate exemplary building techniques to

achieve outstanding indoor air quality. About one in four households have somebody (usually children) with a lung problem as a result of allergies or asthma. The rates of allergy and asthma incidence appear to be steadily increasing in the U.S. In 1993 one Health House was built in Minneapolis, MN. In 1994, four such homes were built in the cities of Detroit, MI; Rochester, NY; Raleigh, NC; and Minneapolis, MN.

The 1995 Orlando Health House™

Technical Highlights:

1. Energy-efficient central dehumidification / fresh air ventilation system with high-efficiency filters.
2. Airtight construction with non-CFC foam wall insulation = insulated slab perimeter.
3. Energy-efficient windows, solar water heater and roof tiles.
4. Low/no VOC cabinets, paints, glues, caulks and interior doors.
5. More than 40% of floor area with hardwood and tile floors.



Project Partners:

American Lung Association of Central Florida
Professional Builder Magazine



SCALE

Industry Partners to Date:

Hurd Millwork Co., Inc.
Whirlpool Corporation
S & S Mills Carpet
Eljer Industries
Kirby
Bruce Hardwood Floors
Therma Stor

THE ORLANDO HEALTH HOUSE™ 95
NORTH (FRONT) ELEVATION
Design: 3/8/95; Rev. 5/31/95
Designed by: Scott L. Philpott
Drawn by: Andrew M. Downing, FSEC

Figure 9-3, Orlando Health House™

In the summer of 1994 ALACF approached us regarding constructing a Health House in Orlando, FL. Realizing that the goals of Health Houses and Spirit of Today houses were nearly the same and recognizing the benefits of partnering with such a reputable organization, we decided to team with the American Lung Associations.

In 1995 two Health House projects are underway. A new house will be constructed in Orlando, FL. during the summer and fall of 1995. The proceeds from the sale of this house will benefit the ALACF who is spearheading the project. The house features and elevation are shown in figure 9-3. A key feature of this house will be central dehumidification. This is only possible because the house will be constructed to be airtight and then mechanically ventilated and dehumidified. Year-round dehumidification is expected to kill all the dust mites, a major indoor allergen. Slab perimeter edge insulation, large parts of the house covered with hardwood and tile floors, low-emission carpets, cabinets, interior doors, paints and glues will help occupants breathe easier. High efficiency air filters will minimize dust in the house and make house cleaning a breeze. This house will be featured in a 1996 issue of *Professional Builder* magazine, which is read by over 100,000 builders. The EEIH project secured the magazine sponsorship, developed the HVAC and insulation system design, and is helping with securing other product sponsors and coordinating with the builder (Mr. Scott Philpot) and his subcontractors. The EEIH project will financially assist ALACF in developing a project video, visitors guide and related publications. We also plan to conduct energy and indoor air quality monitoring of this and neighboring houses in 1996.

The second 1995 Health House project is a renovation project in Minneapolis which will be featured in a 1996 issue of the I magazine (read by over 20,000,000 people). This project is being conducted by ALAHC. The EEIH project introduced ALAHC to I and assisted in conducting building diagnostic tests which pinpointed certain problem areas to be remedied during the remodeling effort. The project will financially support ALAHC in developing Health House publications and media kits. We will also assist in conducting post-renovation building diagnostic tests.

The EEIH partnership with ALACF and ALAHC is truly a synergistic one where, with the help of DOE funding, we hope to foster the building or remodeling of many homes where people breathe easier literally and figuratively when they pay the lowered energy and medical bills.

10.0 PROCESS AND ENERGY EFFICIENCY REVIEWS (PEERs)-

The objective of this research is to offer recommendations that will enable specific industrialized housing manufacturers to increase both their productivity and the energy efficiency of their products. During FY94 the EEIH team prototyped a new approach to the PEER process. The new approach, termed a “focused” PEER, has two distinguishing features intended to enhance benefit to the manufacturer. First, it provides a smaller, focused consulting team for the plant visit. The team concentrates on a single area of improvement: design, energy efficiency, or manufacturing productivity. Second, more intensive follow-up is provided to insure that projected benefits are attained. The FY94 PEER effort with Glaize Components focused on improving manufacturing capacity and combined the PEER review with a field trial of the GIHMS simulator. The successful effort is described in section 5.0.

A Technology Characterization of the PEER process was also performed. Both the full-scope (design, energy efficiency, and manufacturing productivity) PEER and the focused PEER approaches were characterized. We found that the broad scope and limited depth of the full-scope PEER tends to generate poorly defined, loosely justified recommendations, instead of detailed, justifiable, implementable recommendations. The broad scope also serves to dilute the clients’ attention and resources and prevents them from focusing on key improvement opportunities. Finally, the broad scope greatly increases the cost of the visit. The focused PEER approach allows a prospective client to perform a self-assessment in order to identify areas of maximum opportunity and then to use EEIH team “experts” as needed. Based on results from the Glaize focused PEER prototype, the focused PEER was found to be more cost effective and marketable.

11.0 FY 94 PUBLICATIONS

- Aires, K., G.Z. Brown, J. Kline, R. Berg, & P. Kumar. "Cost Analysis: Stressed Skin Insulating Core Panel Demonstration House." Proceedings of *10,000 Solutions: Paths to a Renewable Future, Solar '95*, Minneapolis, MN, July, 1995 (*forthcoming*).
- Aires, K., G.Z. Brown, R. Berg, J. Kline, & P. Kumar. "Task 1.1 Baseline Cost Analysis and Task 1.2 Cost Analysis Springfield I Demonstration House." Report for the Center for Housing Innovation, University of Oregon, November 1994.
- Armacost, R., P. Componation, M. Mullens, & W. Swart. "An AHP Framework for Determining Customer Requirements in QFD: An Industrialized Housing Application." *IIE Transactions*, 26(4)72-79, July, 1994.
- Armacost, R., M. Mullens, & W. Swart. *A Cost Assessment of Innovative Homebuilding Technologies Used to Construct Exterior Structural Walls*. Report to U.S. DOE, Department of Industrial Engineering and Management Systems, University of Central Florida, Orlando, FL, Sept., 1994.
- Armacost, R., M. Mullens, & W. Swart. "Structuring a Simulation Modeling Environment Using a Commercial Manufacturing Simulator." *Proceedings of the 1994 Winter Simulation Conference*, Orlando, FL, December, 1994.
- Armacost, R., M. Mullens, & W. Swart. "Structuring a Simulation Modeling Environment Using a Commercial Manufacturing Simulator." *Proceedings of the Eleventh International Symposium on Automation and Robotics in Construction*, Brighton, England, May, 1994.
- Berg, R., G.Z. Brown, & J. Briscoe, M. Elliot, P. Gay, R. Kellett, B. Mitchell, S. Pierce, R. Rapp, R. Wilson. "SSIC Panel Demonstration House Phase I – First Design, Phase II – Second Design." Report for the Center for Housing Innovation, University of Oregon, December, 1994.
- Berg, R., G.Z. Brown, J. Briscoe, M. Elliot, P. Gay, G. Lei, B. Mitchell, R. Pearse, S. Pierce, D. Skilton, & R. Wilson. "SSIC Panel Demonstration House Phase III – Final Design and Construction." Report for the Center for Housing Innovation, University of Oregon, December 1994.
- Brown, G.Z., P. Kumar, & P. Larocque. "A Comparison of Energy Performance of Open and Closed Panel Construction." Proceedings of *10,000 Solutions: Paths to a Renewable Future, Solar '95*, Minneapolis, MN, July, 1995.
- Brown, G.Z., J. Kline, M. Meacham, R. Sanders, D. Oshatz, E. Hendrickson, P.

- Kumar, & R. Pearse. "Prototype Sales to Manufacturing Design Tool." Report for the Center for Housing Innovation, University of Oregon, August 1994.
- Chandra, S. "Spirit of Today: A Resource-Efficient Housing Demonstration Program, *International Journal of Housing Science and its Applications*, Vol. 18 No. 4, pp. 231-238, 1994.
- Mullens, M., R. Armacost, W. Swart, & J. Crowley. "Benchmarking the Constructability of Innovative Net Shape Homebuilding Technologies." *International Journal for Housing Science and Its Applications*. (forthcoming)
- Mullens, M., T. Gawlik & M. Malek. *Benchmarking the Constructability of the MIT Roof System on IBACoS Lab Home B*, Report to U.S. DOE, Department of Industrial Engineering and Management Systems, University of Central Florida, Orlando, FL, June, 1995.
- Mullens, M., R. Armacost, & W. Swart. "Benchmarking Construction Costs for Innovative Homebuilding Technologies." *Building Research Journal*, 3(2)81-102, Fall 1994.
- Mullens, M., R. Armacost, & W. Swart. "The Role of Object Oriented CAD in a Generic Simulator for the Industrialized Housing Industry." *Automation in Construction*, 4(1)29-43, March, 1995.
- Mullens, M. & R. Toleti. *Simulating the Makron Wall Panel Line at Glaize Components*. Report to U.S. DOE, Department of Industrialized Engineering and Management Systems, University of Central Florida, Orlando, FL, June, 1995.
- Mullens, M. & R. Toleti. "Simulation Helps Homebuilding Move Indoors." *Interfaces*. (under review)
- Rudd, A. "Development of Moisture Storage Coatings for Enthalpy Storage Wallboard." ASHRAE Transactions: Research V. 100, Pt. 1.a. ASHRAE, Atlanta, GA, 1994.
- Rudd, A, S. Katakam, & S. Chandra. "Measured and Predicted Energy Savings from an Industrialized House." Proceedings of the ACEEE 94 Summer Study on Energy Efficiency in Buildings, American Council for an Energy Efficient Economy, Pacific Grove, CA, Aug. 28-Sep. 3, 1994.
- Rudd, A., & S. Chandra. "Side-by-Side Evaluation of a Stressed-Skin Insulated-Core Panel House and a Conventional Stud-Frame House." Proceedings of the EEBA 1994 Conference on Excellence In Housing, Energy Efficient Building Association, Dallas, TX, Feb. 23-26, 1994.

12.0 ACKNOWLEDGEMENTS

This research is funded by the Office of Building Technology, Energy Efficiency and Renewable Energy Division of the U.S. Department of Energy, Mr. George James, Program Manager.

