



THE UNIVERSITY *of* EDINBURGH

Edinburgh Research Explorer

Life cycle assessment of the Seagen marine current turbine

Citation for published version:

Douglas, CA, Harrison, G & Chick, J 2008, 'Life cycle assessment of the Seagen marine current turbine' Proceedings of the Institution of Mechanical Engineers, Part M: Journal of Engineering for the Maritime Environment, vol. 222, no. 1, pp. 1-12. DOI: 10.1243/14750902JEME94, 10.1243/14750902JEME94

Digital Object Identifier (DOI):

[10.1243/14750902JEME94](https://doi.org/10.1243/14750902JEME94)

[10.1243/14750902JEME94](https://doi.org/10.1243/14750902JEME94)

Link:

[Link to publication record in Edinburgh Research Explorer](#)

Document Version:

Peer reviewed version

Published In:

Proceedings of the Institution of Mechanical Engineers, Part M: Journal of Engineering for the Maritime Environment

Publisher Rights Statement:

The final, definitive version of this paper has been published in Proceedings of the Institution of Mechanical Engineers, Part M: Journal of Engineering for Maritime Environment, 222, 2008 by SAGE Publications Ltd, All rights reserved. © [IMechE]

General rights

Copyright for the publications made accessible via the Edinburgh Research Explorer is retained by the author(s) and / or other copyright owners and it is a condition of accessing these publications that users recognise and abide by the legal requirements associated with these rights.

Take down policy

The University of Edinburgh has made every reasonable effort to ensure that Edinburgh Research Explorer content complies with UK legislation. If you believe that the public display of this file breaches copyright please contact openaccess@ed.ac.uk providing details, and we will remove access to the work immediately and investigate your claim.



Life Cycle Assessment of the Seagen Marine Current Turbine

C. L. Douglas, G. P. Harrison* and J. P. Chick

School of Engineering & Electronics
University of Edinburgh
Mayfield Road
Edinburgh EH9 3JL

*Corresponding author: Gareth.Harrison@ed.ac.uk ; Tel +44 131 650 5583

ABSTRACT

The world's first commercial-scale grid-connected tidal current energy installation will feature the Seagen marine current turbine developed by Marine Current Turbines Ltd. With potential for the manufacture of significant numbers of such devices there is a need to assess their environmental impact and, in particular, their life cycle energy and carbon dioxide (CO₂) performance.

This paper presents an analysis of the life cycle energy use and CO₂ emissions associated with the first generation of Seagen turbines. With relatively conservative assumptions, the study shows that at 214kJ/kWh and 15gCO₂/kWh, the respective energy and carbon intensities are comparable with large wind turbines and very low relative to fossil-fuelled generation. The energy payback period is approximately 14 months and the CO₂ payback is around 8 months.

Materials use is identified as the primary contributors to embodied energy and carbon with shipping also significant. Improvements in the environmental impact of the Seagen can be achieved primarily by increased structural efficiency and the use of alternative installation methods to increase recovery of steel at decommissioning.

Keywords: Life cycle analysis, marine currents, tidal energy, tidal stream.

1 INTRODUCTION

Concerns over climate change are driving attempts to create a low carbon economy. Renewable energy is expected to play a key role in this, and the Government of the United Kingdom (UK) have implemented the Renewables Obligation (RO) which requires electricity generators to supply 10% of electricity from renewable sources by 2010, with an aspiration of 20% by 2020 (targets in Scotland are more significant). The UK's marine energy resources are believed to have the potential to supply 15-20% of electricity demand [1]. A key component of the marine resource is tidal energy and, while there has been much discussion of barrages in the Severn and Mersey, it has not been commercially exploited. However, an alternative method for extracting energy from tidal currents is approaching commercial reality.

Tidal stream technology is one of the most recent forms of renewable energy to be developed. The advantages offered by tidal stream technology include [2]-[3]: no pollution and negligible environmental impact, entirely predictable energy delivery as currents are driven by gravity rather than weather, areas of potential development are generally under-utilised and the energy intensity is higher than other renewables. The power that can be drawn from tidal currents is highly sensitive to the velocity of currents and output will vary depending on the location of the turbine. The basic requirements for cost-effective tidal stream power generation are typically a mean spring peak velocity exceeding 2.25–2.5m/s in a 30–40m depth of water. Various sites around the UK such as the Pentland Firth (northern Scotland) and Alderney Race (Channel Islands) have been identified with the potential to supply energy on the multi-gigawatt scale [4].

One of the devices designed to harness this resource has been developed by Bristol-based Marine Current Turbines Ltd (MCT). Their Seagen turbine has twin underwater rotors deployed on a steel monopile. It will shortly be deployed at Strangford Narrows at the entrance to Strangford Lough in Northern Ireland and will be the first full-scale commercial prototype tidal turbine. Success for the project could lead to development of a programme of tidal current farms involving manufacture of a large number of Seagen devices. As such, it is important that the environmental impact of the Seagen is evaluated and one of the key aspects is its life cycle energy and carbon dioxide (CO₂) performance.

The only existing life cycle studies of marine energy converters have been first-order estimates of wave energy device carbon and energy intensity based on the mass of structural steel. Banerjee *et al.* [5] estimate the carbon intensity of the Pelamis device to be just under

40gCO₂/kWh while the Carbon Trust [1] suggest that an unnamed wave device has a carbon intensity of 25–50gCO₂/kWh and carbon payback in the region of 14 to 21 months.

This paper sets out a detailed life cycle analysis of the Seagen tidal current turbine which is believed to be the first analysis published for this technology. It evaluates the energy consumption and CO₂ production involved in each stage of its life cycle from ‘cradle to grave’ and compares these with other electricity generating sources. These figures allow derivation of the energy and the CO₂ payback times.

The paper is set out as follows: Section 2 briefly introduces the concept of life cycle analysis, outlines the features of the Seagen turbine and sets out the scope of the study. Section 3 provides a detailed breakdown of the assessment while Sections 4 presents the embodied energy and CO₂ for the device and sets the findings in context.

2 LIFE CYCLE ASSESSMENT OF A TIDAL STREAM TURBINE

2.1 Life cycle assessment

Life cycle assessment (LCA), also known as a cradle to grave analysis, is an assessment of all the environmental impacts of a product, process or service within its complete life cycle. LCA has its roots in the 1960s when concern over rapid depletion of fossil fuels led to an approach that allowed understanding of the impacts of energy consumption [6]. LCA can identify energy and materials use and waste released to the environment, as well as evaluation and implementation of opportunities for improvements. LCA studies should comply with the international standard ISO 14040, which specifies the general framework, principles and requirements for conducting and reporting such assessments [7]. LCAs have been applied to a range of electricity generating technologies including nuclear [8], fossil-fuelled plant [9] and renewables like wind [10]-[14].

Life cycle assessments can be used as a product or process design improvement tool helping designers and engineers to identify the environmental factors attributed to specific materials or life cycle stages, ultimately allowing sound and informed decisions and improvements to be made. The LCA will also be of interest to potential investors, energy and government authorities who may consider the environmental implications of the product before investing or commissioning such a project.

LCA addresses only the environmental issues that are specified in the goal and scope and is therefore not a complete assessment of all environmental issues of the system under study. Limitations include the system boundary not encompassing all possible processes, inputs or

outputs; the non-availability of inventory data leading to assumptions and/or omissions; and inadequate quality of inventory data leading to error [7].

The life cycle of the Seagen marine current turbine consists of a series of stages, as illustrated in Figure 1. Materials and manufacturing includes the entire method of manufacturing the turbines components, from raw material extraction and processing through to further component treatment. Transportation and installation includes energy consumption and emissions from the transportation of components to the assembly site and then on to the installation site. It also includes all materials and processes used during the installation procedure. Operations and maintenance (O&M) includes energy and emissions related to any process or materials used during operation and maintenance throughout the turbines lifetime. Transportation to the installation site, repairs and replacement materials are included. Decommissioning and disposal includes transportation to and from the site at the end of the life cycle, energy and emissions related to the dismantling process as well as the effect of recycling or disposal of materials.

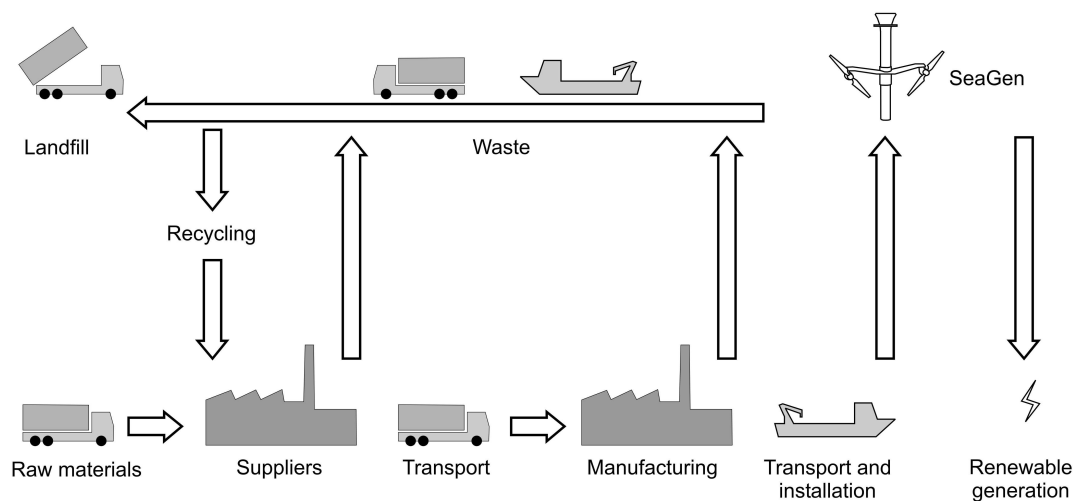

Figure 1. Seagen life cycle stages, after [10]-[11].

2.2 The Seagen Marine Current Turbine

Marine Current Turbines Ltd was set up to pioneer the technical and commercial development of tidal stream turbines and has developed a novel method of extracting power from marine currents [15]. The 300kW prototype, SeaFlow, installed in the Bristol Channel in May 2003, resembles a wind turbine as it has an axial flow turbine mounted on a tubular steel tower. The 1.2MW production version, Seagen, extends the concept with twin 16m diameter axial flow rotors mounted on a crossbeam either side of the steel tower. Lift legs run either side of

the tower providing the capability of lifting the crossbeam and rotors above the surface for maintenance. The platform and pod sit on top of the tower. An illustration of the Seagen turbine is shown in Figure 2.



Figure 2. Artists impression of the Seagen Marine Current Turbine.

The Seagen is in the process of being installed at Strangford Narrows at the entrance to Strangford Lough in Northern Ireland and extensive environmental assessments and monitoring have been carried out [16]. The characteristics and features of this development are assumed in this assessment. Harmonic analysis has been carried out at the site providing tidal current distribution information and flow velocities (Figure 3). Combining current data with the power curve data for each of the Seagen twin turbines (also Figure 3) allows prediction of the annual power output. The estimated maximum power output for the turbine is 5,038MWh although adjusting this for predicted periods of downtime reduces the output to 4,736MWh/year (assuming 94% availability); this assessment assumes the lower production level. A summary of the technical specifications are given in Table 1.

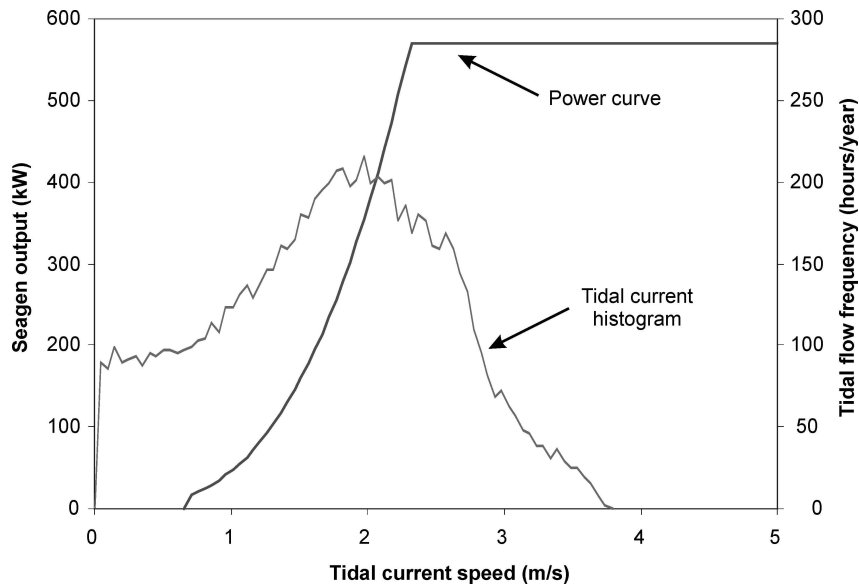

Figure 3. Tidal current histogram for Strangford Narrows and Seagen power curve.

Parameter	Value
Rated power	1.2MW
Capacity factor	40%
Rotor diameter	16m
Design life	20 years
Reliability	>90%
Overall efficiency	89%
Design rotor power coefficient	0.45
Cut-in speed	0.7m/s
Rated speed	2.25m/s

Table 1. Technical specifications of Seagen Marine Current Turbine.

2.3 Scope of Assessment

The assessment analyses all incoming and outgoing materials and required processes throughout the 20 year life cycle of the Seagen marine current turbine, including foundations and grid connection. The system boundary indicates what is, and what is not, included in the analysis. This study achieves a ‘cradle to grave’ boundary by considering all energy input and carbon emissions from the extraction of the raw materials used in manufacture from their natural state to the complete disposal of the machine at its end-of-life (Figure 1). Physically, the system boundary ends at the end of the sub-sea cable with all downstream elements of the electricity transmission system outside the scope of this study.

Energy and emissions associated with capital plant (e.g., machinery) has been restricted to operation (e.g., fuel/electricity consumption) and excludes any emissions due to their manufacture. In line with Department for Environment and Rural Affairs (DEFRA) guidelines [17], it is assumed that electricity consumed throughout the life cycle comes from the UK grid and has a CO₂ intensity of 0.43kgCO₂/kWh.

3 LIFE CYCLE INVENTORY ANALYSIS

3.1 Procedure

The collection of inventory data relating to the components and life cycle stages of the Seagen turbine was based on many sources of information supplied by MCT including a bill of materials, mass breakdown of main components, component drawings, the Seagen Environmental Statement [16] and data gathered from meetings with MCT staff.

The bill of materials listed over 600 components used in the turbine, the supplier and cost. Assessing every component was infeasible within the available timescale so the priority was to establish the components with significant embodied energy and CO₂. Information gathered from meetings with MCT staff, component drawings and the bill of materials was analysed and a database of all significant components was produced. The mass of each was established along with the material breakdown and manufacturing processes for the component.

Information on the embodied energy and carbon content of materials and manufacturing processes was obtained from many sources including existing LCAs, journals and textbooks published by recognised bodies. Where information on material breakdown and manufacturing process was not available, it was first assessed if this information would likely be significant. If so further research was conducted and, when necessary, assumptions were made based on similar materials or components.

3.2 Raw materials

Figure 4 shows the most significant materials used in the manufacture of the Seagen turbine. Steel is used for most of the major components like the 242t tower, the topside platform and the crossbeam which explains why it represents nearly 89% of the 465t total mass.

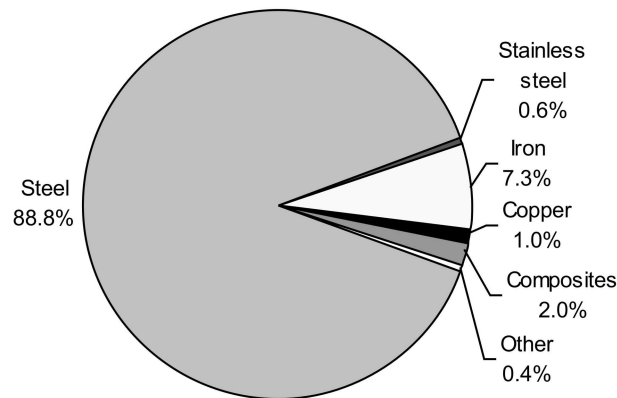

Figure 4. Mass breakdown of Seagen turbine.

Data for material embodied energy and carbon is given in Table 2. It is primarily based on the Inventory of Carbon and Energy (ICE) [18], a database compiled by the University of Bath. The dataset offers a ‘cradle-to-gate’ assessment covering exploration and extraction of the raw and feedstock materials to the production of the processed material ready for collection at the factory gate. Its well-documented methodology is designed to ensure consistency and remove ambiguity through rigorous survey of secondary sources, and is derived, where possible, from UK sources. For this preliminary assessment it has been assumed that components possess embodied energy and CO₂ as though they were produced in the UK. Although many of the most significant components are produced outside of the UK, this is believed to be a reasonable approach. Cross-referencing of ICE data for steel products with European average data from the International Iron and Steel Institute [19] suggests that, if anything, the ICE data is more conservative (i.e., higher embodied values).

Data for materials not covered by the ICE have been sourced from elsewhere in the literature: technical journals, conference papers and previous LCA studies, preferably accredited to ISO 14040. Embodied energy values for cast iron (used primarily in the gearboxes, hubs and electrical components) was sourced from [20] and the embodied CO₂ was estimated based on the assumption that CO₂ emissions reflect the relative energy use between iron and steel. Around 9t of composite material is used for the turbine rotor blades, crossbeam fairings (housing) and pod. The composites are manufactured from glass fibre, foam and epoxy resin with a small amount of carbon fibre used in the rotor blades. [21] states embodied energy values for the composite material and provides an energy-CO₂ relationship to allow calculation of CO₂ emissions. Other data was sourced for epoxy resin and polyurethane foam filler [22].

Material	Embodied Energy (MJ/kg)	Embodied CO ₂ (kgCO ₂ /kg)
Aluminium (range: rolled – cast)	150.2–167.5	8.35–9.21
Carbon/glass fibre [21]	200.0	11.2
Cast iron [20]	37.0	3.3
Cement	2.35	0.28
Copper	55.0	4.38
Epoxy resin [22]	137.1	13.8
Nylon 6	120.5	5.5
Paint	80	6.1
Polyethylene/polypropylene	73.7	1.7
Polyurethane foam [22]	102.9	3.9
PVC Pipe	67.5	2.5
Stainless Steel	51.5	6.15
Steel (range: engineering – plate)	11.7–45.4	0.68–3.19

Table 2. Summary of energy and CO₂ intensity of key materials, [18] unless specified

3.3 Manufacturing

3.3.1 Manufacturing processes

The material life cycle inventory data specifies ‘cradle-to-gate’ values which exclude downstream manufacturing processes. Where information on the downstream manufacturing processes was available it has been included in the assessment but data on some processes (e.g., forging) is not extensively documented and assumptions have been made. Table 3 summarises the energy requirement for selected manufacturing processes.

Process	Energy Input	CO ₂ Emissions
Composite Pre-Preg [23]	40 MJ/kg	4.78 kgCO ₂ /kg
Flame Cutting [24]	8.5 MJ/m ²	1.015 kgCO ₂ /kg
Machining [25]	60 kJ/cm ³	0.15 gCO ₂ /cm ³
Sandblasting [26]	12.0 MJ/m ²	1.44 kgCO ₂ /m ²
Sand Casting [27]	9.8 MJ/kg	1.172 kgCO ₂ /kg
Welding [24]	15.1 MJ/m	1.804 kgCO ₂ /m

Table 3 Embodied energy and CO₂ for selected manufacturing processes

3.3.2 Tower

The tower for the Seagen is manufactured in Denmark and shipped complete to the assembly site ready to be installed. The 54.6m tall structure is fabricated from steel plates rolled and welded into circular sections. Stainless steel, cast iron and galvanised steel sections complete the tower. The external surface above the sea bed and the entire internal surface is sand blasted, painted and partially aluminium cathode protected.

3.3.3 Crossbeam

The crossbeam supports the rotors and consists of a 92t fabricated steel structure, moulded composite fairings and iron castings. The steel and iron components are corrosion protected. The composite crossbeam fairings which cover the structure are assumed to be made using the pre-preg [23] process consisting of 70% glass fibre, 5% foam and 25% epoxy resin; the external surface is painted. It was assumed that 10% of the composite material was wasted and disposed of in landfill; this is in line with LCA data for wind turbines [10].

3.3.4 Rotor Blades and Power Train

The turbine has two power trains, each consisting of two rotor blades, hub, gearbox, generator and frequency converter (Fig 5). A single transformer (housed in the topside) connects them to the sub-sea cable. MCT supplied component masses and some manufacturing information but the remaining components were assessed based on LCAs of similar devices. Each rotor blade is made up of 800kg of composite material for the blade spar and skin together with a cast iron hub-connector. The blade composites had a similar composition and wastage to the crossbeam fairings. The hub assembly is mostly cast iron (machined and protected) along with two forged steel bearings. Each gearbox is made from a cast iron casing, forged steel gears and shaft, structural steel and oil; an estimate of the breakdown was provided by MCT. Allowance was made for high accuracy machining of the shaft and gears but the minor contribution from heat treatment was omitted. LCAs for similar electrical components facilitated estimates for the 660kW induction generators [28], frequency converters [29], distribution transformer [30] and the 22kW induction motors controlling the blade pitch [31]. These components comprise mostly steel elements along with iron, copper and aluminium.

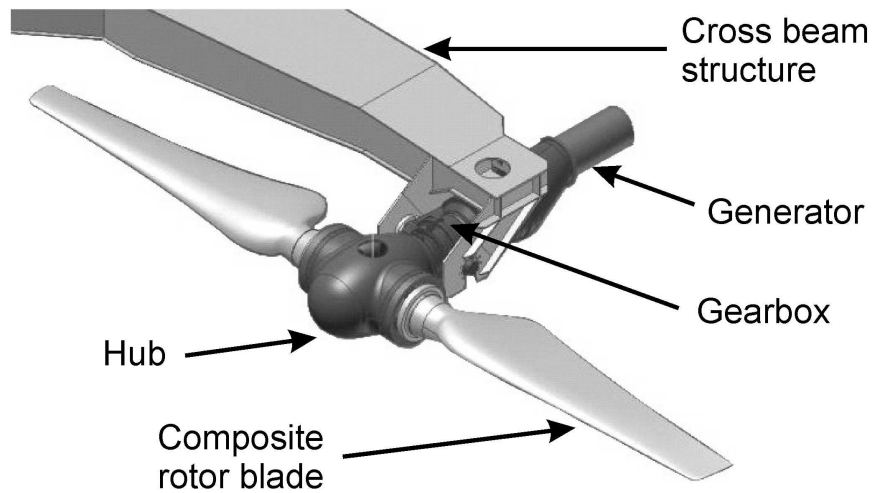

Figure 5. Seagen power train.

3.3.5 Manufacturing of the topside

The topside is the assembly that sits on top of the tower clear of the water. The 56t assembly is mostly steel, housing the controls, electronics and hydraulic systems and a crane. A 1t glass fibre pod curves round the topside steel fabrication and is manufactured in a similar manner to the crossbeam fairings. Three steel ‘tea strainers’ act as the tower’s floors and house the steel control and electronics cabinets. LCA data for an industrial controller [32] was used to estimate the control and electronics footprint; this assumption will have negligible impact given the low mass of the control units. The hydraulic system allows the rotors and crossbeam to be raised for maintenance. MCT provided a component and weight breakdown and the twin 22kW motors were modelled as per the blade pitch motors [31]. The omission of hydraulic pumps, bore valves and filters from the analysis does not significantly understate the energy and CO₂ burden.

3.3.6 Cabling

A 500m armoured multi-core cable connects the turbine to the distribution network. Each 107mm² copper core is surrounded by 4.5mm of XLPE insulation with the whole cable protected by 5mm of steel armour wire and a 3.5mm polypropylene sleeve. This material, along with 222m of 394mm² copper cable is included in the assessment but low voltage cabling has been omitted as the total mass was not significant.

3.4 Transportation and Installation

The transportation stage of the life cycle required assessment of the fuel use and CO₂ emitted by vehicles transporting turbine components to the assembly and installation sites. The DEFRA guidelines for emissions reporting provide fuel consumption and emissions for most transport modes [17]. Emissions for other, more specialist shipping and vehicles were

derived, where necessary, from product specifications. They assumed the use of diesel with embodied CO₂ of 2.63 kgCO₂/l [17] and are presented in Table 4.

The turbine is preassembled prior to installation at the assembly site in Belfast, N. Ireland. For the 21 most significant components (~96% of the total weight) the distance from the supplier to the assembly site was calculated. Most are transported by road but the tower, crossbeam and another minor fabrication are transported 1520km by cargo ship from Denmark. Some assemblies, e.g., the power train, are pre-tested elsewhere before delivery to Belfast; however, the assumption that each component is delivered direct to the assembly site is reasonable given the relatively small distances involved. On the basis of their size and weight, the other 18 most significant components were assumed to be transported by either a 28t articulated lorry or a 10t rigid lorry. The remaining 22t of components were estimated to require the use of five rigid lorry loads (at 50% loading) for the weighted average travel distance (811km) of the 21 main components.

	Fuel consumption l/km	CO ₂ emissions kgCO ₂ /km
Cargo ship (1000t load)	14	36.82
Tug boat (40t pull) [33]	16	42.08
Multicat (2000 bhp) [34]	8.5	22.35
Inspection vessel [34]	3.3	8.76
100t mobile crane [35]	0.94	2.47

Table 4 Fuel consumption and CO₂ emissions associated with various transport modes

The installation procedure for the Seagen turbine is outlined in the company's Environmental Statement [16]. Components are assembled then transported as a number of main assemblies to the installation site at Strangford Lough Narrows, approximately 100km from Belfast. The bulk of the components are transported to the installation site on a marine jack up platform, towed and positioned by two tugboats [16]. The remainder of the installation-related transport emissions come from a Multicat workboat (which carries the remaining components) and the use of a mobile crane and van (Table 4). The installation involves a 4m diameter, 23m deep hole being drilled into the sea bed along with a 500m-long directionally-drilled tube for the sub-sea cable. The energy and CO₂ emissions from the drilling operations were estimated from the duration of the processes and relevant technical data sheets. The mobile crane was assumed to operate for around half of the working time at the site consuming fuel at around 9l/h [35]. In addition to the use of fuel, the installation also requires the use of a 26t sacrificial

steel shoe (drill bit left in the sea bed) and 75t high strength polymeric grout. The tugboats make a second return journey to collect the barge.

3.5 Operations and Maintenance

The operations and maintenance schedule for the Seagen turbine, outlined by MCT, involves a six-monthly inspection cycle and the removal, inspection and refurbishment of the power train on a five-yearly cycle. The six-monthly inspection will require the use of a boat to transport the inspection team and the hydraulic system provides the energy required to lift the cross beam above the water surface. The five-yearly power train refurbishment requires a Multicat vessel and crane to swap the complete system for another. The embodied energy and CO₂ of replacement components such as bearings, gearbox oil and paint are included in the analysis but that of the entire replacement power train is not included as a spare power train can service an entire farm of Seagen turbines.

3.6 Decommissioning and Disposal

While the decommissioning process for the Seagen turbine has not been considered in detail at present, it is expected to be largely a reversal of the installation procedure. The tower would be removed by cutting its circumference around 0.5m below the seabed. The top section of the tower will be returned to land with the remaining 22.6m left below the seabed. As the tower wall is thicker at the base the foundation represents 51% of the tower mass which could otherwise be recycled. The sub-sea cable can be left in situ or recovered for disposal or recycling; the latter is assumed here.

LCA studies for other renewable technologies demonstrate that the recycling stage of the life cycle have a significant impact on embodied energy and CO₂ [10], [11], [13]. By recycling material, the energy consumed and CO₂ produced through raw material extraction and primary processing can be avoided. The savings, which typically range from 60% for steel up to 95% for aluminium, can be credited to the life cycle and reduce overall energy and CO₂ intensities and paybacks. Allowable under ISO 14040 [7], a series of methodologies have been developed for the recycling of metals [36]-[37]. The key factor in determining the level of credit is the rate of recycling [36].

As Seagen has not yet been installed, scenarios for recycling and disposal were based on two assessments of large wind turbines produced by Vestas. The first [10] applied a conservative 90% recycling scenario for steel to account for uncertainty while the later study [11] assumed 100% recycling. Given the level of uncertainty here, it has been assumed that 90% of all steel components other than the tower are recycled with the data based on the same materials values from the ICE database [18]. With half of the tower remaining in the seabed following

decommissioning, only 49% of the steel tower mass is assumed to be recovered. All other recycling rates materials are based on [10] with rates of 90% for iron, 95% for copper with plastics and composites to going to landfill.

4 RESULTS AND DISCUSSION

4.1 Energy consumption and CO₂ emissions

Figure 6 shows the respective embodied energy and CO₂ emissions for each of the life cycle stages for the Seagen turbine. The gross embodied energy (i.e., excluding the recycling credit) is 25884GJ with the most significant stage being the materials and manufacturing stage, accounting for 86% of gross energy consumption. The gross life cycle production of CO₂ is 1921t with a similar proportion represented by materials and manufacturing.

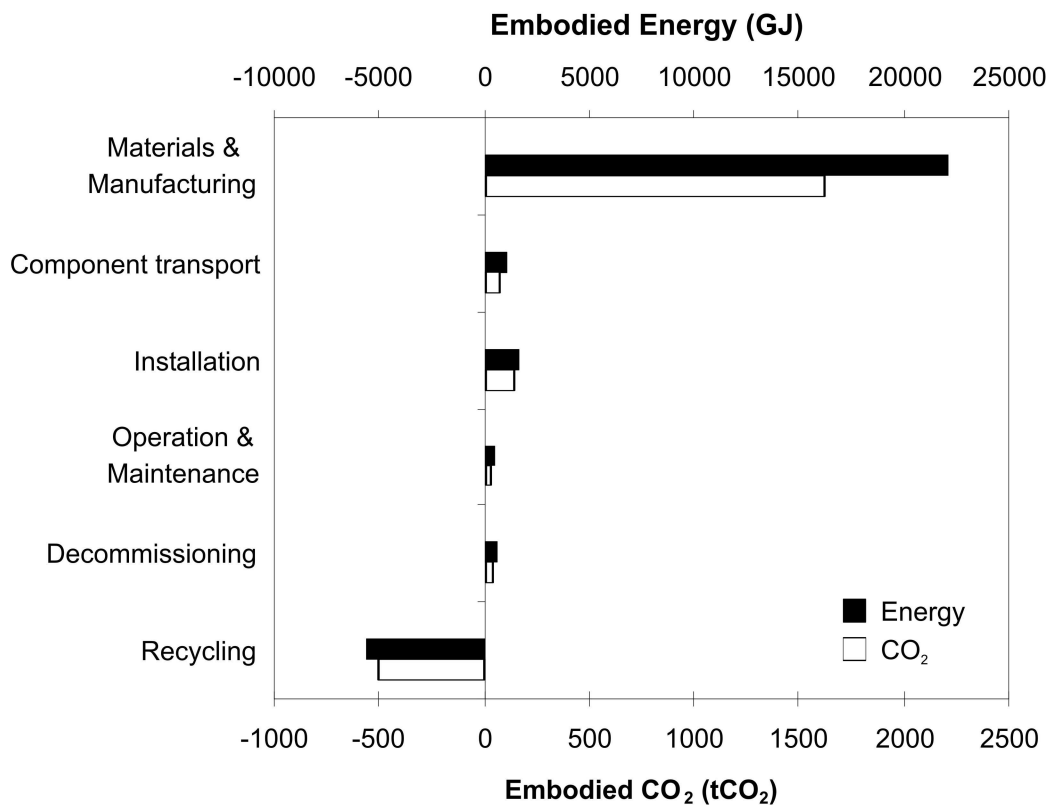

Figure 6. Energy consumption and CO₂ emissions per life cycle stage.

The credit offered by recycling is significant with the 22% credit lowering the net embodied energy by 5579GJ to 20305GJ and the 26% carbon credit lowering embodied CO₂ to 1417tCO₂. The recycling credits are lower than the 30% values for wind turbines [11] which is partly due to the conservative recycling rates assumed (typically 90%) but primarily as a result of less than half of the tower being recovered and recycled. Should it be feasible to retrieve the entire tower and recycle 90% of it then the recycling credits would be raised to

35% for energy and 42% for CO₂. The impact of the recycling credit is explored further in the sensitivity analysis in Section 5.2.

Steel use is by far the main contributor to the overall embodied energy and CO₂ emissions, responsible for 68% of the total gross energy consumption. It should be noted, however, that over 85% of the total recycling credit comes from steel. Composite materials contribute disproportionately as although representing only 2% of the turbine mass they are responsible for 9.4% of embodied energy and 7.9% of embodied CO₂. The use of diesel fuel, mainly for shipping, is also significant and represents around 15% of net life cycle energy and CO₂.

4.2 Energy and carbon intensity

To allow comparisons to be made between Seagen and other electricity generating technologies, the energy and CO₂ intensities, i.e., per unit of production, were calculated. This was done by dividing the overall embodied energy and CO₂ emissions by the total production of the turbine over its lifetime.

At the Strangford site, annual production of 4,736MWh equates to 94.7GWh over the 20-year lifetime. Dividing the net life cycle energy consumption by the lifetime production indicates an energy intensity of 214kJ/kWh. Similarly, the life cycle CO₂ emissions result in a carbon intensity of 15.0gCO₂/kWh. Omission of the recycling credits raises the respective intensities to 273kJ/kWh and 20.3gCO₂/kWh. A discussion on how these values relate to other electrical generation technologies follows in Section 4.3.

The performance of the device can also be measured by payback periods which indicate how quickly embodied energy and CO₂ are 'recovered' by the carbon-free energy produced by Seagen. The energy payback period is ascertained by dividing the lifetime energy input by the annual energy production:

$$\text{Energy Payback} = \frac{\text{Life cycle embodied energy}}{\text{Annual energy production}} \quad (1)$$

The energy payback is therefore 14.3 months. Omission of the recycling credit from the calculation increases the payback period to 18.2 months. Similarly, the carbon payback can be ascertained by dividing the total embodied carbon by the annual carbon avoided by the use of the system as follows:

$$\text{CO}_2 \text{ Payback} = \frac{\text{Life cycle embodied CO}_2}{\text{Annual CO}_2 \text{ avoided}} \quad (2)$$

The carbon avoided by Seagen will depend on what generation is displaced and is time and location dependent. Despite this, it is accepted practice to use the average carbon intensity of grid electricity for the calculation of avoided CO₂ with the figure of 0.43kgCO₂/kWh advised by DEFRA [17]. Use of this value suggests generation from Seagen avoids 2036tCO₂ per year indicating a carbon payback period of 8.4 months. The omission of the recycling credit raises the payback period to 11.3 months.

4.3 Comparison with other sources of electricity

The carbon intensity of the Seagen marine current turbine can be compared with other forms of electricity generation technology (Figure 7). It is clear that the Seagen marine current turbine is a significant improvement on fossil fuel electrical generation and compares well with established renewable technologies. Its carbon intensity is significantly lower than that of solar photovoltaic cells and only slightly higher than the 9gCO₂/kWh quoted for large wind turbines sited offshore [12]; similarly its energy payback period (14.6 months) is well within reach of the 8 months quoted for large wind turbines [11]. It should be noted that direct comparison with values from other LCA studies can be problematic, as the assumptions may be different and often non-conservative as well as issues regarding compliance with the ISO standards. Despite this it is clear that given Seagen's relatively early stage of development the results are very encouraging.

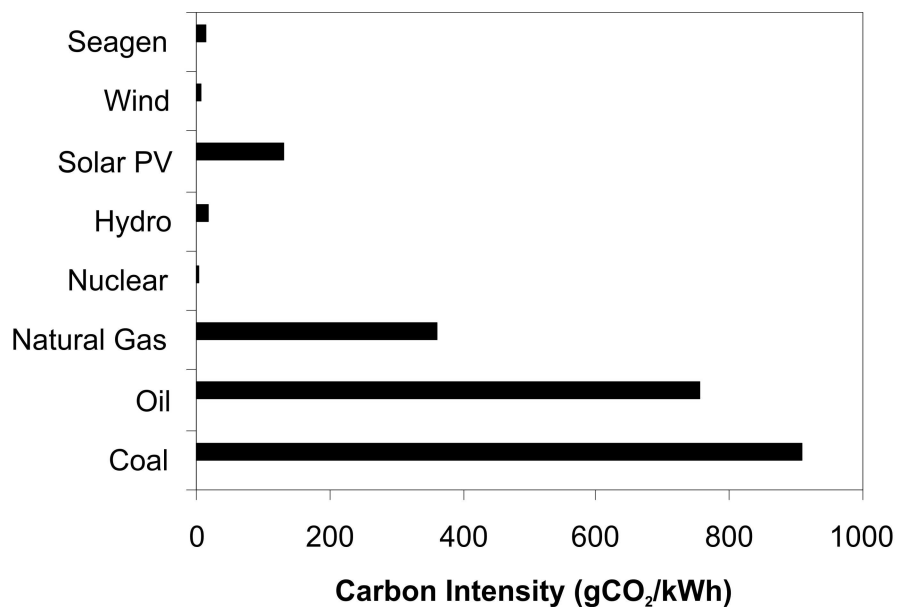

Figure 7. Carbon intensities of energy generating technologies, after [38].

4.4 Sensitivity to assumptions

There are several potential sources of uncertainty in this study arising from non-availability of data. These include the omission of energy or CO₂ emissions associated with certain materials or processes or the assumptions made in response. These exclusions and assumptions have been justified earlier and are not expected to have an impact on the overall results of the analysis or the conclusions drawn. However, there were several factors that could materially affect the results which include: production, design life, recycling rates, the embodied energy and CO₂ of the materials and manufacturing processes, and the installation location. The sensitivity of the environmental performance of Seagen to these factors was examined.

The assumed electrical energy produced by Seagen has a major impact on intensity and payback times as these vary by the same amount. A 10% reduction in production raises carbon intensity to 16.6gCO₂/kWh and energy intensity to 238kJ/kWh; energy and carbon paybacks are lifted by around one and a half and one month, respectively. Relative changes in design life have a similar impact to production changes. The recycling rate for steel was conservatively assumed to be 90% for non-tower components: lowering the rate by ten percentage points alters the performance indicators by around 4% raising carbon intensity to 15.6gCO₂/kWh, energy intensity to 222kJ/kWh and carbon and energy paybacks by one month. Reducing the recovery rate for the tower by the same proportion suggests a further 2% deterioration in performance.

The materials data from the Inventory of Carbon and Energy [18] used in this study are subject to uncertainty; typically ranges for energy values of $\pm 30\%$ are indicated. Extreme scenarios for high and low materials values were examined with the same ranges assumed to apply to carbon intensity. Application of the high materials values raised respective energy and carbon paybacks to 19 and 11 months and intensities to 281kJ/kWh and 19.8gCO₂/kWh. The low materials values gave an energy payback of 10 months and intensity of 147kJ/kWh with a carbon intensity of 10.1gCO₂/kWh and payback of 6 months. Typically, the payback and intensities change slightly more than the change in material value. Further work on the variance of material embodied energy and CO₂ would help greatly in reducing the uncertainty in device environmental performance.

Uncertainties in the materials and manufacturing stage relate to the embodied energy and CO₂ assumptions for the manufacturing processes (e.g., sand-blasting). Their influence was assessed by doubling the estimate of embodied energy and CO₂ for these processes. This resulted in increases of approximately 5% in energy intensity (225kJ/kWh) and 7% in carbon

intensity (16.0gCO₂/kWh). This shows that any error in the data for the manufacturing processes falls well within acceptable tolerances.

Although the installation site is relatively close (50km) to the assembly port, it is conceivable that other projects would be further away. As shipping is known to have a relatively poor environmental performance, and diesel fuel is shown to represent a significant amount of embodied energy and CO₂, the influence of shipping distances was investigated by doubling the distance travelled by vessels and other vehicles during installation, O&M and dismantling. This resulted in increases in energy and carbon intensity of just under 8% to 231kJ/kWh and 16.1gCO₂/kWh, respectively, showing a modest influence.

Overall, the sensitivity study shows that even under the most adverse scenario considered the environmental performance of the Seagen remains excellent and comparable with large commercial wind turbines.

4.5 Potential Improvements

This study has identified the materials, processes and life cycle stages that contribute to energy consumption and CO₂ emissions. The information within it can be used by the manufacturers to assess improvements on environmental performance grounds alongside other factors such as cost, feasibility and aesthetics. To illustrate the potential for reduced environmental impact, several areas have been identified.

Steel is the major source of Seagen's embodied energy and CO₂, which is unsurprising given the benefits of using steel for large structures (e.g., strength, formability and relatively low cost). While increased structural efficiency offers potential savings perhaps the major opportunity lies in capturing greater recycling credit through the recovery and recycling of the entire steel tower at decommissioning: recovery of the entire tower with 90% recycling would lower energy and carbon paybacks to 11.9 months and 6.5 months, respectively, with intensities reduced to 179kJ/kWh and 11.7gCO₂/kWh. Alternative installation methods for the Seagen turbine, such as a short steel tower on a concrete seabed mount [4], may also offer greater energy and carbon efficiencies given the low embodied values for high strength cement (Table 2).

Another opportunity to reduce environmental impact lies with the composites used in the turbine given their disproportionate embodied energy and CO₂ and limited recycling possibilities. Replacement of composite components with less intensive materials may offer savings particularly for less performance-critical elements such as the topside pod.

5 CONCLUSION

This paper presents an analysis of the life cycle energy use and CO₂ emissions associated with the first installation of Seagen tidal current converters. It shows that at 214kJ/Wh and 15gCO₂/kWh, the respective energy and carbon intensities are comparable with large wind turbines and very low relative to fossil-fuelled generation. The energy payback period is approximately 14 months and the CO₂ payback is around 8 months. The materials and manufacturing processes for Seagen are identified as the primary contributors to life cycle embodied energy carbon and improvements in the environmental impact of the Seagen can be achieved by increased material efficiency and alternative installation methods.

6 ACKNOWLEDGEMENTS

The authors are grateful for the assistance of staff at Marine Current Turbines Ltd for their prompt attention and enthusiasm. They also thank Nick Coleman in the Environment Group at Corus for his assistance with steel LCA data. This work was supported by the Scottish Funding Council through the Joint Research Institute in Energy with Heriot-Watt University as part of the Edinburgh Research Partnership.

7 REFERENCES

- [1] **Carbon Trust.** *Future Marine Energy*, 2006 (Carbon Trust, London), available from <http://www.carbontrust.co.uk/Publications/publicationdetail.htm?productid=CTC601>.
- [2] **Elliot, D.** Tidal Energy. In Boyle G. (Ed.), *Renewable Energy*, 2nd Edition, 2006 (Oxford University Press, Oxford).
- [3] **Fraenkel, P. L.** Marine Current Turbines – from prototype to product. In *British Wind Energy Association 28th Annual Conference and Exhibition (BWEA28)*, 10-12 October 2006, Glasgow (BWEA, London).
- [4] **Fraenkel, P. L.** Power from marine currents. *Proceedings of the Institution of Mechanical Engineers, Part A: Journal of Power and Energy*, **216**(1), 2002, 1-14.
- [5] **Banerjee, S., Duckers, L.J., and Blanchard, R.** 2005, 'Development of an Assessment Tool for Wave Energy Systems', World Renewable Energy Congress (WREC2006), 22-27 May 2006, Florence, Italy.
- [6] **Baumann, H. and Tillman, A.M.** *The Hitch Hiker's Guide to LCA: An orientation in LCA methodology and application*, 2004 (Studentlitteratur, Lund, Sweden).
- [7] **International Standards Organisation.** *ISO 14040:2006 Environmental Management – Life Cycle Assessment – Principles and Framework*, 2006 (ISO, Geneva).
- [8] **AEA Technology.** Environmental product declaration of electricity from Torness nuclear power station, May 2005 (British Energy, London).

- [9] **World Energy Council.** *Comparison of Energy Systems Using Life Cycle Assessment*, 2004 (WEC, London).
- [10] **Elsam Engineering A/S.** *Life cycle assessment of offshore and onshore sited wind farms*, 2004 (Elsam, Denmark).
- [11] **Vestas Wind Systems A/S.** *Life cycle assessment of offshore and onshore sited wind power plants based on Vestas V90-3 MW turbines*, 2005 (Vestas, Randers, Denmark).
- [12] **Voorspools, K. R., Brouwers, E. A., and D'haeseleer, W. D.** Energy content and indirect greenhouse gas emissions embedded in 'emission-free' power plants: results for the low countries. *Appl. Energy*, **67**(3), 2000, 307–330.
- [13] **Lenzen, M. and Munksgaard, J.** Energy and CO₂ life-cycle analyses of wind turbines – review and applications. *Renew. Energy*, **26**, 2002, 339-362.
- [14] **Rankine, R. K., Chick, J. P., and Harrison, G. P.** Energy and carbon audit of a rooftop wind turbine. *Proceedings of the Institution of Mechanical Engineers, Part A: Journal of Power and Energy*, **220**(7), 2006, 643-654.
- [15] **Marine Current Turbines Ltd.** *Company website*, 2007, available at www.marineturbines.com (viewed August 2007).
- [16] **Marine Current Turbines Ltd.** *Strangford Lough Marine Current Turbine Environmental Statement*, 2005 (MCT, Bristol).
- [17] **DEFRA.** *Guidelines for Company Reporting on Greenhouse Gas Emissions*, 2005 (Department for Environment, Food and Rural Affairs, London).
- [18] **Hammond, G., and Jones, C.** *Inventory of Carbon & Energy (ICE) - Version 1.5 Beta*, 2006 (Department of Mechanical Engineering, University of Bath, Bath).
- [19] **International Iron and Steel Institute.** *World Steel Life Cycle Inventory Methodology Report (1999/2000)*, 2002 (IISI, Brussels). Available at www.iisi.org.
- [20] **Stodolsky, F., Vyas, A., Cuenca, R., and Gaines, L.** Life-Cycle Energy Savings Potential from Aluminium- Intensive Vehicles. In *Total Life Cycle Conference and Exposition*, 16-19 October 1995, Vienna, Austria.
- [21] **Ryyd C. J. and Sun M.** *Life cycle inventory data for materials grouped according to environmental and material properties.* *J. Clean. Prod.*, **13**, 2005,1258-1268.
- [22] **Association of Plastics Manufacturers.** *Eco-Profiles of European Plastics*, 2007 (PlasticsEurope, Brussels), online datasets available at www.plasticseurope.org.
- [23] **Suzuki, T. and Takahashi, J.** Prediction of energy intensity of carbon fibre reinforced plastics for mass-produced passenger cars. In *9th Japan International SAMPE Symposium JISSE-9*, 29 November-2 December 2005, Tokyo, Japan.
- [24] **Jivén, K., Sjöbris, A., Nilsson, M., Ellis, J., Trägårdh, P., and Nordström, M.** *LCA-ship, Design tool for energy efficient ships - A Life Cycle Analysis Program for Ships*, 2004, Final Report: 2004-08-27 (Mariterm AB, Gothenburg, Sweden).

- [25] **Dahmus, J., and Gutowski, G.** An environmental analysis of machining. In *ASME International Mechanical Engineering Congress and RD&D Exposition*, 13-19 November 2004, Anaheim, CA, USA.
- [26] **Årskog, V., Fossdal, S., and Gjørsv., O.E.** Life cycle assessment of repair and maintenance systems for concrete structures. In *Proc. International Workshop on Sustainable Development and Concrete Technology*, 20–21 May, 2004, Beijing, China, pp. 193-200.
- [27] **Dalquist, S. and Gutowski, T.** Life cycle analysis of conventional manufacturing techniques: Sand casting. In *AMSE International Mechanical Engineering Congress & RD&D Exposition*, 13-19 November 2004, Anaheim, CA, USA.
- [28] **ABB Automation.** *Environmental Product Declaration: AC machine type HXR 355, 250 kW power*, 2003 (ABB Machines, Helsinki, Finland), available from http://search.abb.com/library/ABBLibrary.asp?DocumentID=FIEPD_3BFP000013R0101&LanguageCode=en&DocumentPartId=&Action=Launch.
- [29] **ABB Drives.** *Environmental Product Declaration: 630 kW Low Voltage AC Drive Frequency Converter*, 2003 (ABB Oy Drives, Helsinki, Finland), available from <http://search.abb.com/library/ABBLibrary.asp?DocumentID=3AFE64726536&LanguageCode=en&DocumentPartID=1&Action=Launch>.
- [30] **ABB Distribution Transformers.** *Environmental Product Declaration: Distribution Transformer 315kVA*, 2007 (ABB Australia Pty Ltd, Queensland, Australia), available from http://search.abb.com/library/ABBLibrary.asp?DocumentID=AUEPD_001&LanguageCode=en&DocumentPartId=&Action=Launch.
- [31] **ABB Electrical Machines.** Environmental Product Declaration: AC Low voltage flameproof motor, type M3JP, 2002 (ABB Oy Electrical Machines, Vassa, Finland), available at:
http://search.abb.com/library/ABBLibrary.asp?DocumentID=FIEPD_M3JP180_GB052002_3GZF500918_25&LanguageCode=en&DocumentPartId=&Action=Launch
- [32] **ABB Automation Technologies.** *Environmental Product Declaration: AC 800M Programmable Industrial Controller*, 2005 (ABB Automation Technologies, Västerås, Sweden), available from <http://search.abb.com/library/ABBLibrary.asp?DocumentID=EPD-CPMS-01&LanguageCode=en&DocumentPartId=&Action=Launch>
- [33] **Anonymous.** Dogancay V Simple 40 tonne bollard pull tug boat. *Work Boat World*, December 2002, 25.
- [34] **Maritime Craft Services (Clyde) Ltd.** *Technical specifications for fleet of workboats* (MCS, Largs, Ayrshire), available from www.maritimecraft.co.uk.
- [35] **McNallys Crane Specialists.** *Personal communication*, 2006.

- [36] **Brimacombe, L., Shonfield, P., and Buridard, M.** Sustainability and Steel Recycling, *Proc 2001 Environmental Sustainability Conference and Exhibition*, Nov 12-14 2001, Graz, Austria.
- [37] **International Aluminium Institute.** *Life cycle inventory of the worldwide aluminium industry with regard to energy consumption and emissions of greenhouse gases*, March 2003 (IAI, London), available from www.world-aluminium.org.
- [38] **Parliamentary Office of Science and Technology.** *Carbon Footprint of Electricity Generation – Postnote 268*, October 2006 (POST, London).