

8-22-2016

Midwest Guardrail System (MGS) Placed Adjacent to a 1V:2H Fill Slope with 6-ft Posts

Austin J. Haase

University of Nebraska - Lincoln

Justine E. Kohtz

University of Nebraska - Lincoln

Karla A. Lechtenberg

University of Nebraska-Lincoln, kpolivka2@unl.edu

John D. Reid

University of Nebraska - Lincoln, jreid@unl.edu

Ronald K. Faller

University of Nebraska - Lincoln, rfaller1@unl.edu

Follow this and additional works at: <http://digitalcommons.unl.edu/ndor>



Part of the [Transportation Engineering Commons](#)

Haase, Austin J.; Kohtz, Justine E.; Lechtenberg, Karla A.; Reid, John D.; and Faller, Ronald K., "Midwest Guardrail System (MGS) Placed Adjacent to a 1V:2H Fill Slope with 6-ft Posts" (2016). *Nebraska Department of Transportation Research Reports*. 145.
<http://digitalcommons.unl.edu/ndor/145>

This Article is brought to you for free and open access by the Nebraska LTAP at DigitalCommons@University of Nebraska - Lincoln. It has been accepted for inclusion in Nebraska Department of Transportation Research Reports by an authorized administrator of DigitalCommons@University of Nebraska - Lincoln.



TESTING CERT # 2937.01

*Midwest States Regional Pooled Fund Research Program
Fiscal Year 2013 (Year 24)
Research Project Number TPF-5(193) Supplemental #68
NDOR Sponsoring Agency Code RFPF-14-MGS-8*

MIDWEST GUARDRAIL SYSTEM (MGS) WITH 6-FT POSTS PLACED ADJACENT TO A 1V:2H FILL SLOPE

Submitted by

Austin J. Haase
Former Undergraduate Research Assistant

Justine E. Kohtz
Research Assistant

Karla A. Lechtenberg, M.S.M.E., E.I.T.
Research Associate Engineer

Robert W. Bielenberg, M.S.M.E., E.I.T.
Research Associate Engineer

John D. Reid, Ph.D., P.E.
Professor

Ronald K. Faller, Ph.D., P.E.
Research Associate Professor
MwRSF Director

MIDWEST ROADSIDE SAFETY FACILITY

Nebraska Transportation Center
University of Nebraska-Lincoln
130 Whittier Research Center
2200 Vine Street
Lincoln, Nebraska 68583-0853
(402) 472-0965

Submitted to

MIDWEST STATES REGIONAL POOLED FUND PROGRAM

Nebraska Department of Roads
1500 Nebraska Highway 2
Lincoln, Nebraska 68502

MwRSF Research Report No. TRP-03-320-16

August 22, 2016

TECHNICAL REPORT DOCUMENTATION PAGE

1. Report No. TRP-03-320-16	2.	3. Recipient's Accession No.	
4. Title and Subtitle Midwest Guardrail System (MGS) Placed Adjacent to a 1V:2H Fill Slope with 6-ft Posts		5. Report Date August 22, 2016	
		6.	
7. Author(s) Haase, A.J., Kohtz, J.E., Lechtenberg, K.A., Bielenberg, R.W., Reid, J.D., and Faller, R.K.		8. Performing Organization Report No. TRP-03-320-16	
9. Performing Organization Name and Address Midwest Roadside Safety Facility (MwRSF) Nebraska Transportation Center University of Nebraska-Lincoln 130 Whittier Research Center 2200 Vine Street Lincoln, Nebraska 68583-0853		10. Project/Task/Work Unit No.	
		11. Contract © or Grant (G) No. TPF-5(193) Supplemental #68	
12. Sponsoring Organization Name and Address Midwest States Regional Pooled Fund Program Nebraska Department of Roads 1500 Nebraska Highway 2 Lincoln, Nebraska 68502		13. Type of Report and Period Covered Final Report: 2013-2016	
		14. Sponsoring Agency Code RPPFP-14-MGS-8	
15. Supplementary Notes Prepared in cooperation with U.S. Department of Transportation, Federal Highway Administration.			
16. Abstract <p>The Midwest Guardrail System (MGS) has previously been approved for placement on the slope break point of a 1V:2H fill slope if 9-ft (2.7-m) steel posts are used. In order to reduce hardware inventories, states have chosen in some cases to install the standard MGS system at a lateral offset away from the slope break point. Current guidance requires minimum offsets ranging between 1 ft (0.3 m) and 2 ft (0.6 m) from the back of the post to the slope break point for the standard MGS system with 6-ft (1.8-m) long posts, depending on the slope grade. The goal of this research was to evaluate if standard length posts could be placed adjacent to a 1V:2H fill slope while maintaining satisfactory safety performance under the <i>Manual for Assessing Safety Hardware</i> (MASH) TL-3 conditions.</p> <p>The MGS was crash tested with W6x8.5 (W152x12.6) steel posts measuring 72 in. (1,829 mm) long. This system used a 6-in. wide x 12-in. deep x 14½-in. long (152-mm x 305-mm x 368-mm) Southern Yellow Pine wood blockout as well as 12-gauge (2.66-mm) guardrail sections. The design was evaluated using a 5,158-lb (2,340-kg) Dodge Ram 1500 quad-cab pickup truck impacting at 61.6 mph (99.1 km/hr) and 26.3 degrees. The MGS placed adjacent to a 1V:2H fill slope met the MASH safety requirements for the full-scale crash test. Following the full-scale crash testing, recommendations were given regarding the use of standard-length steel posts when MGS systems are installed at the slope break point of a 1V:2H slope.</p>			
17. Document Analysis/Descriptors Highway Safety, Crash Test, Roadside Appurtenances, Compliance Test, MASH, MGS, Guardrail, 1V:2H Fill Slope, Non-Proprietary, Steel Posts		18. Availability Statement No restrictions. Document available from: National Technical Information Services, Springfield, Virginia 22161	
19. Security Class (this report) Unclassified	20. Security Class (this page) Unclassified	21. No. of Pages 135	22. Price

DISCLAIMER STATEMENT

This report was completed with funding from the Federal Highway Administration, U.S. Department of Transportation as well as the Midwest States Pooled Fund Program. The contents of this report reflect the views and opinions of the authors who are responsible for the facts and the accuracy of the data presented herein. The contents do not necessarily reflect the official views or policies of the state highway departments participating in the Midwest States Regional Pooled Fund Program nor the Federal Highway Administration, U.S. Department of Transportation. This report does not constitute a standard, specification, regulation, product endorsement, or an endorsement of manufacturers.

UNCERTAINTY OF MEASUREMENT STATEMENT

The Midwest Roadside Safety Facility (MwRSF) has determined the uncertainty of measurements for several parameters involved in standard full-scale crash testing and non-standard testing of roadside safety features. Information regarding the uncertainty of measurements for critical parameters is available upon request by the sponsor and the Federal Highway Administration.

INDEPENDENT APPROVING AUTHORITY

The Independent Approving Authority (IAA) for the data contained herein was Mr. Cody Stolle, Research Associate Engineer.

ACKNOWLEDGEMENTS

The authors wish to acknowledge several sources that made a contribution to this project: (1) the Midwest States Regional Pooled Fund Program funded by the Illinois Department of Transportation, Indiana Department of Transportation, Iowa Department of Transportation, Kansas Department of Transportation, Minnesota Department of Transportation, Missouri Department of Transportation, Nebraska Department of Roads, New Jersey Department of Transportation, Ohio Department of Transportation, South Dakota Department of Transportation, Wisconsin Department of Transportation, and Wyoming Department of Transportation for sponsoring this project; and (2) MwRSF personnel for constructing the barrier and conducting the crash test.

Acknowledgement is also given to the following individuals who made a contribution to the completion of this research project.

Midwest Roadside Safety Facility

J.C. Holloway, M.S.C.E., E.I.T., Test Site Manager
S.K. Rosenbaugh, M.S.C.E., E.I.T., Research Associate Engineer
J.D. Schmidt, Ph.D., P.E., Post-Doctoral Research Associate
C.S. Stolle, Ph.D., Post-Doctoral Research Associate
A.T. Russell, B.S.B.A., Shop Manager
K.L. Krenk, B.S.M.A., Maintenance Mechanic (retired)
S.M. Tighe, Laboratory Mechanic
D.S. Charroin, Laboratory Mechanic
M.A. Rasmussen, Laboratory Mechanic
E.W. Krier, Laboratory Mechanic
Undergraduate and Graduate Research Assistants

Illinois Department of Transportation

Priscilla A. Tobias, P.E., State Safety Engineer/Bureau Chief
Tim Sheehan, P.E., Safety Design Engineer
Paul L. Lorton, P.E., Safety Programs Unit Chief

Indiana Department of Transportation

Todd Shields, P.E., Maintenance Field Support Manager

Iowa Department of Transportation

Chris Poole, P.E., Roadside Safety Engineer
Brian Smith, P.E., Methods Engineer

Kansas Department of Transportation

Ron Seitz, P.E., Bureau Chief
Scott King, P.E., Road Design Bureau Chief
Kelly Keele, P.E., Road Design Leader
Thomas Rhoads, P.E., Engineering Associate III, Bureau of Road Design

Minnesota Department of Transportation

Michael Elle, P.E., Design Standards Engineer

Missouri Department of Transportation

Ronald Effland, P.E., ACTAR, LCI, Non-Motorized Transportation Engineer
Joseph G. Jones, P.E., former Engineering Policy Administrator

Nebraska Department of Roads

Phil TenHulzen, P.E., Design Standards Engineer
Jim Knott, P.E., State Roadway Design Engineer
Jodi Gibson, Research Coordinator

New Jersey Department of Transportation

Dave Bizuga, Manager 2, Roadway Design Group 1

Ohio Department of Transportation

Don Fisher, P.E., Roadway Standards Engineer
Maria E. Ruppe, P.E., former Roadway Standards Engineer

South Dakota Department of Transportation

David Huft, P.E., Research Engineer
Bernie Clocksin, P.E., Lead Project Engineer

Wisconsin Department of Transportation

Jerry Zogg, P.E., Chief Roadway Standards Engineer
Erik Emerson, P.E., Standards Development Engineer
Rodney Taylor, P.E., Roadway Design Standards Unit Supervisor

Wyoming Department of Transportation

William Wilson, P.E., Architectural and Highway Standards Engineer

Federal Highway Administration

John Perry, P.E., Nebraska Division Office

Danny Briggs, Nebraska Division Office

TABLE OF CONTENTS

TECHNICAL REPORT DOCUMENTATION PAGE i

DISCLAIMER STATEMENT ii

UNCERTAINTY OF MEASUREMENT STATEMENT ii

INDEPENDENT APPROVING AUTHORITY..... ii

ACKNOWLEDGEMENTS iii

TABLE OF CONTENTS..... vi

LIST OF FIGURES viii

LIST OF TABLES x

1 INTRODUCTION 1

 1.1 Background 1

 1.2 Objective 2

 1.3 Scope..... 2

2 DESIGN DETAILS 3

3 TEST REQUIREMENTS AND EVALUATION CRITERIA 19

 3.1 Test Requirements 19

 3.2 Evaluation Criteria 20

 3.3 Soil Strength Requirements 21

4 TEST CONDITIONS..... 23

 4.1 Test Facility 23

 4.2 Vehicle Tow and Guidance System 23

 4.3 Test Vehicles..... 23

 4.4 Simulated Occupant 28

 4.5 Data Acquisition Systems 28

 4.5.1 Accelerometers 28

 4.5.2 Rate Transducers..... 28

 4.5.3 Retroreflective Optic Speed Trap 29

 4.5.4 Load Cells 29

 4.5.5 Digital Photography 31

5 FULL-SCALE CRASH TEST NO. MGSS-1 33

 5.1 Static Soil Test 33

 5.2 Weather Conditions 33

 5.3 Test No. MGSS-1..... 33

 5.4 Test Description 34

 5.5 Barrier Damage..... 35

 5.6 Vehicle Damage..... 36

5.7 Occupant Risk..... 38
5.8 Load Cells 39
5.9 Discussion..... 39

6 SUMMARY, CONCLUSIONS, AND RECOMMENDATIONS 53

7 IMPLEMENTATION GUIDANCE 56

 7.1 Soil Foundation..... 56
 7.2 Minimum Installation Height..... 59
 7.3 MGS Long-Span Guardrail..... 60
 7.4 MGS with an Omitted Post..... 61
 7.5 MGS on 8:1 Approach Slopes 62
 7.6 MGS Adjacent to Curb 63
 7.7 MGS Stiffness Transition to Approach Guardrail Transitions 63
 7.8 MGS with Reduced Post Spacing..... 65
 7.9 MGS without Blockouts 65
 7.10 MGS with Wood Posts 66
 7.11 Guardrail End Terminals..... 69

8 REFERENCES 71

9 APPENDICES 76

 Appendix A. Material Specifications, Test No. MGSS-1 77
 Appendix B. Vehicle Center of Gravity Determination, Test No. MGSS-1..... 103
 Appendix C. Static Soil Tests, Test No. MGSS-1 105
 Appendix D. Vehicle Deformation Records, Test No. MGSS-1 108
 Appendix E. Accelerometer and Rate Transducer Data Plots, Test No. MGSS-1 115
 Appendix F. Load Cell Data, Test No. MGSS-1 132

LIST OF FIGURES

Figure 1. Test Installation Layout, Test No. MGSS-1	5
Figure 2. Post Details, Test No. MGSS-1	6
Figure 3. End Section and Splice Detail, Test No. MGSS-1	7
Figure 4. BCT Anchor Details, Test No. MGSS-1	8
Figure 5. Line Post and Blockout Details, Test No. MGSS-1	9
Figure 6. BCT Timber Post and Foundation Tube Details, Test No. MGSS-1	10
Figure 7. BCT Post Components and Anchor Bracket, Test No. MGSS-1	11
Figure 8. Ground Strut Details, Test No. MGSS-1	12
Figure 9. BCT Anchor Cable, Test No. MGSS-1	13
Figure 10. Fasteners, Test No. MGSS-1	14
Figure 11. Rail Section Details, Test No. MGSS-1	15
Figure 12. Bill of Materials, Test No. MGSS-1	16
Figure 13. Test Installation Photographs, Test No. MGSS-1	17
Figure 14. Test Installation Photographs, Test No. MGSS-1	18
Figure 15. Test Vehicle, Test No. MGSS-1	24
Figure 16. Vehicle Dimensions, Test No. MGSS-1	25
Figure 17. Target Geometry, Test No. MGSS-1	27
Figure 18. Load Cell Placement, Test No. MGSS-1	30
Figure 19. Camera Locations, Speeds, and Lens Settings, Test No. MGSS-1	32
Figure 20. Summary of Test Results and Sequential Photographs, Test No. MGSS-1	40
Figure 21. Additional Sequential Photographs, Test No. MGSS-1	41
Figure 22. Additional Sequential Photographs, Test No. MGSS-1	42
Figure 23. Additional Sequential Photographs, Test No. MGSS-1	43
Figure 24. Impact Location, Test No. MGSS-1	44
Figure 25. Vehicle Final Position and Trajectory Marks, Test No. MGSS-1	45
Figure 27. System Damage, Test No. MGSS-1	47
Figure 28. System Damage Between Post Nos. 12 and 17, Test No. MGSS-1	48
Figure 29. Post Damage Between Post Nos. 12 and 15, Test No. MGSS-1	49
Figure 30. Post Damage Between Post Nos. 15 and 18, Test No. MGSS-1	50
Figure 31. Upstream and Downstream Anchor Damage, Test No. MGSS-1	51
Figure 32. Vehicle Damage, Test No. MGSS-1	52
Figure 33. MGS Adjacent to a 1V:2H Slope Offset from W-to-Thrie Beam Transition	65
Figure 34. MGS Adjacent to a 1V:2H Slope without Blockouts	66
Figure 35. MGS Adjacent to a 1V:2H Slope with SYP Rectangular Posts	69
Figure A-1. Bill of Materials, Test No. MGSS-1	78
Figure A-2. Steel Posts, Test No. MGSS-1	79
Figure A-3. Wood Blockouts, Test No. MGSS-1	80
Figure A-4. 16D Double Head Nail, Test No. MGSS-1	81
Figure A-5. MGS W-Beam 12-ft – 6-in. (3.8-m) Section, Test No. MGSS-1	82
Figure A-6. MGS W-Beam 12-ft – 6-in. (3.8-m) Section, Test No. MGSS-1	83
Figure A-7. MGS W-Beam 6-ft – 3-in. (1.9-m) Section, Test No. MGSS-1	84
Figure A-8. MGS W-Beam End Section, Test No. MGSS-1	85
Figure A-9. BCT Timber Posts, Test No. MGSS-1	86
Figure A-10. Foundation Tubes, Test No. MGSS-1	87

Figure A-11. Strut and Yoke Assembly, Test No. MGSS-1.....	88
Figure A-12. Anchor Bracket Assembly, Test No. MGSS-1	89
Figure A-13. Anchor Bearing Plate, Test No. MGSS-1	90
Figure A-14. BCT Post Sleeve, Test No. MGSS-1.....	91
Figure A-15. 5/8 in. Dia. UNC, 14 in. Long Guardrail Bolt, Test No. MGSS-1.....	92
Figure A-16. 5/8 in. Dia. UNC, 14 in. Long Guardrail Bolt, Test No. MGSS-1.....	93
Figure A-17. 5/8 in. Dia. UNC, 1¼ in. Guardrail Bolt, Test No. MGSS-1	94
Figure A-18. 5/8 in. Dia. UNC, Guardrail Nut, Test No. MGSS-1	95
Figure A-19. 5/8 in. Dia. UNC, 10 in. Long Guardrail Bolt, Test No. MGSS-1.....	96
Figure A-20. 5/8 in. Dia. UNC, 10 in. Long Hex Head Bolt, Test No. MGSS-1	97
Figure A-21. 5/8 in. Dia. UNC, 1¼ in. Long Hex Head Bolt, Test No. MGSS-1	98
Figure A-22. 7/8 in. Dia. UNC, 8 in. Long Hex Head Bolt, Test No. MGSS-1	99
Figure A-23. 7/8 in. Dia. UNC, Hex Head Nut, Test No. MGSS-1	100
Figure A-24. 5/8 in. Dia. Plain Round Washer, Test No. MGSS-1	101
Figure A-25. 7/8 in. Dia. Plain Round Washer, Test No. MGSS-1	102
Figure B-1. Vehicle Mass Distribution, Test No. MGSS-1	104
Figure C-1. Soil Strength, Initial Calibration Tests, Test No. MGSS-1	106
Figure C-2. Static Soil Test S2, Test No. MGSS-1	107
Figure D-1. Floorpan Deformation Data – Set 1, Test No. MGSS-1	109
Figure D-2. Floorpan Deformation Data – Set 2, Test No. MGSS-1	110
Figure D-3. Occupant Compartment Deformation Data – Set 1, Test No. MGSS-1	111
Figure D-4. Occupant Compartment Deformation Data – Set 2, Test No. MGSS-1	112
Figure D-5. Exterior Vehicle Crush (NASS) - Front, Test No. MGSS-1	113
Figure D-6. Exterior Vehicle Crush (NASS) - Side, Test No. MGSS-1	114
Figure E-1. 10-ms Average Longitudinal Deceleration (SLICE-1), Test No. MGSS-1.....	116
Figure E-2. Longitudinal Occupant Impact Velocity (SLICE-1), Test No. MGSS-1	117
Figure E-3. Longitudinal Occupant Displacement (SLICE-1), Test No. MGSS-1	118
Figure E-4. 10-ms Average Lateral Deceleration (SLICE-1), Test No. MGSS-1	119
Figure E-5. Lateral Occupant Impact Velocity (SLICE-1), Test No. MGSS-1.....	120
Figure E-6. Lateral Occupant Displacement (SLICE-1), Test No. MGSS-1.....	121
Figure E-7. Vehicle Angular Displacements (SLICE-1), Test No. MGSS-1	122
Figure E-8. Acceleration Severity Index (SLICE-1), Test No. MGSS-1	123
Figure E-9. 10-ms Average Longitudinal Deceleration (SLICE-2), Test No. MGSS-1.....	124
Figure E-10. Longitudinal Occupant Impact Velocity (SLICE-2), Test No. MGSS-1	125
Figure E-11. Longitudinal Occupant Displacement (SLICE-2), Test No. MGSS-1	126
Figure E-12. 10-ms Average Lateral Deceleration (SLICE-2), Test No. MGSS-1	127
Figure E-13. Lateral Occupant Impact Velocity (SLICE-2), Test No. MGSS-1.....	128
Figure E-14. Lateral Occupant Displacement (SLICE-2), Test No. MGSS-1.....	129
Figure E-15. Vehicle Angular Displacements (SLICE-2), Test No. MGSS-1	130
Figure E-16. Acceleration Severity Index (SLICE-2), Test No. MGSS-1	131
Figure F-1. Upstream Load Cell Data, Test No. MGSS-1.....	133
Figure F-2. Upstream Inline Load Cell Data, Test No. MGSS-1	134

LIST OF TABLES

Table 1. MASH TL-3 Crash Test Conditions20
Table 2. MASH Evaluation Criteria for Longitudinal Barrier.....22
Table 3. Weather Conditions, Test No. MGSS-133
Table 4. Sequential Description of Impact Events, Test No. MGSS-1.....34
Table 5. Maximum Occupant Compartment Deformations by Location37
Table 6. Summary of OIV, ORA, THIV, PHD, and ASI Values, Test No. MGSS-138
Table 7. Summary of Safety Performance Evaluation Results.....54
Table 8. Comparison of MGS with 9-ft (2.7 m) and 6-ft (1.8 m) Long Posts55

1 INTRODUCTION

1.1 Background

W-beam guardrail may be used to protect motorists from steep roadside slopes adjacent to high-speed roadways. A roadside slope placed immediately behind a guardrail system greatly reduces the soil resistance associated with lateral deflection of the barrier. This reduction in the post-soil forces greatly reduces a system's energy-absorption capability, significantly increases dynamic rail deflections, and can potentially induce issues with vehicle capture or vehicle override. Further, when the guardrail extends over the embankment, the gap between the bottom of the rail and the ground will be greatly magnified and thereby increase the risk of severe wheel snag and potential small car underride.

The Midwest Guardrail System (MGS) has greatly improved the safety performance and stability of guardrail installed at the slope break point of slopes as steep as 1V:2H. However, current MGS installations adjacent to 1V:2H fill slopes utilize increased-length posts in order to provide sufficient embedment to generate the proper soil resistive forces[1-5]. This requirement creates hardware inventory and maintenance issues within state departments of transportation, due to the need to stock and maintain non-standard length posts. In order to reduce hardware inventories, states have chosen in some cases to install the standard MGS system at an offset from the slope. Current guidance requires minimum offsets of between 1 ft (0.3 m) and 2 ft (0.6 m) from the back of the post to the slope break point for the standard MGS system with 6-ft (1.8-m) long posts, depending on the slope grade. This large offset maintains the safety performance of the system but creates a great deal of additional expense in terms of earthwork. Thus, a need exists to evaluate a minimum offset for the standard MGS guardrail system adjacent to a 1V:2H fill slope in order to reduce current issues with state hardware inventories and maintenance costs.

1.2 Objective

The objective of this research was to determine the crashworthiness of the standard MGS, installed at the slope break point of a 1V:2H slope. The system was to meet the Test Level 3 (TL-3) safety performance criteria set forth in American Association of State Highway and Transportation Officials' *Manual for Assessing Safety Hardware* (MASH) [6].

1.3 Scope

The research objective was completed by accomplishing several tasks. First, a full-scale crash test was conducted on the MGS placed at the slope break point of a 1V:2H fill slope. The crash test consisted of a pickup truck weighing approximately 5,000 lb (2,268 kg) impacting at a target of 62 mph (100 km/h) and 25 degrees. Next, the test results were analyzed, evaluated, and documented. Finally, conclusions and recommendations were made that pertain to the safety performance of the standard MGS placed at the slope break point of a 1V:2H fill slope.

2 DESIGN DETAILS

The MGS installed at the slope break point of a 1V:2H slope consisted of 175 ft (53.3 m) of standard 12-gauge (2.7-mm thick) W-beam guardrail with a top rail mounting height of 31 in. (787 mm) supported by steel posts, as shown in Figure 2. Non-proprietary MGS trailing end anchorage systems [7-9] were utilized on both the upstream and downstream ends of the guardrail system. Design details are shown in Figures 1 through 12. Photographs of the test installation are shown in Figure 13. Material specifications, mill certifications, and certificates of conformity for the system materials are shown in Appendix A.

The system was constructed with 29 posts. Post nos. 3 through 27 were galvanized ASTM A992, W6x8.5 (W152x12.6) steel sections measuring 72 in. (1,829 mm) long. Post nos. 1, 2, 28, and 29 were 5½-in. wide x 7½-in. deep x 46-in. long (140-mm x 191-mm x 1,168-mm) BCT timber posts. The anchor posts were placed into 6-in. x 8-in. x 72-in. long (152-mm x 203-mm x 1,829-mm), ASTM A53 Grade B, steel foundation tubes, as shown in Figures 3 and 6. All posts were spaced 75 in. (1,905 mm) on center and placed in a compacted, coarse, crushed limestone material, as recommended by MASH [6]. Post nos. 3 through 27 had an embedment depth of 40 in. (1,016 mm). A 6-in. x 12-in. x 14½-in. long (152-mm x 305-mm x 368-mm) Southern Yellow Pine wood blockout was used to block the rail away from the front face of each steel post, as shown in Figure 5.

Standard 12-gauge (2.7-mm thick) W-beam rails with additional post bolt slots at half-post spacing intervals were mounted on post nos. 1 through 29. The W-beam had a 24⅞-in. (632-mm) center mounting height. Rail splices were located at midspans between posts, as shown in Figure 3. The lap splice connections between the rail sections were configured to reduce vehicle snag potential at the splice during the crash test.

A load cell assembly was spliced into the upstream anchorage anchor cables to measure the loads experienced during full-scale crash testing. The use of these load cell assemblies was purely research orientated, with the purpose of analyzing the anchors' performance.

A 1V:2H fill slope pit was dug behind post nos. 9 through 20, as shown in Figures 1, 2, and 13. The pit was 120 in. (3,048 mm) wide and 60 in. (1,524 mm) deep. The length of the pit was 75 ft (22.9 m), spanning from the midspan between post nos. 8 and 9 to the midspan between post nos. 20 and 21.

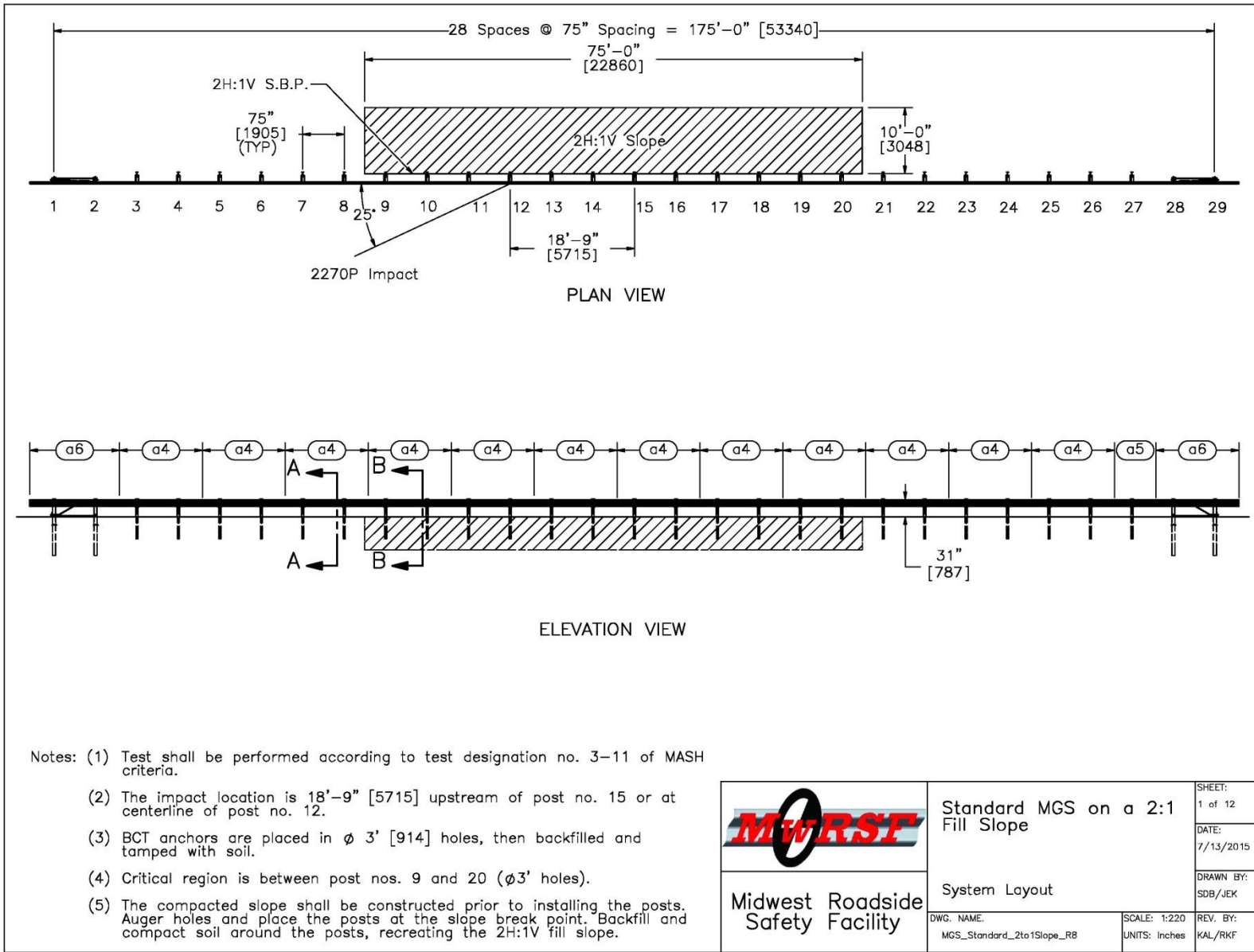

5

Figure 1. Test Installation Layout, Test No. MGSS-1

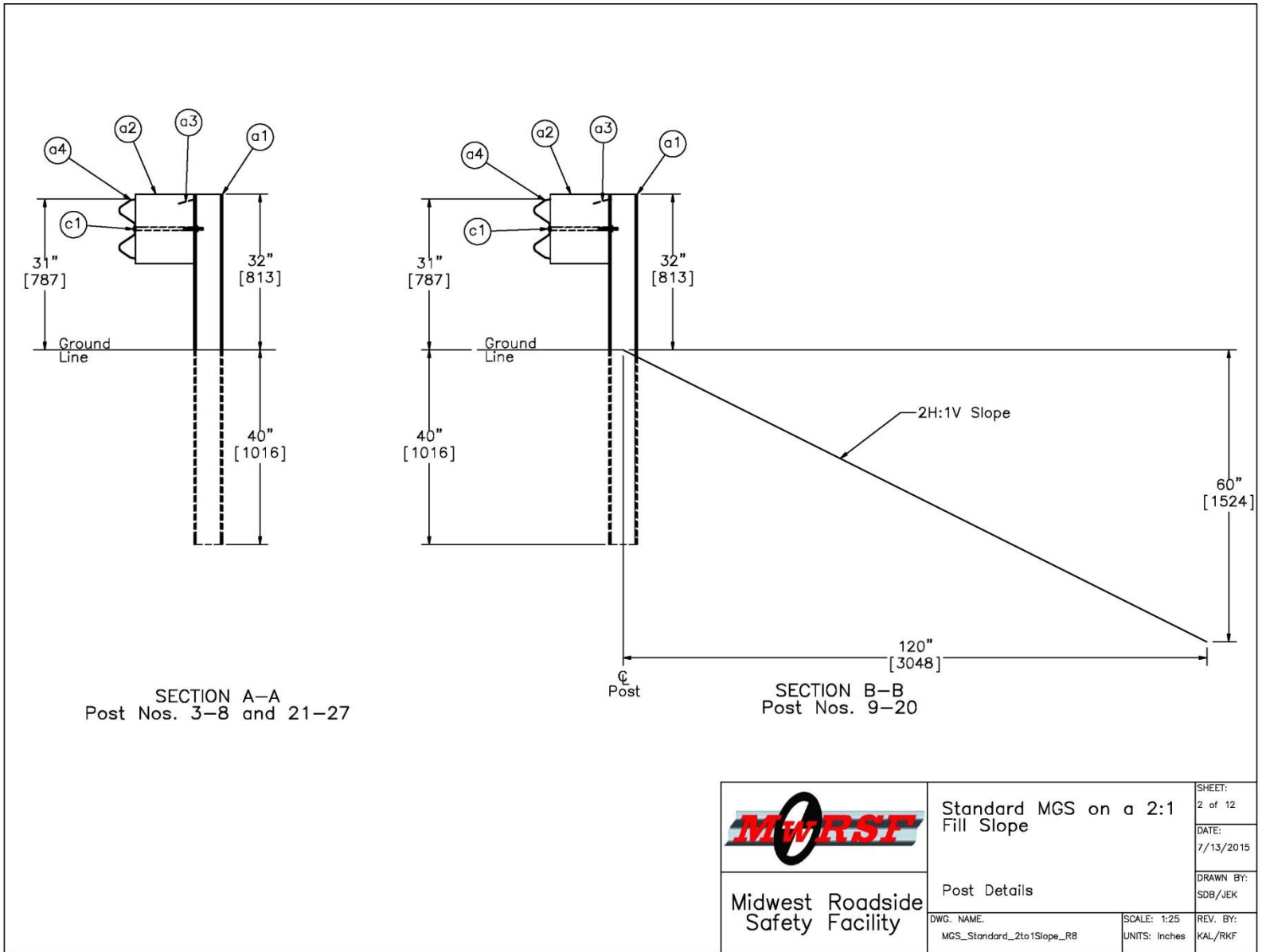

Figure 2. Post Details, Test No. MGSS-1

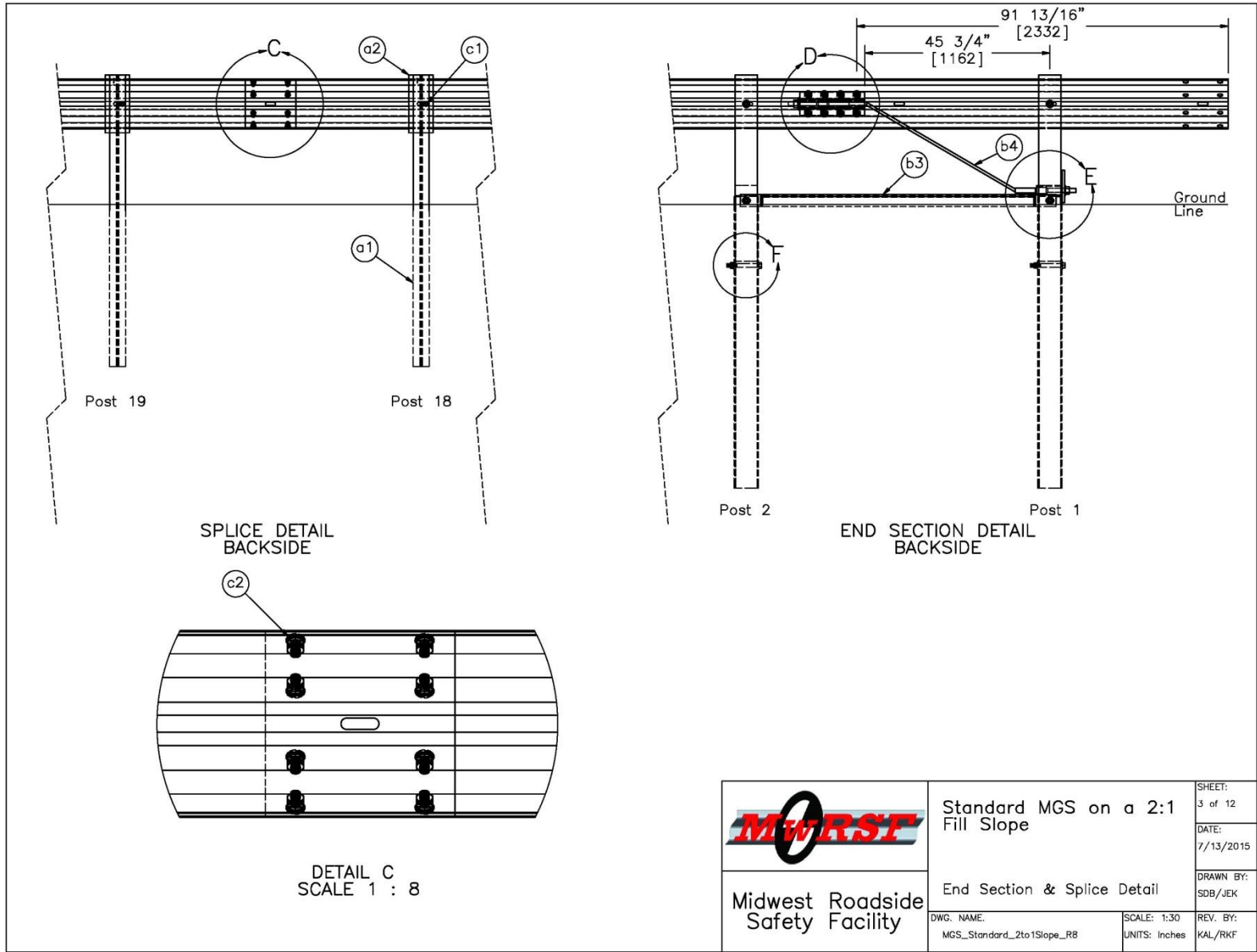

Figure 3. End Section and Splice Detail, Test No. MGSS-1

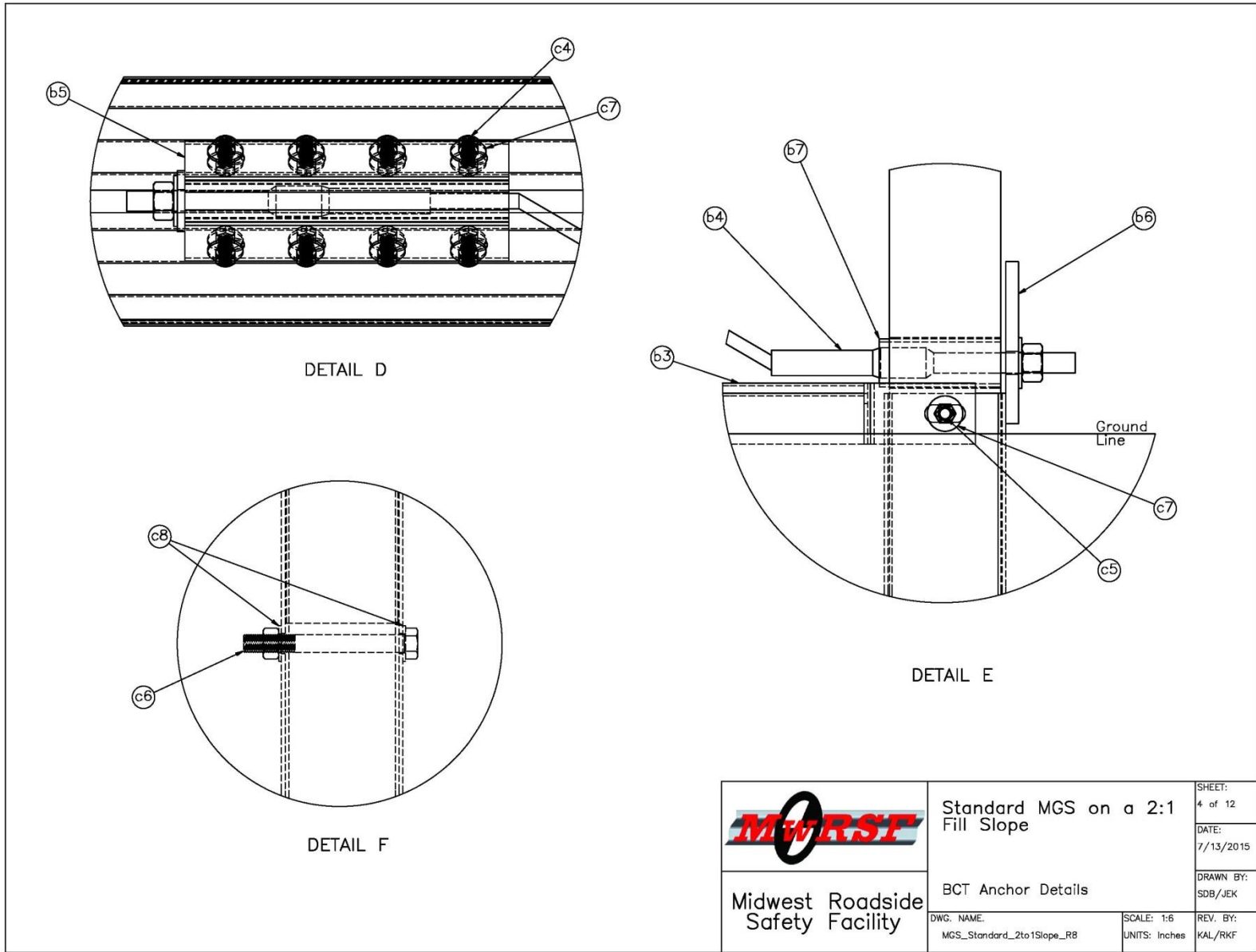

Figure 4. BCT Anchor Details, Test No. MGSS-1

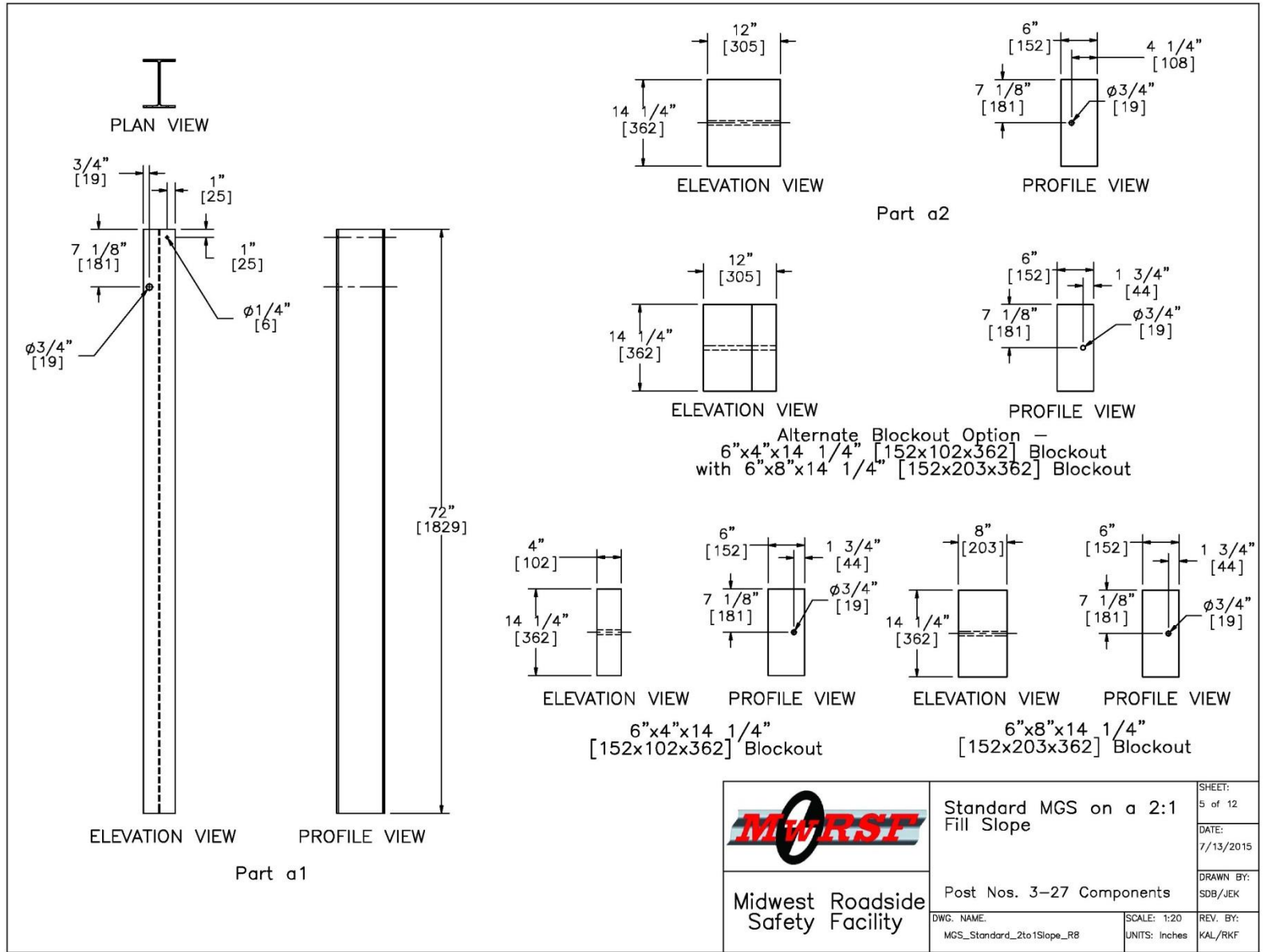

Figure 5. Line Post and Blockout Details, Test No. MGSS-1

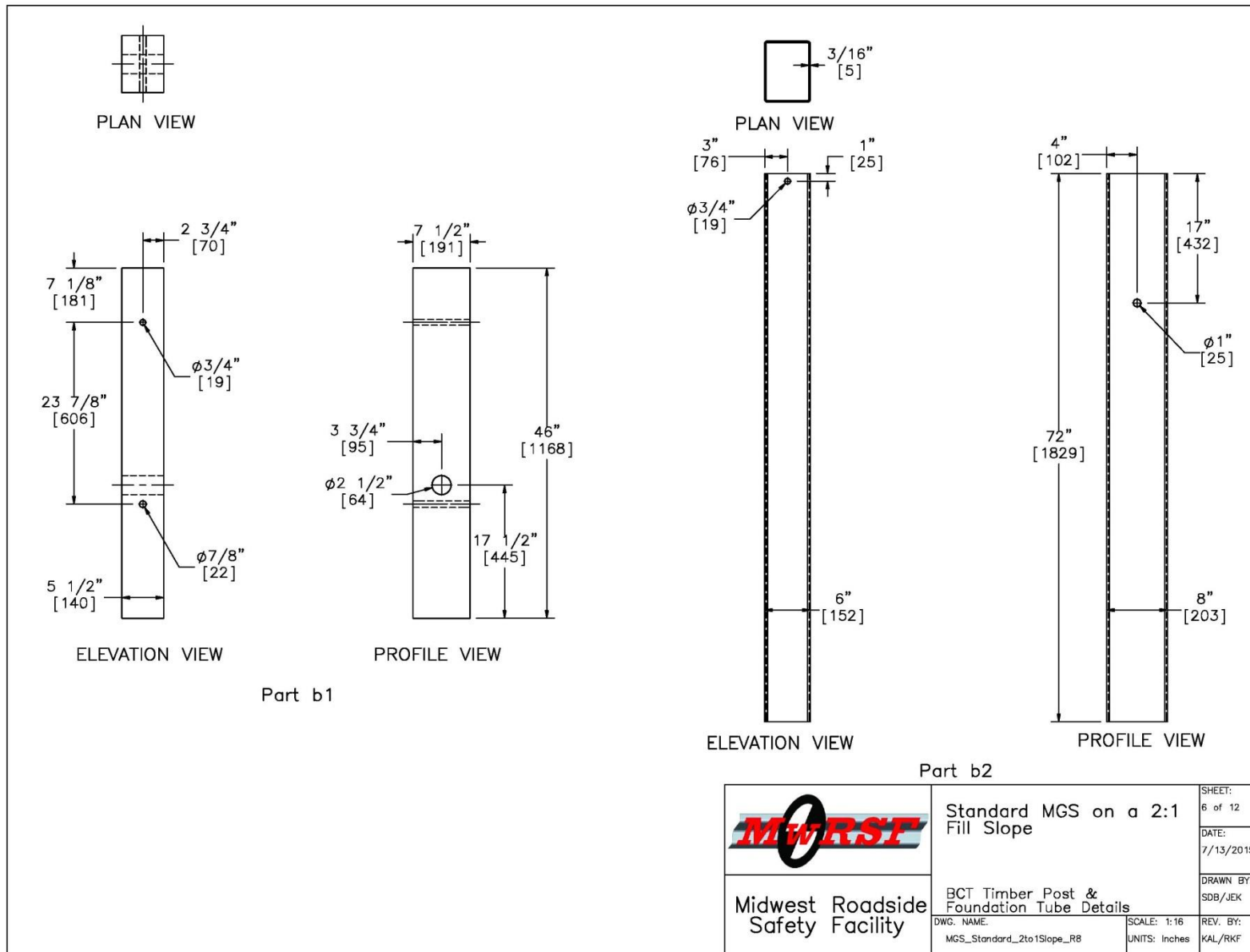

Figure 6. BCT Timber Post and Foundation Tube Details, Test No. MGSS-1

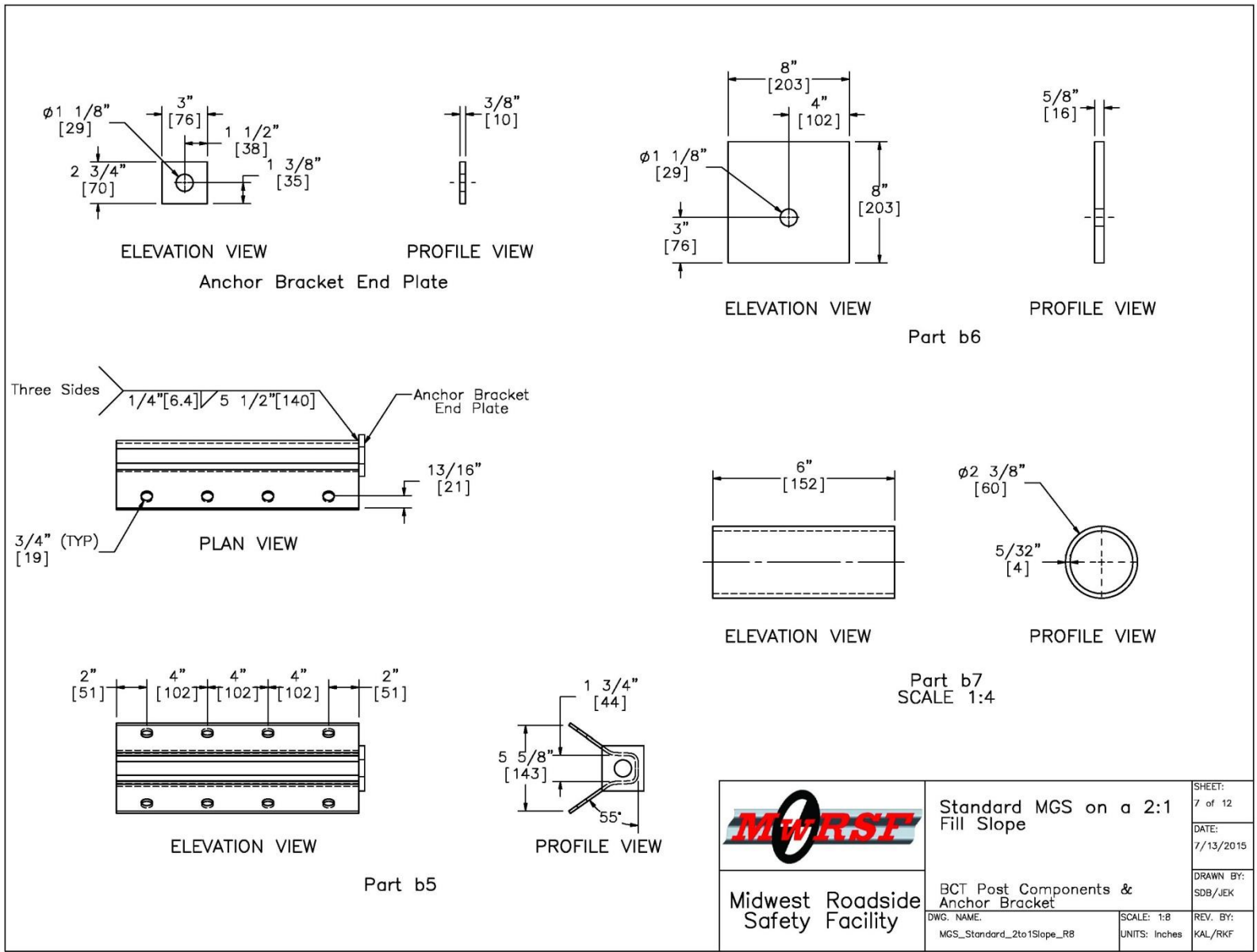



Figure 7. BCT Post Components and Anchor Bracket, Test No. MGSS-1

	Standard MGS on a 2:1 Fill Slope		SHEET: 7 of 12
			DATE: 7/13/2015
Midwest Roadside Safety Facility	BCT Post Components & Anchor Bracket		DRAWN BY: SDB/JEK
	DWG. NAME: MGS_Standard_2to1Slope_R8	SCALE: 1:8 UNITS: Inches	REV. BY: KAL/RKF

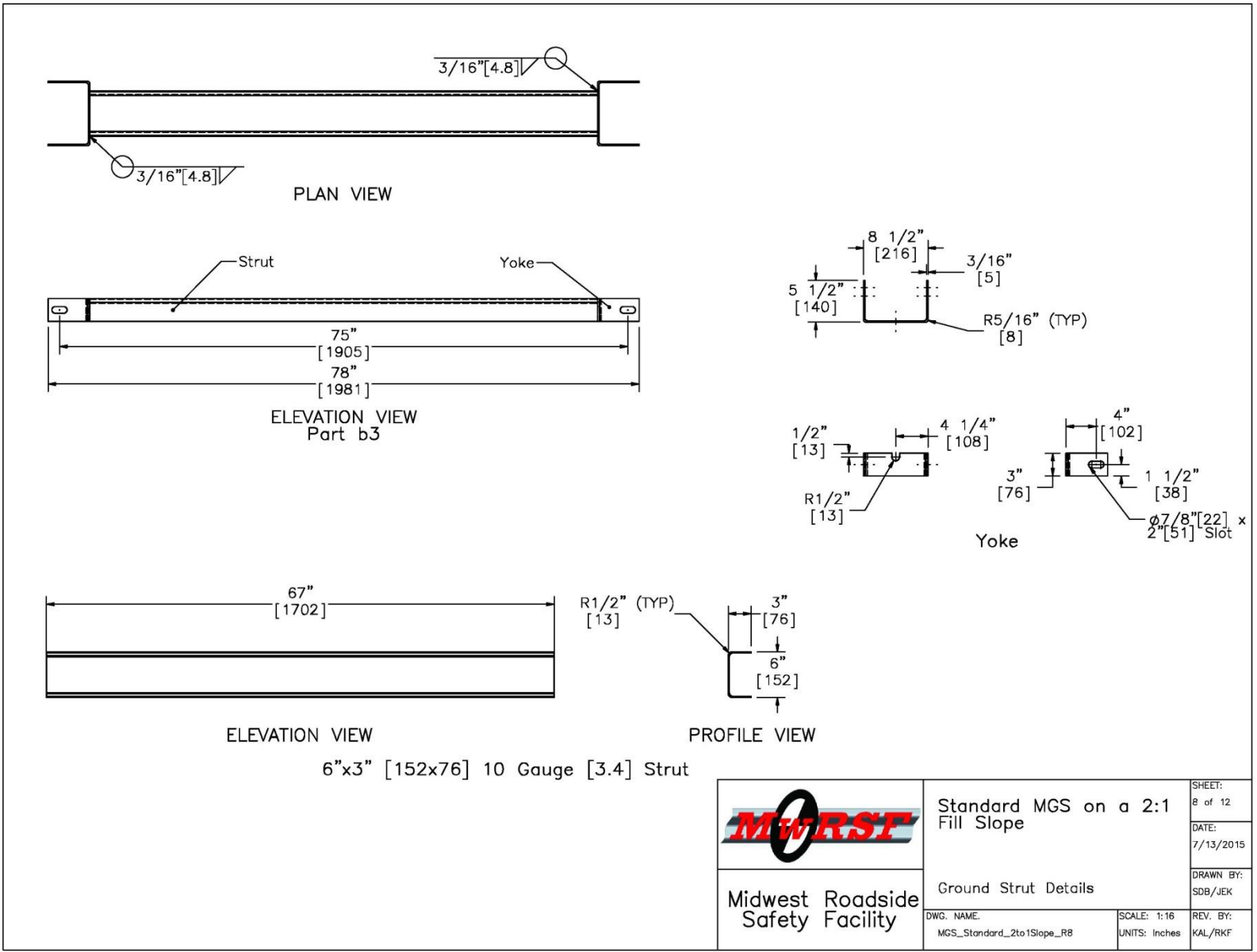

Figure 8. Ground Strut Details, Test No. MGSS-1

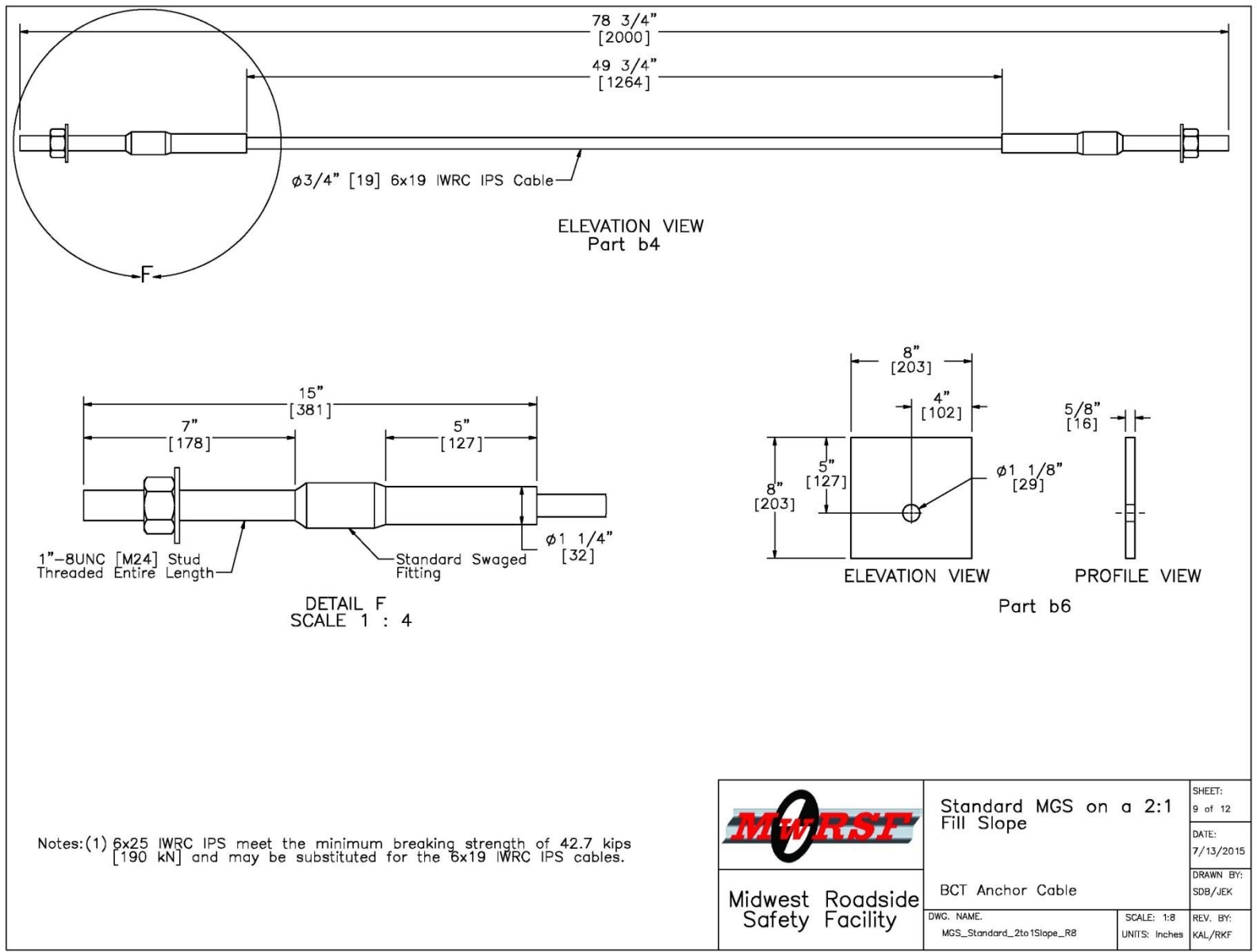

Figure 9. BCT Anchor Cable, Test No. MGSS-1

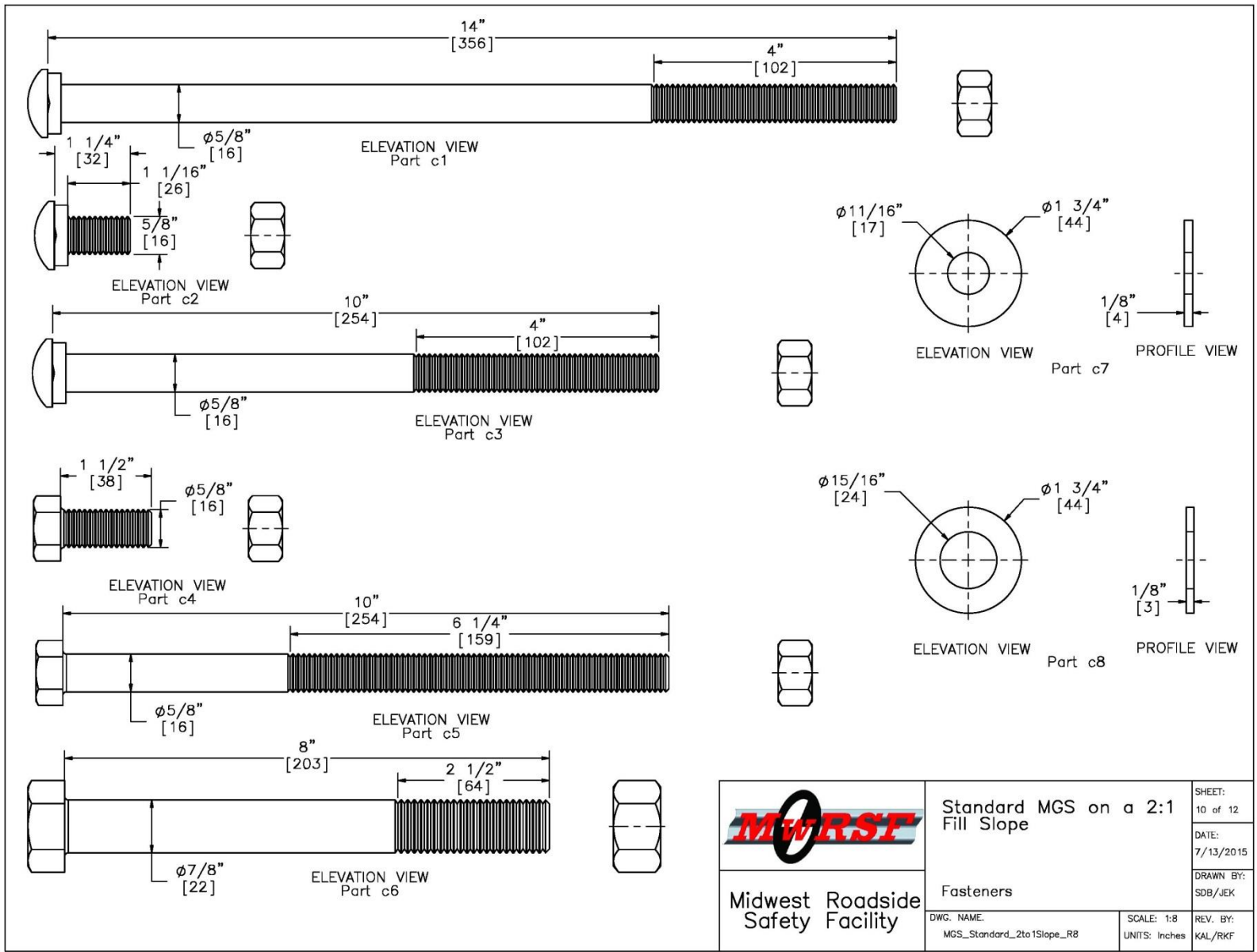



Figure 10. Fasteners, Test No. MGSS-1

 Midwest Roadside Safety Facility	Standard MGS on a 2:1 Fill Slope	SHEET: 10 of 12
	Fasteners	DATE: 7/13/2015
DWG. NAME: MGS_Standard_2to1Slope_R8	SCALE: 1:8 UNITS: Inches	DRAWN BY: SDB/JEK
		REV. BY: KAL/RKF

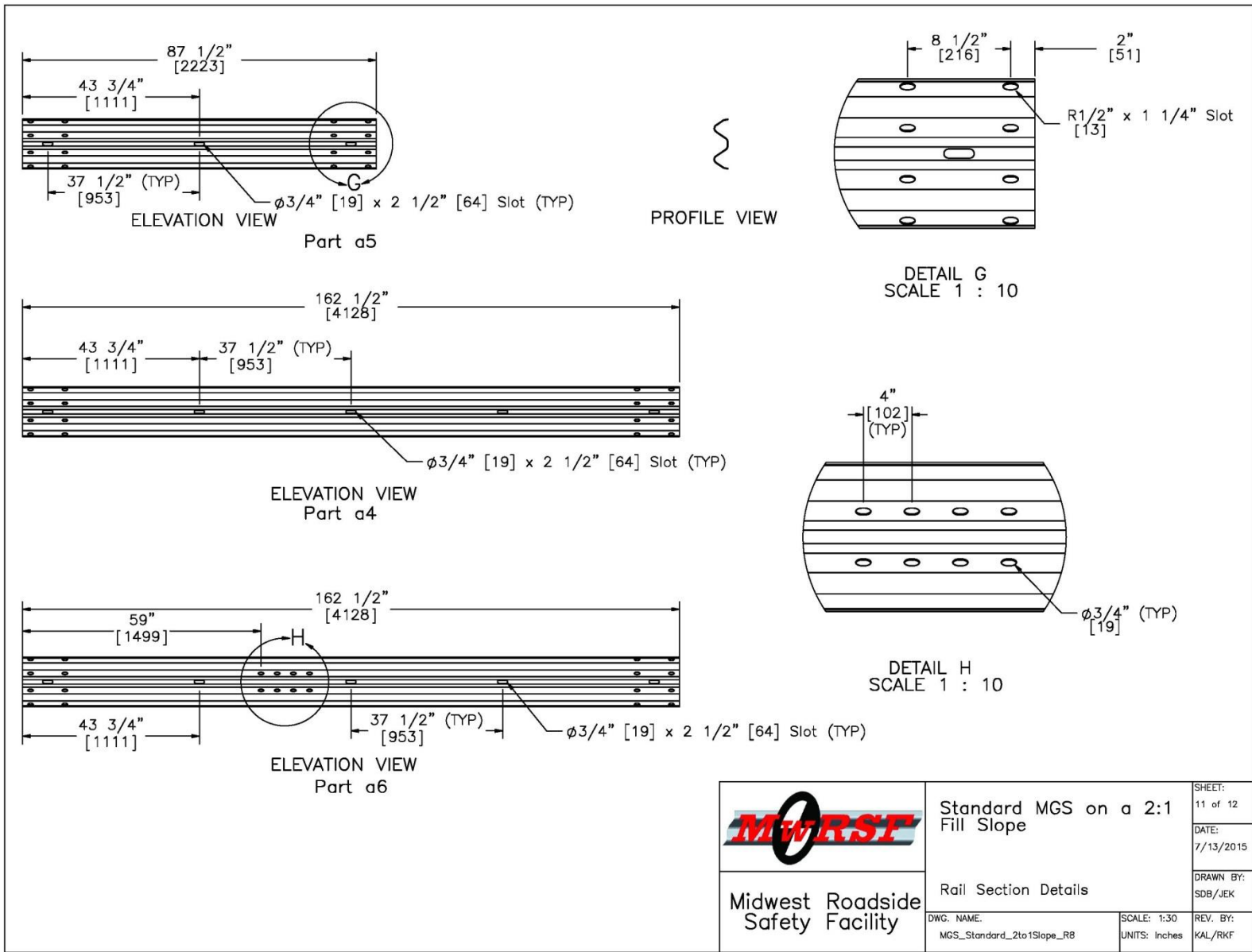

Figure 11. Rail Section Details, Test No. MGSS-1

Item No.	QTY.	Description	Material Specification	Hardware Guide Designation
a1	25	W6x8.5 [W152x12.6], 72" Long [1829] Steel Post	ASTM A992 Min. 50 ksi [345 MPa] Steel Galv. or W6x9 [W152x13.4] ASTM A36 Min. 36 ksi [248 MPa] Steel Galv.	PWE06
a2	25	6x12x14 1/4" [152x305x362] Timber Blockout for Steel Posts	SYP Grade No.1 or better	PDB10a-b
a3	25	16D Double Head Nail	-	-
a4	12	12'-6" [3810] W-Beam MGS Section	12 gauge [2.7] AASHTO M180 Galv.	RWM04a
a5	1	6'-3" [1905] W-Beam MGS Section	12 gauge [2.7] AASHTO M180 Galv.	RWM04a
a6	2	12'-6" [3810] W-Beam MGS End Section	12 gauge [2.7] AASHTO M180 Galv.	RWM14a
b1	4	BCT Timber Post - MGS Height	SYP Grade No. 1 or better (No knots, 18" [457] above or below ground tension face)	PDF01
b2	4	72" [1829] Long Foundation Tube	ASTM A500 Grade B Galv.	PTE06
b3	2	Strut and Yoke Assembly	ASTM A36 Steel Galv.	-
b4	4	BCT Cable Anchor Assembly	ø3/4" [19] 6x19 IWRC IPS Galvanized Wire Rope	FCA01
b5	2	Anchor Bracket Assembly	ASTM A36 Steel Galv.	FPA01
b6	2	8"x8"x5/8" [203x203x16] Anchor Bearing Plate	ASTM A36 Steel Galv.	FPB01
b7	2	2 3/8" [60] O.D. x 6" Long [152] BCT Post Sleeve	ASTM A53 Grade B Schedule 40 Galv.	FMM02
c1	25	5/8" [16] Dia. UNC, 14" [356] Long Guardrail Bolt and Nut	Bolt ASTM A307 Galv., Nut ASTM A563 A Galv.	FBB06
c2	112	5/8" [16] Dia. UNC, 1 1/4" [32] Guardrail Bolt and Nut	Bolt ASTM A307 Galv., Nut ASTM A563 A Galv.	FBB01
c3	4	5/8" [16] Dia. UNC, 10" [254] Long Guardrail Bolt and Nut	Bolt ASTM A307 Galv., Nut ASTM A563 A Galv.	FBB03
c4	16	5/8" [16] Dia. UNC, 1 1/2" [38] Long Hex Head Bolt and Nut	Bolt ASTM A307 Galv., Nut ASTM A563 A Galv.	FBX16a
c5	4	5/8" [16] Dia. UNC, 10" [254] Long Hex Head Bolt and Nut	Bolt ASTM A307 Galv., Nut ASTM A563 A Galv.	FBX16a
c6	4	7/8" [22] Dia. UNC, 8" [203] Long Hex Head Bolt and Nut	Bolt ASTM A307 Grade A Galv., Nut ASTM A563 A Galv.	-
c7	44	5/8" [16] Dia. Plain Round Washer	ASTM F844 Galv.	FWC14a
c8	8	7/8" [22] Dia. Plain Round Washer	ASTM F844 Galv.	-
 Midwest Roadside Safety Facility			Standard MGS on a 2:1 Fill Slope	SHEET: 12 of 12 DATE: 7/13/2015 DRAWN BY: SDB/JEK
			Bill of Materials	DWG. NAME: MGS_Standard_2to1Slope_RB SCALE: None UNITS: Inches REV. BY: KAL/RKF

Figure 12. Bill of Materials, Test No. MGSS-1



Figure 13. Test Installation Photographs, Test No. MGSS-1



Figure 14. Test Installation Photographs, Test No. MGSS-1

3 TEST REQUIREMENTS AND EVALUATION CRITERIA

3.1 Test Requirements

Longitudinal barriers, such as W-beam guardrails, must satisfy impact safety standards in order to be declared eligible for federal reimbursement by the Federal Highway Administration (FHWA) for use on the National Highway System (NHS). For new hardware, these safety standards consist of the guidelines and procedures published in MASH [6]. According to TL-3 of MASH, longitudinal barrier systems must be subjected to two full-scale vehicle crash tests, as summarized in Table 1.

W-beam barriers, specifically the MGS, struck by small cars have been shown to meet the MASH safety performance standards with little lateral deflection and with no significant potential for occupant risk problems. In test no. 2214MG-3, the standard MGS was successfully crash tested with a 2,588-lb (1,174-kg) small car impacting at a speed of 60.8 mph (97.8 km/h) and an angle of 25.4 degrees according to the safety performance criteria set forth in MASH [10-11]. In test no. MGSSYP-2, the standard MGS with Southern Yellow Pine (SYP) posts was also successfully impacted by a 2,612-lb (1,185-kg) small car at a speed of 61.5 mph (99.0 km/h) and at an angle of 25.3 degrees according to the MASH TL-3 safety performance criteria [12-13]. Further, the MGS was successfully crash tested according to the MASH TL-3 safety performance criteria with maximum rail heights of 34-in. (864-mm) and 36-in. (914-mm). In test no. MGSMRH-1, the MGS with a maximum rail height of 34-in. (864-mm), was impacted a 2,599-lb (1,174-kg) small car at 63.6 mph (102.4 km/h) and 25.0 degrees and in test no. MGSMRH-2, the MGS with a maximum height tolerance of 36-in. (914-mm), was impacted by a 2,583-lb (1,172-kg) small car at 64.1 mph (103.2 km/h) and 25.6 degrees [14]. These tests showed that a taller rail mounting height did not exhibit significant potential for occupant risk concerns for the small car. In test no. MGSNB-2, the non-blocked MGS was successfully

impacted by a 2,578-lb (1,169-kg) small car at 63.0 mph (101.4 km/h) and 25.5 degrees according to the MASH TL-3 safety performance criteria [15-16]. In test no. MGSGW-1, the non-blocked MGS was placed at the slope break point of a 3H:1V fill slope of a wire-faced MSE wall was successfully impacted by a 2,596-lb (1,178-kg) small car at a speed of 61.0 mph (98.2 km/h) and 25.3 degrees according to the MASH TL-3 safety performance criteria [17-18]. The two tests of the non-blocked MGS further show that even without blockouts the MGS performs satisfactorily when impacted by the MASH small car. Therefore, based on the success of prior small car testing on the MGS, the 2,425-lb (1,100-kg) passenger car crash test was deemed unnecessary for this project. Therefore, only test designation no. 3-11 with the 5,000-lb (2,268-kg) pickup truck was conducted for the system described herein.

Table 1. MASH TL-3 Crash Test Conditions

Test Article	Test Designation No.	Test Vehicle	Impact Conditions			Evaluation Criteria ¹
			Speed		Angle (deg)	
			mph	km/h		
Longitudinal Barrier	3-10	1100C	62	100	25	A,D,F,H,I
	3-11	2270P	62	100	25	A,D,F,H,I

¹ Evaluation criteria explained in Table 2.

3.2 Evaluation Criteria

Evaluation criteria for full-scale vehicle crash testing are based on three appraisal areas: (1) structural adequacy; (2) occupant risk; and (3) vehicle trajectory after collision. Criteria for structural adequacy are intended to evaluate the ability of the longitudinal barrier to contain and redirect impacting vehicles. In addition, controlled lateral deflection of the test article is acceptable. Occupant risk evaluates the degree of hazard to occupants in the impacting vehicle. Post-impact vehicle trajectory is a measure of the potential of the vehicle to result in a secondary

collision with other vehicles and/or fixed objects, thereby increasing the risk of injury to the occupants of the impacting vehicle and/or other vehicles. These evaluation criteria are summarized in Table 2 and defined in greater detail in MASH. The full-scale vehicle crash test was conducted and reported in accordance with the procedures provided in MASH.

In addition to the standard occupant risk measures, the Post-Impact Head Deceleration (PHD), the Theoretical Head Impact Velocity (THIV), and the Acceleration Severity Index (ASI) were determined and reported on the test summary sheet. Additional discussion on PHD, THIV and ASI is provided in MASH.

3.3 Soil Strength Requirements

In accordance with Chapter 3 and Appendix B of MASH, foundation soil strength must be verified before any full-scale crash testing can occur. During the installation of a soil-dependent system, additional W6x16 (W152x23.8) posts are to be installed near the impact region utilizing the same installation procedures as the system itself. Prior to full-scale testing, a dynamic impact test must be conducted to verify a minimum dynamic soil resistance of 7.5 kips (33.4 kN) at post deflections between 5 and 20 in. (127 and 508 mm) measured at a height of 25 in. (635 mm). If dynamic testing near the system is not desired, MASH permits a static test to be conducted instead and compared against the results of a previously established baseline test. In this situation, the soil must provide a resistance of at least 90% of the static baseline test at deflections of 5, 10, and 15 in. (127, 254, and 381 mm). Further details can be found in Appendix B of MASH.

Table 2. MASH Evaluation Criteria for Longitudinal Barrier

Structural Adequacy	A. Test article should contain and redirect the vehicle or bring the vehicle to a controlled stop; the vehicle should not penetrate, underride, or override the installation although controlled lateral deflection of the test article is acceptable.		
Occupant Risk	D. Detached elements, fragments or other debris from the test article should not penetrate or show potential for penetrating the occupant compartment, or present an undue hazard to other traffic, pedestrians, or personnel in a work zone. Deformations of, or intrusions into, the occupant compartment should not exceed limits set forth in Section 5.3 and Appendix E of MASH.		
	F. The vehicle should remain upright during and after collision. The maximum roll and pitch angles are not to exceed 75 degrees.		
	H. Occupant Impact Velocity (OIV) (see Appendix A, Section A5.3 of MASH for calculation procedure) should satisfy the following limits:		
	Occupant Impact Velocity Limits		
	Component	Preferred	Maximum
	Longitudinal and Lateral	30 ft/s (9.1 m/s)	40 ft/s (12.2 m/s)
I. The Occupant Ridedown Acceleration (ORA) (see Appendix A, Section A5.3 of MASH for calculation procedure) should satisfy the following limits:	Occupant Ridedown Acceleration Limits		
Component	Preferred	Maximum	
Longitudinal and Lateral	15.0 g's	20.49 g's	

4 TEST CONDITIONS

4.1 Test Facility

The testing facility is located at the Lincoln Air Park on the northwest side of the Lincoln Municipal Airport and is approximately 5 miles (8.0 km) northwest of the University of Nebraska-Lincoln city campus.

4.2 Vehicle Tow and Guidance System

A reverse cable tow system with a 1:2 mechanical advantage was used to propel the test vehicle. The distance traveled and the speed of the tow vehicle were one-half those of the test vehicle. The test vehicle was released from the tow cable before impact with the barrier system. A digital speedometer on the tow vehicle increased the accuracy of the test vehicle impact speed.

A vehicle guidance system developed by Hinch [19] was used to steer the test vehicle. A guide flag, attached to the right-front wheel and the guide cable, was sheared off before impact with the barrier system. The $\frac{3}{8}$ -in. (9.5-mm) diameter guide cable was tensioned to approximately 3,500 lb (15.6 kN) and supported both laterally and vertically every 100 ft (30.5 m) by hinged stanchions. The hinged stanchions stood upright while holding up the guide cable, but as the vehicle was towed down the line, the guide flag struck and knocked each stanchion to the ground.

4.3 Test Vehicles

For test no. MGSS-1, a 2007 Dodge Ram 1500 pickup truck was used as the test vehicle. The curb, test inertial, and gross static vehicle weights were 5,024 lb (2,279 kg), 4,992 lb (2,264 kg), and 5,158 lb (2,340 kg), respectively. The test vehicle is shown in Figure 15, and vehicle dimensions are shown in Figure 16.



Figure 15. Test Vehicle, Test No. MGSS-1

Date: <u>8/14/2014</u>		Test Number: <u>MGSS-1</u>		Model: <u>Ram1500</u>																																																																																	
Make: <u>Dodge</u>		Vehicle I.D.#: <u>1D7HA18K37J598039</u>																																																																																			
Tire Size: <u>265/70 R17</u>		Year: <u>2007</u>		Odometer: <u>150188</u>																																																																																	
Tire Inflation Pressure: <u>35psi</u>																																																																																					
*(All Measurements Refer to Impacting Side)																																																																																					
			Vehicle Geometry -- in. (mm)																																																																																		
			<table border="0" style="width:100%;"> <tr> <td>a</td><td><u>77 3/4 (1975)</u></td> <td>b</td><td><u>74 7/8 (1902)</u></td> </tr> <tr> <td>c</td><td><u>228 1/4 (5798)</u></td> <td>d</td><td><u>47 1/2 (1207)</u></td> </tr> <tr> <td>e</td><td><u>140 1/2 (3569)</u></td> <td>f</td><td><u>40 1/4 (1022)</u></td> </tr> <tr> <td>g</td><td><u>28 (711)</u></td> <td>h</td><td><u>64 1/2 (1638)</u></td> </tr> <tr> <td>i</td><td><u>16 (406)</u></td> <td>j</td><td><u>29 (737)</u></td> </tr> <tr> <td>k</td><td><u>20 1/4 (514)</u></td> <td>l</td><td><u>28 1/2 (724)</u></td> </tr> <tr> <td>m</td><td><u>67 1/2 (1715)</u></td> <td>n</td><td><u>67 3/4 (1721)</u></td> </tr> <tr> <td>o</td><td><u>44 1/4 (1124)</u></td> <td>p</td><td><u>3 1/2 (89)</u></td> </tr> <tr> <td>q</td><td><u>32 (813)</u></td> <td>r</td><td><u>18 1/2 (470)</u></td> </tr> <tr> <td>s</td><td><u>15 1/4 (387)</u></td> <td>t</td><td><u>75 1/4 (1911)</u></td> </tr> <tr> <td colspan="2">Wheel Center Height Front</td> <td colspan="2"><u>14 7/8 (378)</u></td> </tr> <tr> <td colspan="2">Wheel Center Height Rear</td> <td colspan="2"><u>15 1/8 (384)</u></td> </tr> <tr> <td colspan="2">Wheel Well Clearance (F)</td> <td colspan="2"><u>35 3/4 (908)</u></td> </tr> <tr> <td colspan="2">Wheel Well Clearance (R)</td> <td colspan="2"><u>38 (965)</u></td> </tr> <tr> <td colspan="2">Frame Height (F)</td> <td colspan="2"><u>18 3/4 (476)</u></td> </tr> <tr> <td colspan="2">Frame Height (R)</td> <td colspan="2"><u>24 7/8 (632)</u></td> </tr> <tr> <td colspan="2">Engine Type</td> <td colspan="2"><u>Gas V-6</u></td> </tr> <tr> <td colspan="2">Engine Size</td> <td colspan="2"><u>3.7L</u></td> </tr> <tr> <td colspan="2">Transmission Type:</td> <td colspan="2"> <input type="checkbox"/> Automatic <input checked="" type="checkbox"/> Manual </td> </tr> <tr> <td colspan="2"></td> <td colspan="2"> <input type="checkbox"/> FWD <input checked="" type="checkbox"/> RWD <input type="checkbox"/> 4WD </td> </tr> </table>			a	<u>77 3/4 (1975)</u>	b	<u>74 7/8 (1902)</u>	c	<u>228 1/4 (5798)</u>	d	<u>47 1/2 (1207)</u>	e	<u>140 1/2 (3569)</u>	f	<u>40 1/4 (1022)</u>	g	<u>28 (711)</u>	h	<u>64 1/2 (1638)</u>	i	<u>16 (406)</u>	j	<u>29 (737)</u>	k	<u>20 1/4 (514)</u>	l	<u>28 1/2 (724)</u>	m	<u>67 1/2 (1715)</u>	n	<u>67 3/4 (1721)</u>	o	<u>44 1/4 (1124)</u>	p	<u>3 1/2 (89)</u>	q	<u>32 (813)</u>	r	<u>18 1/2 (470)</u>	s	<u>15 1/4 (387)</u>	t	<u>75 1/4 (1911)</u>	Wheel Center Height Front		<u>14 7/8 (378)</u>		Wheel Center Height Rear		<u>15 1/8 (384)</u>		Wheel Well Clearance (F)		<u>35 3/4 (908)</u>		Wheel Well Clearance (R)		<u>38 (965)</u>		Frame Height (F)		<u>18 3/4 (476)</u>		Frame Height (R)		<u>24 7/8 (632)</u>		Engine Type		<u>Gas V-6</u>		Engine Size		<u>3.7L</u>		Transmission Type:		<input type="checkbox"/> Automatic <input checked="" type="checkbox"/> Manual				<input type="checkbox"/> FWD <input checked="" type="checkbox"/> RWD <input type="checkbox"/> 4WD	
a	<u>77 3/4 (1975)</u>	b	<u>74 7/8 (1902)</u>																																																																																		
c	<u>228 1/4 (5798)</u>	d	<u>47 1/2 (1207)</u>																																																																																		
e	<u>140 1/2 (3569)</u>	f	<u>40 1/4 (1022)</u>																																																																																		
g	<u>28 (711)</u>	h	<u>64 1/2 (1638)</u>																																																																																		
i	<u>16 (406)</u>	j	<u>29 (737)</u>																																																																																		
k	<u>20 1/4 (514)</u>	l	<u>28 1/2 (724)</u>																																																																																		
m	<u>67 1/2 (1715)</u>	n	<u>67 3/4 (1721)</u>																																																																																		
o	<u>44 1/4 (1124)</u>	p	<u>3 1/2 (89)</u>																																																																																		
q	<u>32 (813)</u>	r	<u>18 1/2 (470)</u>																																																																																		
s	<u>15 1/4 (387)</u>	t	<u>75 1/4 (1911)</u>																																																																																		
Wheel Center Height Front		<u>14 7/8 (378)</u>																																																																																			
Wheel Center Height Rear		<u>15 1/8 (384)</u>																																																																																			
Wheel Well Clearance (F)		<u>35 3/4 (908)</u>																																																																																			
Wheel Well Clearance (R)		<u>38 (965)</u>																																																																																			
Frame Height (F)		<u>18 3/4 (476)</u>																																																																																			
Frame Height (R)		<u>24 7/8 (632)</u>																																																																																			
Engine Type		<u>Gas V-6</u>																																																																																			
Engine Size		<u>3.7L</u>																																																																																			
Transmission Type:		<input type="checkbox"/> Automatic <input checked="" type="checkbox"/> Manual																																																																																			
		<input type="checkbox"/> FWD <input checked="" type="checkbox"/> RWD <input type="checkbox"/> 4WD																																																																																			
<table border="0" style="width:100%;"> <tr> <td colspan="4">Mass Distribution lb (kg)</td> </tr> <tr> <td>Gross Static</td> <td>LF</td> <td><u>1467 (665)</u></td> <td>RF</td> <td><u>1334 (605)</u></td> </tr> <tr> <td></td> <td>LR</td> <td><u>1157 (525)</u></td> <td>RR</td> <td><u>1200 (544)</u></td> </tr> <tr> <td colspan="2">Weights lb (kg)</td> <td>Curb</td> <td>Test Inertial</td> <td>Gross Static</td> </tr> <tr> <td>W-front</td> <td></td> <td><u>2759 (1251)</u></td> <td><u>2701 (1225)</u></td> <td><u>2801 (1271)</u></td> </tr> <tr> <td>W-rear</td> <td></td> <td><u>2265 (1027)</u></td> <td><u>2291 (1039)</u></td> <td><u>2357 (1069)</u></td> </tr> <tr> <td>W-total</td> <td></td> <td><u>5024 (2279)</u></td> <td><u>4992 (2264)</u></td> <td><u>5158 (2340)</u></td> </tr> </table>						Mass Distribution lb (kg)				Gross Static	LF	<u>1467 (665)</u>	RF	<u>1334 (605)</u>		LR	<u>1157 (525)</u>	RR	<u>1200 (544)</u>	Weights lb (kg)		Curb	Test Inertial	Gross Static	W-front		<u>2759 (1251)</u>	<u>2701 (1225)</u>	<u>2801 (1271)</u>	W-rear		<u>2265 (1027)</u>	<u>2291 (1039)</u>	<u>2357 (1069)</u>	W-total		<u>5024 (2279)</u>	<u>4992 (2264)</u>	<u>5158 (2340)</u>																																														
Mass Distribution lb (kg)																																																																																					
Gross Static	LF	<u>1467 (665)</u>	RF	<u>1334 (605)</u>																																																																																	
	LR	<u>1157 (525)</u>	RR	<u>1200 (544)</u>																																																																																	
Weights lb (kg)		Curb	Test Inertial	Gross Static																																																																																	
W-front		<u>2759 (1251)</u>	<u>2701 (1225)</u>	<u>2801 (1271)</u>																																																																																	
W-rear		<u>2265 (1027)</u>	<u>2291 (1039)</u>	<u>2357 (1069)</u>																																																																																	
W-total		<u>5024 (2279)</u>	<u>4992 (2264)</u>	<u>5158 (2340)</u>																																																																																	
<table border="0" style="width:100%;"> <tr> <td colspan="2">GVWR Ratings</td> </tr> <tr> <td>Front</td> <td><u>3700</u></td> </tr> <tr> <td>Rear</td> <td><u>3900</u></td> </tr> <tr> <td>Total</td> <td><u>6700</u></td> </tr> </table>			GVWR Ratings		Front	<u>3700</u>	Rear	<u>3900</u>	Total	<u>6700</u>	<table border="0" style="width:100%;"> <tr> <td colspan="2">Dummy Data</td> </tr> <tr> <td>Type:</td> <td><u>Hybrid II</u></td> </tr> <tr> <td>Mass:</td> <td><u>166 lb</u></td> </tr> <tr> <td>Seat Position:</td> <td><u>Driver</u></td> </tr> </table>			Dummy Data		Type:	<u>Hybrid II</u>	Mass:	<u>166 lb</u>	Seat Position:	<u>Driver</u>																																																																
GVWR Ratings																																																																																					
Front	<u>3700</u>																																																																																				
Rear	<u>3900</u>																																																																																				
Total	<u>6700</u>																																																																																				
Dummy Data																																																																																					
Type:	<u>Hybrid II</u>																																																																																				
Mass:	<u>166 lb</u>																																																																																				
Seat Position:	<u>Driver</u>																																																																																				
Note any damage prior to test: <u>Dent in Driver's side fender behind wheel.</u>																																																																																					

Figure 16. Vehicle Dimensions, Test No. MGSS-1

The longitudinal component of the center of gravity (c.g.) was determined using the measured axle weights. The Suspension Method [20] was used to determine the vertical component of the c.g. for the pickup truck. This method is based on the principle that the c.g. of any freely suspended body is in the vertical plane through the point of suspension. The vehicle was suspended successively in three positions, and the respective planes containing the c.g. were established. The intersection of these planes pinpointed the final c.g. location for the test inertial condition. The location of the final c.g. is shown in Figures 16 and 17. Data used to calculate the location of the c.g. and ballast information are shown in Appendix B.

Square, black- and white-checked targets were placed on the vehicle for reference to be viewed from the high-speed digital video cameras and aid in the video analysis, as shown in Figure 17. Round, checkered targets were placed on the center of gravity on the left-side door, the right-side door, and the roof of the vehicle.

The front wheels of the test vehicle were aligned to vehicle standards except the toe-in value was adjusted to zero so that the vehicles would track properly along the guide cable. A 5B flash bulb was mounted on the left side of the vehicle's dash and was fired by a pressure tape switch mounted at the impact corner of the bumper. The flash bulb was fired upon initial impact with the test article to create a visual indicator of the precise time of impact on the high-speed videos. A remote-controlled brake system was installed in the test vehicle so the vehicle could be brought safely to a stop after the test.

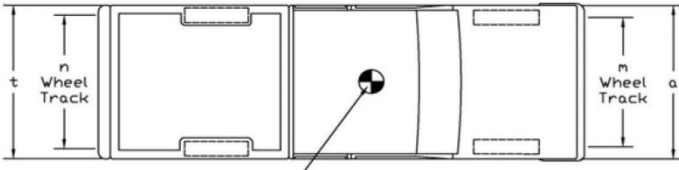
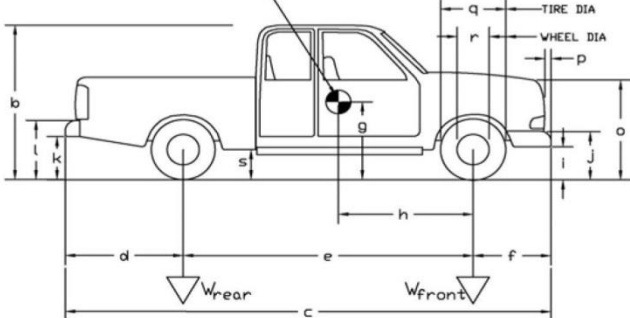
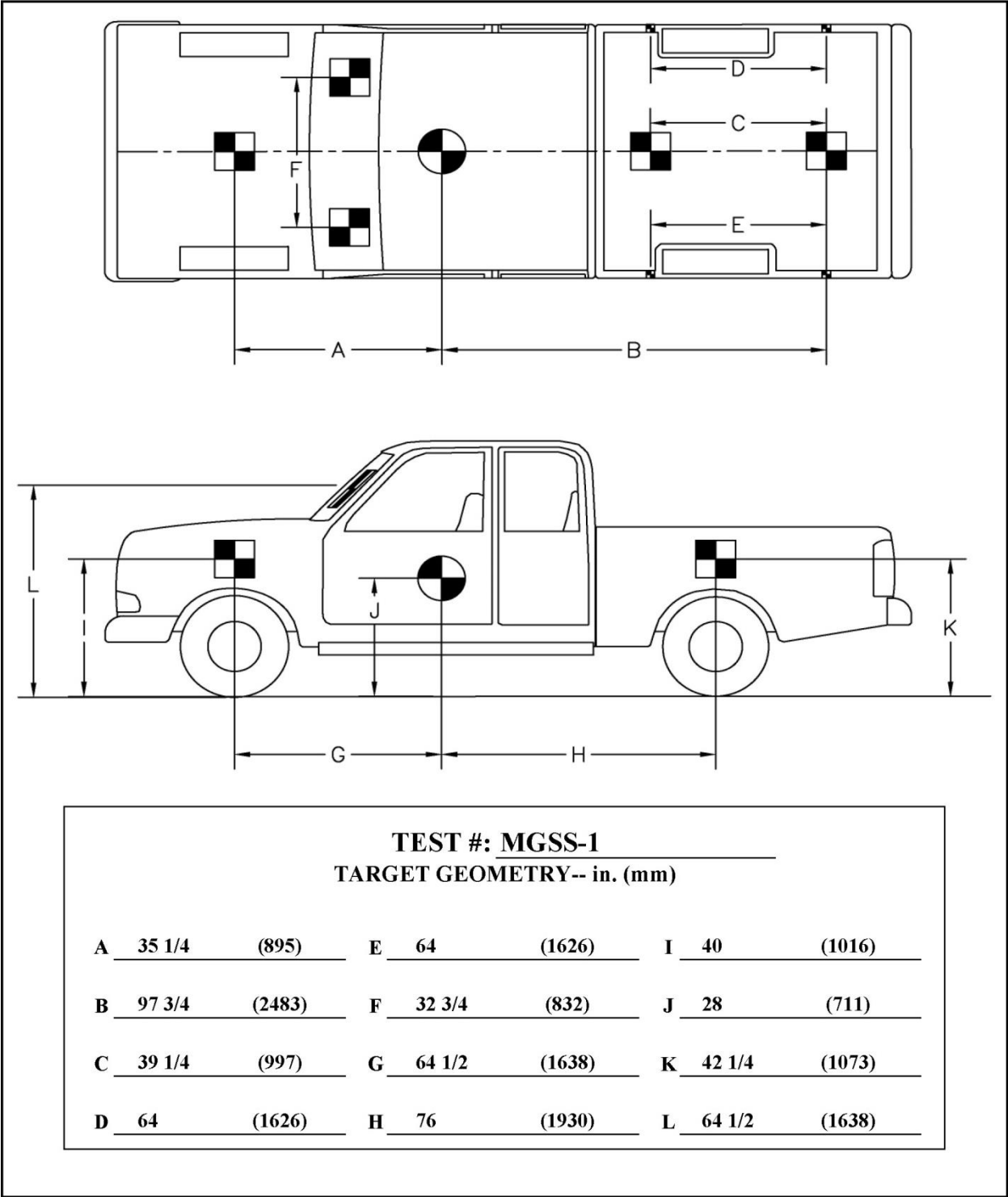

Figure 17. Target Geometry, Test No. MGSS-1

4.4 Simulated Occupant

For test no MGSS-1, A Hybrid II 50th-Percentile, Adult Male Dummy, equipped with clothing and footwear, was placed in the left-front seat of the test vehicle with the seat belt fastened. The dummy, which had a final weight of 166 lb (75 kg), was model no. 572, serial no. 451, and was manufactured by Android Systems of Carson, California. As recommended by MASH, the dummy was not included in calculating the c.g location.

4.5 Data Acquisition Systems

4.5.1 Accelerometers

Two environmental shock and vibration sensor/recorder systems were used to measure the accelerations in the longitudinal, lateral, and vertical directions. All of the accelerometers were mounted near the center of gravity of the test vehicle. The electronic accelerometer data obtained in dynamic testing was filtered using the SAE Class 60 and the SAE Class 180 Butterworth filters conforming to SAE J211/1 specifications [21].

The two systems, the SLICE-1 and SLICE-2 units, were modular data acquisition systems manufactured by Diversified Technical Systems (DTS) of Seal Beach, California. The acceleration sensors were mounted inside the bodies of custom-built SLICE 6DX event data recorders and recorded data at 10,000 Hz to the onboard microprocessor. Each SLICE 6DX was configured with 7 GB of non-volatile flash memory, a range of ± 500 g's, a sample rate of 10,000 Hz, and a 1,650 Hz (CFC 1000) anti-aliasing filter. The "SLICEWare" computer software program and a customized Microsoft Excel worksheet were used to analyze and plot the accelerometer data.

4.5.2 Rate Transducers

Two identical angle rate sensor systems mounted inside the bodies of the SLICE-1 and SLICE-2 event data recorders were used to measure the rates of rotation of the test vehicle. Each

SLICE MICRO Triax ARS had a range of 1,500 degrees/sec in each of the three directions (roll, pitch, and yaw) and recorded data at 10,000 Hz to the onboard microprocessors. The raw data measurements were then downloaded, converted to the proper Euler angles for analysis, and plotted. The “SLICEWare” computer software program and a customized Microsoft Excel worksheet were used to analyze and plot the angular rate sensor data.

4.5.3 Retroreflective Optic Speed Trap

The retroreflective optic speed trap was used to determine the speed of the bogie vehicle before impact. Five retroreflective targets, spaced at approximately 18-in. (457-mm) intervals, were applied to the side of the vehicle. When the emitted beam of light was reflected by the targets and returned to the Emitter/Receiver, a signal was sent to the data acquisition computer, recording at 10,000 Hz, as well as the external LED box activating the LED flashes. The speed was then calculated using the spacing between the retroreflective targets and the time between the signals. LED lights and high-speed digital video analysis are only used as a backup in the event that vehicle speeds cannot be determined from the electronic data.

4.5.4 Load Cells

Load cells, shown in Figure 18, were installed in the upstream anchor cable for test no. MGSS-1. The load cells were Transducer Techniques model nos. PCB 1-1376 and 261278 with a load range up to 80 kips (356 kN). During testing, output voltage signals were sent from the transducers to a National Instruments PCI-6071E data acquisition board, acquired with LabView software, and stored on a personal computer at a sample rate of 10,000 Hz.

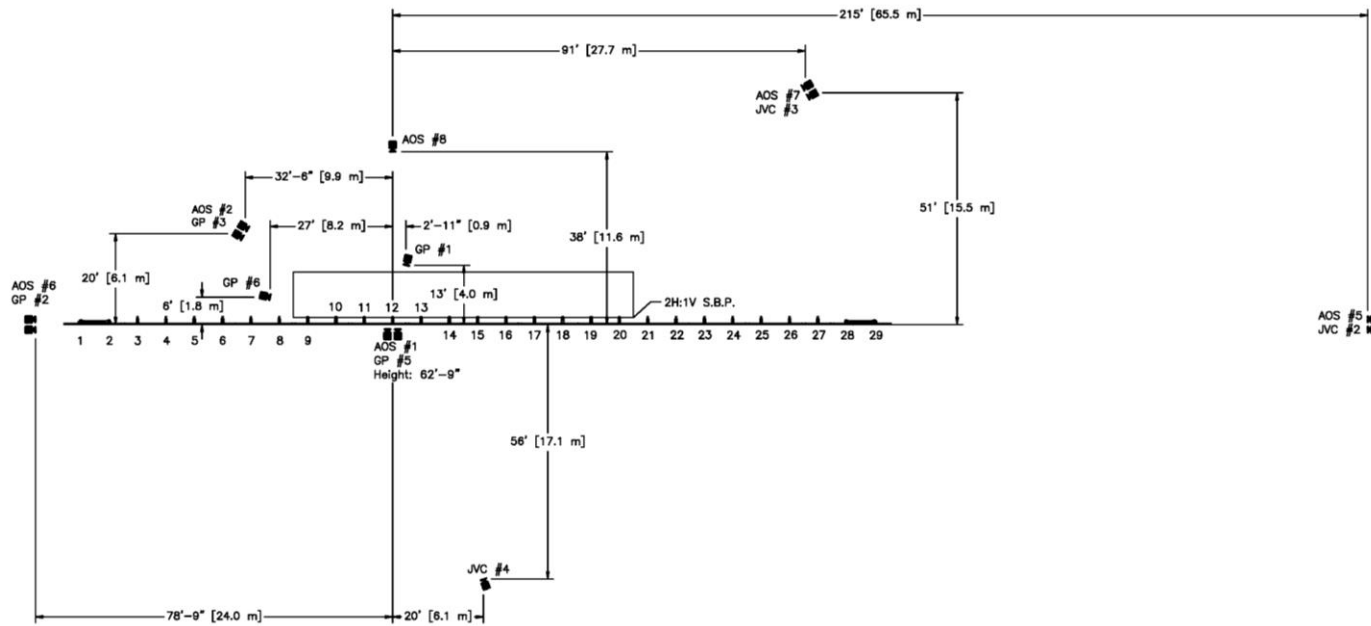

Figure 18. Load Cell Placement, Test No. MGSS-1

4.5.5 Digital Photography

Six AOS high-speed digital video cameras, six GoPro digital video cameras, and three JVC digital video cameras were utilized to film test no. MGSS-1. One of the GoPro cameras was on-board the test vehicle. Camera details, camera operating speeds, lens information, and a schematic of the other camera locations relative to the system are shown in Figure 19.

The high-speed videos were analyzed using ImageExpress MotionPlus and RedLake MotionScope software programs. Actual camera speed and camera divergence factors were considered in the analysis of the high-speed videos. A Nikon D50 digital still camera was used to document pre-test and post-test conditions for the test. One of the GoPro cameras was onboard the vehicle during the test.



No.	Type	Operating Speed (frames/sec)	Lens	Lens Setting
AOS-1	Vitcam CTM	500	Cosmicar 12.5 mm Fixed	
AOS-2	AOS Vitcam	500	Nikor 20 mm Fixed	
AOS-5	AOS X-PRI	500	Canon TV 200 mm 17-102	102
AOS-6	AOS X-PRI	500	Fujinon 50 mm Fixed	
AOS-7	AOS X-PRI	500	Sigma 24-135	½ btwn 35-50
AOS-8	AOS S-VIT 1531	500	Sigma 28-70	28
GP-1	GoPro Hero 3	120		
GP-2	GoPro Hero 3	120		
GP-3	GoPro Hero 3	120		
GP-4	GoPro Hero 3	120		
GP-5	GoPro Hero 3	120		
GP-6	GoPro Hero 3	120		
JVC-2	JVC – GZ-MG27u (Everio)	29.97		
JVC-3	JVC – GZ-MG27u (Everio)	29.97		
JVC-4	JVC – GZ-MG27u (Everio)	29.97		

Figure 19. Camera Locations, Speeds, and Lens Settings, Test No. MGSS-1

5 FULL-SCALE CRASH TEST NO. MGSS-1

5.1 Static Soil Test

Before full-scale crash test no. MGSS-1 was conducted, the strength of the foundation soil was evaluated with a static test, as described in MASH. The static test results, as shown in Appendix C, demonstrated a soil resistance above the baseline test limits. Thus, the soil provided adequate strength, and full-scale crash testing could be conducted on the barrier system.

5.2 Weather Conditions

Test no. MGSS-1 was conducted on August 14, 2014 at approximately 1:30 p.m. The weather conditions, as per the National Oceanic and Atmospheric Administration (station 14939/LNK), were reported as shown in Table 3.

Table 3. Weather Conditions, Test No. MGSS-1

Temperature	88°F
Humidity	40%
Wind Speed	13 mph
Wind Direction	120° from True North
Sky Conditions	Sunny
Visibility	10 Statute Miles
Pavement Surface	Dry
Previous 3-Day Precipitation	0 in.
Previous 7-Day Precipitation	0 in.

5.3 Test No. MGSS-1

The 5,158-lb (2,340-kg) pickup truck impacted the standard MGS placed at the slope break point of a 1V:2H fill slope at a speed of 61.6 mph (99.1 km/h) and an angle of 26.3 degrees. A summary of the test results and sequential photographs are shown in Figure 19. Additional sequential photographs are shown in Figures 20 and 21. Documentary photographs of the crash test are shown in Figure 23.

5.4 Test Description

Initial vehicle impact was to occur 18 ft – 9 in. (5.7 m) upstream from the centerline of post no. 15, as shown in Figure 24, which was selected using the CIP plots found in Section 2.3 of MASH. The actual point of impact was 18 ft – 6 in. (5.6 m) upstream from the centerline of post no. 15. A sequential description of the impact events is contained in

Table 4. The vehicle came to rest 164 ft (50.0 m) downstream from the point of impact and 50 ft – 4 in. (15.3 m) behind the front of the rail. The vehicle trajectory and final position are shown in Figures 20 and 25.

Table 4. Sequential Description of Impact Events, Test No. MGSS-1

TIME (sec)	EVENT
0.000	Vehicle left-front bumper contacted the rail between post nos. 12 and 13.
0.006	Post no. 12 deflected backward.
0.010	Post no. 13 deflected backward.
0.014	Vehicle left headlight deformed.
0.020	Post no. 11 deflected backward.
0.022	Post no. 14 deflected backward.
0.024	Vehicle began to yaw away from barrier.
0.030	Post no. 10 deflected backward, and vehicle's hood and grill deformed.
0.032	Vehicle left-front door deformed.
0.046	Post no. 11 rotated backward, and vehicle's left-front tire entered slope.
0.058	Post no. 15 deflected backward.
0.062	Post no. 9 deflected backward.
0.072	Post nos. 8 and 16 deflected backward.
0.082	Vehicle pitched upward.
0.122	Vehicle began to roll toward barrier.
0.128	Post no. 14 disengaged from guardrail, and vehicle's left-front door contacted guardrail between post nos. 13 and 14.
0.136	Post no. 17 deflected backward.
0.138	Post no. 19 deflected backward.

0.140	Post no. 18 deflected backward.
0.170	Vehicle left-rear wheel entered slope.
0.190	Post no. 15 disengaged from guardrail.
0.192	Post no. 20 deflected backward.
0.238	Vehicle left quarter panel contacted guardrail between post nos. 12 and 13.
0.274	Post nos. 13 and 16 disengaged from guardrail.
0.280	Vehicle left headlight detached, and vehicle left taillight deformed.
0.402	Post no. 17 disengaged from guardrail.
0.406	Vehicle began to roll away from barrier.
0.432	Vehicle began to yaw toward barrier and pitched downward.
0.534	Post no. 18 disengaged from guardrail.
0.618	Vehicle was parallel to system at a speed of 43.5 mph (70 km/hr).
0.650	Vehicle began to yaw away from barrier.
0.742	Vehicle pitched upward.
0.748	Vehicle began to roll toward barrier.
0.966	Vehicle lost contact with system at a speed of 40.5 mph (65.1 km/hr) and an angle of 16 degrees.
0.986	Vehicle pitched downward.
1.176	Vehicle pitched upward.
1.590	Vehicle pitched downward.

5.5 Barrier Damage

Damage to the barrier was moderate, as shown in Figures 27 through 31. Barrier damage consisted of deformed W-beam rail, disengaged W-beam rail from the posts, and post rotation out of the soil. The length of vehicle contact along the barrier was approximately 49 ft – 6 in. (15.1 m), which spanned from 8¼ in. (210 mm) downstream from the centerline of post no. 12 through 2½ in. (64 mm) downstream from the centerline of post no. 20.

The W-beam rail deformed between post nos. 12 through 21. Contact marks were found on the guardrail between post nos. 12 and 21. An 8-in. (203-mm) tear occurred vertically from the end anchorage rail bolt hole at post no. 1. Post no. 2 split vertically through the bolt hole.

Flattening occurred on the bottom corrugation of the rail from post nos. 13 through 16. Partial bolt pullout occurred at post nos. 9 through 12, 19, 20, and 25. The bolt pulled through the rail at post nos. 1, 3 through 8, 13 through 15, 19, and 22 through 24. Post no. 2 split, while post no. 3 twisted downstream. Post nos. 9 through 12 and 17 through 20 rotated backwards and twisted downstream, while post no. 13 twisted upstream. Post nos. 14 through 16 rotated out of the soil. Post nos. 21 through 29 remained unchanged.

The maximum lateral permanent set rail and post deflections were 56 in. (1,422 mm) at post no. 17 and 52 ¾ in. (1,340 mm) at post no. 17, as measured in the field. Post nos. 14 through 16 were removed from the system and were not considered for deflections. The maximum lateral dynamic rail and barrier deflections was 72.9 in. (1,852 mm) at the midspan of post nos. 14 and 15, and 69.9 in. (1775 mm) at post no. 14, as determined from high-speed digital video analysis. The working width of the system was found to be 77.4 in. (1,966 mm), also determined from high-speed digital video analysis.

5.6 Vehicle Damage

The damage to the vehicle was minor, as shown in Figure 32. The maximum occupant compartment deformations are listed in Table 5 along with the deformation limits established in MASH for various areas of the occupant compartment. Note that none of the MASH established deformation limits were violated. Complete occupant compartment and vehicle deformations and the corresponding locations are provided in Appendix D.

Table 5. Maximum Occupant Compartment Deformations by Location

LOCATION	MAXIMUM DEFORMATION in. (mm)	MASH ALLOWABLE DEFORMATION in. (mm)
Wheel Well & Toe Pan	½ in. (13 mm)	≤ 9 (229)
Floorpan & Transmission Tunnel	½ in. (13 mm)	≤ 12 (305)
Side Front Panel (in Front of A-Pillar)	¼ in. (6 mm)	≤ 12 (305)
Side Door (Above Seat)	¼ in. (6 mm)	≤ 9 (229)
Side Door (Below Seat)	¼ in. (6 mm)	≤ 12 (305)
Roof	0 in. (0 mm)	≤ 4 (102)
Windshield	0 in. (0 mm)	≤ 3 (76)

The majority of the damage was concentrated on the left-front corner and left side of the vehicle. Contact marks were found along the entire length of the left side of the vehicle and from the right-front bumper to the right-front wheel well. Dents were found on the front bumper and fenders and kinks were found on the bottom of the left-front fender. The left and right headlights disengaged. The left-front wheel assembly disengaged from the control arms and the lower portion of the spindle cracked. Tears 2 in. (51 mm) in length and contact marks were found on the left-front wheel extending from the rim, and contact marks appeared along the outer wall of the tire. Tearing occurred on the back of the left-front wheel well. A 1½-in. (38-mm) deep dent was found on the left-front fender at the back of the wheel. A ¾-in. (19-mm) separation formed between the roof and the left-front door. A small dent was found 14 in. (356 mm) from the bottom of the C-pillar. Denting appeared along the entire length of the left quarter panel. The left taillight partially disengaged, and a 1-in. (25-mm) deep dent was found on the left side of the rear bumper.

5.7 Occupant Risk

The calculated occupant impact velocities (OIVs) and maximum 0.010-sec occupant ridedown accelerations (ORAs) in both the longitudinal and lateral directions are shown in Table 6. Note that the OIVs and ORAs were within the suggested limits provided in MASH. The calculated THIV, PHD, and ASI values are also shown in Table 6. The results of the occupant risk analysis, as determined from the accelerometer data, are summarized in Figure 20. The recorded data from the accelerometers and the rate transducers are shown graphically in Appendix E. Note, the SLICE-1 unit was designated as the primary unit during the test, as it was closer to the CG of the vehicle.

Table 6. Summary of OIV, ORA, THIV, PHD, and ASI Values, Test No. MGSS-1

Evaluation Criteria		Transducer		MASH Limits
		SLICE-1 (Primary)	SLICE-2	
OIV ft/s (m/s)	Longitudinal	-3.83 (-1.17)	-3.69 (-1.12)	±40 (12.2)
	Lateral	3.87 (1.18)	4.12 (1.26)	±40 (12.2)
ORA g's	Longitudinal	-6.96	-7.14	±20.49
	Lateral	5.19	5.41	±20.49
MAXIMUM ANGULAR DISPLACEMENT deg.	Roll	-13.10	-10.85	±75
	Pitch	-4.62	-3.86	±75
	Yaw	36.95	36.40	not required
THIV ft/s (m/s)		16.93 (5.16)	17.49 (5.33)	not required
PHD g's		7.67	7.39	not required
ASI		0.49	0.48	not required

5.8 Load Cells

The pertinent data from the load cells was extracted from the bulk signal and analyzed using the transducer's calibration factor. The recorded data and analyzed results are detailed in Appendix F. The exact moment of impact could not be determined from the transducer data as impact may have occurred a few milliseconds prior to a measurable signal increase in the data. Thus, the extracted data curves should not be taken as precise time after impact, but rather a general time line between events within the data curve itself.

5.9 Discussion

The analysis of the test results for test no. MGSS-1 showed that the standard MGS placed at the slope break point of a 1V:2H slope adequately contained and redirected the 2270P vehicle with controlled lateral displacements of the barrier. Detached elements or fragments did not show potential for penetrating the occupant compartment or present undue hazard to other traffic. Deformations of, or intrusions into, the occupant compartment that could have caused serious injury did not occur. The test vehicle did not penetrate or ride over the barrier and remained upright during and after the collision. Vehicle roll, pitch, and yaw angular displacements, as shown in Appendix E, were deemed acceptable, because they did not adversely influence occupant risk safety criteria or cause rollover. After impact, the vehicle exited the barrier at an angle of 16 degrees, and its trajectory did not violate the bounds of the exit box. Therefore, test no. MGSS-1, conducted on the standard MGS placed at the slope break point of a 1V:2H fill slope with 6-ft posts, was determined to be acceptable according to the MASH safety performance criteria for test designation no. 3-11.

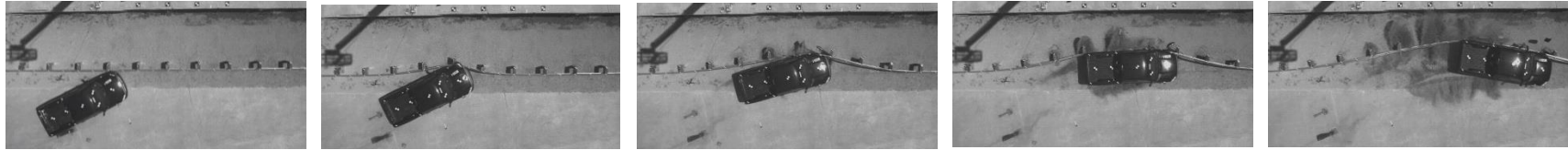

0.000 sec

0.078 sec

0.190 sec

0.280 sec

0.454 sec

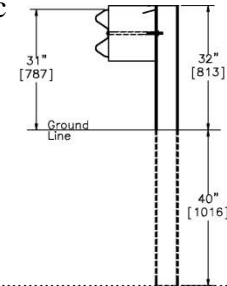
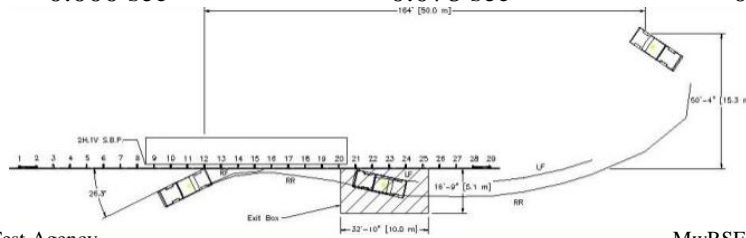

- Test AgencyMwRSF
- Test Number.....MGSS-1
- Date8/14/14
- MASH Test Designation3-11
- Test Article.....Standard MGS at SBP of 1V:2H Slope
- Total Length175 ft (53.3 m)
- Key Component – Steel W-Beam Guardrail
 - Thickness.....12 gauge (2.66 mm)
 - Top Mounting Height31 in. (787 mm)
- Key Component – Steel Post
 - ShapeW6 x 8.5 (W152 x 12.6)
 - Length72 in. (1,829 mm)
 - Post Spacing75 in. (1,905 mm)
 - Embedment Depth.....40 in. (1,016 mm)
- Key Component – Wood Blockout
 - Post Nos. 9-206 x 12 x 14¼ in. (152 x 203 x 362 mm)
- Soil TypeCoarse Crushed Limestone
- Vehicle Make /Model.....2007 Dodge Ram 1500
 - Curb.....5,024 lb (2,279 kg)
 - Test Inertial.....4,992 lb (2264 kg)
 - Gross Static.....5,158 lb (2,340 kg)
- Impact Conditions
 - Speed61.6 mph (99.2 km/h)
 - Angle (Trajectory)26.3 deg
 - Impact Location.....18 ft – 6 in. (3.7 m) Upstream from Centerline of Post No. 15
- Impact Severity (IS)123.7 kip-ft (167.7 kJ) > 105.6 kip-ft (143.2 kJ)
- Exit Conditions
 - Speed40.5 mph (65.1 km/h)
 - Angle16 deg
- Exit Box CriterionPass
- Vehicle Stability.....Satisfactory
- Vehicle Stopping Distance164 ft (50 m) downstream
.....50 ft 4in. (15.3 m) laterally behind rail

- Vehicle Damage.....Minimal
 - VDS [22]11-LFQ-3
 - CDC [23].....11-LFEN-5
 - Maximum Interior Deformation½ in. (13 mm)
- Test Article DamageModerate
- Maximum Test Article Deflections
 - Permanent Set56 in. (1,422 mm)
 - Dynamic72.9 in. (1,852 mm)
 - Working Width.....77.4 in. (1,966 mm)
- Transducer Data

Evaluation Criteria		Transducer		MASH Limit
		SLICE-1 (Primary)	SLICE-2	
OIV ft/s (m/s)	Longitudinal	-3.83 (-1.17)	-3.69 (-1.12)	±40 (12.2)
	Lateral	3.87 (1.18)	4.12 (1.26)	±40 (12.2)
ORA g's	Longitudinal	-6.96	-7.14	±20.49
	Lateral	5.19	5.41	±20.49
MAX. ANGULAR DISP. deg.	Roll	-13.10	-10.85	±75
	Pitch	-4.62	-3.86	±75
	Yaw	36.95	36.40	not required
THIV – ft/s (m/s)		16.93 (5.16)	17.49 (5.33)	not required
PHD – g's		7.67	7.39	not required
ASI		0.49	0.48	not required

Figure 20. Summary of Test Results and Sequential Photographs, Test No. MGSS-1



0.000 sec



0.052 sec



0.108 sec



0.248 sec



0.402 sec



0.650 sec



0.000 sec



0.108 sec

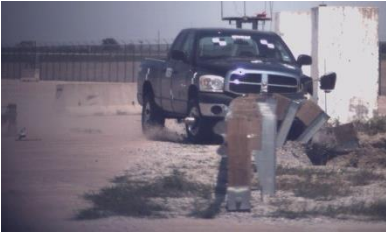

0.198

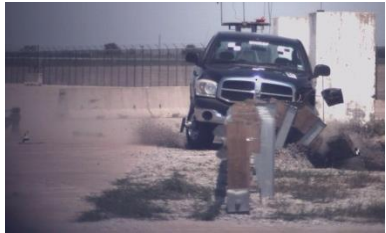

0.280 sec

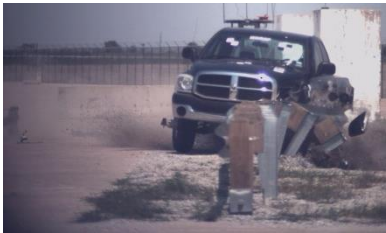

0.452 sec



0.966 sec

Figure 21. Additional Sequential Photographs, Test No. MGSS-1



0.000 sec



0.080 sec



0.242 sec



0.322 sec



0.454 sec



0.752 sec



0.000 sec



0.074 sec



0.168 sec



0.322 sec



0.454 sec



0.650 sec

Figure 22. Additional Sequential Photographs, Test No. MGSS-1



0.000 sec

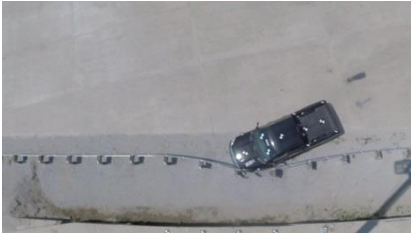

0.117 sec

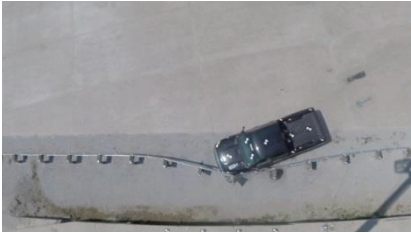

0.150 sec



0.317 sec

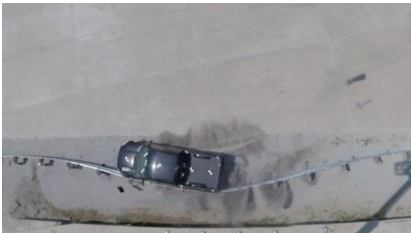

0.400 sec



0.733 sec



0.000 sec



0.092 sec



0.175 sec



0.275 sec



0.425 sec



0.675 sec

Figure 23. Additional Sequential Photographs, Test No. MGSS-1



Figure 24. Impact Location, Test No. MGSS-1



Figure 25. Vehicle Final Position and Trajectory Marks, Test No. MGSS-1



Figure 26. System Damage, Test No. MGSS-1



47

Figure 27. System Damage, Test No. MGSS-1



Figure 28. System Damage Between Post Nos. 12 and 17, Test No. MGSS-1



Figure 29. Post Damage Between Post Nos. 12 and 15, Test No. MGSS-1



Figure 30. Post Damage Between Post Nos. 15 and 18, Test No. MGSS-1



51

Figure 31. Upstream and Downstream Anchor Damage, Test No. MGSS-1



52



Figure 32. Vehicle Damage, Test No. MGSS-1

6 SUMMARY, CONCLUSIONS, AND RECOMMENDATIONS

The standard MGS that was placed at the slope break point of a 1V:2H slope was crash tested and evaluated according to MASH. The MGS utilized 6-ft (1,829-mm) long W6x8.5 (W152x12.6) steel posts spaced at 75 in. (1905 mm). One full-scale crash test was performed according to the TL-3 safety performance criteria, as defined in MASH. Test no. MGSS-1 (test designation no. 3-11) consisted of a 4,992-lb (2,264-kg) pickup truck impacting the MGS at a speed of 61.6 mph (99.1 km/h) and an angle of 26.3 degrees for an impact severity of 123.7 kip-ft (167.7 kJ). The vehicle was contained and smoothly redirected. Thus, the standard MGS placed at the slope break point of a 1V:2H slope was acceptable according to the safety performance criteria presented in MASH. A summary of the safety performance evaluation is provided in Table 7.

The successful evaluation of the standard MGS placed at the slope break point of a 1V:2H slope prevents the need to offset the system laterally away from the slope break point when using standard length steel posts. Full-scale crash testing of the standard MGS installed at the slope break point of a 1V:2H fill slope resulted in a working width of 77.4 in. (1,966 mm). Thus, a minimum lateral distance of approximately 78 in. (1,981 mm) should be provided between the front face of any fixed object and the front face of the MGS system.

The MGS placed at the slope break point of a 1V:2H slope has been successfully crash tested according to the safety performance criteria presented in MASH with two different post lengths, 9-ft (2,743-mm) and 6-ft (1,829-mm) long W6x8.5 (W152x12.6) steel posts. Results of test designation no. 3-11 for the two MGS systems placed as the slope break point of a 1V:2H slope are summarized in Table 8.

Table 7. Summary of Safety Performance Evaluation Results

Evaluation Factors	Evaluation Criteria	Test No. MGSS-1	
Structural Adequacy	A. Test article should contain and redirect the vehicle or bring the vehicle to a controlled stop; the vehicle should not penetrate, underide, or override the installation although controlled lateral deflection of the test article is acceptable.	S	
Occupant Risk	D. Detached elements, fragments or other debris from the test article should not penetrate or show potential for penetrating the occupant compartment, or present an undue hazard to other traffic, pedestrians, or personnel in a work zone. Deformations of, or intrusions into, the occupant compartment should not exceed limits set forth in Section 5.3 and Appendix E of MASH.	S	
	F. The vehicle should remain upright during and after collision. The maximum roll and pitch angles are not to exceed 75 degrees.	S	
	H. Occupant Impact Velocity (OIV) (see Appendix A, Section A5.3 of MASH for calculation procedure) should satisfy the following limits:	S	
	Occupant Impact Velocity Limits		
	Component		Preferred
Longitudinal and Lateral	30 ft/s (9.1 m/s)	40 ft/s (12.2 m/s)	
I. The Occupant Ridedown Acceleration (ORA) (see Appendix A, Section A5.3 of MASH for calculation procedure) should satisfy the following limits:	S		
Occupant Ridedown Acceleration Limits			
Component		Preferred	Maximum
Longitudinal and Lateral	15.0 g's	20.49 g's	
MASH Test Designation Number		3-11	
Pass/Fail		Pass	

S – Satisfactory U – Unsatisfactory NA - Not Applicable

Table 8. Comparison of MGS with 9-ft (2.7 m) and 6-ft (1.8 m) Long Posts

Comparison of Results		Test No. 3-11	
		MGS with 9-ft (2.7 m) Long Posts	MGS with 6-ft (1.8 m) Long Posts
Reference Number		[3]	[this report]
Speed, mph (km/h)		63.1 (101.5)	61.6 (99.2)
Angle, deg		25.5	26.3
Impact Severity, kip-ft (kJ)		122.5 (166.0)	123.7 (167.7)
Test Article Deflections, in. (mm)	Dynamic	57.6 (1,463)	72.9 (1,852)
	Permanent Set	42 (1,067)	56 (1,422)
	Working Width	64.2 (1,631)	77.4 (1,966)
OIV, ft/s (m/s)	Longitudinal	-13.90 (-4.24)	-3.83 (-1.17)
	Lateral	13.61 (4.15)	3.87 (1.18)
ORA, g's	Longitudinal	-5.36	-6.96
	Lateral	5.28	5.19
Maximum Occupant Compartment Deformation, in. (mm)		0.5 (13)	0.5 (13)
Maximum Angular Displacement, deg.	Roll	Est. 6	-13.10
	Pitch	Est. 5	-4.62
	Yaw	Est. 45	36.95

7 IMPLEMENTATION GUIDANCE

As previously noted, the research detailed herein demonstrated that a standard MGS with 6-ft (1,829-mm) long, W6x8.5 (w152x12.6) steel posts performed in an acceptable manner when installed at the slope break point of a 1V:2H slope according to test designation no. 3-11 of the MASH impact safety standards. Several variations of the MGS system have been developed for special applications, which may be more sensitive to this type of installation adjacent to slopes. These special applications would include the MGS long-span system [24-25], MGS with various wood posts [10-13, 26], MGS on 8H:1V approach slopes [27], MGS adjacent to a curb [28-30], MGS stiffness transition to approach guardrail transitions [31-34], MGS with reduced post spacing [28-30], and MGS without blockouts [15-16]. Since several MGS variations are available, recommendations regarding the use of the MGS adjacent to a 1V:2H slope with standard, 6-ft (1,829-mm) long steel posts will likely vary depending on the nature and behavior of the special applications listed above.

The following sections provide suggested implementation guidance and/or recommendations regarding the tested system and use with other MGS special applications. These recommendations are intended to ensure comparable safety performance of the guardrail systems and are based on the full-scale testing and any associated research available at the conclusion of this project. Although some installation sites will require systems outside the bounds of these recommendations, the reasoning behind these recommendations should be considered along with other roadside treatments when selecting the final site specific design.

7.1 Soil Foundation

The soil foundation of the posts affects post-soil resistive forces, thus the strength of the soil is critical for the MGS placed adjacent to a 1V:2H slope. For typical longitudinal barrier designs, it has generally been assumed that the use of strong soils is more critical for full-scale

crash testing and evaluation as strong soils tend to produce higher post-soil resistive forces which tend to create higher rail forces, increased snag on barrier support posts, and higher occupant risk values. However, in the case of the MGS installed at the slope break point of a 1V:2H slope with standard, 6-ft (1,829-mm) long steel posts, the soil resistive forces of the standard system are being reduced by a combination of shallow post embedment and slope effects. Insufficient soil support can lead to excessive guardrail post movements and guardrail lateral deflection during vehicle collision, potentially resulting in a lower capacity to contain and redirect errant vehicles on slopes. Thus, the use of a strong soil in this situation may not be critical, as it may actually improve system capacity in this sloped configuration with shallow post embedment.

MASH accounts for the use of weak or reduced strength soils in the evaluation of certain barrier systems. MASH provides the following guidance with respect to the use of alternative soils. Quoting directly from MASH:

3.3 Soil

Impact performance of some soil-mounted features depends on dynamic soil structure interaction. Longitudinal barriers with soil embedded posts and soil-embedded support structures for signs and luminaires are such features. When feasible, these features should be tested with soil conditions that replicate typical in-service conditions. Soil conditions are known to vary with time, location, and environmental factors, even within relatively small geographical areas. Therefore, except for special test conditions, it is necessary to standardize soil conditions for testing. In the absence of a specific soil, it is recommended that all features whose impact performance is sensitive to soil-structure interaction be tested in a soil that conforms to the performance specification as described in Section 3.3.1. However, product developers and user agencies should assess the

potential sensitivity of a feature to foundation conditions. If the feature is likely to be installed in a soil that could be expected to degrade its performance, testing in one or more of the special soils described in Section 3.3.3 may be appropriate.

A3.3.1 Standard Soil

Unless the test article is limited to areas of weak soils, the standard soil should be used with any feature whose impact performance is sensitive to soil-foundation or soil-structure interaction. A large percentage of previous testing has been performed in similar soil and a historical tie is needed. Although it is probably stronger than the average condition found along the roadside, it is still representative of a considerable amount of existing installations.

A3.3.3 Special Soils

The weak soil should be used, in addition to the standard soil, for any feature whose impact performance is sensitive to soil-foundation or soil-structure interaction if: (a) identifiable areas of the state or local jurisdiction in which the feature will be installed contain soil with similar properties, and (b) there is a reasonable uncertainty regarding performance of the feature in the weak soil. Tests have shown that some base-bending or yielding small sign supports readily pull out of the weak soil upon impact. For features of this type, the strong soil is generally more critical and tests in the weak soil may not be necessary.

MASH recommends that the system be tested in the standard soil unless the hardware installations are expected to be placed in generally weak soils, and weak soil is expected to degrade performance. Otherwise, it recommends that the standard soil be used as it is believed to be representative of typical soil foundation conditions and provides a historical tie to previous testing. While there was an argument that weak soils may be more critical with respect to the

MGS installed at the slope break point of a 1V:2H slope with standard, 6-ft (1,829-mm) long posts, it was believed that evaluation of such a system should follow the guidance provided in MASH. The system should be evaluated with standard soil based on the fact the general soil condition for a given installation would not be assumed to be weak, and it provides a link to previous testing of guardrails on slope.

However, the concerns noted previously with respect to reduced barrier resistive forces and increased barrier deflection should still be considered when installing this type of system in real-world applications. Installation of the MGS installed at the slope break point of a 1V:2H slope with standard, 6-ft (1,829-mm) long steel posts in soils weaker than those tested may increase barrier deflections. The increased deflections may become excessive and lead to a failure of the system to capture and redirect an impacting vehicle. As such, users may elect to limit installation of the MGS installed at the slope break point of a 1V:2H slope with standard, 6-ft (1,829-mm) long steel posts to areas with similar soil strength to the as-tested system.

Previous testing of the MGS long span system [23] exhibited a dynamic barrier deflection of 92¼ in. (2,343 mm), which is significantly higher than the 72⅞ in. (1,851 mm) observed in test no. MGSS-1. This fact would seem to suggest that the MGS installed at the slope break point of a 1V:2H slope with standard, 6-ft (1,829-mm) long steel posts can accommodate higher deflections than the as-tested system, but the extent of that additional deflection is unknown. End users would also need to compensate for the additional deflection by using more conservative working widths for the system when using lower strength soils.

7.2 Minimum Installation Height

Previous testing of the MGS and the original G4(1S) system under the MASH criteria has suggested that the MGS has a minimum acceptable rail height below its nominal mounting height of 31 in. (787-mm) [14]. The MGS was not actually crash tested at its minimum top rail

height of 27¾ in.(706 mm) using the impact conditions published in MASH. However, the modified G4(1S) W-beam guardrail system was shown to meet the TL-3 criteria found in the MASH with the completion of test no. 2214WB-2 [35]. Previously, it has been demonstrated that the MGS provides improved barrier performance over that observed with the modified G4(1S) barrier system [11, 28-30]. Therefore, it was believed that the MGS will also meet the TL-3 requirements found in the MASH when installed at a top rail height of 27¾ in. (706 mm) when used on level terrain.

Previously, the 31-in. (787-mm) tall MGS with 9-ft (2.74-m) long W6x8.5 (W152x12.6) steel posts was successfully crash tested under the MASH TL-3 criteria when installed at the slope break point of a 1V:2H fill slope using standard post spacing and blockouts [3,5]. However, similar crash testing was not successful for the minimum recommended MGS mounting height of 27¾ in. (706 mm). As such, the minimum recommended top mounting height is unknown for the MGS adjacent to 1V:2H fill slopes.

It should be noted that no crash tests have been performed on the MGS installed at the slope break point of a 1V:2H slope with standard, 6-ft (1,829-mm) long steel posts with reduced rail height. It is believed that the minimum recommended top mounting height would likely be affected, similar to the blocked version of the MGS adjacent to 1V:2H fill slopes. As such, it is highly recommended that the MGS installed at the slope break point of a 1V:2H slope with standard, 6-ft (1,829-mm) long steel posts utilize a minimum top mounting height of 31 in. (787 mm) until further investigation is performed.

7.3 MGS Long-Span Guardrail

The MGS long-span guardrail system was successfully full-scale crash tested using an unsupported length of 25 ft (7.62 m) and three CRT posts with 12-in. (305-mm) deep blockouts adjacent to each end of the unsupported span [24]. These CRT posts were incorporated into the

system in order to mitigate concerns for wheel snag on posts adjacent to the unsupported span when traversing from the unsupported span to the downstream standard guardrail. Adjacent to the CRT posts, the standard MGS utilized 12-in. (305-mm) deep blockouts. The MGS long-span guardrail system was installed with the back of the CRT posts positioned flush with the front face of the culvert headwall. The posts upstream and downstream from the culvert were installed 2 ft (610 mm) away from the slope break point of a 3:1 fill slope.

It may be desirable to apply the MGS installed at the slope break point of a 1V:2H slope with standard, 6-ft (1,829-mm) long steel posts to the MGS long-span guardrail system. There is concern that the use of this type of installation adjacent to a steep slope with the MGS long span may allow for dynamic barrier deflections that are too large for safe vehicle redirection. The MGS long span already has the largest dynamic deflection of any previously-tested MGS application. Combining that system with the MGS installed at the slope break point of a 1V:2H slope with standard, 6-ft (1,829-mm) long steel posts would likely result in even greater barrier deflections. Additionally, the CRT posts used in the MGS long span adjacent to the unsupported rail would behave differently when installed at the slope break point of a 1V:2H slope. The expected increase in barrier deflection could affect vehicle capture and stability to level that is difficult to predict without further research. As such, it is not recommended to apply the MGS installed at the slope break point of a 1V:2H slope with standard, 6-ft (1,829-mm) long steel posts in conjunction with the MGS long span without further analysis and crash testing.

7.4 MGS with an Omitted Post

Recent research at MwRSF consisted of the evaluation of the standard MGS with an omitted post [25]. The omitted post created an unsupported span of 12.5 ft (3.8 m). No other modifications were made to the MGS. One full-scale crash test was performed according to the

TL-3 safety performance criteria defined in MASH, test designation no. 3-11, and the MGS with an omitted post performed in an acceptable and safe manner.

Concerns for the use of the MGS installed at the slope break point of a 1V:2H slope with standard, 6-ft (1,829-mm) long steel posts in combination with an omitted post are similar to those noted previously for the MGS long span. Omission of a post in this type of system would tend to increase rail deflections over the system tested herein, and this increase in deflection could adversely affect the barrier's performance in terms of vehicle capture and stability. As such, it is not recommended to apply the MGS installed at the slope break point of a 1V:2H slope with standard, 6-ft (1,829-mm) long steel posts in combination with a single omitted post without further analysis and crash testing.

7.5 MGS on 8:1 Approach Slopes

Previously, full-scale crash testing was successfully performed on the steel-post version of the MGS installed on an 8:1 approach slope with the W-beam positioned 5 ft (1.52 m) laterally behind the slope break point [27]. This testing program was conducted according to the NCHRP Report No. 350 impact safety standards using both an 820C small car and a 2000P pickup truck. From the crash testing program, the mounting height of the blocked MGS relative to the airborne trajectory of the front bumper and impact-side wheels was deemed critical for satisfactorily containing the 2000P pickup truck. Arguably, the test results may have also demonstrated that the 31-in. (787-mm) top railing height greatly contributed to adequate vehicle containment and stable redirection.

Because the MGS on 8:1 approach slopes has not been evaluated under the MASH criteria, there is uncertainty on how this type of installation would be affected when installed near a 1V:2H slope. It is possible that placement of the 1V:2H slope adjacent to this installation may lead to increased barrier deflection and increased propensity for vehicle instability. As such,

it is not recommended to apply the MGS installed at the slope break point of a 1V:2H slope with standard, 6-ft (1,829-mm) long steel posts in conjunction with the MGS on 8:1 approach slopes without further analysis and crash testing.

7.6 MGS Adjacent to Curb

The standard MGS was successfully crash tested and evaluated with the front face of the W-beam rail placed 6 in. (152 mm) behind the front face of a 6-in. (152-mm) tall concrete curb according to the NCHRP Report No. 350 TL-3 criteria using a 2000P pickup truck [28-29]. The use of the MGS installed at the slope break point of a 1V:2H slope with a concrete curb causes potential concerns with respect to barrier performance. The MGS adjacent to curb was not evaluated under the MASH criteria, so it is unknown for certain how the MGS adjacent to curb performs with respect to the small car and pickup truck impacts required in MASH. Additionally, the effect of the additional barrier deflection expected for an installation at the slope break point of a 1V:2H slope in combination with the impacting vehicle's traversal of the curb during impact and exit with the barrier may pose additional difficulties for safe vehicle redirection that were not evaluated during the NCHRP Report No. 350 testing on level terrain. As such, it is not recommended to apply the MGS installed at the slope break point of a 1V:2H slope with standard, 6-ft (1,829-mm) long steel posts adjacent to curbs without further analysis and crash testing.

7.7 MGS Stiffness Transition to Approach Guardrail Transitions

Several options for approach guardrail transitions for the MGS system have been developed [31-34]. As part of those efforts, a steel-post MGS stiffness transition was found to satisfy all of the TL-3 safety performance criteria of MASH through a full-scale crash testing program. This transition design utilized standard, 6-ft (1,829-mm) long W6x8.5 (W152x12.6) posts for a majority of the upstream stiffness transition. Subsequent bogie testing and BARRIER

VII analysis developed a wood-post transition system that behaved similarly and without increases in deflections, pocketing, or snag. Thus, it was believed that the wood-post transition system would also satisfy the MASH performance criteria, and the wood-post MGS stiffness transition was recommended for use as a TL-3 safety barrier.

The performance of approach guardrail transitions is directly related to the effectiveness of the system in providing a gradual transition in stiffness between the approach guardrail and the bridge parapet or bridge rail. The previously-described MGS transitions were designed to rely on post-soil resistive forces to develop the proper stiffness transition. Installation of this type of transition or portions of the approach guardrail upstream of the transition on 1V:2H slopes could alter the stiffness of the transition system in such a way to compromise the performance of the barrier system. Previous research at MwRSF related to investigation of transition systems installed in a manner which deviated from the as-tested design found that installation of approach guardrail transitions on slopes resulted in increased propensity for increased barrier deflection, rail pocketing, and vehicle snag. As such, it is not recommended to apply the MGS installed at the slope break point of a 1V:2H slope with standard, 6-ft (1,829-mm) long steel posts in any region inside the MGS approach guardrail transition without further analysis and crash testing.

Additionally, previous guidance developed for the MGS approach guardrail transition has noted that a minimum of 25 ft (7.62m) of standard MGS must be required upstream of the asymmetric W-to-thrie beam transition piece prior to deviating to some an MGS special application. Thus, it is recommended that the MGS installed at the slope break point of a 1V:2H slope with standard, 6-ft (1,829-mm) long steel posts be should be placed no closer to the MGS approach guardrail transition than a minimum of 25 ft (7.62m) from the asymmetric W-to-thrie beam transition section, as shown in Figure 33.

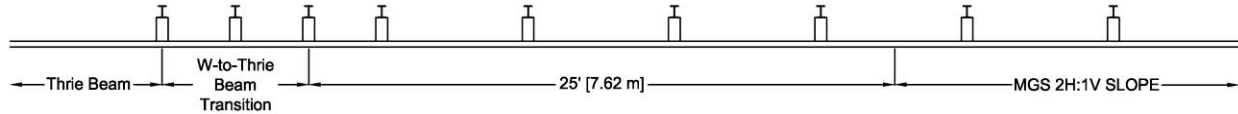

Figure 33. MGS Adjacent to a 1V:2H Slope Offset from W-to-Thrie Beam Transition

7.8 MGS with Reduced Post Spacing

A steel-post version of the MGS with quarter-post spacing was successfully full-scale crash tested and evaluated using a 2000P pickup truck according to the TL-3 criteria found in NCHRP Report No. 350 [28-30]. Subsequent analysis of the barrier system with BARRIER VII was used to develop details for a half-post spacing version of the MGS as well. The use of reduced post spacing for W-beam guardrail adjacent to steep slopes has previously been evaluated under NCHRP Report No. 350 and was found to improve performance over the standard guardrail adjacent to slope due to the increased post-soil resistive forces provides by the more closely spaced support posts [1-2]. Thus, it is reasonable to assume that reduced post spacing would provide similar performance benefits to the MGS installed at the slope break point of a 1V:2H slope with standard, 6-ft (1,829-mm) long steel posts. Reduced post spacing may provide a good alternative for installations where the soil strength is in question and users wish to manage the barrier deflection while still using standard length posts.

7.9 MGS without Blockouts

As noted previously, the 31-in. (787-mm) tall MGS with 9-ft (2.74-m) long W6x8.5 (W152x12.6) steel posts was successfully crash tested under the MASH TL-3 criteria when installed at the slope break point of a 1V:2H fill slope using standard post spacing and blockouts. Additionally, full-scale crash testing was successful on a non-blocked MGS system when installed both on level terrain and adjacent to slopes. A non-blocked MGS installed at the slope break point of a 3:1 fill slope positioned on top of an MSE wall was tested under the MASH TL-

3 safety criteria for both the 1100C and 2270P vehicles [17-18]. Subsequent MASH testing was also successfully performed on a non-blocked MGS installed on level terrain with both the 1100C and 2270P vehicles [15-16]. Comparison of the non-blocked and blocked versions of the MGS found the performance of the standard MGS with 12-in. (305-mm) deep blockouts improved as compared the non-blocked system, and the safety performance of the non-blocked system was acceptable under the MASH criteria.

Using the results from these successful crash testing programs, it is believed that satisfactory performance would also be provided by a non-blocked version of the MGS when installed at the slope break point of a 1V:2H slope with standard, 6-ft (1,829-mm) long steel posts, as shown in Figure 34.

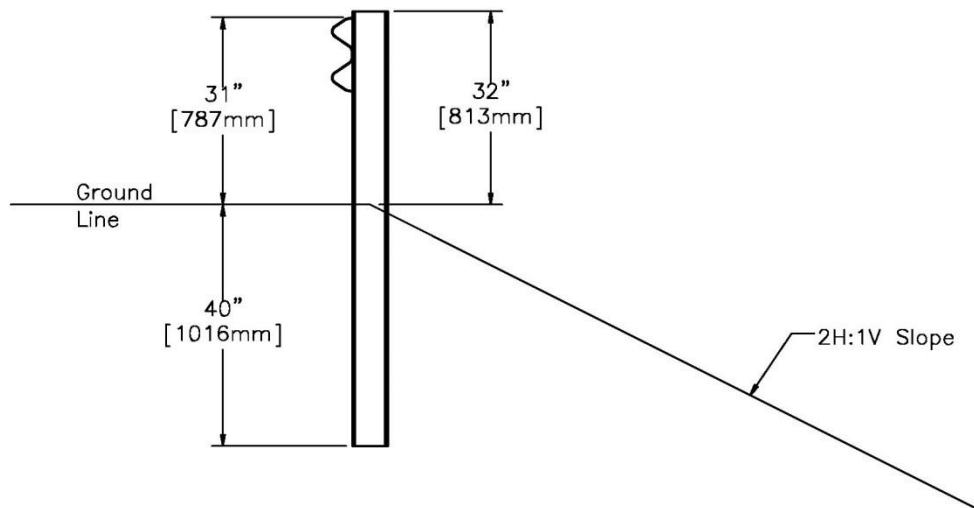

Figure 34. MGS Adjacent to a 1V:2H Slope without Blockouts

7.10 MGS with Wood Posts

Over the years, MwRSF has crash tested several wood-post MGS systems, including rectangular, Southern Yellow Pine (SYP) wood posts and alternative wood species round and rectangular posts [12-13,26]. Comparison of MASH crash testing with both steel and rectangular

wood posts found that the performance of the MGS system with steel and rectangular SYP wood posts was found to correlate very well [12-13]. Dynamic deflections, working widths, occupant risk values, and vehicle stability measures were generally unaffected by the change in the post type. Only minor differences in the system behavior were found, and no concerns were identified that suggested that one system had a safety performance advantage over the other. Thus, it was concluded that the 6-in. wide x 8-in. deep x 72-in. long (152-mm wide x 203-mm deep x 1829-mm long) wood-post and W6x8.5 x 72-in. (W152x12.6 x 1829-mm long) long steel-post MGS systems provide equivalent safety performance. Based on the similar performance observed for the wood- and steel-post MGS systems, there may be a desire for end users to install a wood post MGS installed at the slope break point of a 1V:2H slope with standard, 6-ft (1,829-mm) long posts.

The 31-in. (787-mm) tall MGS with 9-ft (2.74-m) long W6x8.5 (W152x12.6) steel posts was successfully crash tested under the MASH TL-3 criteria when installed at the slope break point of a 1V:2H fill slope using standard post spacing and blockouts and was also approved with 8-ft (2.44-m) long W6x8.5 (W152x12.6) steel posts [3]. Later and based on dynamic component testing, a wood post version of the MGS system was configured with 7.5-ft (2,286-mm) long, SYP posts and for use in shielding a 1V:2H fill slope [4]. For the SYP wood post variation, the embedment depth was 58 in. (1,473 mm).

Based on this previous research, it would seem reasonable that a rectangular, SYP wood post MGS installed at the slope break point of a 1V:2H slope that utilized standard, 6-ft (1,829-mm) long posts would perform similarly to the steel post version tested herein. Thus, it is recommended that the MGS with 6-in. wide x 8-in. deep x 72-in. long (152-mm wide x 203-mm deep x 1829-mm long) SYP posts may be installed at the slope break point of a 1V:2H slope, as shown in Figure 35.

Similarly, the MGS was successfully evaluated under the MASH criteria when installed with 6-in. wide x 8-in. deep x 72-in. long (152-mm wide x 203-mm deep x 1829-mm long) white pine posts [26]. At the time of that research, MwRSF recommended that a white pine MGS system located adjacent to a 1V:2H fill slope should utilize 6.5-ft (1,981-mm) long, 6-in. x 8-in. (152-mm x 203-mm) wood posts at half-post spacing, or on 37½ in. (953 mm) centers. This post length was shorter when compared to the SYP posts adjacent to slope in order to prevent post fracture of the lower strength white pine while still providing adequate post soil resistive forces. The testing of the MGS installed at the slope break point of a 1V:2H slope with standard, 6-ft (1,829-mm) long steel posts detailed herein suggests that further reduction in post embedment is acceptable. Thus, it is believed that the MGS with 6-in. wide x 8-in. deep x 72-in. long (152-mm wide x 203-mm deep x 1829-mm long) white pine posts may be installed at the slope break point of a 1V:2H slope as well.

As noted above, other testing and evaluation of wood posts has been conducted with the MGS. Several alternative species of round, wood posts have been evaluated with the MGS based on NCHRP Report No. 350 testing. Because these posts have different strengths, embedment, and geometry from the standard 6-in. wide x 8-in. deep x 72-in. long (152-mm wide x 203-mm deep x 1829-mm long) SYP post, and they have not been evaluated with the MGS under the MASH criteria, it is not recommended to use the standard length, alternative species, round wood posts adjacent to a 1V:2H slope without further analysis.

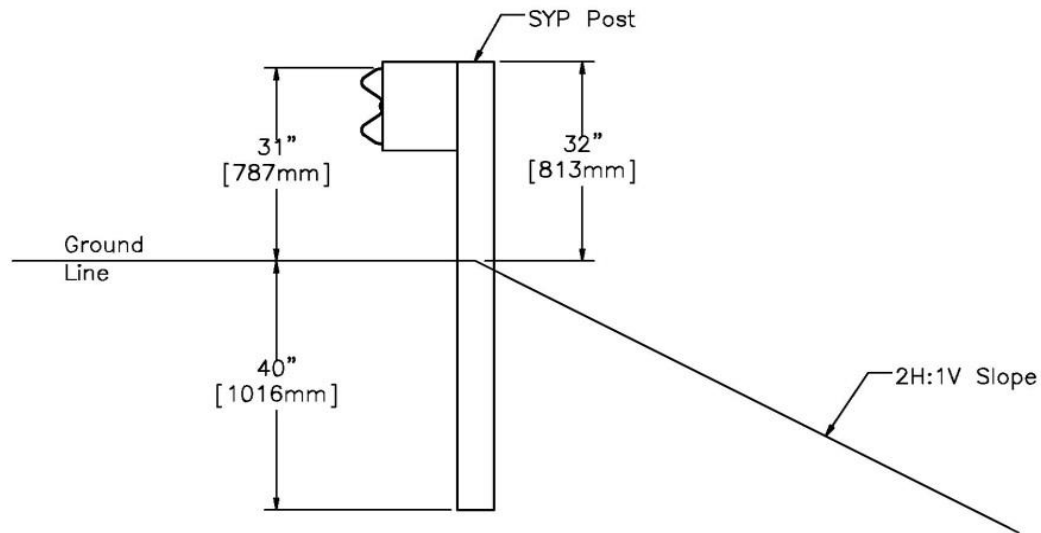

Figure 35. MGS Adjacent to a 1V:2H Slope with SYP Rectangular Posts

7.11 Guardrail End Terminals

Finally, there may be a desire to implement the MGS installed at the slope break point of a 1V:2H slope with standard, 6-ft (1,829-mm) long steel posts near the ends of guardrail systems, which are typically anchored with some form of crashworthy end terminal or end anchorage. Installation of anchorage systems, such as generic, trailing end anchorages, directly adjacent to a 1V:2H slope is not recommended as the reduction in soil near the anchorage may adversely affect its ability to develop the necessary tensile loads to restrain the barrier system and redirect impacting vehicles. Additionally, 1V:2H slopes are not considered to be safely traversable, thus any guardrail system shielding this type of slope should provide anchorage outside the sloped area.

Crashworthy end terminals require specific grading requirements to function properly in the area surrounding the end terminal. As such, it is recommended that guidance from the

individual end terminal manufacturer be followed with respect to placement of these systems adjacent to slopes.

8 REFERENCES

1. Polivka, K.A., Faller, R.K., Sicking, D.L., Rohde, J.R., Holloway, J.C., and Keller, E.A., *Development of a W-Beam Guardrail System for Use on a 2:1 Slope*, Final Report to the Midwest States Regional Pooled Fund Program, Research Report no. TRP-03-99-00, Midwest Roadside Safety Facility, University of Nebraska-Lincoln, Lincoln, Nebraska, October 16, 2000.
2. Polivka, K.A., Sicking, D.L., Faller, R.K., and Rohde, J.R., *A W-Beam Guardrail Adjacent to a Slope*, Paper No. 01-0343, Transportation Research Record No. 1743, Journal of the Transportation Research Board, Transportation Research Board, Washington, D.C., January 2001.
3. Wiebelhaus, M.J., Lechtenberg, K.A., Faller, R.K., Sicking, D.L., Bielenberg, R.W., Reid, J.D., Rohde, J.R., and Dey, G., *Development and Evaluation of the Midwest Guardrail System (MGS) Placed Adjacent to a 2:1 Fill Slope*, Research Report No. TRP-03-185-10, Final Report to the Midwest States Regional Pooled Fund Program, Project No. SPR-3(017)-Year 15, Project Code: RPPF-05-09, Midwest Roadside Safety Facility, University of Nebraska-Lincoln, Lincoln, Nebraska, February 24, 2010.
4. McGhee, M.D., Lechtenberg, K.A., Bielenberg, R.W., Faller, R.K., Sicking, D.L., and Reid, J.D., *Dynamic Impact Testing of Wood Posts for the Midwest Guardrail System (MGS) Placed Adjacent to a 2H:1V Fill Slope*, Research Report No. TRP-03-234-10, Final Report to the Midwest Regional Pooled Fund Program, Midwest Roadside Safety Facility, University of Nebraska-Lincoln, Lincoln, Nebraska, December 16, 2010.
5. Polivka, K.A., Faller, R.K., Sicking, D.L., and Bielenberg, R.W., *Midwest Guardrail System Adjacent to a 2:1 Slope*, Paper No. 08-3076, Transportation Research Record No. 2060, Journal of the Transportation Research Board, Transportation Research Board, Washington D.C., January 2008.
6. *Manual for Assessing Safety Hardware (MASH)*, American Association of State Highway and Transportation Officials (AASHTO), Washington, D.C., 2009.
7. Mongiardini, M., Faller, R.K., Reid, J.D., Sicking, D.L., Stolle, C.S., and Lechtenberg, K.A., *Downstream Anchoring Requirements for the Midwest Guardrail System*, Final Report to Wisconsin Department of Transportation, Research Report No. TRP-03-279-13, Midwest Roadside Safety Facility, University of Nebraska-Lincoln, Lincoln, Nebraska, October 28, 2013.
8. Mongiardini, M., Faller, R.K., Reid, J.D., and Sicking, D.L., *Dynamic Evaluation and Implementation Guidelines for a Non-Proprietary W-Beam Guardrail Trailing End Terminal*, Transportation Research Record No. 2377, Journal of the Transportation Research Board, Transportation Research Board, National Research Council, Washington, D.C., November 2013.

9. Stolle, C.S., Reid, J.D., Faller, R.K., and Mongiardini, M., *Dynamic Strength of a Modified W-beam BCT Trailing-End Termination System*, International Journal of Crashworthiness, DOI: 10.10980/13588265.2015.1009308, February 2015.
10. Polivka, K.A., Faller, R.K., Sicking, D.L., Rohde, J.R., Bielenberg, R.W., and Reid, J.D., *Performance Evaluation of the Midwest Guardrail System – Updated to NCHRP 350 Test No. 3-10 (2214MG-3)*, Final Report to the National Cooperative Highway Research Program, Project No. NCHRP 22-14(2), Research Report No. TRP-03-172-06, Midwest Roadside Safety Facility, University of Nebraska-Lincoln, Lincoln, Nebraska, October 11, 2006.
11. Faller, R.K., Sicking, D.L., Bielenberg, R.W., Rohde, J.R., Polivka, K.A., and Reid, J.D., *Performance of Steel-Post W-Beam Guardrail Systems*, Paper No. 07-2642, Transportation Research Record No. 2025, Journal of the Transportation Research Board, Transportation Research Board, Washington D.C., January 2007.
12. Gutierrez, D.A., Lechtenberg, K.A., Bielenberg, R.W., Faller, R.K., Reid, J.D., and Sicking, D.L., *Midwest Guardrail System (MGS) with Southern Yellow Pine Posts*, Final Report to Midwest States Pooled Fund Program, Research Report No. TRP-03-272-13, Midwest Roadside Safety Facility, University of Nebraska-Lincoln, Lincoln, Nebraska, September 4, 2013.
13. Bielenberg, R.W., Faller, R.K., Reid, J.D., Rosenbaugh, S.K., and Lechtenberg, K.A., *Performance of Midwest Guardrail System with Rectangular Wood Posts*, Paper No. 14-2991, Transportation Research Record No. 2437, Journal of the Transportation Research Board, Transportation Research Board, Washington D.C., January 2014.
14. Stolle, C.J., Lechtenberg, K.A., Reid, J.D., Faller, R.K., Bielenberg, R.W., Rosenbaugh, S.K., Sicking, D.L., and Johnson, E.A., *Determination of the Maximum MGS Mounting Height – Phase I Crash Testing*, Final Report to Midwest States Pooled Fund Program, Research Report No. TRP-03-255-12, Midwest Roadside Safety Facility, University of Nebraska-Lincoln, Lincoln, Nebraska, March 9, 2012.
15. Schrum, K.D., Lechtenberg, K.A., Bielenberg, R.W., Rosenbaugh, S.K., Faller, R.K., Reid, J.D., and Sicking, D.L., *Safety Performance Evaluation of the Non-Blocked Midwest Guardrail System (MGS)*, Final Report to Midwest States Pooled Fund Program, Research Report No. TRP-03-262-12, Midwest Roadside Safety Facility, University of Nebraska-Lincoln, Lincoln, Nebraska, January 24, 2013.
16. Reid, J.D., Faller, R.K., Bielenberg, R.W., and Lechtenberg, K.A., *Midwest Guardrail System without Blockouts*, Paper No. 13-0418, Transportation Research Record No. 2377, Journal of the Transportation Research Board, Transportation Research Board, Washington D.C., January 2013.
17. McGhee, M.D., Faller, R.K., Rohde, J.R., Lechtenberg, K.A., Sicking, D.L., and Reid, J.D., *Development of an Economical Guardrail System for Use on Wire-Faced, MSE Walls*, Draft Final Report to the Federal Highway Administration, Central Federal Lands Highway

Division, Research Report No. TRP-03-235-11, Midwest Roadside Safety Facility, University of Nebraska-Lincoln, Lincoln, Nebraska, February 2012.

18. Lechtenberg, K.A., Faller, R.K., Sicking, D.L., Rohde, J.R., and Reid, J.D., *Non-blocked, Midwest Guardrail System for Wire-Faced Walls of Mechanically Stabilized Earth*, Paper No. 11-2684, Transportation Research Record No. 2262, Journal of the Transportation Research Board, Transportation Research Board, Washington D.C., January 2011.
19. Hinch, J., Yang, T.L., and Owings, R., *Guidance Systems for Vehicle Testing*, ENSCO, Inc., Springfield, Virginia, 1986.
20. *Center of Gravity Test Code - SAE J874 March 1981*, SAE Handbook Vol. 4, Society of Automotive Engineers, Inc., Warrendale, Pennsylvania, 1986.
21. Society of Automotive Engineers (SAE), *Instrumentation for Impact Test – Part 1 – Electronic Instrumentation*, SAE J211/1 MAR95, New York City, NY, July, 2007.
22. *Vehicle Damage Scale for Traffic Investigators*, Second Edition, Technical Bulletin No. 1, Traffic Accident Data (TAD) Project, National Safety Council, Chicago, Illinois, 1971.
23. *Collision Deformation Classification – Recommended Practice J224 March 1980*, Handbook Volume 4, Society of Automotive Engineers (SAE), Warrendale, Pennsylvania, 1985.
24. Bielenberg, R.W., Faller, R.K., Rohde, J.R., Reid, J.D., Sicking, D.L., Holloway, J.C., Allison, E.M., and Polivka, K.A., *Midwest Guardrail System for Long-Span Culvert Applications*, Research Report No. TRP-03-187-07, Final Report to the Midwest States Regional Pooled Fund Program, Project No. SRP-3(017)-Year 15, Project Code RPPF-05-04, Midwest Roadside Safety Facility, University of Nebraska-Lincoln, Lincoln, Nebraska, November 16, 2007.
25. Lingenfelter, J.L., Rosenbaugh, S.K., Bielenberg, R.W., Lechtenberg, K.A., Faller, R.K., and Reid, J.D., *Midwest Guardrail System (MGS) with an Omitted Post*, Research Report No. 03-326-16, Report to the Midwest States Regional Pooled Fund Program, Project No. TPF-5(193)-Year25, Project Code RPPF-15-MGS-5, Midwest Roadside Safety Facility, University of Nebraska-Lincoln, Lincoln, Nebraska, January 21, 2016.
26. Stolle, C.J., Lechtenberg, K.A., Faller, R.K., Rosenbaugh, S.K., Sicking, D.L., and Reid, J.D., *Evaluation of the Midwest Guardrail System (MGS) with White Pine Wood Posts*, Research Report No. TRP-03-241-11, Final Report to the Wisconsin Department of Transportation, Midwest Roadside Safety Facility, University of Nebraska-Lincoln, Lincoln, Nebraska, March 28, 2011.
27. Lechtenberg, K.A., Reid, J.D., Sicking, D.L., Faller, R.K., Bielenberg, R.W., and Rohde, J.R., *Approach Slope for Midwest Guardrail System*, Research Report No. TRP-03-188-08, Final Report to the Midwest States Regional Pooled Fund Program, Project No. SPR-3(017)-Years 14 and 15, Project Code RPPF-04-04 and 05-06, Midwest Roadside Safety Facility, University of Nebraska-Lincoln, Lincoln, Nebraska, December 4, 2008.

28. Polivka, K.A., Faller, R.K., Sicking, D.L., Reid, J.D., Rohde, J.R., Holloway, J.C., Bielenberg, R.W., and Kuipers, B.D., *Development of the Midwest Guardrail System (MGS) for Standard and Reduced Post Spacing and in Combination with Curbs*, Research Report No. TRP-03-139-04, Final Report to the Midwest States Regional Pooled Fund Program, Project No. SRP-3(017)-Years 10, and 12-13, Project Code: RPPF-00-02-01 and 03-05, Midwest Roadside Safety Facility, University of Nebraska-Lincoln, Lincoln, Nebraska, September 1, 2004.
29. Faller, R.K., Polivka, K.A., Kuipers, B.D., Bielenberg, B.W., Reid, J.D., Rohde, J.R., and Sicking, D.L., *Midwest Guardrail System for Standard and Special Applications*, Transportation Research Record No. 1890, Journal of the Transportation Research Board, TRB AFB20 Committee on Roadside Safety Design, Transportation Research Board, Washington, D.C., January 2004.
30. Sicking, D.L., Reid, J.D., and Rohde, J.R., *Development of the Midwest Guardrail System*, Paper No. 02-3157, Transportation Research Record No. 1797, Journal of the Transportation Research Board, TRB AFB20 Committee on Roadside Safety Design, Transportation Research Board, Washington, D.C., January 2004.
31. Eller, C.M., Polivka, K.A., Faller, R.K., Sicking, D.L., Rohde, J.R., Reid, J.D., Bielenberg, R.W., and Allison, E.M., *Development of the Midwest Guardrail System (MGS) W-Beam to Thrie Beam Transition Element*, Research Report No. TRP-03-167-07, Final Report to the Midwest States Regional Pooled Fund Program, Project No. SPR-3(017)-Years 11-12 and 16, Project Code RPPF-01-04, 02-05 and 06-04, Midwest Roadside Safety Facility, University of Nebraska-Lincoln, Lincoln, Nebraska, November 26, 2007.
32. Rosenbaugh, S.K., Lechtenberg, K.A., Faller, R.K., Sicking, D.L., Bielenberg, R.W., and Reid, J.D., *Development of the MGS Approach Guardrail Transition Using Standardized Steel Posts*, Research Report No. TRP-03-210-10, Final Report to the Midwest States Regional Pooled Fund Program, Project No. SPR-3(017) and TPF-5(193)-Years 18 and 19, Project Code RPPF-08-05 and 09-03, Midwest Roadside Safety Facility, University of Nebraska-Lincoln, Lincoln, Nebraska, December 21, 2010.
33. Rosenbaugh, S.K., Schrum, K.D., Faller, R.K., Lechtenberg, K.A., Sicking, D.L., and Reid, J.D., *Development of Alternative Wood-Post MGS Approach Guardrail Transition*, Research Report No. TRP-03-243-11, Final Report to the Midwest States Regional Pooled Fund Program, Project No. TPF-5(193)-Year 19, Project Code RPPF-09-03, Midwest Roadside Safety Facility, University of Nebraska-Lincoln, Lincoln, Nebraska, November 28, 2011.
34. Winkelbauer, B.J., Putjenter, J.G., Rosenbaugh, S.K., Lechtenberg, K.A., Bielenberg, R.W., and Faller, R.K., *Dynamic Evaluation of MGS Stiffness Transition with Curb*, Research Report No. TRP-03-291-14, Final Report to the Midwest States Regional Pooled Fund Program, Project No. TPF-5(193)-Years 23 and 24, Project Code RPPF-13-AGT-1 and 14-AGT-1, Midwest Roadside Safety Facility, University of Nebraska-Lincoln, Lincoln, Nebraska, June 30, 2014.

35. Polivka, K.A., Faller, R.K., Sicking, D.L., Rohde, J.R., Bielenberg, R.W., and Reid, J.D., *Performance Evaluation of the Modified G4(1S) Guardrail – Updated to NCHRP 350 Test No. 3-11 with 28” C.G. Height (2214WB-2)*, Final Report to the National Cooperative Highway Research Program, Project No. NCHRP 22-14(2), Research Report No. TRP-03-169-06, Midwest Roadside Safety Facility, University of Nebraska-Lincoln, Lincoln, Nebraska, October 9, 2006.

9 APPENDICES

Appendix A. Material Specifications, Test No. MGSS-1

Description	Material Specification	Reference
W6x8.5 [W152x12.6], 72" Long [1829] Steel Post	ASTM A992 Min. 50 ksi [345 MPa] Steel Galv. or W6x9 [W152x13.4] ASTM A36 Min. 36 ksi [248 MPa] Steel Galv.	H#55028671 R#14-0097 Red Paint
6x12x14 1/4" [152x305x362] Timber Blockout for Steel Posts	SYP Grade No.1 or better	CWNP Invoice: 43270 Charge# 335 Blue Paint
16D Double Head Nail	-	n/a
12'-6" [3810] W-Beam MGS Section	12 gauge [2.7] AASHTO M180 Galv.	H#4614 AND H#3390
6'-3" [1905] W-Beam MGS Section	12 gauge [2.7] AASHTO M180 Galv.	Red Paint R# 12-0368 "WB2" H# 515691
12'-6" [3810] W-Beam MGS End Section	12 gauge [2.7] AASHTO M180 Galv.	H# 4614
BCT Timber Post - MGS Height	SYP Grade No. 1 or better (No knots, 18" [457] above or below ground tension face)	Green Paint
72" [1829] Long Foundation Tube	ASTM A500 Grade B Galv.	H# Y85912 R# 090453-7
Strut and Yoke Assembly	ASTM A36 Steel Galv.	Req# 090453-8
BCT Cable Anchor Assembly	3/4" [19] 6x19 IWRC IPS Galvanized Wire Rope	Green Paint
Anchor Bracket Assembly	ASTM A36 Steel Galv.	H# V911470 "A2" Black Paint
8"x8"x5/8" [203x203x16] Anchor Bearing Plate	ASTM A36 Steel Galv.	H#6106195 R#090453-9
2 3/8" [60] O.D. x 6" Long [152] BCT Post Sleeve	ASTM A53 Grade B Schedule 40 Galv.	H# 280636 R# 09-0458
5/8" [16] Dia. UNC, 14" [356] Long Guardrail Bolt and Nut Bolt	ASTM A307 Galv., Nut ASTM A563 A Galv.	H# 6600679 Yellow Paint/ L# 22191 R# 12-0368 Red Paint/ L# 22191 R# 12-0348 Blue Paint
5/8" [16] Dia. UNC, 1 1/4" [32] Guardrail Bolt and Nut Bolt	ASTM A307 Galv., Nut ASTM A563 A Galv.	BOLT: H#20206310 R#13-0029 NUT: H#20207480_R#13-0029
5/8" [16] Dia. UNC, 10" [254] Long Guardrail Bolt and Nut Bolt	ASTM A307 Galv., Nut ASTM A563 A Galv.	L#130809L R#14-0207 Green Paint
5/8" [16] Dia. UNC, 1 1/4" [38] Long Hex Head Bolt and Nut Bolt	ASTM A307 Galv., Nut ASTM A563 A Galv.	H#C1007000023 LOT#JW1101045 Rollform Supply
5/8" [16] Dia. UNC, 10" [254] Long Hex Head Bolt and Nut Bolt	ASTM A307 Galv., Nut ASTM A563 A Galv.	Blue Paint R#12-0098 H#780337
7/8" [22] Dia. UNC, 8" [203] Long Hex Head Bolt and Nut Bolt	ASTM A307 Grade A Galv., Nut ASTM A563 A Galv.	R# 12-0037 BOLT: H# 04-3280n NUT: L# 1N1030101 H# 10100058-3
5/8" [16] Dia. Plain Round Washer	ASTM F844 Galv.	Yellow Paint H# 09420734
7/8" [22] Dia. Plain Round Washer	ASTM F844 Galv.	R# 12-0037 H#82800072 L#HO1788740 (HILLMAN COC)

Figure A-1. Bill of Materials, Test No. MGSS-1



US-ML-CARTERSVILLE
384 OLD GRASSDALE ROAD NE
CARTERSVILLE, GA 30121
USA

CERTIFIED MATERIAL TEST REPORT

CUSTOMER SHIP TO HIGHWAY SAFETY CORP 473 W FAIRGROUND ST MARION, OH 43302-1701 USA		CUSTOMER BILL TO HIGHWAY SAFETY CORP GLASTONBURY, CT 06033-0358 USA		GRADE A992/A709-36	SHAPE / SIZE Wide Flange Beam / 6 X 8.5#	
SALES ORDER 448220/000020		CUSTOMER MATERIAL N°		LENGTH 42'00"	WEIGHT 37,485 LB	HEAT / BATCH S8028671/02
SPECIFICATION / DATE or REVISION 1-ASTM A6/A6M-11 2-A992/A992M-11 3-A709/A709M-11 4-A36/A36M-08		CUSTOMER PURCHASE ORDER NUMBER 001562143 IB-B0600800		BILL OF LADING 1323-0000008317	DATE 07/17/2013	

CHEMICAL COMPOSITION													
C %	Mn %	P %	S %	Si %	Cu %	Ni %	Cr %	Mo %	V %	Nb %	N %	Pb %	
0.14	0.50	0.015	0.020	0.19	0.29	0.10	0.07	0.034	0.016	0.002	0.0050	0.0080	

CHEMICAL COMPOSITION	
Sn %	0.012

MECHANICAL PROPERTIES						
Elong %	G/L (req)	UTS (req)	UTS (MPa)	YS 0.2% (req)	YS (MPa)	
20.20	8.000	74300	512	50900	351	
22.10	8.000	74000	510	54800	378	

COMMENTS / NOTES

79

The above figures are certified chemical and physical test records as contained in the permanent records of company. This material, including the billets, was melted and manufactured in the USA. CMTR complies with EN 10204 3.1.

Mhaskar BHASKAR YALAMANCHILI
QUALITY DIRECTOR

YAN WANG
QUALITY ASSURANCE MGR.

Figure A-2. Steel Posts, Test No. MGSS-1



P. O. Box 630 • Sutton, NE 68979
 Phone 402-773-4319
 FAX 402-773-4513

CWNP Invoice 43270
 Shipped To Midwest Marketing
 Customer PO 2589-2

Central Nebraska Wood Preservers, Inc.
 Certification of Inspection

Date: 5/8/12

Specifications: Highway Construction Use

Preservative: CCA - C 0.60 pcf

Charge #	Date Treated	Grade	Material Size, Length & Dressing	# Pieces	White Moisture Readings	Penetration # of Borings & % Conforming	Actual Retentions % Conforming
335	5/3/12	MFA #1	6x12-14" Rght	732	18%	3/0 90%	.607 pcf
334	4/20/12	MFA #1	6x12-19" Adpt. Rght	36	17%	1/0 95%	.623 pcf
332	4/19/12	MFA #1	6x12-19" Rght	176	19%	3/0 85%	.610 pcf

Number of pieces rejected and reason for rejection:
None

Statement: The above reference material was treated and inspected in accordance with the above referenced specifications.

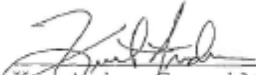
 Kurt Andres, General Manager

5/8/12
 Date

Figure A-3. Wood Blockouts, Test No. MGSS-1



Figure A-4. 16D Double Head Nail, Test No. MGSS-1

GREGORY HIGHWAY PRODUCTS, INC.
 4100 13th St. P.O. Box 80508
 Canton, Ohio 44708

RECEIVED
 OCT 05 2005
 UNL FMP

03/09/2009 14:21 4024722022

Customer: UNIVERSITY OF NEBRASKA-LINCOLN
 401 CANFIELD ADMIN BLDG
 P O BOX 680439
 LINCOLN, NE. 68588-0439

Test Report
 B.O.L. # 15808 DATE SHIPPED: 09/27/05
 Customer P.O.: VERBAL JOHN ROHDE
 Shipped to: UNIVERSITY OF NEBRASKA-LINCOLN
 Project: STOCK
 GHP Order No.: 44822

HEAT #	C.	Mn.	P.	S.	SI.	Tensile	Yield	Elong.	Quantity	Class	Type	Description
3390	0.21	0.8	0.013	0.007	0.01	81680	62520	20.76	100		2	12GA 12FT6IN/3FT1 1/2IN WB T2

82

MWRSF

Bolts comply with ASTM A-307 specifications and are galvanized in accordance with ASTM A-153, unless otherwise stated.
 Nuts comply with ASTM A-563 specifications and are galvanized in accordance with ASTM A-153, unless otherwise stated.
 All other galvanized material conforms with ASTM-123 & ASTM-526
 All steel used in the manufacture is of Domestic Origin, Made and Milled in the United States
 All Guardrail and Terminal Sections meets AASHTO M-163. All structural steel meets AASHTO M-163 & M270
 All Bolts and Nuts are of Domestic Origin

By: 
 Andrew Arar
 Vice President of Sales and Marketing
 Gregory Highway Products, Inc.

RECEIVED
 UNL ACCOUNTING
 OCT - 3 2005

STATE OF OHIO: COUNTY OF STARK
 Sworn to and subscribed before me, a Notary Public, by
 Andrew Arar this 28th day of September, 2005

 Dawn R. Bailton
 Notary Public, State of Ohio
 My Commission Expires February 24, 2008

PAGE 01

Figure A-5. MGS W-Beam 12-ft – 6-in. (3.8-m) Section, Test No. MGSS-1

GREGORY HIGHWAY PRODUCTS, INC.
4100 13th St. P.O. Box 80508
Canton, Ohio 44708

Customer: *UNIVERSITY OF NEBRASKA-LINCOLN
401 CANFIELD ADMIN BLDG
P O BOX 880439
LINCOLN, NE, 68588-0439

Test Report
B.O.L. # 39963
Customer P.O. 4500204081/ 04/06/2009
Shipped to: UNIVERSITY OF NEBRASKA-LINCOLN
Project : TEST PANELS
GHP Order No 105271

DATE SHIPPED: 05/07/09
MAY 14 2009

HT # code	C.	Mn.	P.	S.	Si.	Tensile	Yield	Elong.	Quantity	Class	Type	Description
4614	0.21	0.84	0.011	0.003	0.03	89432	67993	19.8	160	A	2	12GA 12FT6IN/3FT1 1/2IN WB T2

Bolts comply with ASTM A-307 specifications and are galvanized in accordance with ASTM A-153, unless otherwise stated.
 Nuts comply with ASTM A-563 specifications and are galvanized in accordance with ASTM A-153, unless otherwise stated.
 All other galvanized material conforms with ASTM-123 & ASTM-525
 All steel used in the manufacture is of Domestic Origin, "Made and Melted in the United States"
 All Guardrail and Terminal Sections meets AASHTO M-180, All structural steel meets AASHTO M-183 & M270
 All Bolts and Nuts are of Domestic Origin
 All material fabricated in accordance with Nebraska Department of Transportation
 All controlled oxidized/corrosion resistant Guardrail and terminal sections meet ASTM A606, Type 4.

By: Andrew Artar
Andrew Artar
Vice President of Sales & Marketing
Gregory Highway Products, Inc.

STATE OF OHIO: COUNTY OF STARK
Sworn to and subscribed before me, a Notary Public, by
Andrew Artar this 8th day of May, 2009.
Cynthia K Crawford
Notary Public, State of Ohio

 CYNTHIA K. CRAWFORD
Notary Public, State of Ohio
My Commission Expires 09-16-2012

Figure A-6. MGS W-Beam 12-ft – 6-in. (3.8-m) Section, Test No. MGSS-1

Certified Analysis



Trinity Highway Products, LLC

550 East Robb Ave.

Lima, OH 45801

Customer: MIDWEST MACH.& SUPPLY CO.

P. O. BOX 703

MILFORD, NE 68405

Project: RESALE

Order Number: 1164746

Customer PO: 2563

BOL Number: 69500

Document #: 1

Shipped To: NE

Use State: KS

As of: 5/16/12

84

Qty	Part #	Description	Spec	CL	TY	Heat Code/ Heat #	Yield	TS	Elg	C	Mn	P	S	Si	Cu	Cb	Cr	Va	ACW
50	6G	12/6'3/S	M-180	A	2	515691	64,000	72,300	27.0	0.060	0.740	0.009	0.008	0.010	0.021	0.04	0.032	0.000	4
			M-180	A	2	4111321	63,100	80,200	29.0	0.210	0.710	0.009	0.007	0.010	0.030	0.000	0.030	0.000	4
			M-180	A	2	515659	67,000	75,200	26.0	0.064	0.790	0.012	0.008	0.008	0.022	0.000	0.025	0.000	4
			M-180	A	2	515660	66,800	74,300	27.0	0.064	0.740	0.012	0.006	0.009	0.017	0.000	0.025	0.000	4
			M-180	A	2	515662	63,900	72,900	28.0	0.064	0.770	0.010	0.006	0.009	0.016	0.000	0.025	0.000	4
			M-180	A	2	515663	64,900	76,500	21.0	0.064	0.740	0.009	0.007	0.007	0.023	0.000	0.026	0.000	4
			M-180	A	2	515668	66,700	75,500	27.0	0.063	0.770	0.014	0.007	0.010	0.024	0.000	0.030	0.000	4
			M-180	A	2	515668	70,200	80,800	21.0	0.063	0.770	0.014	0.007	0.010	0.024	0.000	0.030	0.000	4
			M-180	A	2	515669	64,500	74,100	26.0	0.063	0.790	0.014	0.007	0.009	0.017	0.000	0.028	0.000	4
			M-180	A	2	515687	63,400	74,100	30.0	0.068	0.750	0.012	0.010	0.008	0.025	0.000	0.060	0.000	4
			M-180	A	2	515687	65,100	74,400	28.0	0.068	0.750	0.012	0.010	0.008	0.025	0.000	0.060	0.000	4
			M-180	A	2	515690	63,000	71,800	27.0	0.059	0.720	0.010	0.008	0.013	0.024	0.000	0.042	0.000	4
			M-180	A	2	515696	62,900	72,500	28.0	0.058	0.740	0.013	0.008	0.011	0.029	0.000	0.046	0.000	4
			M-180	A	2	515696	63,900	73,400	29.0	0.058	0.740	0.013	0.008	0.011	0.029	0.000	0.046	0.000	4
			M-180	A	2	515700	67,800	77,700	28.0	0.065	0.800	0.013	0.009	0.012	0.036	0.000	0.035	0.000	4
			M-180	A	2	616068	62,900	71,600	27.0	0.061	0.740	0.013	0.010	0.012	0.027	0.000	0.064	0.000	4
			M-180	A	2	616068	66,700	74,200	30.0	0.061	0.740	0.013	0.010	0.012	0.027	0.000	0.064	0.000	4
			M-180	A	2	616071	64,000	74,000	28.0	0.061	0.760	0.016	0.007	0.011	0.021	0.000	0.028	0.000	4
			M-180	A	2	616072	63,800	74,200	29.0	0.066	0.750	0.014	0.009	0.010	0.026	0.000	0.039	0.000	4
			M-180	A	2	616073	63,900	73,300	27.0	0.064	0.760	0.016	0.009	0.012	0.024	0.000	0.041	0.000	4
			M-180	A	2	616073	65,000	74,500	28.0	0.064	0.760	0.016	0.009	0.012	0.024	0.000	0.041	0.000	4
30	60G	12/25/6'3/S	M-180	A	2	4111321	63,100	80,200	29.0	0.210	0.710	0.009	0.007	0.010	0.030	0.00	0.030	0.000	4
			M-180	A	2	515656	63,600	73,600	27.0	0.066	0.720	0.012	0.006	0.011	0.021	0.000	0.026	0.000	4
			M-180	A	2	515658	64,800	74,300	26.0	0.069	0.740	0.010	0.006	0.011	0.022	0.000	0.021	0.000	4
			M-180	A	2	515659	67,000	75,200	26.0	0.064	0.790	0.012	0.008	0.008	0.022	0.000	0.025	0.000	4
			M-180	A	2	515663	64,900	76,500	21.0	0.064	0.740	0.009	0.007	0.007	0.023	0.000	0.026	0.000	4

1 of 4

Figure A-7. MGS W-Beam 6-ft – 3-in. (1.9-m) Section, Test No. MGSS-1

GREGORY HIGHWAY PRODUCTS, INC.
4100 13th St. P.O. Box 80508
Canton, Ohio 44708

Customer: UNIVERSITY OF NEBRASKA-LINCOLN
401 CANFIELD ADMIN BLDG
P O BOX 890439
LINCOLN, NE. 68588-0439

Test Report
B.O.L. # 39963
Customer P.O. 4500204081/ 04/06/2009
Shipped to: UNIVERSITY OF NEBRASKA-LINCOLN
Project: TEST PANELS
GHP Order No 105271

DATE SHIPPED: 05/07/09

RECEIVED
MAY 14 2009
UNL ACCOUNTS

HT # code	C.	Mn.	P.	S.	SI.	Tensile	Yield	Elong.	Quantity	Class	Type	Description
4614	0.21	0.84	0.011	0.003	0.03	89432	67983	19.8	160	A	2	12GA 12FT6IN/3FT1 1/2IN WB T2

Bolts comply with ASTM A-307 specifications and are galvanized in accordance with ASTM A-153, unless otherwise stated.
Nuts comply with ASTM A-563 specifications and are galvanized in accordance with ASTM A-153, unless otherwise stated.
All other galvanized material conforms with ASTM-123 & ASTM-525
All steel used in the manufacture is of Domestic Origin. "Made and Malted in the United States"
All Guardrail and Terminal Sections meets AASHTO M-180. All structural steel meets AASHTO M-183 & M270
All Bolts and Nuts are of Domestic Origin
All material fabricated in accordance with Nebraska Department of Transportation
All controlled oxidized/corrosion resistant Guardrail and terminal sections meet ASTM A606, Type 4.

By: Andrew Artar
Andrew Artar
Vice President of Sales & Marketing
Gregory Highway Products, Inc.

STATE OF OHIO: COUNTY OF STARK
Sworn to and subscribed before me, a Notary Public, by
Andrew Artar this 8th day of May, 2009.
Cynthia K Crawford
Notary Public, State of Ohio



CYNTHIA K. CRAWFORD
Notary Public, State of Ohio
My Commission Expires 09-16-2012

Figure A-8. MGS W-Beam End Section, Test No. MGSS-1



CWNP
CENTRAL
NEBRASKA
WOOD PRESERVERS, INC.

P. O. Box 630 • Sutton, NE 68979
Phone 402-773-4319
FAX 402-773-4513

CWNP Invoice 46258

Shipped To Midwest Machine, Mfg Co

Customer PO 2751

Central Nebraska Wood Preservers, Inc.
Certification of Inspection

Date: 5/10/13 Ks.

Specifications: Highway Construction Use

Preservative: CCA - C 0.60 pcf

Charge #	Date Treated	Grade	Material Size, Length & Dressing	# Pieces	White Moisture Readings	Penetration # of Borings & % Conforming	Actual Retentions % Conforming
431	4/26/13	MPG #1	6x8-6.5' S4S	210	18%	2/0 90%	.647 pct
431	4/26/13	MPG #1	6x8-23" S4S	96	18%	2/0 90%	.647 pct
433	5/2/13	MPG #1	6x8-14" S4S	75	17%	1/0 95%	.618 pct
433	5/2/13	MPG #1	6x8-46" S4S	48	17%	1/0 95%	.618 pct
433	5/2/13	MPG #1	6x8-19" Pgt	60	17%	1/0 95%	.618 pct

Number of pieces rejected and reason for rejection:
None

Statement: The above reference material was treated and inspected in accordance with the above referenced specifications.

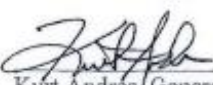

Kurt Andres, General Manager

5/10/13

Date

Figure A-9. BCT Timber Posts, Test No. MGSS-1

Certified Analysis



Trinity Highway Products , LLC
 425 E. O'Connor
 Lima, OH
 Customer: MIDWEST MACH.& SUPPLY CO.
 P. O. BOX 81097
 LINCOLN, NE 68501-1097
 Project: STOCK

Order Number: 1108107
 Customer PO: 2132
 BOL Number: 48341
 Document #: 1
 Shipped To: NE
 Use State: KS

As of: 5/22/09

Qty	Part#	Descriptions	Spec	CL	TY	Heat Code/ Heat #	Yield	TS	Elg	C	Min	P	S	SI	Cu	Co	Cr	Vn	ACW
			M-180 A		2	C49037	64,600	88,600	21.2	0.210	0.880	0.010	0.090	0.030	0.080	0.000	0.060	0.010	4
25	736G	5/TUBE SL/180"X6"X8"FLA	A-500			Y85912	56,500	72,980	37.0	0.210	0.770	0.009	0.006	0.016	0.010	0.00	0.020	0.001	4
6	742G	60 TUBE SL/180X8X6	A-500			Y85912	56,500	72,980	37.0	0.210	0.770	0.009	0.006	0.016	0.010	0.00	0.020	0.001	4
26	764G	1/4"X24"X24"SOIL PLATE	A-36			120039	46,660	73,630	26.9	0.190	0.520	0.012	0.003	0.020	0.090	0.00	0.040	0.000	4
12	923G	BRONSTAD 98" W/O	M-180 A		2	122209	63,590	82,010	26.6	0.190	0.720	0.015	0.004	0.020	0.110	0.00	0.040	0.000	4
4	927G	10"END SHOE/EXT	M-180 B		2	A814375	59,770	78,641	27.4	0.210	0.750	0.017	0.005	0.030	0.090	0.00	0.030	0.002	4

Upon delivery, all materials subject to Trinity Highway Products , LLC Storage Stain Policy No. LG-002.

ALL STEEL USED WAS MELTED AND MANUFACTURED IN USA AND COMPLIES WITH THE BUY AMERICA ACT.

ALL GUARDRAIL MEETS AASHTO M-180, ALL STRUCTURAL STEEL MEETS ASTM A36

ALL GALVANIZED MATERIAL CONFORMS WITH ASTM-123, UNLESS OTHERWISE STATED.

BOLTS COMPLY WITH ASTM A-307 SPECIFICATIONS AND ARE GALVANIZED IN ACCORDANCE WITH ASTM A-153, UNLESS OTHERWISE STATED.

NUTS COMPLY WITH ASTM A-563 SPECIFICATIONS AND ARE GALVANIZED IN ACCORDANCE WITH ASTM A-153, UNLESS OTHERWISE STATED.

3/4" DIA CABLE 6X19 ZINC COATED SWAGED END AISI C-1035 STEEL ANNEALED STUD 1" DIA ASTM 449 AASHTO M30, TYPE II BREAKING STRENGTH - 49100 LB

State of Ohio, County of Allen. Sworn and subscribed before me this 22nd day of May, 2009

Notary Public: *Sean G. Hartline*
 Commission Expires 11 28 2012

Trinity Highway Products , LLC

Certified By: *[Signature]*
 Quality Assurance

Figure A-10. Foundation Tubes, Test No. MGSS-1

425 E. O'Connor
Lima, OH



Customer: MIDWEST MACH. & SUPPLY CO.
P. O. BOX 81097

Sales Order: 1093497
Customer PO: 2030
BOL # 43073
Document # 1

Print Date: 6/30/08
Project: RESALE
Shipped To: NE
Use State: KS

LINCOLN, NE 68501-1097

Trinity Highway Products, LLC

Certificate Of Compliance For Trinity Industries, Inc. ** SLOTTED RAIL TERMINAL **

NCHRP Report 350 Compliant

Pieces	Description
64	5/8"X10" GR BOLT A307
192	5/8"X18" GR BOLT A307
32	1" ROUND WASHER F844
64	1" HEX NUT A563
192	WD 60 POST 6X8 CRT
192	WD BLK 6X8X14 DR
64	NAIL 16d SRT
64	WD 3'9 POST 5.5X7.5 BAND
32	STRUT & YOKE ASSY
128	SLOT GUARD '98
32	3/8 X 3 X 4 PL WASHER

MGSSBR

Ground Strut

090453-8

Upon delivery, all materials subject to Trinity Highway Products, LLC Storage Stain Policy No. LG-002.

ALL STEEL USED WAS MELTED AND MANUFACTURED IN USA AND COMPLIES WITH THE BUY AMERICA ACT

ALL GUARDRAIL MEETS AASHTO M-180, ALL STRUCTURAL STEEL MEETS ASTM A36

ALL OTHER GALVANIZED MATERIAL CONFORMS WITH ASTM-123.

BOLTS COMPLY WITH ASTM A-307 SPECIFICATIONS AND ARE GALVANIZED IN ACCORDANCE WITH ASTM A-153, UNLESS OTHERWISE STATED.

NUTS COMPLY WITH ASTM A-563 SPECIFICATIONS AND ARE GALVANIZED IN ACCORDANCE WITH ASTM A-153, UNLESS OTHERWISE STATED.

4" DIA CABLE 6X19 ZINC COATED SWAGED END AISI C-1035 STEEL ANNEALED STUD 1" DIA ASTM 449 AASHTO M30, TYPE II BREAKING

TRENGTH - 49100 LB

(State of Ohio, County of Allen. Sworn and Subscribed before me this 30th day of June, 2008

Notary Public:

Commission Expires:

Wanda Smith
Wanda Smith
Notary Public
June 30, 2012

Trinity Highway Products, LLC

Certified By:

Angie Lamb

2 of 4

88

Figure A-11. Strut and Yoke Assembly, Test No. MGSS-1

Certified Analysis



Trinity Highway Products, LLC
 550 East Robb Ave.
 Lima, OH 45801

Order Number: 1145215

Customer PO: 2441

As of: 4/15/11

Customer: MIDWEST MACH.& SUPPLY CO.
 P. O. BOX 703

BOL Number: 61905

Document #: 1

Shipped To: NE

MILFORD, NE 68405

Use State: KS

Project: RESALE

Qty	Part #	Description	Spec	CL	TY	Heat Code/Heat #	Yield	TS	Elg	C	Mn	P	S	Si	Cu	Ch	Cr	Vn	ACW
10	206G	T12/6'3/S	M-180	A	2	140734	64,240	82,640	26.4	0.190	0.740	0.015	0.006	0.010	0.110	0.00	0.060	0.000	4
			M-180	A	2	139587	64,220	81,750	28.5	0.190	0.720	0.014	0.003	0.020	0.130	0.000	0.060	0.002	4
			M-180	A	2	139588	63,850	82,080	24.9	0.200	0.730	0.012	0.004	0.020	0.140	0.000	0.050	0.002	4
			M-180	A	2	139589	55,670	74,810	27.7	0.190	0.720	0.012	0.003	0.020	0.130	0.000	0.060	0.002	4
			M-180	A	2	140733	59,000	78,200	28.1	0.190	0.740	0.015	0.006	0.010	0.120	0.000	0.070	0.001	4
55	260G	T12/25/6'3/S	M-180	A	2	139588	63,850	82,080	24.9	0.200	0.730	0.012	0.004	0.020	0.140	0.00	0.050	0.002	4
			M-180	A	2	139206	61,730	78,580	26.0	0.180	0.710	0.012	0.004	0.020	0.140	0.000	0.050	0.001	4
			M-180	A	2	139587	64,220	81,750	28.5	0.190	0.720	0.014	0.003	0.020	0.130	0.000	0.060	0.002	4
			M-180	A	2	140733	59,000	78,200	28.1	0.190	0.740	0.015	0.006	0.010	0.120	0.000	0.070	0.001	4
			M-180	A	2	140734	64,240	82,640	26.4	0.190	0.740	0.015	0.006	0.010	0.110	0.000	0.060	0.000	4
			M-180	A	2	140734	64,240	82,640	26.4	0.190	0.740	0.015	0.006	0.010	0.110	0.00	0.060	0.000	4
			M-180	A	2	139587	64,220	81,750	28.5	0.190	0.720	0.014	0.003	0.020	0.130	0.000	0.060	0.002	4
			M-180	A	2	139588	63,850	82,080	24.9	0.200	0.730	0.012	0.004	0.020	0.140	0.000	0.050	0.002	4
			M-180	A	2	139589	55,670	74,810	27.7	0.190	0.720	0.012	0.003	0.020	0.130	0.000	0.060	0.002	4
			M-180	A	2	140733	59,000	78,200	28.1	0.190	0.740	0.015	0.006	0.010	0.120	0.000	0.070	0.001	4
26	701A	.25X11.75X16 CAB ANC	A-36			V911470	51,460	71,280	27.5	0.120	0.800	0.015	0.030	0.190	0.300	0.00	0.090	0.023	4
			A-36			N3540A	46,200	65,000	31.0	0.120	0.380	0.010	0.019	0.010	0.180	0.00	0.070	0.001	4
24	729G	TS 8X6X3/16X8'-0" SLEEVE	A-500			N4747	63,548	85,106	27.0	0.150	0.610	0.013	0.001	0.040	0.160	0.00	0.160	0.004	4
24	749G	TS 8X6X3/16X6'-0" SLEEVE	A-500			N4747	63,548	85,106	27.0	0.150	0.610	0.013	0.001	0.040	0.160	0.00	0.160	0.004	4
22	782G	5/8"X8"X8" BEAR PL/OF	A-36			18486	49,000	78,000	25.1	0.210	0.860	0.021	0.035	0.250	0.260	0.00	0.170	0.014	4
25	974G	T12/TRANS RAIL/6'3"/3'1.5	M-180	A	2	140735	61,390	80,240	27.1	0.200	0.740	0.014	0.005	0.010	0.120	0.00	0.070	0.001	4

89

Figure A-12. Anchor Bracket Assembly, Test No. MGSS-1

Certified Analysis



Trinity Highway Products, LLC
 2548 N.E. 28th St.
 Ft Worth, TX
 Customer: MIDWEST MACH. SUPPLY CO.
 P. O. BOX 81097
 LINCOLN, NE 68501-1097
 Project: RESALE

Order Number: 1095199
 Customer PO: 2041
 BOL Number: 24481
 Document #: 1
 Shipped To: NE
 Use State: KS

As of: 6/20/08

Qty	Part#	Description	Spec	CL	TY	Heat Code/ Heat#	Yield	TS	Elg	C	Min	P	S	SI	Cu	Co	Cr	Vn	ACW
25	6G	12/63/8	M-180	A		84864	64,230	81,300	25.4	0.180	0.720	0.012	0.001	0.040	0.080	0.060	0.060	0.000	4
20	701A	.25X11.75X16 CAB ANC	A-36			4153095	44,900	60,800	34.0	0.240	0.750	0.012	0.003	0.020	0.020	0.000	0.040	0.002	4
10	742G	60 TUBE SL/188X8X6	A-500			A8P1160	74,000	87,000	25.2	0.050	0.670	0.013	0.005	0.030	0.220	0.000	0.060	0.021	4
20	782G	5/8"X8"X8" BEAR PLOF	A-36			6106195	46,700	69,900	23.5	0.180	0.830	0.010	0.005	0.020	0.230	0.000	0.070	0.006	4
40	907G	12/BUFFER/ROLLED	M-180	A		L0049	54,200	73,500	25.0	0.160	0.700	0.011	0.008	0.020	0.200	0.000	0.100	0.000	4

Upon delivery, all materials subject to Trinity Highway Products, LLC Storage Stain Policy No. LG-002.

ALL STEEL USED WAS MELTED AND MANUFACTURED IN USA AND COMPLIES WITH THE BUY AMERICA ACT.

ALL GUARDRAIL BEETS AASHTO M-180, ALL STRUCTURAL STEEL BEETS ASTM A36

ALL OTHER GALVANIZED MATERIAL CONFORMS WITH ASTM-123.

BOLTS COMPLY WITH ASTM A-307 SPECIFICATIONS AND ARE GALVANIZED IN ACCORDANCE WITH ASTM A-153, UNLESS OTHERWISE STATED.

NUTS COMPLY WITH ASTM A-563 SPECIFICATIONS AND ARE GALVANIZED IN ACCORDANCE WITH ASTM A-153, UNLESS OTHERWISE STATED.

3/8" DIA CABLE 6X19 ZINC COATED SWAGED END AISI C-1035 STEEL ANNEALED STUD 1" DIA ASTM 449 AASHTO M30, TYPE II BREAKING STRENGTH - 49100 LB

State of Texas, County of Tarrant. Sworn and subscribed before me this 20th day of June, 2008

Notary Public:
Commission Expires

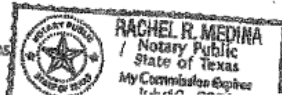

Trinity Highway Products, LLC
Certified By:

Stefanie Amala

Figure A-13. Anchor Bearing Plate, Test No. MGSS-1



906 ATLANTIC STREET, NORTH KANSAS CITY, MO 64118 1-816-474-8210 TOLL FREE 1-800-892-TUBE

STEEL VENTURES, LLC dba EXLTUBE

CERTIFIED TEST REPORT

Customer: SPS - New Century 401 New Century Parkway New Century KS 69031	Size:	Spec No:	Date:
	02.375	ASTM A500-07, A53E-07	05/22/2008
	Grade:	Grade:	Customer Order No:
	.154	A500B,C, A53BNT	4500104158
			St. No:
			87162893

Heat No	Yield P.S.I.	Tensile P.S.I.	Elongation % 2 inch
280638	61,500	86,400	23.00

*SAFE JB MAT
CRT*

Heat No	C	MN	P	S	SI	CU	NI	CR	MO	V
280638	0.040	0.330	0.010	0.000	0.034	0.088	0.039	0.042	0.015	0.003

We hereby certify that the above material was manufactured in the U.S.A and that all test results shown in this report are correct as contained in the records of our company. All testing and manufacturing is in accordance to A.S.T.M. parameters encompassed within the scope of the specifications denoted in the specification and grade titles above.

BNT - Grade B not tested - meets tensile properties ONLY.

STEEL VENTURES, LLC dba EXLTUBE

Steve Frerichs
Quality Assurance Manager

104158

Figure A-14. BCT Post Sleeve, Test No. MGSS-1

FASTENERS & FITTINGS INC.

901 STEELES AVENUE EAST
MILTON, ONTARIO L9T 5H3
PHONE: (905) 670-2503 FAX: (905) 670-2506, TOLL FREE: 1-800-613-4094

**ISO 9001
REGISTERED COMPANY**

CERTIFICATE OF CONFORMANCE

CUSTOMER	: ROLL FORM GROUP	OUR PACKING SLIP NO:	: 66192
CUSTOMER PO NO	: 18329	OUR INVOICE NO:	: ---
ITEM	: GUARDRAIL BOLT	SUPPLIER INVOICE NO	: HSW07046
SIZE	: 5/8" - 11 x 14" H.D.G	BULK LOT NO / PO No.	: 1017
HEAT NO	: 6600679	DATE	: 12-Jun-07

No	Test Item	Specs / Standards / Criteria	Result
1	Appearance	Per ASTM F 812-95	OK
2	Thread	Go & No Go and P.D & M.D	OK
3	Mark		307 A N
4	Coating Thickness	CSA-CSAG-164-M Class 5 (Min 65um or 2.54 mills) Avg.	70.8
5	Mass of Coating	CSA-CSAG-164-M Class 5 (Min 480g/m2 or 1.5 oz/ft2) Avg.	505.3
6	Dimensions	Head Diameter(31.80-34.85)	32.36-33.51
		Head Height(7.20-10.26)	8.62-9.39
		Shoulder Width O(22.25-23.77)	22.68-23.21
		Shoulder Width V(15.08-16.66)	15.76-16.33
		Shoulder Depth P(4.78-6.29)	5.61-6.01
		Length(351.03-359.15)	353.77-355.20
7	Tensile Strength	Min 60,000 PSI	61,500-64,000 PSI
8	Material	Per ASTM (A307)	OK

Material Chemical Composition:

C	Si	Mn	P	S
%	%	%	%	%
0.12	0.18	0.46	0.028	0.02

Hot Dip Galvanizing Inspection Certificate: (Test Standard CSAG-164-M class 5)

Test of No.	Weight of coating test							G/m ² over
1	70	73	70	69	72	72	71.0	506.9
2	72	68	72	72	68	72	70.7	504.6
3	69	72	70	68	72	72	70.5	503.4
4	71	70	71	72	69	71	70.7	504.6
5	72	70	72	72	71	69	71.0	506.9
Average of The Average							70.8	505.3

Muhammad Ashraf
905-670-2503 ext 328
16 Aug 2011

2-0063-11X1400*SGUG (HSW07046) WO# 11165 PPS# 66192 CustPO# 18329 Aug16-2011

Figure A-15. 5/8 in. Dia. UNC, 14 in. Long Guardrail Bolt, Test No. MGSS-1

3540G

INSPECTION CERTIFICATE

ROCKFORD BOLT & STEEL CO.
126 MILL STREET
ROCKFORD, IL 61101
815-968-0514 FAX# 815-968-3111

CUSTOMER NAME: TRINITY INDUSTRIES
CUSTOMER P.O.: 143227
INVOICE #: 946256 **DATE SHIPPED:** 6/20/11
LOT #: 22191
SPECIFICATION: ASTM A307, GRADE A MILD CARBON STEEL BOLTS

TENSILE RESULTS:	SPECIFICATION	ACTUAL		
	80,000 min.	81,480	70,642	76,898
		81,389	70,341	76,623
HARDNESS RESULTS:	SPECIFICATION	80.63	83.90	84.00
	100 MAX	86.33	77.90	85.00

COATING: ASTM SPECIFICATION F2329 HOT DIP GALVANIZE

STEEL SUPPLIER: NUCOR, CHARTER, NUCOR

HEAT NO. NF11101335, 10132120, NF11101336

QUANTITY AND DESCRIPTION:

18,900 PCS 5/8" X 14" GUARD RAIL BOLT
P/N 3540G

WE HEREBY CERTIFY THE ABOVE BOLTS HAVE BEEN MANUFACTURED BY ROCKFORD BOLT AND STEEL. THE MATERIAL USED WAS MELTED AND MANUFACTURED IN THE U.S.A.. WE FURTHER CERTIFY THAT THIS DATA IS A TRUE REPRESENTATION OF INFORMATION PROVIDED BY THE MATERIALS SUPPLIER, AND THAT OUR PROCEDURES FOR THE CONTROL OF PRODUCT QUALITY ASSURE THAT ALL ITEMS FURNISHED ON THIS ORDER MEET OR EXCEED ALL APPLICABLE TESTS, PROCESS, AND INSPECTION REQUIREMENTS PER ABOVE SPECIFICATION.

STATE OF ILLINOIS
COUNTY OF WINNEBAGO

SIGNED BEFORE ME ON THIS 21 DAY OF June 20 11
Diana Rasmussen

Shinda McComas 6/21/11
APPROVED SIGNATORY DATE



Figure A-16. 5/8 in. Dia. UNC, 14 in. Long Guardrail Bolt, Test No. MGSS-1

TRINITY HIGHWAY PRODUCTS, LLC
425 East O'Connor Ave.
Lima, Ohio 45801
419-227-1296

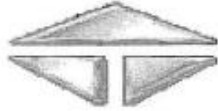

MATERIAL CERTIFICATION

Customer: Stock Date: June 27, 2012
Invoice Number: _____
Lot Number: 1206228
Part Number: 3360G Quantity: 121,092
Description: 5/8" x 1 1/4" GR BOLT Heat Number(s): 20206310

Specification: ASTM A307-A / A153 / F2329

MATERIAL CHEMISTRY

Heat	C	MN	P	S	SI	NI	CR	MO	CU	SN	V	AL	N	B	TI	NB
20206310	.09	.36	.007	.002	.09	.03	.06	.01	.08	.006	.001	.028	.007	.0003	.001	.001

PLATING OR PROTECTIVE COATING

HOT DIP GALVANIZED (Lot Ave.Thickness / Mills) 2.58 (2.0 Mills Minimum)

****THIS PRODUCT WAS MANUFACTURED IN THE UNITED STATES OF AMERICA****

THE MATERIAL USED IN THIS PRODUCT WAS MELTED AND MANUFACTURED IN THE U.S.A
WE HEREBY CERTIFY THAT TO THE BEST OF OUR KNOWLEDGE ALL INFORMATION CONTAINED HEREIN IS CORRECT.

[Signature]

TRINITY HIGHWAY PRODUCTS LLC

STATE OF OHIO, COUNTY OF ALLEN
SWORN AND SUBSCRIBED BEFORE ME THIS 27th DAY OF JUNE, 2012

[Signature] NOTARY PUBLIC

425 E. O'CONNOR AVENUE LIMA, OHIO 45801 419-227-1296

Figure A-17. 5/8 in. Dia. UNC, 1 1/4 in. Guardrail Bolt, Test No. MGSS-1

Trinity

TRINITY HIGHWAY PRODUCTS, LLC
425 East O'Connor Ave.
Lima, Ohio 45801
419-227-1296



MATERIAL CERTIFICATION

Customer: Stock Date: JULY 7, 2012
Invoice Number: _____
Lot Number: 120629N2
Part Number: 3340G Quantity: 108,000
Description: 5/8" GUARD RAIL NUT +.031 Heat Number(s): 20207480
20207490

Specification: ASTM 563-A / A153 / F2329 as described

MATERIAL CHEMISTRY

Heat	C	MN	P	S	SI	NI	CR	MO	CU	SN	V	AL	N	B	TI	NB
20207480	.10	.34	.007	.002	.04	.04	.07	.01	.08	.004	.002	.027	.008	.0002	.001	.001
20207490	.09	.35	.006	.002	.07	.03	.07	.01	.08	.005	.002	.029	.007	.0002	.001	.001

PLATING AND/OR PROTECTIVE COATING

HOT DIP GALVANIZED (Lot Ave. Thickness / Mills) 2.48 (2.0 Mills Minimum)

****THIS PRODUCT WAS MANUFACTURED IN THE UNITED STATES OF AMERICA****

THE MATERIAL USED IN THIS PRODUCT WAS MELTED AND MANUFACTURED IN THE U.S.A

WE HEREBY CERTIFY THAT TO THE BEST OF OUR KNOWLEDGE ALL INFORMATION CONTAINED
HEREIN IS CORRECT

[Signature]

TRINITY HIGHWAY PRODUCTS LLC

STATE OF OHIO, COUNTY OF ALLEN
SWORN AND SUBSCRIBED BEFORE ME THIS 7th DAY OF JULY, 2012
[Signature] NOTARY PUBLIC

425 E. O'CONNOR AVENUE LIMA, OHIO 45801 419-227-1296

Figure A-18. 5/8 in. Dia. UNC, Guardrail Nut, Test No. MGSS-1

5/8x10" post bolt
R#14-0207 Green Paint

8/26/13

3500G

TRINITY HIGHWAY PRODUCTS, LLC
425 East O'Connor Ave.
Lima, Ohio 45801
419-227-1296



MATERIAL CERTIFICATION

Customer: Stock Date: August 16, 2013
Invoice Number: _____
Lot Number: 130809L
Part Number: 3500G Quantity: 16,233 Pcs.
Description: 5/8" x 10" G.R. Bolt Heat Numbers: 10240100 10,820
10231650 5,413

Specification: ASTM A307-A / A153 / F2329

PASSED & CERTIFIED
AUG 20 2013
Trinity Highway Products, LLC
Dallas, Texas Plant 99

MATERIAL CHEMISTRY

Heat	C	MN	P	S	SI	NI	CR	MO	CU	SN	V	AL	N	B	TI	NB
10240100	.09	.49	.01	.007	.09	.04	.09	.02	.08	.008	.002	.023	.005	.0001	.001	.001
10231650	.09	.49	.008	.011	.09	.05	.08	.02	.09	.006	.002	.023	.007	.0001	.001	.001

PLATING OR PROTECTIVE COATING

HOT DIP GALVANIZED (Lot Ave.Thickness / Mills) 2.51 (2.0 Mills Minimum)

*****THIS PRODUCT WAS MANUFACTURED IN THE UNITED STATES OF AMERICA*****

THE MATERIAL USED IN THIS PRODUCT WAS MELTED AND MANUFACTURED IN THE U.S.A
WE HEREBY CERTIFY THAT TO THE BEST OF OUR KNOWLEDGE ALL INFORMATION CONTAINED HEREIN IS
CORRECT.

[Signature]
TRINITY HIGHWAY PRODUCTS LLC

STATE OF OHIO, COUNTY OF ALLEN
SWORN AND SUBSCRIBED BEFORE ME THIS 19th day of Aug
Sharon Braun NOTARY PUBLIC
425 E. O'CONNOR AVENUE LIMA, OHIO 45801



Figure A-19. 5/8 in. Dia. UNC, 10 in. Long Guardrail Bolt, Test No. MGSS-1

Certificate of Compliance

Birmingham Fastener Manufacturing
PO Box 10323
Birmingham, AL 35202
(205) 595-3512

Customer MIDWEST MACHINERY Date Shipped 03/21/2011
Customer Order Number 2430 BFM Order Number 100325-00

Item Description

Description 5/8"-11 x 10" HEX BOLT Qty 100
Lot # 154572 Specification ASTM A307-07b Gr A Finish F2329

Raw Material Analysis

Heat# 780337

Chemical Composition (wt% Heat Analysis) By Material Supplier

C	Mn	P	S	Si	Cu	Ni	Cr	Mo
0.16	0.54	0.009	0.04	0.18	0.36	0.09	0.13	0.020

Mechanical Properties

Sample #	Hardness	Tensile Strength (lbs)	Tensile Strength (psi)
1	80 HRB	16,700	73,900
2	80 HRB	16,600	73,400
3			
4			
5			

This information represents the most recent analysis of the product supplied on the stated customer order. The samples tested conform to the ASTM standard listed above. All steel melted and manufactured in the U.S.A.

Authorized Signature:  Date: 3/21/2011
Brian Hughes
Quality Assurance

Figure A-20. 5/8 in. Dia. UNC, 10 in. Long Hex Head Bolt, Test No. MGSS-1

CERTIFICATE OF CONFORMANCE

DESCRIPTION OF MATERIAL AND SPECIFICATIONS:

• PURCHASE ORDER NUMBER:	44773 000 OD	• INVOICE NO.	GBT11638102
• QUANTITY (Pcs.)	37,600 SETS	LOT NO.	JW1101045
• THE DATE OF MANUFACTURE	March to April ,2011	HEAT NO.	C10070002
• TENSILE STRENGTH:	13,800LBF	HARDNESS.	HRB77-74
• ITEM DESCRIPTION:	5/8-11x1,1/4" GUARDRAIL BOLT CLIP HD W/NUT HDG		
• ITEM NUMBER:	20-2100K		
• TYPE OF STEEL	Q235A(C1010 or C1008)		
• BOLT SPECIFICATION:	ASTM A307		
• NUTS SPECIFICATION:	ASTM A563 GRADE A		
• COATING	ASTM A153 CLASS C		
• APPEARANCE	ASTM F612-95		

THE DATA IN THIS REPORT IS A TRUE REPRESENTATION OF INFORMATION PROVIDED BY THE MATERIAL SUPPLIER CERTIFYING THAT THE PRODUCT MEETS THE MECHANICAL AND MATERIAL REQUIREMENTS OF THE LISTED SPECIFICATION. THIS CERTIFICATE APPLIES TO THE PRODUCT SHOWN ON THIS DOCUMENT,

THIS DOCUMENT MAY ONLY BE REPRODUCED UNALTERED AND ONLY FOR CERTIFYING THE SAME OR LESSER QUANTITY OF THE PRODUCT SPECIFIED HEREIN. REPRODUCTION OR ALTERATION OF THIS DOCUMENT FOR ANY OTHER PURPOSE IS PROHIBITED.

BY: _____

TITLE: _____



Print Date:2011-5-12

Figure A-21. 5/8 in. Dia. UNC, 1 1/4 in. Long Hex Head Bolt, Test No. MGSS-1

**CERTIFIED MATERIAL TEST REPORT
FOR ASTM A307, GRADE A - MACHINE BOLTS**

FACTORY:LIANYUNGANGSHI PINGXIN FASTENER CO.,LTD DATE: 9/Nov/07
ADDRESS:No.3 jingsan Road,Biotechnology Park,Haizhou Bay,Haitou Town,Ganyu County,Lianyungang CHINA
MFG LOT NUMBER: M-NBPX0339-31
CUSTOMER:
PO NUMBER:17071802
SAMPE SIZE: ACC. TO ASME B18 . 18 . 2M - 93 PART NO:00026-3464-451
SIZE: 7/8-9X8 ZP QNTY: 1440 PCS
HEADMARKS: 307A PLUS PX MANU.DATE:

STEEL PROPERTIES: Q235 25mm
STEEL GRADE: HEAT NUMBER: 04-3280n

CHEMISTRY SPEC:	C %*100	Mn%*100	P %*1000	S %*1000
TEST:	0.29max	1.20 max	0.04max	0.05max
	0.15	0.45	0.024	0.033

DIMENSIONAL INSPECTIONS		SPECIFICATION: ASME B18.2.1 - 2010		
CHARACTERISTICS	SPECIFIED	ACTUAL RESULT	ACC.	REJ.
VISUAL	ASTM F788/F788M-08	PASSED	100	0
THREAD	ASME B1.3	PASSED	32	0
WIDTH FLATS	1.269-1.312	1.279-1.302	8	0
WIDTH A/C	1.447-1.516	1.457-1.506	8	0
HEAD HEIGHT	0.531-0.604	0.541-0.584	8	0
BODY DIA.	0.8660-0.8750	0.8677-0.8741	8	0
THREAD LENGTH	2.25	2.28-2.38	8	0
LENGTH	7.80-8.16	7.82-8.14	8	0

MECHANICAL PROPERTIES:		SPECIFICATION: ASTM A307-2010 GR-A			
CHARACTERISTICS	TEST METHOD	SPECIFIED	ACTUAL RESULT	ACC.	REJ.
CORE HARDNESS :	ASTM F606-2010a	69-100 HRB	92-95 HRB	8	0
WEDGE TENSILE:	ASTM F606-2010a	Min 60 KSI	82-85 KSI	4	0
CHARACTERISTICS	TEST METHOD	SPECIFIED	ACTUAL RESULT	ACC.	REJ.
COATINGS OF ZINC	ASTM F1941	Min 4 μm	5 μm	4	0

ALL TESTS IN ACCORDANCE WITH THE METHODS PRESCRIBED IN THE APPLICABLE ASTM SPECIFICATION. WE CERTIFY THAT THIS DATA IS A TRUE REPRESENTATION OF INFORMATION PROVIDED BY THE MATERIAL SUPPLIER AND OUR TESTING LABORATORY.

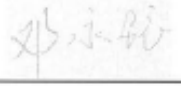

(SIGNATURE OF Q.A. LAB MGR.)
(NAME OF MANUFACTURER)

Figure A-22. 7/8 in. Dia. UNC, 8 in. Long Hex Head Bolt, Test No. MGSS-1



Figure A-23. 7/8 in. Dia. UNC, Hex Head Nut, Test No. MGSS-1

**CERTIFIED MATERIAL TEST REPORT
FOR USS FLAT WASHER**

DATE 2011-4-15
(日期)
INVOICE NO. GBT11538101
PO NUMBER 44773 000 OD
(订单号码)
MFG LOT NUMBER: JW1101045
(工厂生产批号)

SAMPLING PLAN PER ASTM B 18.22.1
(根据ASTM B 18.22.1 抽样检验)
PART NAME: USS FLAT WASHERS
(品名)
SIZE: 5/8" HDG QNTY: 1000 PCS PART NO:
(规格) (数量) (货号)
MARKS: MFG ID: /
(头部标记)

STEEL PROPERTIES: (钢材性质)
STL GRADE: Q235 STEEL SIZE: 4mm x 0mm x 9000 HEAT NO: 09420734
(钢材级别) (钢材规格) (炉号)

CHEMISTRY COMPOSITION:

ELEMENT (成份)	C %	Mn %	P %	S %	SI %	Cr %	NI %	-	-
SPEC: (标准)	Min. 0.14	Max 0.65	Max 0.045	Max 0.050	Max 0.30				
RESULT: (结果)	0.15	0.47	0.021	0.016	0.17			-	-

MECHANICAL PROPERTIES: (机械性能)

	SURFACE HARDNESS (HRC)	PROOF LOAD (LBF)	HARDNESS TEST AFTER HEAT TREATMENT 24HR AT 540°C (HRB)	TEMPERING TEMPERATURE °C
SPEC	/	/	/	/
HIGH	_____	_____	_____	_____
LOW	_____	_____	_____	_____
AVG	_____	_____	_____	_____

ACID MACRO STRUCTURE					MACRO ETCH TESTING
SCATTERED POROSITY	CENTRE UNSOUNDNESS		PATTERN		
0.5	0.5	0.5	0.5	0.5	PASSED

DIMENSION AS PER ANSI B18.2.2
(尺寸依据 ANSI B18.2.2)

	Thickness(mm)	Inside Diameter (内径) mm	Outside Diameter (外径) mm
SPEC: (标准)	4.06-2.74	18.24-17.3	45.21-42.67
RESULT: (检验结果)	3.25-3.07	17.94-17.81	44.96-44.65

ALL TESTS IN ACCORDANCE WITH THE METHODS PRESCRIBED IN THE APPLICABLE ASTM SPECIFICATION. WE CERTIFY THAT THIS DATA IS A TRUE REPRESENTATION OF INFORMATION PROVIDED BY THE MATERIAL SUPPLIER AND OUR TESTING LABORATORY.
(所有检验结果均按照ASTM标准规格指定检验方式进行, 此份报告资料与原材料供应商提供数据一致, 且符合ASTM标准规格。))
MFG ISO9001 CERTIFICATE NO: B-005Q11042R03
(生产商ISO9001证书编号)

(SIGNATURE OF Q.A. LAB MGR AND MFG STAMPER)



Figure A-24. 5/8 in. Dia. Plain Round Washer, Test No. MGSS-1



Figure A-25. 7/8 in. Dia. Plain Round Washer, Test No. MGSS-1

Appendix B. Vehicle Center of Gravity Determination, Test No. MGSS-1

Test: MGSS-1

Vehicle: Ram1500

Vehicle CG Determination

VEHICLE	Equipment	Weight (lb)	Vert CG (in.)	Vert M (lb-in.)
+	Unbalasted Truck (Curb)	5024	28.2029	141691.4
+	Brake receivers/wires	6	51	306
+	Brake Frame	13	24	312
+	Brake Cylinder (Nitrogen)	22	26	572
+	Strobe/Brake Battery	6	30	180
+	Hub	27	15	405
+	CG Plate (Data Units)	8	30	240
-	Battery	-41	38	-1558
-	Oil	-9	18	-162
-	Interior	-75	25	-1875
-	Fuel	-130	17	-2210
-	Coolant	-17	33	-561
-	Washer fluid	-6	41	-246
BALLAST	Water	170	17	2890
	Misc.			0
	Misc.			0
				139984.4

Estimated Total Weight (lb)	4998
Vertical CG Location (in.)	28.00808

wheel base (in.) 140.5

MASH Targets	Targets	Test Inertial	Difference
Test Inertial Weight (lb)	5000 ± 110	4992	-8.0
Long CG (in.)	63 ± 4	64.48	1.48027
Lat CG (in.)	NA	0.094827	NA
Vert CG (in.) ≥	28	28.01	0.00808

Note: Long. CG is measured from front axle of test vehicle

Note: Lateral CG measured from centerline - positive to vehicle right (passenger) side

	Left	Right
Front	1438	1321
Rear	1102	1163
FRONT	2759 lb	
REAR	2265 lb	
TOTAL	5024 lb	

	Left	Right
Front	1379	1322
Rear	1110	1181
FRONT	2701 lb	
REAR	2291 lb	
TOTAL	4992 lb	

Figure B-1. Vehicle Mass Distribution, Test No. MGSS-1

Appendix C. Static Soil Tests, Test No. MGSS-1

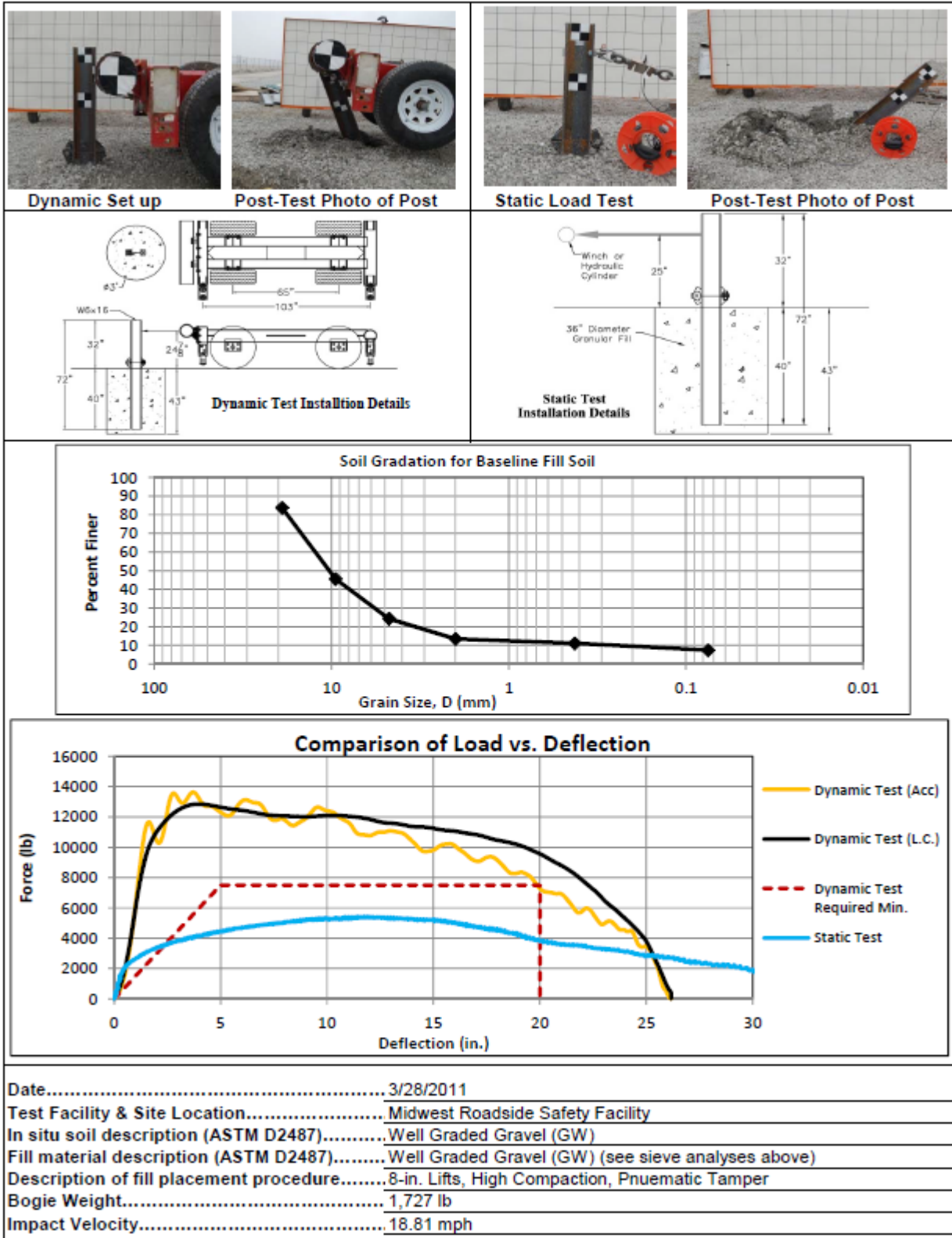

Figure C-1. Soil Strength, Initial Calibration Tests, Test No. MGSS-1

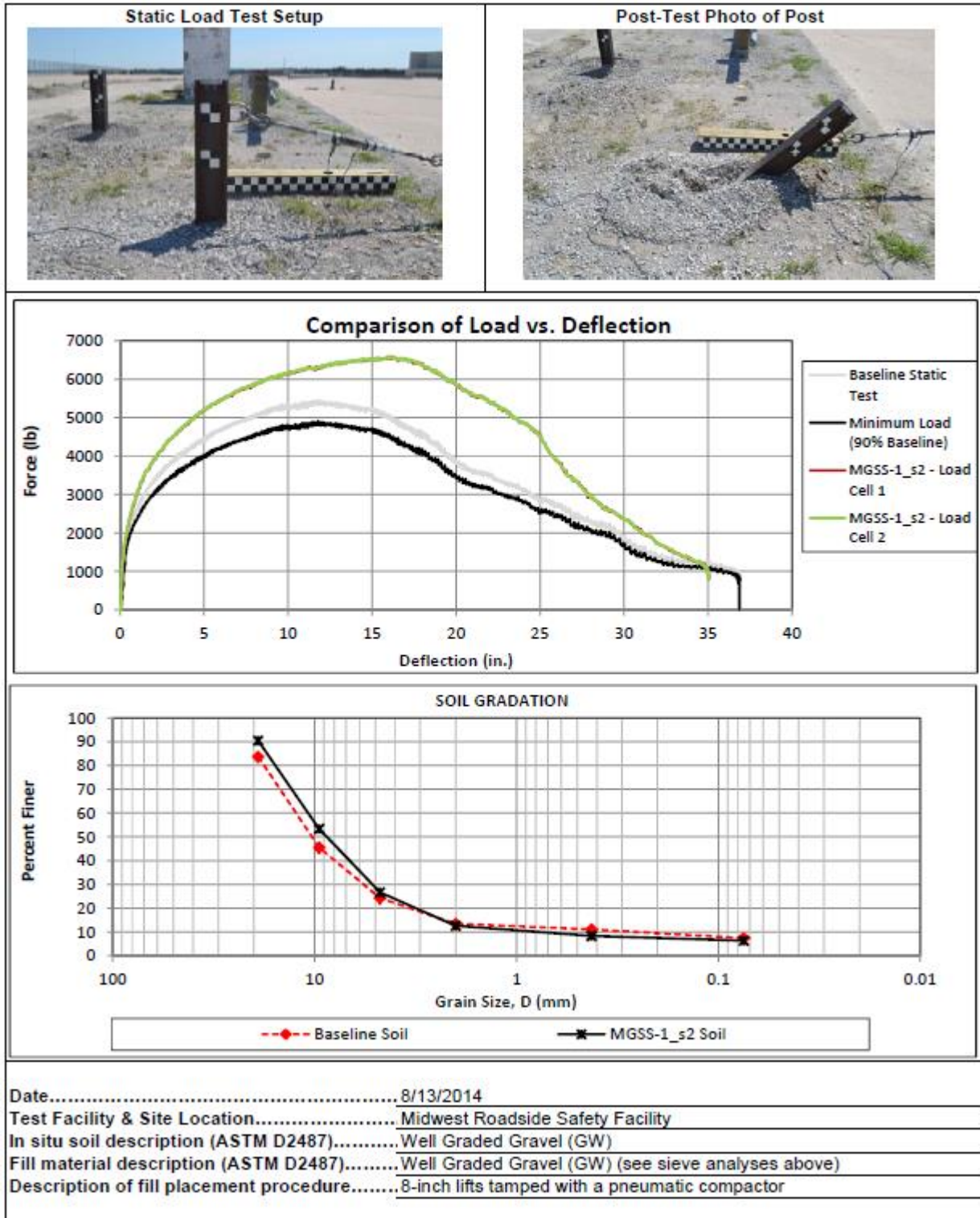

Figure C-2. Static Soil Test S2, Test No. MGSS-1

Appendix D. Vehicle Deformation Records, Test No. MGSS-1

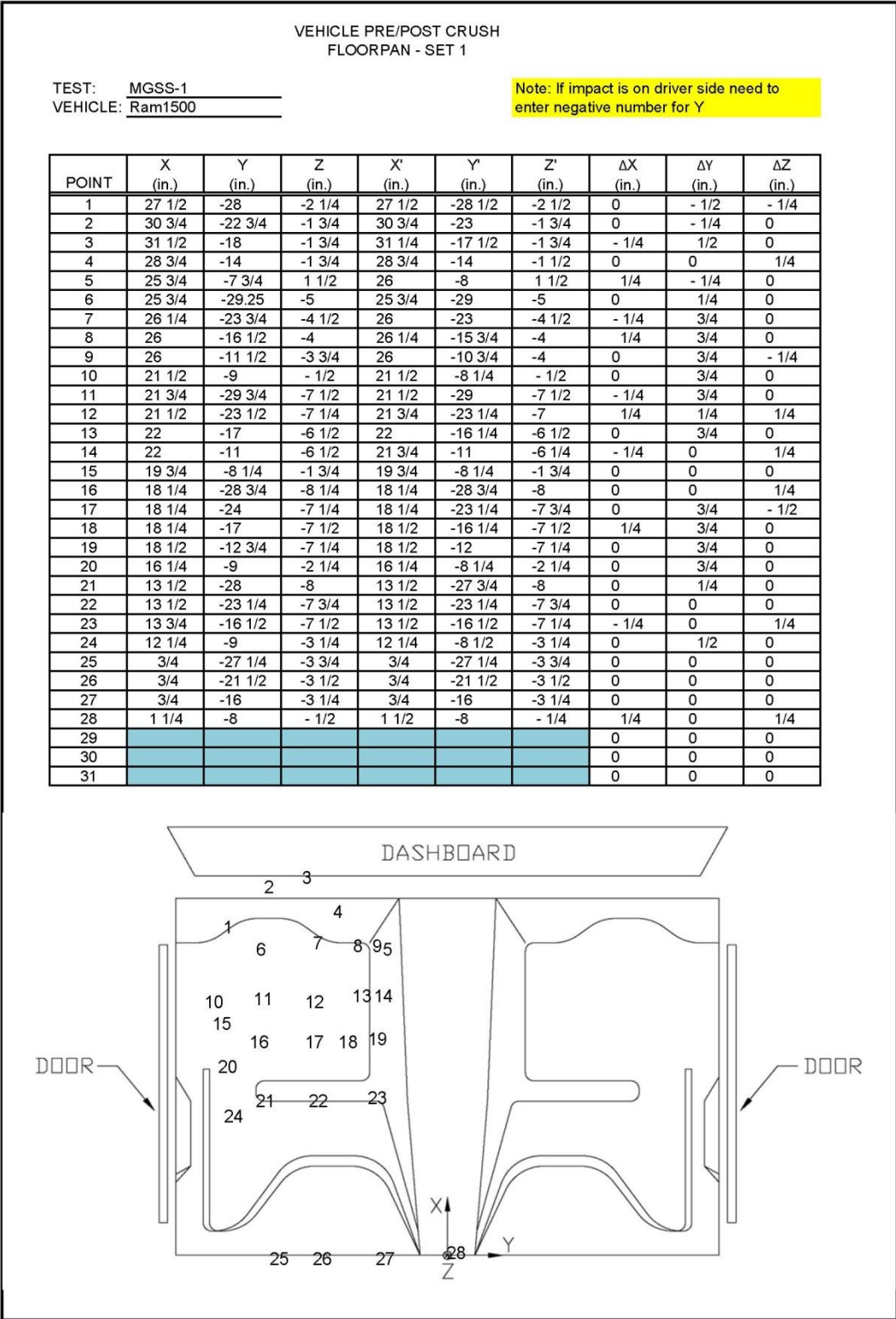

Figure D-1. Floorpan Deformation Data – Set 1, Test No. MGSS-1

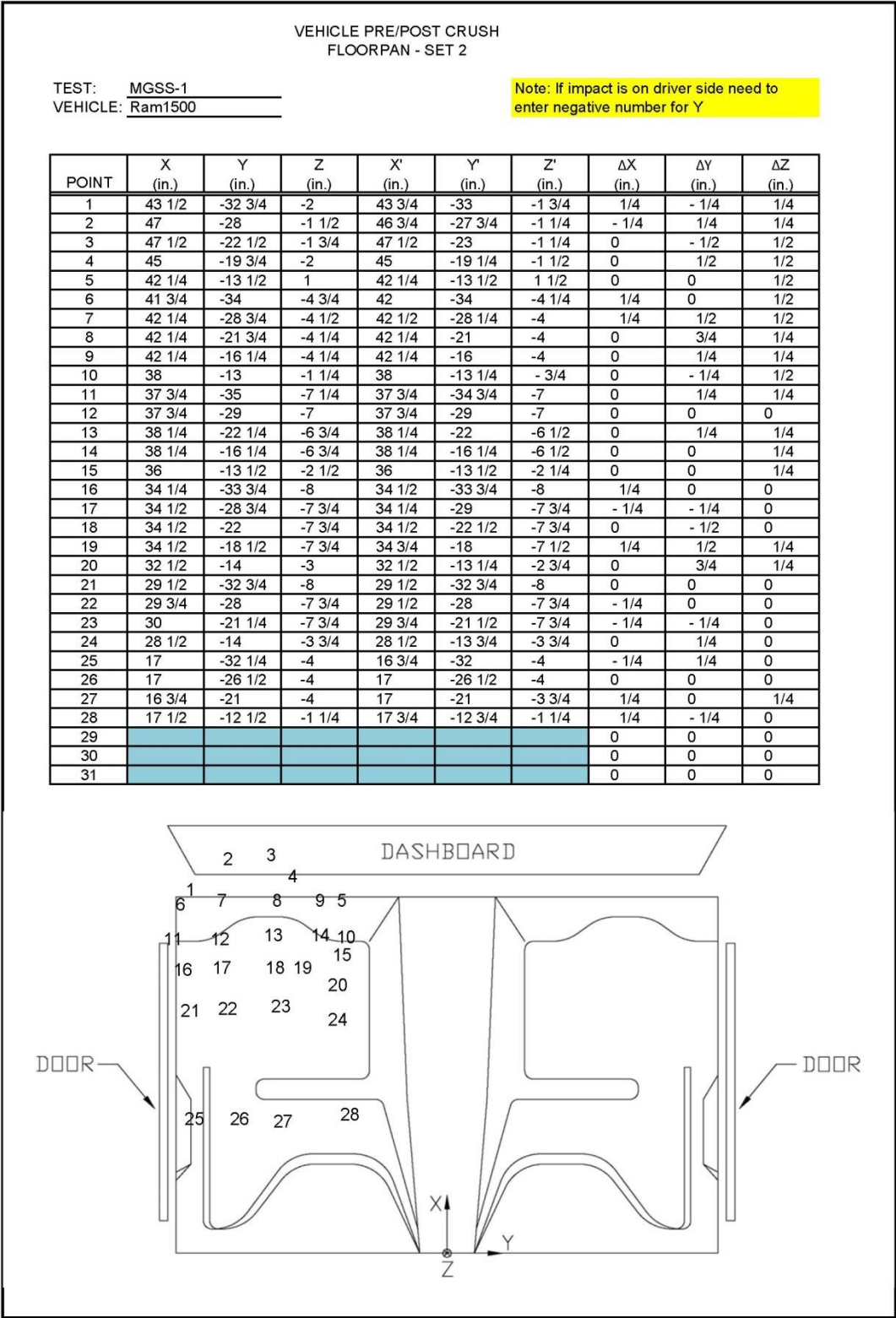

Figure D-2. Floorpan Deformation Data – Set 2, Test No. MGSS-1

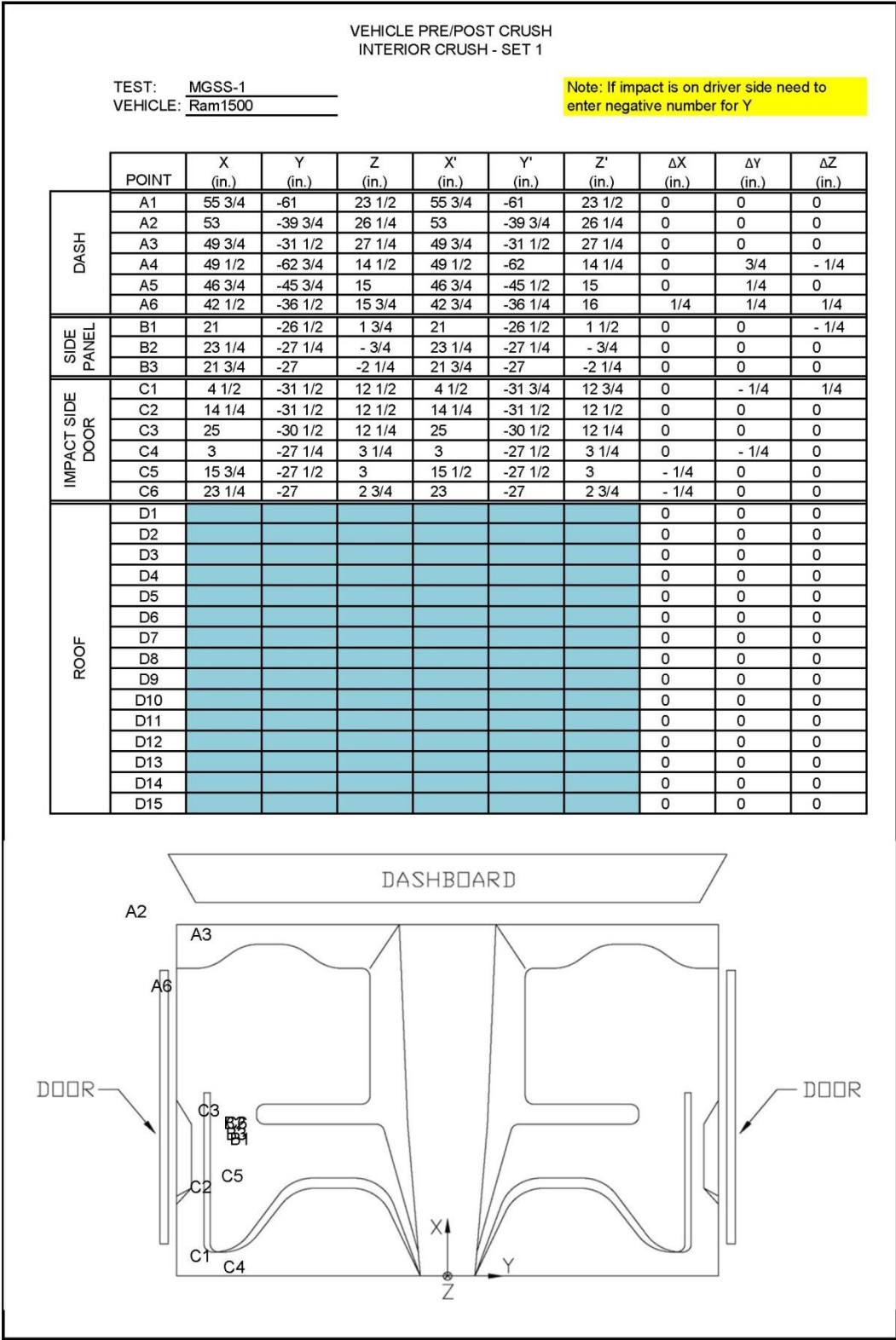

Figure D-3. Occupant Compartment Deformation Data – Set 1, Test No. MGSS-1

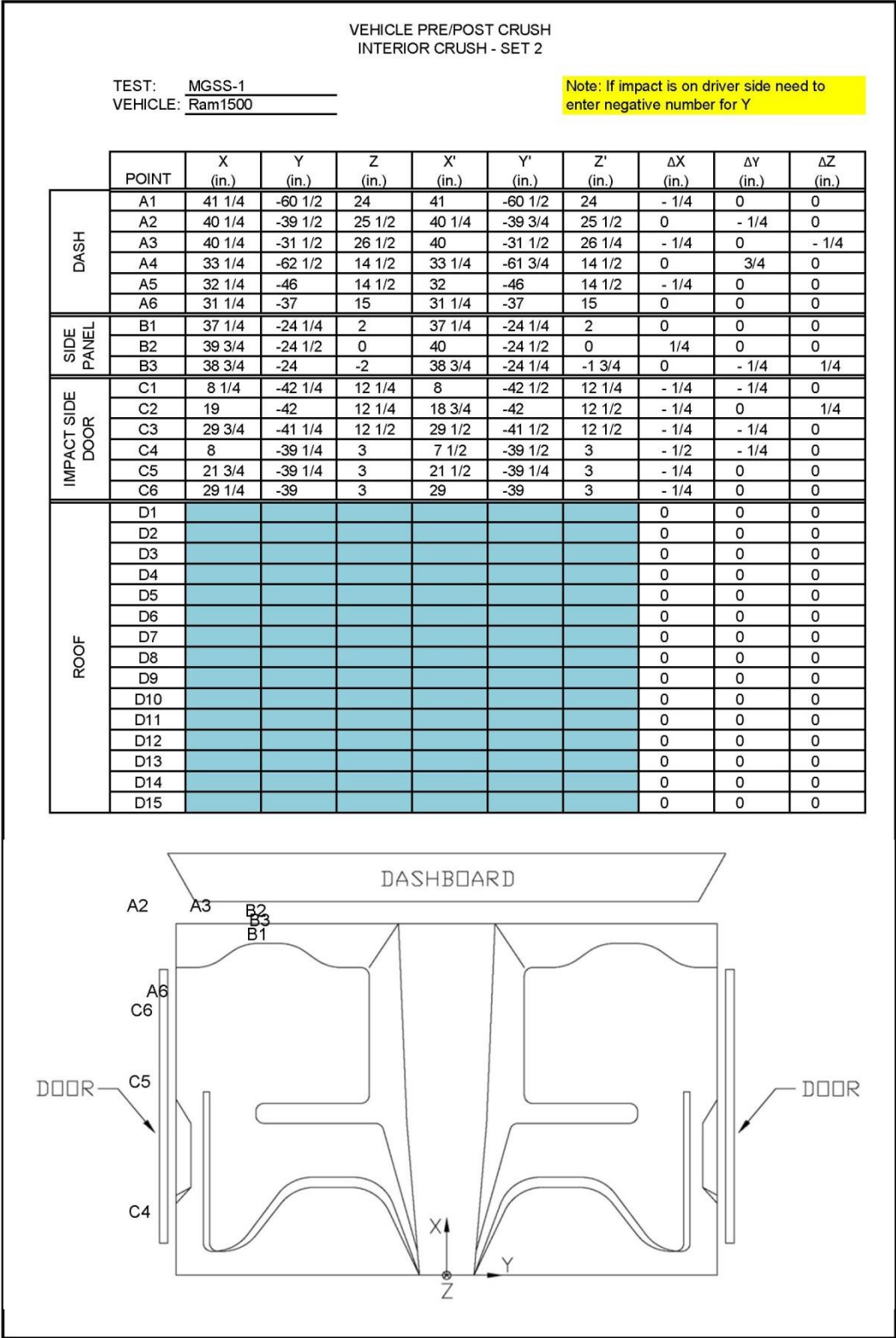

Figure D-4. Occupant Compartment Deformation Data – Set 2, Test No. MGSS-1

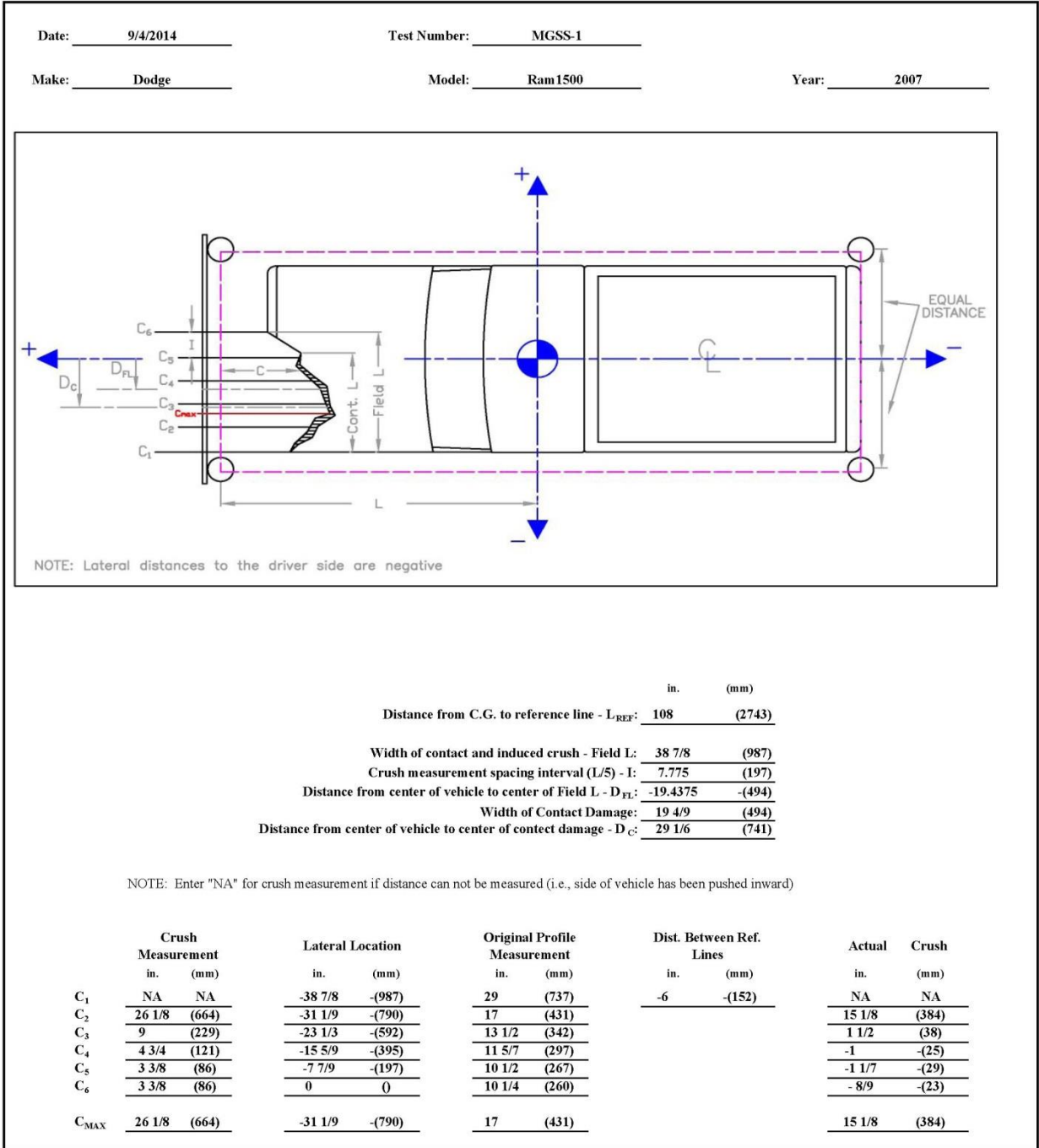

Figure D-5. Exterior Vehicle Crush (NASS) - Front, Test No. MGSS-1

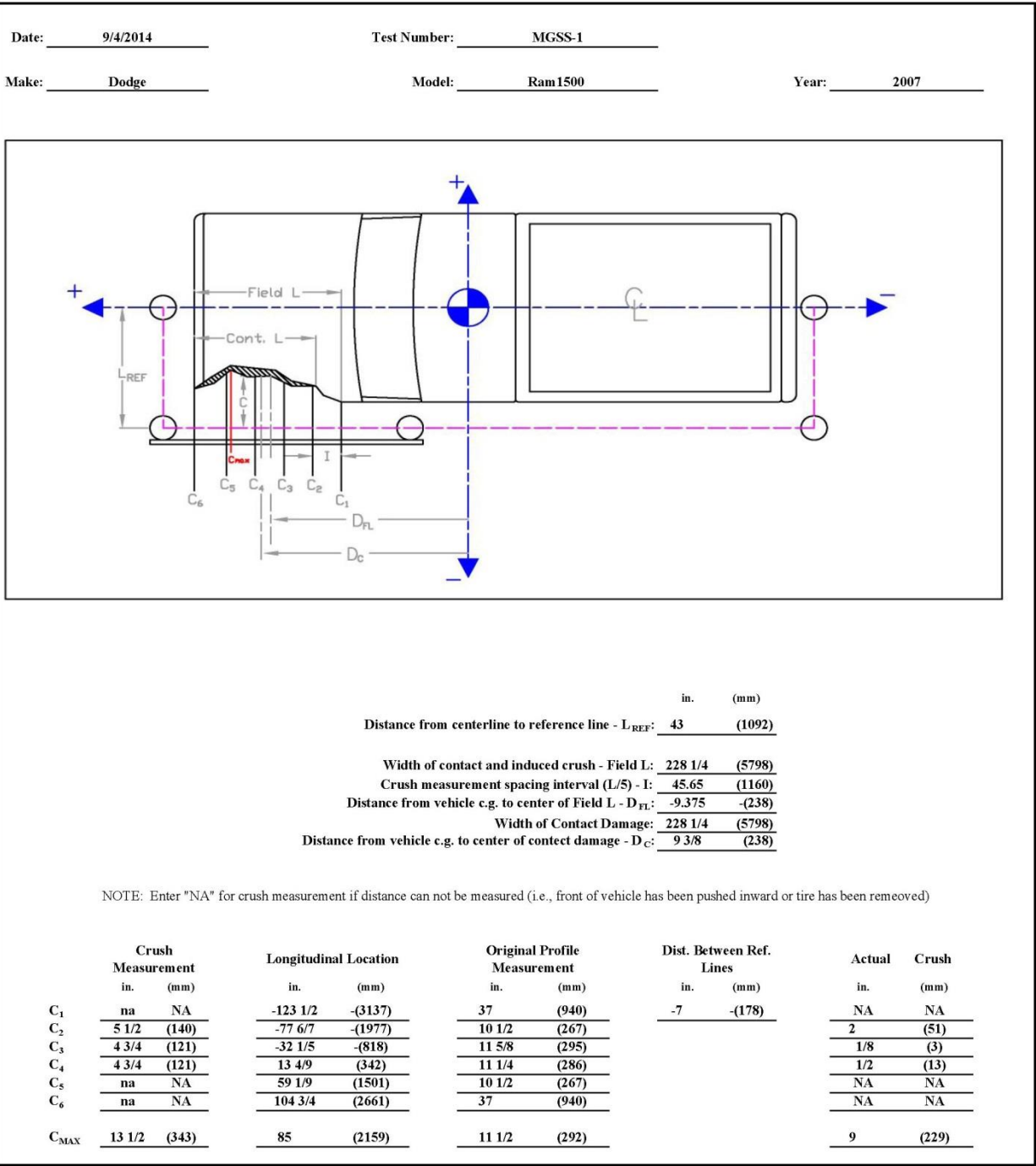

Figure D-6. Exterior Vehicle Crush (NASS) - Side, Test No. MGSS-1

Appendix E. Accelerometer and Rate Transducer Data Plots, Test No. MGSS-1

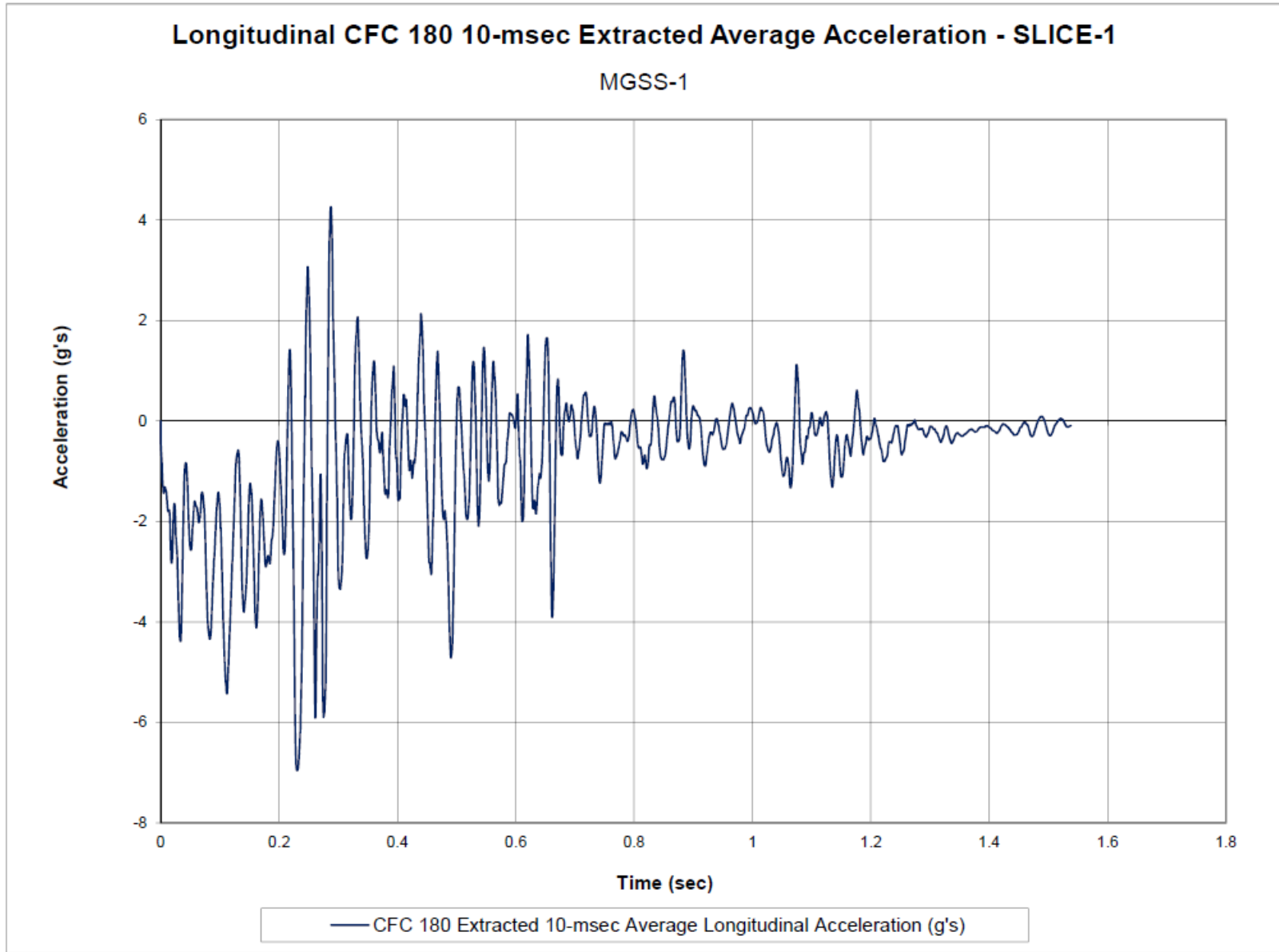

Figure E-1. 10-ms Average Longitudinal Deceleration (SLICE-1), Test No. MGSS-1

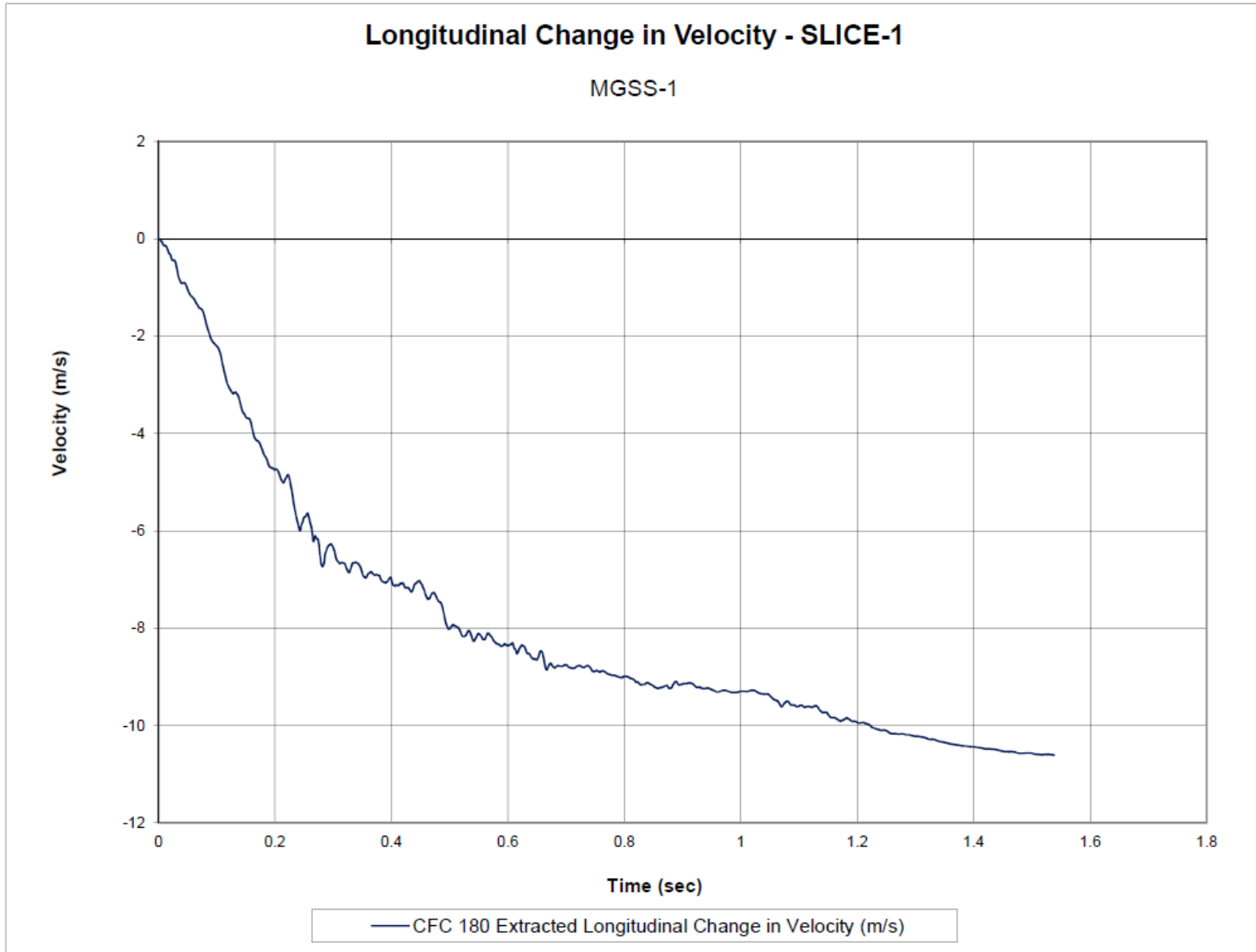

Figure E-2. Longitudinal Occupant Impact Velocity (SLICE-1), Test No. MGSS-1

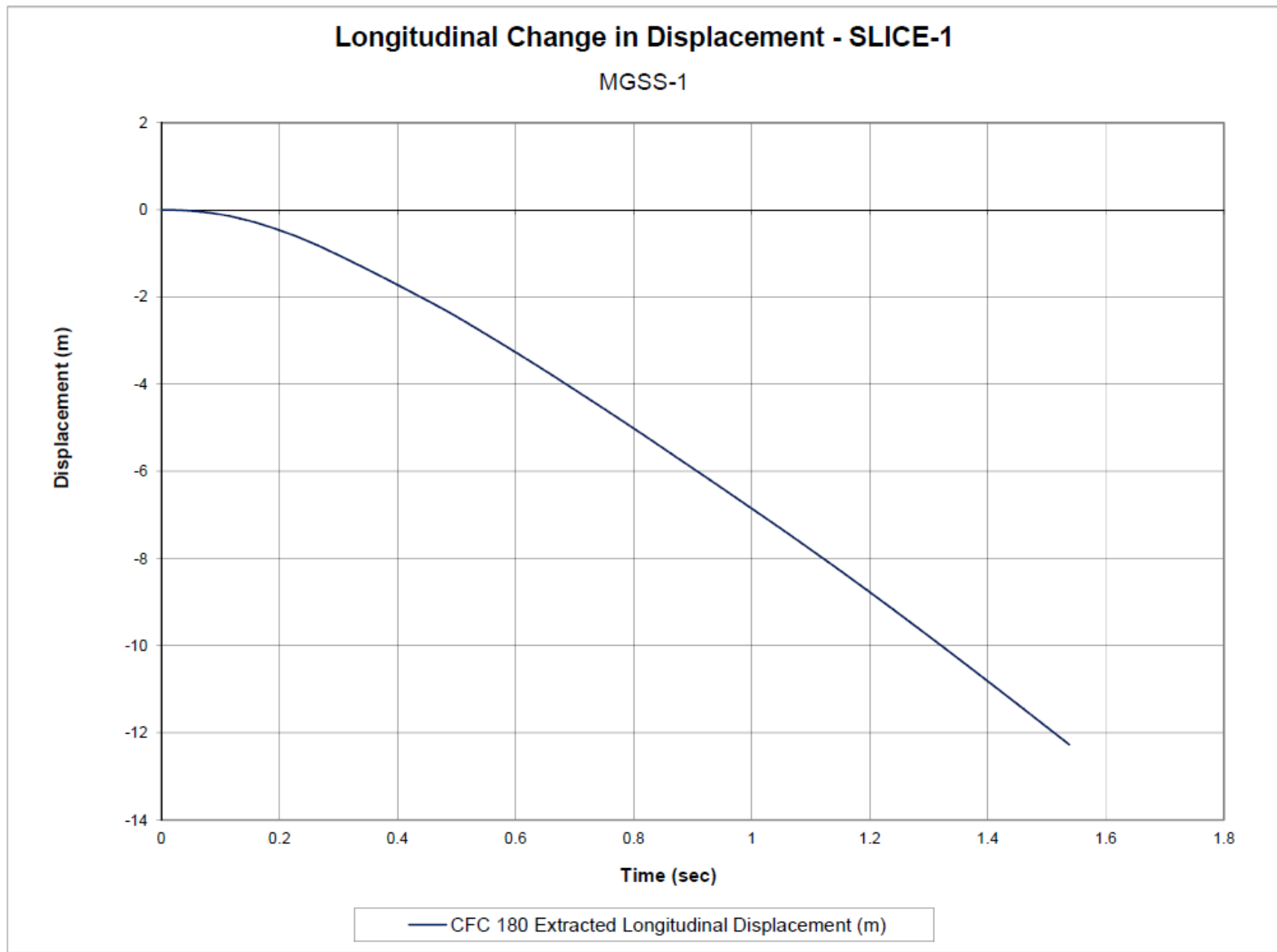

Figure E-3. Longitudinal Occupant Displacement (SLICE-1), Test No. MGSS-1

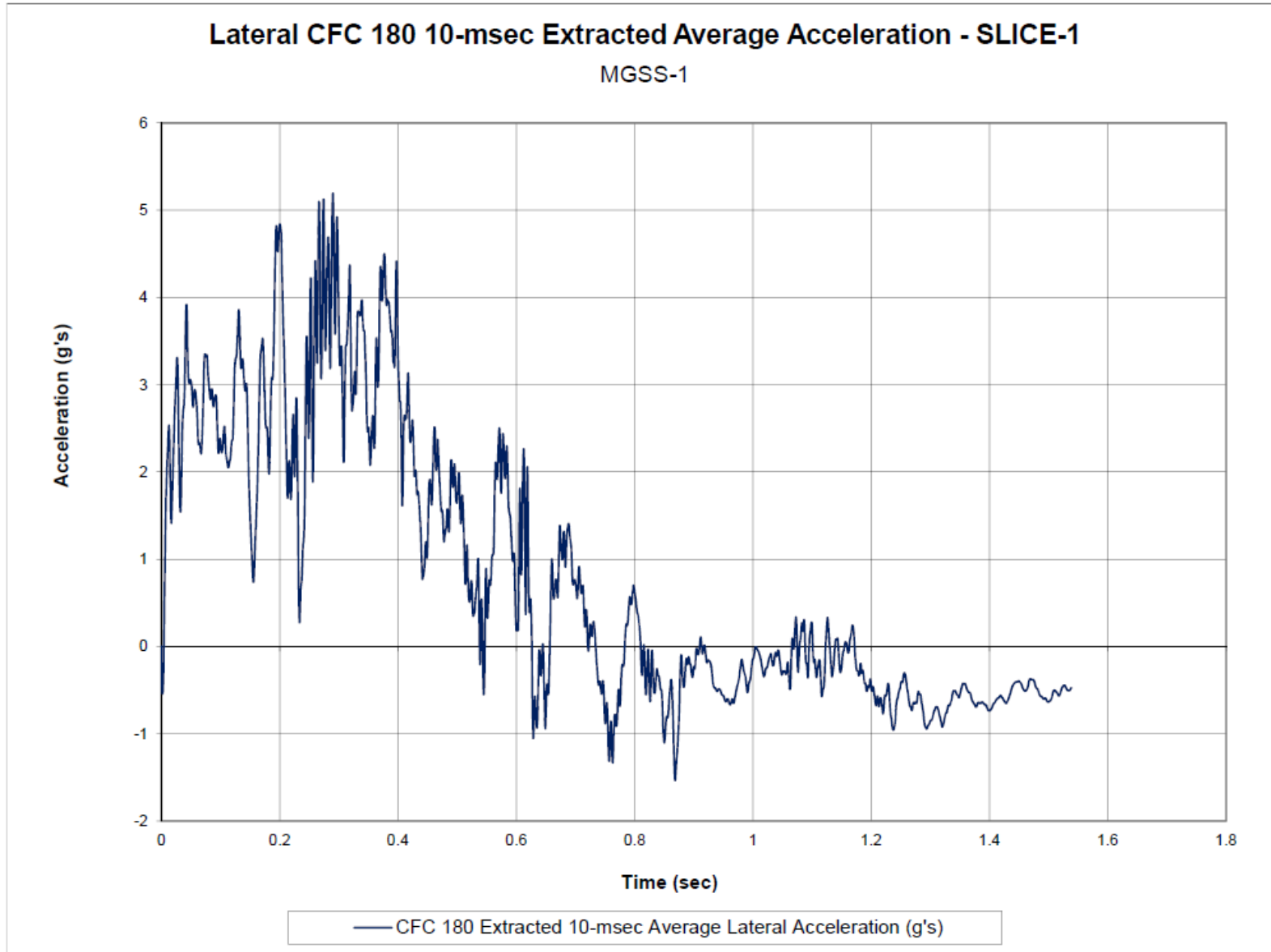

Figure E-4. 10-ms Average Lateral Deceleration (SLICE-1), Test No. MGSS-1

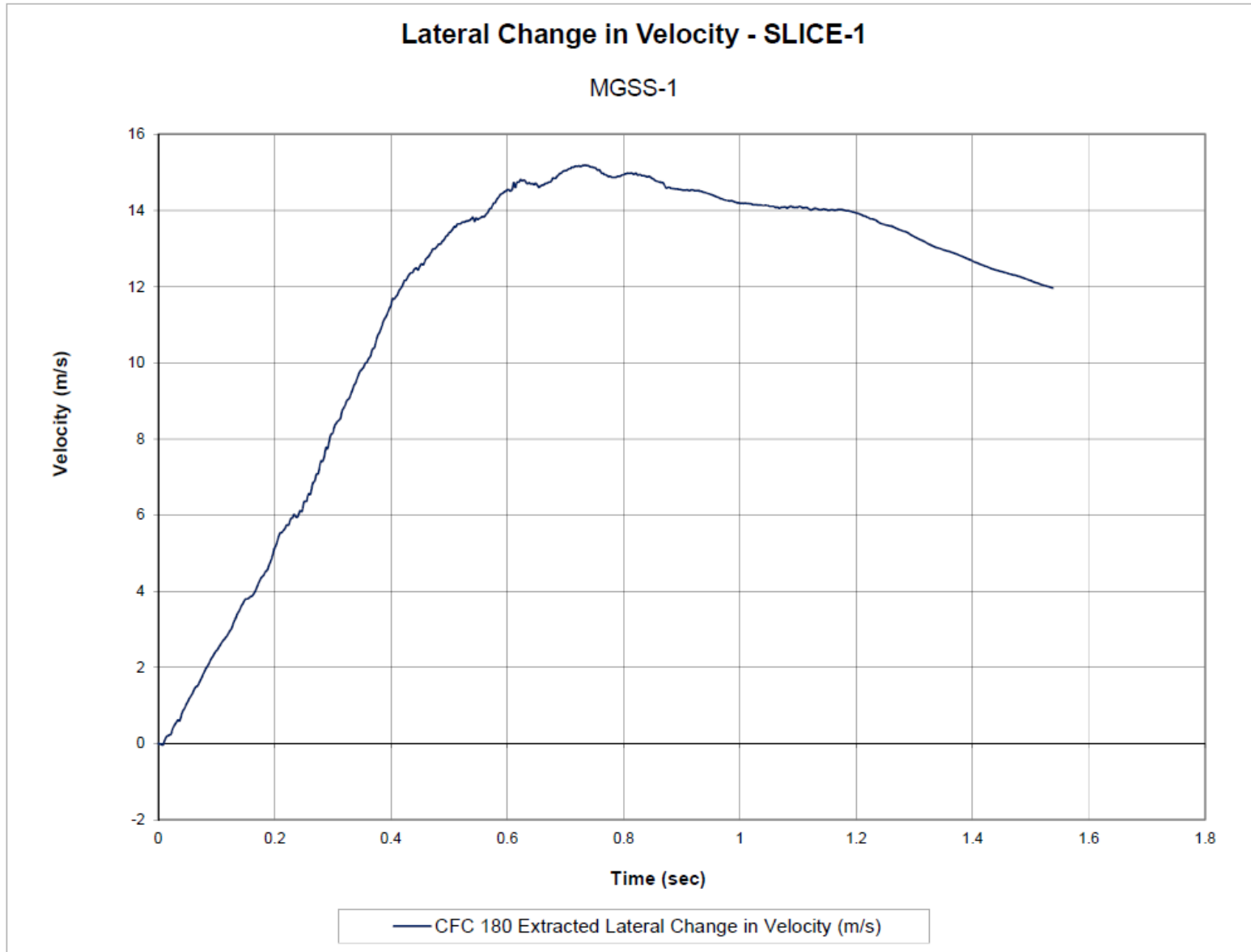

Figure E-5. Lateral Occupant Impact Velocity (SLICE-1), Test No. MGSS-1

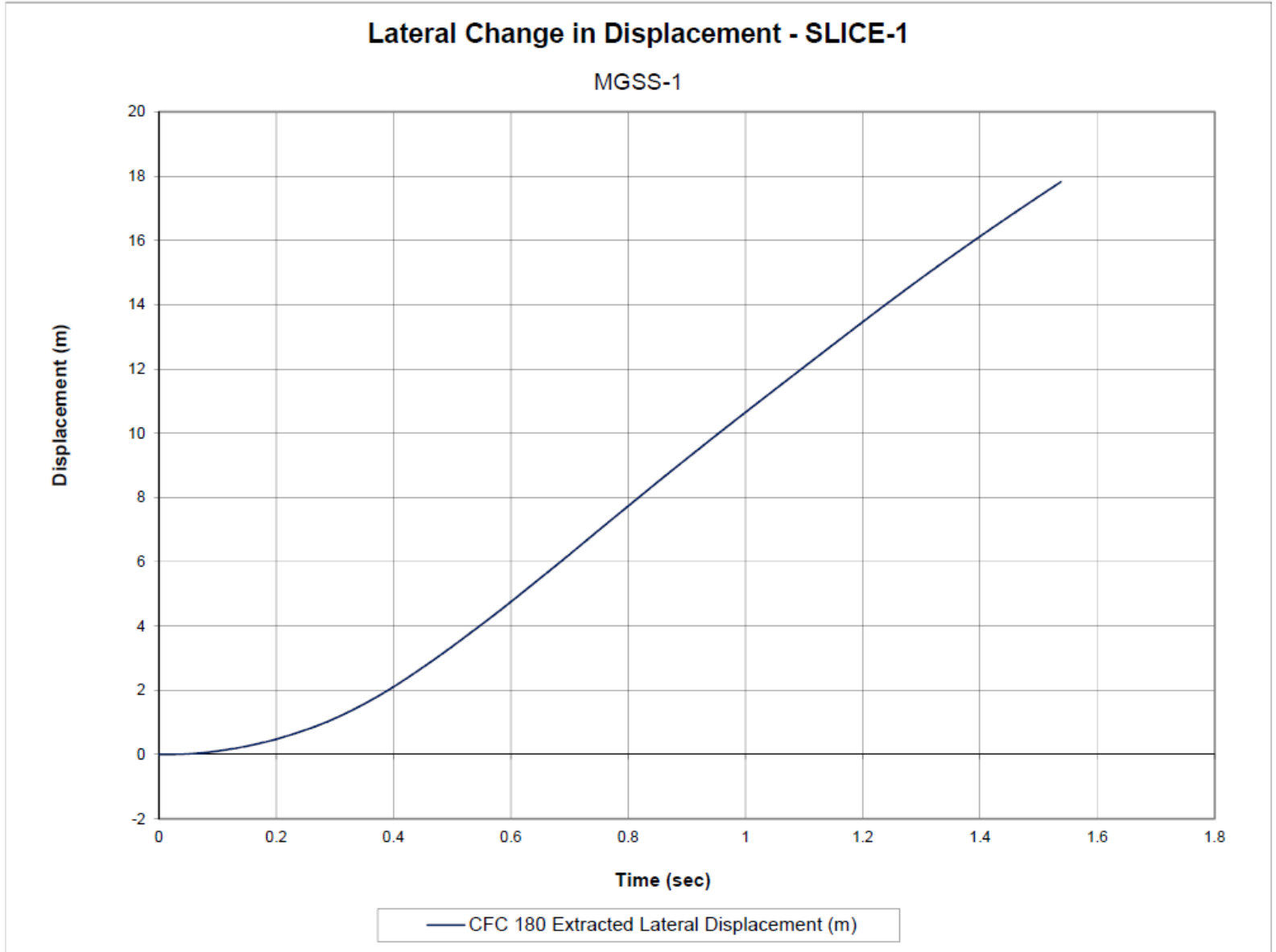

Figure E-6. Lateral Occupant Displacement (SLICE-1), Test No. MGSS-1

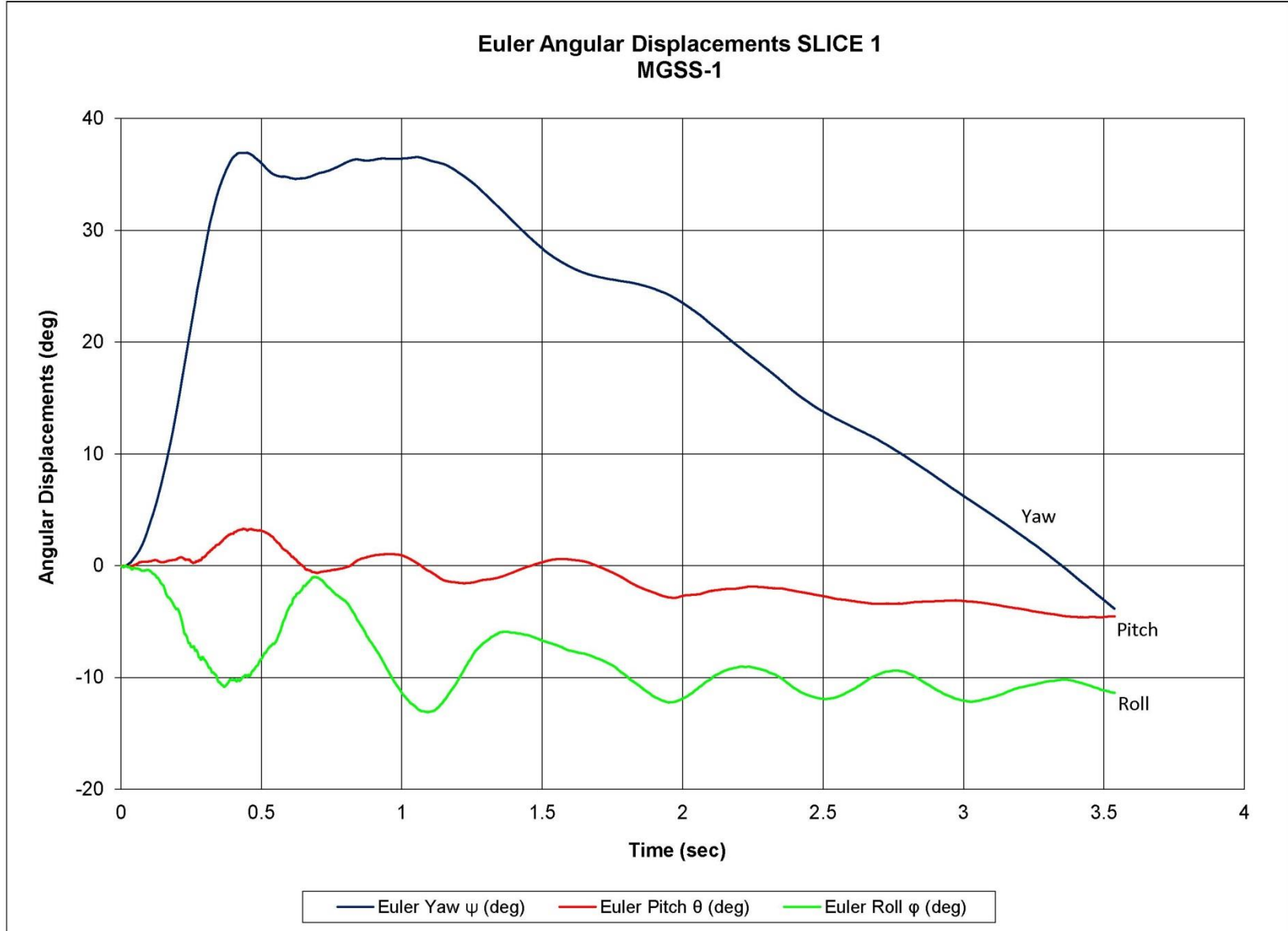

Figure E-7. Vehicle Angular Displacements (SLICE-1), Test No. MGSS-1

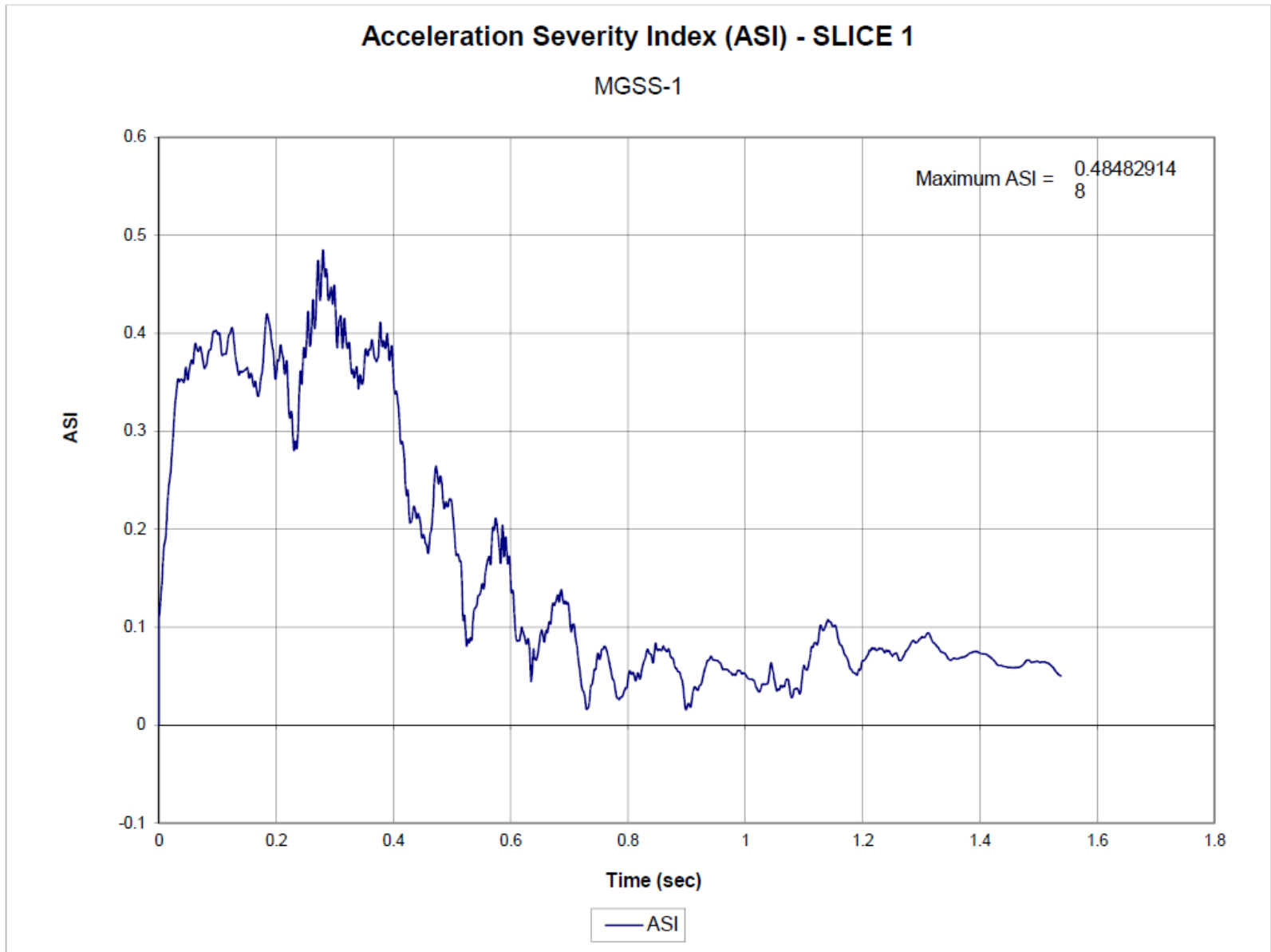

Figure E-8. Acceleration Severity Index (SLICE-1), Test No. MGSS-1

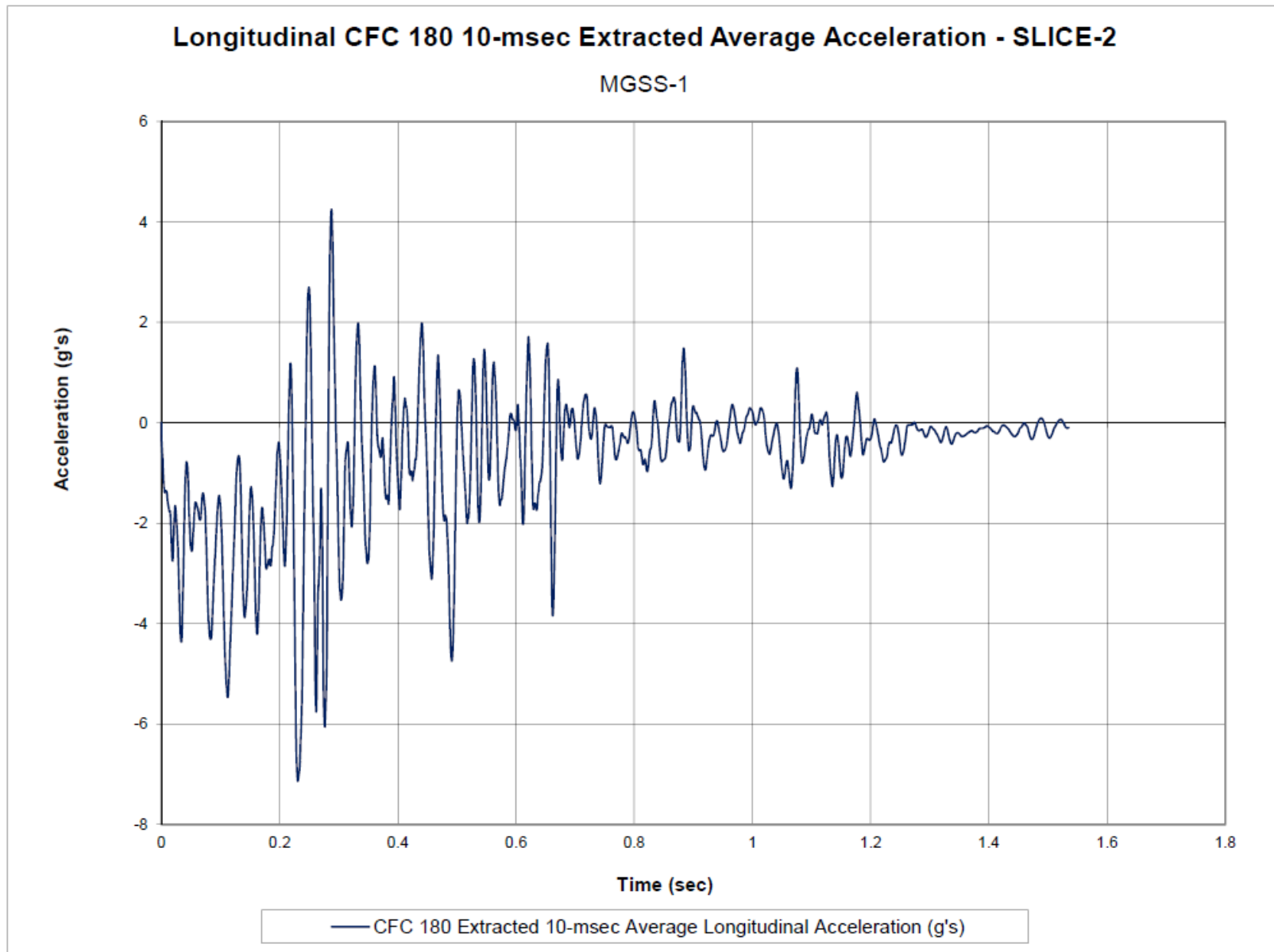

Figure E-9. 10-ms Average Longitudinal Deceleration (SLICE-2), Test No. MGSS-1

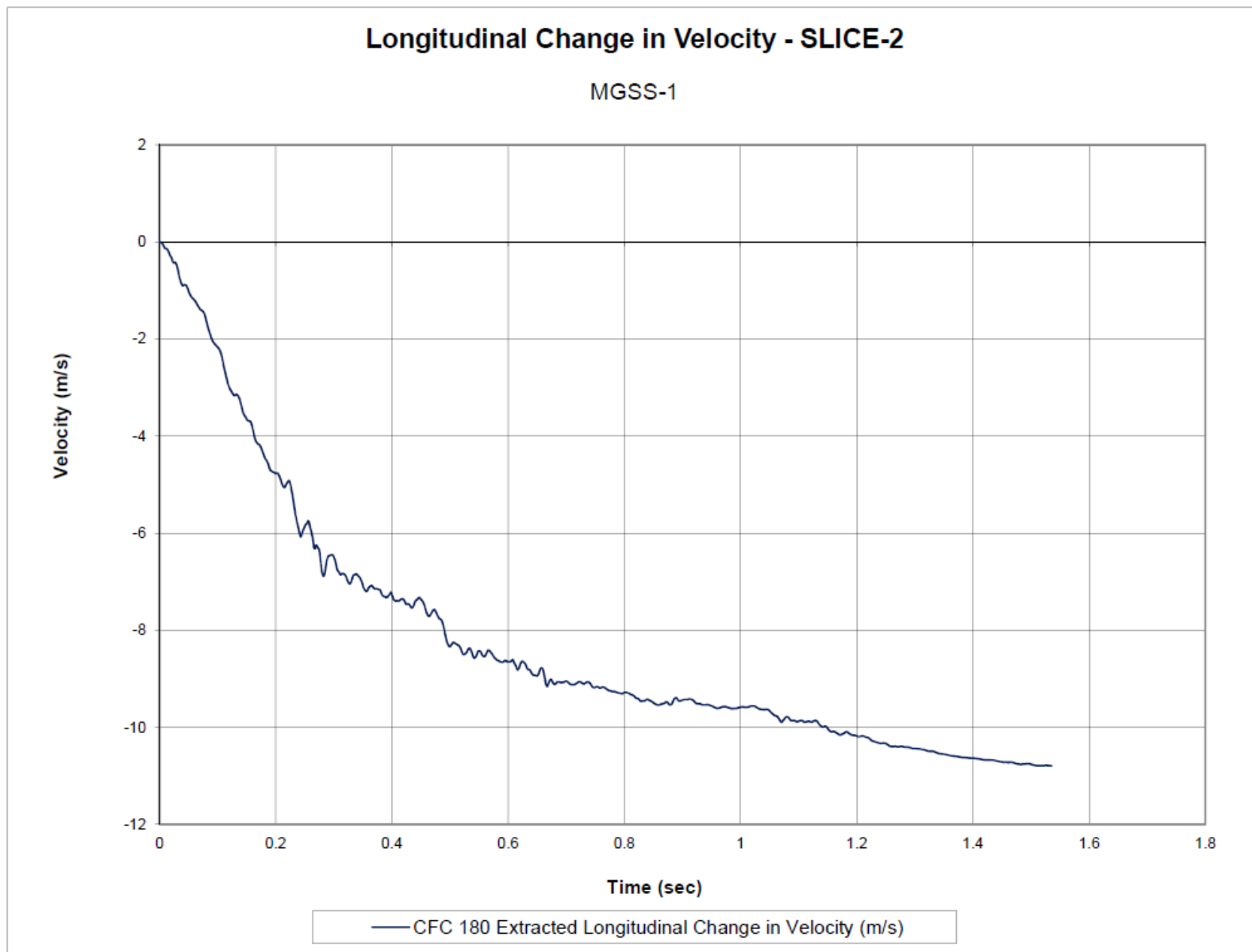

Figure E-10. Longitudinal Occupant Impact Velocity (SLICE-2), Test No. MGSS-1

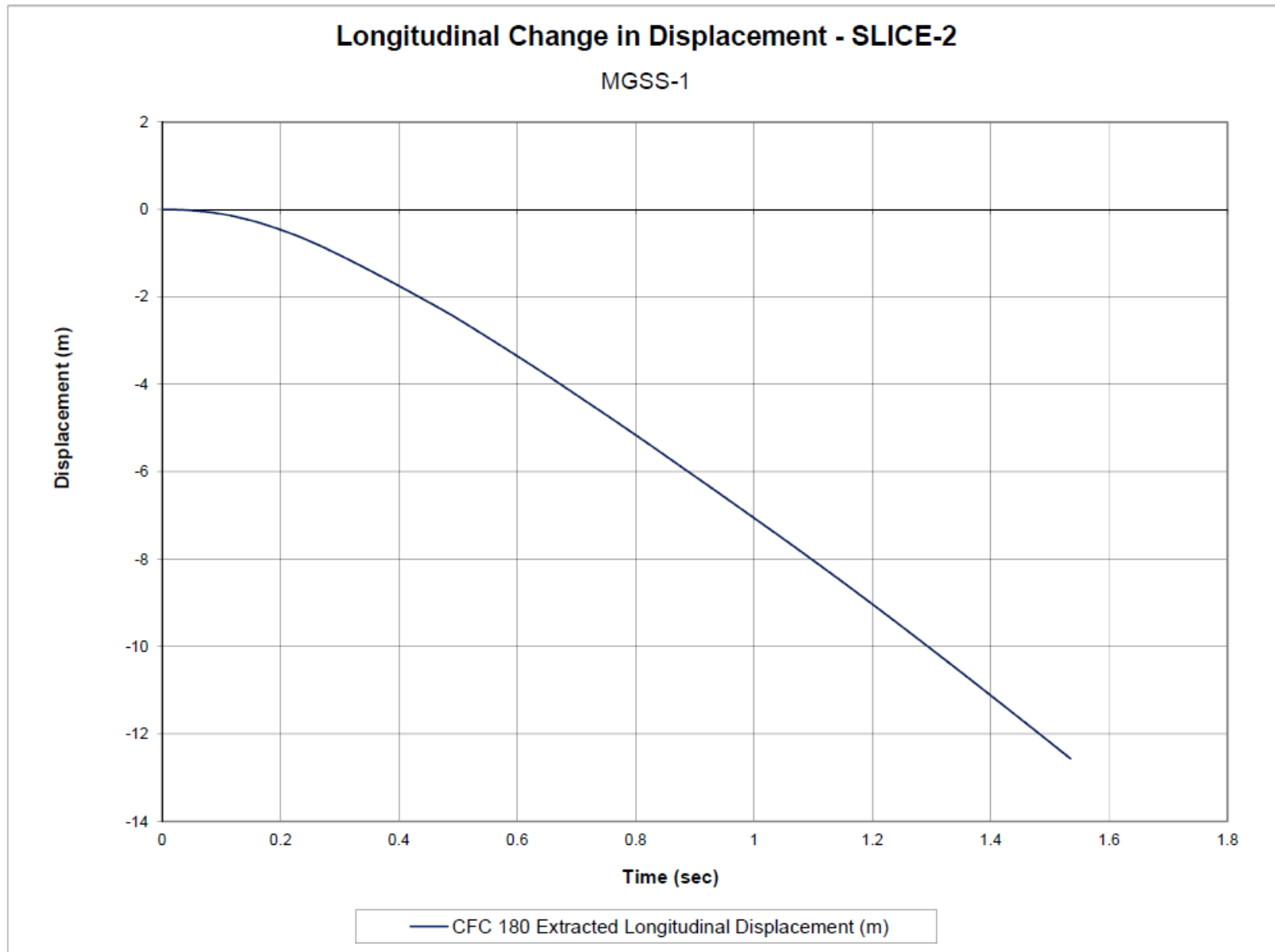

Figure E-11. Longitudinal Occupant Displacement (SLICE-2), Test No. MGSS-1

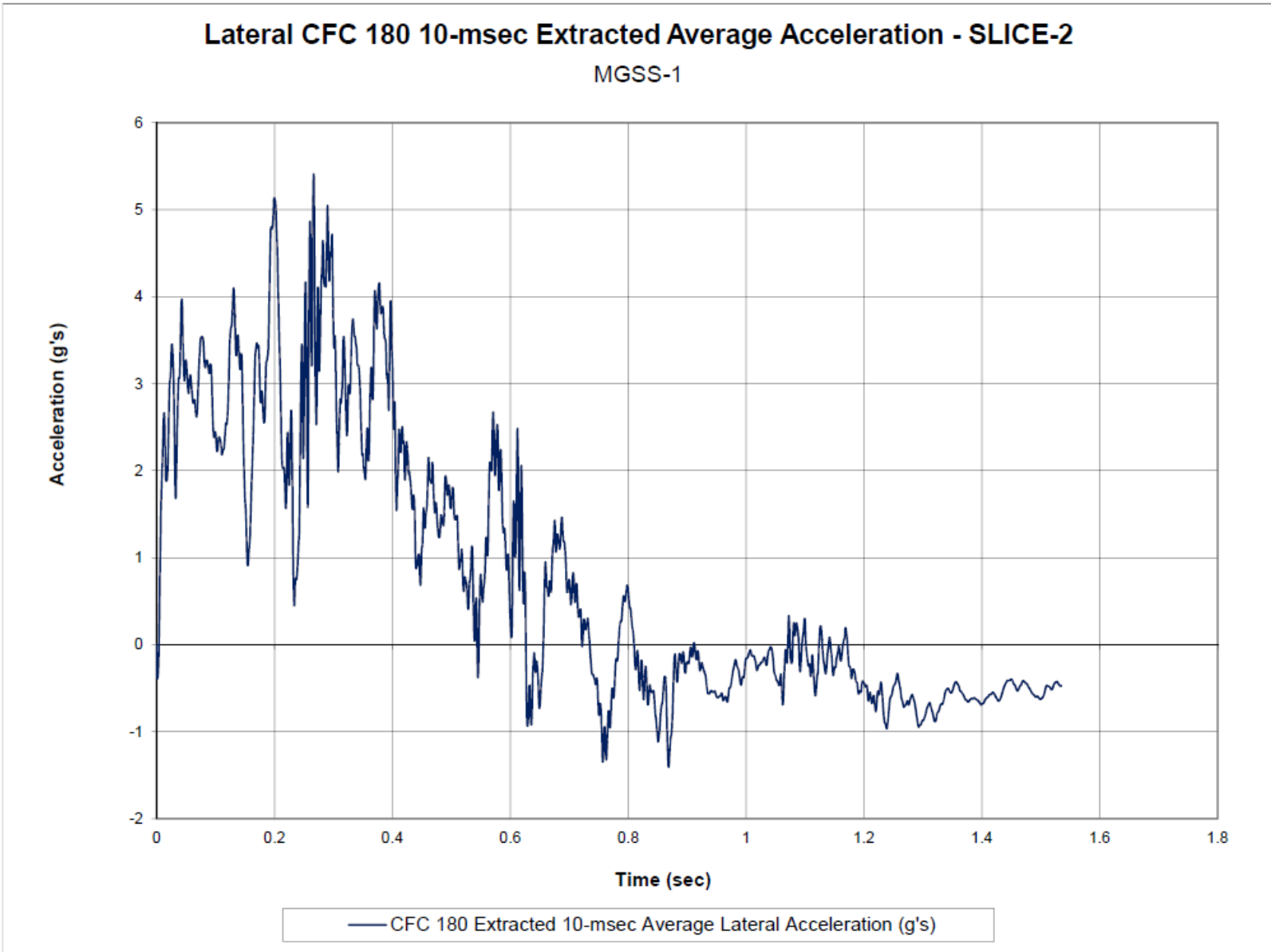

Figure E-12. 10-ms Average Lateral Deceleration (SLICE-2), Test No. MGSS-1

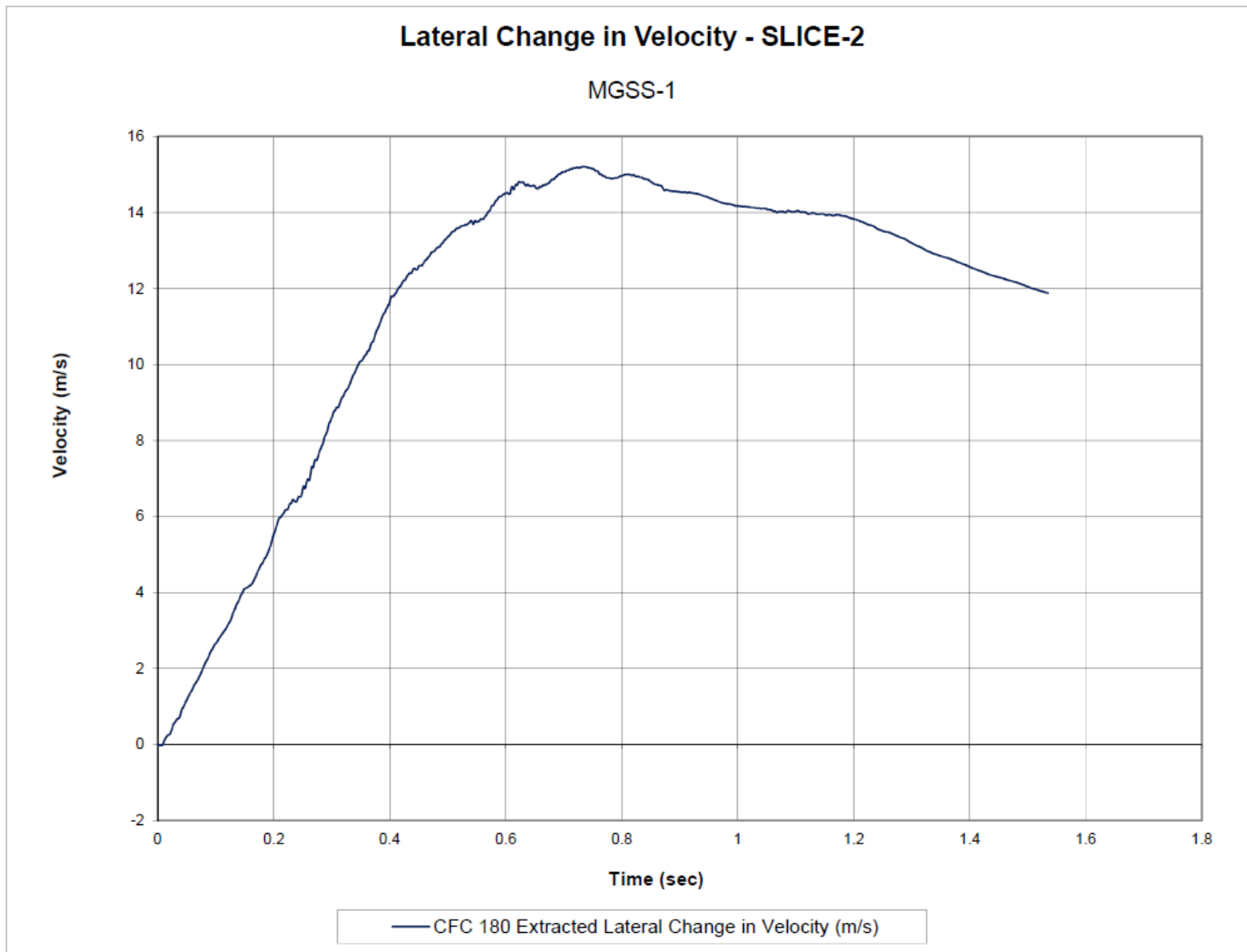

Figure E-13. Lateral Occupant Impact Velocity (SLICE-2), Test No. MGSS-1

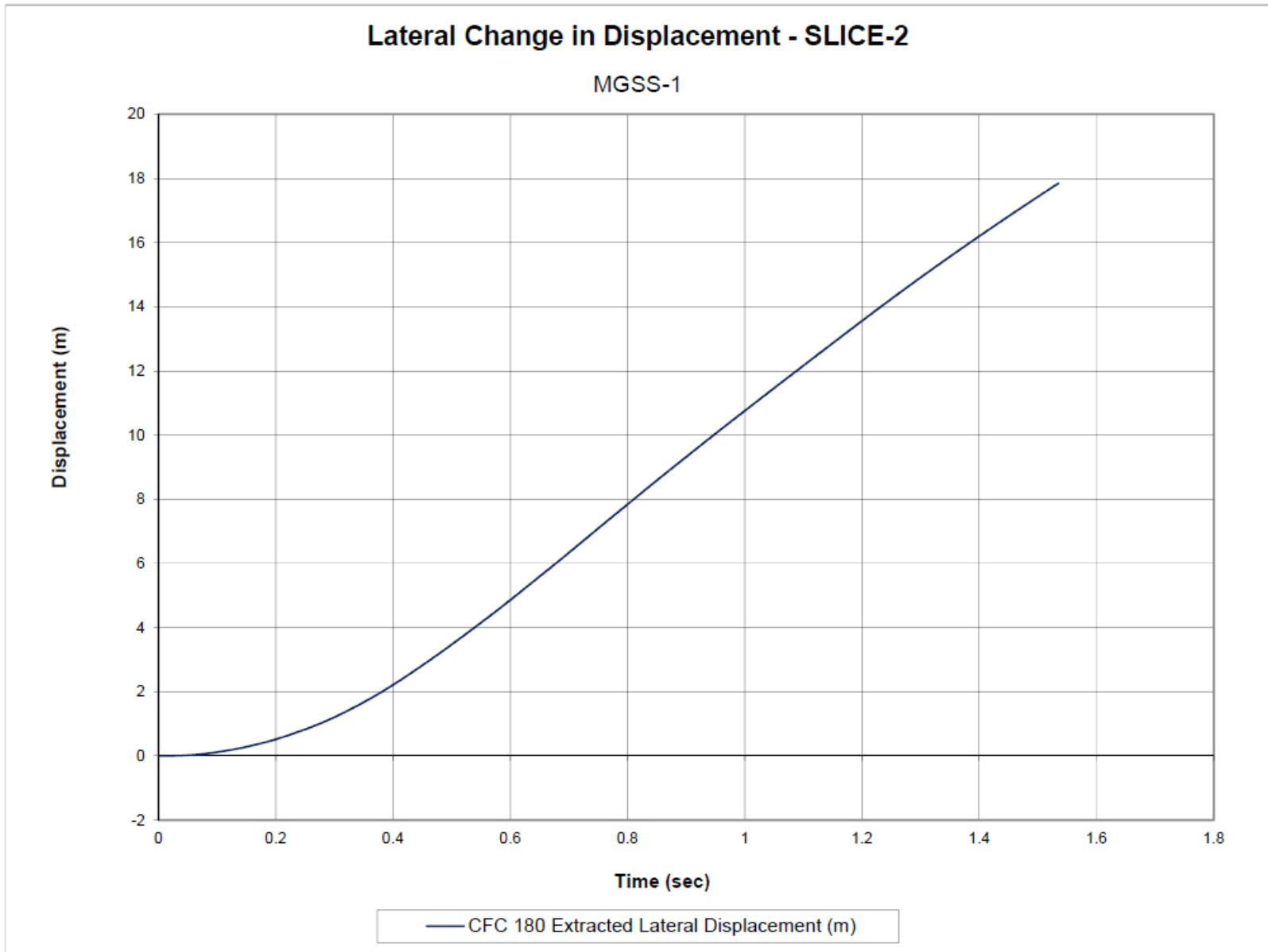

Figure E-14. Lateral Occupant Displacement (SLICE-2), Test No. MGSS-1

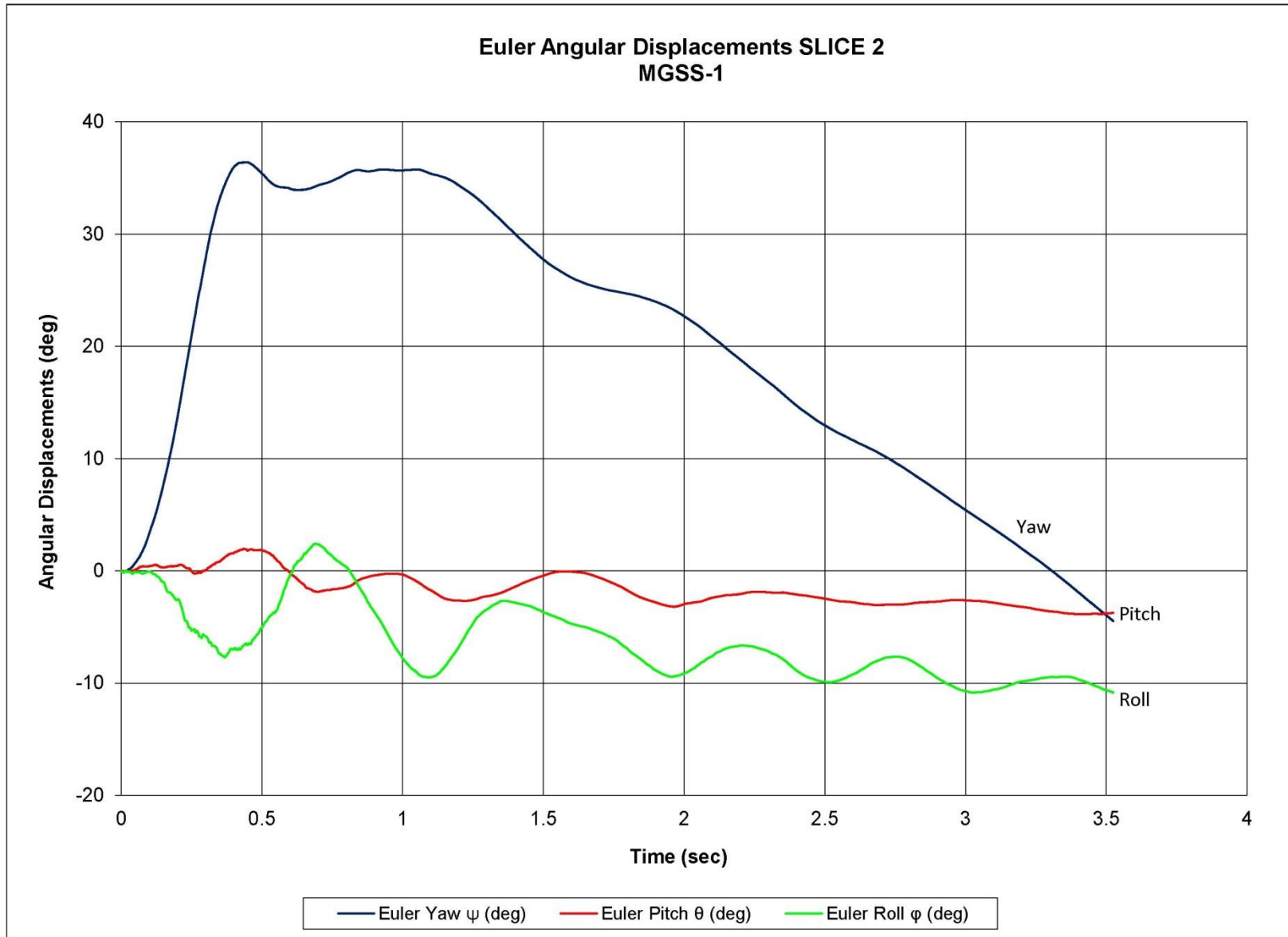

Figure E-15. Vehicle Angular Displacements (SLICE-2), Test No. MGSS-1

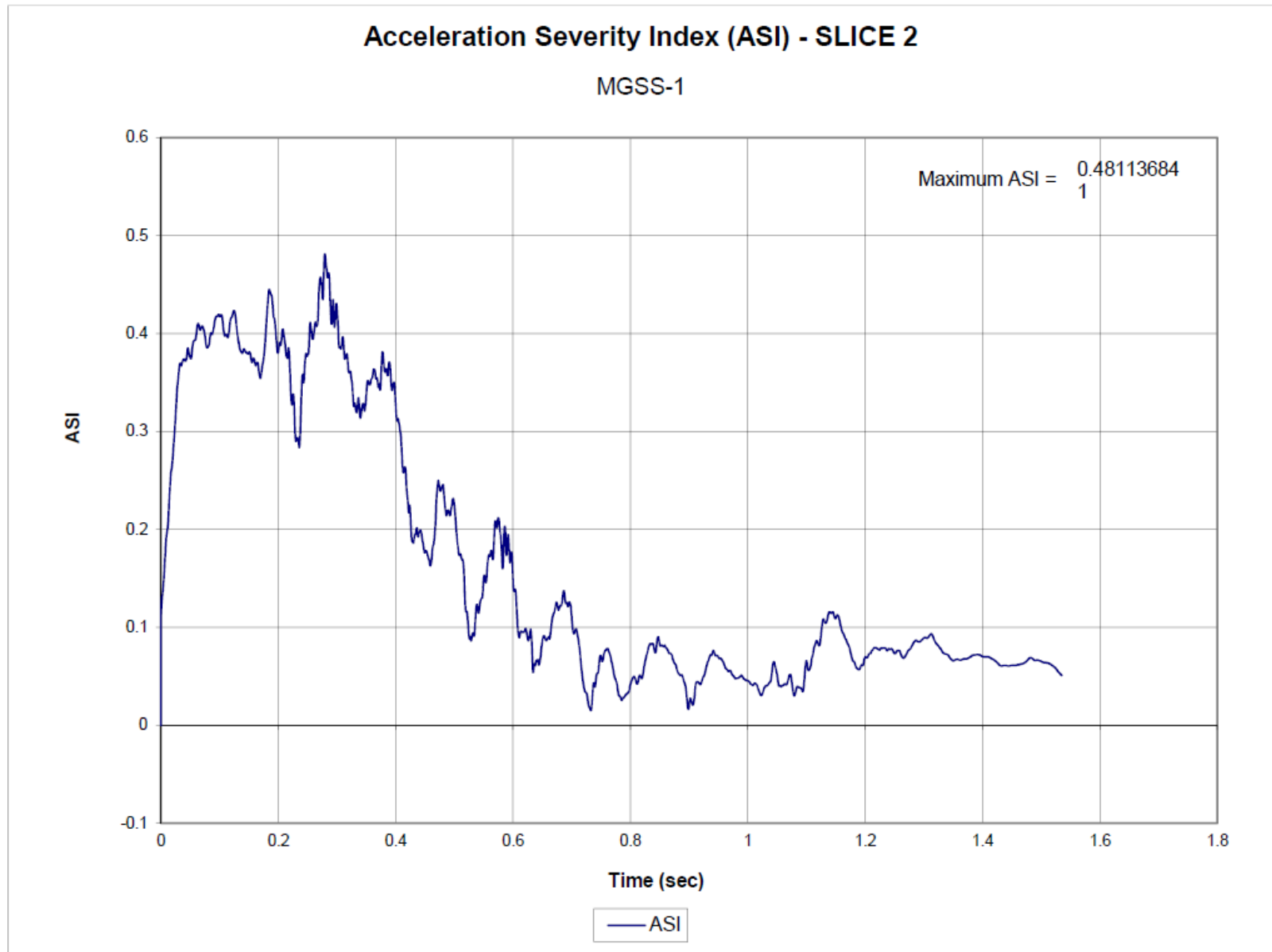

Figure E-16. Acceleration Severity Index (SLICE-2), Test No. MGSS-1

Appendix F. Load Cell Data, Test No. MGSS-1

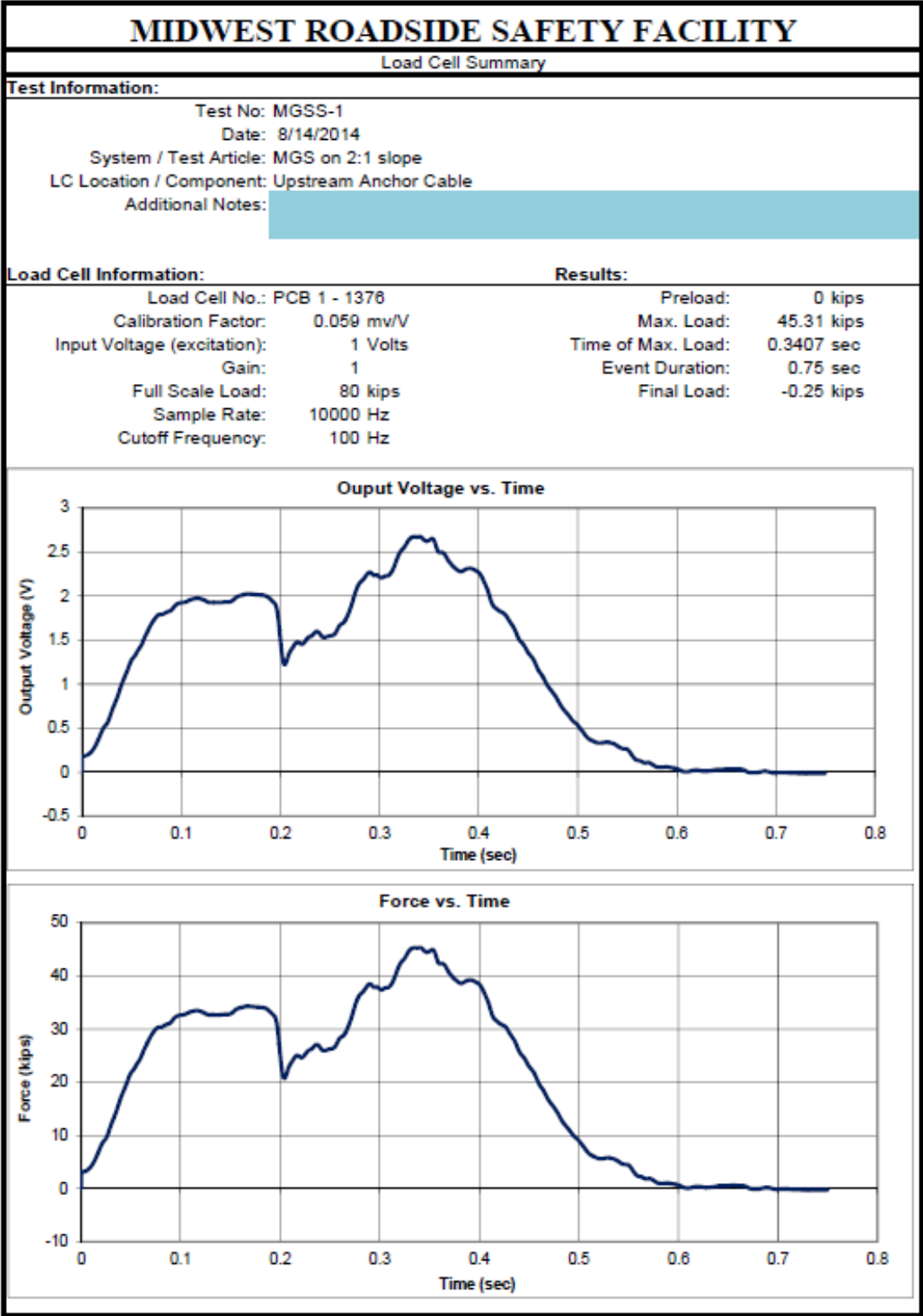

Figure F-1. Upstream Load Cell Data, Test No. MGSS-1

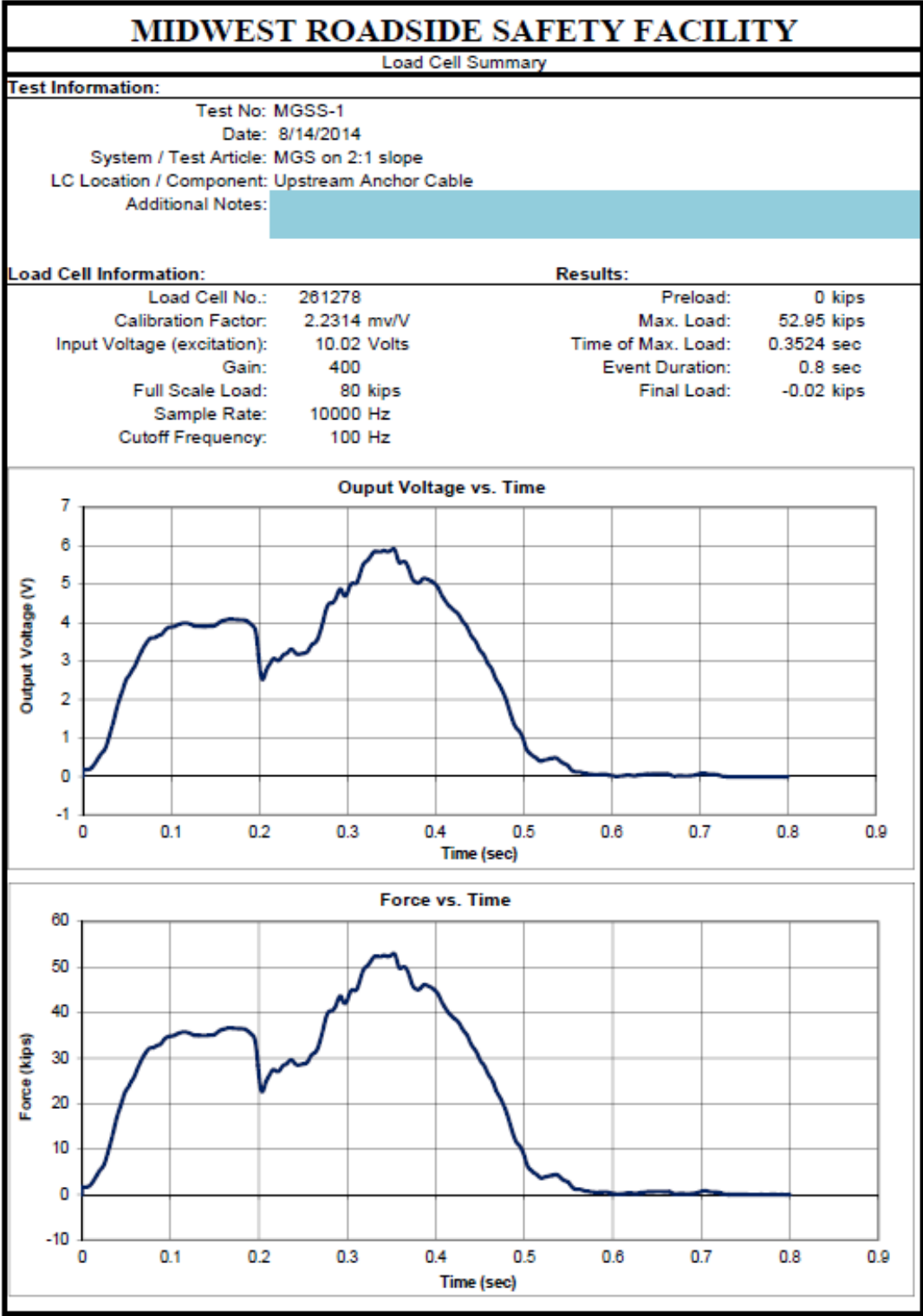

Figure F-2. Upstream Inline Load Cell Data, Test No. MGSS-1

END OF DOCUMENT