

10-1992

# SAFETY PERFORMANCE EVALUATION ON THE NEBRASKA TURNED-DOWN APPROACH TERMINAL SECTION

Ronald K. Faller

*University of Nebraska - Lincoln*, [rfaller1@unl.edu](mailto:rfaller1@unl.edu)

James C. Holloway

*University of Nebraska - Lincoln*, [jholloway1@unl.edu](mailto:jholloway1@unl.edu)

Barry Thomas Rosson

Brian G. Pfeifer

*University of Nebraska - Lincoln*

Follow this and additional works at: <http://digitalcommons.unl.edu/civilengfacpub>

---

Faller, Ronald K.; Holloway, James C.; Rosson, Barry Thomas; and Pfeifer, Brian G., "SAFETY PERFORMANCE EVALUATION ON THE NEBRASKA TURNED-DOWN APPROACH TERMINAL SECTION" (1992). *Civil Engineering Faculty Publications*. 101.  
<http://digitalcommons.unl.edu/civilengfacpub/101>

This Article is brought to you for free and open access by the Civil Engineering at DigitalCommons@University of Nebraska - Lincoln. It has been accepted for inclusion in Civil Engineering Faculty Publications by an authorized administrator of DigitalCommons@University of Nebraska - Lincoln.

SAFETY PERFORMANCE EVALUATION ON THE NEBRASKA  
TURNED-DOWN APPROACH TERMINAL SECTION



by

Ronald K. Faller  
Research Associate Engineer

James C. Holloway  
Research Associate Engineer

Barry T. Rosson, Ph.D.  
Assistant Professor

Brian G. Pfeifer  
Research Associate Engineer

James K. Luedke  
Graduate Research Assistant

submitted to

Dalyce Ronnau  
Materials and Test Division  
Midwest States Regional Pooled Fund Chairman  
Nebraska Department of Roads  
1500 Nebraska Highway 2  
Lincoln, NE 68502

Project RES 1 (0099) P464  
TRANSPORTATION RESEARCH REPORT TRP-03-32-92

conducted at

Midwest Roadside Safety Facility  
Civil Engineering Department  
University of Nebraska-Lincoln  
1901 "Y" St.  
P.O. Box 880601  
Lincoln, NE 68588-0601

October 1992

## **DISCLAIMER STATEMENT**

The contents of this report reflect the views of the authors who are responsible for the facts and the accuracy of the data presented herein. The contents do not necessarily reflect the official views or policies of the Nebraska Department of Roads nor the Federal Highway Administration. This report does not constitute a standard, specification, or regulation.

## ACKNOWLEDGEMENTS

The authors wish to express their appreciation and thanks to the members of the Midwest States Regional Pooled Fund Program and the Center for Infrastructure Research for funding the research described herein as well as the Midwest Transportation Center in Aims, Iowa for providing graduate student support. A special thanks is also given to the following individuals who made a contribution to the completion of this research project.

### Nebraska Department of Roads

Ted Watson, Project Contact  
Dalyce Ronnau, Materials and Test Division  
Leona Kolbet, Research Coordinator  
Ann White, Technical Research Library

### Missouri Department of Transportation

Dan Davidson, Design Division

### Kansas Department of Transportation

Ron Seitz, Road Design Squad Leader

### Center for Infrastructure Research

Maher Tadros, Ph.D., Director  
Sammy Elias, Ph.D., Associate Dean for Engineering Research Center

### Midwest Transportation Center

Tom Maze, Ph.D., Director

### Federal Highway Administration

Bill Wendling, Safety Program Engineer, Region VII, Kansas City Office  
Milo Cress, Bridge Engineer, Nebraska Division Office

### University of Nebraska-Lincoln

Tom Grady, Electronic Technician

## ABSTRACT

One full-scale vehicle crash test was conducted on the Nebraska Turned-Down Approach Terminal Section. Test NETD-1 was conducted with a 1984 Dodge Colt weighing 1,887-lbs (test inertial). Impact conditions were 59.0 mph and 0 degrees with a 1.25-ft offset toward the roadway.

The test was conducted and reported in accordance with the requirements specified in the *Recommended Procedures for the Safety Performance Evaluation of Highway Appurtenances*, National Cooperative Highway Research Program (NCHRP) Report No. 230. The safety performance of the Nebraska Turned-Down Approach Terminal Section was determined to be unacceptable according to the NCHRP 230 criteria.



## TABLE OF CONTENTS

|  | Page |
|--|------|
| DISCLAIMER STATEMENT . . . . .                                       | i    |
| ACKNOWLEDGEMENTS . . . . .   | ii   |
| ABSTRACT . . . . .   | iii  |
| TABLE OF CONTENTS . . . . .  | v    |
| List of Figures . . . . .  | vii  |
| List of Tables . . . . .   | viii |
| 1 INTRODUCTION . . . . .   | 1    |
| 1.1 Problem Statement . . . . .                                      | 1    |
| 1.2 Objective . . . . .  | 1    |
| 1.3 Scope . . . . .  | 1    |
| 2 BACKGROUND . . . . .   | 3    |
| 3 TEST CONDITIONS . . . . .  | 7    |
| 3.1 Test Facility . . . . .  | 7    |
| 3.1.1 <u>Test Site</u> . . . . .                                     | 7    |
| 3.1.2 <u>Vehicle Tow System</u> . . . . .                            | 7    |
| 3.1.3 <u>Vehicle Guidance System</u> . . . . .                       | 7    |
| 3.2 Nebraska Turned Down Guardrail Terminal Design Details . . . . . | 10   |
| 3.3 Test Vehicle . . . . .   | 14   |
| 3.4 Data Acquisition Systems . . . . .                               | 18   |
| 3.4.1 <u>Accelerometers</u> . . . . .                                | 18   |
| 3.4.2 <u>High Speed Photography</u> . . . . .                        | 18   |
| 3.4.3 <u>Speed Trap Switches</u> . . . . .                           | 21   |
| 4 PERFORMANCE EVALUATION CRITERIA . . . . .                          | 23   |
| 5 TEST RESULTS . . . . .   | 25   |
| 5.1 TEST NETD-1 (2,042-lb, 59.0 mph, 0 deg) . . . . .                | 25   |
| 6 CONCLUSIONS . . . . .  | 39   |
| 7 DISCUSSION AND RECOMMENDATIONS . . . . .                           | 41   |
| 8 REFERENCES . . . . .   | 43   |

|   |    |
|---|----|
| 9 APPENDICES . . . . .                                    | 45 |
| APPENDIX A. ACCELEROMETER DATA ANALYSIS, NETD-1 . . . . . | 47 |
| APPENDIX B. RELEVANT CORRESPONDENCE . . . . .             | 55 |



## List of Figures

|   | Page |
|---|------|
| 1. Cable Tow and Guidance System . . . . .                            | 8    |
| 2. Tow Vehicles and Fifth Wheel . . . . .                             | 9    |
| 3. Turned-Down Approach Terminal Section Design Details . . . . .     | 11   |
| 4. Turned-Down Approach Terminal Section . . . . .                    | 12   |
| 5. Plan View of Installation . . . . .                                | 13   |
| 6. Guardrail Connection Detail, Post No. 3 . . . . .                  | 15   |
| 7. Test Vehicle, NETD-1 . . . . .                                     | 16   |
| 8. Vehicle Dimensions, Test NETD-1 . . . . .                          | 17   |
| 9. Flow Chart of Accelerometer Data Acquisition System . . . . .      | 19   |
| 10. Layout of High Speed Cameras, Test NETD-1 . . . . .               | 20   |
| 11. Impact Location, Test NETD-1 . . . . .                            | 26   |
| 12. Test Results and Sequential Photographs, Test NETD-1 . . . . .    | 27   |
| 13. Downstream Parallel Sequential Photographs, Test NETD-1 . . . . . | 28   |
| 14. Traffic-Side Sequential Photographs, Test NETD-1 . . . . .        | 29   |
| 15. Full-Scale Vehicle Crash Test, Test NETD-1 . . . . .              | 30   |
| 16. Full-Scale Vehicle Crash Test, Test NETD-1 (con't) . . . . .      | 31   |
| 17. Vehicle Damage, Test NETD-1 . . . . .                             | 32   |
| 18. Vehicle Damage, Test NETD-1 (con't) . . . . .                     | 33   |
| 19. Interior Vehicle Deformations, Test NETD-1 . . . . .              | 34   |
| 20. Turned-Down Terminal Section Damage, Test NETD-1 . . . . .        | 36   |
| 21. Damage at Post No. 1, Test NETD-1 . . . . .                       | 37   |
| 22. Shear Bolt Failure at Post No. 3, Test NETD-1 . . . . .           | 38   |

## List of Tables

|  |    |
|--|----|
| 1. Full-Scale Crash Testing Matrix and Evaluation Criteria . . . . . | 23 |
| 2. NCHRP Report 230 Evaluation Criteria . . . . .                    | 24 |
| 3. Summary of Safety Performance Results . . . . .                   | 40 |

# 1 INTRODUCTION

## 1.1 Problem Statement

For many years, the Nebraska Department of Roads (NDOR) has constructed turned-down approach terminal sections on the upstream ends of standard W-beam guardrails to prevent the spearing effect of blunt end guardrails into errant vehicles.

In 1989, the Midwest Roadside Safety Facility (MwRSF), in conjunction with the NDOR, modified the guardrail release mechanism as a result of a series of static pull-down tests conducted on an actual field installation (1). This modification was intended to prevent the guardrail from collapsing due to fluctuations in temperature and vibrations from passing trucks. At that time, it was determined that no full-scale vehicle crash tests were required on the design modification.

However, in recent years, the Federal Highway Administration (FHWA) has prohibited the use of all turned-down approach terminal sections as an acceptable end treatment on high-speed and high-volume highways. Since hundreds of turned-down approach terminal sections exist in Nebraska, the NDOR desired to verify the acceptance of existing as well as new turned-down end treatments.

## 1.2 Objective

The objective of the research project was to conduct a safety performance evaluation on the Nebraska Turned-Down Approach Terminal Section according to the National Cooperative Highway Research Program Report No. 230 (2).

## 1.3 Scope

One full-scale vehicle crash test (Test NETD-1) was conducted with an 1,800-lb minicompact sedan at the target conditions of 60 mph and 0 degrees with a 1.25-ft offset toward

the roadway (NCHRP 230 Test Designation No. 45). The original test matrix included three full-scale vehicle crash tests (NCHRP 230 Test Designation Nos. 41, 44, and 45). From the literature review on the testing of turned-down approach terminal sections, Test Designation No. 45 was found to be the most stringent test in the test matrix (Table 1), thus it was conducted first. Following an unacceptable safety performance evaluation of Test NETD-1, the remaining two tests were not conducted.

## 2 BACKGROUND

Standard W-beam guardrails have been extensively used along highways and roadways for many years. In its early use, the standard end treatment for the W-beam rail consisted of a blunt end which often pierced the occupant compartment of errant vehicles. In the late 1950s and early 1960s, state highway department engineers began to recognize the dangers of guardrail ends.

In the 1960s, the Oklahoma State Highway Department began to turn down and anchor the ends of the W-beam guardrail. This modification eliminated the piercing of the W-beam guardrail into vehicles and also developed the guardrail tensile strength necessary for effective vehicle redirection. In general, the turned-down guardrail provided excellent in-service performance for oblique as well as head-on impacts (3).

However, it was later discovered that the turned-down guardrail treatment could launch an impacting vehicle, causing it to roll over. In the late 1960s, this discovery was substantiated by tests conducted on the "Texas Twist" at the California Division of Highways (4) and at the Southwest Research Institute (5).

In 1976, the Texas State Department of Highways and Public Transportation and the Texas Transportation Institute (TTI) conducted a research study to modify the turned-down guardrail to eliminate the undesirable vehicle ramping and rollover behavior (6). This modification consisted of using clips made of mild-steel strap (1/8-in. x 3/4-in. x 8-in.). The clips were used to mount the W-beam to standard W-section backup plates bolted to the first five posts. The Texas Nested design used 7-in. diameter wood posts with a W-beam mounted at 27-in. as measured from the ground to the top of rail.

In 1979 and 1980, the Maryland State Highway Administration and TTI conducted a research study to modify the State of Maryland's turned-down design (7). The modification consisted of using clips made of mild-steel strap (1/8-in. x 3/4-in. x 8-in.). The clips were used to mount the W-beam to standard W-section backup plates bolted to the first six posts. The Maryland design used W6 x 8.5 steel posts and blockouts with a W-beam mounted at 27-in. as measured from the ground to the top of rail.

In 1981, the Oklahoma Department of Transportation and TTI conducted a research study to modify the State of Oklahoma's turned-down design (3). The modification consisted of using clips made of mild-steel strap (1/8-in. x 3/4-in. x 8-in.). The clips were used to mount the W-beam to standard W-section backup plates bolted to the first eight posts. The Oklahoma design used 6-in. x 8-in. wood posts with a W-beam mounted at 29-in. as measured from the ground to the top of rail. The first eight posts had 2-in. diameter holes drilled (parallel to roadway) in the 8-in. side at a maximum of 4-in. above the ground line.

From 1979 to 1983, a research study was conducted by ENSCO, INC., to develop safety modifications for turned-down guardrail terminals (8,9). The results of this research study lead to the development of the Controlled Releasing Terminal (CRT). The CRT design consisted of a 26-ft 10 1/2-in. straight, sloped terminal segment constructed from a twisted, 12 gauge steel C-rail. The first ten posts of the system were 6-in. x 8-in. wooden posts modified to breakaway. Two 3 1/2-in. diameter holes were drilled in the 8-in. side, one located at ground level while the second was located 16 inches below grade. The remainder of the posts were manufactured from steel. The first twelve posts of the design were configured with breakaway attachments to allow the rail to drop freely to the ground when impacted from the end.

In 1982, the Maryland State Highway Administration and TTI continued the research effort to develop a new "turned-down end" treatment (10). The original research study (7) was conducted in accordance with Transportation Research Circular No. 191 (11). However, with the publication of the new crash testing requirements in the National Cooperative Highway Research Program Report No. 230 (2), an 1800-lb test vehicle was added to the test matrix. This created a more stringent test to be conducted in the safety performance evaluation.

The final Maryland design consisted of a twisted terminal end section manufactured of an A36 flat steel rail (1/4-in. x 12 1/4-in. x 25-ft) (10). The first two posts (spaced at 12-ft 6-in.) of the installation were 6-in. x 8-in. timber posts with a 2-in. diameter hole drilled at ground level in the 8-in. side. The W-beam rail section was clamped to the W-section backup plates at the wooden posts. The remaining posts were W6 x 8.5 steel posts. The W-beam rail section was also clamped to the first three steel posts with attached W-section backup plates.

For many years, the Nebraska Department of Roads had used a turned-down guardrail terminal which incorporated a mild-steel clip (1/8-in. x 3/4-in. x 9-in.) to support the W-beam against the W-section backup plates mounted to the 6-in. x 8-in. timber posts. The clips were placed at the first five timber posts. However, maintenance crews discovered that after the clips had been exposed to temperature fluctuations and vibrations from passing traffic, the guardrail dropped to the ground with no impact ever occurring, rendering the end treatment ineffective.

In the summer of 1988, researchers at the Civil Engineering Department of the University of Nebraska modified the turned-down design used by the NDOR (1). A series of static tests were conducted on a variety of release mechanisms which incorporated clips, bolts, and combinations of clips and bolts at different post locations. From the results of the static tests, researchers recommended the placement of #10 bolts in the W-beam at Post Nos. 3 and 5, with no steel clips at any of the posts. Test NETD-1 was conducted on this design.





### 3 TEST CONDITIONS

#### 3.1 Test Facility

##### 3.1.1 Test Site

The testing facility is located at the Lincoln Air-Park on the NW end of the Lincoln Municipal Airport. The test facility is approximately 5 mi. NW of the University of Nebraska-Lincoln. The site is surrounded and protected by an 8-ft high chain-link security fence.

##### 3.1.2 Vehicle Tow System

A reverse cable tow with a 1:2 mechanical advantage was used to propel the test vehicle. The distance traveled and the speed of the tow vehicle are one-half that of the test vehicle. A sketch of the cable tow system is shown in Figure 1. The test vehicle is released from the tow cable before impact with the bridge rail. The tow vehicle and the attached fifth-wheel are shown in Figure 2. The fifth wheel, built by the Nucleus Corporation, was used in conjunction with a digital speedometer to increase the accuracy of the test vehicle impact speed.

##### 3.1.3 Vehicle Guidance System

A vehicle guidance system developed by Hinch (12) was used to steer the test vehicle. The guidance system is shown in Figure 1. A guide flag attached to the front left wheel and the guide cable was sheared off before impact. The 3/8-in. diameter guide cable was tensioned to 3,000 lbs, and supported laterally and vertically every 100 ft by hinged stanchions. The hinged stanchions stood upright while holding up the guide cable, but as the vehicle was towed down the line, the guide-flag struck and knocked each stanchion to the ground. The vehicle guidance system was 1,500-ft long for both tests.

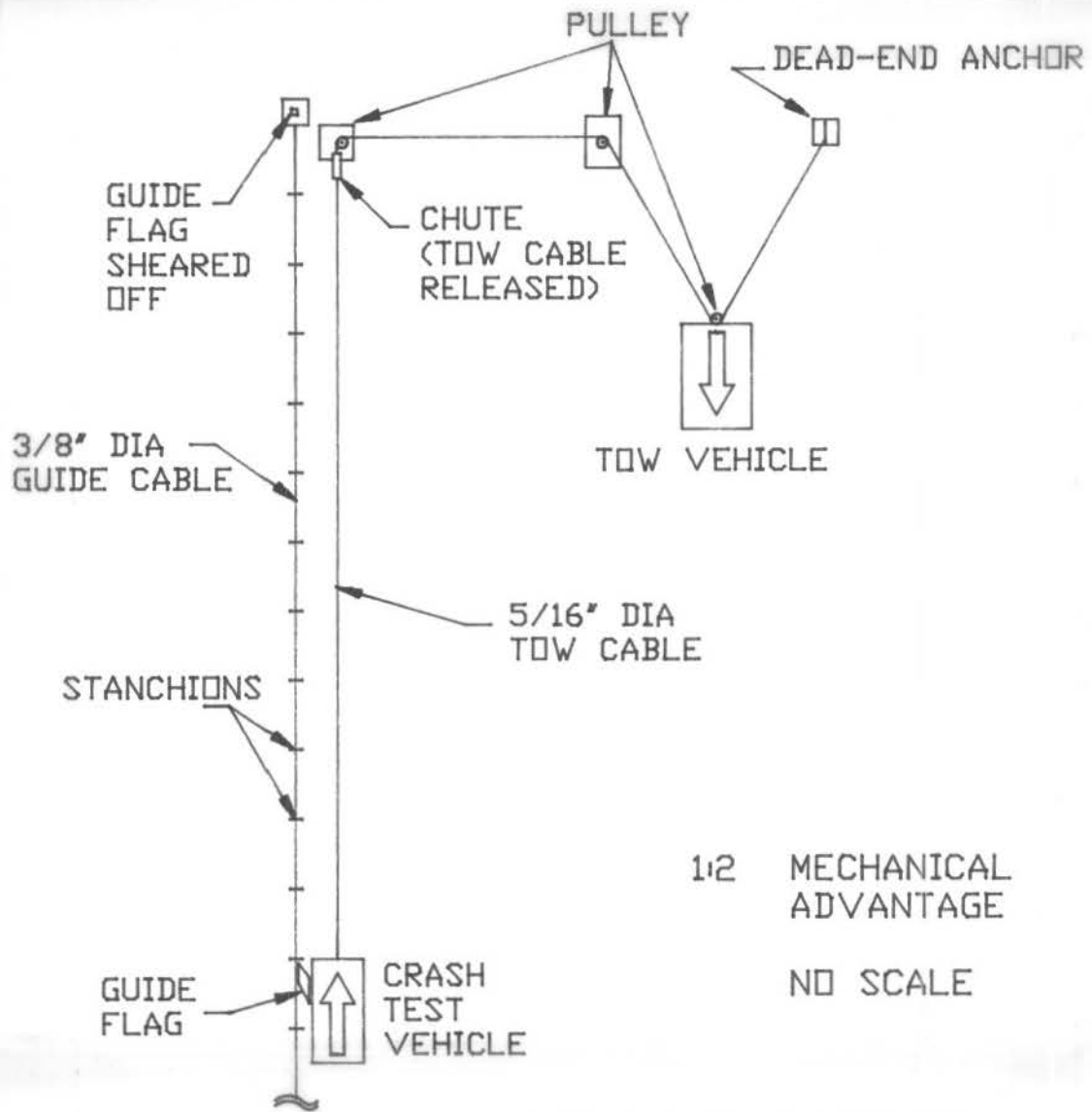

FIGURE 1. Cable Tow and Guidance System



**FIGURE 2.** Tow Vehicles and Fifth Wheel

### 3.2 Nebraska Turned Down Guardrail Terminal Design Details

A detailed drawing of the Nebraska Turned-Down Approach Terminal Section is shown in Figure 3. Photographs of the actual installation are shown in Figure 4. The total installation length was 100-ft (Figure 5). The post numbers shown on NDOR's standard design details (Figure 3) were not followed; instead, the posts were numbered in ascending order beginning at the upstream end (Figure 5). The installation consisted of three major structural components: (1) turned-down approach terminal section; (2) timber posts; (3) W-beam guardrail; and (4) back-up plates.

The turned-down approach terminal section was 25-ft long (Figures 3 and 4). The terminal section was constructed with 12 gauge W-beam guardrail which was twisted approximately 270 deg in the field in order to obtain a 90 degree permanent set rotation. The upstream end of the terminal section was anchored into the soil with a galvanized A36 steel anchor post assembly which was cast into a reinforced concrete footing (Figure 3). In addition, a Michigan end shoe was attached to the turned-down guardrail section at the top of the anchor post assembly.

The total installation was constructed with thirteen timber posts (Figure 5). The post holes were augered, and the posts were placed in the holes and tamped with a pneumatic tamper. Post Nos. 1 through 11 and Post Nos. 12 through 13 measured 6-in. x 8-in. x 6-ft, and 5 1/2-in. x 7 1/2-in. x 3-ft 7-in., respectively. Post Nos. 1 through 4 and Post Nos. 12 and 13 were drilled with a 2 3/8-in. diameter hole at a location 25-in. below the top of the post in the 8-in. and 7 1/2-in. side, respectively. In addition, a timber spacer block measuring 6-in. x 8-in. x 14-in. was attached to Post Nos. 1 through 11. Post Nos. 1 through 13 were spaced at 6-ft 3-in. on centers. The soil type was a native "silty clay" topsoil. The soil was not in conformance with



**FIGURE 4.** Turned-Down Approach Terminal Section

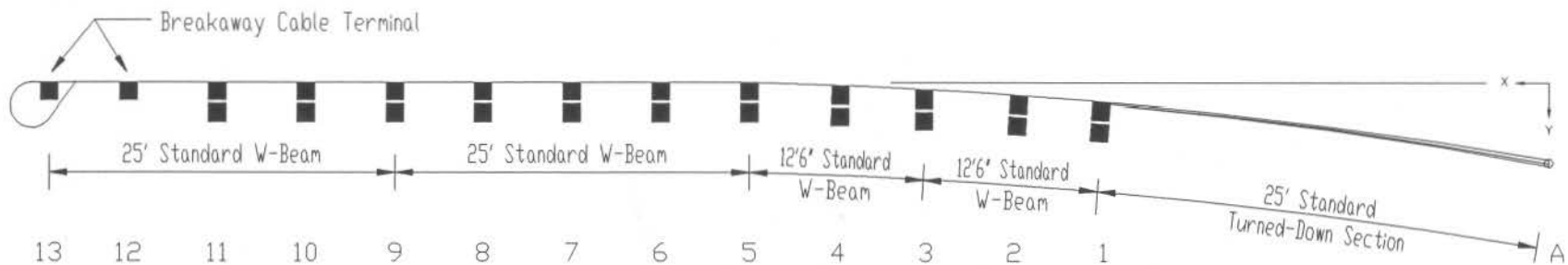

13

Posts

- Post No.'s 1 through 4: Breakaway Posts (6"x8"x6'-0" with a 2 3/8" hole drilled 25" from top of post)
- Post No.'s 5 through 11: Standard Posts (6"x8"x6'-0")
- Post No.'s 12 and 13: BCT Posts (5 1/2"x7 1/2"x3'-7" with a 2 3/8" hole drilled 25" from top of post)

Guardrail

- 2 - 25' Standard W-Beam Sections (12 Gauge)
- 2 - 12'-6" Standard W-Beam Sections (12 Gauge)
- 1 - 25' Standard W-Beam Section, Twisted 270 deg (12 Gauge)

Backup Plates

- 1 - 6' long W-Beam (12 Gauge) @ Post No. 5
- 4 - 12' long W-Beam (12 Gauge) @ Post No.'s 1 through 4
- 5 - 12' long W-Beam (12 Gauge) @ Post No.'s 6 through 8 and 10 through 11

Terminal Anchor Post

see Approach Terminal Section Special Plan C

| Post Location | X (ft.) | Y (ft.) |
|---------------|---------|---------|
| A             | 00.00   | 2.91    |
| 1             | 25.00   | 2.07    |
| 2             | 31.25   | 1.71    |
| 3             | 37.50   | 1.46    |
| 4             | 43.75   | 1.30    |
| 5             | 50.00   | 1.25    |
| 6             | 56.25   | 1.25    |
| 7             | 62.50   | 1.25    |
| 8             | 68.75   | 1.25    |
| 9             | 75.00   | 1.25    |
| 10            | 81.25   | 1.25    |
| 11            | 87.50   | 1.25    |
| 12            | 93.75   | 0.58    |
| 13            | 100.00  | 0.58    |

**FIGURE 5. Plan View of Installation**

either the strong soil (S-1) or the weak soil (S-2) defined in NCHRP 230 (2). The decision to deviate from the recommended testing procedures in NCHRP 230 was made to evaluate the appurtenance under typical soil conditions encountered in Nebraska.

Twelve gauge W-beam guardrail sections were used at all remaining locations of the installation. W-section backup plates were mounted on Post Nos. 1 through 8 and Post Nos. 10 and 11 (Figure 5). A 6-in. long backup plate was placed at Post No. 5, while all remaining backup plates were 12-in. long. The W-beam guardrail was not connected to Post Nos. 1 through 5. The guardrail was bolted to the backup plates at Post Nos. 1 and 3 with a No. 10 bolt (Figure 3 and 6).

### 3.3 Test Vehicle

The test vehicle used for Test NETD-1 was a 1984 Dodge Colt. The test vehicle had a test inertial and a gross static weight of 1,887-lb and 2,042-lb, respectively. The test vehicle is shown in Figure 7 and the vehicle dimensions are shown in Figure 8.

The suspension method (13) was used to calculate the vertical component of the center of gravity for the test vehicle. This method is based on the principle that the center of gravity of any freely suspended body is in the vertical plane through the point of suspension. The vehicle was suspended successively in three positions, and the respective planes containing the center of gravity were established. The intersection of these planes pinpointed the location of the center of gravity. The longitudinal component of the center of gravity was determined by using the axle weights of the vehicles.

Six 12-in. square, black and white-checked targets were placed on the vehicle. These targets were used in the high-speed film analysis. Two targets were located on the center of gravity, one on the top and one on the driver's side of the test vehicle. The remaining targets

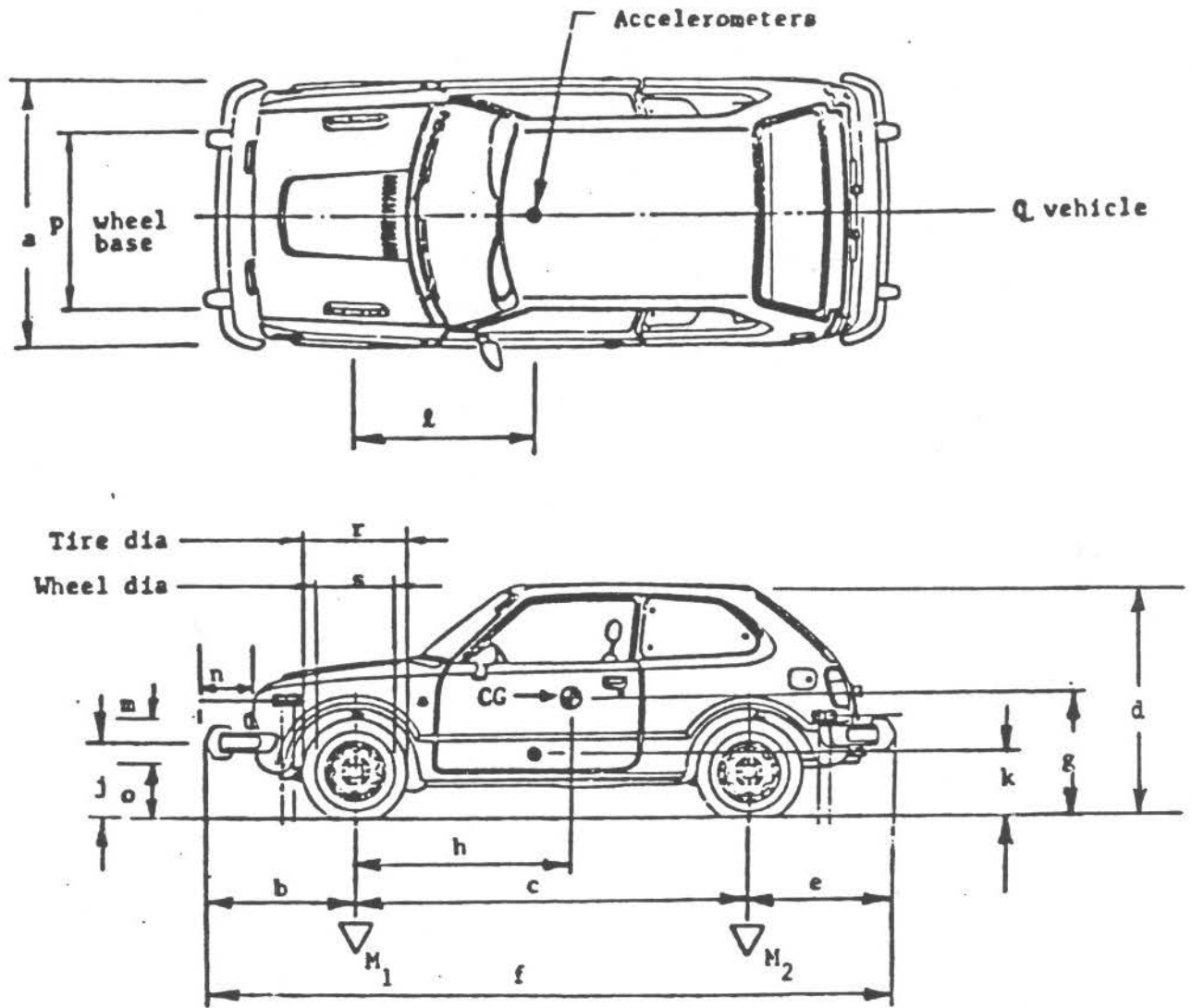

FIGURE 6. Guardrail Connection Detail, Post No. 3





**FIGURE 7.** Test Vehicle, NETD-1



**Geometry - in. (in.)**

|   |       |   |        |   |      |   |       |   |      |
|---|-------|---|--------|---|------|---|-------|---|------|
| a | 60.5  | d | 52.0   | j | 18.5 | m | 4.5   | p | 54.5 |
| b | 29.0  | e | 31.0   | k | 17.0 | n | 2.5   | r | 22.5 |
| c | 90.75 | f | 150.75 | l | 34.0 | o | 16.25 | s | 14.0 |

| <b>Mass - lb (kg)</b> | <b>Curb</b> | <b>Test Inertial*</b> | <b>Gross Static**</b> |
|-----------------------|-------------|-----------------------|-----------------------|
| M <sub>1</sub>        | 1045        | 1201                  | 1284                  |
| M <sub>2</sub>        | 530         | 686                   | 768                   |
| M <sub>T</sub>        | 1575        | 1887                  | 2042                  |
| h - in. (m)           | 30.5        | 33.0                  | 34.0                  |
| g - in. (m)           | 21.0        | 20.5                  | 20.0                  |

Test NETD-1  
1984 Dodge Colt (Silver)

**FIGURE 8. Vehicle Dimensions, Test NETD-1**

were located for reference so that they could be viewed from all three cameras. The front wheels of the test vehicle were aligned for camber, caster, and toe-in values of zero so that the vehicle would track properly along the guide cable. Two 5B flash bulbs were mounted on the roof of the vehicle to pinpoint the time of impact with the bridge rail on the high-speed film. The flash bulbs were fired by a pressure tape switch mounted on the front face of the bumper.

### **3.4 Data Acquisition Systems**

#### **3.4.1 Accelerometers**

Four triaxial piezoresistive accelerometers with a range of  $\pm 200$  g's (Endevco Model 7264) were used to measure the acceleration in the longitudinal and the lateral directions of the test vehicle. Two accelerometers were mounted in each of the two directions. The accelerometers were rigidly attached to a metal block mounted at the center of gravity.

The signals from the accelerometers were received and conditioned by an onboard vehicle Metraplex Unit. The multiplexed signal was then transmitted to the Honeywell 101 Analog Tape Recorder in the control van. A flow chart of the accelerometer data acquisition system is shown in Figure 9. State-of-the-art computer software, "Computerscope" was used to acquire the accelerometer data onto a Cyclone 386/16 MHz computer with a high-speed data acquisition board; "DSP" was used to analyze and plot the accelerometer data on a PC Brand 486/33 MHz computer.

#### **3.4.2 High Speed Photography**

Three high-speed 16-mm cameras, with operating speeds of approximately 500 frames/sec, were used to film the crash tests. The overhead camera was a Red Lake Locam with a wide-angle 12.5-mm lens. The parallel camera was a Photec IV with a 80-mm lens. The perpendicular camera was a Photec IV with a 55-mm lens. A schematic of all three camera

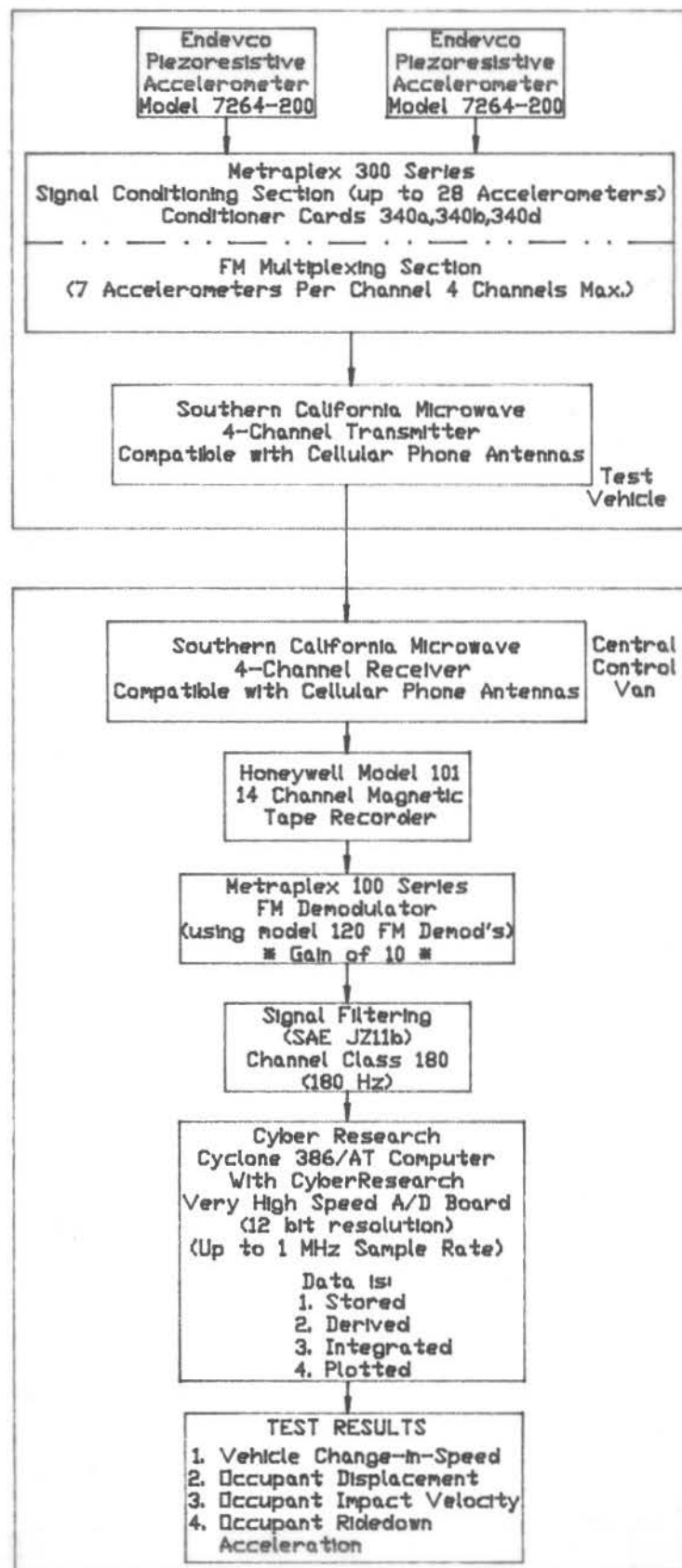
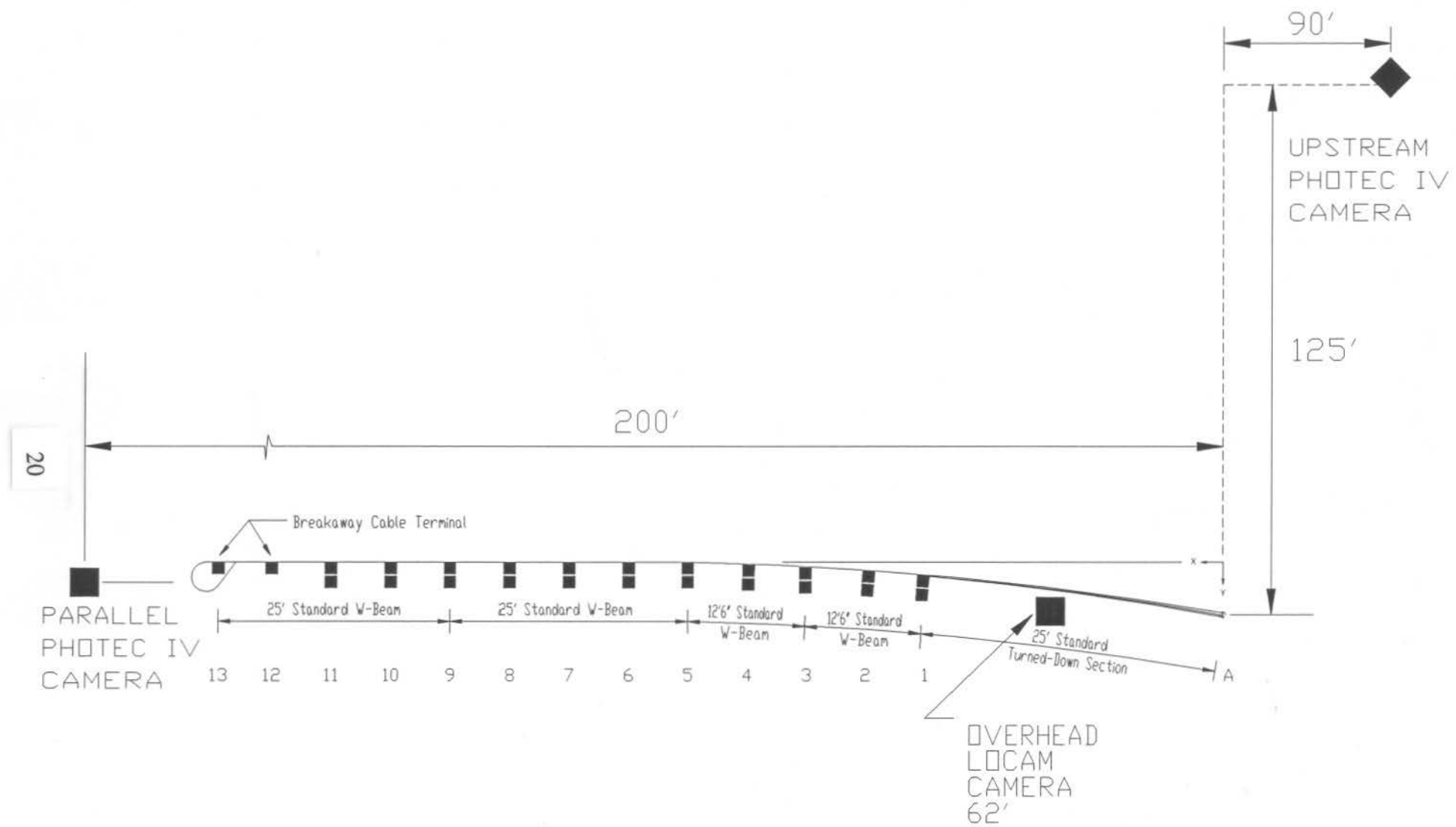

FIGURE 9. Flow Chart of Accelerometer Data Acquisition System



**FIGURE 10.** Layout of High Speed Cameras, Test NETD-1

locations for each test is shown in Figure 10. A 5-ft wide by 5-ft long grid was painted on the concrete surface behind the barrier. The white-colored grid was used to provide a visible reference system which could be used in the analysis of the overhead high-speed film. The film was analyzed using the Vanguard Motion Analyzer. Actual camera speed and camera divergence factors were considered in the analysis of the high-speed film.

#### 3.4.3 Speed Trap Switches

Eight tape pressure switches spaced at 5-ft intervals were used to determine the speed of the vehicle before and after impact. Each tape switch fired a strobe light as the left front tire of the test vehicle passed over it. The average speed of the test vehicle between the tape switches was determined by knowing the distance between pressure switches, the calibrated film speed, and the number of frames from the high speed film between flashes. In addition, the average speed was determined from electronic timing mark data (recorded with the oscilloscope software on the Cyclone computer) as the test vehicle passed over each tape switch.



#### 4 PERFORMANCE EVALUATION CRITERIA

The performance evaluation criteria used to evaluate the crash test was taken from NCHRP Report No. 230 (2). The test conditions for the required test matrix are shown in Table 1. The specific evaluation criteria are shown in Table 2. The safety performance of the Nebraska Turned-Down Approach Terminal Section was evaluated according to three major factors: (1) structural adequacy; (2) occupant risk; and (3) vehicle trajectory after collision. These three evaluation criteria are defined and explained in NCHRP 230. In addition, the turned-down approach terminal section with attached W-beam should readily activate in a predictable manner by dropping toward the ground during an head-on impact.

The vehicle damage was assessed by the traffic accident scale (TAD) (14) and the vehicle damage index (VDI) (15).

Table 1. Full-Scale Crash Testing Matrix and Evaluation Criteria

| Test No. | NCHRP 230 Designation No. | Test Vehicle (lb) | Impact Conditions |             | Impact Location                           | Evaluation Criteria |
|----------|---------------------------|-------------------|-------------------|-------------|---|---------------------|
|          |                           |                   | Speed (mph)       | Angle (deg) |   |                     |
| 1        | 41                        | 4,500             | 60                | 0           | Center nose of device                     | C,D,E,F,H,J         |
| 2        | 44                        | 1,800             | 60                | 15          | Midway between nose and length of need    | C,D,E,F,H,I,J       |
| 3        | 45                        | 1,800             | 60                | 0           | Offset 1.25 ft from center nose of device | C,D,E,F,H,J         |



Table 2. NCHRP Report 230 Evaluation Criteria

|  |   |                                       |  |                     |                |    |    |  |  |                     |                |    |
|--|---|---------------------------------------|--|---------------------|----------------|----|----|--|--|---------------------|----------------|----|
| Structural Adequacy                          | C. Acceptable test article performance may be by redirection, controlled penetration, or controlled stopping of the vehicle.  |                                       |  |                     |                |    |    |  |  |                     |                |    |
|  | D. Detached elements, fragments or other debris from the test article shall not penetrate or show potential for penetrating the passenger compartment or present undue hazard to other traffic.   |                                       |  |                     |                |    |    |  |  |                     |                |    |
| Occupant Risk                                | E. The vehicle shall remain upright during and after collision although moderate roll, pitching and yawing are acceptable. Integrity of the passenger compartment must be maintained with essentially no deformation or intrusion.  |                                       |  |                     |                |    |    |  |  |                     |                |    |
|  | <p>F. Impact velocity of hypothetical front seat passenger against vehicle interior, calculated from vehicle accelerations and 24 in. forward and 12 in. lateral displacements, shall be less than:</p> <table style="margin-left: auto; margin-right: auto;"> <tr> <td colspan="2" style="text-align: center;"><u>Occupant Impact Velocity - fps</u></td> </tr> <tr> <td style="text-align: center;"><u>Longitudinal</u></td> <td style="text-align: center;"><u>Lateral</u></td> </tr> <tr> <td style="text-align: center;">30</td> <td style="text-align: center;">20</td> </tr> </table> <p>and vehicle highest 10 ms average accelerations subsequent to instant of hypothetical passenger impact should be less than:</p> <table style="margin-left: auto; margin-right: auto;"> <tr> <td colspan="2" style="text-align: center;"><u>Occupant Ridedown Accelerations - g's</u></td> </tr> <tr> <td style="text-align: center;"><u>Longitudinal</u></td> <td style="text-align: center;"><u>Lateral</u></td> </tr> <tr> <td style="text-align: center;">15</td> <td style="text-align: center;">15</td> </tr> </table> | <u>Occupant Impact Velocity - fps</u> |  | <u>Longitudinal</u> | <u>Lateral</u> | 30 | 20 | <u>Occupant Ridedown Accelerations - g's</u> |  | <u>Longitudinal</u> | <u>Lateral</u> | 15 |
| <u>Occupant Impact Velocity - fps</u>        |   |                                       |  |                     |                |    |    |  |  |                     |                |    |
| <u>Longitudinal</u>                          | <u>Lateral</u>  |                                       |  |                     |                |    |    |  |  |                     |                |    |
| 30   | 20  |                                       |  |                     |                |    |    |  |  |                     |                |    |
| <u>Occupant Ridedown Accelerations - g's</u> |   |                                       |  |                     |                |    |    |  |  |                     |                |    |
| <u>Longitudinal</u>                          | <u>Lateral</u>  |                                       |  |                     |                |    |    |  |  |                     |                |    |
| 15   | 15  |                                       |  |                     |                |    |    |  |  |                     |                |    |
| Vehicle Trajectory                           | H. After collision, vehicle trajectory and final stopping position shall intrude a minimum distance, if at all, into adjacent traffic lanes.  |                                       |  |                     |                |    |    |  |  |                     |                |    |
|  | I. In test where the vehicle is judged to be redirected into or stopped while in adjacent traffic lanes, vehicle speed change during test article collision should be less than 15 mph and the exit angle from the test article should be less than 60 percent of the test impact angle, both measured at time of vehicle loss of contact with test device.   |                                       |  |                     |                |    |    |  |  |                     |                |    |
|  | J. Vehicle trajectory behind the test article is acceptable.  |                                       |  |                     |                |    |    |  |  |                     |                |    |

## 5 TEST RESULTS

### 5.1 TEST NETD-1 (2,042-lb, 59.0 mph, 0 deg)

Test NETD-1 was conducted with 1984 Dodge Colt under the impact conditions of 59.0 mph and 0 degrees (head-on) with respect to a line parallel to the roadway and offset 1.25-ft toward the roadway (Figure 11). A summary of the test results and sequential photographs are shown in Figure 12. Additional sequential photographs are shown in Figures 13 through 16.

After the initial impact with the Turned-Down Approach Terminal Section, the left-front tire came off the ground at approximately 0.036-sec as the vehicle rode up the twisted guardrail section. From 0.084-sec to 0.276-sec, the vehicle continued to travel upward along the twisted guardrail section. This action occurred in conjunction with the clockwise roll motion away from the guardrail. The left-front tire impacted Post No. 1 and blew out at approximately 0.344-sec. At 0.436-sec, the left-rear tire impacted Post No. 1 but did not blow out. The vehicle became airborne at approximately 0.480-sec. The front of the vehicle began to nosedive downward at 0.625-sec, and the right-front tire contacted the ground at approximately 0.700-sec. The friction between the ground and the right front corner of the vehicle caused the vehicle's rear end to rotate upward, hinged about the vehicle's front end. At 1.422-sec, the vehicle was near a vertical position with the front end downward. The vehicle continued to rotate, and at 1.938-sec, the left-rear corner of the vehicle contacted the ground. The vehicle again obtained a vertical position with the front end upward at approximately 2.797-sec. Subsequently, the vehicle dropped to the ground in an upright position and came to rest 127-ft downstream from impact and offset 14-ft laterally on the traffic-side from a line parallel to the traffic-side face of the guardrail.

Exterior vehicle damage is shown in Figures 17 and 18, while the interior vehicle deformations are shown in Figure 19. The majority of the vehicle damage occurred at three body



FIGURE 11. Impact Location, Test NETD-1



0.000-sec                      0.203-sec                      0.641-sec                      0.859-sec                      1.422-sec

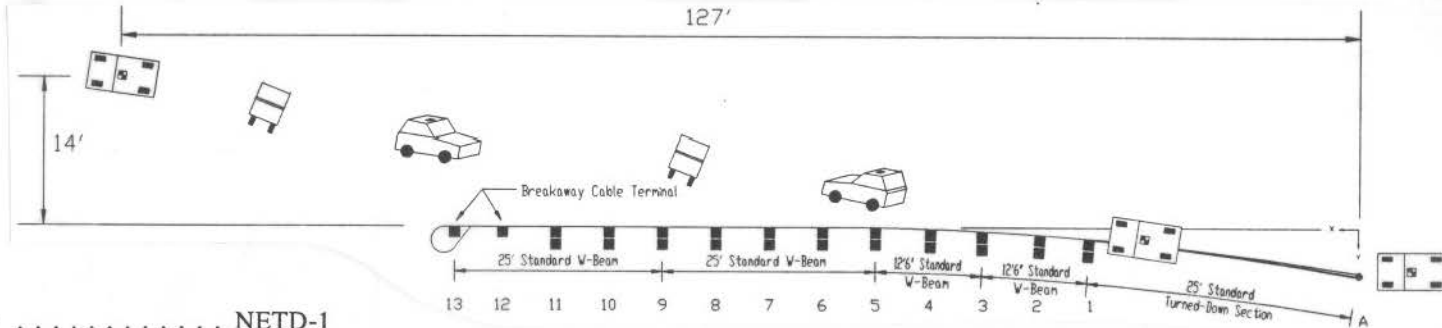

- Test Number ..... NETD-1
- Date ..... 3/13/92
- Appurtenance ..... Nebraska Turned-Down Approach Terminal Section and Guardrail
- Total Length ..... 100-ft
- Steel W-beam Guardrail
  - Mounting Height ..... 27-in.
  - Length-of-Need ..... 75-ft
  - Material Size ..... 12 Gauge
  - Terminal Section ..... 25-ft
  - Material Size ..... 12 Gauge
- Timber Posts
  - Post No.'s 1 - 11 ..... 6-in. x 8-in. x 6-ft
  - Post No.'s 12 - 13 ..... 5 1/2-in. x 7 1/2-in. x 3-ft 7-in.
- Timber Spacer Blocks
  - Post No.'s 1 - 11 ..... 6-in. x 8-in. x 1-ft 2-in.
- Soil Type ..... Silty-Clay (SL) (Dry)
- Vehicle
  - Model ..... 1984 Dodge Colt
  - Weight
    - Curb ..... 1,830-lb
    - Test Inertial ..... 1,887-lb
    - Gross Static ..... 1,887-lb

- Vehicle Speed
  - Impact ..... 59.0 mph
  - Exit ..... 50.0 mph
- Vehicle Angle
  - Impact ..... 0 deg
  - Exit ..... 13 deg
- Vehicle Snagging ..... Left-front undercarriage and tires at Post No. 1
- Vehicle Stability ..... Vehicle Rollover
- Occupant Ridedown Deceleration
  - Longitudinal ..... 16.7 g's > 15
  - Lateral ..... 22.5 g's > 15
- Occupant Impact Velocity
  - Longitudinal ..... 10.1 fps < 30
  - Lateral ..... 13.4 fps < 20
- Vehicle Damage ..... Extensive
  - TAD ..... RFQ-3, LBQ-6
  - VDI ..... RFE02, LBA06
- Vehicle Stopping Distance
  - Lateral ..... 14-ft
  - Longitudinal ..... 127-ft
- Guardrail Damage ..... Minor

FIGURE 12. Test Results and Sequential Photographs, Test NETD-1



0.000 sec



0.344 sec



0.670 sec



0.036 sec



0.418 sec



0.714 sec



0.084 sec



0.436 sec



0.800 sec



0.104 sec



0.462 sec



0.954 sec



0.196 sec



0.532 sec



0.276 sec



0.600 sec

FIGURE 13. Downstream Parallel Sequential Photographs, Test NETD-1



0.000 sec



0.547 sec



1.422 sec



0.062 sec



0.625 sec



1.828 sec



0.203 sec



0.641 sec



1.938 sec



0.375 sec



0.688 sec



2.328 sec



0.453 sec



0.781 sec



2.797 sec



0.516 sec



0.859 sec



3.219 sec

FIGURE 14. Traffic-Side Sequential Photographs, Test NETD-1



FIGURE 15. Full-Scale Vehicle Crash Test, Test NETD-1



FIGURE 16. Full-Scale Vehicle Crash Test, Test NETD-1 (con't)

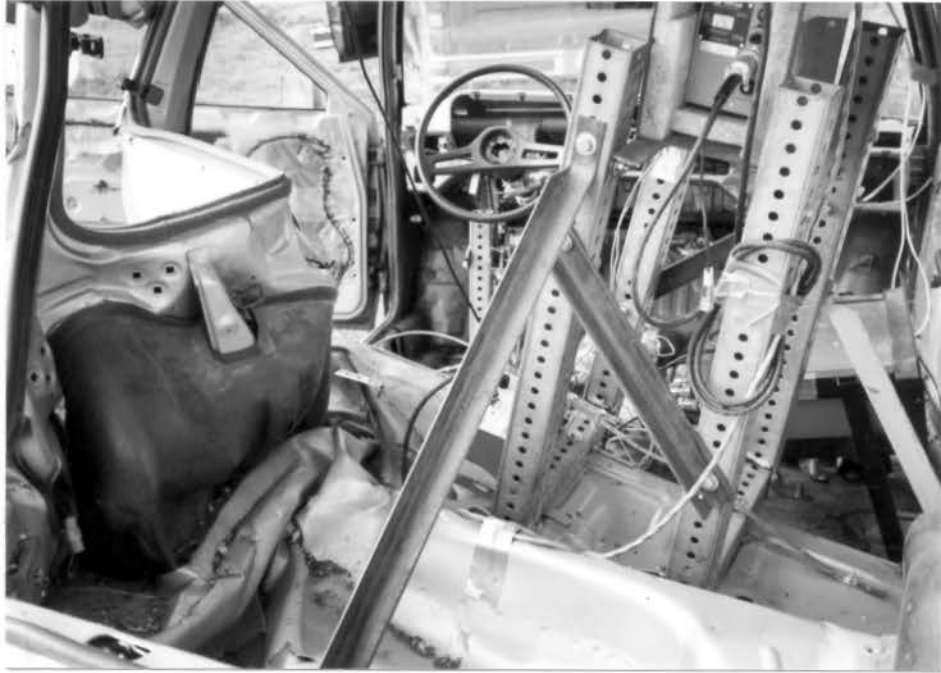



FIGURE 17. Vehicle Damage, Test NETD-1



**FIGURE 18.** Vehicle Damage, Test NETD-1 (con't)



**FIGURE 19.** Interior Vehicle Deformations, Test NETD-1

panel locations, the right-front quarter, the left-rear quarter, and the rear end. The right-front quarter damage occurred primarily to the fender, axle, and bumper. The left-rear quarter damage occurred primarily to fender (18-in. crush depth), undercarriage, axle, bumper, and hatchback. In addition, excessive interior deformations occurred at the left-side rear seat position as a result of the excessive, exterior left-rear quarter damage (Figure 19).

Guardrail damage is shown in Figures 20 through 22. The Michigan end shoe received dents, scrapes, and tire marks (Figure 20). Additional tire marks were evident on the surface of the twisted, 25-ft terminal section. Minor gouging was evident on the top of Post No. 1 and the attached spacer block (Figure 21). In addition, the spacer block was rotated approximately 85 deg clockwise in the direction of traffic (Figures 20 and 21). The back-up plate at Post No. 1 was also deformed. The shear bolts at Post Nos. 1 and 3 had also failed (Figures 21 and 22).

The longitudinal and lateral occupant impact velocities were determined to be 10.1 fps and 13.4 fps, respectively. The highest 0.010-sec average occupant ridedown decelerations in the longitudinal and lateral directions were 16.7 g's and 22.5 g's, respectively. The results of the occupant risk, determined from accelerometer data, are summarized in Figure 12. The results are shown graphically in Appendix A.



**FIGURE 20.** Turned-Down Terminal Section Damage, Test NETD-1



FIGURE 21. Damage at Post No. 1, Test NETD-1



**FIGURE 22.** Shear Bolt Failure at Post No. 3, Test NETD-1

## 6 CONCLUSIONS

The 1,887-lb (test inertial) full-scale vehicle crash test (Test Designation No. 45) on the Nebraska Turned-Down Approach Terminal Section proved to be unacceptable according to the safety performance criteria given in NCHRP 230 (2). The safety performance summary is presented in Table 3. The analysis of the test results revealed the following:

1. The test article did not safely redirect the vehicle.
2. No detached elements or fragments from the appurtenance penetrated the occupant compartment.
3. The vehicle did not remain upright both during and after impact.
4. The integrity of the occupant compartment was not maintained. The vehicle did receive excessive interior deformations due to vehicle rollover.
5. The occupant ridedown decelerations were determined to be unacceptable.
6. The occupant impact velocities were determined to be acceptable prior to vehicle rollover.
7. Vehicle trajectory and final stopping distance were determined to be acceptable.

The safety performance of the Nebraska Turned-Down Approach Terminal Section was determined to be unacceptable according to the criteria presented in Table 2. Based upon the failure of Test NETD-1, NDOR personnel determined that it would not be feasible to redesign the appurtenance to fit the needs of the department (Appendix B).



Table 3. Summary of Safety Performance Results

|                     |   |    |
|---------------------|---|----|
| Structural Adequacy | C. Acceptable test article performance may be by redirection, controlled penetration, or controlled stopping of the vehicle.  | U  |
|                     | D. Detached elements, fragments or other debris from the test article shall not penetrate or show potential for penetrating the passenger compartment or present undue hazard to other traffic.   | S  |
| Occupant Risk       | E. The vehicle shall remain upright during and after collision although moderate roll, pitching and yawing are acceptable. Integrity of the passenger compartment must be maintained with essentially no deformation or intrusion.  | U  |
|                     | <p>F. Impact velocity of hypothetical front seat passenger against vehicle interior, calculated from vehicle accelerations and 24 in. forward and 12 in. lateral displacements, shall be less than:</p> $\frac{\text{Occupant Impact Velocity - fps}}{\begin{matrix} \text{Longitudinal} \\ 30 \end{matrix} \qquad \begin{matrix} \text{Lateral} \\ 20 \end{matrix}}$ <p>and vehicle highest 10 ms average accelerations subsequent to instant of hypothetical passenger impact should be less than:</p> $\frac{\text{Occupant Ridedown Accelerations - g's}}{\begin{matrix} \text{Longitudinal} \\ 15 \end{matrix} \qquad \begin{matrix} \text{Lateral} \\ 15 \end{matrix}}$ | U  |
| Vehicle Trajectory  | H. After collision, vehicle trajectory and final stopping position shall intrude a minimum distance, if at all, into adjacent traffic lanes.  | S  |
|                     | I. In test where the vehicle is judged to be redirected into or stopped while in adjacent traffic lanes, vehicle speed change during test article collision should be less than 15 mph and the exit angle from the test article should be less than 60 percent of the test impact angle, both measured at time of vehicle loss of contact with test device.   | NA |
|                     | J. Vehicle trajectory behind the test article is acceptable.  | S  |

S - Satisfactory  
 U - Unsatisfactory  
 NA - Not Applicable

## 7 DISCUSSION AND RECOMMENDATIONS

The Nebraska Turned-Down Approach Terminal Section received an unsatisfactory safety performance evaluation based upon one full-scale vehicle crash test. The system contained a number of design inadequacies which contributed to the failure of the crash test. From the test results, three major design inadequacies were revealed.

First, the steel anchor post and attached Michigan end shoe projected above the ground in excess of 9-in. This structural component provided the initial ramping or launching effect on the vehicle which contributed to the vehicle rollover. In addition, the launched vehicle could not provide sufficient downward force on the rail to cause the rail to drop to the ground. Initial vehicle performance could be improved with the embedment of the anchor post, this has been successfully incorporated in similar designs.

Second, the turned-down section of the guardrail provided excessive flexural stiffness. This allowed the vehicle to continue to climb the turned-down section and begin to roll away from the guardrail toward the roadway. To remedy this situation, the turned-down section should instantaneously drop or bend toward the ground as the 1,800-lb vehicle passes over it, thus preventing vehicle uplift and roll motion.

The turned-down section need only be designed to resist the tensile forces transmitted from the guardrail's length-of-need during a redirective impact. Performance can be improved with the design of rail sections designed for tension only, (i.e. C-rail section, flat steel plate, or drilled W-beam section to reduce flexural strength). In previous testing with the C-rail and the flat steel plate (1/4-in. x 12 1/4-in.), performance was improved but remained unsatisfactory (8,9,10). A smaller flat steel plate, say 3/16-in. x 12-in., may improve performance.

Third, the release mechanism did not activate properly. This may have been due to the insufficient length over which the W-beam was allowed to release from its mounted position. The CRT design incorporated a guardrail release mechanism which extended over the length of twelve posts spaced at 6-ft 3-in. (8,9). This distance was found to be necessary for preventing vehicle uplift when impacted with an 1,800-lb vehicle. To further maintain vehicle stability, drilled holes should be provided in at least the first ten posts with diameters of approximately 3 1/2-in.

These modifications are given only in an effort to provide insight for future designs. They should not be used for final design. These recommendations can only be verified by full-scale vehicle crash testing.

## 8 REFERENCES

1. Pfeifer, B.G., Magdaleno, J.A., Faller, R.K., and Post, E.R., *Static Tests on Collapsing Guardrail Designs*, Transportation Report No. TRP-03-018-89, Final Report to the Nebraska Department of Roads, Civil Engineering Department, University of Nebraska-Lincoln, July 1989.
2. *Recommended Procedures for the Safety Performance Evaluation of Highway Appurtenances*, National Cooperative Highway Research Program Report No. 230, Transportation Research Board, Washington, D.C., March 1981.
3. Marquis, E.L., and Whitis, D., *Oklahoma W-Beam Roadside Barrier Terminal Section Tests*, Final Report to the Oklahoma Department of Transportation, Report No. FHWA/TX-81RF4166, Performing Agency: Texas Transportation Institute, Texas A&M University, April 1981.
4. Nordlin, E.F., Field, R.N., and Folsom, J.J., *Dynamic Tests of Short Sections of Corrugated Metal Beam Guardrail*, Highway Research Record No. 259, Highway Research Board, National Research Council, 1969.
5. Michie, J.D., and Bronstad, M.E., *Guardrail Performance: End Treatments*, Southwest Research Institute, August 1969.
6. Hirsch, T.J., Buth, C.E., Nixon, J.F., Hustace, D., and Cooner, H., *Eliminating Vehicle Rollovers on Turned-Down Guardrail Terminals*, Transportation Research Record No. 631, 1977.
7. Hirsch, T.J., and Dolf, T.J., *Maryland Turned-Down Guardrail Terminal*, Research Report No. AW080-237-046, Final Report to the Maryland Department of Transportation, Texas Transportation Institute, May 1980.
8. Hinch, J.A., Owings, R.P., and Manhard, G.A., *Safety Modifications of Turned-Down Guardrail Terminals - Final Report, Volume I - Executive Summary*, Report No. FHWA/RD-84/034, Federal Highway Administration, Washington, D.C., June 1984.
9. Hinch, J.A., Owings, R.P., and Manhard, G.A., *Safety Modifications of Turned-Down Guardrail Terminals - Final Report, Volume II - Technical Report*, Report No. FHWA/RD-84/035, Federal Highway Administration, Washington, D.C., June 1984.
10. Hirsch, T.J., and Arnold, A., *Maryland Turned-Down Guardrail Terminal*, Research Report No. AW082-237-046, Final Report to the Maryland Department of Transportation, Texas Transportation Institute, August 1982.

11. *Recommended Procedures for Vehicle Crash Testing of Highway Appurtenances*, Transportation Research Circular No. 191, Transportation Research Board, National Academy of Sciences, February 1978.
12. Hinch, J., Yang, T-L, and Owings, R., *Guidance Systems for Vehicle Testing*, ENSCO, Inc., Springfield, VA, 1986.
13. *Center of Gravity Test Code - SAE J874 March 1981*, SAE Handbook Vol. 4, Society of Automotive Engineers, Inc., Warrendale, Penn., 1986
14. *Vehicle Damage Scale for Traffic Investigators*, Traffic Accident Data Project Technical Bulletin No. 1, National Safety Council, Chicago, IL, 1971.
15. *Collision Deformation Classification, Recommended Practice J224 March 1980*, SAE Handbook Vol. 4, Society of Automotive Engineers, Warrendale, Penn., 1985.

## 9 APPENDICES



## APPENDIX A.

### ACCELEROMETER DATA ANALYSIS, NETD-1

Figure A-1 Sketch of Accelerometer Locations, Test NETD-1

Figure A-2 Graph of Longitudinal Deceleration, Acc. #1

Figure A-3 Graph of Vehicle Change in Speed, Acc. #1

Figure A-4 Graph of Longitudinal Occupant Displacement, Acc. #1

Figure A-5 Graph of Lateral Deceleration, Acc. #4

Figure A-6 Graph of Lateral Occupant Impact Velocity, Acc. #4

Figure A-7 Graph of Lateral Occupant Displacement, Acc. #4



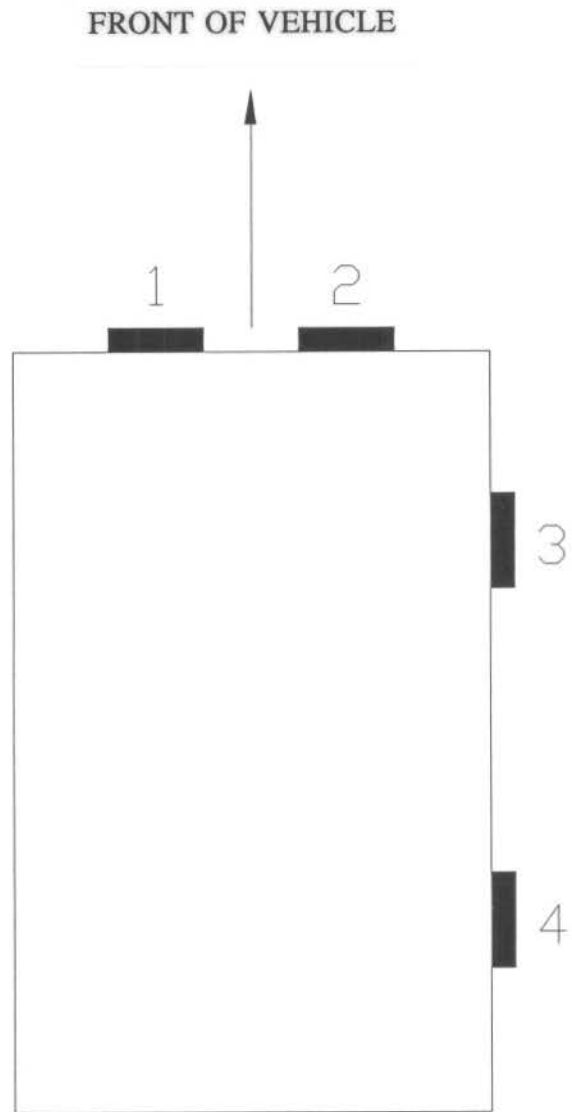

FIGURE A-1. SKETCH OF ACCELEROMETER LOCATIONS, TEST NETD-1

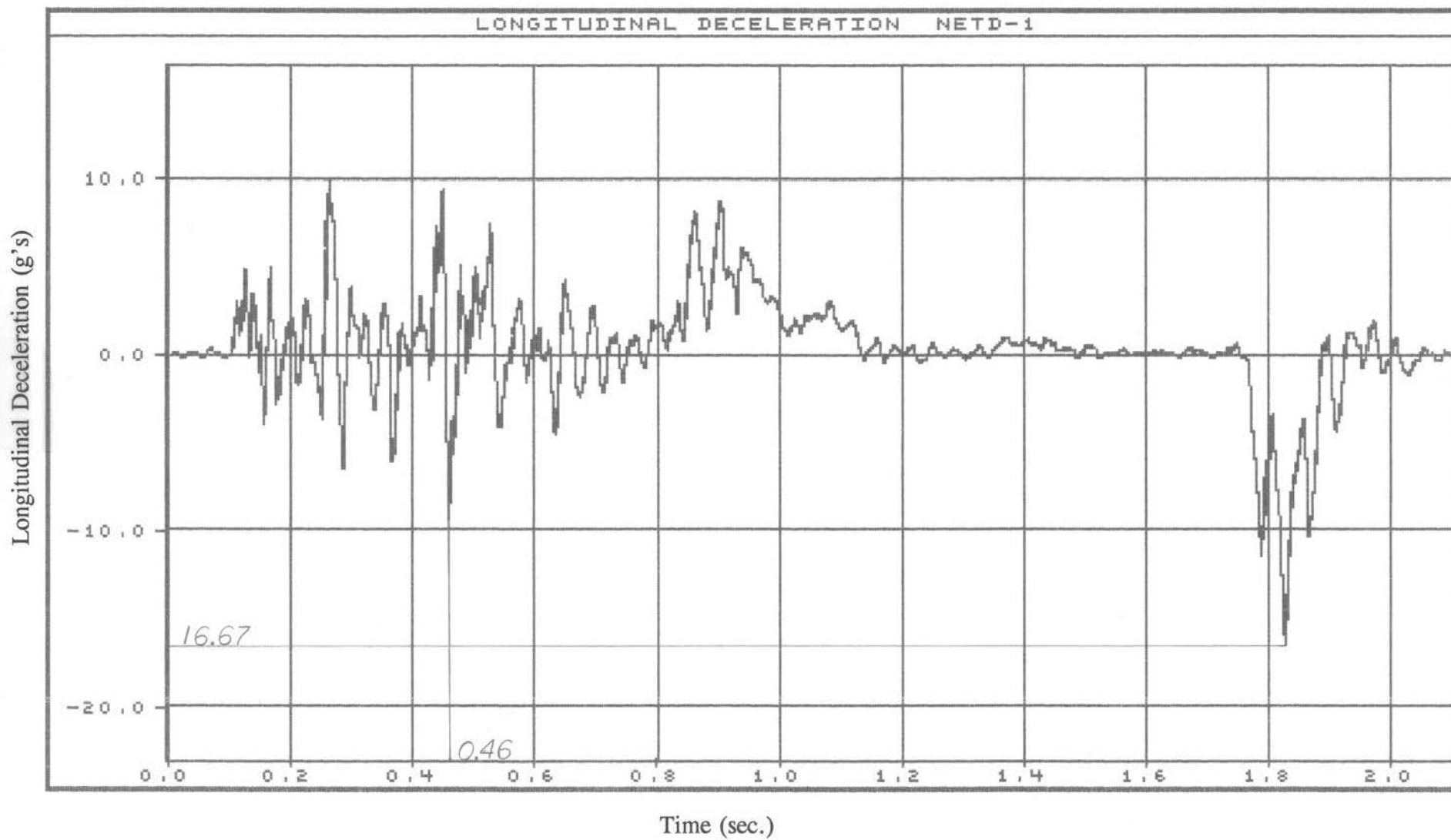

FIGURE A-2. GRAPH OF LONGITUDINAL DECELERATION, ACC. #1

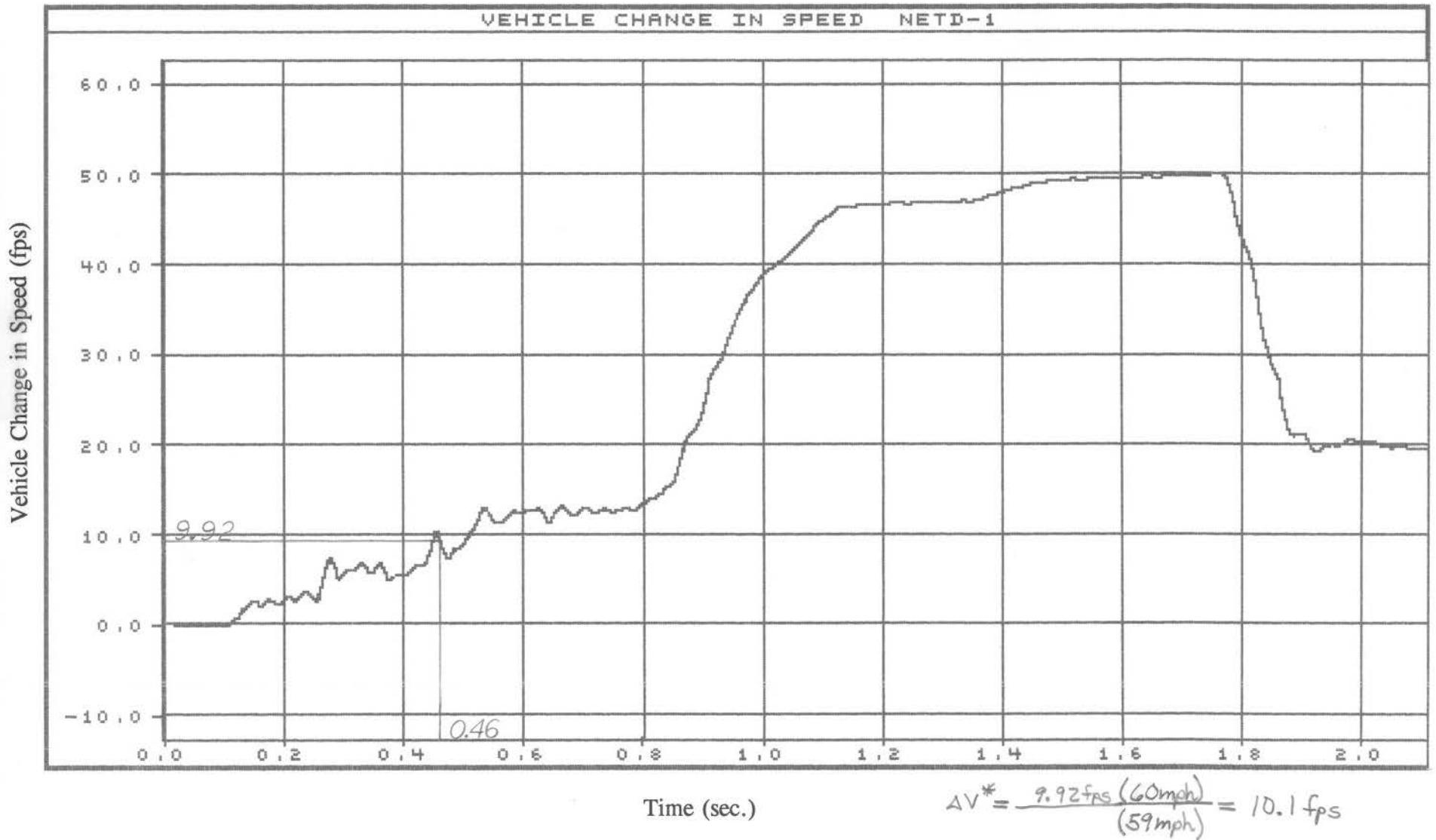

FIGURE A-3. GRAPH OF VEHICLE CHANGE IN SPEED, ACC. #1

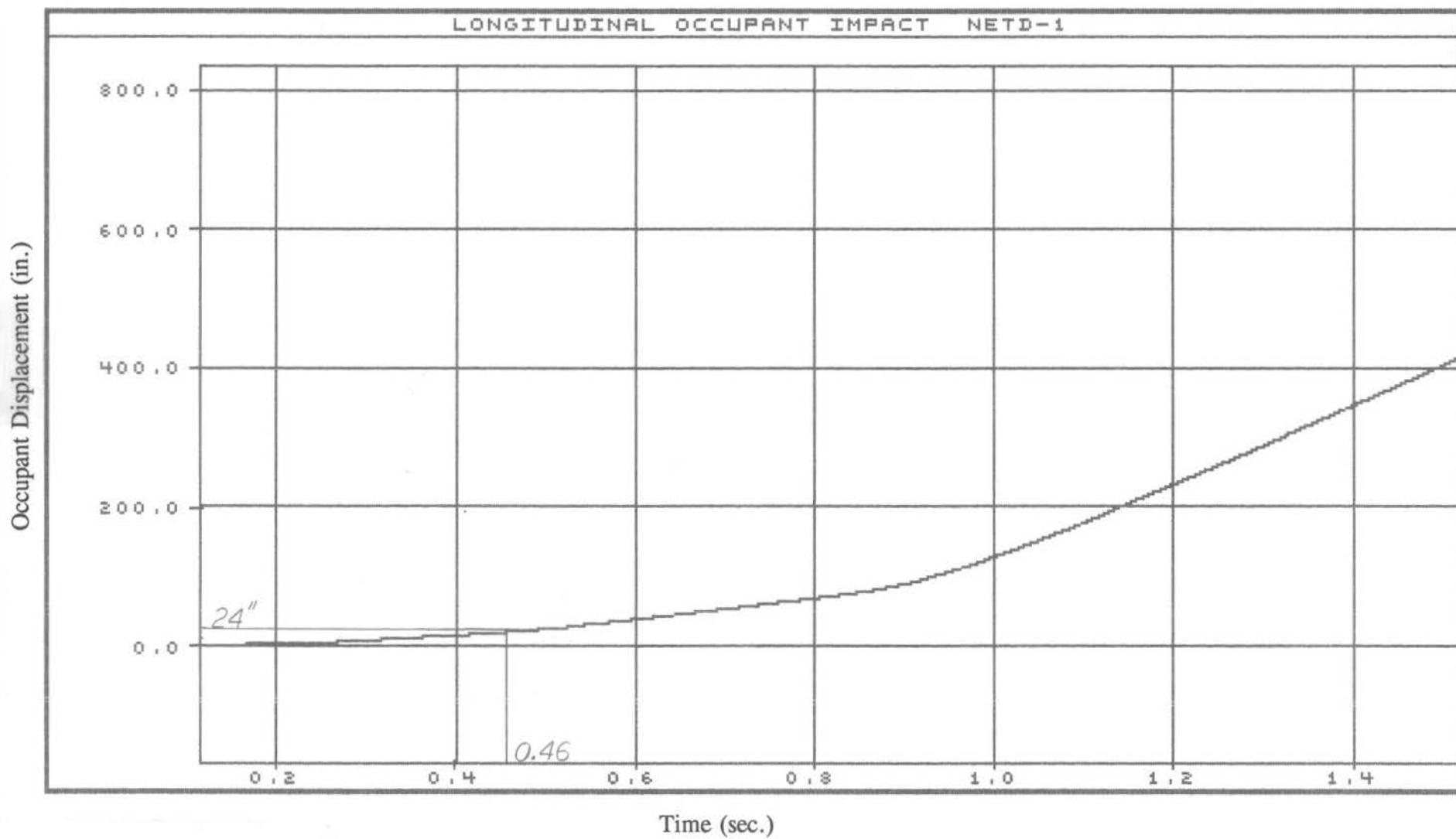

FIGURE A-4. GRAPH OF LONGITUDINAL OCCUPANT DISPLACEMENT, ACC. #1

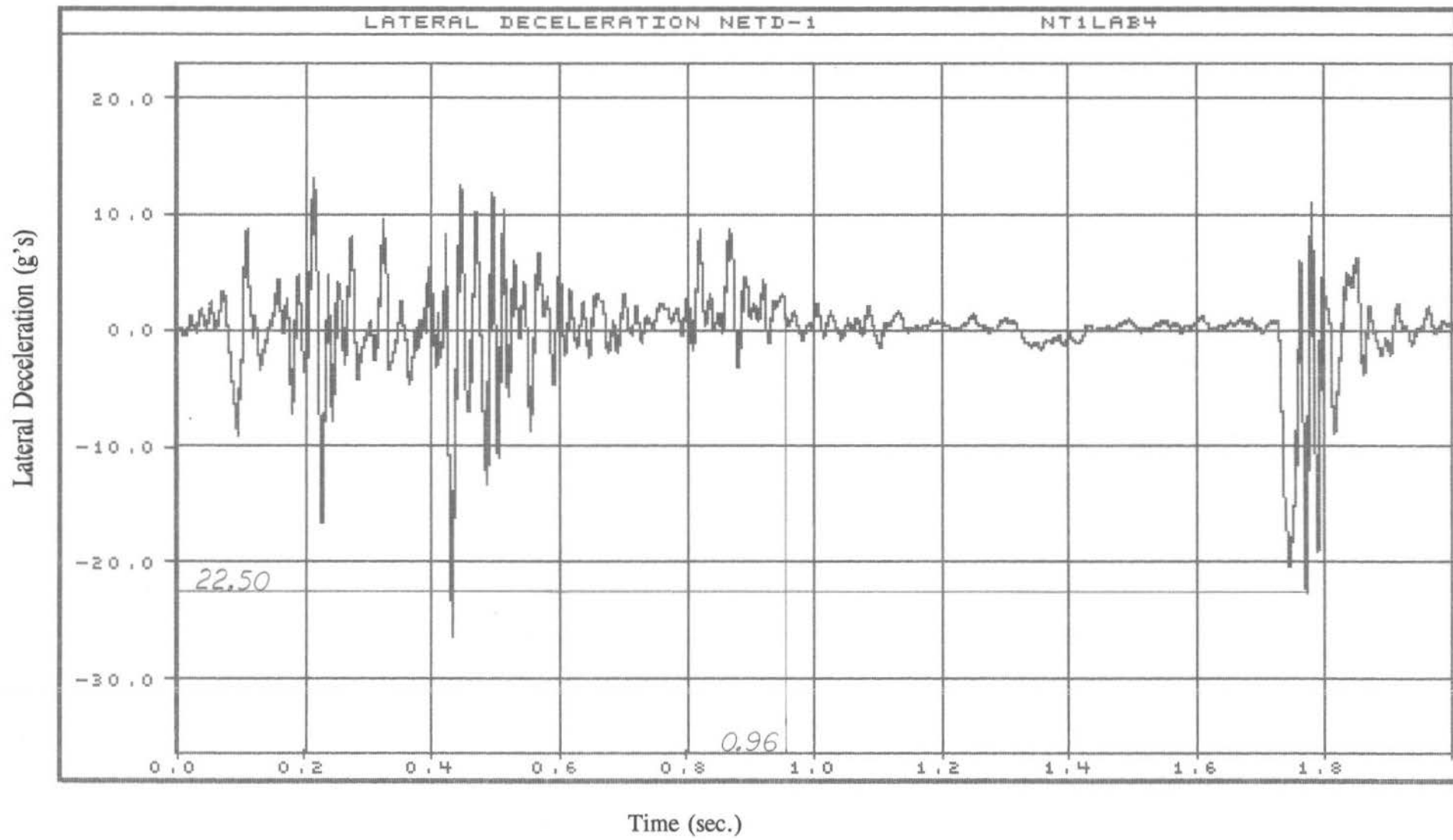

FIGURE A-5. GRAPH OF LATERAL DECELERATION, ACC. #4

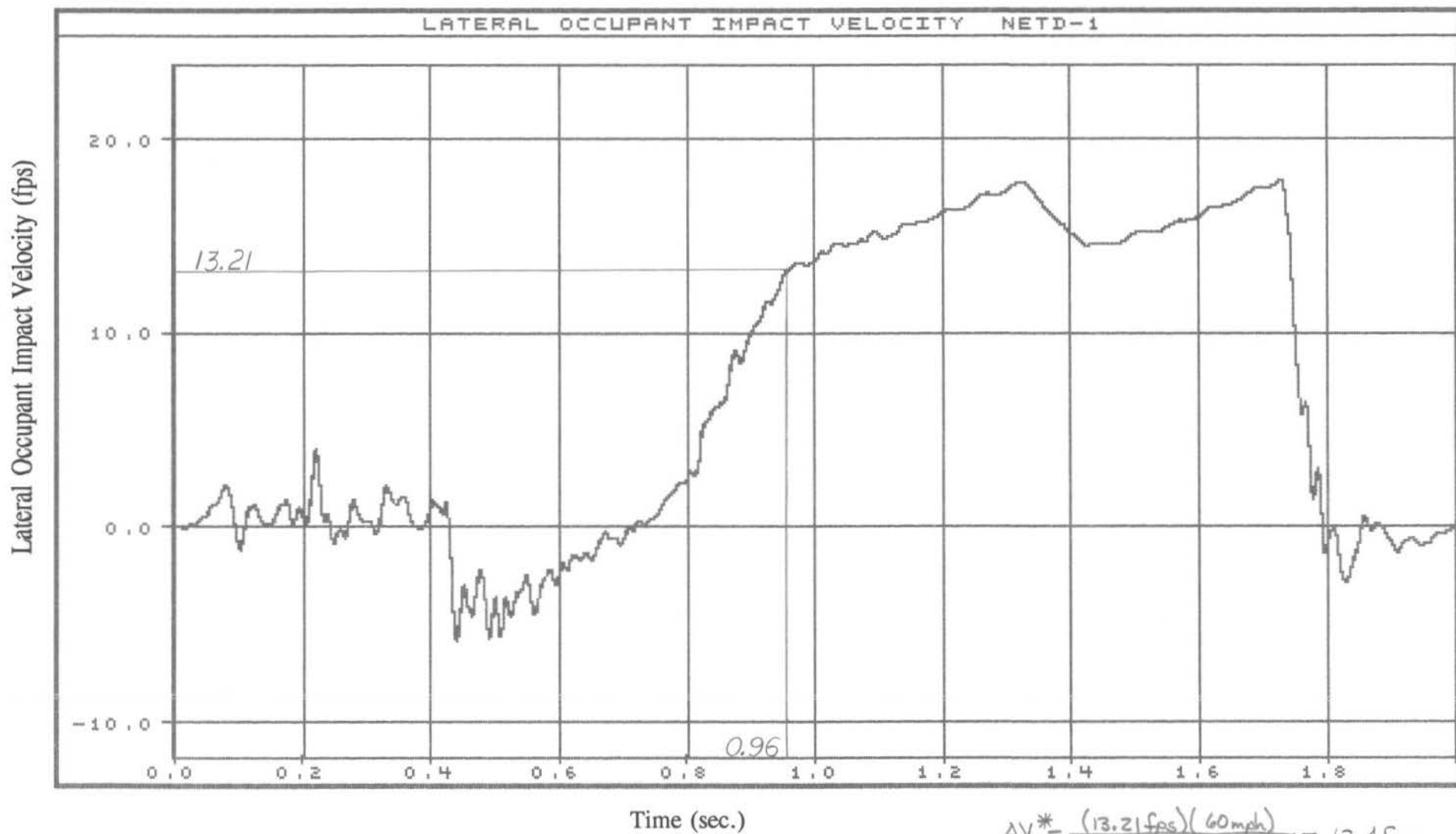

FIGURE A-6. GRAPH OF LATERAL OCCUPANT IMPACT VELOCITY, ACC. #4

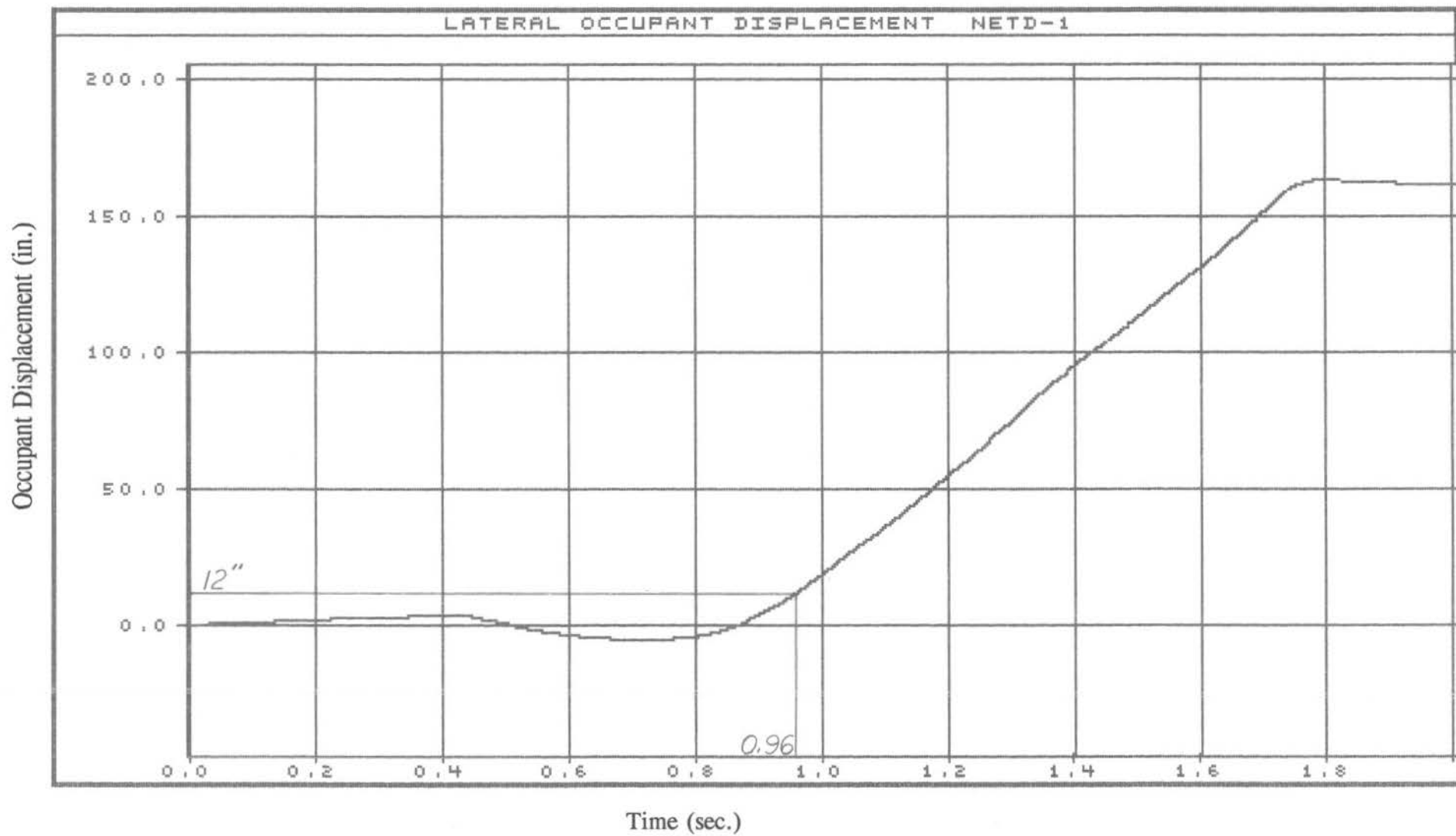

FIGURE A-7. GRAPH OF LATERAL OCCUPANT DISPLACEMENT, ACC. #4

**APPENDIX B.**  
**RELEVANT CORRESPONDENCE**



# STATE OF NEBRASKA

## DEPARTMENT OF ROADS

Allan L. Abbott, *Director-State Engineer*

1500 Nebraska Hwy 2

PO Box 94759

Lincoln NE 68509-4759

Phone (402) 471-4567

FAX (402) 479-4325



E. Benjamin Nelson  
*Governor*

May 5, 1992

Mr. Ron Faller  
Research Associate Engineer  
Midwest Roadside Safety Facility  
UNL - Civil Engineering Department  
P O Box 880531  
Lincoln NE 68588-0531

RE: RES1(0099) P464  
FY-92 Midwest States Pooled Fund Crash Tests

Dear Mr. Faller:

The Nebraska Department of Roads (NDOR) cancels the two remaining test on the Nebraska Approach Guardrail Terminal Section.

After failure of the first test at 60 mph, 0 deg. and 1.25' offset, NDOR personnel reviewed a proposed redesign. They felt it was not feasible to redesign the structure to fit the department's needs.

Sincerely,

Dalyce Ronnau  
Engineer of Research & Tests

cc: Mr. Ron Sietz, KSDOT  
Mr. Dan Davidson, MOHTD  
Mr. Bill Wendling, FHWA - Region 7  
Mr. Milo Cress, FHWA - Nebraska Division  
Mr. Don James, FHWA - Missouri Division  
Mr. Bob Alva, FHWA - Kansas Division