

10-2009

Termination and Anchorage of Temporary Concrete Barriers

Scott Rosenbaugh

University of Nebraska - Lincoln, srosenbaugh2@unl.edu

Robert W. Bielenberg

University of Nebraska - Lincoln, rbielenberg2@unl.edu

Ronald K. Faller

University of Nebraska - Lincoln, rfaller1@unl.edu

John R. Rohde

University of Nebraska - Lincoln, jrohde1@unl.edu

Dean L. Sicking

University of Nebraska - Lincoln, dsicking1@unl.edu

See next page for additional authors

Follow this and additional works at: <http://digitalcommons.unl.edu/ndor>



Part of the [Transportation Engineering Commons](#)

Rosenbaugh, Scott; Bielenberg, Robert W.; Faller, Ronald K.; Rohde, John R.; Sicking, Dean L.; Lechtenberg, Karla A.; Holloway, James C. M.S.C.E., E.I.T.; and Reid, John D., "Termination and Anchorage of Temporary Concrete Barriers" (2009). *Nebraska Department of Transportation Research Reports*. 74.
<http://digitalcommons.unl.edu/ndor/74>

This Article is brought to you for free and open access by the Nebraska LTAP at DigitalCommons@University of Nebraska - Lincoln. It has been accepted for inclusion in Nebraska Department of Transportation Research Reports by an authorized administrator of DigitalCommons@University of Nebraska - Lincoln.

Authors

Scott Rosenbaugh; Robert W. Bielenberg; Ronald K. Faller; John R. Rohde; Dean L. Sicking; Karla A. Lechtenberg; James C. Holloway M.S.C.E., E.I.T.; and John D. Reid

*Midwest States' Regional Pooled Fund Research Program
Fiscal Years 2005-2006 (Year 16)
Research Project Number SPR-3 (017)
NDOR Sponsoring Agency Code RFPF-06-02*

TERMINATION AND ANCHORAGE OF TEMPORARY CONCRETE BARRIERS

Submitted by

Scott K. Rosenbaugh, M.S.C.E., E.I.T.
Research Associate Engineer

Ronald K. Faller, Ph.D., P.E.
Research Assistant Professor

John R. Rohde, Ph.D., P.E.
Associate Professor

Karla A. Lechtenberg, M.S.M.E., E.I.T.
Research Associate Engineer

Robert W. Bielenberg, M.S.M.E., E.I.T.
Research Associate Engineer

John D. Reid, Ph.D.
Professor

Dean L. Sicking, Ph.D., P.E.
Professor and MwRSF Director

James C. Holloway, M.S.C.E., E.I.T.
Test Site Manager

MIDWEST ROADSIDE SAFETY FACILITY

University of Nebraska-Lincoln
527 Nebraska Hall
Lincoln, Nebraska 68588-0529
(402) 472-0965

Submitted to

MIDWEST STATES' REGIONAL POOLED FUND PROGRAM

Nebraska Department of Roads
1500 Nebraska Highway 2
Lincoln, Nebraska 68502

MwRSF Research Report No. TRP-03-209-09

October 29, 2009

TECHNICAL REPORT DOCUMENTATION PAGE

1. Report No. TRP-03-209-09	2.	3. Recipient's Accession No.	
4. Title and Subtitle TERMINATION AND ANCHORAGE OF TEMPORARY CONCRETE BARRIERS		5. Report Date October 29, 2009	
		6.	
7. Author(s) Rosenbaugh, S.K., Bielenberg, R.W., Faller, R.K., Reid, J.D., Rohde, J.R., Sicking, D.L., Lechtenberg, K.A., and Holloway, J.C.		8. Performing Organization Report No. TRP-03-209-09	
9. Performing Organization Name and Address Midwest Roadside Safety Facility (MwRSF) University of Nebraska-Lincoln 527 Nebraska Hall Lincoln, Nebraska 68588-0529		10. Project/Task/Work Unit No.	
		11. Contract © or Grant (G) No. SPR-3 (017)	
12. Sponsoring Organization Name and Address Midwest States' Regional Pooled Fund Program Nebraska Department of Roads 1500 Nebraska Highway 2 Lincoln, Nebraska 68502		13. Type of Report and Period Covered Final Report: 2005 – 2009	
		14. Sponsoring Agency Code RFPF-06-02	
15. Supplementary Notes Prepared in cooperation with U.S. Department of Transportation, Federal Highway Administration.			
16. Abstract (Limit: 200 words) <p>Free-standing temporary barrier designs have been used on our nation's highways for many years. Traditionally, these types of barriers have been designed and tested based solely on impacts in the middle of the barrier system or at the Length-Of-Need (LON). Historically, the assumption has been made that a crashworthy barrier system would perform adequately regardless of where it was impacted along the system length. However, it is believed that impacts closer to the system ends would very likely increase barrier deflections and may result in pocketing, vehicle climb, and/or vehicle instabilities, such as rollovers.</p> <p>This research study developed a termination anchorage for an F-shape temporary concrete barrier system that shortened the beginning of the LON for the system to the first barrier segment. The system was designed for use specifically with the Kansas F-shape temporary concrete barrier. The termination anchorage provided sufficient constraint to redirect vehicles impacting on the first barrier segment in the system, reduced vertical rotation of the end barrier segment to improve vehicle stability, used previously developed anchorage hardware, and could be attached to either end of the temporary barrier segment when placed on the upstream end of the system.</p> <p>The new termination and anchorage system for F-shape temporary concrete barriers was compliance tested according to the Test Level 3 safety requirements set forth in MASH. Full-scale crash test no. TTCB-1 was conducted according to the test no. 3-35 impact conditions as part of these requirements. Test no. TTCB-1 demonstrated a safe and successful redirection of the impacting vehicle, and the test was judged successful based on the MASH safety requirements. The test also showed that the termination anchorage successfully shortened the LON to the first barrier segment in the installation. Conclusions and recommendations regarding the implementation of the design are given in the report.</p>			
17. Document Analysis/Descriptors Roadside Safety, Temporary Concrete Barrier, F-shape Barrier, Temporary Barrier Termination, Temporary Barrier Anchorage, TL-3, Crash Testing, Compliance Testing		18. Availability Statement No restrictions. Document available from: National Technical Information Services, Springfield, Virginia 22161	
19. Security Class (this report) Unclassified	20. Security Class (this page) Unclassified	21. No. of Pages 153	22. Price

DISCLAIMER STATEMENT

This report was funded in part through grant(s) from the Federal Highway Administration (Federal Transit Administration), and U.S. Department of Transportation. The contents of this report reflect the views of the authors who are responsible for the facts and the accuracy of the data presented herein. The contents do not necessarily reflect the official views nor policies of the State Highway Departments participating in the Midwest States' Regional Pooled Fund Research Program, the Federal Highway Administration, or the U.S. Department of Transportation. This report does not constitute a standard, specification, or regulation.

UNCERTAINTY OF MEASUREMENT STATEMENT

The Midwest Roadside Safety Facility (MwRSF) has determined the uncertainty of measurements for several parameters involved in standard full-scale crash testing and non-standard testing of roadside safety hardware. Information regarding the uncertainty of measurements for critical parameters is available upon request by the sponsor and the Federal Highway Administration.

ACKNOWLEDGEMENTS

The authors wish to acknowledge several sources that made a contribution to this project:

(1) the Midwest States' Regional Pooled Fund Program funded by the California Department of Transportation, the Connecticut Department of Transportation, Illinois Department of Transportation, Iowa Department of Transportation, Kansas Department of Transportation, Minnesota Department of Transportation, Missouri Department of Transportation, Nebraska Department of Roads, New Jersey Department of Transportation, Ohio Department of Transportation, South Dakota Department of Transportation, Wisconsin Department of Transportation, and Wyoming Department of Transportation for sponsoring this project; and (2) MwRSF personnel for constructing the barriers and conducting the crash tests.

A special thanks is also given to the following individuals who made a contribution to the completion of this research project.

Midwest Roadside Safety Facility

C.L. Meyer, B.S.M.E., E.I.T., Research Associate Engineer
A.T. Russell, B.S.B.A., Shop Manager
K.L. Krenk, B.S.M.A, Maintenance Mechanic
A.T. McMaster, Laboratory Mechanic
Undergraduate and Graduate Research Assistants

California Department of Transportation

Gary Gauthier, Roadside Safety Research Specialist
Wes Lum, E.E., Office Chief National Liaison

Connecticut Department of Transportation

Dionysia Oliveira, Transportation Engineer 3

Illinois Department of Transportation

David Piper, P.E., Highway Policy Engineer

Iowa Department of Transportation

David Little, P.E., Assistant District Engineer
Deanna Maifield, P.E., Methods Engineer
Chris Poole, P.E., Litigation/Roadside Safety Engineer

Kansas Department of Transportation

Ron Seitz, P.E., Bureau Chief
Rod Lacy, P.E., Metro Engineer
Scott King, P.E., Road Design Leader

Minnesota Department of Transportation

Michael Elle, P.E., Design Standard Engineer

Missouri Department of Transportation

Joseph G. Jones, P.E., Engineering Policy Administrator

Nebraska Department of Roads

Amy Starr, P.E., Research Engineer
Phil TenHulzen, P.E., Design Standards Engineer
Jodi Gibson, Research Coordinator

New Jersey Department of Transportation

Richard Jaffee, Executive Manager, Civil Engineering Department

Ohio Department of Transportation

Dean Focke, P.E., Roadway Standards Engineer (retired)
Michael Bline, P.E., Standards and Geometrics Engineer

South Dakota Department of Transportation

David Huft, Research Engineer
Bernie Clocksin, Lead Project Engineer

Wisconsin Department of Transportation

John Bridwell, P.E., Standards Development Engineer
Erik Emerson, P.E., Standards Development Engineer

Wyoming Department of Transportation

William Wilson, P.E., Standards Engineer

Federal Highway Administration

John Perry, P.E., Nebraska Division Office
Danny Briggs, Nebraska Division Office

Dunlap Photography

James Dunlap, President and Owner

TABLE OF CONTENTS

TECHNICAL REPORT DOCUMENTATION PAGE i

DISCLAIMER STATEMENT ii

ACKNOWLEDGEMENTS iii

TABLE OF CONTENTS vi

LIST OF FIGURES viii

LIST OF TABLES xi

1 INTRODUCTION 1

 1.1 Background and Problem Statement 1

 1.2 Research Objectives 2

 1.3 Research Scope 2

2 LITERATURE REVIEW 4

 2.1 Previous Temporary Concrete Barrier Testing 4

 2.2 Current Practices For Temporary Barrier End Treatment 5

3 SYSTEM DESIGN AND ANALYSIS 7

 3.1 Design Requirements 7

 3.2 Design Loads 8

 3.3 Termination Anchor Concept 14

4 DESIGN DETAILS 19

5 TEST REQUIREMENTS AND EVALUATION CRITERIA 37

 5.1 Test Requirements 37

 5.2 Evaluation Criteria 39

6 TEST CONDITIONS 42

 6.1 Test Facility 42

 6.2 Vehicle Tow and Guidance System 42

 6.3 Test Vehicles 42

 6.4 Data Acquisition Systems 47

 6.4.1 Accelerometers 47

 6.4.2 Rate Transducers 47

 6.4.3 Pressure Tape Switches 48

 6.4.4 High Speed Photography 48

 6.4.5 String Potentiometers 49

7 FULL-SCALE CRASH TEST NO. TTCB-1 51
 7.1 Test No. TTCB-1 51
 7.2 Weather Conditions 51
 7.3 Test Description 51
 7.4 Barrier Damage 53
 7.5 Vehicle Damage 54
 7.6 Occupant Risk 55
 7.7 Discussion 56

8 SUMMARY AND CONCLUSIONS 77

9 RECOMENDATIONS 80

10 REFERENCES 100

11 APPENDICES 102
 APPENDIX A. Metric-Unit Design Details 103
 APPENDIX B. Vehicle Center of Gravity Determination 128
 APPENDIX C. Summary of Test Results in Metric Units 130
 APPENDIX D. Occupant Compartment Deformation Data 132
 APPENDIX E. Accelerometer and Rate Transducer Data Plots 136
 APPENDIX F. String Pot Data 150

LIST OF FIGURES

Figure 1. Case 1 – Pinned-End Constraint Loads	10
Figure 2. Case 1 – Pinned End Constraint Simulation.....	11
Figure 3. Case 2 – Spring Constraint Loads	12
Figure 4. Case 2 – Spring Constraint Simulation	13
Figure 5. Case 3 – 3-D Spring Constraint Simulation	15
Figure 6. Driven Steel Pile Anchorage	17
Figure 7. Force-Displacement Curve for Driven Steel Pile Anchorage	18
Figure 8. Test Installation Layout, Test No. TTCB-1.....	23
Figure 9. Anchorage Details, Test No. TTCB-1	24
Figure 10. Temporary Barrier Cable Connection Detail, Test No. TTCB-1	25
Figure 11. Temporary F-Shape Barrier and Pin Details, Test No. TTCB-1	26
Figure 12. Pin Sleeve Details, Test No. TTCB-1	27
Figure 13. Anchor Bracket Post Details, Test No. TTCB-1	28
Figure 14. Cable Anchor Bracket Details, Test No. TTCB-1.....	29
Figure 15. Anchor Bracket Components, Test No. TTCB-1	30
Figure 16. Cable Anchor Bracket Weld Details, Test No. TTCB-1	31
Figure 17. Cable Assembly Details, Test No. TTCB-1	32
Figure 18. Cable Securing Components, Test No. TTCB-1	33
Figure 19. Anchor Post Assembly Details, Test No. TTCB-1.....	34
Figure 20. Barrier System Test Installation, Test No. TTCB-1	35
Figure 21. Temporary Barrier Termination Anchorage, Test No. TTCB-1	36
Figure 22. Test Vehicle, Test No. TTCB-1	43
Figure 23. Vehicle Dimensions, Test No. TTCB-1	44
Figure 24. Target Geometry, Test No. TTCB-1	46
Figure 25. Camera Locations, Test No. TTCB-1.....	50
Figure 26. Summary of Test Results and Sequential Photographs, Test No. TTCB-1.....	57
Figure 27. Additional Sequential Photographs, Test No. TTCB-1	58
Figure 28. Additional Sequential Photographs, Test No. TTCB-1	59
Figure 29. Additional Sequential Photographs, Test No. TTCB-1	60
Figure 30. Documentary Photographs, Test No. TTCB-1	61
Figure 31. Impact Location, Test No. TTCB-1	62
Figure 32. Vehicle Final Position and Trajectory Marks, Test No. TTCB-1	63
Figure 33. System Damage, Test No. TTCB-1.....	64
Figure 34. System Damage - Barrier No. 1, Test No. TTCB-1	65
Figure 35. System Damage - Barrier No. 2, Test No. TTCB-1	66
Figure 36. System Damage - Back of Barrier No. 2, Test No. TTCB-1.....	67
Figure 37. System Damage - Barrier Nos. 3-5, Test No. TTCB-1	68
Figure 38. Anchorage Displacement, Test No. TTCB-1	69
Figure 39. Anchor Posts Displacement, No. Test No. TTCB-1	70
Figure 40. Vehicle Damage, Test No. TTCB-1	71
Figure 41. Damage to Right-Front of Vehicle, Test No. TTCB-1.....	72
Figure 42. Vehicle Right-Front Wheel Assembly Damage, Test No. TTCB-1.....	73
Figure 43. Damage to Right Side of Vehicle, Test No. TTCB-1.....	74

Figure 44. Vehicle Right-Rear Wheel Damage, Test No. TTCB-1 75
Figure 45. Vehicle Damage, Occupant Compartment, Test No. TTCB-1 76
Figure 46. Termination of Temporary Concrete Barrier, Final Design Details..... 81
Figure 47. Termination of Temporary Concrete Barrier, Final Design Details..... 82
Figure 48. Termination of Temporary Concrete Barrier, Final Design Details..... 83
Figure 49. Termination of Temporary Concrete Barrier, Final Design Details..... 84
Figure 50. Termination of Temporary Concrete Barrier, Final Design Details..... 85
Figure 51. Termination of Temporary Concrete Barrier, Final Design Details..... 86
Figure 52. Termination of Temporary Concrete Barrier, Final Design Details..... 87
Figure 53. Termination of Temporary Concrete Barrier, Final Design Details..... 88
Figure 54. Termination of Temporary Concrete Barrier, Final Design Details..... 89
Figure 55. Termination of Temporary Concrete Barrier, Final Design Details..... 90
Figure 56. Termination of Temporary Concrete Barrier, Final Design Details..... 91
Figure 57. Termination of Temporary Concrete Barrier, Final Design Details..... 92
Figure 58. Schematic of Sand Barrel Array for Termination and Anchorage System 95
Figure 59. Reverse Direction Impact Sand Barrel Array, 100 km/h (metric units)..... 97
Figure 60. Reverse Impact Sand Barrel Array, Various Speeds (metric units) 98
Figure A-1. Termination of Temporary Concrete Barrier, Test No. TTCB-1 104
Figure A-2. Termination of Temporary Concrete Barrier, Test No. TTCB-1 105
Figure A-3. Termination of Temporary Concrete Barrier, Test No. TTCB-1 106
Figure A-4. Termination of Temporary Concrete Barrier, Test No. TTCB-1 107
Figure A-5. Termination of Temporary Concrete Barrier, Test No. TTCB-1 108
Figure A-6. Termination of Temporary Concrete Barrier, Test No. TTCB-1 109
Figure A-7. Termination of Temporary Concrete Barrier, Test No. TTCB-1 110
Figure A-8. Termination of Temporary Concrete Barrier, Test No. TTCB-1 111
Figure A-9. Termination of Temporary Concrete Barrier, Test No. TTCB-1 112
Figure A-10. Termination of Temporary Concrete Barrier, Test No. TTCB-1 113
Figure A-11. Termination of Temporary Concrete Barrier, Test No. TTCB-1 114
Figure A-12. Termination of Temporary Concrete Barrier, Test No. TTCB-1 115
Figure A-13. Termination of Temporary Concrete Barrier, Final Design Details 116
Figure A-14. Termination of Temporary Concrete Barrier, Final Design Details 117
Figure A-15. Termination of Temporary Concrete Barrier, Final Design Details 118
Figure A-16. Termination of Temporary Concrete Barrier, Final Design Details 119
Figure A-17. Termination of Temporary Concrete Barrier, Final Design Details 120
Figure A-18. Termination of Temporary Concrete Barrier, Final Design Details 121
Figure A-19. Termination of Temporary Concrete Barrier, Final Design Details 122
Figure A-20. Termination of Temporary Concrete Barrier, Final Design Details 123
Figure A-21. Termination of Temporary Concrete Barrier, Final Design Details 124
Figure A-22. Termination of Temporary Concrete Barrier, Final Design Details 125
Figure A-23. Termination of Temporary Concrete Barrier, Final Design Details 126
Figure A-24. Termination of Temporary Concrete Barrier, Final Design Details 127
Figure B-1. Vehicle Mass Distribution, Test No. TTCB-1..... 129
Figure C-1. Summary of Test Results and Sequential Photographs (Metric), Test No. TTCB-1
..... 131
Figure D-1. Occupant Compartment Deformation Data – Set 1, Test No. TTCB-1 133

Figure. D-2. Occupant Compartment Deformation Data – Set 2, Test No. TTCB-1 134
Figure. D-3. Occupant Compartment Deformation Index (OCDI), Test No. TTCB-1 135
Figure E-1. Graph of 10 ms Average Longitudinal Deceleration (EDR-3), Test No. TTCB-1 . 137
Figure E-2. Graph of Longitudinal Occupant Impact Velocity (EDR-3), Test No. TTCB-1 138
Figure E-3. Graph of Longitudinal Occupant Displacement (EDR-3), Test No. TTCB-1 139
Figure E-4. Graph of 10 ms Average Lateral Deceleration (EDR-3), Test No. TTCB-1 140
Figure E-5. Graph of Lateral Occupant Impact Velocity (EDR-3), Test No. TTCB-1 141
Figure E-6. Graph of Lateral Occupant Displacement (EDR-3), Test No. TTCB-1 142
Figure E-7. Graph of 10 ms Average Longitudinal Deceleration (EDR-4), Test No. TTCB-1 . 143
Figure E-8. Graph of Longitudinal Occupant Impact Velocity (EDR-4), Test No. TTCB-1 144
Figure E-9. Graph of Longitudinal Occupant Displacement (EDR-4), Test No. TTCB-1 145
Figure E-10. Graph of 10 ms Average Lateral Deceleration (EDR-4), Test No. TTCB-1 146
Figure E-11. Graph of Lateral Occupant Impact Velocity (EDR-4), Test No. TTCB-1 147
Figure E-12. Graph of Lateral Occupant Displacement (EDR-4), Test No. TTCB-1 148
Figure E-13. Graph of Vehicle Roll, Pitch, and Yaw Angular Displacements, Test No. TTCB-1
..... 149
Figure F-1. String Potentiometer No. 1, Offset Anchor Data, Test No. TTCB-1 151
Figure F-2. String Potentiometer No. 6, Centerline Anchor Data, No. Test No. TTCB-1 152

LIST OF TABLES

Table 1. MASH Test Level 3 Crash Test Conditions 40
Table 2. MASH Evaluation Criteria for Crash Testing 41
Table 3. Camera and Lens Information, Test No. TTCB-1 48
Table 4. Weather Conditions, Test No. TTCB-1 51
Table 5. Summary of Safety Performance Evaluation Results, Test No. TTCB-1 79

1 INTRODUCTION

1.1 Background and Problem Statement

Temporary concrete barrier systems redirect errant vehicles through a combination of various forces and mechanisms, including inertial resistance developed by the acceleration of several barrier segments, lateral friction loads, and the tensile loads developed from the mass and friction of the barrier segments upstream and downstream of the impacted region. Dynamic testing of such barriers has normally occurred with the vehicle striking the system between 80 and 100 ft (24.4 and 30.5 m) downstream from the upstream end of a 200-ft (60.96-m) long barrier system. During one full-scale crash test, the ends of the temporary concrete barrier system moved as much as 2 in. (51 mm) [1]. Impacts closer to the system ends would very likely increase barrier deflections and may result in pocketing, vehicle climb, and/or vehicle instabilities, such as rollovers.

The impact behavior of temporary concrete barriers, when struck near the upstream end of the system, has never been investigated nor crash tested. Thus, no guidelines exist regarding the location of the beginning of length-of-need (LON) for a free-standing, temporary concrete barrier system. Currently, some roadway designers have assumed that the temporary barrier system was effective throughout the length of the system. However, previous full-scale crash testing has demonstrated that the beginning of LON for free-standing barriers may be a long distance away from the upstream end of the barrier. This fact has led other designers to extend a system another 80 to 100 ft (24.4 to 30.5 m) and flare the system away from the roadway. Unfortunately, errant vehicles impacting these additional barrier segments may result in vehicle rollover as well. Therefore, a method was needed for either shortening or eliminating the distance between the upstream end of the barrier system and the beginning of the LON.

The effects of placing additional barrier segments on the upstream end of the barrier system could be simulated with simple ground anchors that resist longitudinal motion. A strong ground anchor should be sufficient to allow temporary concrete barriers to achieve adequate capacity within the first one or two barrier segments. Such an anchorage system would place the beginning of LON at the first barrier segment and eliminate the need for extending the system farther upstream.

1.2 Research Objectives

The objectives of the research project were to design, test, and evaluate an economical method for terminating and anchoring the upstream end of temporary concrete barrier systems. This effort was to be performed in accordance with the Test Level 3 (TL-3) guidelines found in the Manual for Assessing Safety Hardware (MASH) [2]. The termination should provide adequate anchorage to allow for the beginning of the LON to be on or near the system's first barrier segment. The termination and anchorage system was developed for use with the Kansas F-shape temporary concrete barrier [3] that is currently used by several states participating in the Midwest Pooled Fund Program.

1.3 Research Scope

The research objectives were achieved by performing several tasks. First, a review of previous full-scale crash tests on temporary concrete barriers was performed in order to estimate the loads that would be applied to an anchorage system during vehicle impacts. Next, an anchorage system was developed using standard roadside safety hardware. Computer modeling and simulation was used to analyze, design, and modify the anchorage system to meet the specific needs of the temporary barrier system during high-energy, pickup truck impacts. Fourth, one full-scale vehicle crash test was performed using a 5,004-lb (2,270-kg) pickup truck at the

target conditions of 62 mph (100 km/h) and 25 degrees when impacting near the upstream end of the system. The results were then analyzed, evaluated, and documented. Finally, conclusions and recommendations were made that pertain to the safety performance of the new termination and anchorage system for use with the Kansas F-shape temporary concrete barrier system.

2 LITERATURE REVIEW

2.1 Previous Temporary Concrete Barrier Testing

Many full-scale crash tests have been performed on various temporary concrete barrier systems. However, temporary concrete barriers are normally tested with the vehicle striking the barrier almost 100 ft (30.5 m) downstream from the beginning of the system. In fact, no previous full-scale crash tests could be found in which a free-standing temporary concrete barrier system was impacted near the upstream end. Thus, the test descriptions in the following paragraphs are meant to demonstrate the barrier's effectiveness in length of need impact tests, not impacts at or near the ends. In addition, these crash tests refer to the F-shape, temporary concrete barrier segments, or at least slight design variations of that segment, that were used in this study.

In 1996, MwRSF conducted two full-scale crash tests on a free-standing temporary concrete median barrier system comprised of sixteen 12.5-ft (3.81-m) long, 32-in. (813-mm) tall F-shape barrier segments [4]. Both LON tests satisfied the Test Level 3 (TL-3) impact conditions set forth in NCHRP Report 350 [5] for longitudinal barriers. In test ITMP-1, the vehicle impacted the system 45.25-in. (1.15-m) upstream of the joint between barrier nos. 8 and 9 with a speed of 64.1 mph (103.1 km/h) and an angle of 27.6 degrees. During test no. ITMP-1, the truck climbed and overrode the barrier due to under-reinforced barrier ends and joints. The maximum permanent set deflection was 39.0 in. (0.99 m). For the second test, test no. ITMP-2, the barrier ends were given additional steel reinforcement. In test ITMP-2, the vehicle impacted the system 47.25-in. (1.2-m) upstream of the joint between barrier nos. 8 and 9 with a speed of 62.3 mph (100.3 km/h) and an angle of 27.1 degrees. During test no. ITMP-2, the barrier system safely contained and redirected the vehicle. The maximum permanent set and dynamic deflections were 44.875 in. (1.14 m) and 45.25 in. (1.15 m), respectively. As a result, the temporary concrete

barrier system was determined to be acceptable according to the evaluation criteria in NCHRP Report 350.

Early in the transition period of between NCHRP Report 350 and MASH, MwRSF conducted two full-scale crash tests on a free-standing temporary concrete median barrier system comprised of 12.5-ft (3.81-m) long, 32-in. (813-mm) tall, F-shape barrier segments [1,6]. Although these crash tests utilized two different full-size pickup trucks, a 2002 GMC 2500 ¾-ton and a 2002 Dodge Ram Quad Cab, both tests satisfied the vehicle specifications and impact conditions required in MASH. In test 2214TB-1, the vehicle impacted the system 48-in. (1.22-m) upstream of the joint between barrier nos. 8 and 9 with a speed of 61.9 mph (99.5 km/h) and an angle of 25.7 degrees. The maximum permanent set and dynamic deflections were 56.75 in. (1.44 m) and 56.75 in. (1.44 m), respectively. In test 2214TB-2, the vehicle impacted the system 48-in. (1.22-m) upstream of the joint between barrier nos. 8 and 9 with a speed of 61.9 mph (99.7 km/h) and an angle of 25.4 degrees. The maximum permanent set and dynamic deflections were 73 in. (1.85 m) and 79.65 in. (2.02 m), respectively. For both tests, the barrier system safely redirected the impacting vehicles. Thus, the temporary concrete barrier system was determined to be acceptable according to the evaluation criteria set in MASH.

2.2 Current Practices For Temporary Barrier End Treatment

Before undertaking the design of the upstream anchorage and termination system, MwRSF researchers wished to gain an understanding of the end treatments used by the members of the Midwest Pooled Fund Program. Two methods were commonly used. First, temporary concrete barrier systems are anchored to rigid barrier systems, if found adjacent to the ends of a temporary barrier system. It is important that a proper connection be made between a rigid barrier and a temporary barrier system in order to develop the tensile load necessary to redirect

an errant vehicle. In addition, connection of a free-standing temporary barrier to a rigid barrier requires the use of an approach transition to compensate for differences in the stiffness and deflection of the two adjacent systems [7-9].

The second common end treatment consisted of extending the barrier system past the LON. This method is used when it is not feasible to tie the system to a rigid structure. The added inertial effects and ground friction from the extra barrier segments provides a mechanism for the inter-barrier tensile loads to be carried throughout the impact region and beyond. Full-scale crash testing on temporary concrete barriers within the length of need, as described in the previous section, has shown that eight free-standing barrier segments upstream from the impact location are sufficient to redirect a vehicle under the MASH TL-3 conditions. Thus, it has become common practice to extend the barrier system an additional eight segments in order to protect a roadside hazard. This additional barrier length is often used to flare the system out of the critical zone for roadside applications or to overlap the front side of a bridge rail when it is not feasible to anchor the temporary concrete barrier directly to the bridge rail.

3 SYSTEM DESIGN AND ANALYSIS

3.1 Design Requirements

The development effort was first initiated with the identification of four main design criteria for use in configuring the termination and anchorage system. First, the termination system must develop sufficient loads to anchor the barrier system. The anchorage system should develop loads on the end barrier similar to those developed by adjacent barriers in the LON of the free-standing barrier system. It was also desired that the anchorage system develop these loads over some controlled displacement, such that the end barrier was not rigidly fixed. The controlled displacement of the anchor system would prevent the anchorage loads from becoming too high.

For the second design criterion, the termination system should mitigate vertical rotation and tipping of the end barrier about its longitudinal axis. Experience with safety shape barrier designs has shown that their sloped faces can allow vehicle climb and subsequent vehicle instabilities. Vertical rotation of the barrier segment about its longitudinal axis can further increase the potential for vehicle climb and instability. Thus, it was important to minimize the vertical rotation of the barrier.

The two remaining design criterion apply to the hardware used in the design. For the third criterion, the design needed to consider the use of existing hardware for the termination system in order to keep state DOT hardware inventories to a minimum and save costs. Fourth, the design must attach to either end of a barrier segment, since the temporary barrier design has different loop configurations on each end. With these criteria in mind, the researchers needed to determine the appropriate design loads for configuring the anchorage and termination system.

3.2 Design Loads

It was difficult to obtain the appropriate design loads for developing the termination and anchorage system through a review of previous crash testing studies or by simple analytical expressions. Tensile load data was unavailable from data taken in barrier joints and other associated hardware when subjected to full-scale crash testing in free-standing, temporary barrier installations. In addition, estimation of the barrier's tensile loads was unreliable due to the variation and spread in friction values. Thus, the researchers turned to finite element modeling using LS-DYNA [10].

In order to determine the loads for analyzing and designing the termination anchor system, LS-DYNA was used to investigate the behavior of terminating the temporary concrete barrier system under various end segment constraints. Information gathered from this modeling effort was used to design the actual end anchorage system, including its structural capacity and geometric layout. The temporary barrier model used was based on models previously developed and validated by MwRSF for temporary barrier applications in both free-standing and tied-down configurations [7,11]. The model consisted of twelve temporary barrier segments with various end segment constraints. The upstream barrier segment was impacted at 62.1 mph (100 km/h) and an angle of 25 degrees with the 2000P vehicle model. The impact point for the simulations was 4.3 ft (1,311 mm) upstream from the joint between the first two barrier segments. The 2000P vehicle model was used rather than a 2270P vehicle model because, to date, no 2270P vehicle model had been developed. It was recognized that the 2000P vehicle did not have as much mass nor kinetic energy as the 2270P vehicle planned for use in the compliance testing program. However, the researchers believed that the data from the 2000P vehicle simulations would prove

sufficient to give a general characterization of the magnitude of the loads imparted to the termination system.

Initially, the design loads were determined for a free-standing barrier system with the first upstream barrier constrained with a simple pinned-end condition at the end connection pin (i.e., rotation allowed about the vertical axis of the end pin only and no translation of the pin allowed). This “ideal” case was used to provide an understanding of the loads imparted to an anchor system where translation was not allowed as well as an indication of the vehicle and barrier performance. As expected, the 2000P vehicle was smoothly redirected by the barrier system, but at the cost of relatively high loads to the end constraint, as shown in Figure 1 and Figure 2. Longitudinal barrier loads were measured at approximately 140 kips (623 kN). As mentioned previously in the discussion of the design criteria, a rigid connection tends to create higher anchor loads. Thus, some deflection of the end anchor was desired to reduce these loads to manageable levels.

A second representation of the anchorage system was developed to replace the pinned-end condition using longitudinal and lateral springs. These springs allowed for controlled load and deflection of the simulated anchorage. The longitudinal spring was defined with an initial slope that rose to 30 kips (133.5 kN) over 5 in. (127 mm), then held constant at 30 kips (133.5 kN) for another 5 in. (127 mm), and finally released or failed after 10 in. (254 mm) of total deflection. The lateral spring constraint was defined similar to the longitudinal spring, but with one tenth of the longitudinal strength. Results from this simulation found that the loads on the upstream end barrier were significantly reduced with the deformable end condition. However, the displacements of the upstream end of the barrier system were considered excessive and led to concerns for barrier pocketing and vehicle stability, as shown in Figure 3 and Figure 4.

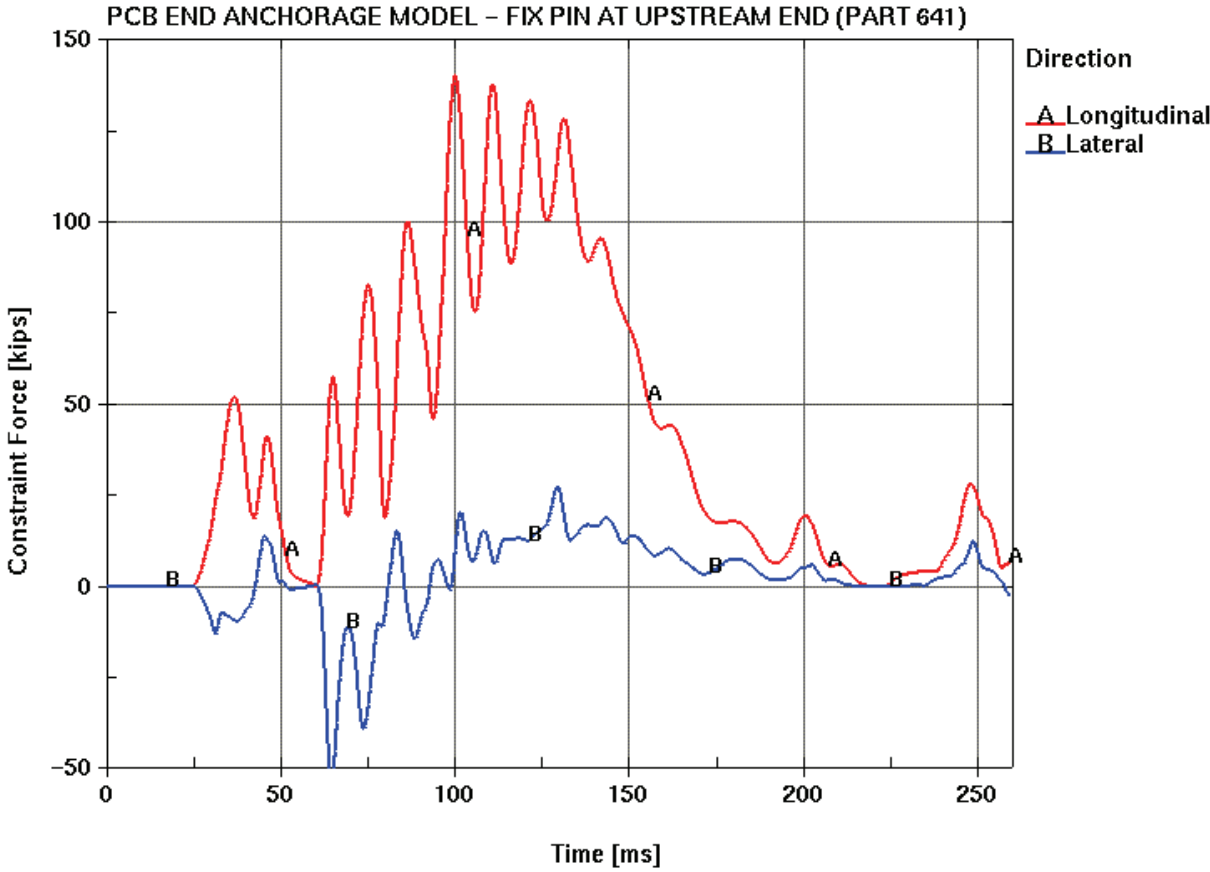

Figure 1. Case 1 – Pinned-End Constraint Loads

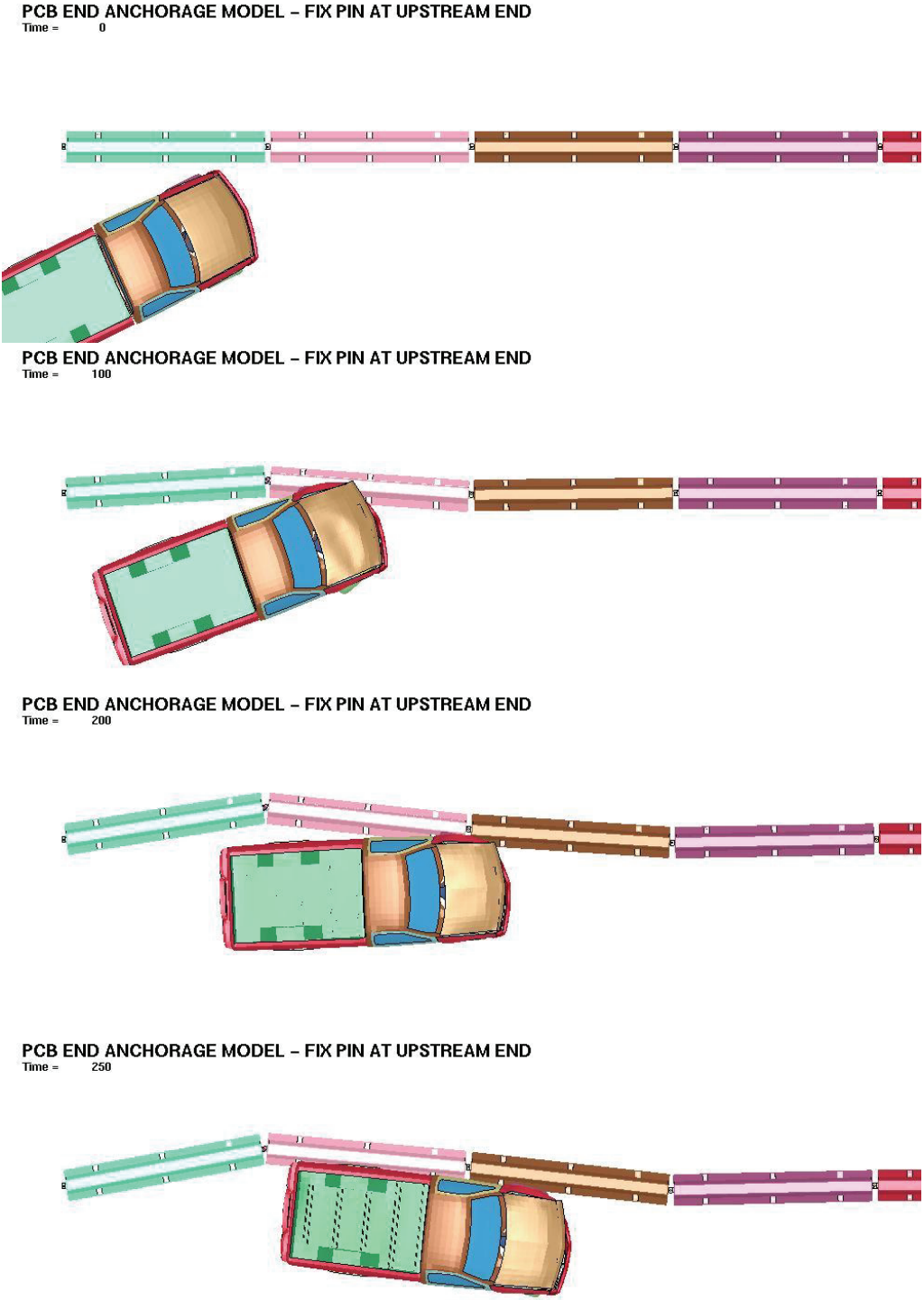

Figure 2. Case 1 – Pinned End Constraint Simulation

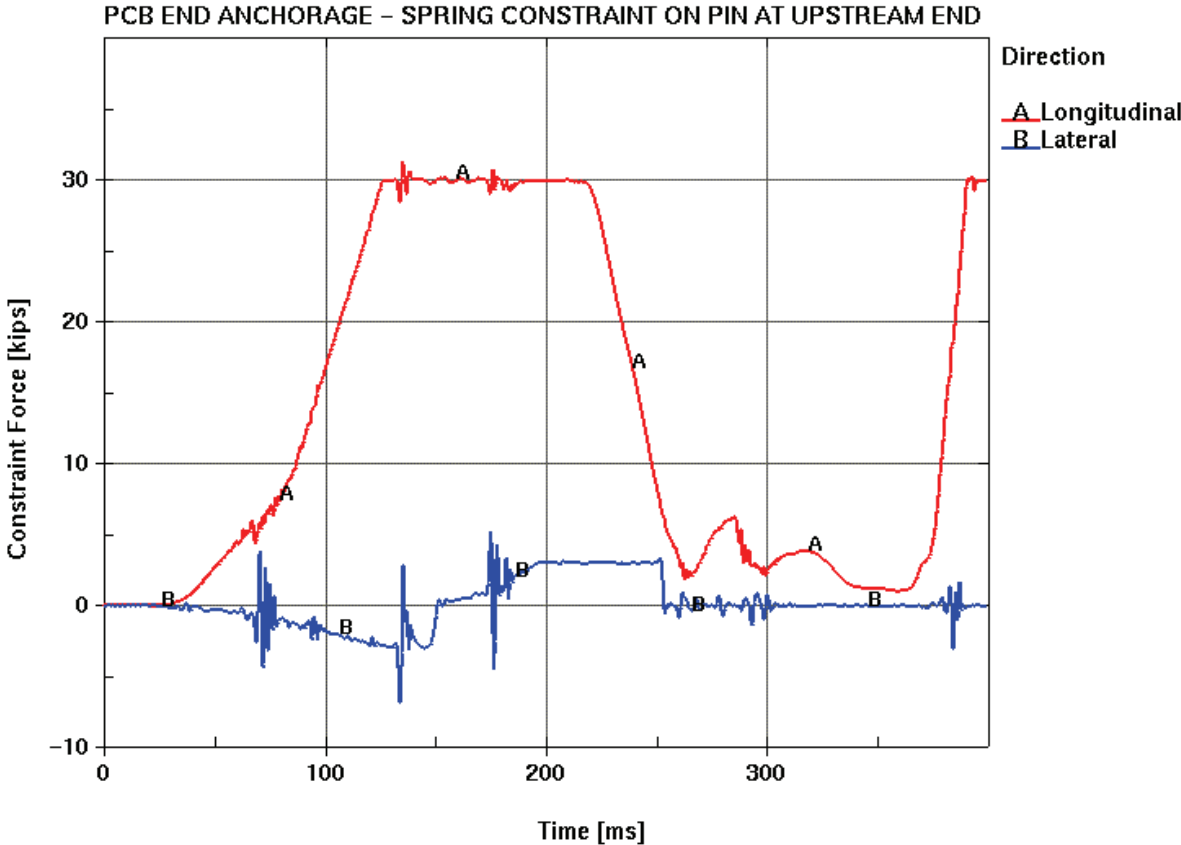

Figure 3. Case 2 – Spring Constraint Loads

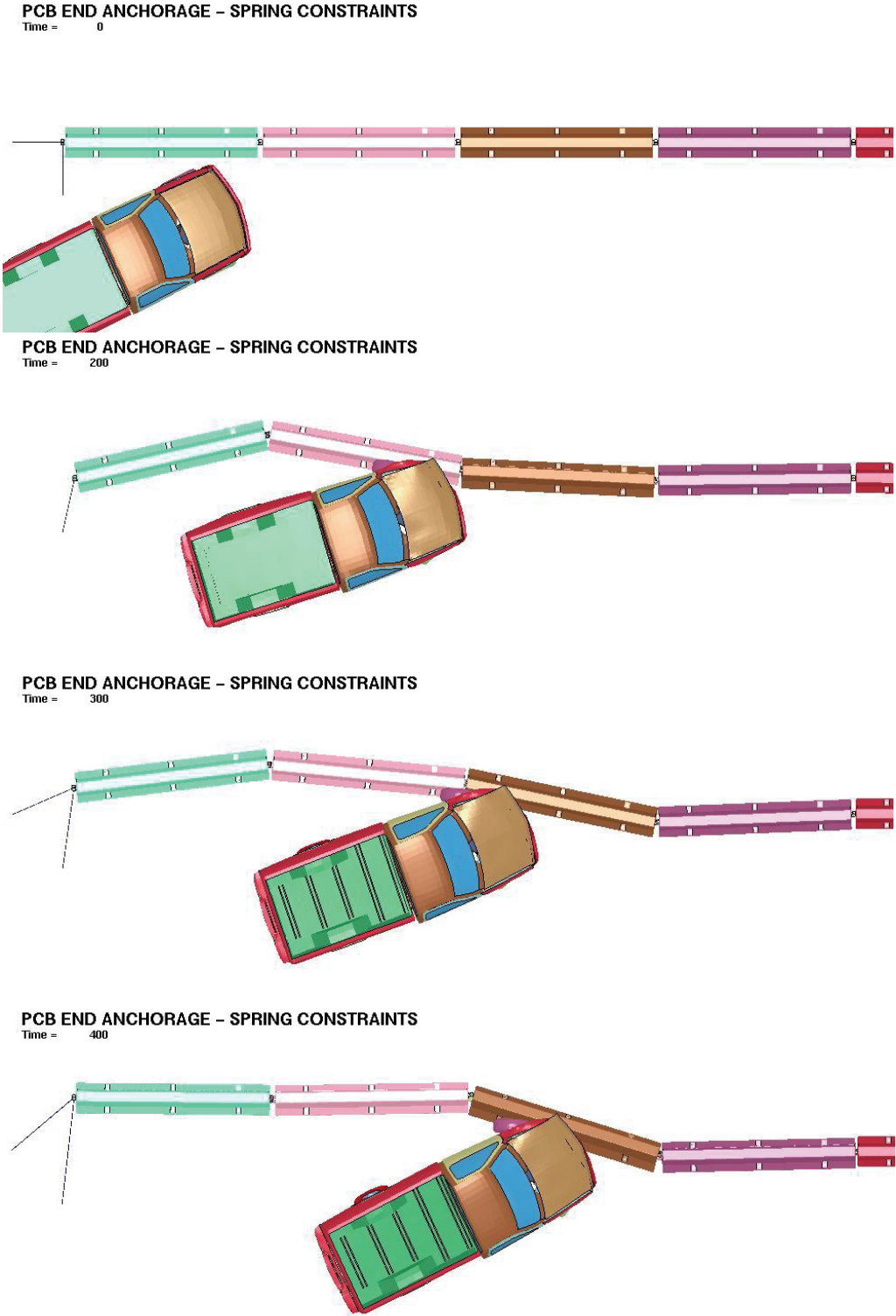

Figure 4. Case 2 – Spring Constraint Simulation

The third simulated end condition switched the end constraint to a 3-D spring with one end fixed upstream of the barrier at the ground line and the other end attached to the barrier half-way between the end loop bars. The redefined end constraint better represented the type of ground to barrier connection that would be used in the final design and added a vertical constraint to barrier rotation not previously applied. In addition, the 3-D spring was defined with higher capacity than the previous spring in order to reduce barrier deflections. The new spring was defined with an initial slope that rose to 80 kips (356 kN) over 10 in. (254 mm), then held constant at 80 kips (356 kN) for another 10 in. (254 mm), and finally released or failed after 20 in. (508 mm) of total deflection. The spring was placed vertically half-way between loops at the mid-height of the barrier. This end condition helped to improve the barrier deflections and did not demonstrate barrier motions that would cause concern for vehicle stability, as shown in Figure 5.

Based on the results of this analysis and the design criteria discussed in the previous section, the researchers decided that the termination and anchorage system should be designed to develop 80 kips (356 kN) of load over approximately 10 in. (254 mm) of deflection. In addition, it was desired that the termination and anchorage system should provide some measure of both vertical and lateral restraint in order to control barrier deflections and rotations that could lead to vehicle instability.

3.3 Termination Anchor Concept

Several potential ideas were considered for the termination anchor that attempted to meet the desired design criteria and design loads. The optimum design solution for the anchorage system was to adopt a driven steel pile, similar to that used in previous cable guardrail projects. During the development of a low-tension, cable guardrail system for use near fill slopes, MwRSF

PCB END ANCHORAGE – SPRING CONSTRAINT O

Time = 0

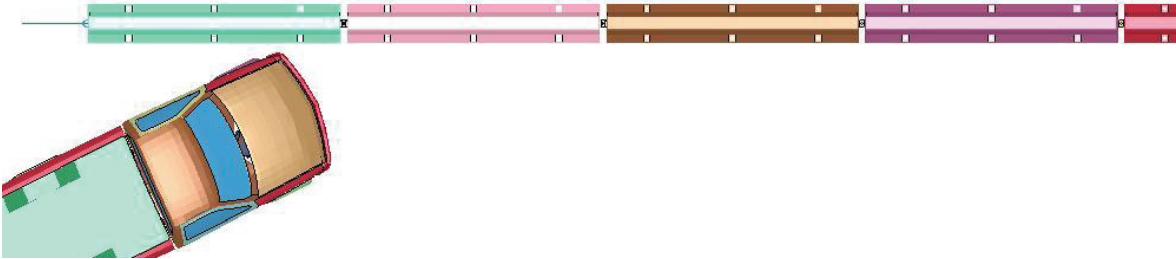

PCB END ANCHORAGE – SPRING CONSTRAINT O

Time = 200

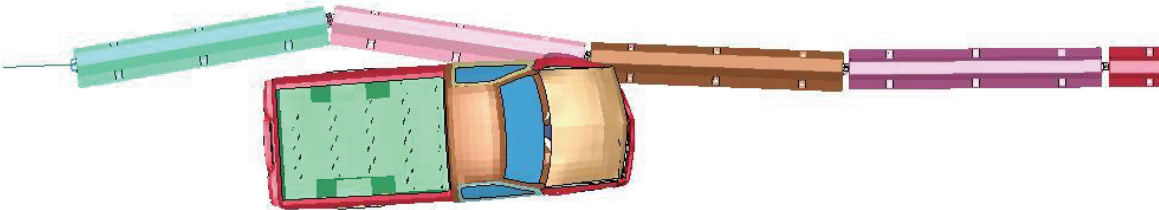

PCB END ANCHORAGE – SPRING CONSTRAINT O

Time = 300

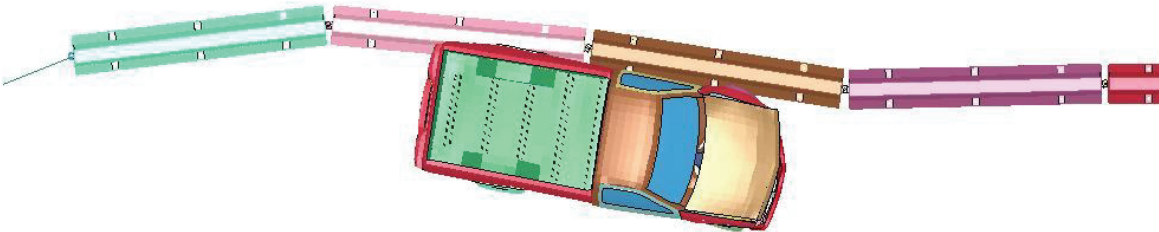

PCB END ANCHORAGE – SPRING CONSTRAINT O

Time = 400



Figure 5. Case 3 – 3-D Spring Constraint Simulation

researchers tested several end anchorage designs [12]. One of these anchorage systems incorporated a driven steel pile, as shown in Figure 6. During that study, the steel pile anchorage was tested in a dynamic component test and was found to develop 40 kips (178 kN) of load over a deflection of 10 in. (254 mm), as shown in Figure 7. The researchers believed that the use of two of these steel pile anchors would meet the 80 kip (356 kN) design load requirement as well as meet the design criteria recommending the use of existing hardware. One steel pile would be mounted upstream and in line with the centerline of the upstream barrier end. This first pile would attach near the bottom of the barrier and provide primarily a tensile constraint for the end barrier. The second steel pile would be installed with a slight lateral offset toward the traffic-side face of the barrier and would attach to the upstream barrier end near the top loop bar. This pile would provide additional tensile constraint as well as provide some lateral constraint and resistance to barrier rotations about the longitudinal axis.

The steel piles were offset from the barrier to allow for anchor displacement in the soil while developing the necessary anchor capacity. As such, a method was needed to connect the steel piles to the upstream end of the barrier. The most efficient connection method utilized cable assemblies similar to those used for anchoring W-beam guardrail systems. These cable assemblies allowed for tightening the end anchorage as well as provided some tolerance for the placement of the piles. One end of the cable assembly was designed with a threaded end that connected to a mounting bracket on top of the steel pile. The other end had a simple cable loop that would attach to a steel connection pin passing through the loops on the end of the barrier. Full details on this connection are presented in Chapter 4.

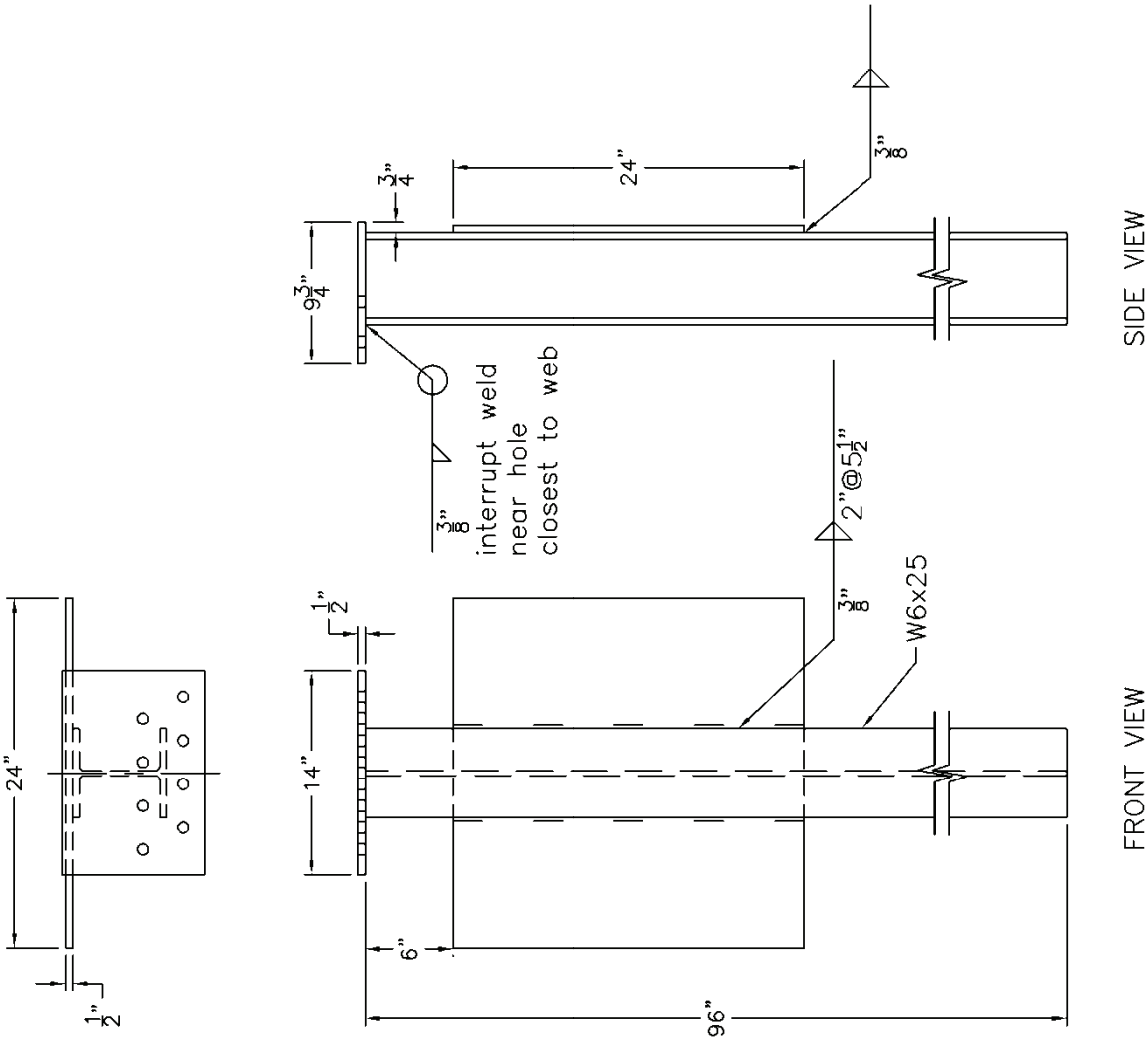

Figure 6. Driven Steel Pile Anchorage

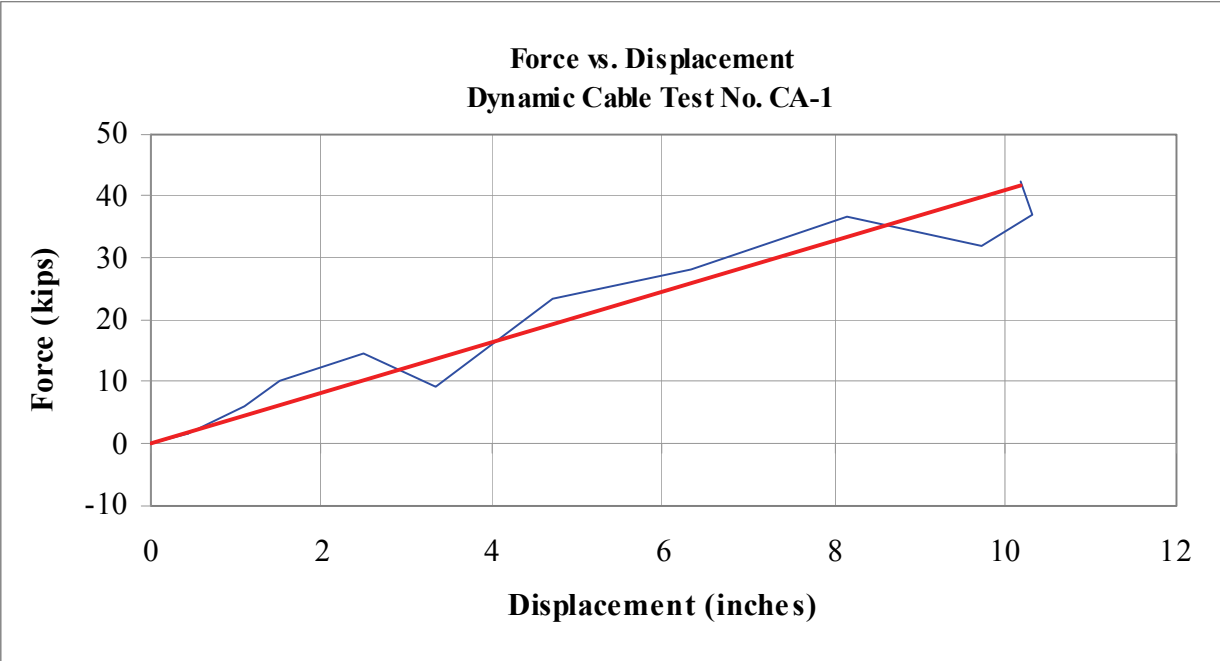

Figure 7. Force-Displacement Curve for Driven Steel Pile Anchorage

4 DESIGN DETAILS

The 156.5-ft (47.7-m) long test installation, as shown in Figure 8, consisted of two major components: (1) twelve segments of 32-in. (813-mm) tall F-shape, temporary concrete barrier installed on a concrete surface and (2) an anchorage system composed of two $\frac{3}{4}$ -in. (19-mm) diameter wire cables and two anchor post assemblies. Design details are shown in Figure 8 through Figure 19. The corresponding metric-unit drawings are shown in Appendix A. Photographs of the test installation are shown in Figures 20 and 21.

The concrete barrier utilized Iowa's Concrete Barrier Mix, which was configured with a minimum 28-day concrete compressive strength of 5,000 psi (34.5 MPa). A minimum concrete cover varied at different rebar positions within the barrier. A minimum concrete cover of 2 in. (51 mm) was used along the top of the vertical stirrup rebar and at the bottom of the longitudinal rebar. Minimum concrete cover of 1 $\frac{3}{4}$ in. (44 mm) and 1 in. (25 mm) were used along the sides of the vertical stirrup rebar and at the rebar around the anchor bolt block, respectively. All steel reinforcement in the barrier conformed to ASTM A615 Grade 60 rebar, except for the loop bars which were ASTM A706 Grade 60 rebar. The barrier reinforcement details are shown in Figure 11.

Barrier reinforcement consisted of three No. 5 and two No. 4 longitudinal bars, twelve No. 4 bars for the vertical stirrups, and six No. 6 bars for the anchor bolt block reinforcement loops. Each of the five longitudinal rebar was 12 ft 2 in. (3.71 m) long. The vertical spacing of the lower, middle, and upper longitudinal bars were 6.5 in. (165 mm), 14.5 in. (368 mm), and 29 $\frac{1}{8}$ in. (780 mm) from the ground to their centers, respectively. The vertical stirrups were 72-in. (1,829-mm) long and were bent into the shape of the barrier. Their spacing varied longitudinally, as shown in Figure 11. The reinforcing steel loops used around the tie-down anchor holes in the

barrier were 35 in. (889 mm) long, were bent into a U-shape, and were used to reinforce the anchor bolt area.

The barriers used a pin and loop type connection comprised of two sets of three rebar loops on each barrier interconnection. Each loop assembly was configured with three ASTM A706 Grade 60 No. 6 bars that were bent into a loop shape. The vertical pin used in the connection consisted of a 1 ¼ in. (32-mm) diameter x 28-in. (711-mm) long round bar comprised of ASTM A36 steel. The pin was held in place using one 2 ½-in. wide x 4-in. long x ½-in. thick (64-mm x 102-mm x 13-mm) ASTM A36 steel plate with a 1 3/8-in. (35-mm) diameter hole centered on it. The plate was welded 2 ½ in. (64 mm) below the top of the pin. A gap of 3 5/8 in. (92 mm) between the ends of two consecutive barriers was formed from the result of pulling the connection taut.

The upstream-most barrier segment was installed with 36 in. of the downstream end placed on the concrete surface and the remainder of the barrier segment resting on soil. This end barrier was anchored by two cable assemblies that connected the end connector pin to two driven, steel pile, anchor posts. Each of the two anchor posts was a 8-ft (2,438-mm) long, W6x25 (W152x37.2) steel section with a 24-in. x 24-in. x ½-in. thick (610-mm x 610-mm x 13-mm) soil plate welded to the front flange and a ½-in. (13-mm) thick plate welded to the top of the post, as shown in Figure 19. The anchor posts were placed in soil with an embedment depth of 8 ft (2,438 mm). One post was located along the longitudinal axis of the system, 45 3/8 in. (1,153 mm) upstream the edge of the first barrier. The second post was located 29 3/8 in. (746 mm) upstream of the first barrier and offset 11 ½ in. (292 mm) laterally from the traffic side face of the barrier. The soil pit underneath the asphalt surface was comprised of a crushed limestone aggregate soil satisfying the standard soil requirements of MASH. Cable brackets were bolted to the top of the

anchor posts, as shown in Figures 8, 9, and 13. The cable brackets were assembled from multiple ½-in. (13-mm) thick, A36 steel plates welded together, as shown in Figures 14 through 16.

The cable assemblies were comprised of a ¾-in. (19-mm) diameter, 7x19 wire rope, BCT cable end fitting, a Crosby heavy-duty HT thimble, and a 115-HT mechanical splice, as shown in Figures 17 and 18. It should be noted that the wire ropes were ordered as 6x19 IWRC IPS wire ropes in order to be consistent with the wire rope specifications for W-beam guardrail cable anchorages. However, the manufacturer substituted the 7x19 wire rope as an equivalent to the 6x19 IWRC IPS. The substitution was not determined until the wire ropes were disassembled after the full-scale crash test. One 54 ¾ in. (1,391 mm) long cable assembly was aligned with the longitudinal axis of the barrier system. This cable assembly was attached with one end fixed between the lower barrier loops on an additional connection pin on the upstream end of the barrier and the other end attached to the anchor post. The end connector pin utilized a second 2 ½-in. wide x 4-in. long x ½-in. thick (64-mm x 102-mm x 13-mm) ASTM A36 steel plate and a ½-in. diameter x 10-in. long (13-mm diameter x 254-mm long) Grade 8 hex bolt and nut at the bottom of the pin to prevent the pin from pulling out of the barrier loops when the anchorage was loaded. The second cable assembly measured 48 3/8 in. (1,229 mm) long, and it was attached from just below the top barrier loop on the connector pin on the end of the barrier to the offset anchor post, as shown in Figures 8 through 10 and 21. A pin sleeve, made from 1 ½ in. (38 mm) Schedule 40 pipe, was used to keep the anchor cables in the correct vertical positions. The use of the pin sleeve also allowed the cable anchorages to be attached at the same vertical position on the end pin regardless of which end of the F-shape barrier was used. Thus, if the barrier ends were reversed, the offset cable would attach to the connection pin between the top two barrier

loops, and the in-line cable would attach to the connection pin between the pin sleeve and lower barrier loop.

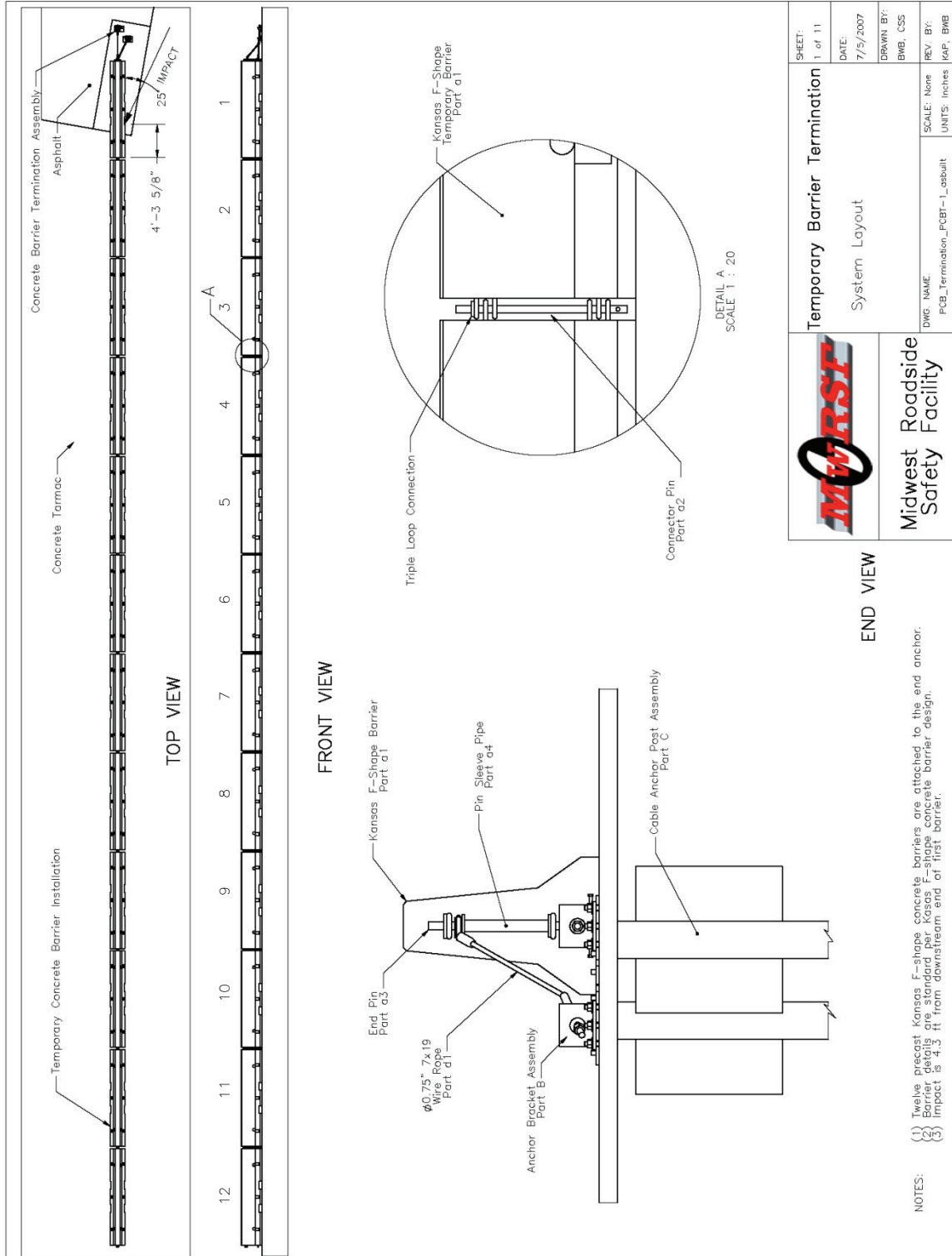
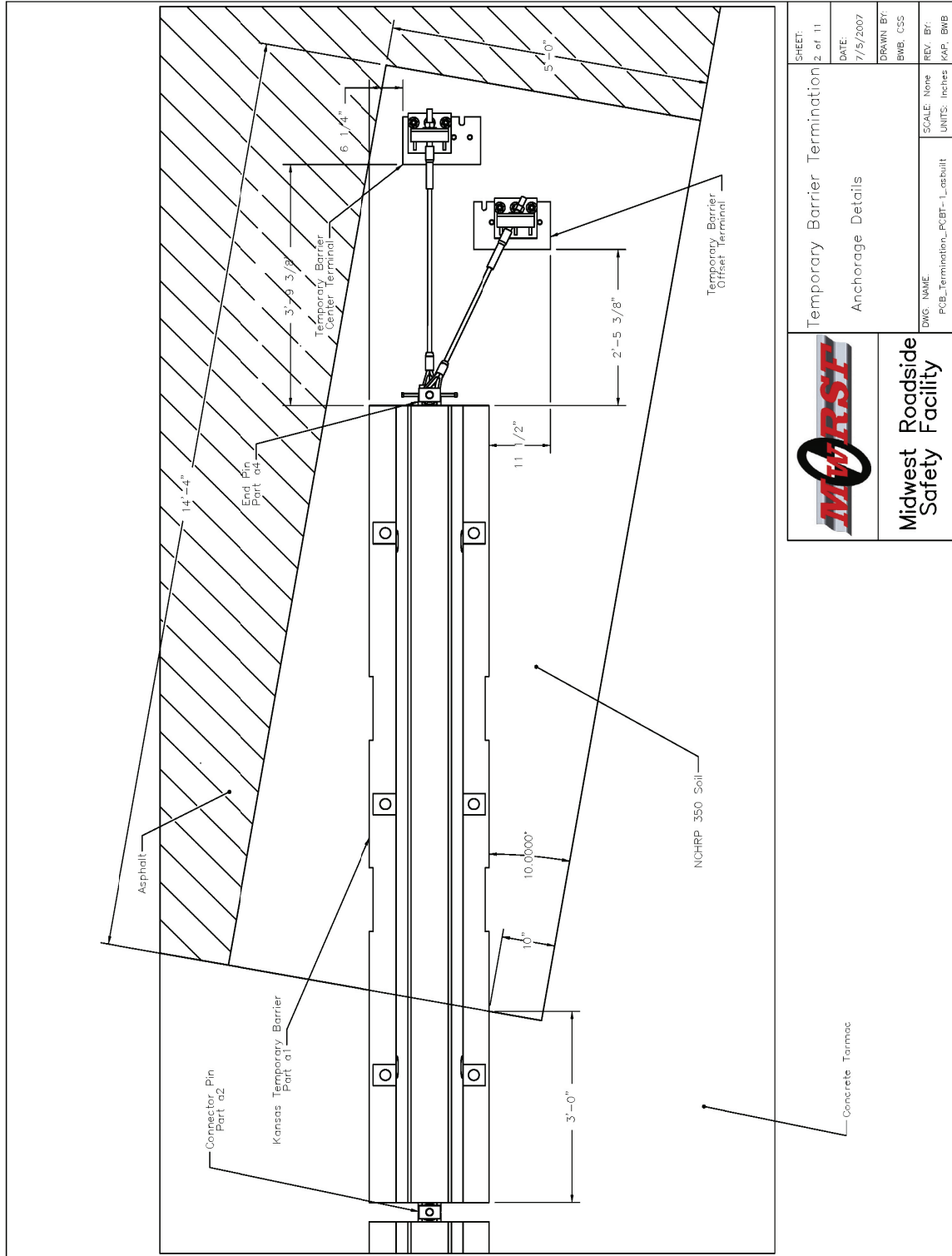

Figure 8. Test Installation Layout, Test No. TTCB-1



		Midwest Roadside Safety Facility	
Temporary Barrier Termination Anchorage Details		DWG. NAME: PCB_Termination_PCB-1_asbuilt	SCALE: None UNITS: inches
SHEET: 2 of 11	DATE: 7/5/2007	DRAWN BY: BMB, CSS	REV. BY: KAP, BMB

Figure 9. Anchorage Details, Test No. TTCB-1

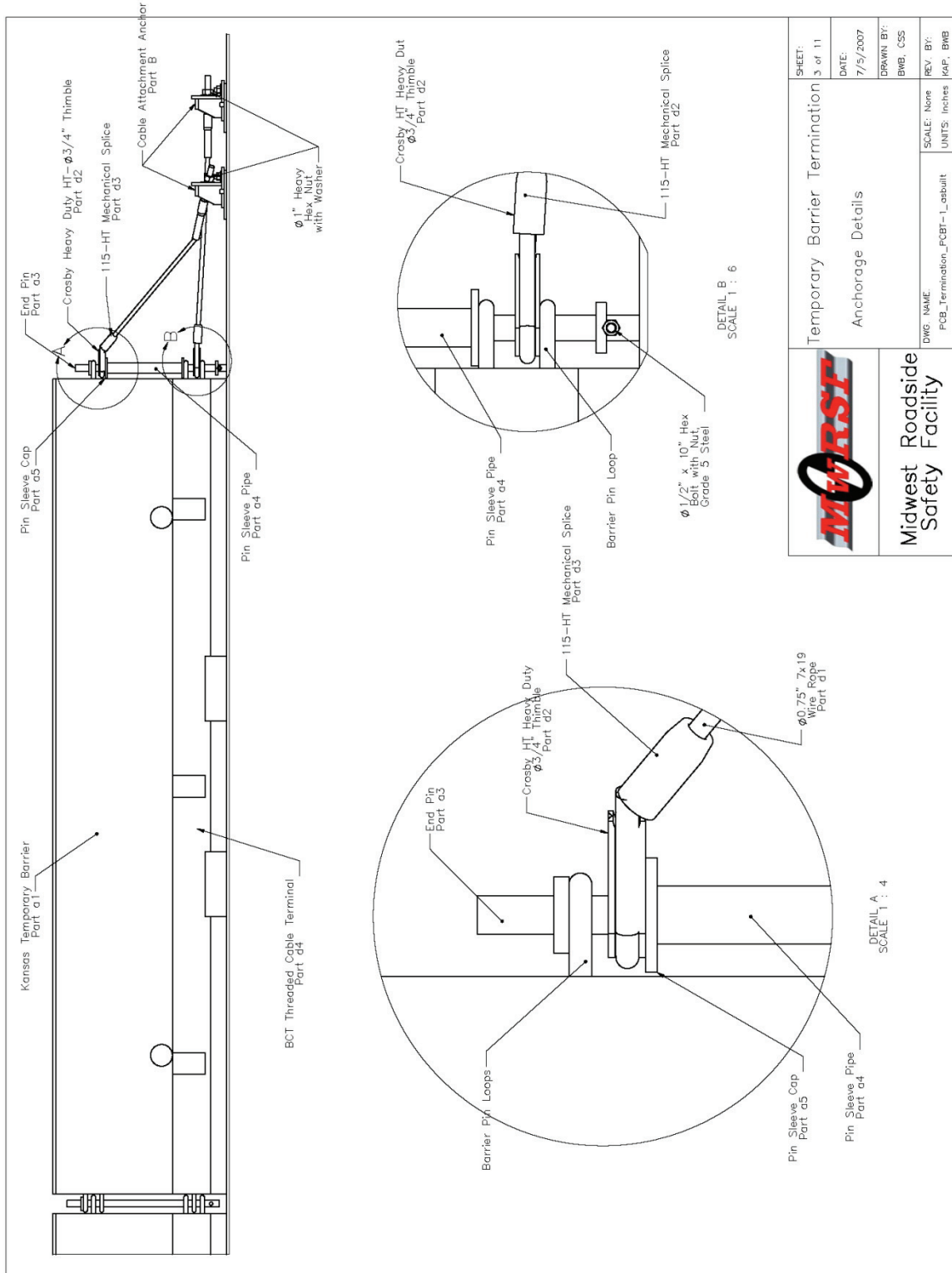

Figure 10. Temporary Barrier Cable Connection Detail, Test No. TTCB-1

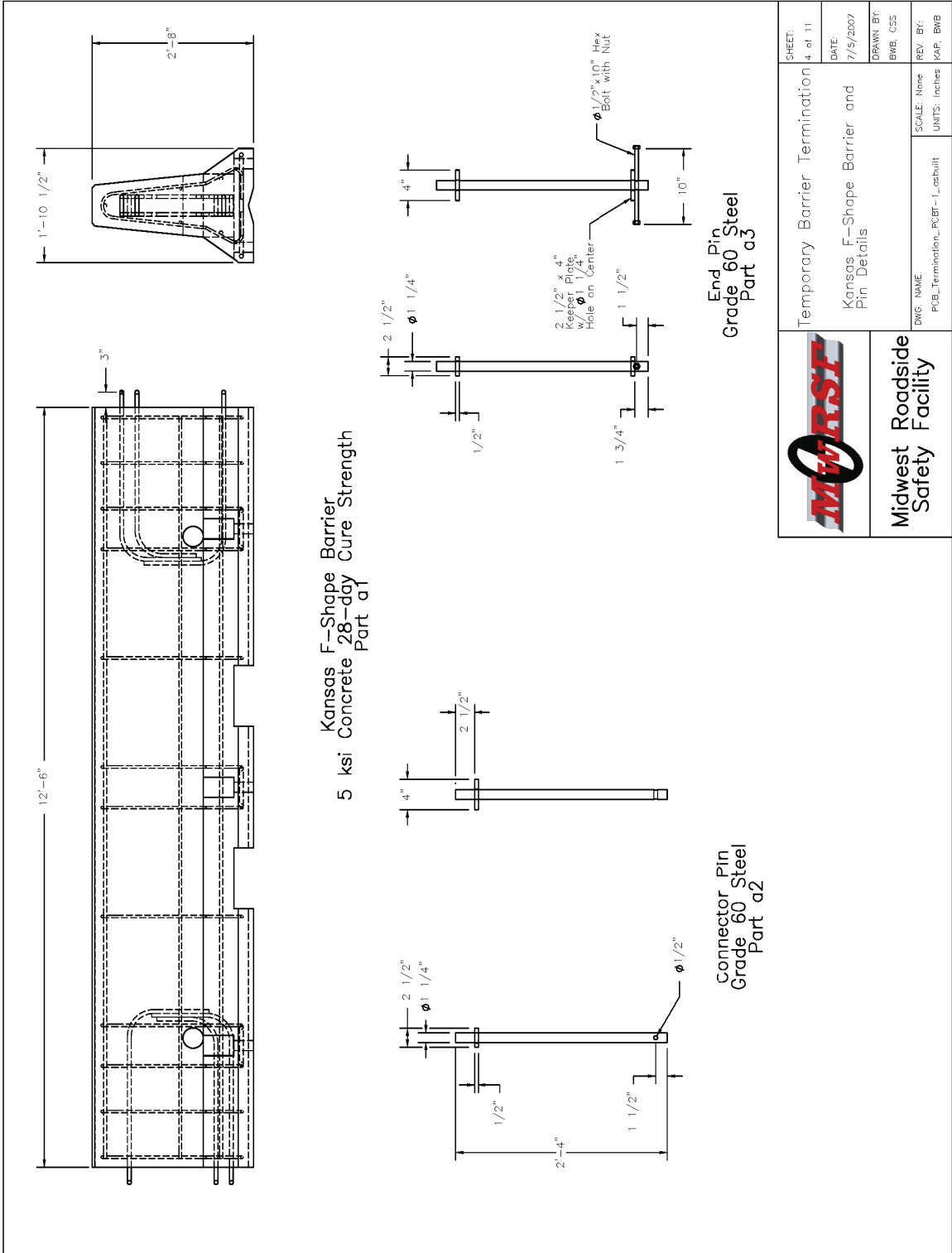

Figure 11. Temporary F-Shape Barrier and Pin Details, Test No. TTCB-1

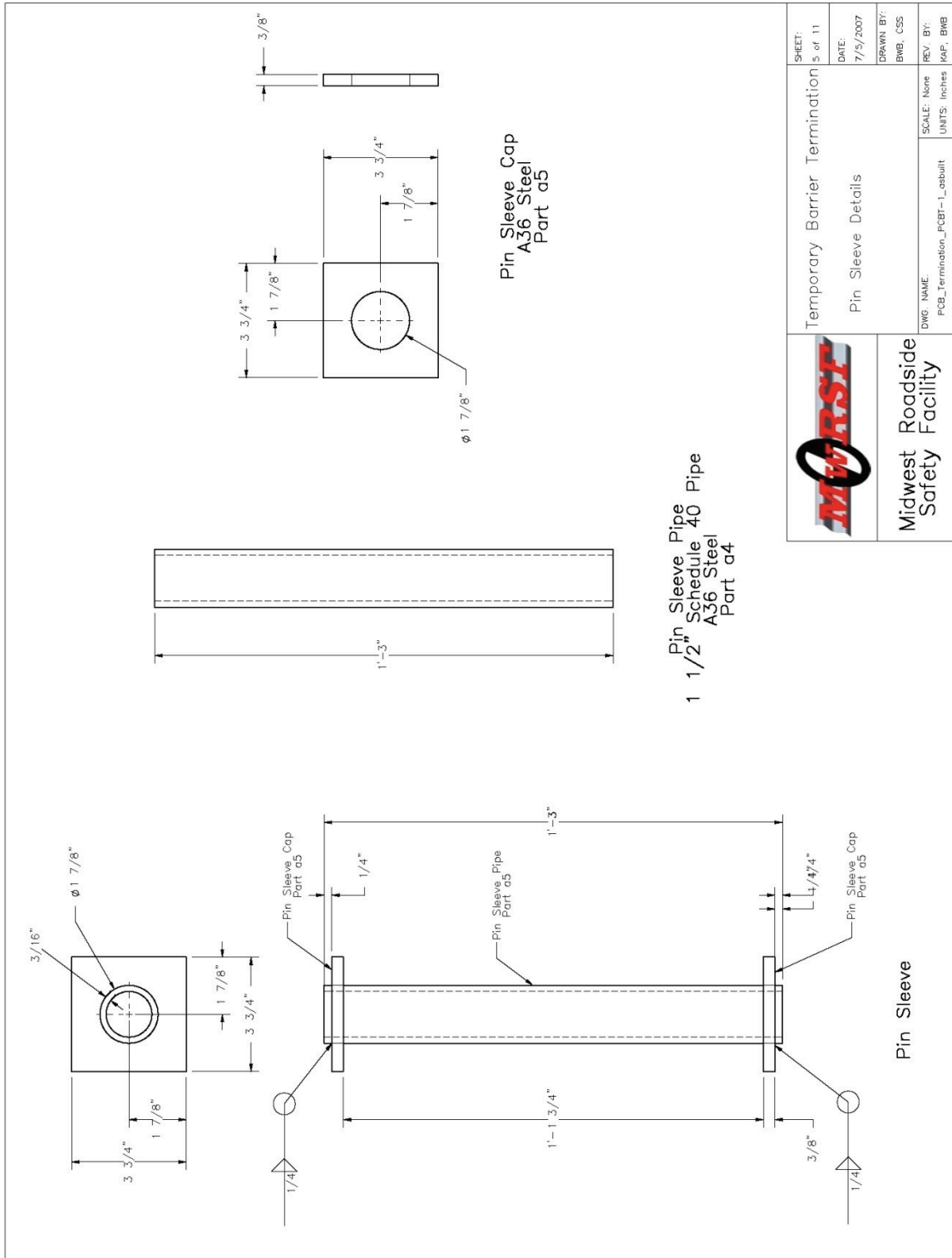

Figure 12. Pin Sleeve Details, Test No. TTCB-1

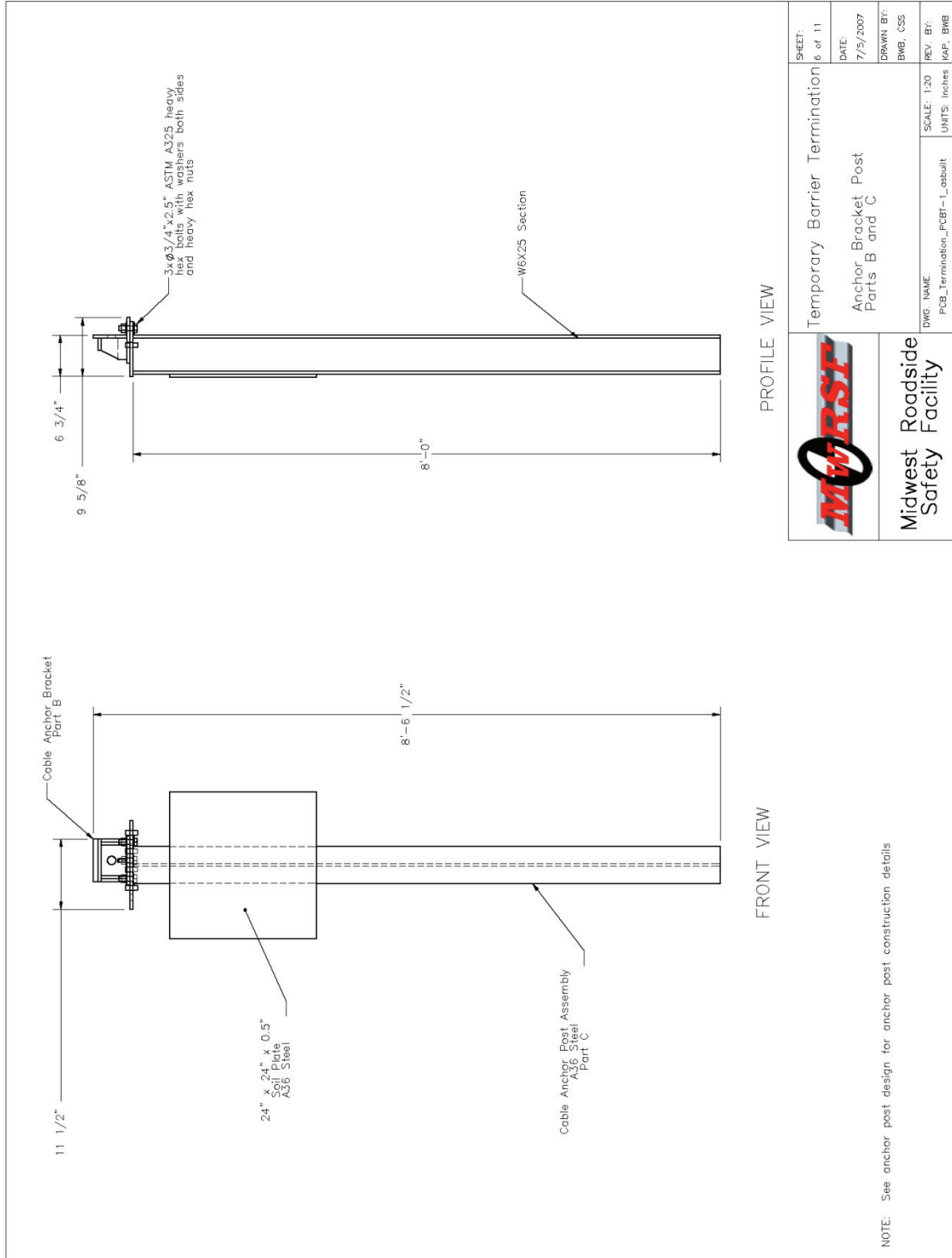

Figure 13. Anchor Bracket Post Details, Test No. TTCB-1

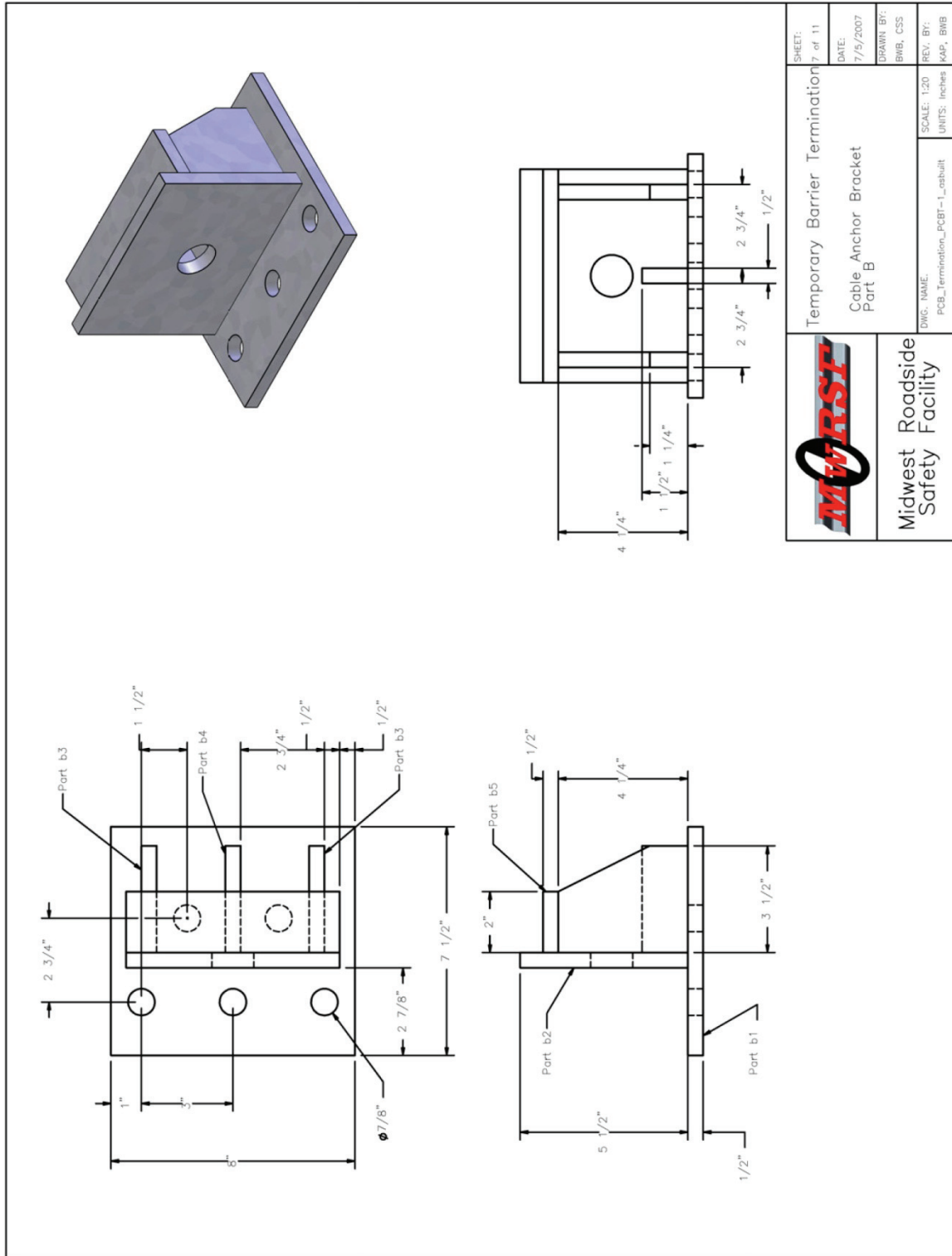

Figure 14. Cable Anchor Bracket Details, Test No. TTCB-1

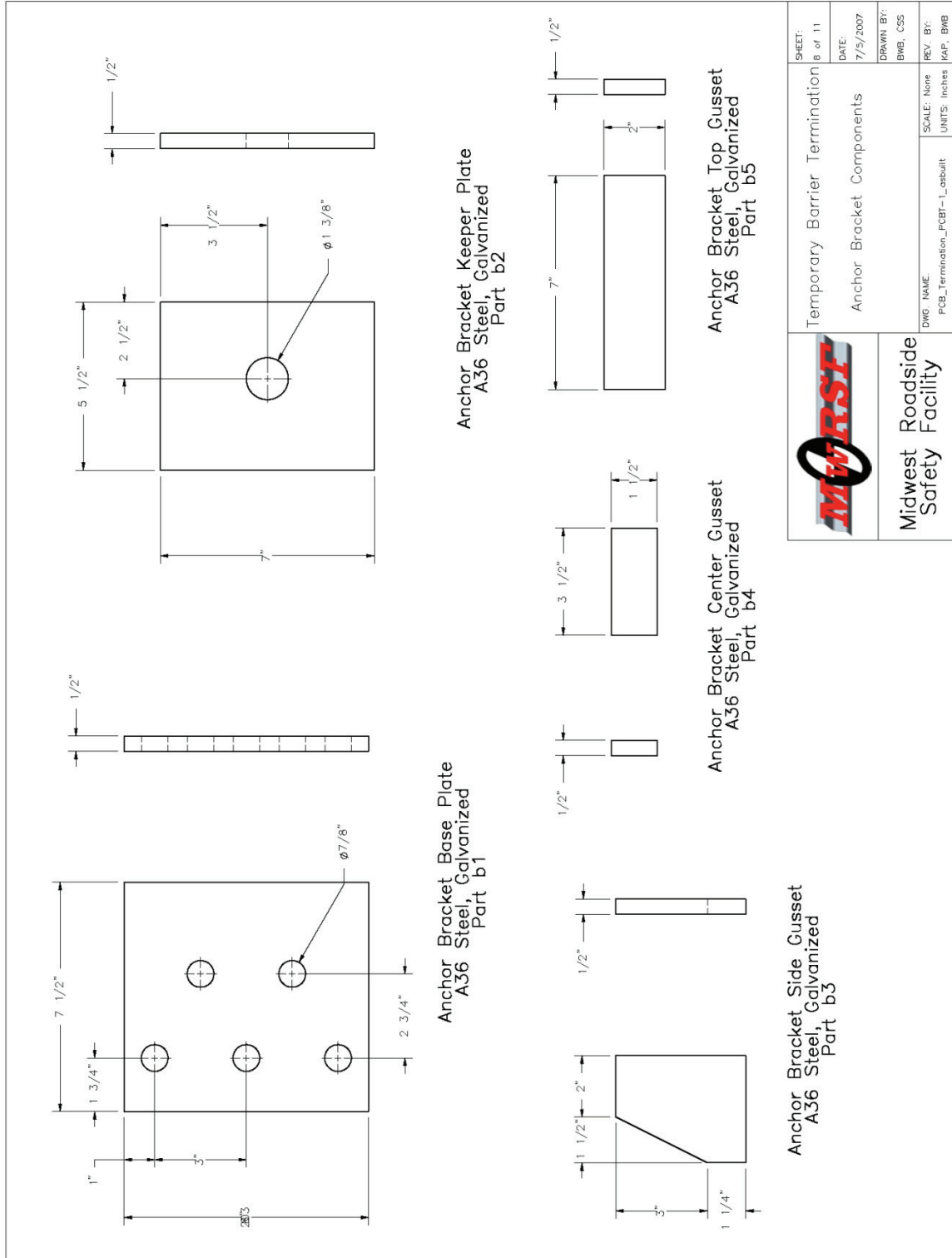

Figure 15. Anchor Bracket Components, Test No. TTCB-1

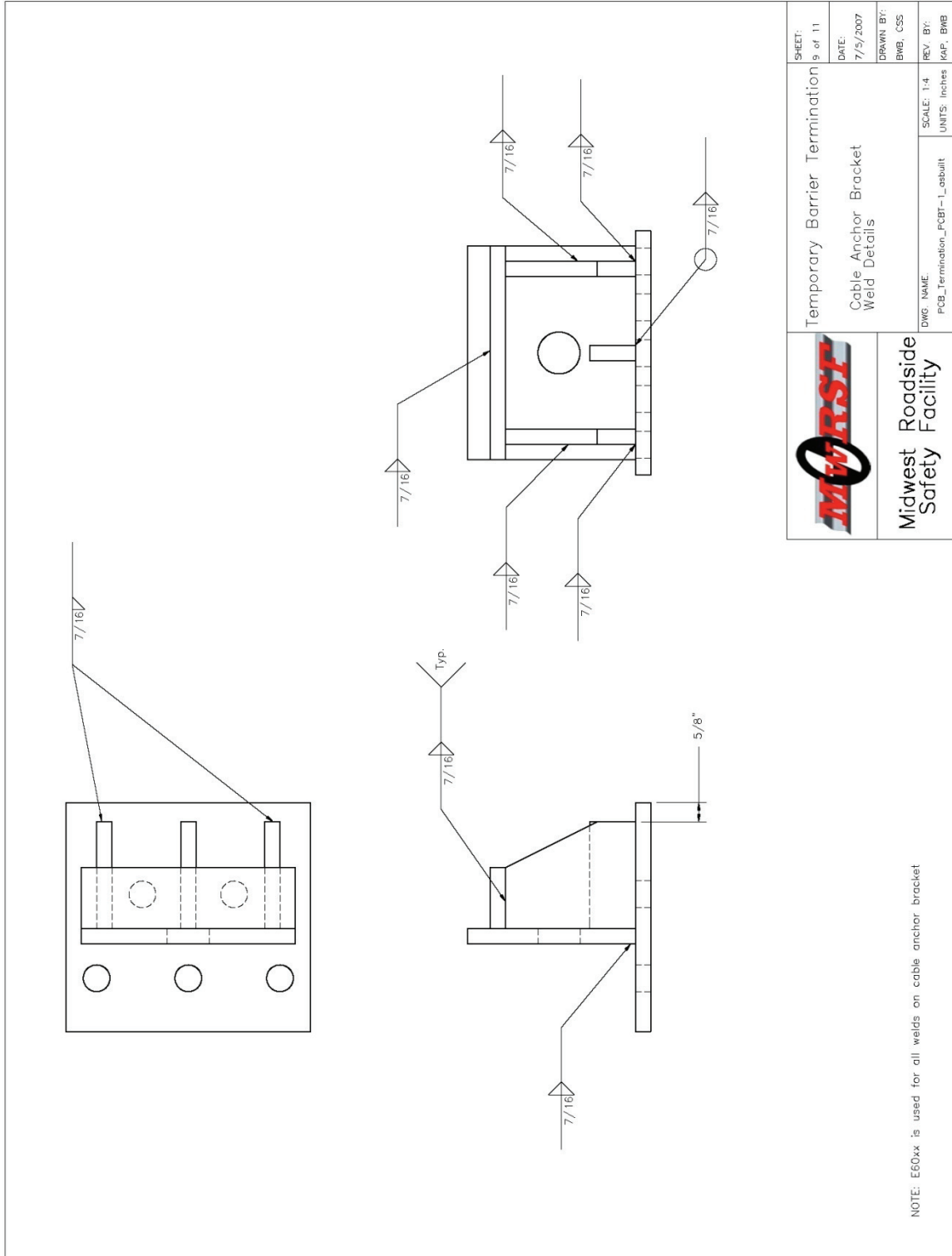

Figure 16. Cable Anchor Bracket Weld Details, Test No. TTCB-1

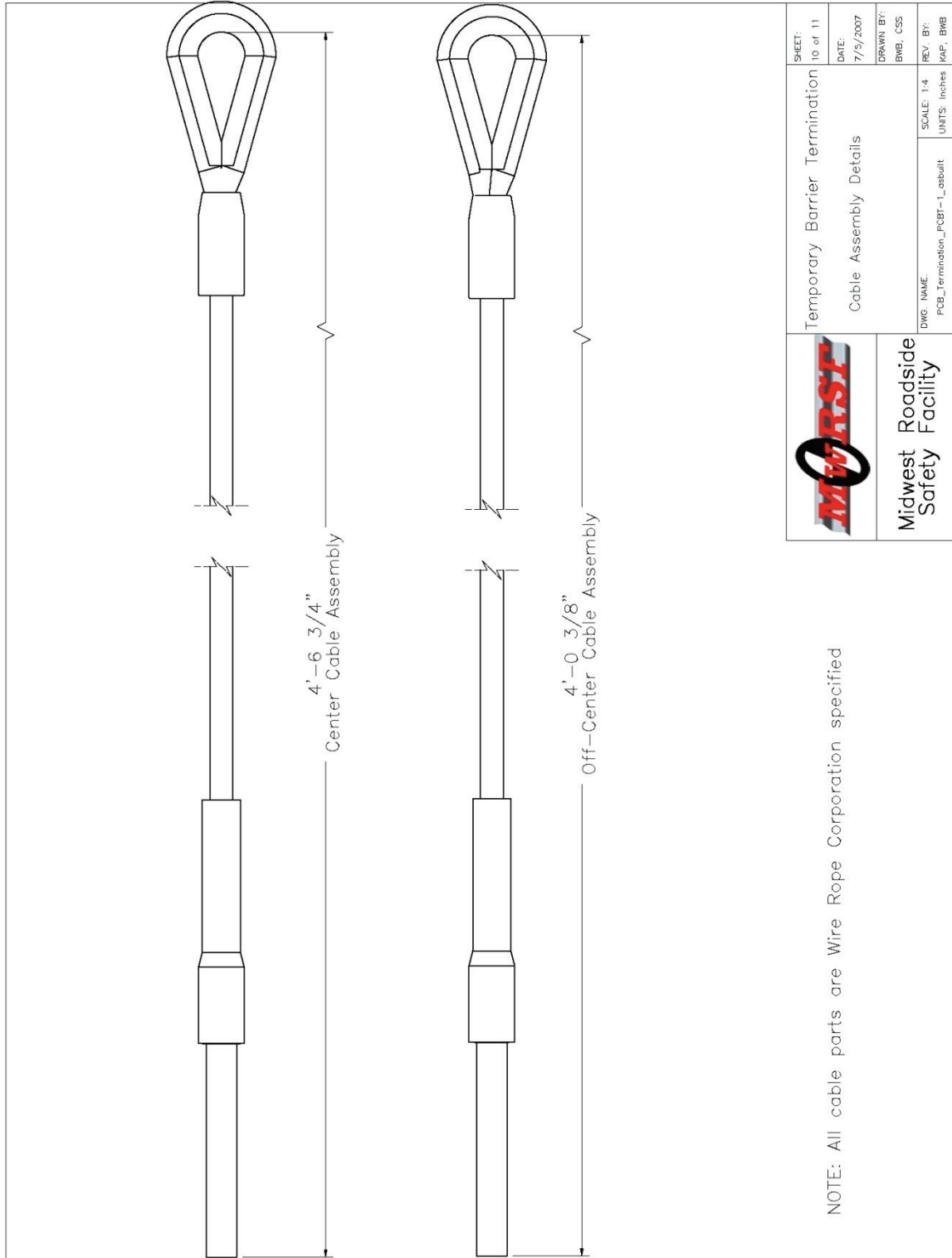
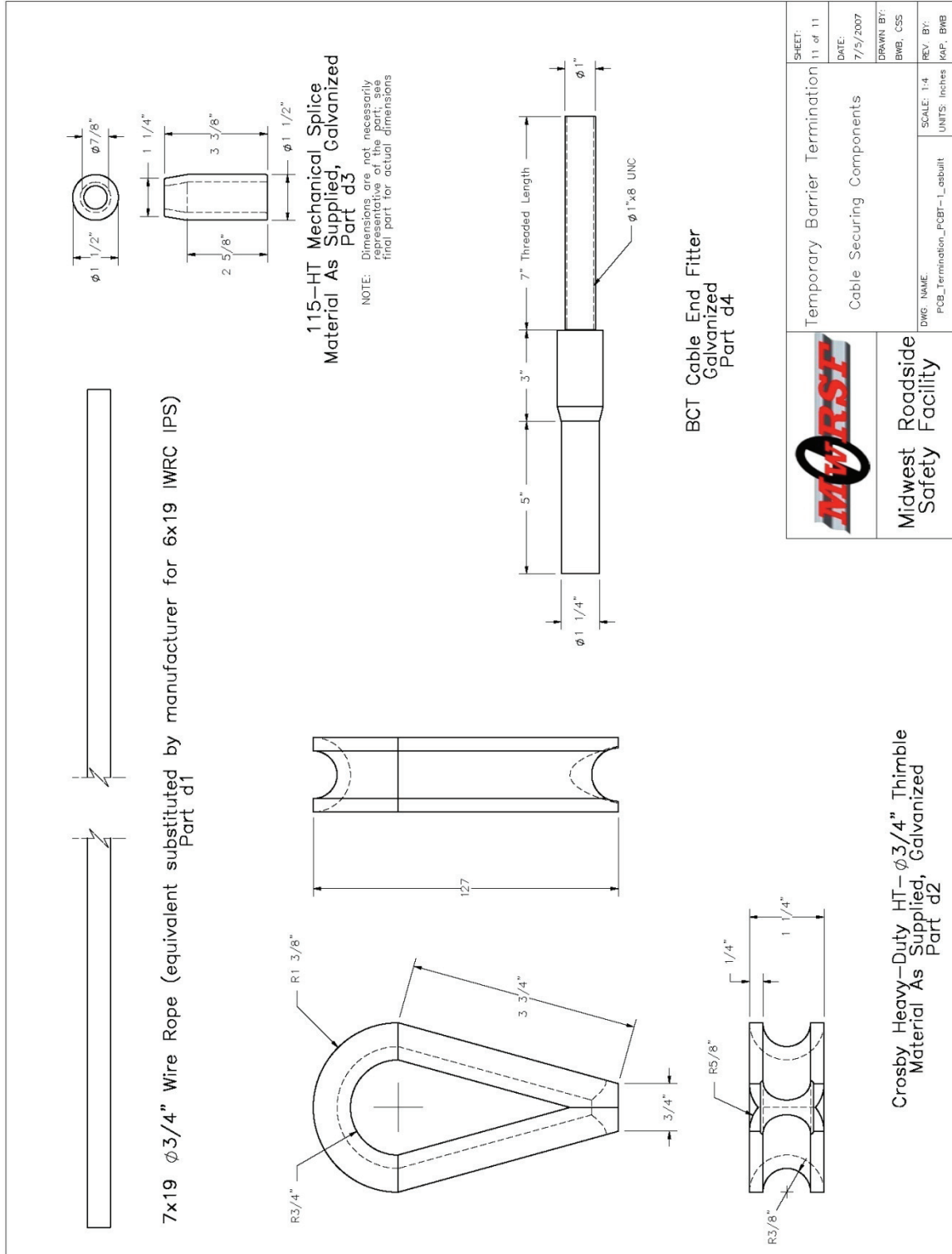

Figure 17. Cable Assembly Details, Test No. TTCB-1



 Midwest Safety Roadside Facility	Temporary Barrier Termination Cable Securing Components	SHEET: 11 of 11 DATE: 7/5/2007 DRAWN BY: BMB, CSS REV. BY: KAP, BMB SCALE: 1:4 UNITS: Inches
	DWG. NAME: PCB_Termination_PCBT-L_asbuilt	

Figure 18. Cable Securing Components, Test No. TTCB-1

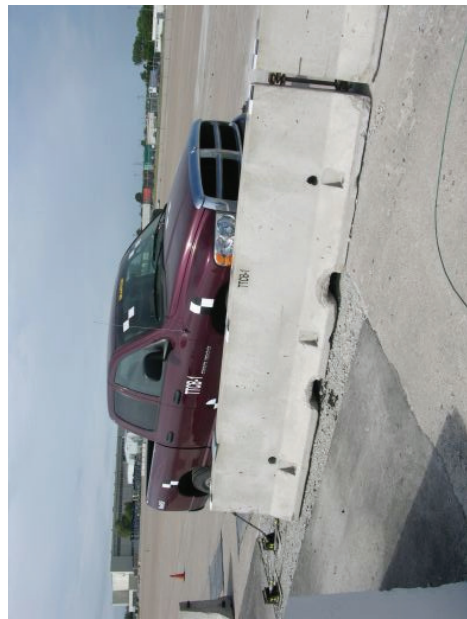

Figure 20. Barrier System Test Installation, Test No. TTCB-1

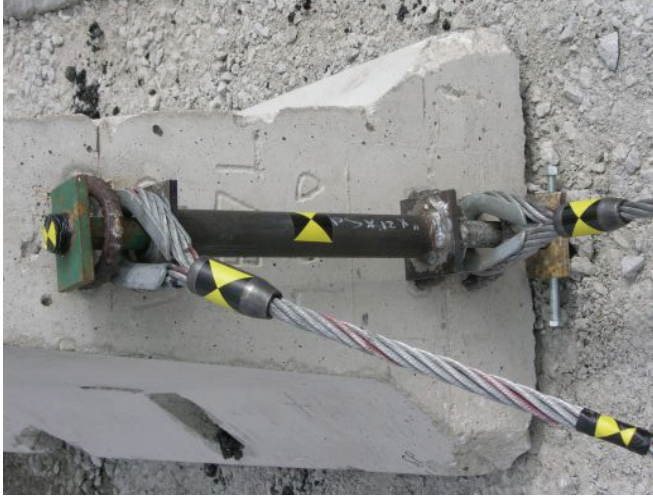

Figure 21. Temporary Barrier Termination Anchorage, Test No. TTCB-1

5 TEST REQUIREMENTS AND EVALUATION CRITERIA

5.1 Test Requirements

Terminals and crash cushions, such as temporary concrete barrier terminations, must satisfy impact safety standards provided in MASH [2], in order to be accepted by the Federal Highway Administration (FHWA) for use on National Highway System (NHS) new construction projects or as a replacement for existing designs not meeting current safety standards. According to Test Level 3 (TL-3) of MASH, non-gating terminals and crash cushions must be subjected to nine full-scale vehicle crash tests. The nine full-scale crash tests are as follows:

1. Test Designation 3-30 consists of a 2,425-lb (1,100-kg) passenger car impacting the terminal at a ¼-pont offset, head-on manner at a nominal speed and angle of 62 mph (100 km/h) and 0 degrees, respectively.
2. Test Designation 3-31 consists of a 5,004-lb (2,270-kg) pickup truck impacting the terminal head-on at a nominal speed and angle of 62 mph (100 km/h) and 0 degrees, respectively.
3. Test Designation 3-32 consists of a 2,425-lb (1,100-kg) passenger car impacting the terminal head-on at a nominal speed and angle of 62 mph (100 km/h) and 5-15 degrees, respectively.
4. Test Designation 3-33 consists of a 5,004-lb (2,270-kg) pickup truck impacting the terminal head at a nominal speed and angle of 62 mph (100 km/h) and 5-15 degrees, respectively.
5. Test Designation 3-34 consists of a 2,425-lb (1,100-kg) passenger car impacting the terminal at the critical impact point (CIP) location transitioning between gating or capturing and redirection at a nominal speed and angle of 62 mph (100 km/h) and 15 degrees, respectively.
6. Test Designation 3-35 consists of a 5,004-lb (2,270-kg) pickup truck impacting the terminal at the beginning of the length of need at a nominal speed and angle of 62 mph (100 km/h) and 25 degrees, respectively.
7. Test Designation 3-36 consists of a 5,004-lb (2,270-kg) pickup truck impacting the terminal at the CIP for the transition to a rigid backup structure at a nominal speed and angle of 62 mph (100 km/h) and 25 degrees, respectively.

8. Test Designation 3-37 consists of a 5,004-lb (2,270-kg) pickup truck impacting the terminal at the CIP for the reverse direction at a nominal speed and angle of 62 mph (100 km/h) and 25 degrees, respectively.
9. Test Designation 3-38 consists of a 3,307-lb (1,500-kg) intermediate car impacting the terminal head-on at a nominal speed and angle of 62 mph (100 km/h) and 0 degrees, respectively.

The temporary concrete barrier termination and anchorage system, as described in Chapter 4, was designed with the intention of either placing an approved impact attenuator, such as sand barrels, in front of the anchorage posts or placing the anchorage system outside of the clear zone. The termination and anchorage system detailed herein was intended to be used in conjunction with a crash tested and FHWA-approved impact attenuator. However, most of the crash tests for terminals and crash cushions that are required in the MASH test matrix do not need to be conducted because they have been previously addressed in the prior successful compliance testing programs. Placement of the termination and anchorage system outside of the clear zone would also negate the need for the majority of the required terminal and crash cushion tests. Tests 3-30 through 3-33 and 3-38 are used to evaluate vehicle stability and containment issues related to impacts at the head of a crash cushion. Tests 3-34 and 3-36 evaluate the front end of crash cushions for either their behavior when impacted at a critical impact point or for transitioning to rigid barriers, respectively. Thus, both tests are not intended to evaluate the safety performance of the concrete barrier or termination anchor system.

Test 3-37 is used to evaluate a crash cushion during reverse direction impacts. However, as discussed in Chapter 2, the barrier system is often flared away from the traveled way and out of the clear zone in roadside applications, thus not requiring an impact attenuator. In the occasion that the end of the barrier is inside the clear zone, an appropriate crash attenuator would be required. However, testing the compatibility of every crash attenuator on the market is not within

the scope of this project. Rather, the manufacturer of a specific crash attenuator is responsible for proving satisfactory crash results during reverse impacts. Therefore, only test 3-35 was deemed applicable for evaluating temporary concrete barrier termination and anchorage system. It should be noted that recommendations are given in Chapter 9 of this report with regards to reverse-direction impacts as well as for the use of sand barrel crash attenuators in conjunction with the end termination and anchorage system. Sand barrel crash cushions are widely used to shield the end of temporary concrete barrier systems, but these devices have not been tested under reverse-direction impact conditions to date.

The test conditions of TL-3 non-gating terminals are summarized in Table 1. It should be noted that while the MASH safety requirements are not yet mandatory for the design of new hardware, it has been the policy of the Midwest States' Regional Pooled Fund Program to develop new hardware to the new criteria voluntarily in order to further improve the design of their roadside safety hardware.

5.2 Evaluation Criteria

Evaluation criteria for full-scale vehicle crash testing are based on three appraisal areas: (1) structural adequacy; (2) occupant risk; and (3) vehicle trajectory after collision. Criteria for structural adequacy are intended to evaluate the ability of the system to redirect the vehicle, stop the vehicle in a controlled manner, or permit the vehicle to safely break through the device. Occupant risk evaluates the degree of hazard to occupants in the impacting vehicle. Vehicle trajectory after collision is a measure of the potential for the post-impact trajectory of the vehicle to become involved in secondary collisions with other vehicles or fixed objects. These evaluation criteria are summarized in Table 2 and are defined in greater detail in MASH. The full-scale

vehicle crash test was conducted and reported in accordance with the procedures provided in MASH.

Table 1. MASH Test Level 3 Crash Test Conditions

Test Article	Test Designation	Test Vehicle	Impact Conditions			Evaluation Criteria ¹
			Speed		Angle (deg.)	
			mph	km/h		
Terminals and Redirective Crash Cushions	3-30	1100C	62	100	0	C,D,F,H,I,N
	3-31	2270P	62	100	0	C,D,F,H,I,N
	3-32	1100C	62	100	5-15	C,D,F,H,I,N
	3-33	2270P	62	100	5-15	C,D,F,H,I,N
	3-34	1100C	62	100	15	C,D,F,H,I,N
	3-35	2270P	62	100	25	A,D,F,H,I
	3-36	2270P	62	100	25	A,D,F,H,I
	3-37	2270P	62	100	25	C,D,F,H,I,N
	3-38	1500A	62	100	0	C,D,F,H,I,N

¹ Evaluation criteria explained in Table 2.

Table 2. MASH Evaluation Criteria for Crash Testing

Structural Adequacy	A.	Test article should contain and redirect the vehicle or bring the vehicle to a controlled stop; the vehicle should not penetrate, underride, or override the installation although controlled lateral deflection of the test article is acceptable		
	C.	Acceptable test article performance may be by redirection, controlled penetration, or controlled stopping of the vehicle.		
Occupant Risk	D.	Detached elements, fragments or other debris from the test article should not penetrate or show potential for penetrating the occupant compartment, or present an undue hazard to other traffic, pedestrians, or personnel in a work zone. Deformations of, or intrusions into, the occupant compartment should not exceed limits set forth in Section 5.3 and Appendix E of MASH.		
	F.	The vehicle should remain upright during and after collision. The maximum roll and pitch angles are not to exceed 75 degrees.		
	H.	Occupant Impact Velocities (OIV) (see Appendix A, Section A5.3 of MASH for calculation procedure) should satisfy the following limits:		
		Occupant Impact Velocity Limits, ft/s (m/s)		
		Component	Preferred	Maximum
	Longitudinal and Lateral	30 ft/s (9.1 m/s)	40 ft/s (12.2 m/s)	
	I.	The Occupant Ridedown Acceleration (ORA) (see Appendix A, Section A5.3 of MASH for calculation procedure) should satisfy the following limits:		
		Occupant Ridedown Acceleration Limits (g's)		
		Component	Preferred	Maximum
		Longitudinal and Lateral	15.0 g's	20.49 g's
Vehicle Trajectory	N.	Vehicle trajectory behind the test article is acceptable.		

6 TEST CONDITIONS

6.1 Test Facility

The testing facility is located at the Lincoln Air Park on the northwest side of the Lincoln Municipal Airport and is approximately 5 miles (8.0 km) northwest of the University of Nebraska-Lincoln.

6.2 Vehicle Tow and Guidance System

A reverse cable tow system with a 1:2 mechanical advantage was used to propel the test vehicle. The distance traveled and the speed of the tow vehicle were one-half that of the test vehicle. The test vehicle was released from the tow cable before impact with the barrier system. A digital speedometer on the tow vehicle increased the accuracy of the test vehicle impact speed.

A vehicle guidance system developed by Hinch [13] was used to steer the test vehicle. A guide-flag, attached to the left-front wheel and the guide cable, was sheared off before impact with the barrier system. The 0.375-in. (9.5-mm) diameter guide cable was tensioned to approximately 3,500 lbf (15.6 kN) and supported both laterally and vertically every 100 ft (30.48 m) by hinged stanchions. The hinged stanchions stood upright while holding up the guide cable, but as the vehicle was towed down the line, the guide-flag struck and knocked each stanchion to the ground. For test no. TTCB-1, the vehicle guidance system was 975 ft (297 m) long.

6.3 Test Vehicles

For test no. TTCB-1, a 2003 Dodge Ram 1500 Quad Cab pickup truck was used as the test vehicle. The test inertial and gross static weights were both 4,991 lbs (2,264 kg). The test vehicle is shown in Figure 22, and vehicle dimensions are shown in Figure 23.



Figure 22. Test Vehicle, Test No. TTCB-1

Date: 6/27/2007 Test Number: TTCB-1 Model: Ram 1500 Q.C.
Make: Dodge Vehicle I.D.#: 1D7HA18N53S139562
Tire Size: 265/70 R17 Year: 2003 Odometer: 103855

*(All Measurements Refer to Impacting Side)

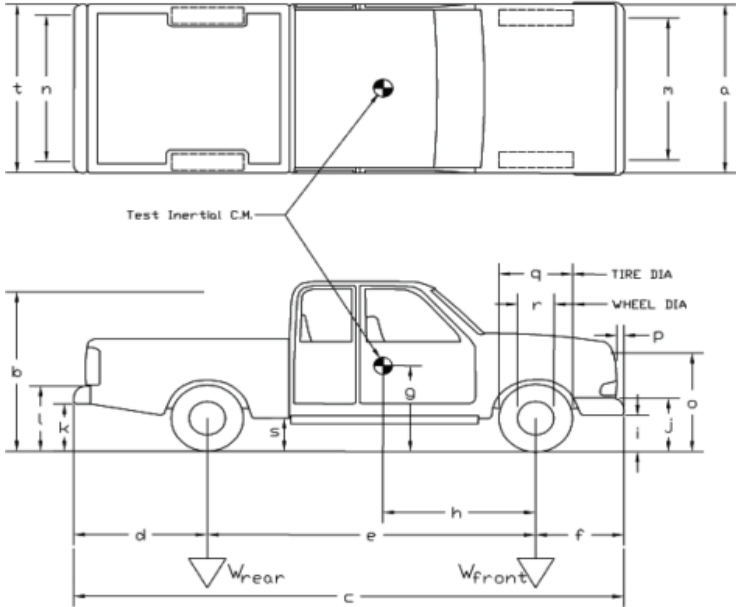

Vehicle Geometry -- in. (mm)

a	<u>78</u>	<u>(1981)</u>	b	<u>75</u>	<u>(1905)</u>
c	<u>227.25</u>	<u>(5772)</u>	d	<u>47</u>	<u>(1194)</u>
e	<u>140.25</u>	<u>(3562)</u>	f	<u>40</u>	<u>(1016)</u>
g	<u>28.2</u>	<u>(716)</u>	h	<u>26.25</u>	<u>(667)</u>
i	<u>29.75</u>	<u>(756)</u>	j	<u>26.75</u>	<u>(679)</u>
k	<u>21</u>	<u>(533)</u>	l	<u>15</u>	<u>(381)</u>
m	<u>68</u>	<u>(1727)</u>	n	<u>67.75</u>	<u>(1721)</u>
o	<u>43.25</u>	<u>(1099)</u>	p	<u>3.5</u>	<u>(89)</u>
q	<u>31</u>	<u>(787)</u>	r	<u>18.5</u>	<u>(470)</u>
s	<u>16</u>	<u>(406)</u>	t	<u>75.25</u>	<u>(1911)</u>
Wheel Center Height Front	<u>15.25 (387)</u>		Wheel Center Height Rear	<u>15.125 (384)</u>	
Wheel Well Clearance (FR)	<u>35.75 (908)</u>		Wheel Well Clearance (RR)	<u>38 (965)</u>	
Frame Height (FR)	<u>28.55 (725)</u>		Frame Height (RR)	<u>18 (457)</u>	
Engine Type	<u>8 CYL. GAS</u>		Engine Size	<u>4.7L</u>	

Transmission Type:
Automatic
RWD

Weights lbs (kg)	Curb	Test Inertial	Gross Static
W-front	<u>2789 (1265)</u>	<u>2774 (1258)</u>	<u>2774 (1258)</u>
W-rear	<u>2199 (997)</u>	<u>2217 (1006)</u>	<u>2217 (1006)</u>
W-total	<u>4988 (2263)</u>	<u>4991 (2264)</u>	<u>4991 (2264)</u>

Front GVWR	<u>3650</u>
Rear GVWR	<u>3900</u>
Total GVWR	<u>6650</u>

Note any damage prior to test: None

Figure 23. Vehicle Dimensions, Test No. TTCB-1

The Suspension Method [14] was used to determine the vertical component of the center of gravity (c.g.) for the pickup truck. This method is based on the principle that the c.g. of any freely suspended body is in the vertical plane through the point of suspension. The vehicle was suspended successively in three positions, and the respective planes containing the c.g. were established. The intersection of these planes pinpointed the location of the c.g. The longitudinal component of the c.g. was also determined using the measured axle weights. The locations of the final centers of gravity are shown in Figures 23 and 24. Data used to calculate the location of the c.g. is shown in Appendix B.

Square black and white-checkered targets were placed on the vehicle to aid in the analysis of the high-speed AOS videos, as shown in Figure 24. Round, checkered targets were placed on the center of gravity, on the left-side door, on the right-side door, and on the roof of the vehicle. The remaining targets were located for references so that they could be viewed from the high-speed cameras for video analysis.

The front wheels of the test vehicle were aligned for camber, caster, and toe-in values of zero so that the vehicles would track properly along the guide cable. A 5B flash bulb was mounted on the left-side of the vehicle's dash to pinpoint the time of impact with the barrier system on the high-speed videos. The flash bulb was fired by a pressure tape switch mounted on the front face of the bumper. A remote controlled brake system was installed in the test vehicle so the vehicle could be brought safely to a stop after the test.

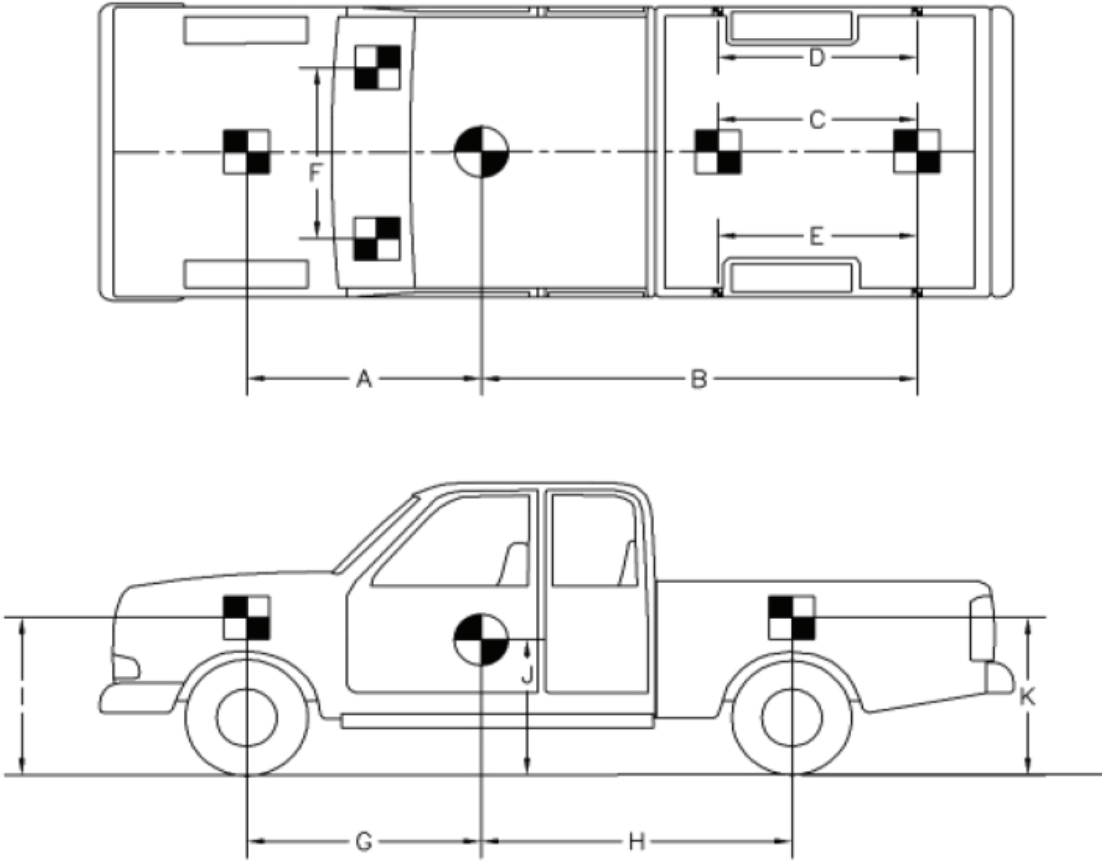

TEST #: <u>TTCB-1</u>					
TARGET GEOMETRY-- in. (mm)					
A	<u>68</u>	<u>(1727)</u>	E	<u>64</u>	<u>(1626)</u>
B	<u>106.25</u>	<u>(2699)</u>	F	<u>40</u>	<u>(1016)</u>
C	<u>48</u>	<u>(1219)</u>	G	<u>62.25</u>	<u>(1581)</u>
D	<u>64</u>	<u>(1626)</u>	H	<u>114</u>	<u>(2896)</u>
I	<u>39.5</u>	<u>(1003)</u>	J	<u>28.25</u>	<u>(718)</u>
K	<u>42.5</u>	<u>(1080)</u>			

Figure 24. Target Geometry, Test No. TTCB-1

6.4 Data Acquisition Systems

6.4.1 Accelerometers

Two environmental shock and vibration sensor/recorder systems were used to measure the accelerations in the longitudinal, lateral, and vertical directions. One triaxial piezoresistive accelerometer system, Model EDR-4M6, was developed by Instrumented Sensor Technology (IST) of Okemos, Michigan and includes three differential channels as well as three single-ended channels. The EDR-4 was configured with 6 MB of RAM memory, a range of ± 200 g's, a sample rate of 10,000 Hz and a 1,500 Hz lowpass filter.

Another triaxial piezoresistive accelerometer system, Model EDR-3, was also developed by Instrumented Sensor Technology (IST) of Okemos, Michigan. The EDR-3 was configured with 256 kB of RAM memory, a range of ± 200 g's, a sample rate of 3,200 Hz, and a 1,120 Hz lowpass filter. Data from both EDR accelerometers was analyzed and plotted using "DynaMax 1 (DM-1)", "DADiSP", and a customized Microsoft Excel spreadsheets. Both accelerometer systems were mounted near the center of gravity of the test vehicle.

6.4.2 Rate Transducers

An Analog Systems 3-axis rate transducer with a range of 1,200 degrees/sec in each of the three directions (roll, pitch, and yaw) was used to measure the rates of motion of the test vehicles. The rate transducer was mounted inside the body of the EDR-4M6 and recorded data at 10,000 Hz to a second data acquisition board inside the EDR-4M6 housing. The raw data measurements were then downloaded, converted to the appropriate Euler angles for analysis, and plotted. Computer software, "DynaMax 1" and "DADiSP," was used to analyze and plot the rate transducer data.

6.4.3 Pressure Tape Switches

For test no. TTCB-1, five pressure-activated tape switches, spaced at 6.56-ft (2-m) intervals, were used to determine the speed of the vehicle before impact. Each tape switch fired a strobe light which sent an electronic timing signal to the data acquisition system as the right-front tire of the test vehicle passed over it. Test vehicle speeds were determined from electronic timing mark data recorded using TestPoint software. Strobe lights and high-speed video analysis are used only as a backup in the event that vehicle speeds cannot be determined from the electronic data.

6.4.4 High Speed Photography

Four high-speed AOS VITcam digital video cameras, four JVC digital video cameras, and two Canon digital video cameras were utilized to film test no. TTCB-1. Camera details, lens information, and camera operating speeds are shown in Table 3. A schematic of the camera locations is shown in Figure 25. The VITcam videos were analyzed using ImageExpress MotionPlus software. Camera speed and camera divergence factors were considered in the analysis of the high-speed videos.

Table 3. Camera and Lens Information, Test No. TTCB-1

	No.	Type	Operating Speed (frames/sec)	Lens	Lens Setting
High-Speed Video	1	AOS Vitcam CTM	500	12.5 mm fixed	
	2	AOS Vitcam CTM	500	Sigma 24-70	60
	3	AOS Vitcam CTM	500	Sigma 70-200	135
	4	AOS Vitcam CTM	500	12.5 mm fixed	
Digital Video	2	JVC Digital Video	29.97		
	3	JVC Digital Video	29.97		
	4	JVC Digital Video	29.97		
	5	JVC Digital Video	29.97		
	7	Canon-ZR90	29.97		
	8	Canon-ZR90	29.97		

6.4.5 String Potentiometers

For test no. TTCB-1, two string potentiometers (linear variable displacement transducers) were installed on the cable anchor brackets to measure the longitudinal displacement of the anchors. The string potentiometers consisted of UniMeasure PA-50 string potentiometers with a range of 50 in. (1,270 mm) and a sample rate of 10,000 Hz. A measurements Group Vishay Model 2310 signal conditioning amplifier was used to condition and amplify the low-level signals to high-level outputs for multichannel, simultaneous dynamic recording on TestPoint software. After each signal was amplified, it was sent to a Keithly Metrabyte DAS-1802HC data acquisition board, and then stored permanently on a personal computer.

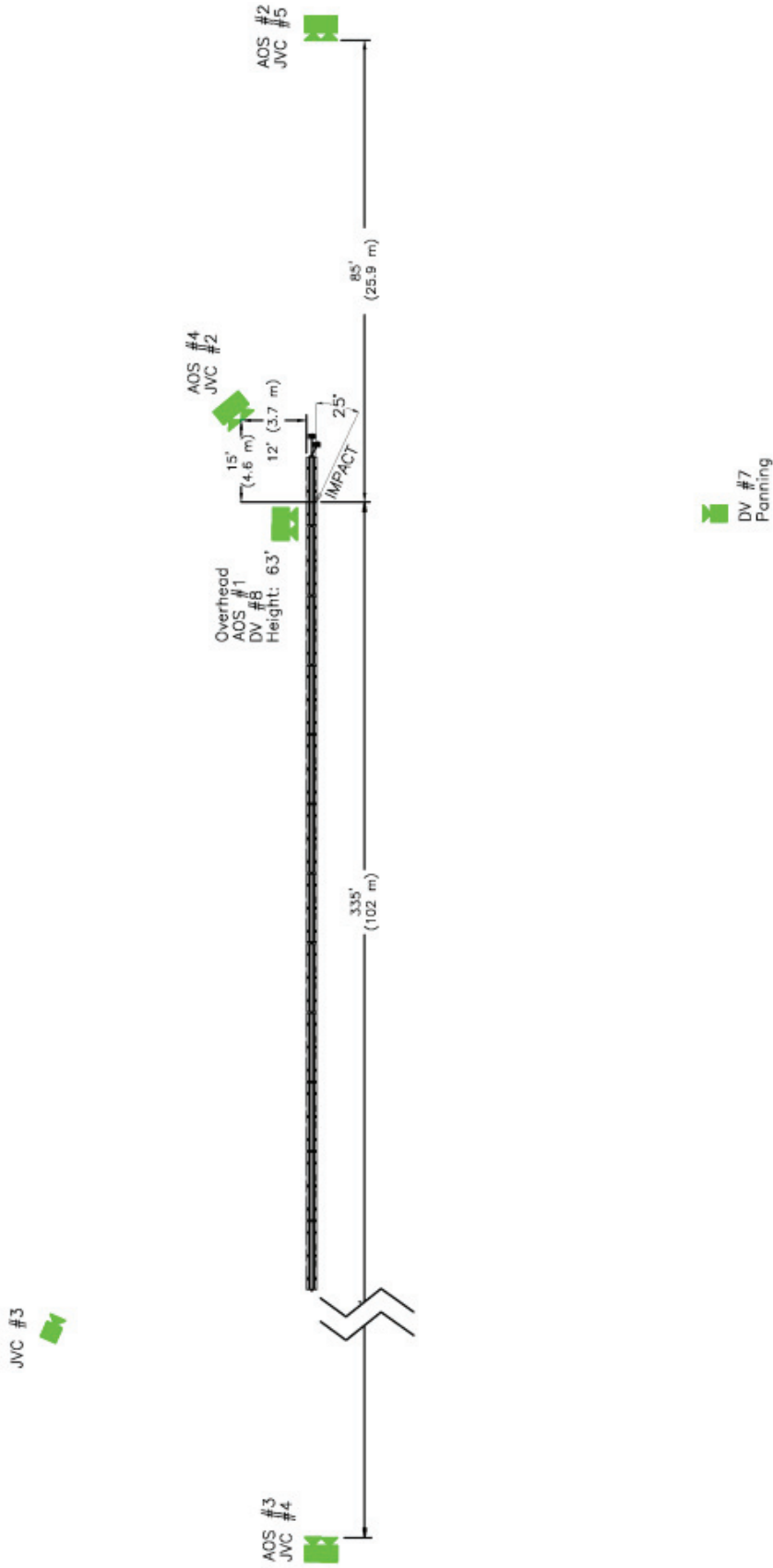

Figure 25. Camera Locations, Test No. TTCB-1

7 FULL-SCALE CRASH TEST NO. TTCB-1

7.1 Test No. TTCB-1

The 4,991-lb (2,264-kg) pickup truck impacted the anchored temporary barrier system at a speed of 62.9 mph (101.2 km/h) and at an angle of 25.5 degrees. A summary of the test results and sequential photographs are shown in Figure 26. The summary of the test results and sequential photographs in metric units are shown in Appendix C. Additional sequential photographs are shown in Figures 27 through 29. Documentary photographs of the crash test are shown in Figure 30.

7.2 Weather Conditions

Test No. TTCB-1 was conducted on June 27th, 2007 at approximately 12:00 pm. The weather conditions were reported as shown in Table 4.

Table 4. Weather Conditions, Test No. TTCB-1

Temperature	81° F
Humidity	44%
Wind Speed	9 mph
Wind Direction	50° from True North
Sky Conditions	Sunny
Visibility	10 Statute Miles
Pavement Surface	Dry
Previous 3-Day Precipitation	0 in.
Previous 7-Day Precipitation	0.15 in.

7.3 Test Description

Initial vehicle impact was to occur 98 3/8 in. (2,499 mm) downstream of the upstream end of barrier no. 1, as shown in Figure 31. The actual point of impact was 10 1/4 in. (260 mm) downstream of the targeted impact. At 0.014 sec after impact, the right-front quarter panel was deformed and began to override the front face of the barrier. At 0.018 sec, barrier no. 1 began to move backward and rotate clockwise (CW) about the anchor. At 0.020 sec, the right-front tire

was riding on the toe of the barrier. At 0.030 sec, the bumper contacted barrier no. 2 as the pickup truck began to redirect. At this same time, barrier no. 2 began to rotate counter-clockwise (CCW), and the anchor cables were pulled tight. At 0.040 sec, the right-front quarter panel had completely passed over the top of the barrier. By 0.050 sec, the vehicle began to yaw CCW and redirect. At 0.056 sec, barrier no. 3 began to rotate CW due to the rotation of barrier no. 2. At 0.060 sec, the offset anchorage post began deflect in the soil and to move downstream, and at 0.070 sec, the soil immediately downstream of the anchor posts was bulging upward. The right-front tire impacted the joint between barrier nos. 1 and 2 at 0.076 sec, and the tire was deflated. At 0.084 sec, part of the right-front paneling detached as both barrier nos. 1 and 2 continued to deflect back. At 0.088 sec, barrier no. 4 began to rotate CCW due to the movement of barrier no. 3. At 0.098 sec, cracks were visible on the backside of barrier no. 2 as the vehicle was pushing on the middle of barrier no. 2. At 0.104 sec, a fragment of concrete broke off from the backside of barrier no. 2. At 0.110 sec, the soil downstream of the anchors continued to rise, and cracks were visible on the ground surface as the anchors moved downstream. At this same time, the truck began to pitch upward. At 0.146 sec, the left-front tire became airborne, and the right head light had separated from the truck. At this same time, barrier no. 3 reversed its rotation from CW to CCW due to the displacement of barrier no. 2. At 0.180 sec, the front bumper impacted barrier no. 3, and barrier no. 4 began to rotate CW. At 0.228 sec, the vehicle was parallel with the system at a speed of 45.2 mph (72.7 km/h) and continued to redirect. At 0.234 sec, soil gaps were visible as the anchors were being pulled downstream. At 0.278 sec, the right-rear tire impacted barrier no. 2. At 0.304 sec, barrier no. 5 began to rotate CW. At 0.394 sec, all of the tires were off the ground, and vehicle's right side impacted barrier no. 4. At 0.628 sec, the right-front quarter panel impacted barrier no. 5. By 0.690 sec, the right-front tire returned to the

ground, and the vehicle began to yaw CW. At 0.756 sec, the front bumper impacted the ground, and at 0.810 sec, the vehicle lost contact with the barrier system at 36.1 mph (58.1 km/h) and an angle of 15.9 degrees. At 0.994 sec, the rear tires impacted the ground, and the right-rear tire detached from the vehicle. At 1.000 sec, the barrier system had stopped deflecting as the pickup truck continued to move downstream and yaw CW until it eventually came to a stop 175 ft – 3 in. (53.42 m) downstream of impact and 5 ft – 4 in. (1.63 m) in front of the barrier system. The trajectory and final position of the vehicle are shown in Figure 32.

7.4 Barrier Damage

Damage to the barrier system was moderate, as shown in Figures 33 through 39. Tire marks were found on barrier no. 1 beginning 95 7/8 in. (2,435 mm) downstream of the upstream end of barrier no. 1 and continued to the downstream end of barrier no. 2. Contact marks from the body of the pickup truck began 108 5/8 in. (2,759 mm) downstream of the upstream end of barrier no. 1 and continued through barrier no. 2. Both the tire and vehicle body marks are shown in Figures 34 and 35. Spalling was found on the barrier edges at the joint between barrier nos. 1 and 2.

The most extensive barrier damage occurred to barrier no. 2, as shown in Figures 35 and 36. Cracks were found through the entire cross section of the barrier spanning the middle 60 in. (1,524 mm) of barrier no. 2. These cracks were typically hairline cracks on the front surface of the barrier, but opened up larger gaps on the back surface. The front-side of barrier no. 2 had two 12-in. wide x 6-in. tall x 4-in. deep (305-mm x 152-mm x 102-mm) concrete pieces break away from the toe near the center of the barrier. Barrier no. 2 was permanently bowed such that the center of the barrier was 3.125 in. (79 mm) off line. Spalling and gouging was found in various areas on the front face of the barrier.

Spalling was also found at the edges of the joint between barrier nos. 2 and 3. Barrier no. 3 contained tire marks beginning 20 in. (508 mm) from the upstream end and continued down the length of the barrier, as shown in Figure 37. A maximum permanent set deflection of 66.5 in. (1,689 mm) was measured at the downstream end of barrier no. 3. No dynamic deflection measurement was available because the barriers were still in motion and the end of the available high-speed video footage taken from the overhead view. Various tire and vehicle body contact marks were found from the middle of barrier no. 4 to the upstream side of barrier no. 5. The remaining barriers remained undamaged.

The soil downstream of the anchor plates was bulged upward and cracked at the ground surface, as shown in Figure 38. A soil gap of 4.75 in. (121 mm) was located on the upstream side of the anchor post in line with the system, as shown in Figure 39. The offset anchor was twisted slightly toward the system. Analysis of the data from the string potentiometer mounted on the anchors showed maximum dynamic anchor deflections of 5.28 in. (134 mm) for the offset anchorage and 6.19 in. (157 mm) for the in-line anchorage. String potentiometer data is located in Appendix F. No visible damage to the anchor cables or cable brackets was observed.

7.5 Vehicle Damage

The damage to the vehicle was moderate, as shown in Figures 40 through 45. The most extensive damage was concentrated at the right-front corner of the pickup truck where the quarter panel was crushed inward. The right side of the front bumper was also crushed in toward the engine compartment, and the right side of the grill was torn apart, as shown in Figure 41. Also, the entire front bumper was shifted downward approximately 2.5 in. (64 mm). The right-front tire was detached from the pickup truck and was resting flat underneath the right-side occupant compartment. The right-front control arm was fractured, and the tie rod had broken off,

as shown in Figure 42. Also, the right-front tire was deflated and received multiple tears in the rubber and deformations to the rim.

The right side of the pickup truck received multiple scratches, gouges, and dents, as shown in Figure 43. The scratches and gouges spanned from the right-front door to the right-rear corner of the vehicle. The right-side doors were dented inward approximately 2 in. (51 mm).

The right-rear tire was also detached from the pickup truck and came to rest approximately 40 ft (12.2 m) to the left of the vehicle. The right-rear disc brake was deformed and fractured, and the brake line was snapped, as shown in Figure 44. The right tail light was detached, and the rear bumper was bowed inward and shifted down.

Occupant compartment deformations to the right front of the floorboard, as shown in Figure 45, were judged insufficient to cause serious injury to the vehicle occupants. A maximum longitudinal deformation of 4 in. (102 mm) was located along the right side of the floorboard. A maximum lateral deformation of 3 in. (76 mm) was located at the front of the right-side floorboard. A maximum vertical deformation of 4.25 in. (108 mm) was located near the right-front corner of the floorboard. Deformations were recorded from two separate locations before and after the test. Complete occupant compartment deformations and the corresponding locations are provided in Appendix D.

7.6 Occupant Risk

From the EDR-3, the longitudinal and lateral occupant impact velocities were determined to be -13.41 ft/s (-4.09 m/s) and -17.15 ft/s (-5.23 m/s), respectively. The maximum 0.010-sec average occupant ridedown accelerations from the EDR-3 in the longitudinal and lateral directions were -16.47 g's and -8.00 g's, respectively. From the EDR-4, the longitudinal and lateral occupant impact velocities were determined to be -14.04 ft/s (-4.28 m/s) and -16.02 ft/s (-

4.88 m/s), respectively. The maximum 0.010-sec average occupant ridedown accelerations from the EDR-4 in the longitudinal and lateral directions were -10.36 g's and -8.04 g's, respectively. It is noted that the occupant impact velocities (OIVs) and occupant ridedown accelerations (ORAs) were within the suggested limits provided in MASH. The maximum roll angles for the vehicle were determined to be -3.13 degrees at 0.155 sec after impact and 14.75 degrees at 0.693 sec after impact. These roll angles are within the suggested roll angle limits provided in MASH. The results of the occupant risk, as determined from the accelerometer data, are summarized in Figure 26. The recorded data from both the accelerometers and the rate transducer are shown graphically in Appendix E.

7.7 Discussion

The analysis of the test results for test no. TTCB-1 showed that the temporary concrete barrier termination and anchorage system adequately contained and redirected the vehicle. There were no detached elements nor fragments which showed potential for penetrating the occupant compartment nor presented undue hazard to other traffic. The deformation of, or intrusion into, the occupant compartment was minimal and did not pose a threat to cause serious injury. The test vehicle did not penetrate nor ride over the barrier and remained upright during and after the collision. Vehicle roll, pitch, and yaw angular displacements were noted, as shown in Appendix E, and were deemed acceptable because they did not adversely influence occupant risk safety criteria nor cause rollover. After impact, the vehicle exited the barrier at an angle of 15.9 degrees and did not intrude into adjacent traffic lanes. Therefore, test no. TTCB-1, conducted on a termination and anchorage system for temporary concrete barrier, was determined to be acceptable according to the TL-3 safety performance criteria found in the MASH using test designation no. 3-35.

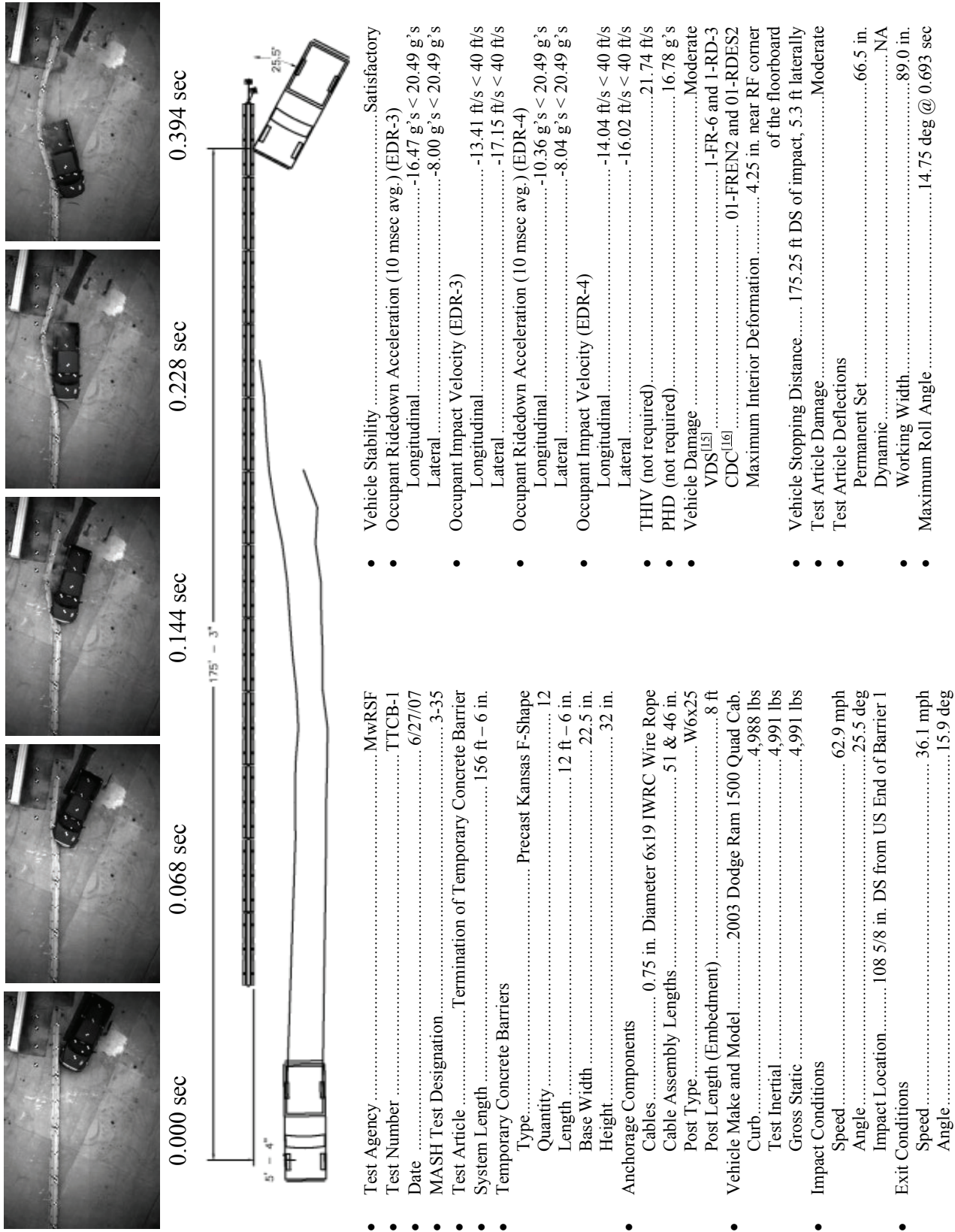

Figure 26. Summary of Test Results and Sequential Photographs, Test No. TTCB-1



0.000 sec



0.054 sec



0.086 sec



0.130 sec



0.228 sec



0.372 sec



0.000 sec



0.112 sec



0.220 sec



0.376 sec



0.690 sec



1.376 sec

Figure 27. Additional Sequential Photographs, Test No. TTCB-1



0.000 sec



0.038 sec



0.070 sec



0.110 sec



0.234 sec



0.392 sec



0.000 sec



0.067 sec



0.200 sec



0.334 sec



0.567 sec



0.734 sec

Figure 28. Additional Sequential Photographs, Test No. TTCB-1



0.000 sec



0.100 sec



0.234 sec



0.400 sec



0.701 sec



1.101 sec



0.000sec



0.067 sec



0.133 sec



0.200 sec



0.334 sec



0.501 sec

Figure 29. Additional Sequential Photographs, Test No. TTCB-1



Figure 30. Documentary Photographs, Test No. TTCB-1

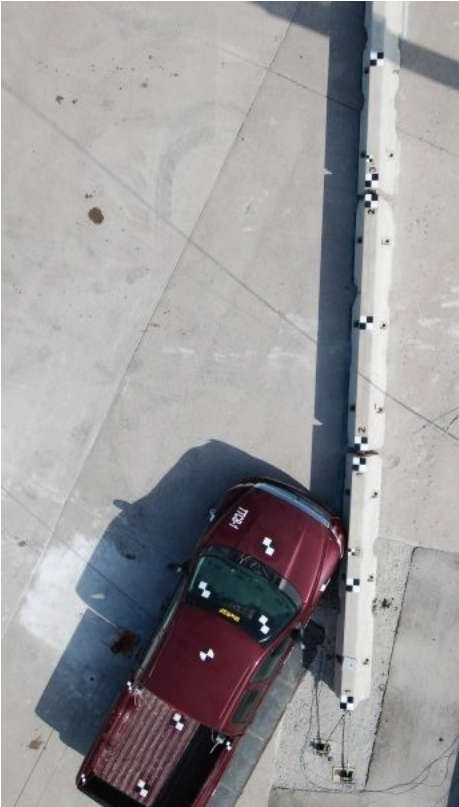

Figure 31. Impact Location, Test No. TTCB-1



Figure 32. Vehicle Final Position and Trajectory Marks, Test No. TTCB-1



Figure 33. System Damage, Test No. TTCB-1



Figure 34. System Damage - Barrier No. 1, Test No. TTCB-1



Figure 35. System Damage - Barrier No. 2, Test No. TTCB-1



Figure 36. System Damage - Back of Barrier No. 2, Test No. TTCB-1



Barrier No. 3



Barrier No. 4



Barrier No. 5

Figure 37. System Damage - Barrier Nos. 3-5, Test No. TTCB-1

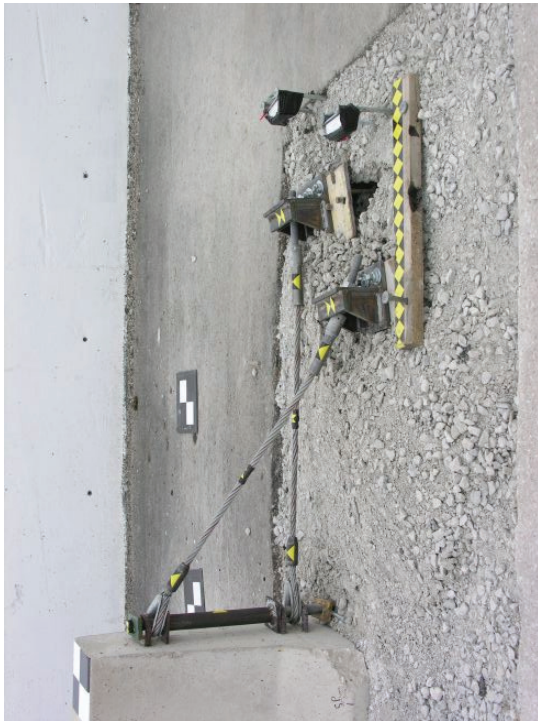

Figure 38. Anchorage Displacement, Test No. TTCB-1



Figure 39. Anchor Posts Displacement, No. Test No. TTCB-1



Figure 40. Vehicle Damage, Test No. TTCB-1



Figure 41. Damage to Right-Front of Vehicle, Test No. TTCB-1

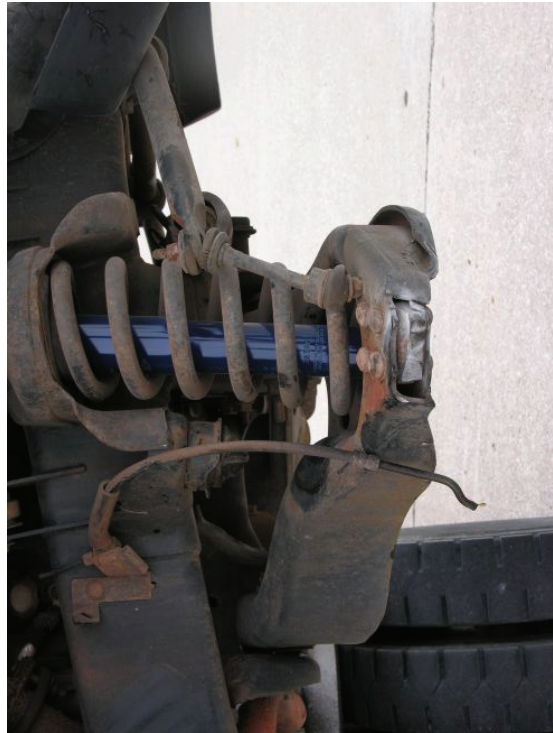

Figure 42. Vehicle Right-Front Wheel Assembly Damage, Test No. TTCB-1



Figure 43. Damage to Right Side of Vehicle, Test No. TTCB-1



Figure 44. Vehicle Right-Rear Wheel Damage, Test No. TTCB-1



Figure 45. Vehicle Damage, Occupant Compartment, Test No. TTCB-1

8 SUMMARY AND CONCLUSIONS

A termination and anchorage system was designed for use with the upstream end of free-standing, temporary concrete barriers and later was evaluated using full-scale vehicle crash testing. This termination and anchorage system allowed for a significant reduction in the number of barrier segments required upstream from the length of need and for use in anchoring a free-standing temporary concrete barrier system. More specifically, the system was designed and tested for use with Kansas F-shape temporary concrete barriers.

System design of the termination and anchorage system began with the identification of the design criteria, including the constraints for the end of the barrier system (i.e., limiting longitudinal motion and rotation about the longitudinal axis of the end barrier segment), utilization of existing hardware to the largest extent possible, as well as the conceptual design of the hardware used to attach to either end of the temporary concrete barrier segment. Next, the researchers used LS-DYNA finite element computer simulation to determine the appropriate design loads for use in configuring the termination and anchorage system. Once the design loads were found, the researchers developed an anchorage system that met both the design criteria and impact loads.

The termination and anchorage system consisted of two cable assemblies that connected the barrier's vertical connector pin to two driven steel anchor posts. Each of the two anchor posts was a 8-ft (2,438-mm) long, W6x25 (W152x37.2) steel section with a 24-in. x 24-in. x 0.5-in. (610-mm x 610-mm x 13-mm) soil plate welded to the front flange and a 0.5-in. (13-mm) thick mounting plate welded to the top of the post. The anchor posts were placed in soil with an embedment depth of 8 ft (2,438 mm). These anchor posts were part of an existing anchor post used previously as an anchorage for a low-tension, three cable guardrail system. The connection

between the anchor posts and the barrier segment was designed as a simple attachment to the vertical steel drop pin which passes through the barrier loop bars. The anchorage system was configured to effectively constrain the end of the temporary concrete barrier system for impacts as far upstream as the first anchored barrier segment. To be successful, the anchorage system was also designed to limit barrier rotations about the longitudinal barrier axis that may promote vehicle instabilities and even rollover.

Test no. TTCB-1 was conducted to evaluate the safety performance of the termination and anchorage system according to test designation no. 3-35 found in MASH. In this test, a 4,991-lb (2,264-kg) pickup truck impacted the anchored temporary concrete barrier system at a speed of 62.9 mph (101.2 km/h) and at an angle of 25.5 degrees on a target impact point 4.3-ft (1.31-m) upstream of the joint between the first and second barriers in the system. The impacting vehicle was safely and smoothly redirected, and the test was judged acceptable according to the TL-3 safety criteria set forth in MASH, as shown in Table 5.

Table 5. Summary of Safety Performance Evaluation Results, Test No. TTCB-1

Evaluation Factors	Evaluation Criteria	Test TTCB-1									
Structural Adequacy	<p>A. Test article should contain and redirect the vehicle or bring the vehicle to a controlled stop; the vehicle should not penetrate, underide, or override the installation although controlled lateral deflection of the test article is acceptable.</p>	S									
	<p>D. Detached elements, fragments or other debris from the test article should not penetrate or show potential for penetrating the occupant compartment, or present an undue hazard to other traffic, pedestrians, or personnel in a work zone. Deformations of, or intrusions into, the occupant compartment should not exceed limits set forth in Section 5.3 and Appendix E of MASH 08.</p>	S									
	<p>F. The vehicle should remain upright during and after collision. The maximum roll and pitch angles are not to exceed 75 degrees.</p>	S									
Occupant Risk	<p>H. Occupant Impact Velocities (OIV) (see Appendix A, Section A5.3 of MASH 08 for calculation procedure) should satisfy the following limits:</p>	S									
	Occupant Impact Velocity Limits, ft/s (m/s)										
	<table border="1"> <thead> <tr> <th data-bbox="828 1020 881 1320">Component</th> <th data-bbox="828 726 881 1020">Preferred</th> <th data-bbox="828 352 881 726">Maximum</th> </tr> </thead> <tbody> <tr> <td data-bbox="881 1020 951 1320">Longitudinal and Lateral</td> <td data-bbox="881 726 951 1020">30 ft/s (9.1 m/s)</td> <td data-bbox="881 352 951 726">40 ft/s (12.2 m/s)</td> </tr> </tbody> </table>		Component	Preferred	Maximum	Longitudinal and Lateral	30 ft/s (9.1 m/s)	40 ft/s (12.2 m/s)			
Component	Preferred	Maximum									
Longitudinal and Lateral	30 ft/s (9.1 m/s)	40 ft/s (12.2 m/s)									
<p>I. The Occupant Ridedown Acceleration (ORA) (see Appendix A, Section A5.3 of MASH 08 for calculation procedure) should satisfy the following limits:</p>	<table border="1"> <thead> <tr> <th colspan="3" data-bbox="951 352 1218 464">Occupant Ridedown Acceleration Limits (g's)</th> </tr> <tr> <th data-bbox="951 1020 1153 1320">Component</th> <th data-bbox="951 726 1153 1020">Preferred</th> <th data-bbox="951 464 1153 726">Maximum</th> </tr> </thead> <tbody> <tr> <td data-bbox="1153 1020 1218 1320">Longitudinal and Lateral</td> <td data-bbox="1153 726 1218 1020">15.0 g's</td> <td data-bbox="1153 464 1218 726">20.49 g's</td> </tr> </tbody> </table>	Occupant Ridedown Acceleration Limits (g's)			Component	Preferred	Maximum	Longitudinal and Lateral	15.0 g's	20.49 g's	S
Occupant Ridedown Acceleration Limits (g's)											
Component	Preferred	Maximum									
Longitudinal and Lateral	15.0 g's	20.49 g's									

S - Satisfactory
U - Unsatisfactory
NA - Not Applicable

9 RECOMENDATIONS

As presented herein, the new termination and anchorage system provides users with increased safety and flexibility during placement of temporary concrete barrier systems. The termination and anchorage system should result in shorter installation lengths for temporary concrete barrier, fewer vehicle impacts into the barrier, and an overall reduction in the cost of the installation. While this research and development effort was successful, there are some comments that need to be made regarding implementation of the new system.

The system details, as shown in previous sections of this report, represented the as-built, as-tested system. These details differ slightly from the final recommended details shown in Figure 46 through Figure 57. Metric details are shown in Appendix A. First, the final system details were configured with slightly different anchor post positions than those evaluated by the full-scale test. The anchor posts used in the full-scale crash test were placed before the entire system was configured and were not in an optimal position. For the final design, the anchor posts were moved slightly, but the change in position is not believed to negatively affect the system's safety performance. Second, a repositioning of the anchor posts also resulted in the need to modify the lengths of the cable assemblies. Finally, the barrier system was installed at an angle to one of MwRSF's soil test pits in order to provide an achievable tow distance and impact angle for use in the crash test. The end barrier in this test installation was placed with approximately three quarters of the barrier resting on the same soil foundation that surrounded the anchor posts. Actual field installations of the termination and anchorage system would not require the same soil area for use in placing the first barrier segment nor the anchorage posts. It is recommended that the anchor posts be installed in a soil foundation. However, the required size of the soil area must be sufficient for the anchors to be embedded in the soil and resist the dynamic loads

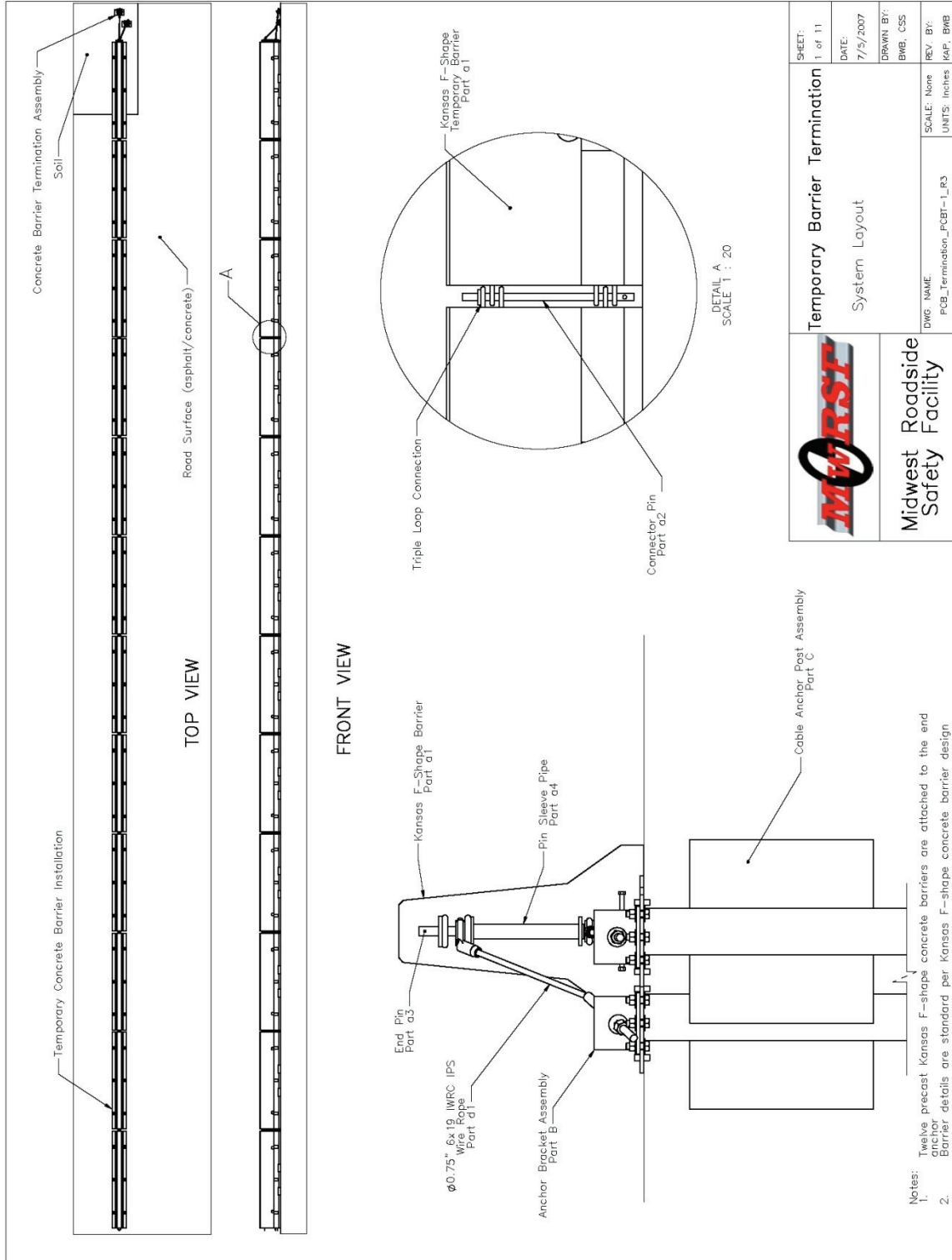
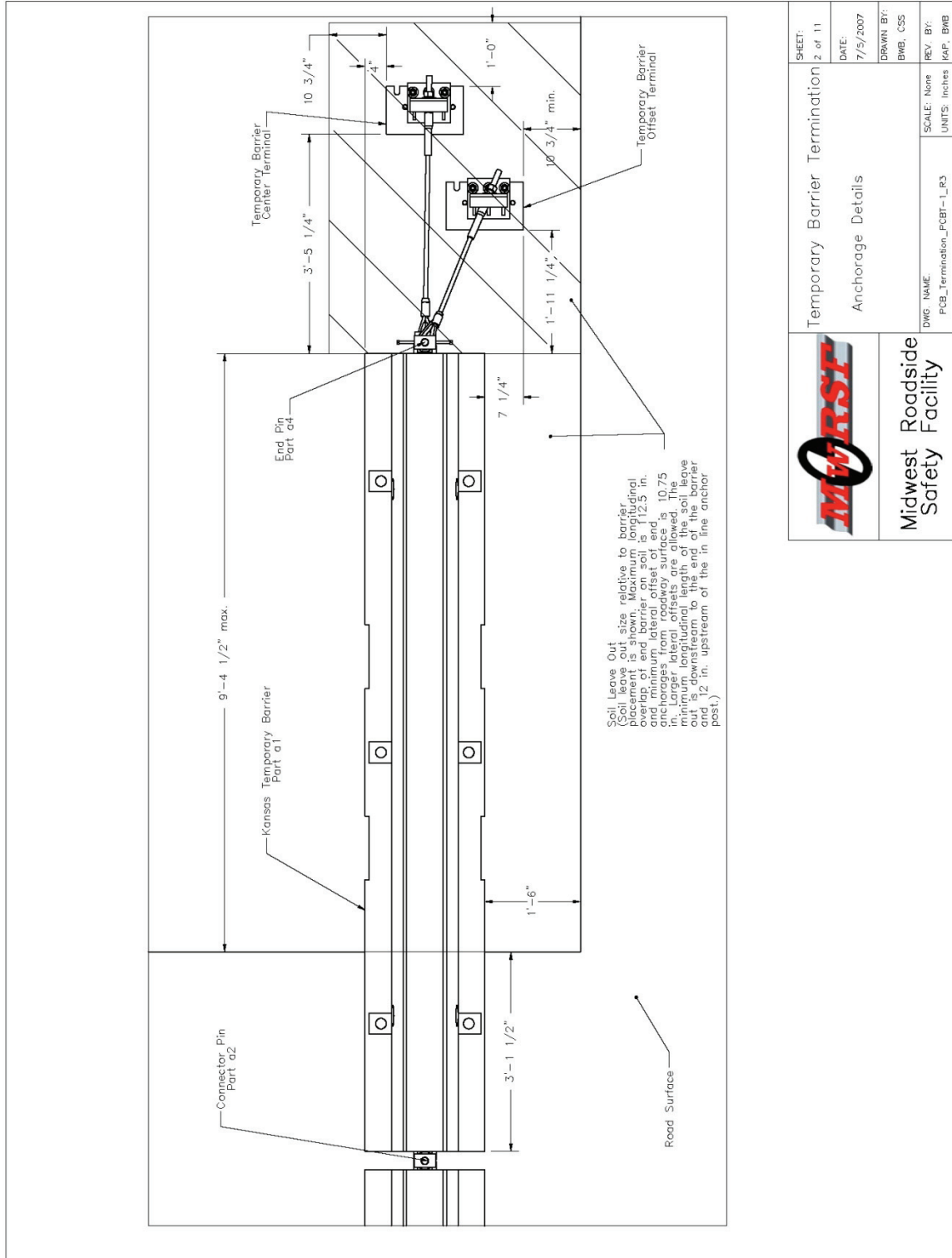

Figure 46. Termination of Temporary Concrete Barrier, Final Design Details



 Midwest Roadside Safety Facility	SHEET: 2 of 11 DATE: 7/5/2007 DRAWN BY: BMB, CCS DWG. NAME: PCB_Termination_FCBT-L_R3 SCALE: None UNITS: Inches
	Temporary Barrier Termination Anchorage Details

Figure 47. Termination of Temporary Concrete Barrier, Final Design Details

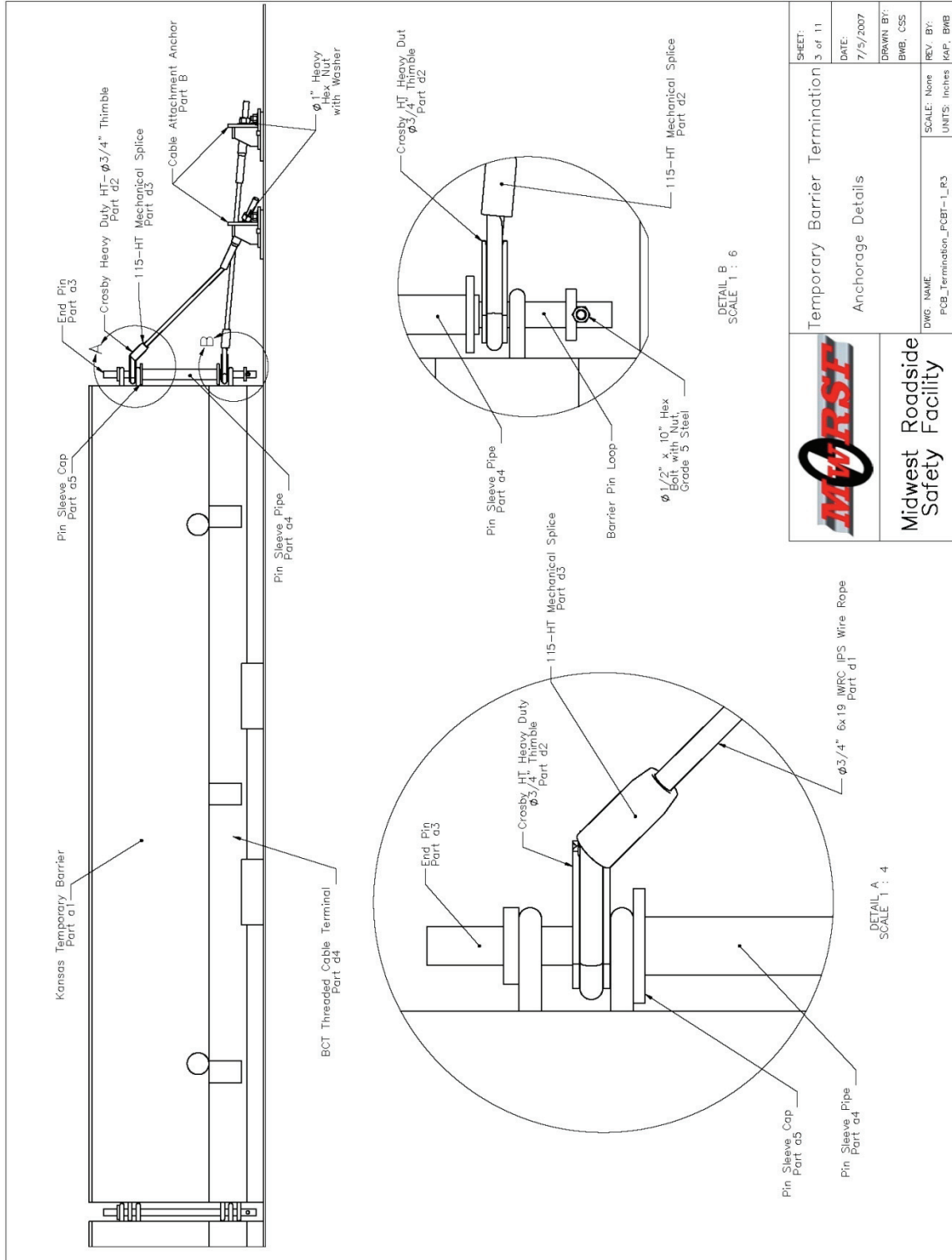

Figure 48. Termination of Temporary Concrete Barrier, Final Design Details

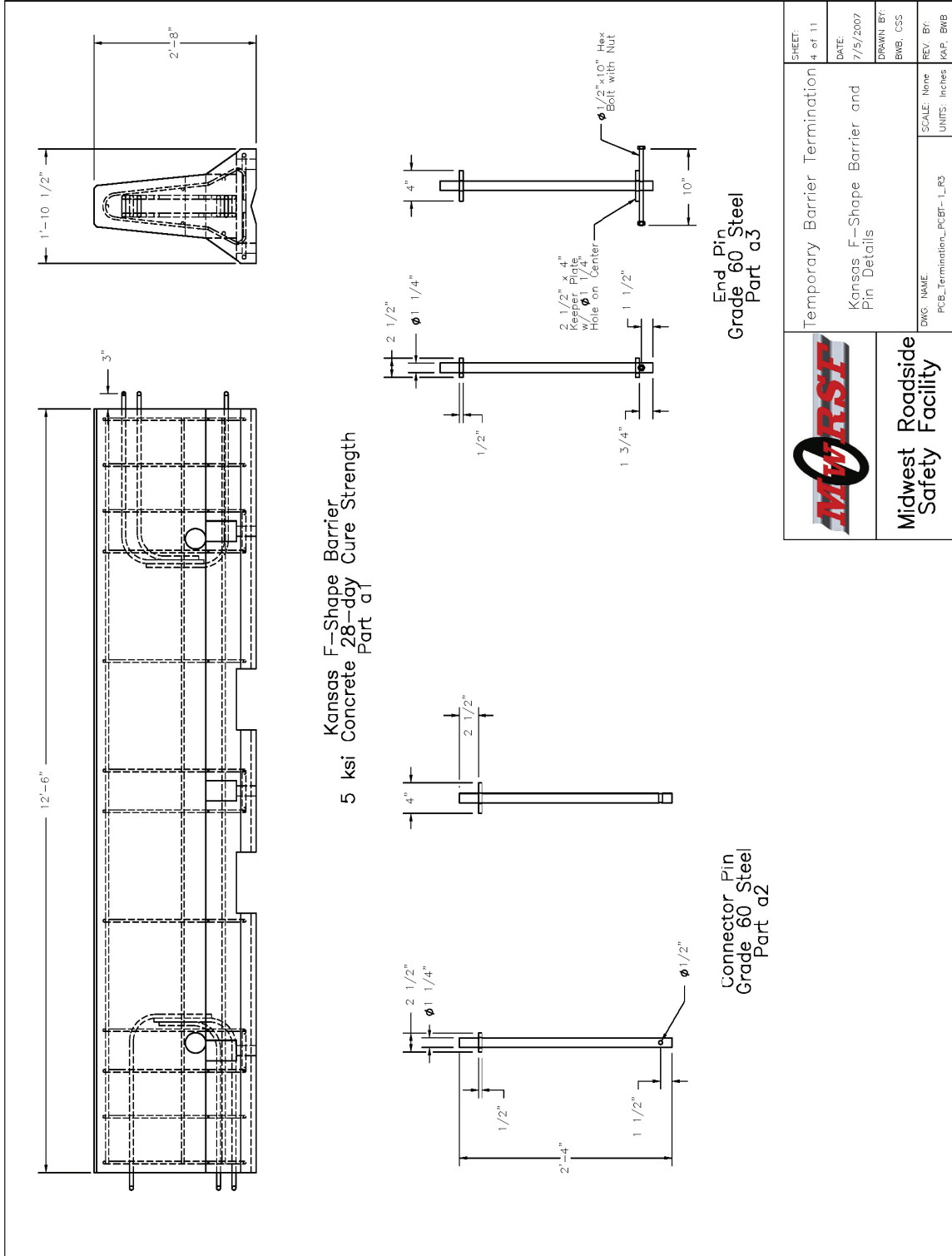

Figure 49. Termination of Temporary Concrete Barrier, Final Design Details

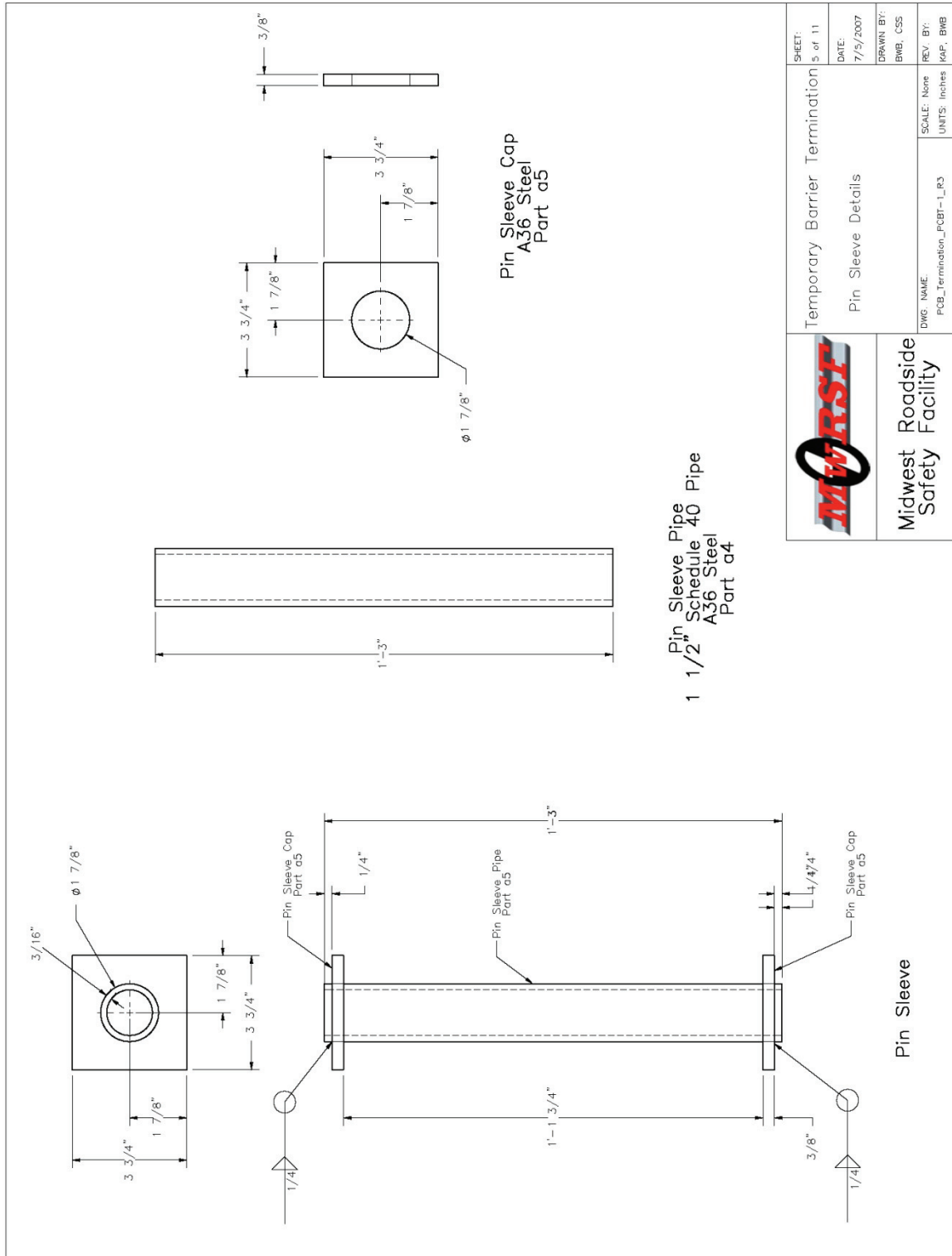

Figure 50. Termination of Temporary Concrete Barrier, Final Design Details

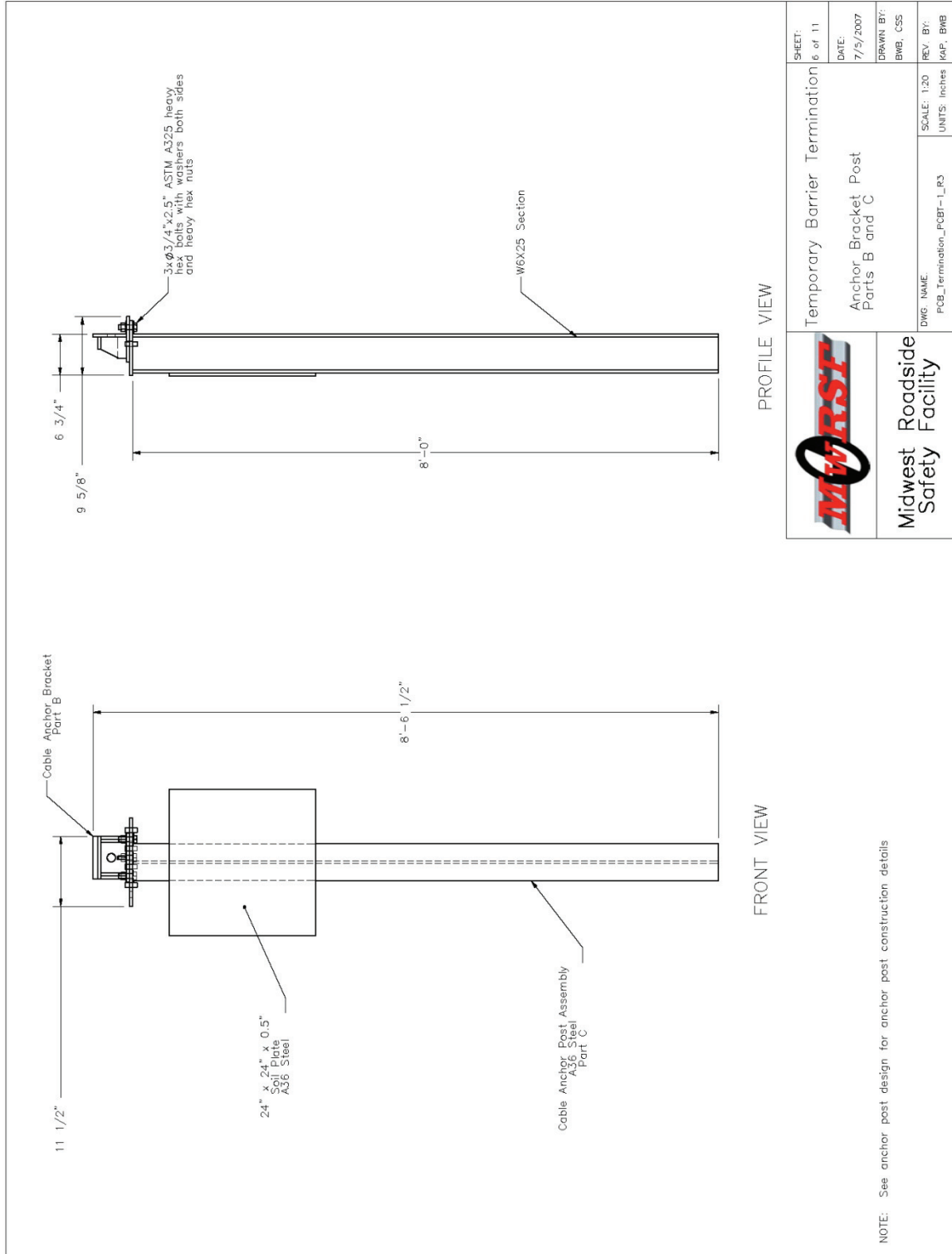

Figure 51. Termination of Temporary Concrete Barrier, Final Design Details

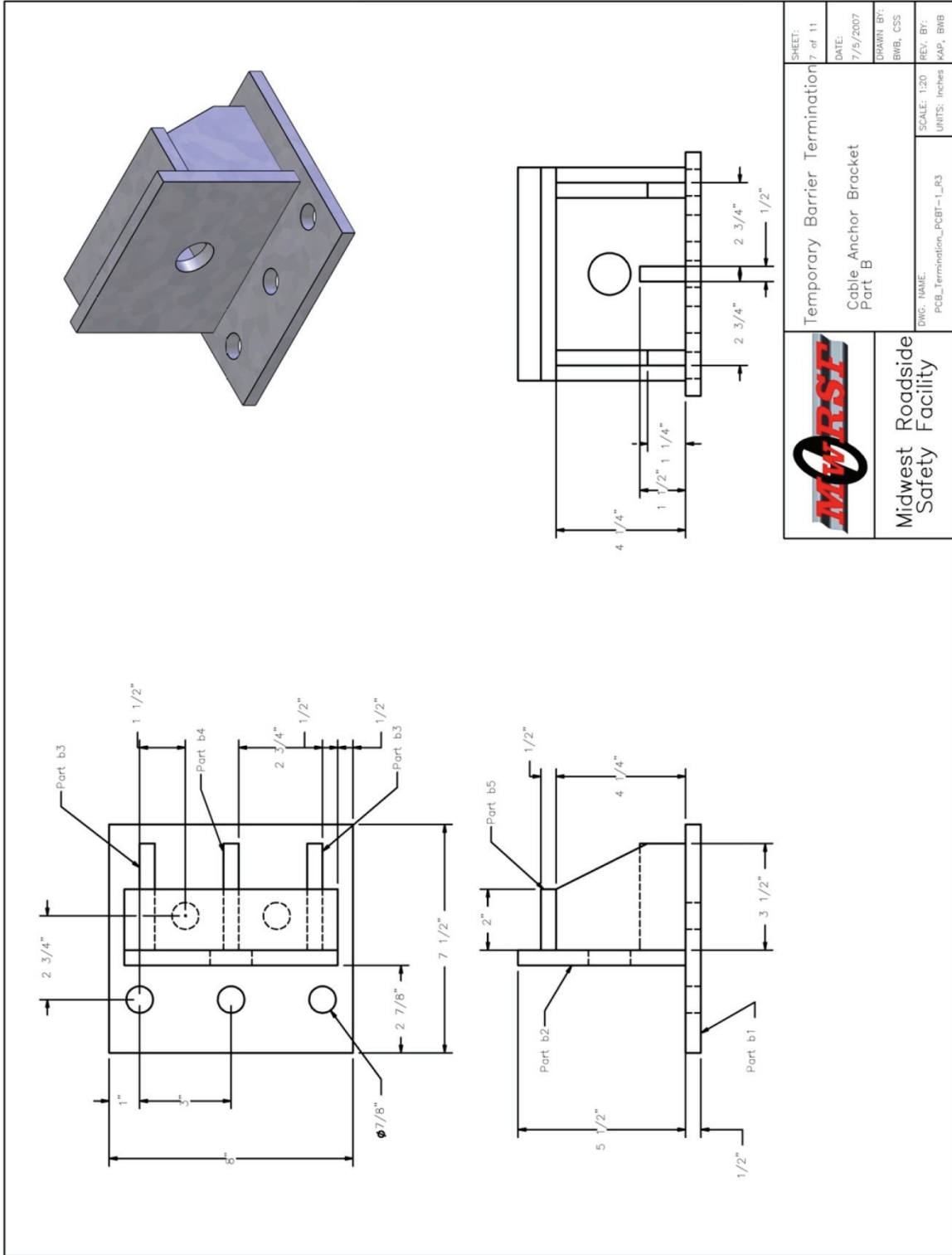

Figure 52. Termination of Temporary Concrete Barrier, Final Design Details

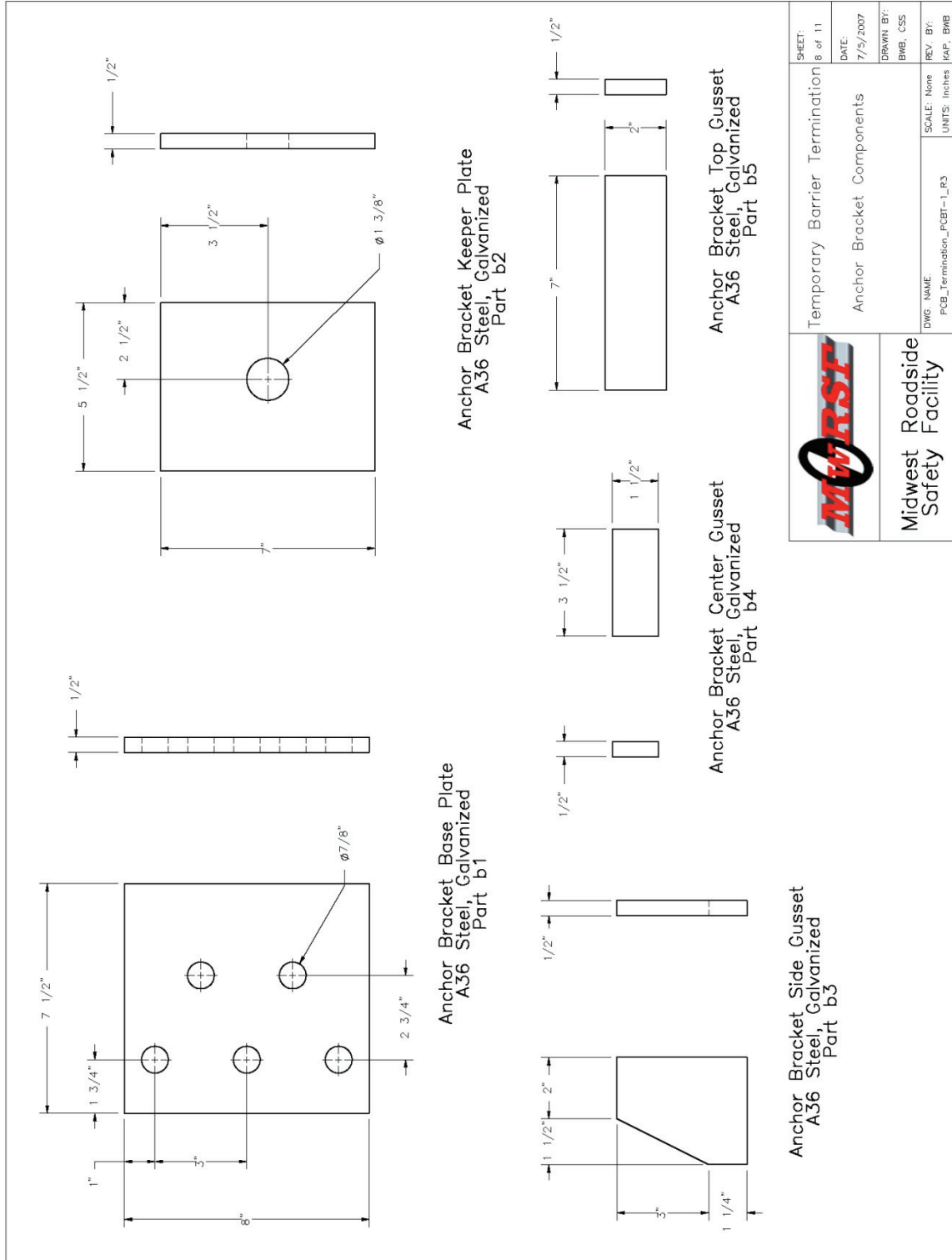

Figure 53. Termination of Temporary Concrete Barrier, Final Design Details

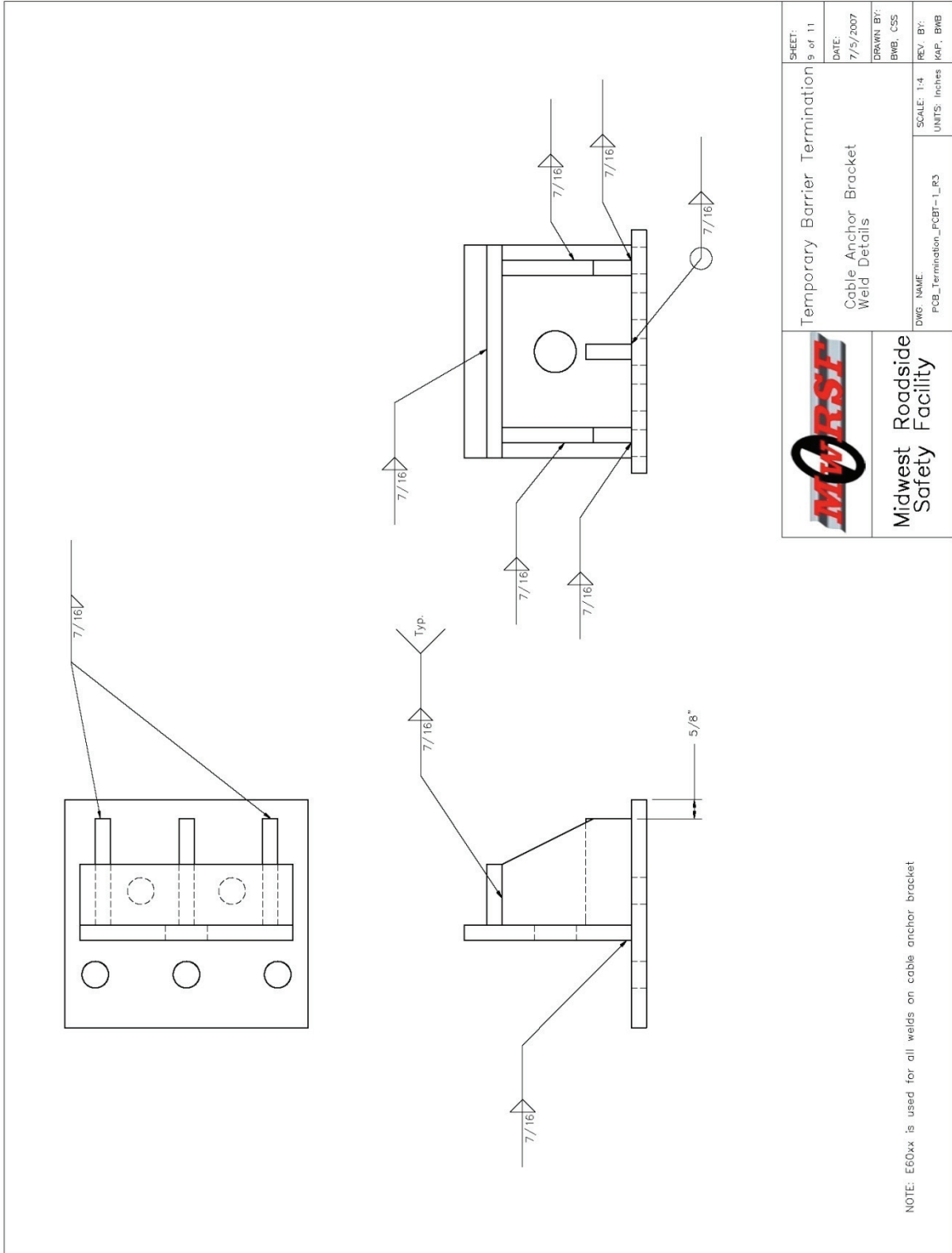

Figure 54. Termination of Temporary Concrete Barrier, Final Design Details

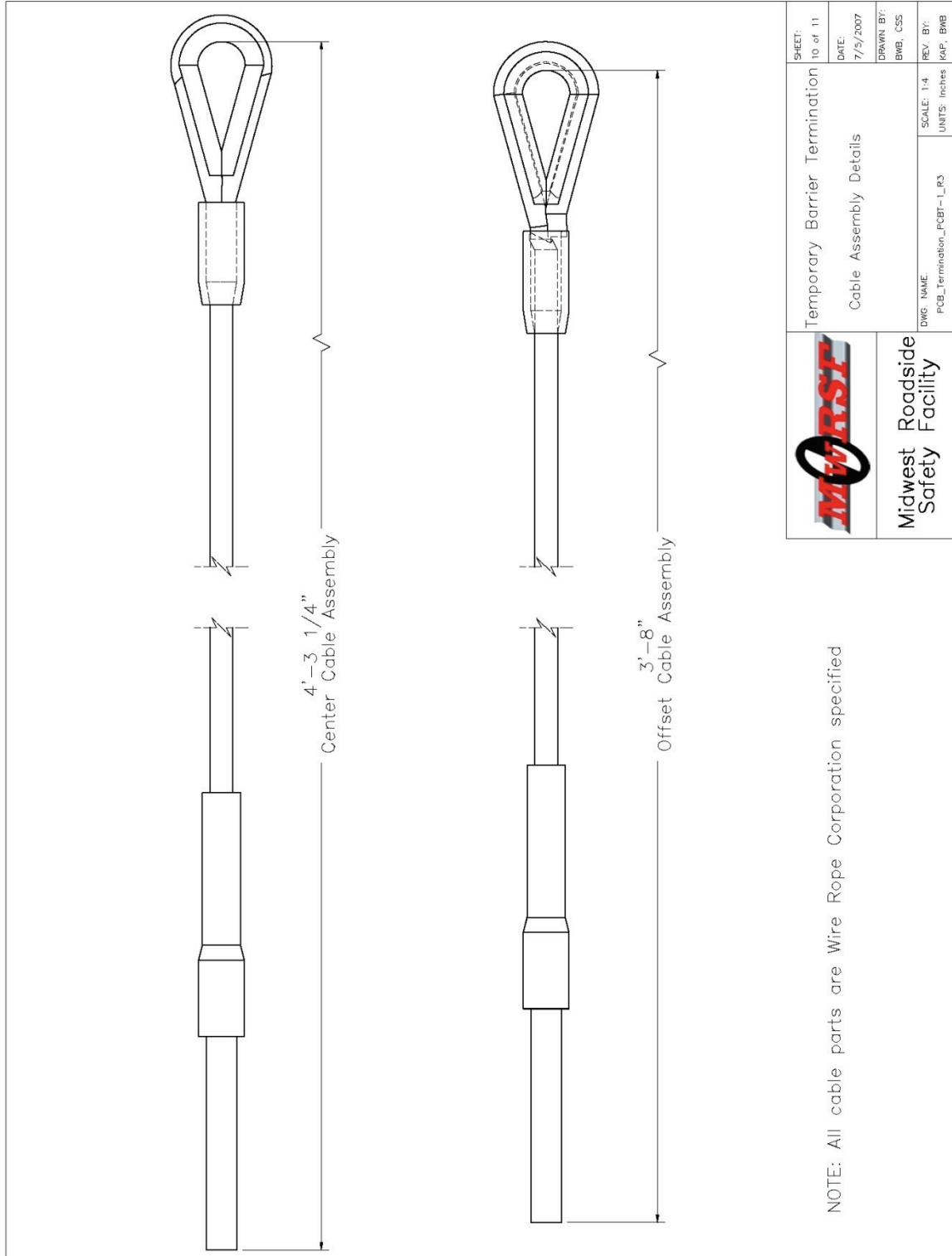

Figure 55. Termination of Temporary Concrete Barrier, Final Design Details

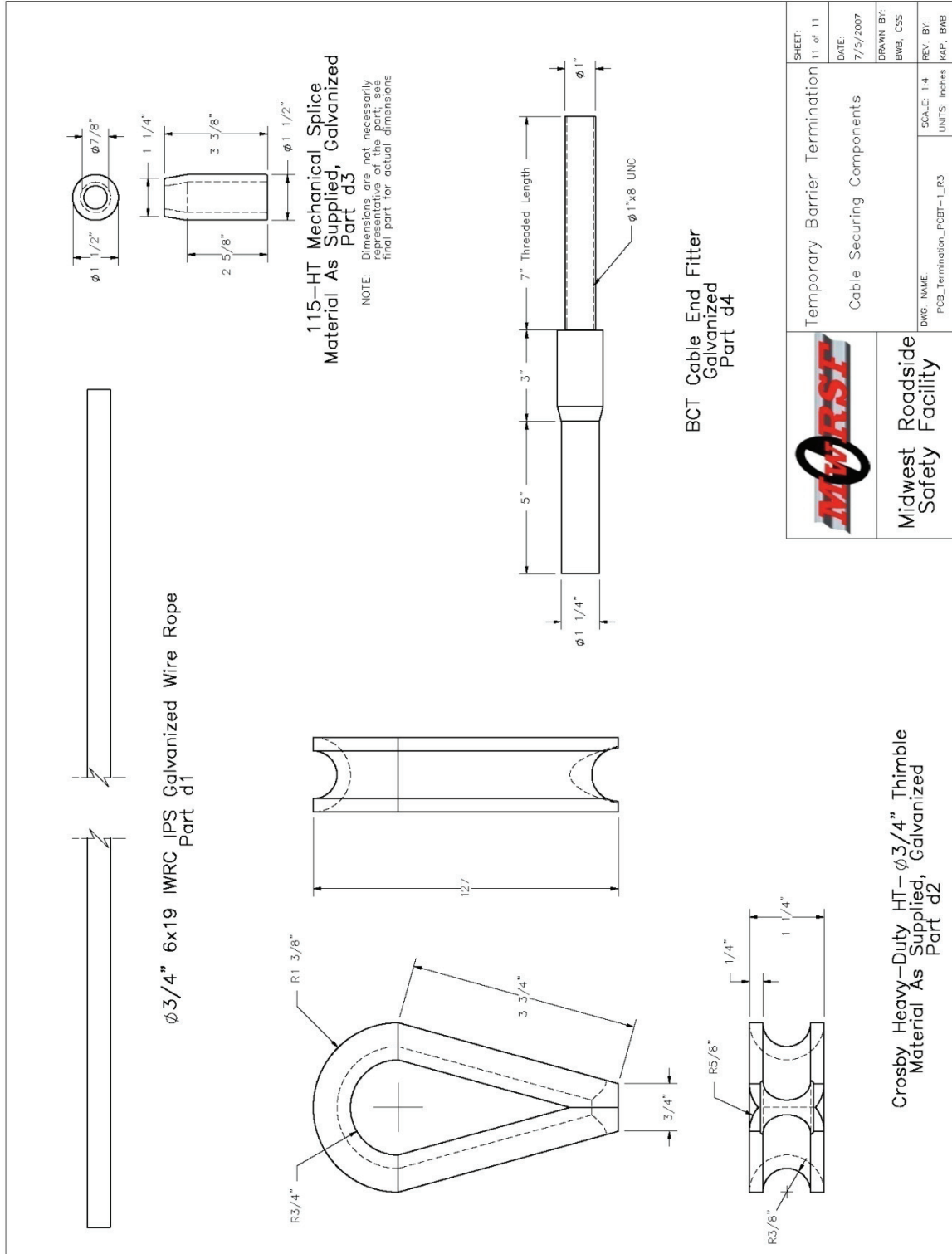

Figure 56. Termination of Temporary Concrete Barrier, Final Design Details

imparted through the cable assemblies. The maximum longitudinal overlap of end barrier on soil is 112.5 in. (2,858 mm), while the minimum lateral distance between the top plate of the anchor post and the pavement edge is 10.75 in. (273 mm). Larger lateral offsets are allowed. The minimum longitudinal length of the soil leave out for the anchor posts is a length defined by the upstream end of the first barrier segment and 12 in. (305 mm) upstream of the in-line anchor post. This layout is shown in Figure 47.

The termination and anchorage system described herein was designed for use with the Kansas F-shape temporary concrete barrier system. Therefore, it should not be used with other temporary concrete barrier systems or joint designs without further study. Although it is very likely that this termination and anchorage system can be adapted to other approved temporary concrete barrier systems, it is first necessary to consider several factors. They are as follows:

1. The structural capacity and geometry of the connection on the upstream end of the barrier must be considered. The current design used a constrained drop pin which passed through three steel loop bars. The termination and anchorage system connected to the steel drop pin at fixed vertical positions. In order to adapt this termination and anchorage system to other barriers, designers must ensure that the alternative connection on the end of the barrier has similar or greater strength to the crash tested design and will maintain similar vertical positioning of the anchor constraints to help reduce barrier rotations.
2. Alternative barrier segment lengths are acceptable if greater than 12.5 ft (3.81 m). With shorter barrier lengths, it is believed that additional barrier rotation will occur due to the greater number of joints, thus resulting in the propensity for increased vehicle climb and rollover.
3. Alternative barrier segments should have comparable mass per unit length.

4. Alternative barrier segments should have equal or greater steel reinforcement than the F-shape barrier described herein. This reinforcement recommendation includes the longitudinal steel bars, vertical shear stirrups, and containment steel bars surrounding the anchor boxes used with the vertical, tie-down anchor rods. Barriers with reinforcement levels below that of the tested design would not be acceptable unless demonstrated with full-scale crash testing.
5. The shape of alternative barrier segments may require further study. Past research has shown that the F-shape provides slightly improved results over those observed using the New Jersey shape barrier. Therefore, further study may be needed to assure safe performance when applying the termination and anchorage system to other barrier shapes.

As mentioned previously, the termination and anchorage system was designed such that the upstream barrier end would be shielded with either inertial sand barrel crash cushions or be placed outside the clear zone by flaring the end segments of the temporary barrier system. When using sand barrel crash cushions, the anchors posts are positioned to allow for the sand barrels to be placed adjacent to the anchors with only minor deviation from the standard sand barrel array, as shown in Figure 58. It should be noted that no variation of anchor spacing allowed for a perfect placement of the sand barrels at the end of the temporary barriers. For sand barrel arrays oriented parallel to the roadway and barrier system, the chosen anchor layout allowed for the sand barrels to be placed with only a 13.625-in. (346-mm) shift of one barrel on the traffic side of the array. For sand barrel arrays rotated to the 10 degree maximum recommended angle with respect to the roadway, the maximum deviation of the end barrel on the traffic side of the array was only 8.75 in. (222 mm). These minor variations in the placement of a single barrel are not

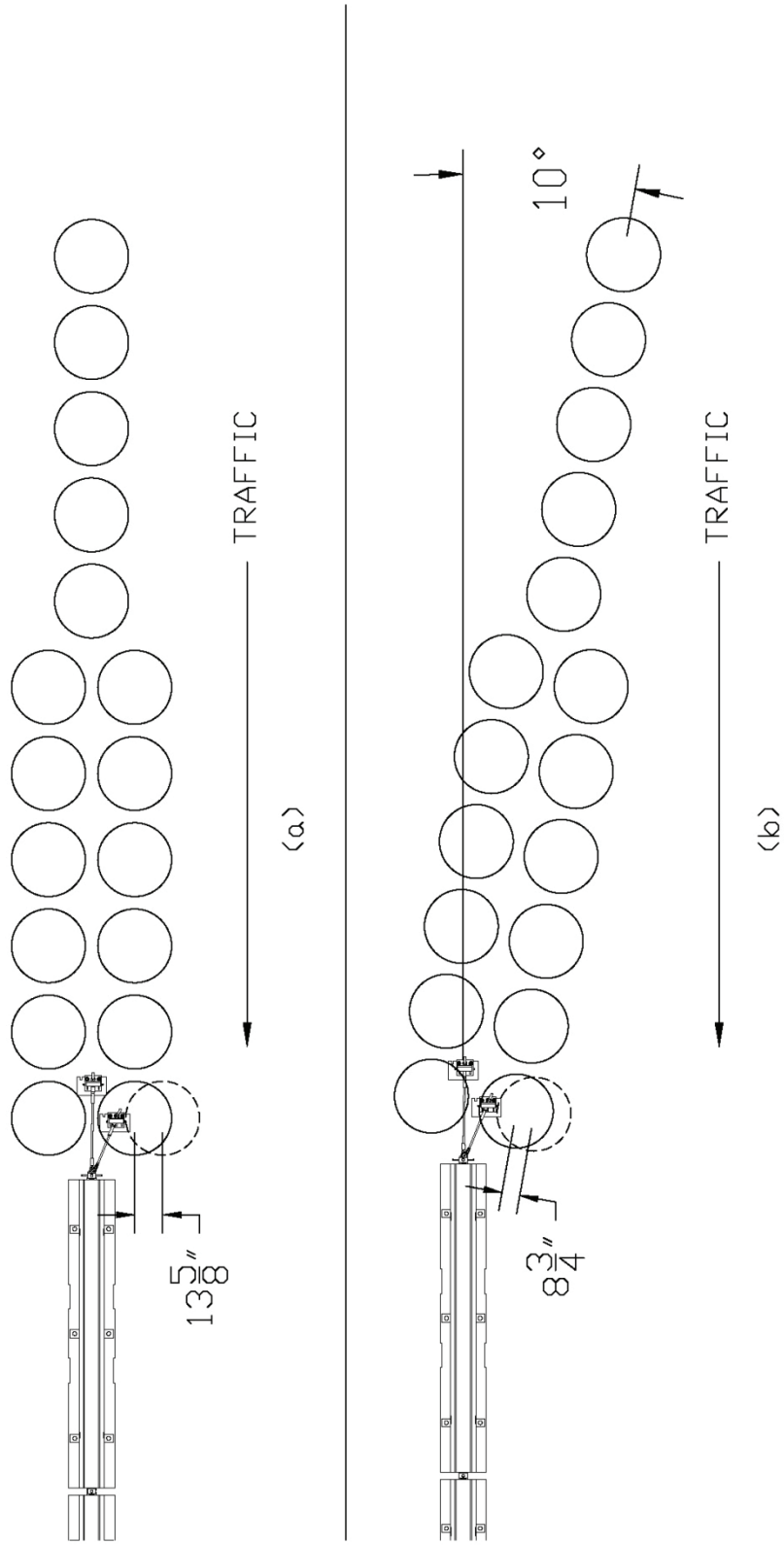

Figure 58. Schematic of Sand Barrel Array for Termination and Anchorage System

expected to adversely affect the safety performance of the sand barrel crash cushion. When the termination and anchorage system is installed on temporary barriers that have been flared to place the end barriers outside of the clear zone, appropriate flare rates guidelines should be used, such as those found in the AASHTO Roadside Design Guide [17].

For reverse direction impacts on the termination and anchorage system, some additional comments are required. If the upstream end of the temporary barrier system is flared outside of the clear zone, then reverse-direction impacts do not need to be addressed. However, installations where the termination and anchorage system is installed inside the clear zone require further discussion. Currently, sand barrel arrays do not address reverse-direction impacts. For reverse-direction crashes into sand barrel arrays, vehicle impacts could occur into massive barrels at the end of the array, thus leading to very sudden decelerations and changes in velocity as well as increased occupant risk. Previously, MwRSF provided guidance to the Midwest States' Pooled Fund Program regarding sand barrel arrays subjected to reverse-direction impacts. These modified designs are shown in Figure 59 and Figure 60. It is recommended that reverse direction sand barrel arrays be used when treating temporary concrete barriers with termination and anchorage systems subjected to both standard and reverse-direction impacts.

It may be possible to use other proprietary crash cushions to treat the upstream end of free-standing temporary concrete barriers which incorporate the termination and anchorage system detailed herein. Most of these crash cushion technologies utilize a foundation for anchoring and supporting the crash cushion. As such, it may be possible to use this foundation to support the new termination and anchorage system. However, additional research, development, and testing would be needed to verify that the termination and anchorage system would

$$V = 100 \text{ km/h}$$

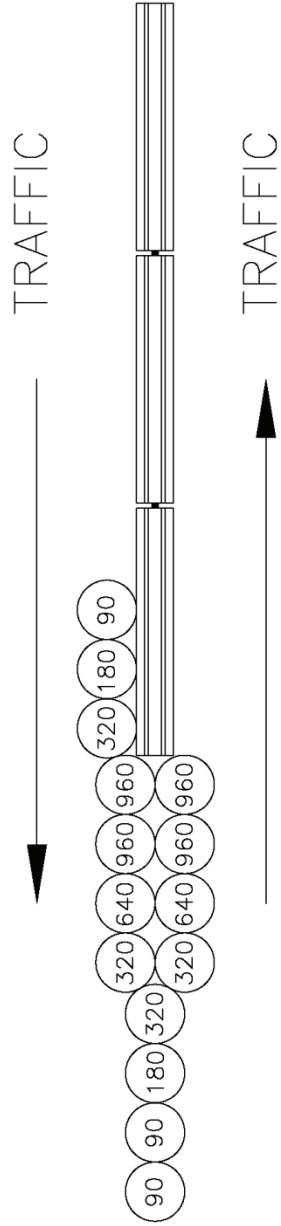

(a)

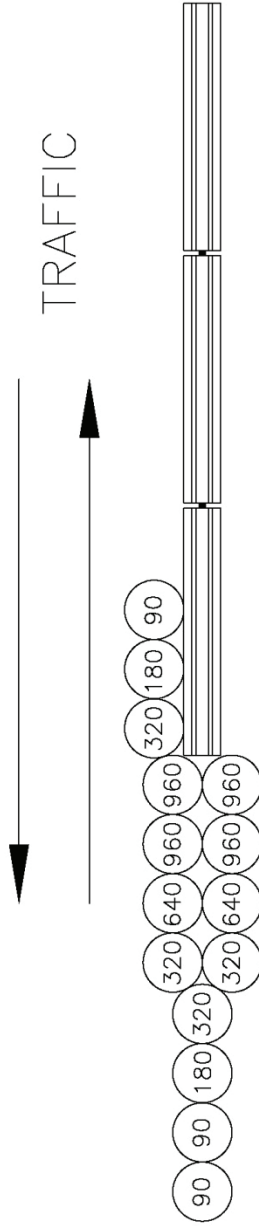

(b)

<u>Metric → SI Unit Conversions</u>	
1 kg	= 2.2046 lbs
1 km/h	= .6214 mph

Figure 59. Reverse Direction Impact Sand Barrel Array, 100 km/h (metric units)

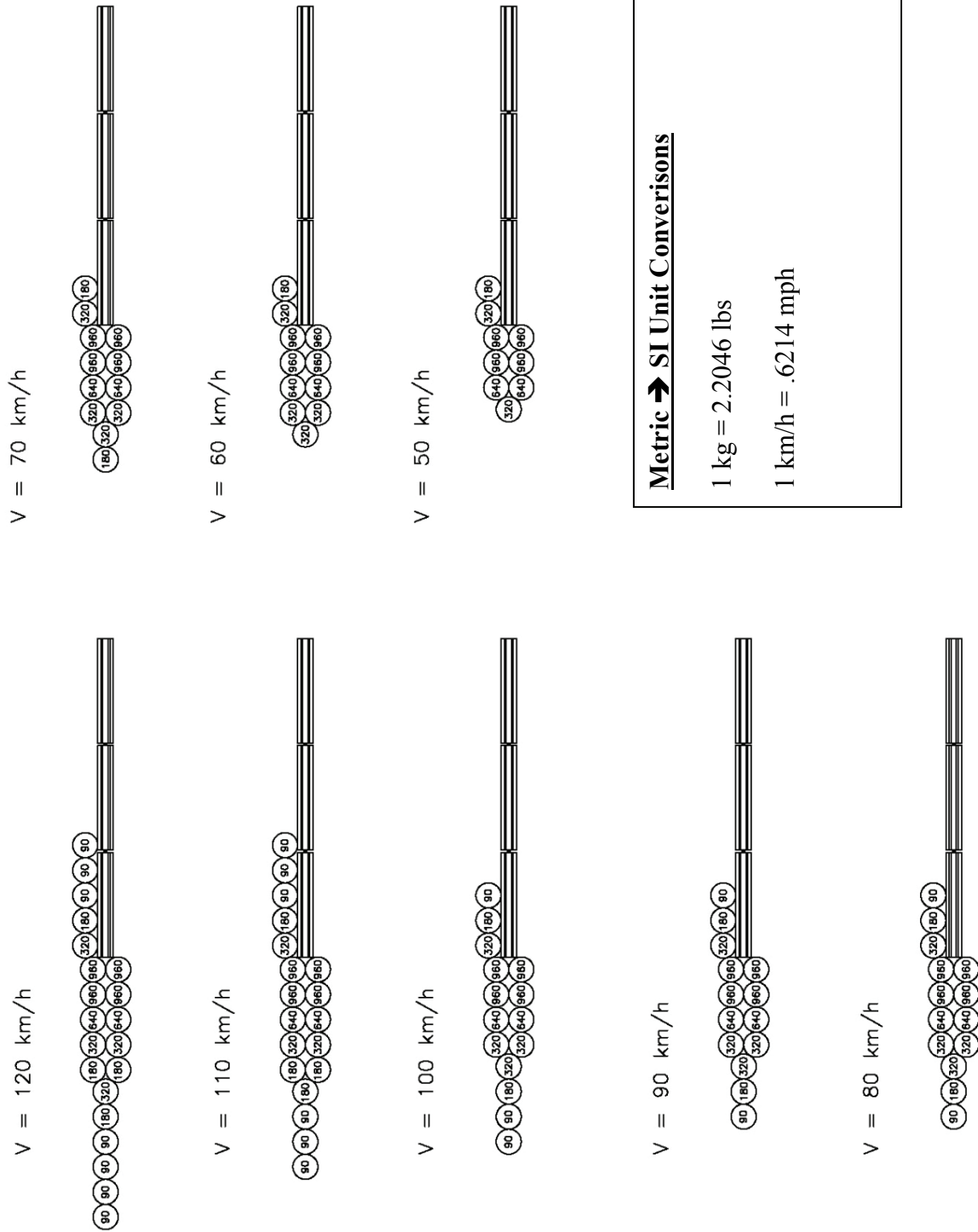

Figure 60. Reverse Impact Sand Barrel Array, Various Speeds (metric units)

perform as intended. While it was outside of the scope of this research study to adapt the new system to the wide variety of proprietary crash cushion technologies, the researchers believe that these details could be developed.

Finally, it should be noted that the termination and anchorage system described herein was developed as an upstream anchorage for temporary concrete barriers used in roadside applications. The anchorage was not designed for use as a downstream anchorage nor as an anchorage for use in temporary concrete barrier installations involving traffic on both sides of the barrier, such as in median or gore areas. The termination and anchorage system is not recommended for use on the downstream end of a temporary concrete barrier installation because the effects of vehicle interaction with the cable assemblies during impacts near the end of the barrier system are largely unknown. Unlike guardrail terminals, the anchor cables in this design do not include a mechanism for release during impacts near the downstream end of the system. As such, it is not known what type of behavior and interaction would result between the vehicle and the barrier during an impact with the end of the barrier system when a downstream anchorage was installed. Similarly, the end termination should not be installed in applications where temporary concrete barrier has traffic on both sides of the barrier. The use of the offset cable anchor to provide resistance to vertical barrier rotation makes the anchorage design directional by nature. As such, impacts on the side of the barrier without the offset anchor near the end of the temporary concrete barrier installation will result in different anchorage performance than observed in the test described herein. In this type of impact, the offset anchor cable would not develop tension or load until a significant amount barrier translation was observed, thus rendering that cable anchorage largely ineffective.

10 REFERENCES

1. Polivka, K.A., Faller, R.K., Sicking, D.L., Rohde, J.R., Bielenberg, R.W., Reid, J.D., and Coon, B.A., *Performance Evaluation of the Free-Standing Temporary Barrier – Update to NCHRP 350 Test No. 3-11 (2214TB-1)*, submitted to the National Cooperative Highway Research Program, Transportation Research Report TRP-03-173-06, Midwest Roadside Safety Facility, University of Nebraska- Lincoln, October 2006.
2. Sicking, D.L., Mak, K.K., Rohde, J.R., and Reid, J.D., *Manual for Assessing Safety Hardware - Draft Report*, Submitted to the National Cooperative Highway Research Program (NCHRP), Project 22-14(2) Panel, Prepared by the Midwest Roadside Safety Facility, University of Nebraska-Lincoln, Lincoln, Nebraska, 2008.
3. Polivka, K.A., Faller, R.K., Rohde, J.R., Holloway, J.C., Bielenberg, B.W., and Sicking, D.L., *Development and Evaluation of a Tie-Down System for the Redesigned F-Shape Concrete Temporary Barrier*, Final Report to the Midwest State's Regional Pooled Fund Program, Transportation Research Report No. TRP-03-134-03, Project No. SPR-3(017)-Year 13, Project Code: RPPF-03-06, Midwest Roadside Safety Facility, University of Nebraska-Lincoln, August 22, 2003.
4. Faller, R.K., Rohde, J.R., Rossen, B.T., Smith, R.P., and Addink, K.H., *Development of a TL-3 F-Shape Temporary Concrete Median Barrier*, Transportation Research Report No. TRP-03-64-96, Midwest Roadside Safety Facility, University of Nebraska- Lincoln, December 1996.
5. Ross, H.E., Sicking, D.L., Zimmer, R.A., and Michie, J.D., *Recommended Procedures for the Safety Performance Evaluation of Highway Features*, National Cooperative Highway Research Program (NCHRP) Report No. 350, Transportation Research Board, Washington, D.C., 1993.
6. Polivka, K.A., Faller, R.K., Sicking, D.L., Rohde, J.R., Bielenberg, R.W., Reid, J.D., and Coon, B.A., *Performance Evaluation of the Free-Standing Temporary Barrier – Update to NCHRP 350 Test No. 3-11 with 28" C.G. Height (2214TB-2)*, submitted to the National Cooperative Highway Research Program, Transportation Research Report TRP-03-174-06, Midwest Roadside Safety Facility, University of Nebraska- Lincoln, October 2006.
7. Bielenberg, B.W., Faller, R.K., Rohde, J.R., Ried, J.D., Sicking, D.L., and Holloway, J.C., *Development of Tie-Down and Transition Systems for Temporary Concrete Barrier on Asphalt Road Surfaces*, Final Report to the Midwest State's Regional Pooled Regional Pooled Fund Program, Transportation Research Report No. TRP-03-180-06, Midwest Roadside Safety Facility, University of Nebraska Lincoln, February 23, 2007.

8. Bielenberg, R.W., Faller, R.K., Sicking, D.L., Rohde, J.R., and Reid, J.D., “Tie-Downs and Transitions for Temporary Concrete Barriers”, Paper No. 06-1276, Transportation Research Record No. 1984, Transportation Research Board, Washington, D.C., December 2006.
9. Wiebelhaus, M.J., Terpsma, R., Polivka, K.A., Faller, R.K., Sicking, D.L., Bielenberg, R.W., Reid, J.D., and Rohde, J.R., *Development of a Median Approach Transition from Temporary to Rigid Concrete Barrier*, Draft Report to the Midwest State’s Regional Pooled Regional Pooled Fund Program, Transportation Research Report No. TRP-03-208-09, Midwest Roadside Safety Facility, University of Nebraska Lincoln, Draft Report in Progress.
10. Hallquist, J. O., *LS-DYNA Keyword Users Manual: Version 940*, Livermore California, Livermore Software Technology Corporation, June 1997.
11. Polivka, K.A., Sicking, D.L., and Reid, J.D., *Deflections Limits for Temporary Concrete Barriers, Revised* Final Report to the Midwest State’s Regional Pooled Fund Program, Transportation Research Report No. TRP-03-113-02, Project No. SPR-3(017)-Year 9, Midwest Roadside Safety Facility, University of Nebraska-Lincoln, June 18, 2003.
12. Nelson, R.M., Sicking, D.L., Faller, R.K., Reid, J.D., Rohde, J.R., Polivka, K.A., and Hascall, J.A., *Evaluation of Alternate Cable Anchor Designs and Three-Cable Guardrail Adjacent to Steep Slope*, Final Report to the Midwest State’s Regional Pooled Fund Program, Transportation Research Report No. TRP 03-155-05, Project No. SPR-3(017)-Year 10, Project Code: RPPF-00-06, Midwest Roadside Safety Facility, University of Nebraska Lincoln, February 3, 2005.
13. Hinch, J., Yang, T.L., and Owings, R., *Guidance Systems for Vehicle Testing*, ENSCO, Inc., Springfield, VA, 1986.
14. *Center of Gravity Test Code - SAE J874 March 1981*, SAE Handbook Vol. 4, Society of Automotive Engineers, Inc., Warrendale, Pennsylvania, 1986.
15. *Vehicle Damage Scale for Traffic Investigators*, Second Edition, Technical Bulletin No. 1, Traffic Accident Data (TAD) Project, National Safety Council, Chicago, Illinois, 1971
16. *Collision Deformation Classification – Recommended Practice J224 March 1980*, Handbook Volume 4, Society of Automotive Engineers (SAE), Warrendale, Pennsylvania, 1985
17. *Roadside Design Guide*, American Association of State Highway and Transportation Officials (AASHTO), Washington, D.C. (2006).

11 APPENDICES

APPENDIX A. Metric-Unit Design Details

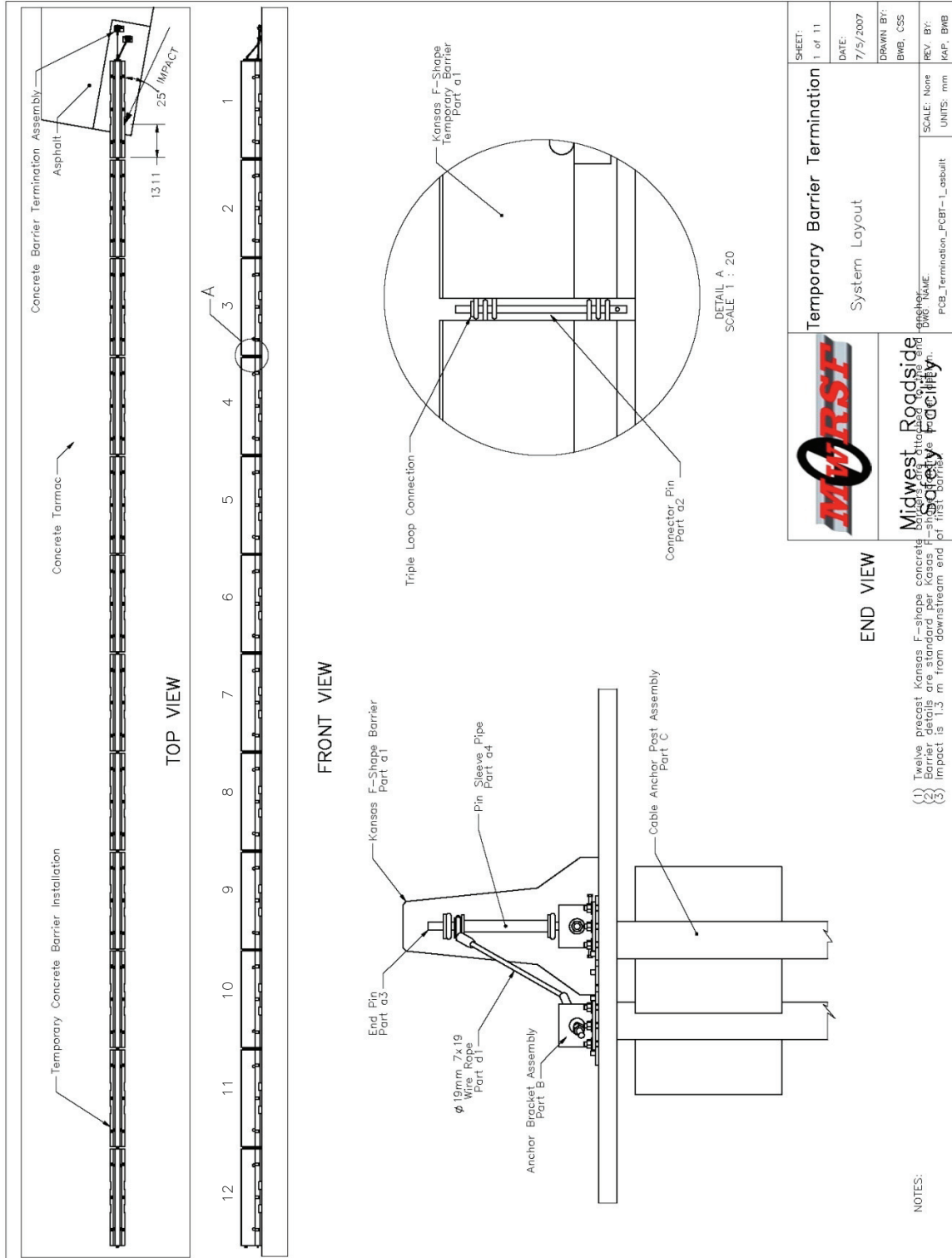

Figure A-1. Termination of Temporary Concrete Barrier, Test No. TTCB-1

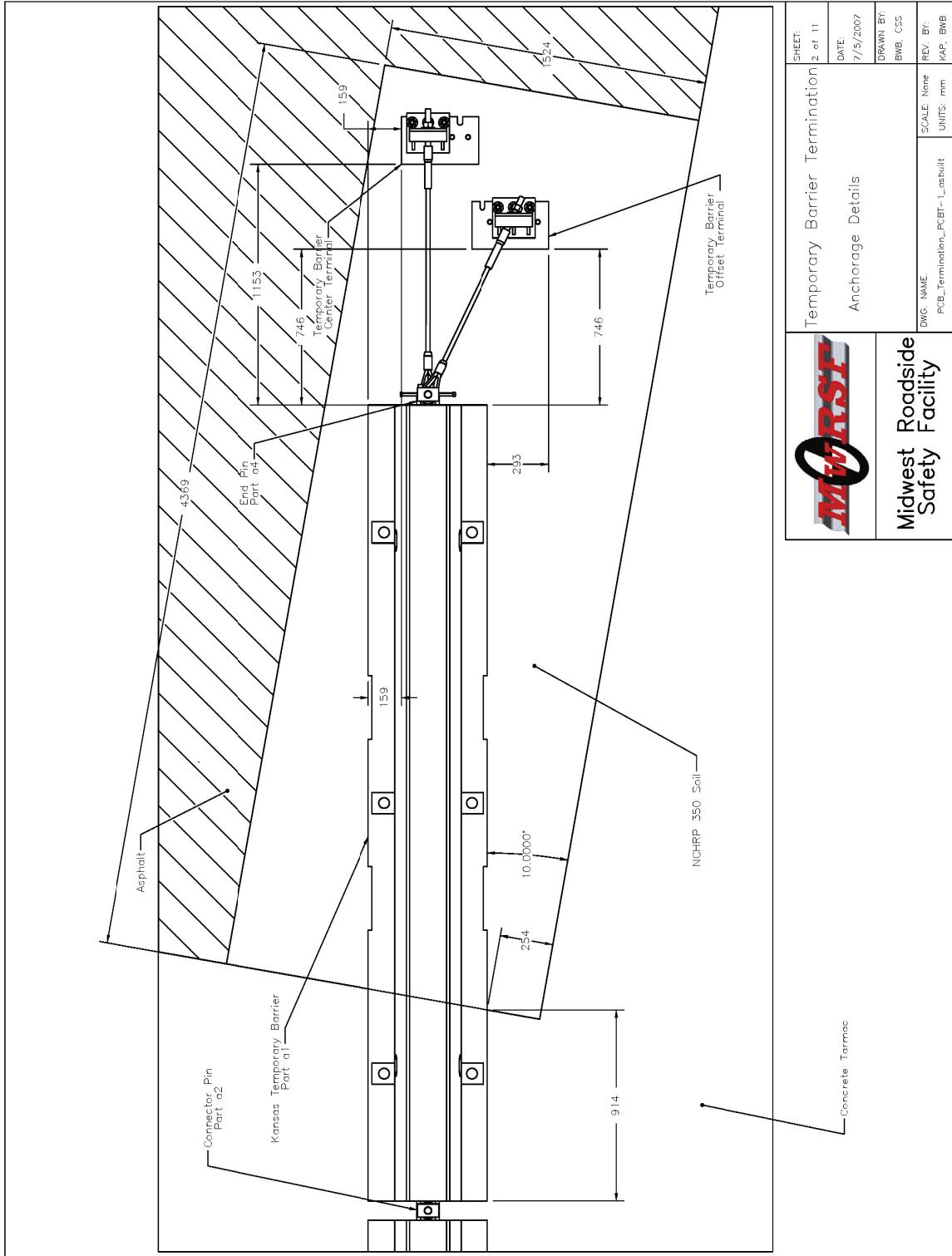

Figure A-2. Termination of Temporary Concrete Barrier, Test No. TTCB-1

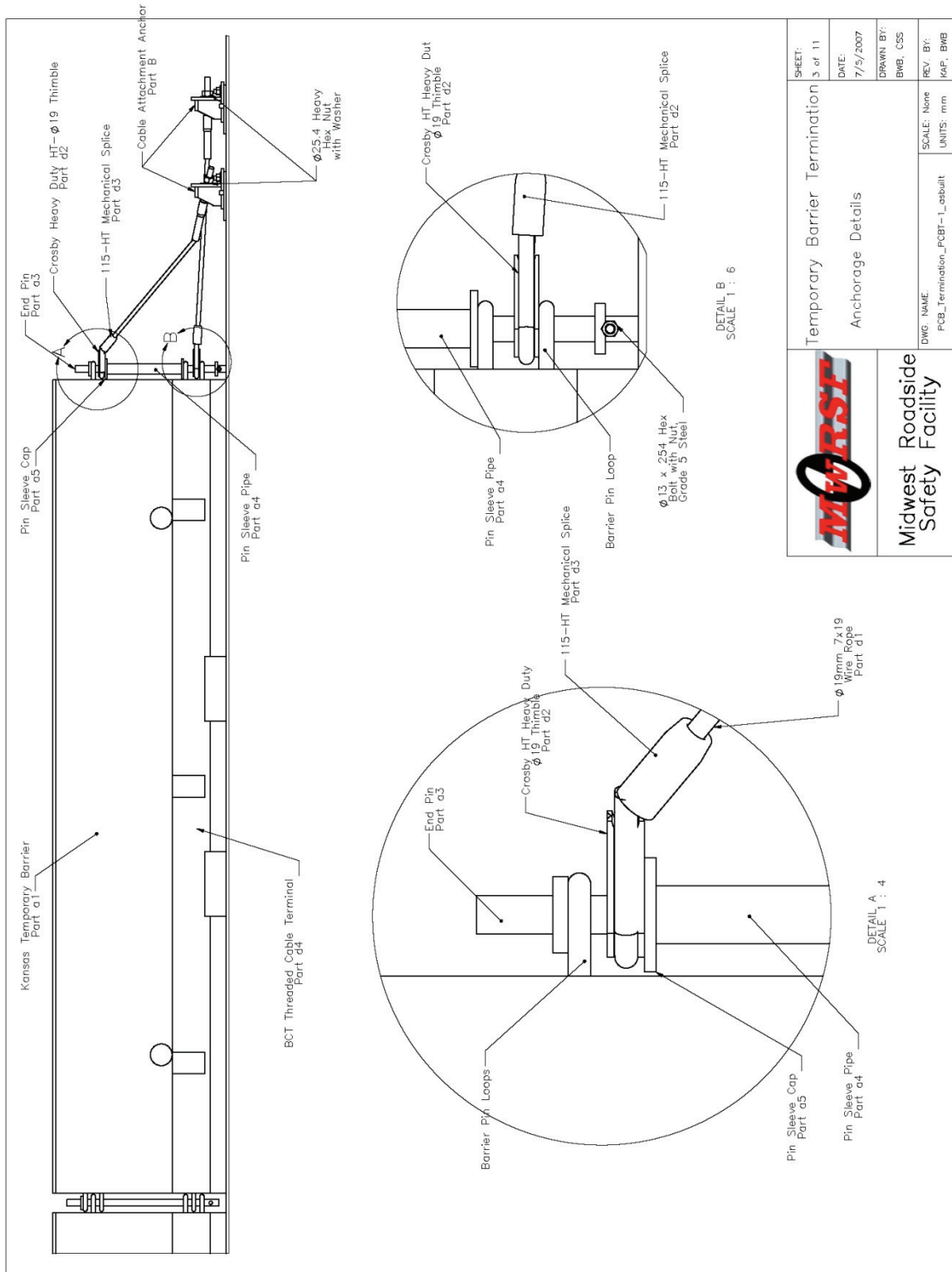

Figure A-3. Termination of Temporary Concrete Barrier, Test No. TTCB-1

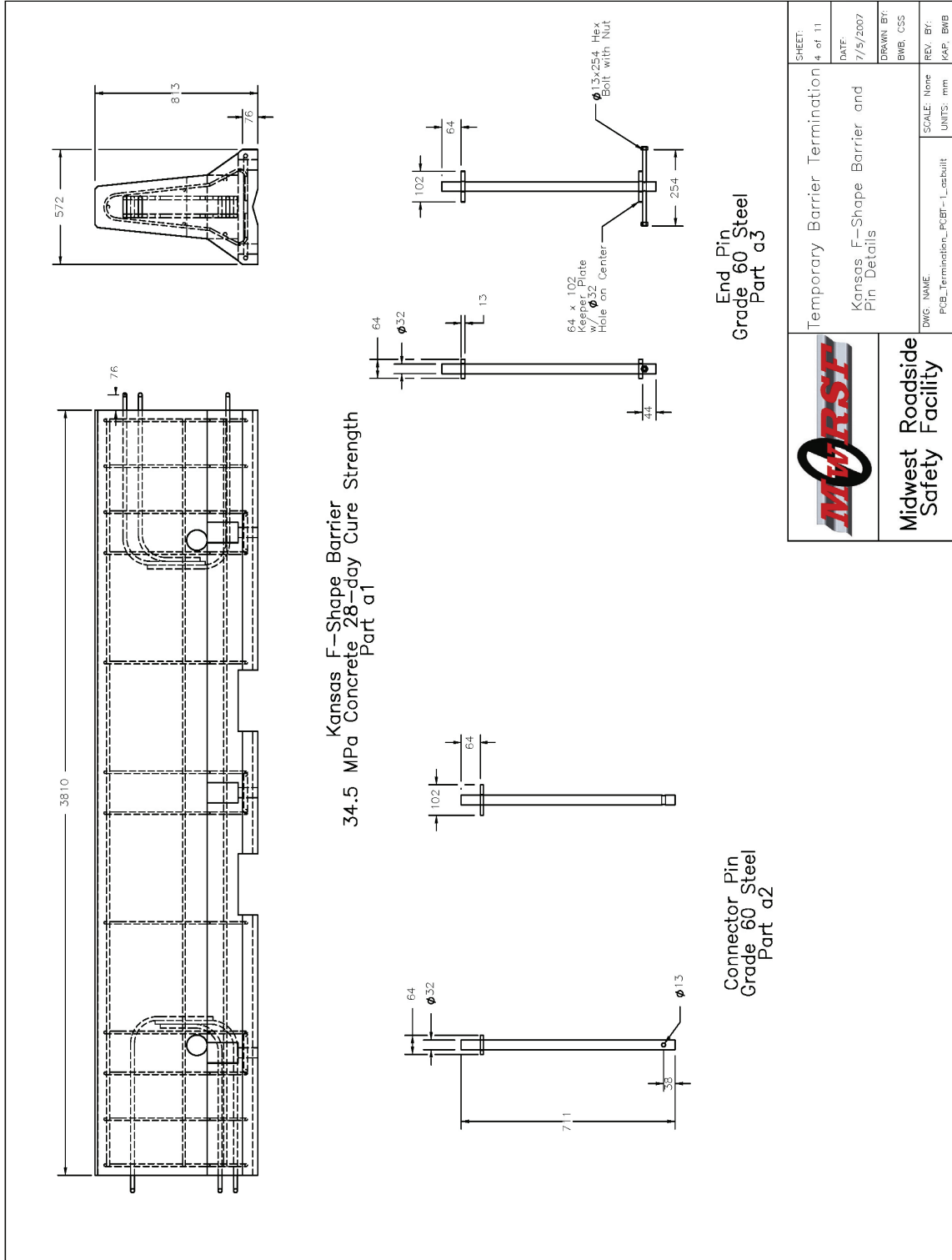

Figure A-4. Termination of Temporary Concrete Barrier, Test No. TTCB-1

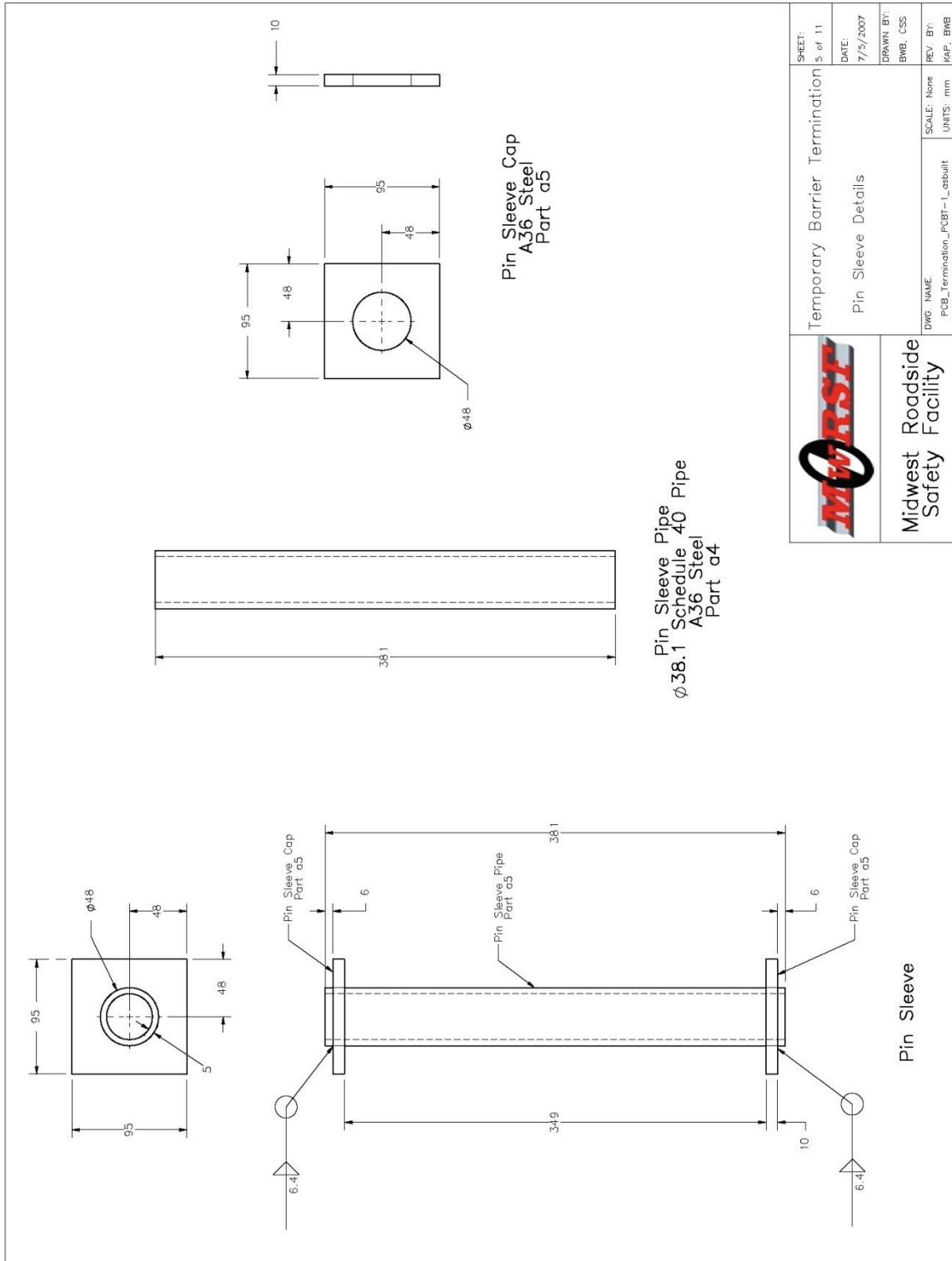

Figure A-5. Termination of Temporary Concrete Barrier, Test No. TTCB-1

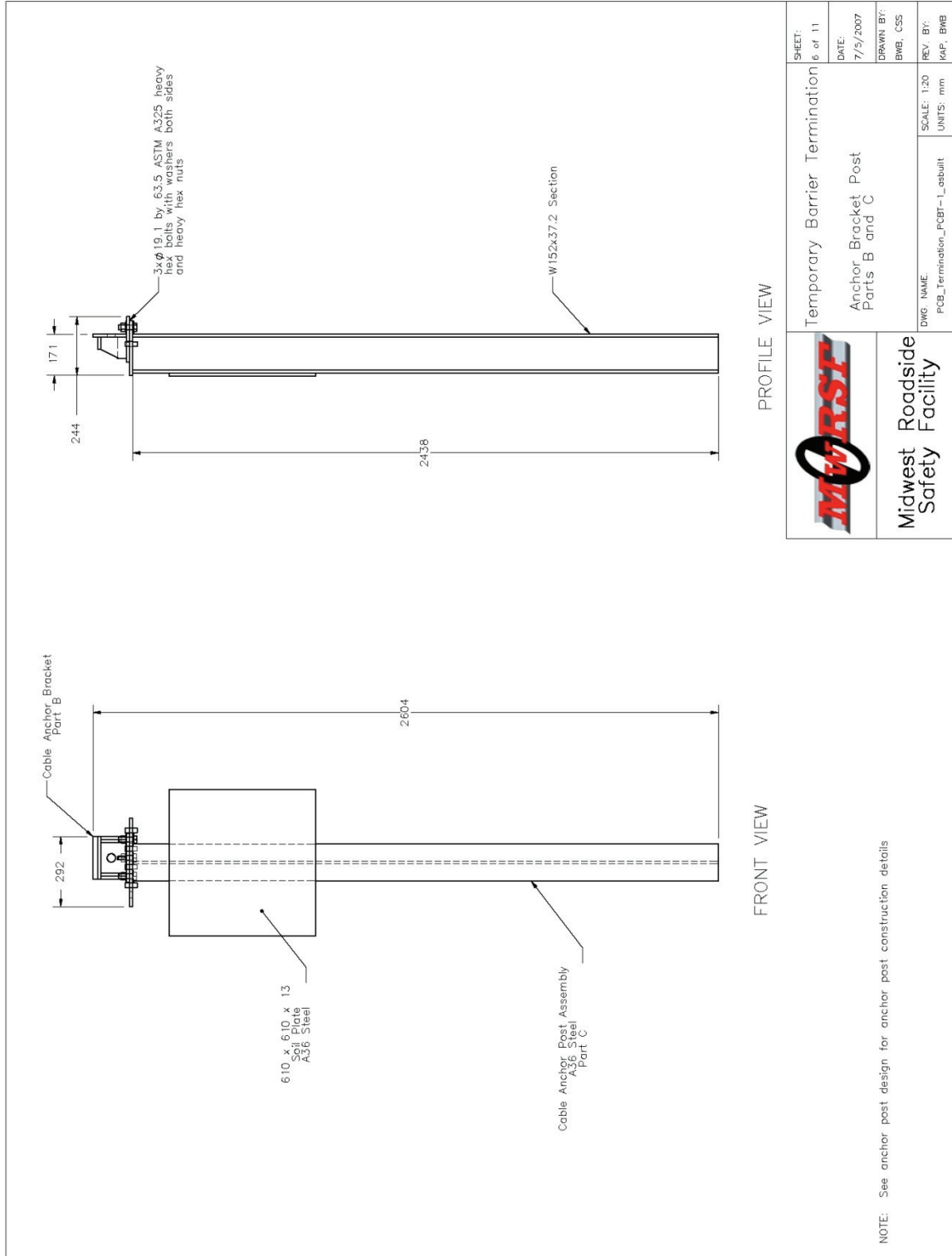

Figure A-6. Termination of Temporary Concrete Barrier, Test No. TTCB-1

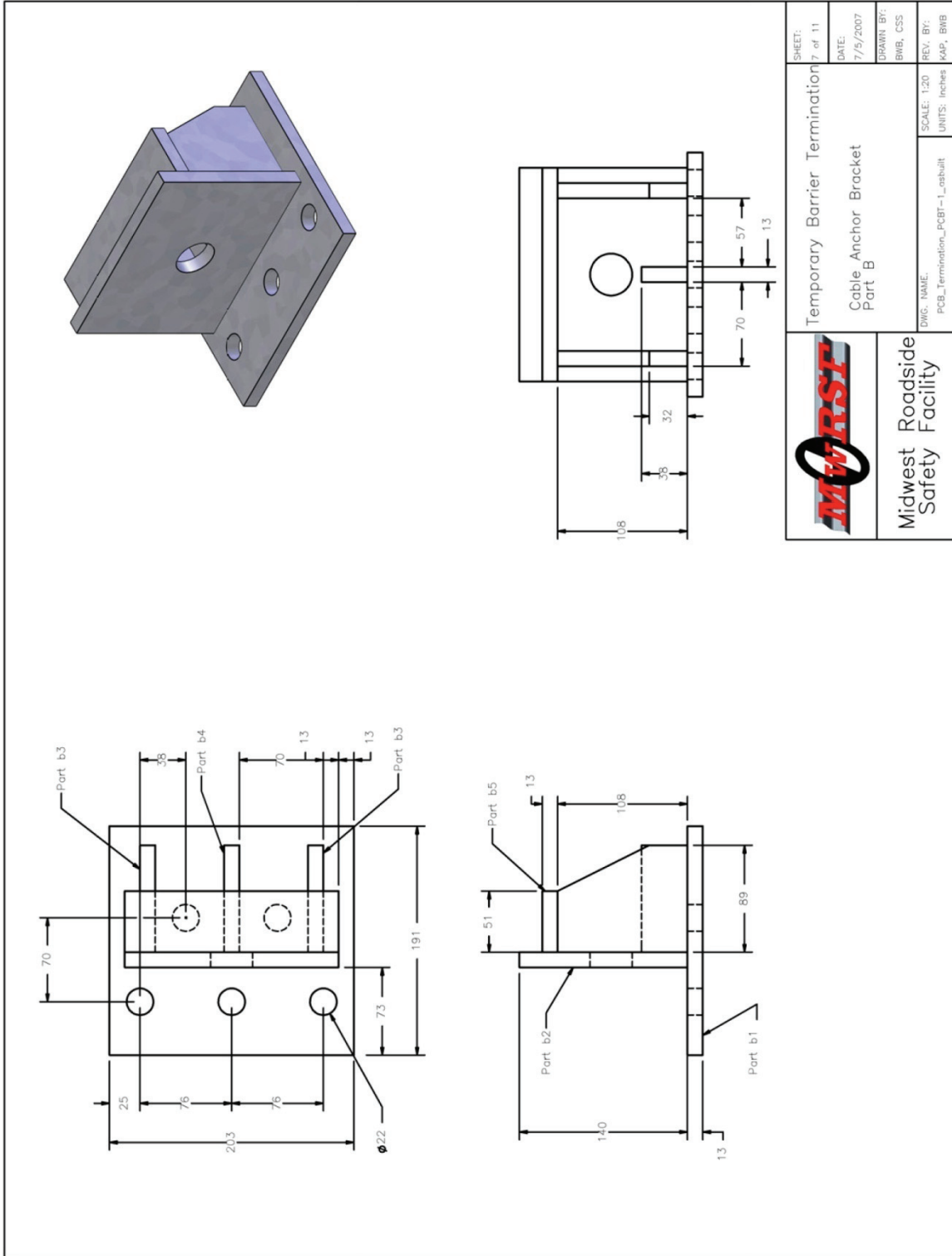

Figure A-7. Termination of Temporary Concrete Barrier, Test No. TTCB-1

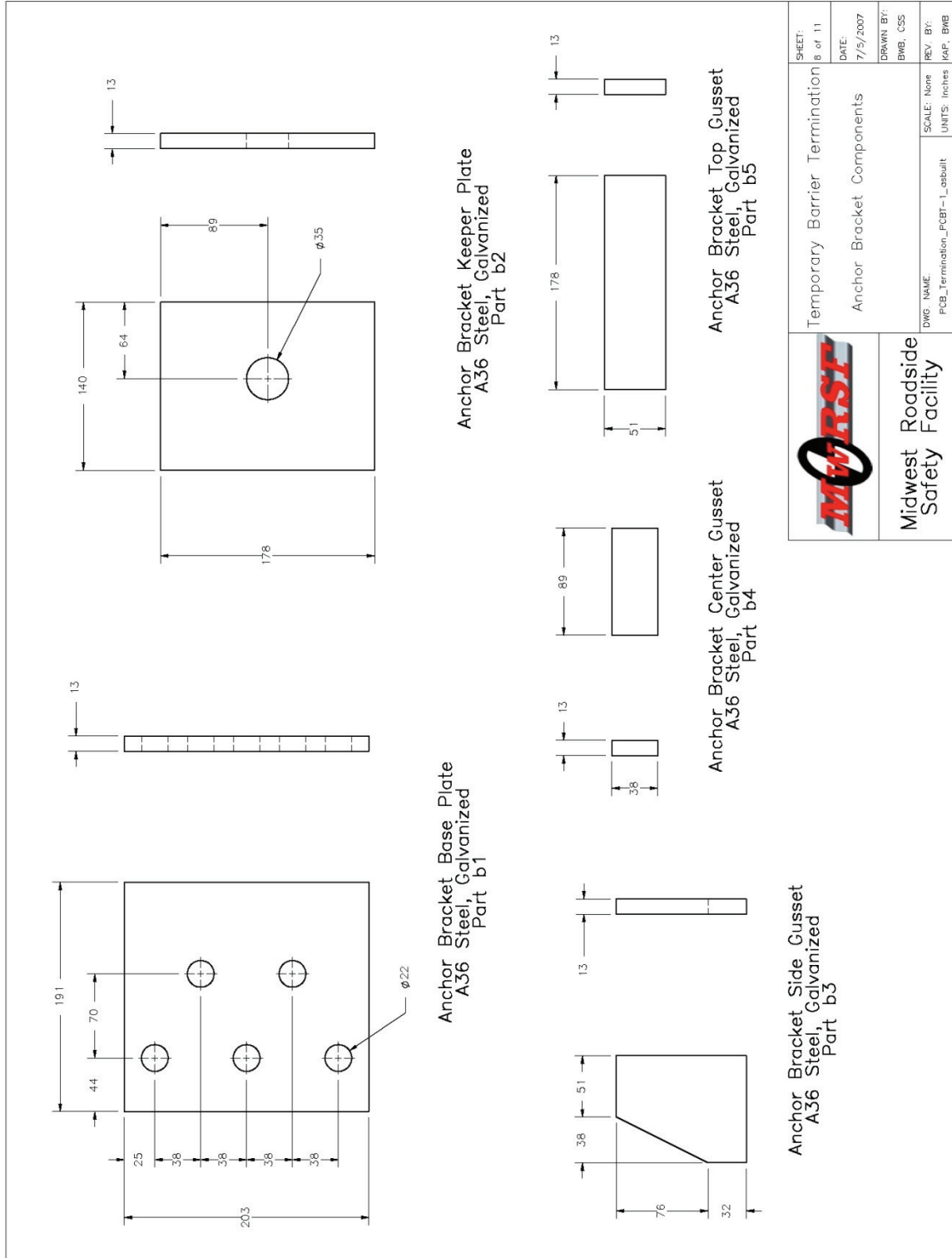

Figure A-8. Termination of Temporary Concrete Barrier, Test No. TTCB-1

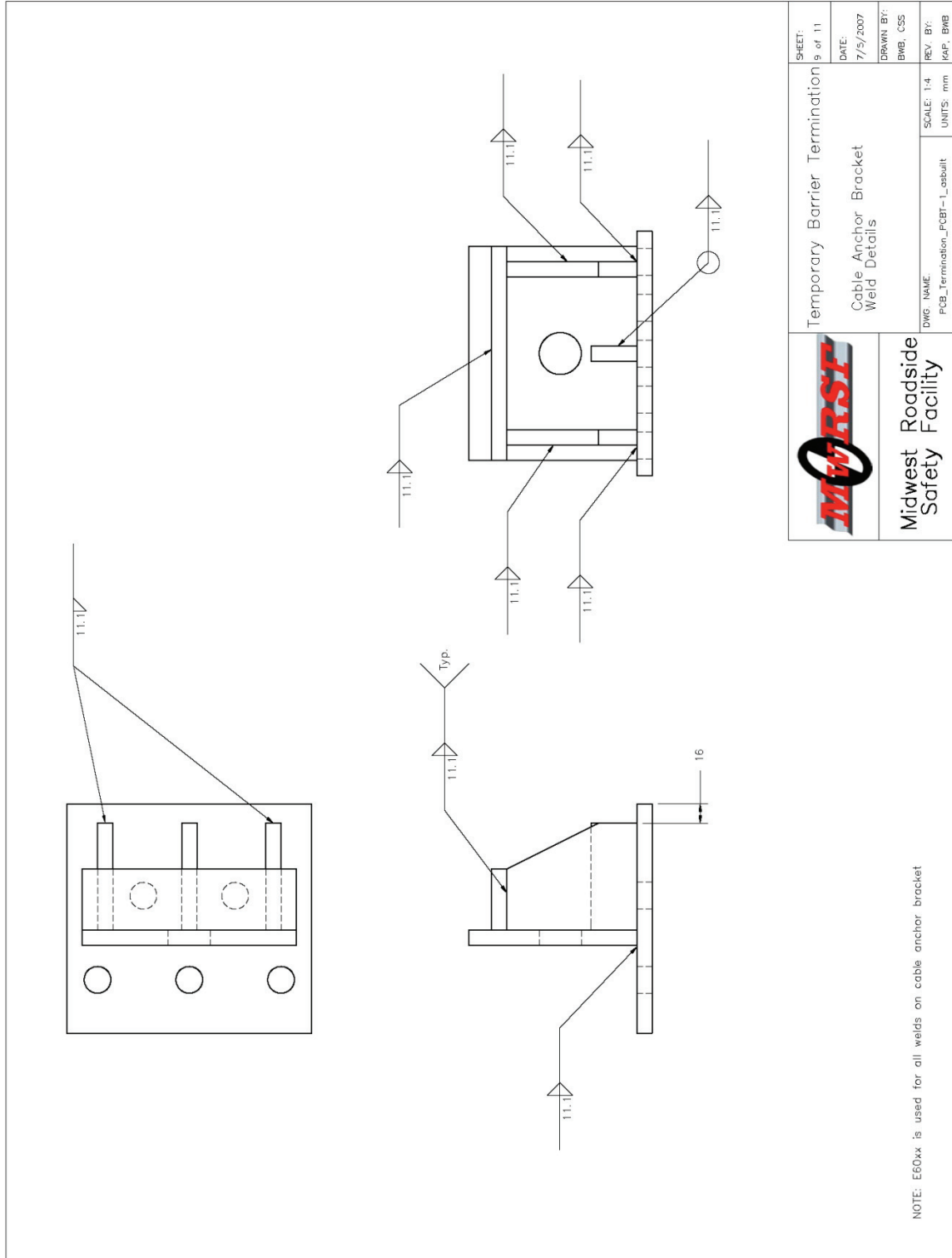

Figure A-9. Termination of Temporary Concrete Barrier, Test No. TTCB-1

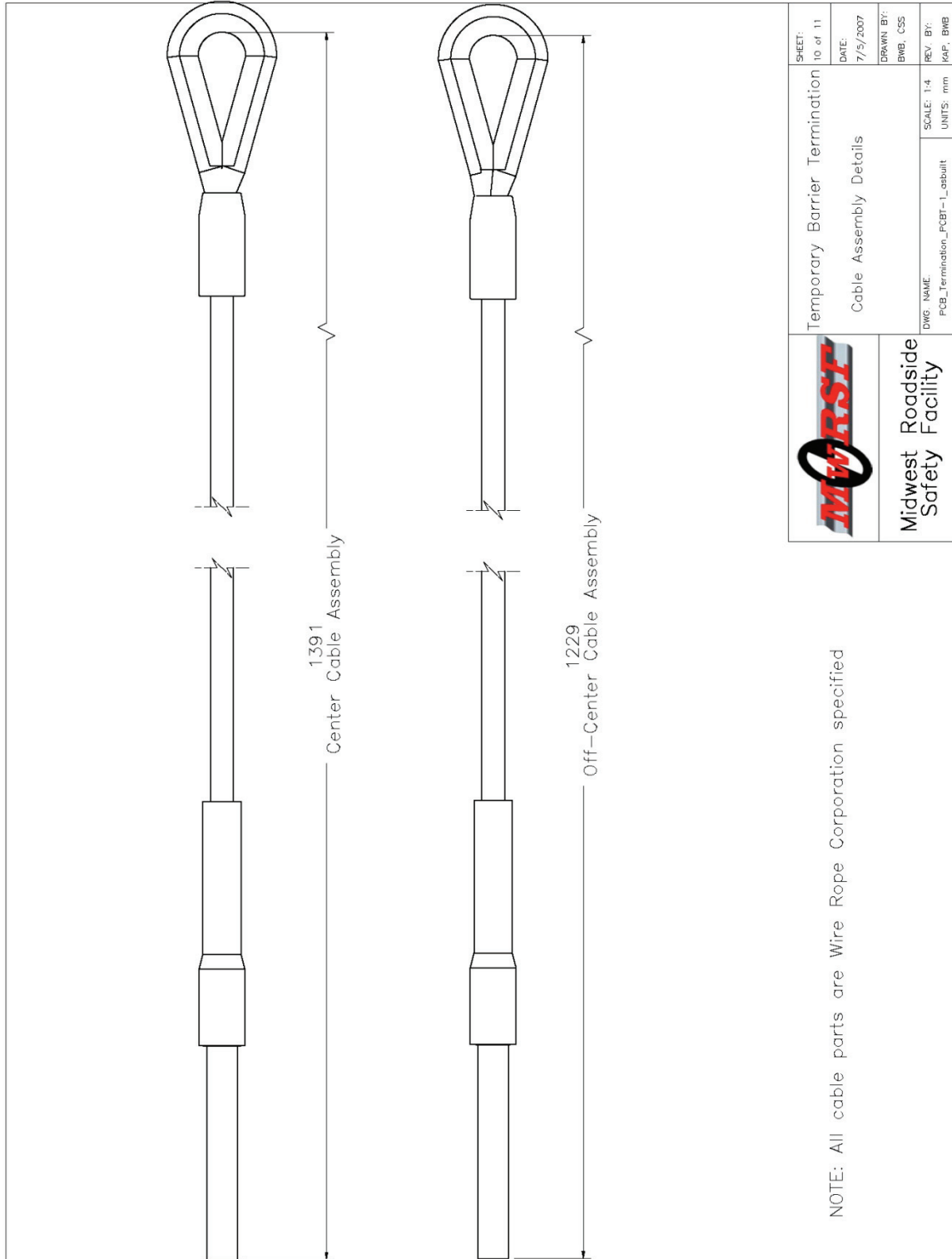
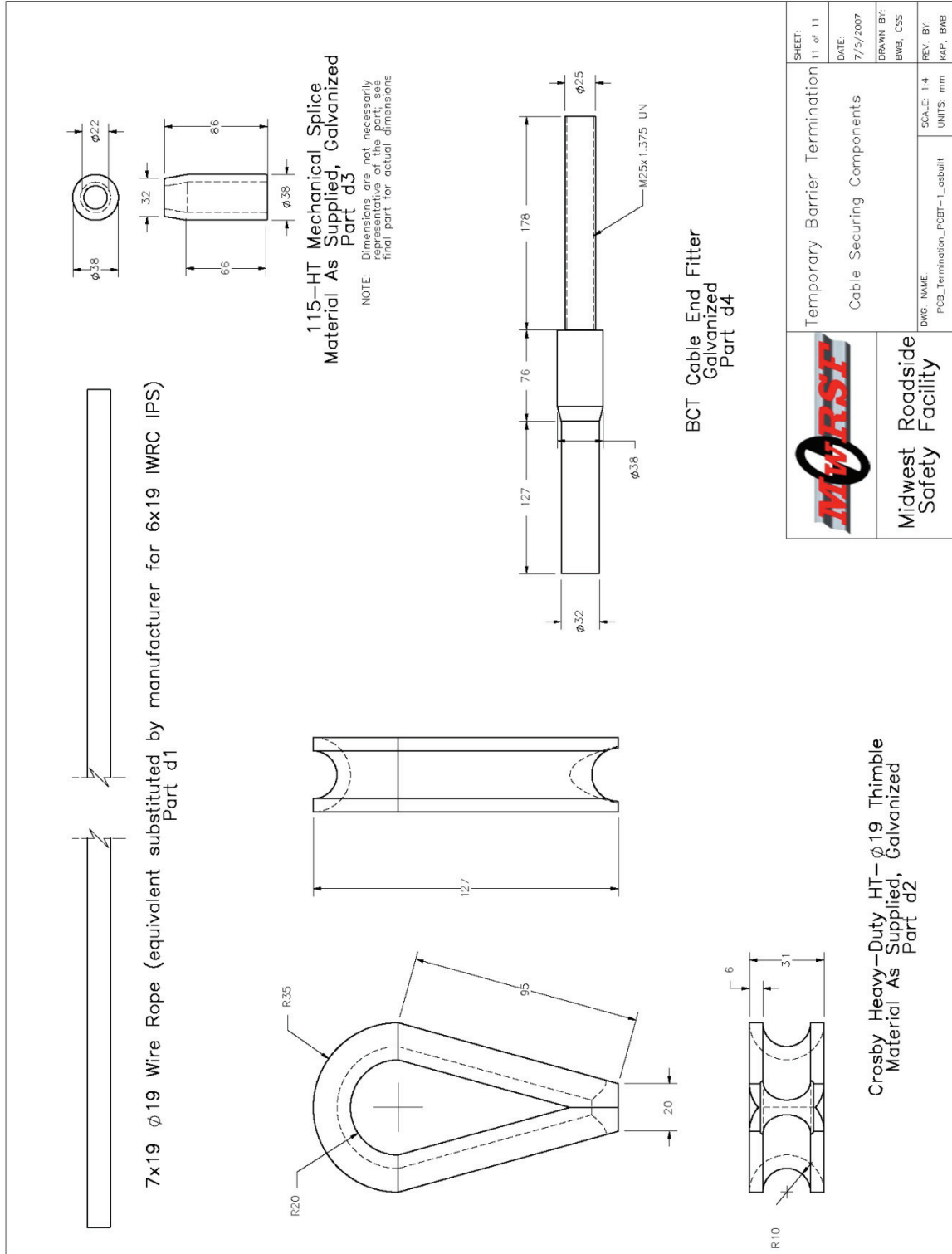

Figure A-10. Termination of Temporary Concrete Barrier, Test No. TTCB-1



 Midwest Safety Roadside Facility	Temporary Barrier Termination Cable Securing Components	SHEET: 11 of 11 DATE: 7/5/2007 DRAWN BY: BWB, CSS REV. BY: KAP, BMB
	DWG. NAME: PCB_Termination_PCBT-L_asbuilt SCALE: 1:4 UNITS: mm	

Figure A-11. Termination of Temporary Concrete Barrier, Test No. TTCB-1

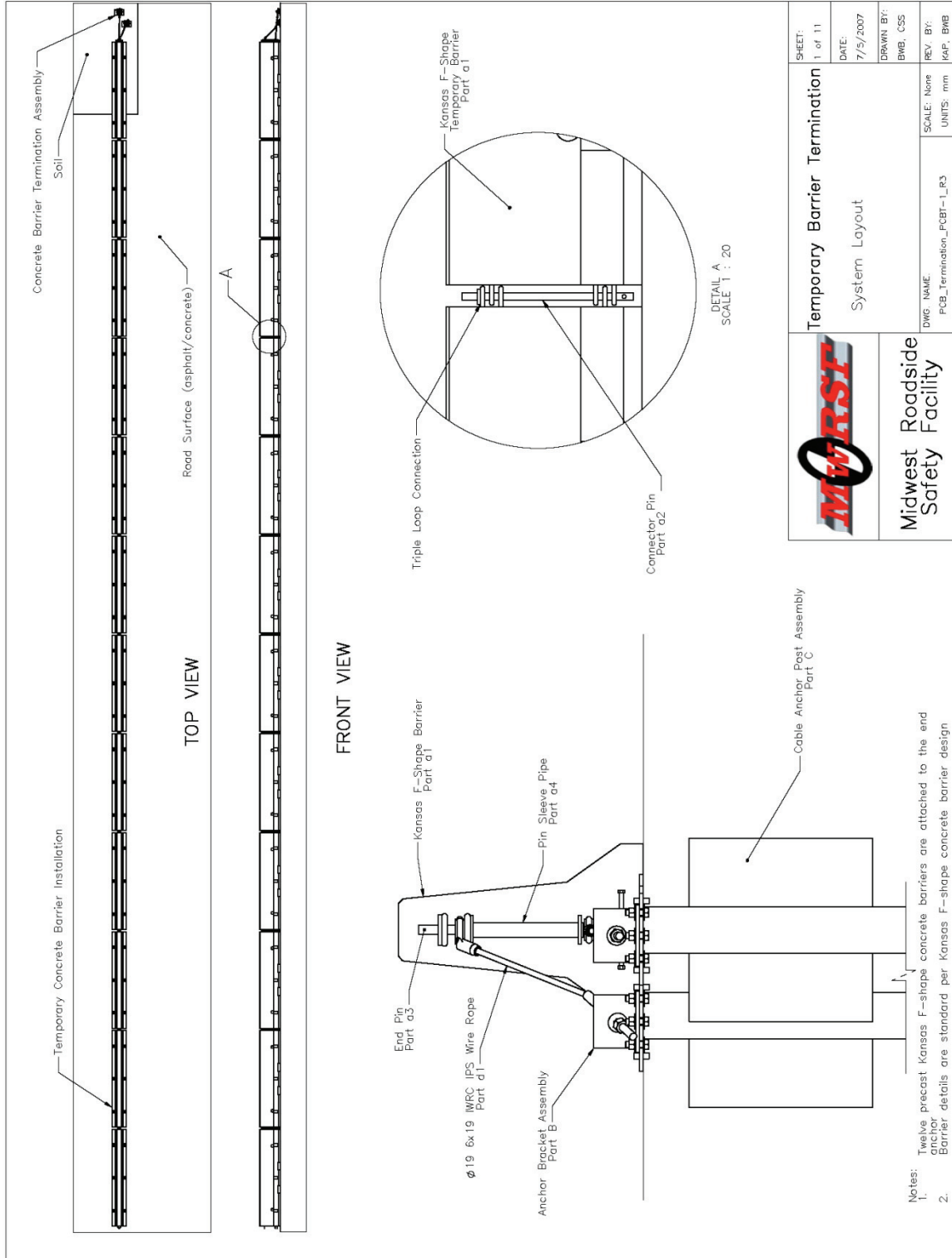

Figure A-13. Termination of Temporary Concrete Barrier, Final Design Details

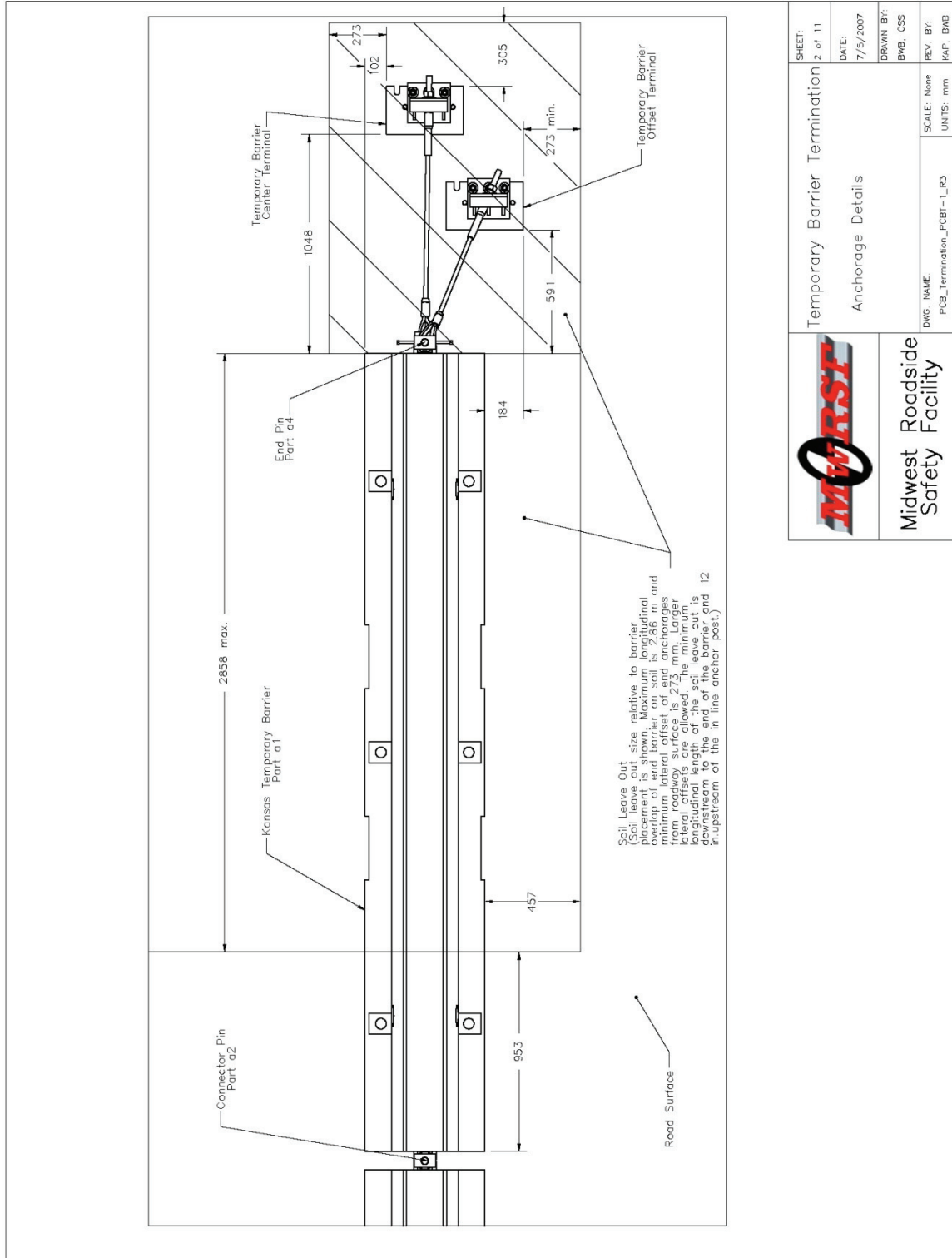
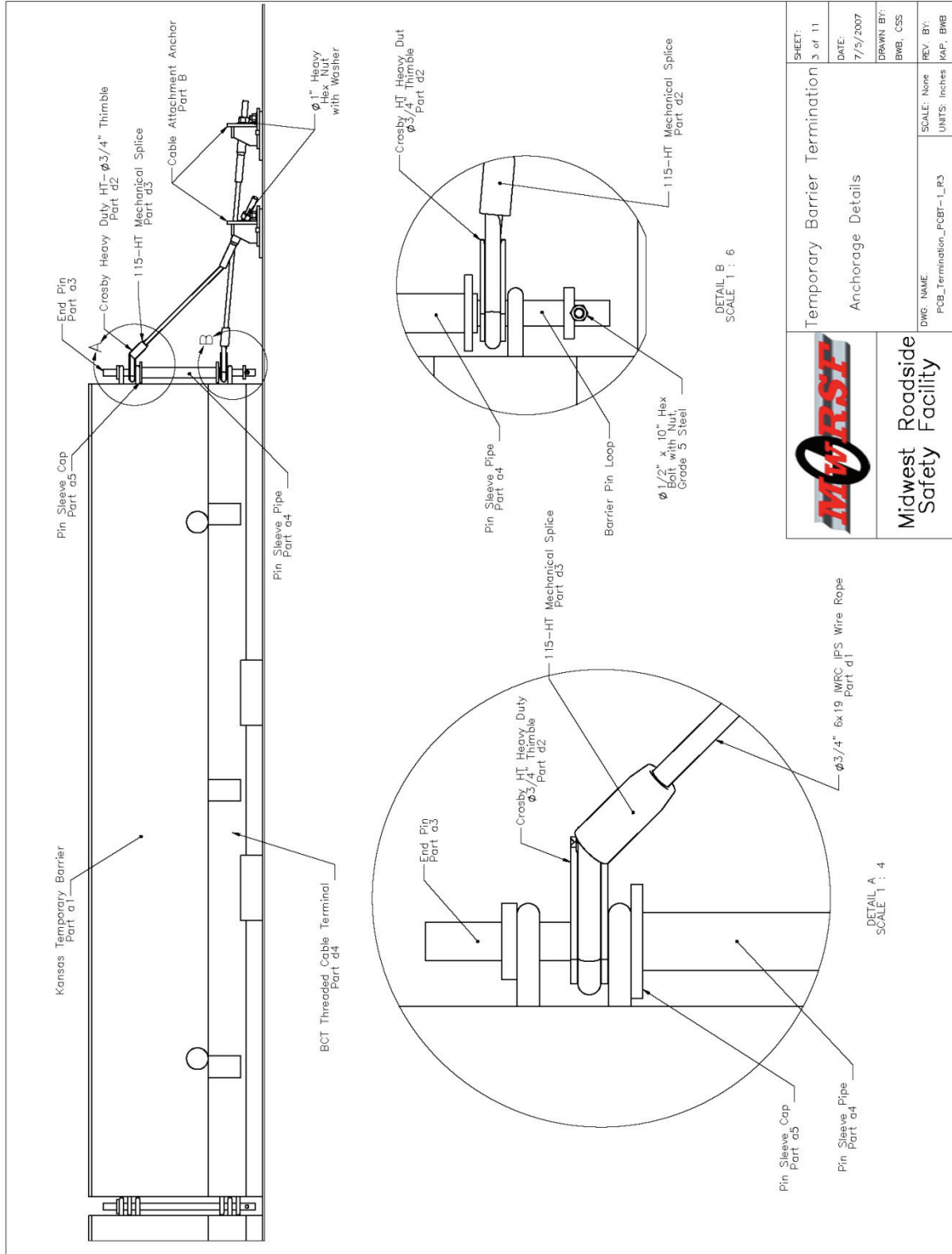
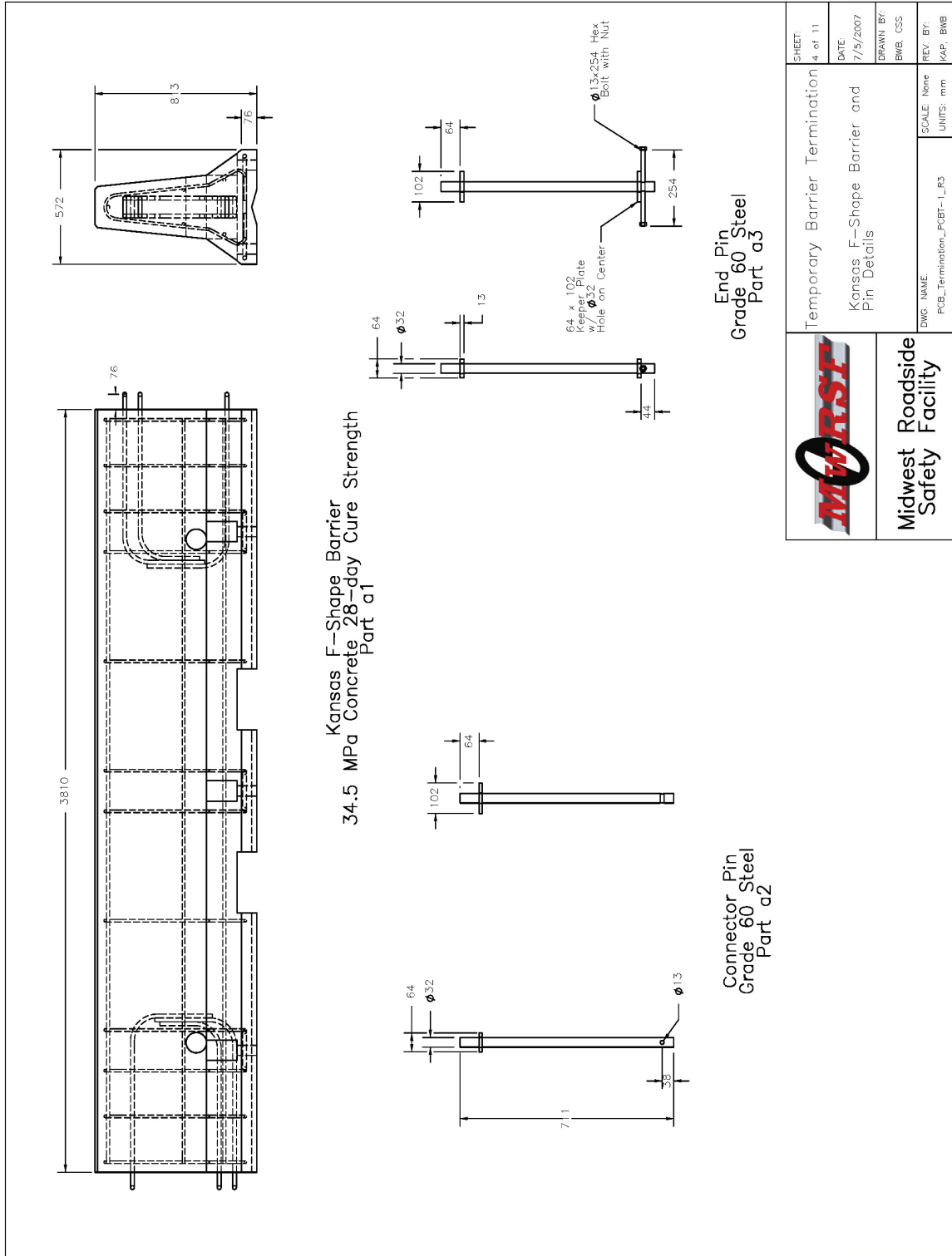

Figure A-14. Termination of Temporary Concrete Barrier, Final Design Details



MwRSF	Temporary Barrier Termination		SHEET: 3 of 11
	Anchorage Details		DATE: 7/5/2007
Midwest Roadside Safety Facility			DRAWN BY: BMB, CSS
			REV. BY: KAP, BMB
DWG. NAME: PCB_Termination_PCBT-LR3		SCALE: None	UNITS: Inches

Figure A-15. Termination of Temporary Concrete Barrier, Final Design Details



 Midwest Roadside Safety Facility	Temporary Barrier Termination Kansas F-Shape Barrier and Pin Details	SHEET: 4 of 11 DATE: 7/5/2007 DRAWN BY: BWB, CSS REV. BY: KAP, BWB
	DWG. NAME: PCB_Termination_PCBET-1_R3 SCALE: None UNITS: mm	

Figure A-16. Termination of Temporary Concrete Barrier, Final Design Details



	Temporary Barrier Termination Pin Sleeve Details	SHEET: 5 of 11 DATE: 7/5/2007 DRAWN BY: BMB, CSS REV. BY: KAP, BMB SCALE: None UNITS: mm
	Midwest Safety Roadside Facility	DWG. NAME: PCB_Termination_PCBT-LR3

Figure A-17. Termination of Temporary Concrete Barrier, Final Design Details

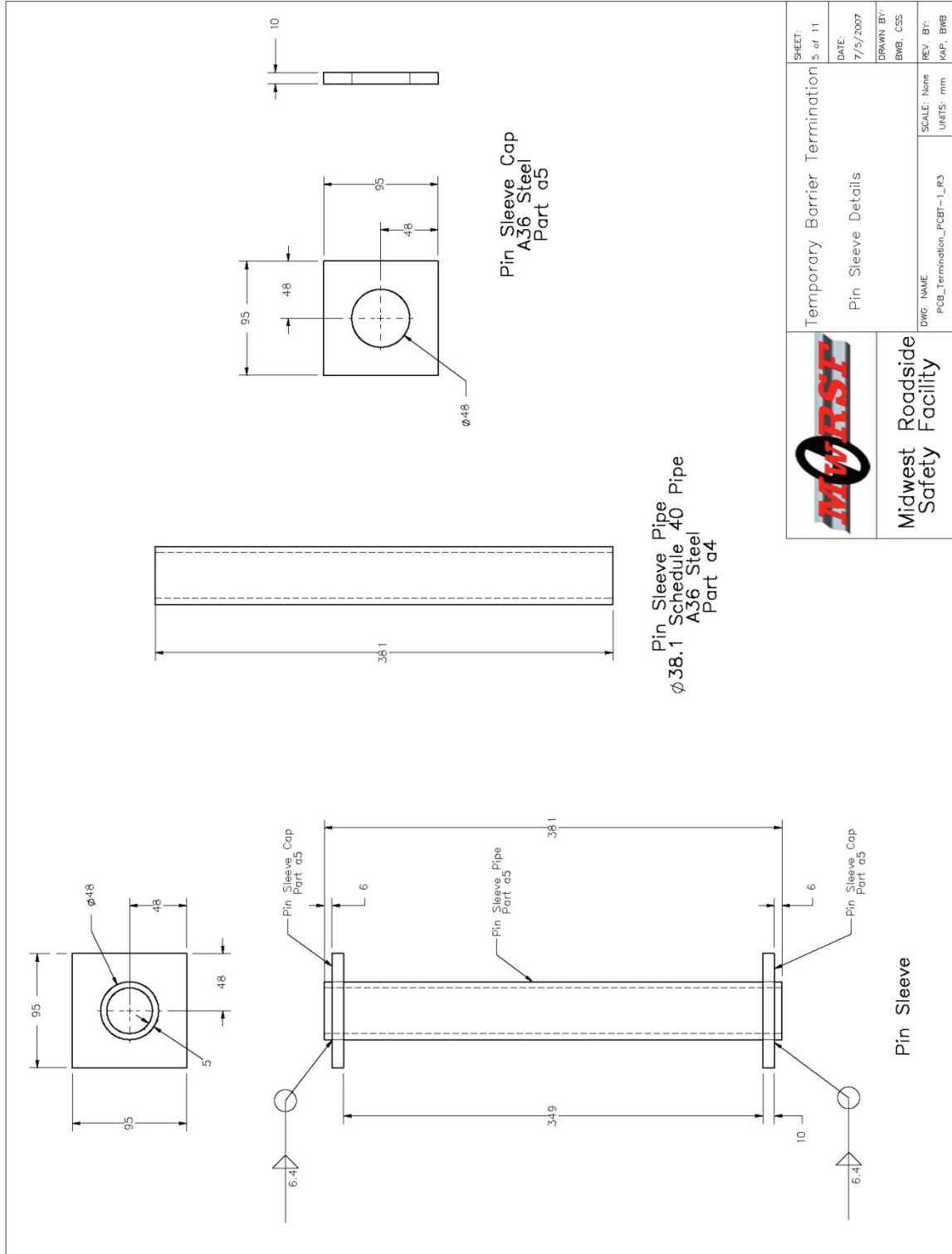
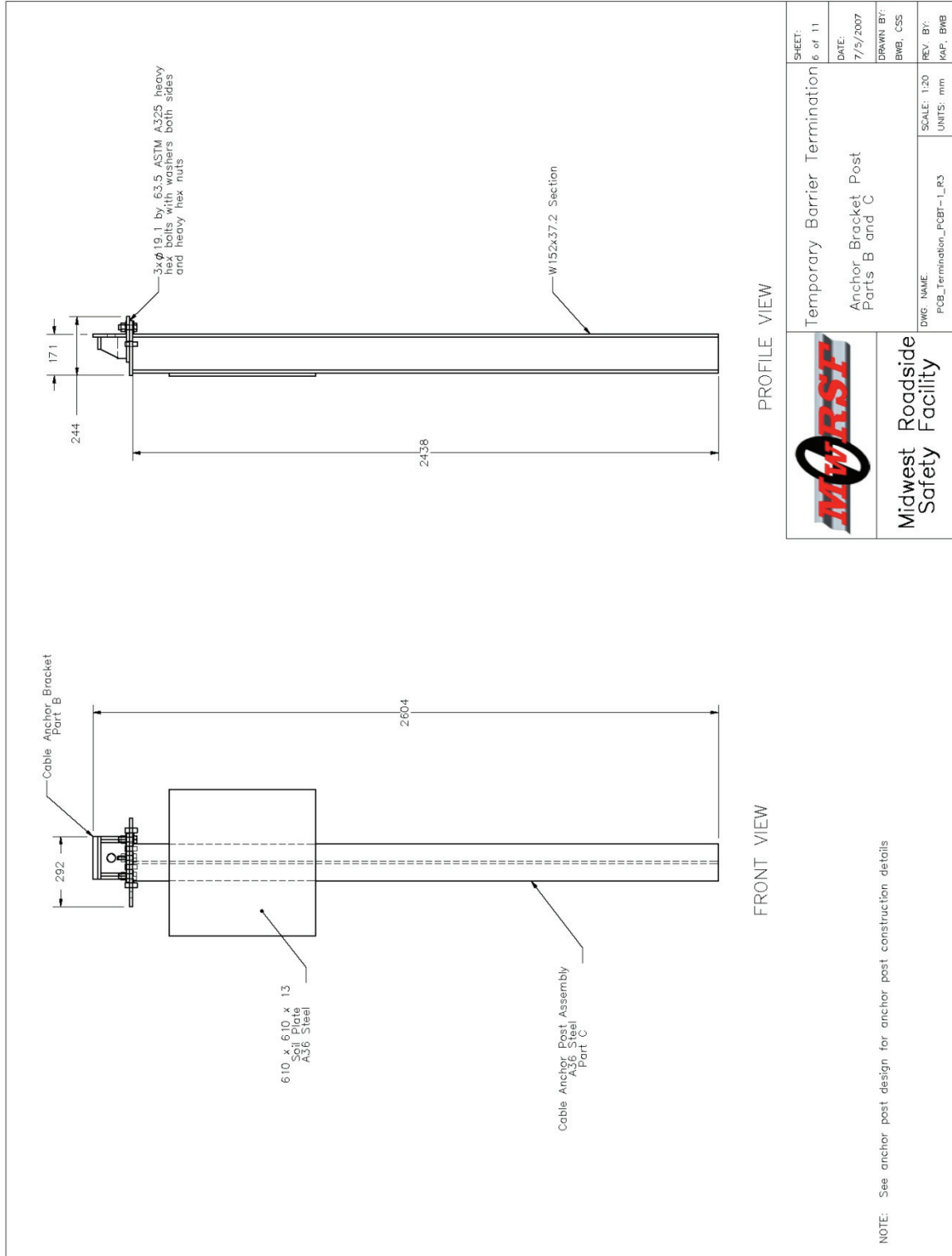

Figure A-18. Termination of Temporary Concrete Barrier, Final Design Details

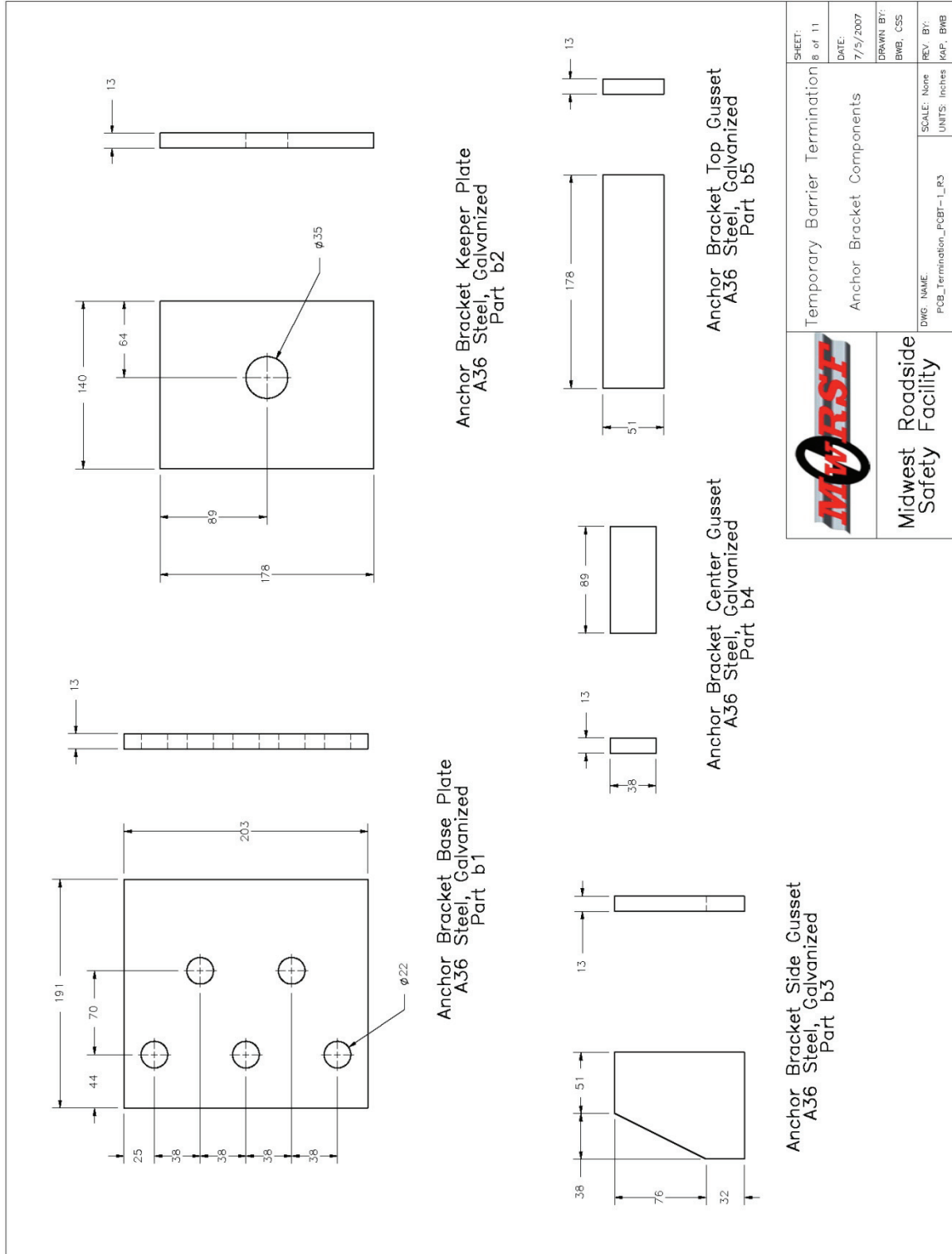

Figure A-20. Termination of Temporary Concrete Barrier, Final Design Details

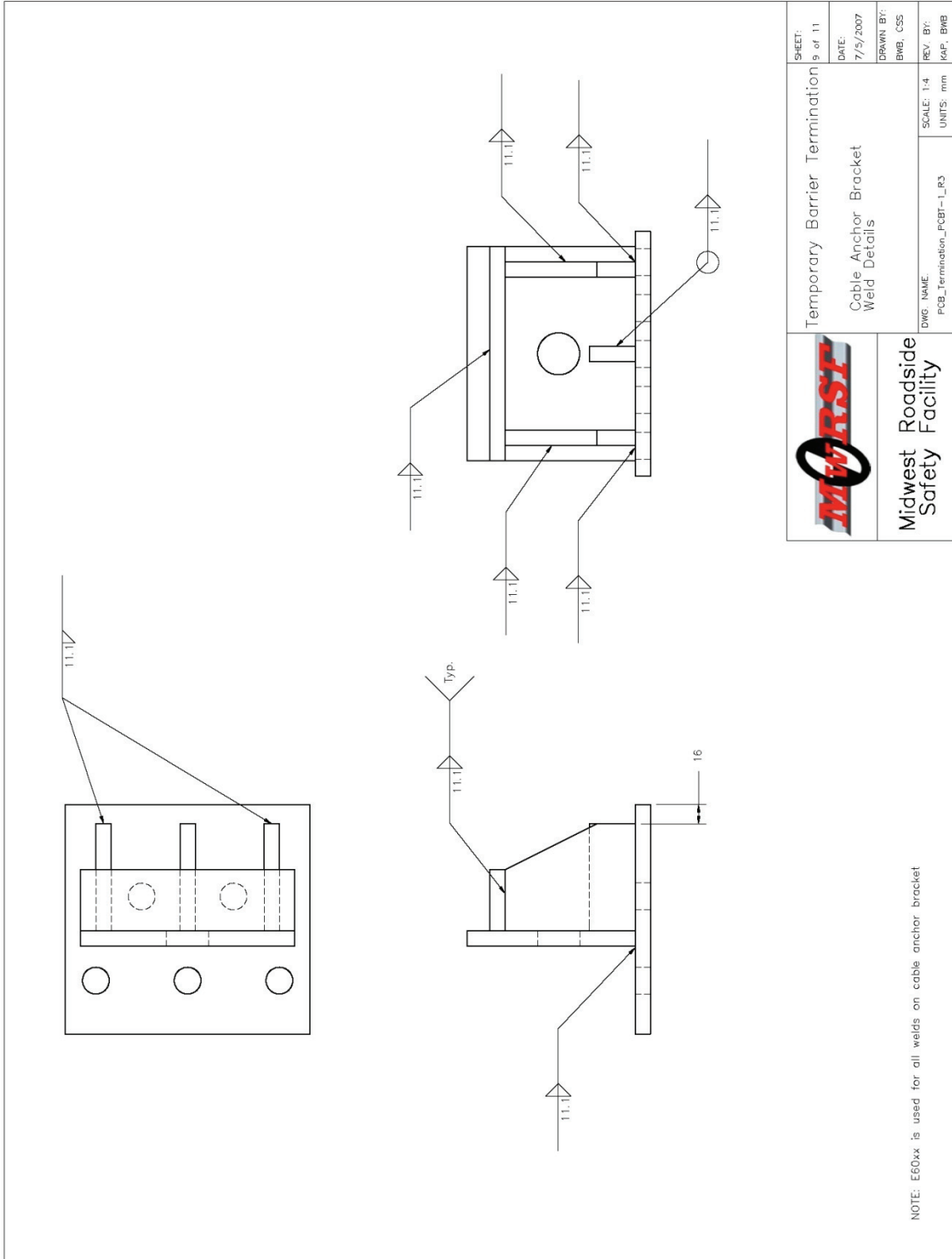

Figure A-21. Termination of Temporary Concrete Barrier, Final Design Details

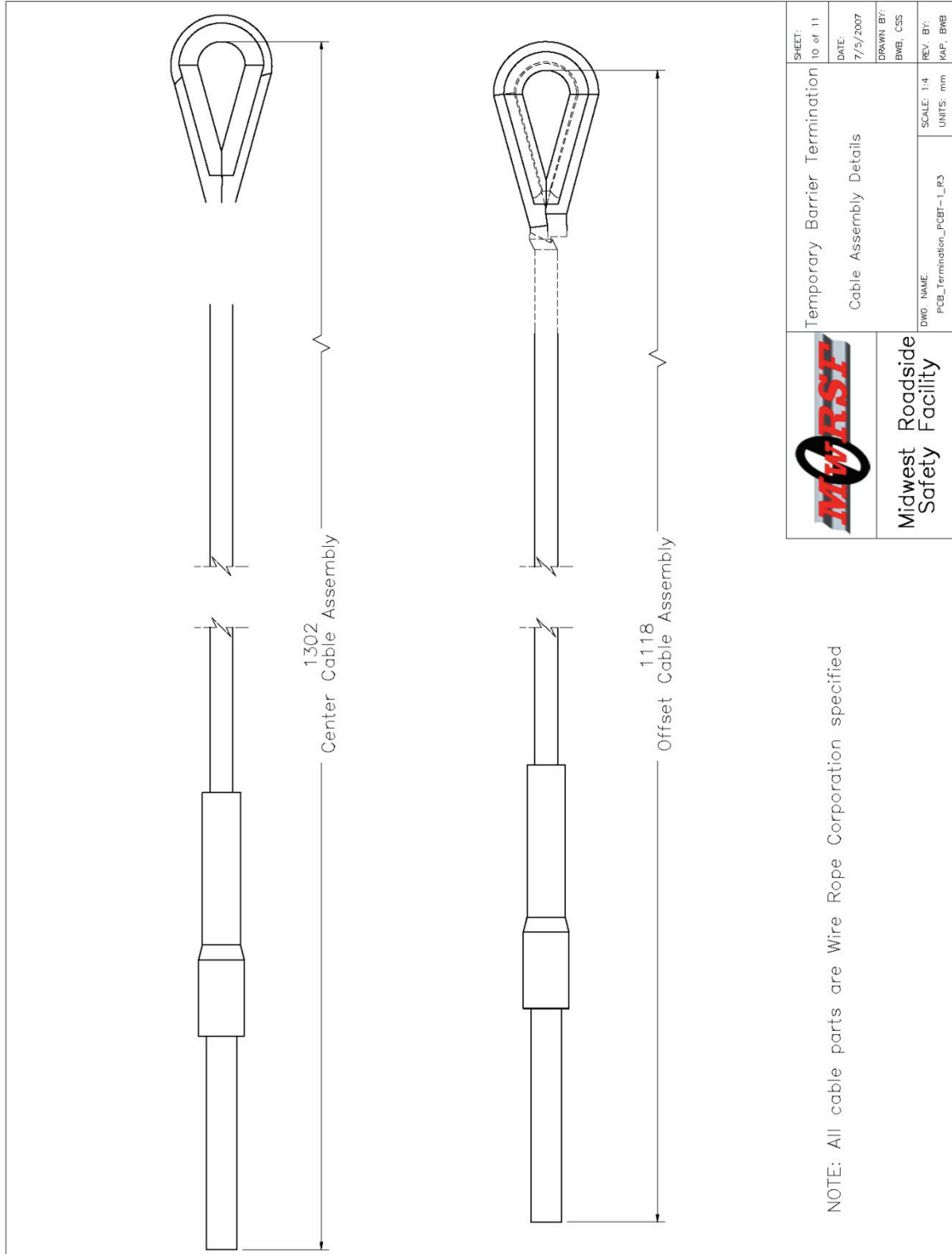

Figure A-22. Termination of Temporary Concrete Barrier, Final Design Details

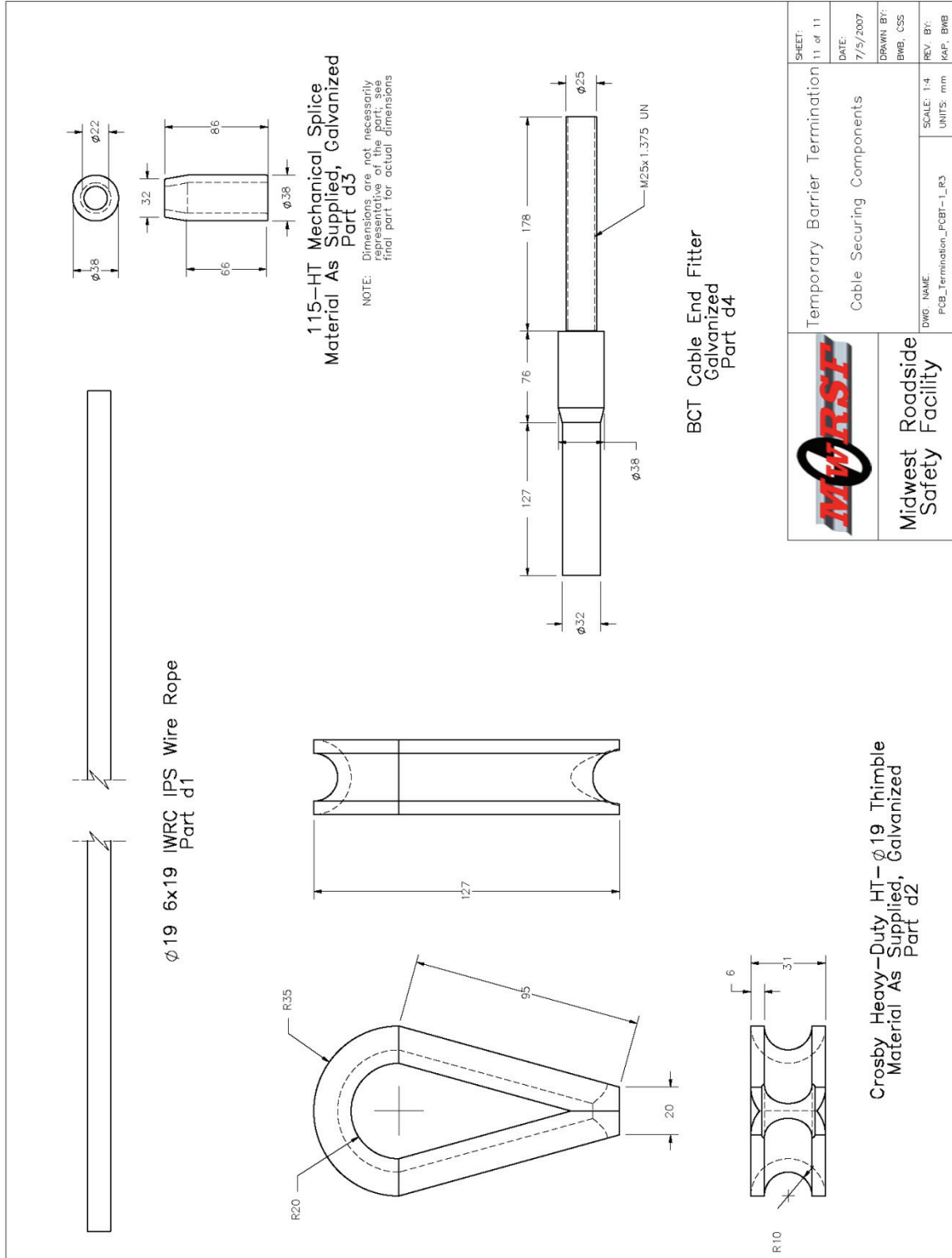

Figure A-23. Termination of Temporary Concrete Barrier, Final Design Details

APPENDIX B. Vehicle Center of Gravity Determination

Test: TTCB-1		Vehicle: 2003 Dodge Ram 1500 Q.C				
Vehicle CG Determination						
VEHICLE	Equipment	Weight	Long CG	Vert CG	HOR M	Vert M
+	Unbalasted Truck	4988	61.875	28.2	308632.5	140661.6
+	Brake receivers/wires	5	106	51	530	255
+	Brake Frame	13	35	29	455	377
+	Brake Cylinder	27	74	31	1998	837
+	Strobe Battery	6	74	30	444	180
+	Hub	27	0	15.125	0	408.375
+	CG Plate (EDRs)	8	54	32	432	256
-	Battery				0	0
-	Oil	-11	8	19	-88	-209
-	Interior	-54	44	24	-2376	-1296
-	Fuel	-159	111	20	-17649	-3180
-	Coolant	-17	-18	35	306	-595
-	Washer fluid	-2	-15	35	30	-70
BALLAST	Water	169	111	20	18759	3380
	Misc.		0	0	0	0
	Misc.		0	0	0	0
TOTAL WEIGHT		5000			311473.5	141005
					62.2947	28.201

wheel base 140.25

NCHRP 350 Targets	CURRENT	Difference
Test Inertial Weight	5000	0.0
Long CG	62.29	0.29470
Vert CG	28.20	0.20100

Note, Long. CG is measured from front axle of test vehicle

Curb Weight		
	Left	Right
Front	1402	1387
Rear	1084	1115
FRONT	2789	
REAR	2199	
TOTAL	4988	

Actual test inertial weight		
	Left	Right
Front	1370	1404
Rear	1113	1104
FRONT	2774	
REAR	2217	
TOTAL	4991	

Figure. B-1. Vehicle Mass Distribution, Test No. TTCB-1

APPENDIX C. Summary of Test Results in Metric Units

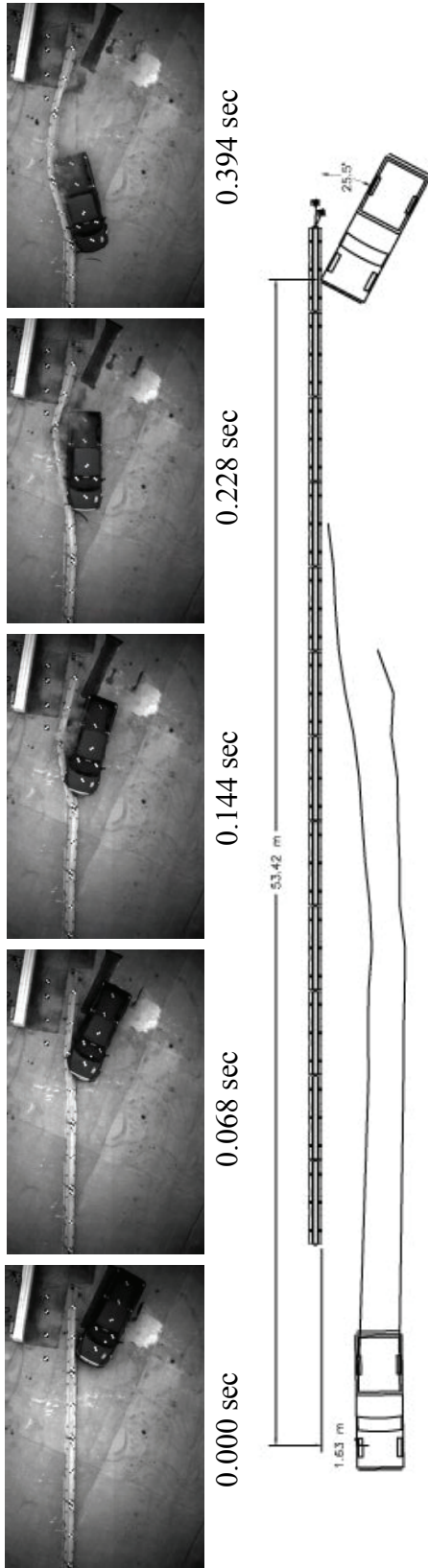

• Test Agency	MwRSF	• Vehicle Stability	Satisfactory
• Test Number	TTCB-1	• Occupant Ridedown Deceleration (10 msec avg.) (EDR-3)	
• Date	6/27/07	Longitudinal	-16.47 g's < 20.49 g's
• MASH Test Designation	3-35	Lateral	-8.00 g's < 20.49 g's
• Test Article	Termination of Temporary Concrete Barrier	• Occupant Impact Velocity (EDR-3)	
• System Length	47.7 m	Longitudinal	-4.09 m/s < 12.2 m/s
• Temporary Concrete Barriers		Lateral	-5.23 m/s < 12.2 m/s
Type	Precast Kansas F-Shape	• Occupant Ridedown Deceleration (10 msec avg.) (EDR-4)	
Quantity	12	Longitudinal	-10.36 g's < 20.49 g's
Length	3.81 m	Lateral	-8.04 g's < 20.49 g's
Base Width	572 mm	• Occupant Impact Velocity (EDR-4)	
Height	813 mm	Longitudinal	-4.28 m/s < 12.2 m/s
• Anchorage Components		Lateral	-4.88 m/s < 12.2 m/s
Cables	19 mm Diameter 6x19 IWRC Wire Rope	• THIV (not required)	6.63 m/s
Cable Assembly Lengths	2195 & 1168 mm	• PHD (not required)	16.78 g's
Post Type	W152x37.2	• Vehicle Damage	Moderate
Post Length (Embedment)	2.44 m	VDS ^[15]	1-FR-6 and 1-RD-3
Vehicle Make and Model	2003 Dodge Ram 1500 Quad Cab	CDC ^[16]	01-FREN2 and 01-RDES2
Curb	2,263 kg	Maximum Interior Deformation	108 mm near RF corner of the floorboard
Test Inertial	2,264 kg	• Vehicle Stopping Distance	53.4 m DS of impact, 1.6 m Laterally
Gross Static	2,264 kg	• Test Article Damage	Minimal
• Impact Conditions		• Test Article Deflections	
Speed	101.3 km/h	Permanent Set	1,689 mm
Angle	25.5 deg	Dynamic	NA
Impact Location	2.76 m DS from US End of Barrier 1	Working Width	2,261 mm
• Exit Conditions		• Maximum Roll Angle	14.75 deg @ 0.693 sec
Speed	58.1 km/h		
Angle	15.9 deg		

Figure C-1. Summary of Test Results and Sequential Photographs (Metric), Test No. TTCB-1

APPENDIX D. Occupant Compartment Deformation Data

VEHICLE PRE/POST CRUSH INFO
Set-1

TEST: TTCB-1
VEHICLE: 2003 Dodge Ram 1500 QC

Note: If impact is on driver side need to enter negative number for Y

POINT	X	Y	Z	X'	Y'	Z'	DEL X	DEL Y	DEL Z
1	24	12.75	0	24.5	12.5	0	0.5	-0.25	0
2	28.25	17.5	-2.5	28.25	14.5	-2.5	0	-3	0
3	30.5	22.5	-4	28	22	-1.25	-2.5	-0.5	2.75
4	28.5	28.75	-2	26.25	27.5	1	-2.25	-1.25	3
5	21.75	9.75	-0.25	22	9.5	0	0.25	-0.25	0.25
6	22.5	12.25	-1.5	22.5	12.5	-1.5	0	0.25	0
7	24.25	17.5	-5	24.25	17.25	-5.25	0	-0.25	-0.25
8	25.25	23	-6.75	23	22.75	-4.5	-2.25	-0.25	2.25
9	26	29.75	-6.5	22	29.25	-3	-4	-0.5	3.5
10	18.5	8.5	-1.25	18.5	8.5	-1	0	0	0.25
11	19.75	12.75	-3.5	19.75	13	-3.5	0	0.25	0
12	21.5	17	-7.25	21.5	17.25	-7.5	0	0.25	-0.25
13	22	24	-8.5	20.5	24.25	-7.75	-1.5	0.25	0.75
14	22	30.5	-9	19.5	30.25	-7.25	-2.5	-0.25	1.75
15	13.75	7.5	-1.75	13.75	7.75	-1.5	0	0.25	0.25
16	16.5	12.25	-6.5	16.5	12	-6.5	0	-0.25	0
17	17.75	17	-9.25	17.5	16.5	-9.25	-0.25	-0.5	0
18	18	23.5	-9.5	17.25	23	-9.75	-0.75	-0.5	-0.25
19	17.25	31	-10.5	17	31	-10.75	-0.25	0	-0.25
20	8.5	4	-2	8.5	4	-2.25	0	0	-0.25
21	10.25	12	-8.75	10.5	11.75	-8.75	0.25	-0.25	0
22	10.5	16.75	-9	10.75	16.5	-9.25	0.25	-0.25	-0.25
23	10.25	23.75	-9.25	10.5	23.5	-9.75	0.25	-0.25	-0.5
24	10.75	30	-9.5	10.25	29.5	-9.75	-0.5	-0.5	-0.25
25	1.5	3	-2	1.5	3.25	-1.75	0	0.25	0.25
26	1	13.5	-5.25	1	13	-5.25	0	-0.5	0
27	1	19.75	-5.5	1	19.5	-5.5	0	-0.25	0
28	1	27.25	-5.75	1	27	-5.5	0	-0.25	0.25

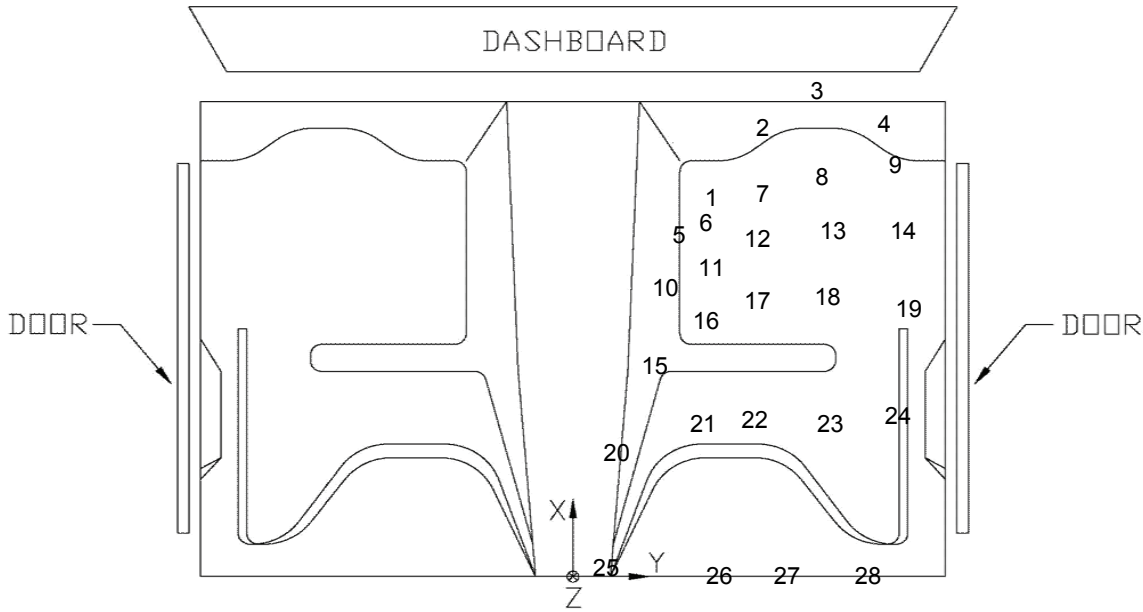

Figure. D-1. Occupant Compartment Deformation Data – Set 1, Test No. TTCB-1

VEHICLE PRE/POST CRUSH INFO
Set-2

TEST: TTCB-1
VEHICLE: 2003 Dodge Ram 1500 QC

Note: If impact is on driver side need to enter negative number for Y

POINT	22.25			-3.25			DEL X	DEL Y	DEL Z
	X	Y	Z	X'	Y'	Z'			
1	46.25	9.5	1	46.75	9.25	1	0.5	-0.25	0
2	50.5	14.25	-1.25	50.5	11.25	-0.5	0	-3	0.75
3	52.75	19.25	-2.25	50.25	18.75	1	-2.5	-0.5	3.25
4	50.75	25.5	0.25	48.5	24.25	4.5	-2.25	-1.25	4.25
5	44	6.5	0.5	44.25	6.25	1	0.25	-0.25	0.5
6	44.75	9	-0.5	44.75	9.25	-0.25	0	0.25	0.25
7	46.5	14.25	-3.75	46.5	14	-3.5	0	-0.25	0.25
8	47.5	19.75	-5	45.25	19.5	-2	-2.25	-0.25	3
9	48.25	26.5	-4	44.25	26	0	-4	-0.5	4
10	40.75	5.25	-0.75	40.75	5.25	-0.25	0	0	0.5
11	42	9.5	-2.75	42	9.75	-2.25	0	0.25	0.5
12	43.75	13.75	-6	43.75	14	-5.75	0	0.25	0.25
13	44.25	20.75	-6.75	42.75	21	-5	-1.5	0.25	1.75
14	44.25	27.25	-6.5	41.75	27	-4.25	-2.5	-0.25	2.25
15	36	4.25	-1.25	36	4.5	-0.75	0	0.25	0.5
16	38.75	9	-5.5	38.75	8.75	-5.25	0	-0.25	0.25
17	40	13.75	-8	39.75	13.25	-7.5	-0.25	-0.5	0.5
18	40.25	20.25	-7.75	39.5	19.75	-7.5	-0.75	-0.5	0.25
19	39.5	27.75	-8	39.25	27.75	-7.75	-0.25	0	0.25
20	30.75	0.75	-1.75	30.75	0.75	-1.75	0	0	0
21	32.5	8.75	-7.75	32.75	8.5	-7.75	0.25	-0.25	0
22	32.75	13.5	-7.75	33	13.25	-7.5	0.25	-0.25	0.25
23	32.5	20.5	-7.25	32.75	20.25	-7.5	0.25	-0.25	-0.25
24	33	26.75	-7.25	32.5	26.25	-7	-0.5	-0.5	0.25
25	23.75	-0.25	-1.5	23.75	0	-1.5	0	0.25	0
26	23.25	10.25	-4.25	23.25	9.75	-4	0	-0.5	0.25
27	23.25	16.5	-4	23.25	16.25	-3.75	0	-0.25	0.25
28	23.25	24	-3.25	23.25	23.75	-3	0	-0.25	0.25

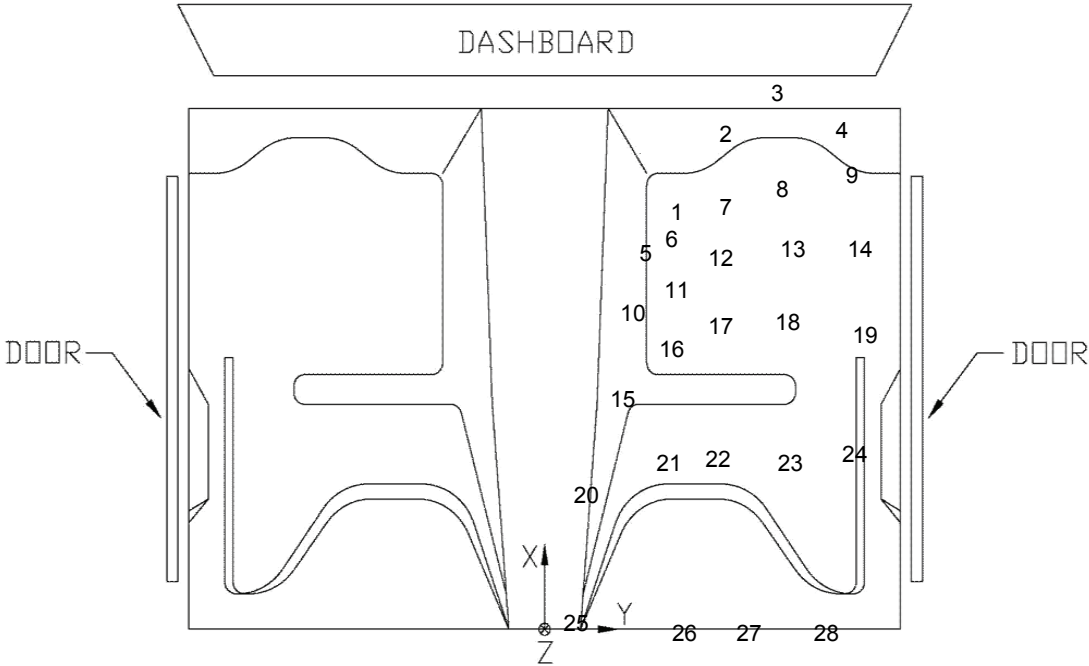

Figure. D-2. Occupant Compartment Deformation Data – Set 2, Test No. TTCB-1

Occupant Compartment Deformation Index (OCDI)

Test No. TTCB-1
Vehicle Type: 2003 Dodge Ram 1500 QC

OCDI = XXABCDEFGHI

XX = location of occupant compartment deformation

A = distance between the dashboard and a reference point at the rear of the occupant compartment, such as the top of the rear seat or the rear of the cab on a pickup

B = distance between the roof and the floor panel

C = distance between a reference point at the rear of the occupant compartment and the motor panel

D = distance between the lower dashboard and the floor panel

E = interior width

F = distance between the lower edge of right window and the upper edge of left window

G = distance between the lower edge of left window and the upper edge of right window

H = distance between bottom front corner and top rear corner of the passenger side window

I = distance between bottom front corner and top rear corner of the driver side window

Severity Indices

- 0 - if the reduction is less than 3%
- 1 - if the reduction is greater than 3% and less than or equal to 10 %
- 2 - if the reduction is greater than 10% and less than or equal to 20 %
- 3 - if the reduction is greater than 20% and less than or equal to 30 %
- 4 - if the reduction is greater than 30% and less than or equal to 40 %

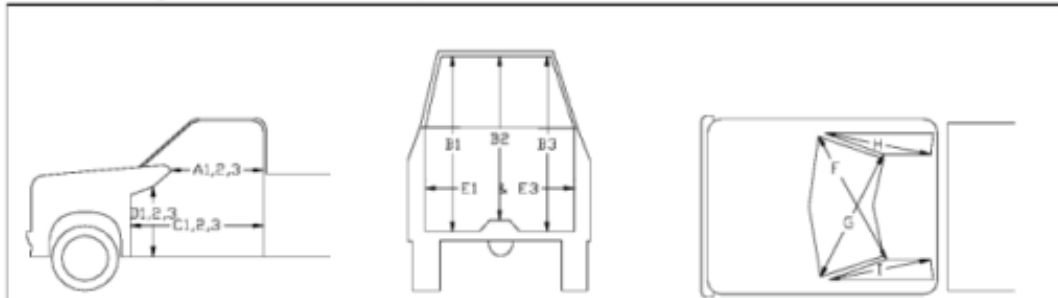

where,
1 = Passenger Side
2 = Middle
3 = Driver Side

Location: Right Front

Measurement	Pre-Test (in.)	Post-Test (in.)	Change (in.)	% Difference	Severity Index
A1	54.50	54.50	0.00	0.00	0
A2	50.25	50.75	0.50	1.00	0
A3	55.00	55.50	0.50	0.91	0
B1	47.25	47.50	0.25	0.53	0
B2	42.75	42.50	-0.25	-0.58	0
B3	47.75	48.75	1.00	2.09	0
C1	66.00	66.50	0.50	0.76	0
C2	46.75	46.75	0.00	0.00	0
C3	66.50	62.50	-4.00	-6.02	1
D1	17.50	17.50	0.00	0.00	0
D2	13.50	13.50	0.00	0.00	0
D3	15.50	15.75	0.25	1.61	0
E1	64.00	65.00	1.00	1.56	0
E3	63.50	63.75	0.25	0.39	0
F	56.75	57.00	0.25	0.44	0
G	56.25	56.25	0.00	0.00	0
H	37.50	37.50	0.00	0.00	0
I	37.75	38.25	0.50	1.32	0

Note: Maximum severity index for each variable (A-I) is used for determination of final OCDI value

Final OCDI: XXABCDEFGHI
RF 0 0 1 0 0 0 0 0 0

Figure. D-3. Occupant Compartment Deformation Index (OCDI), Test No. TTCB-1

APPENDIX E. Accelerometer and Rate Transducer Data Plots

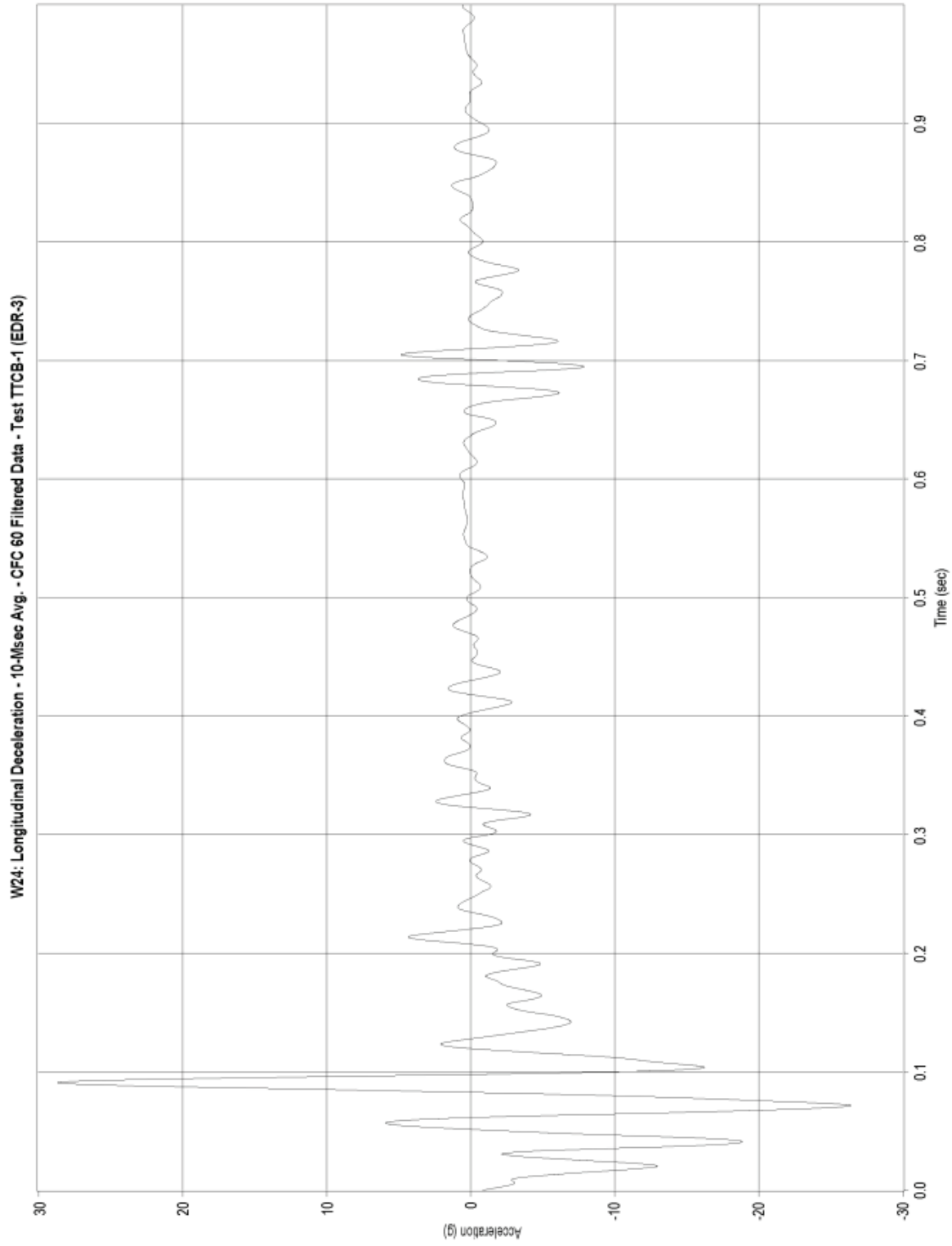

Figure E-1. Graph of 10 ms Average Longitudinal Deceleration (EDR-3), Test No. TTCB-1

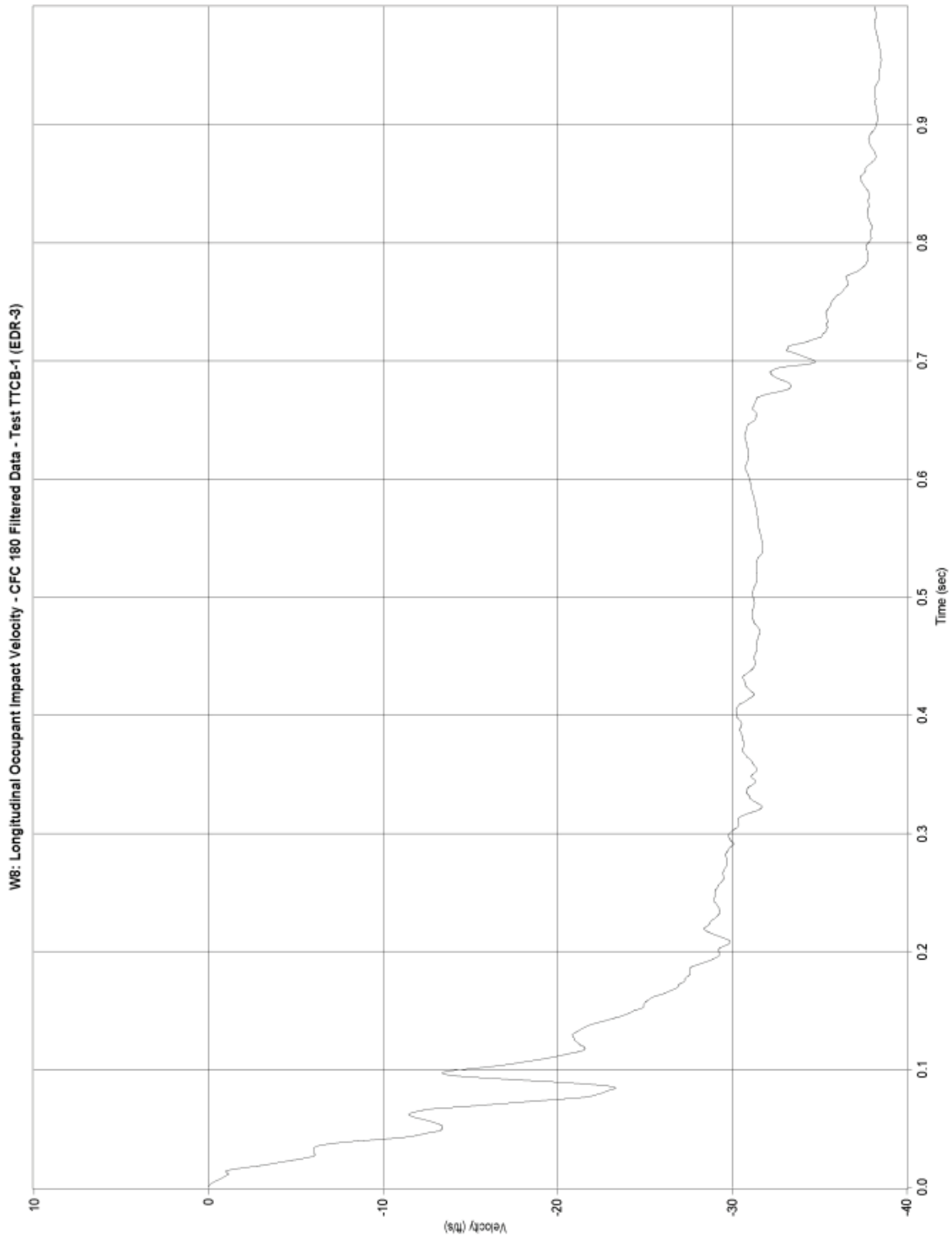

Figure E-2. Graph of Longitudinal Occupant Impact Velocity (EDR-3), Test No. TTCB-1

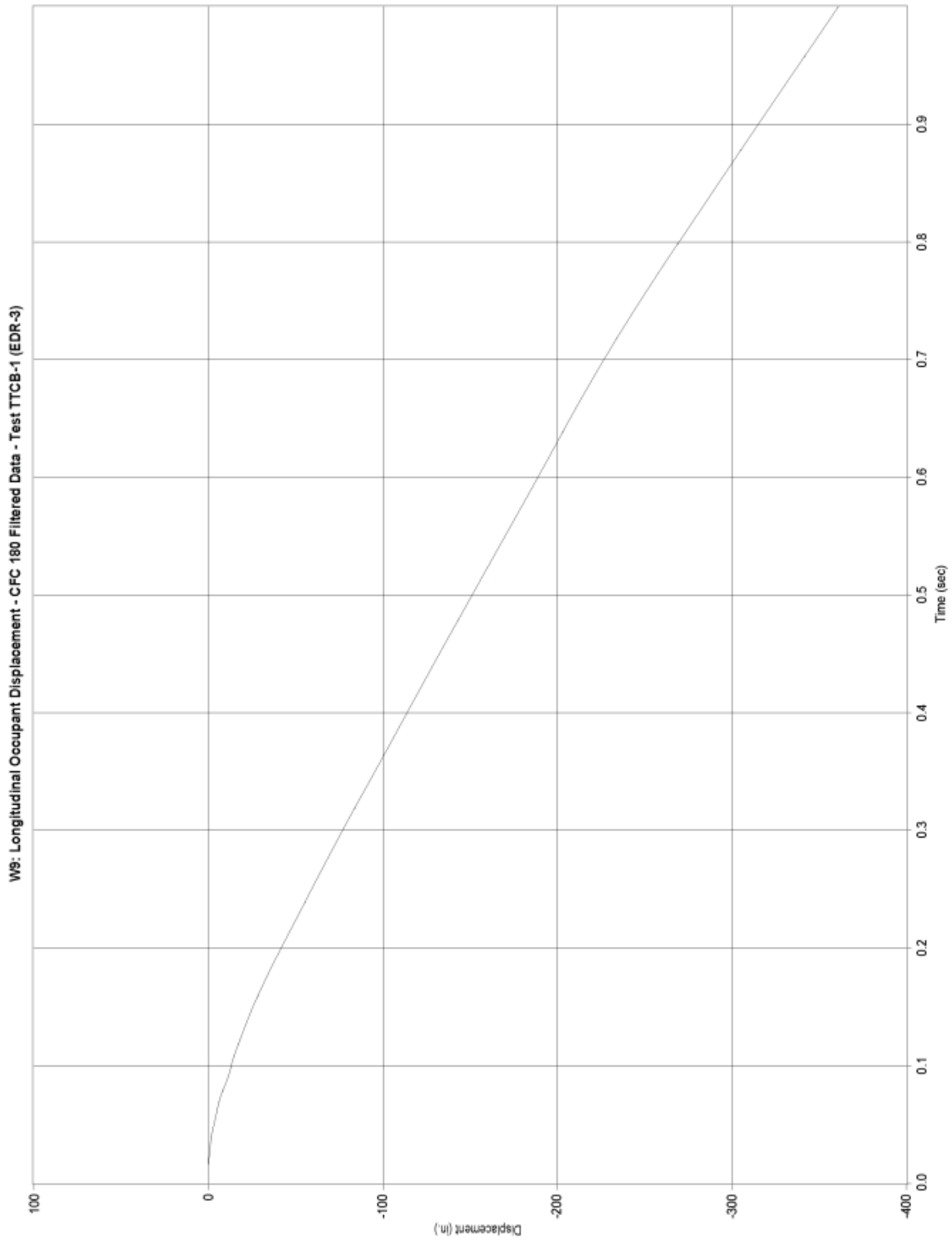

Figure E-3. Graph of Longitudinal Occupant Displacement (EDR-3), Test No. TTCB-1

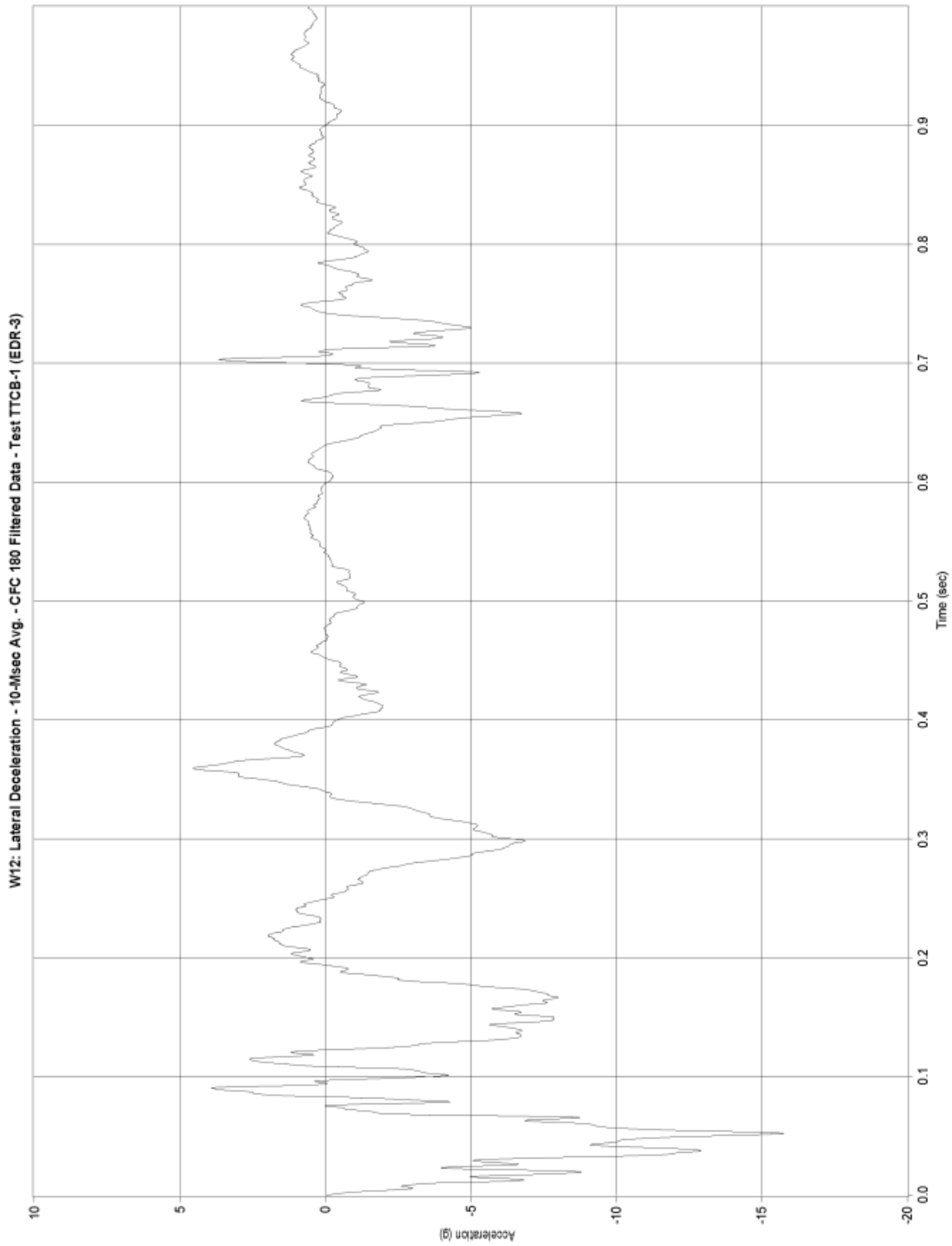

Figure E-4. Graph of 10 ms Average Lateral Deceleration (EDR-3), Test No. TTCB-1

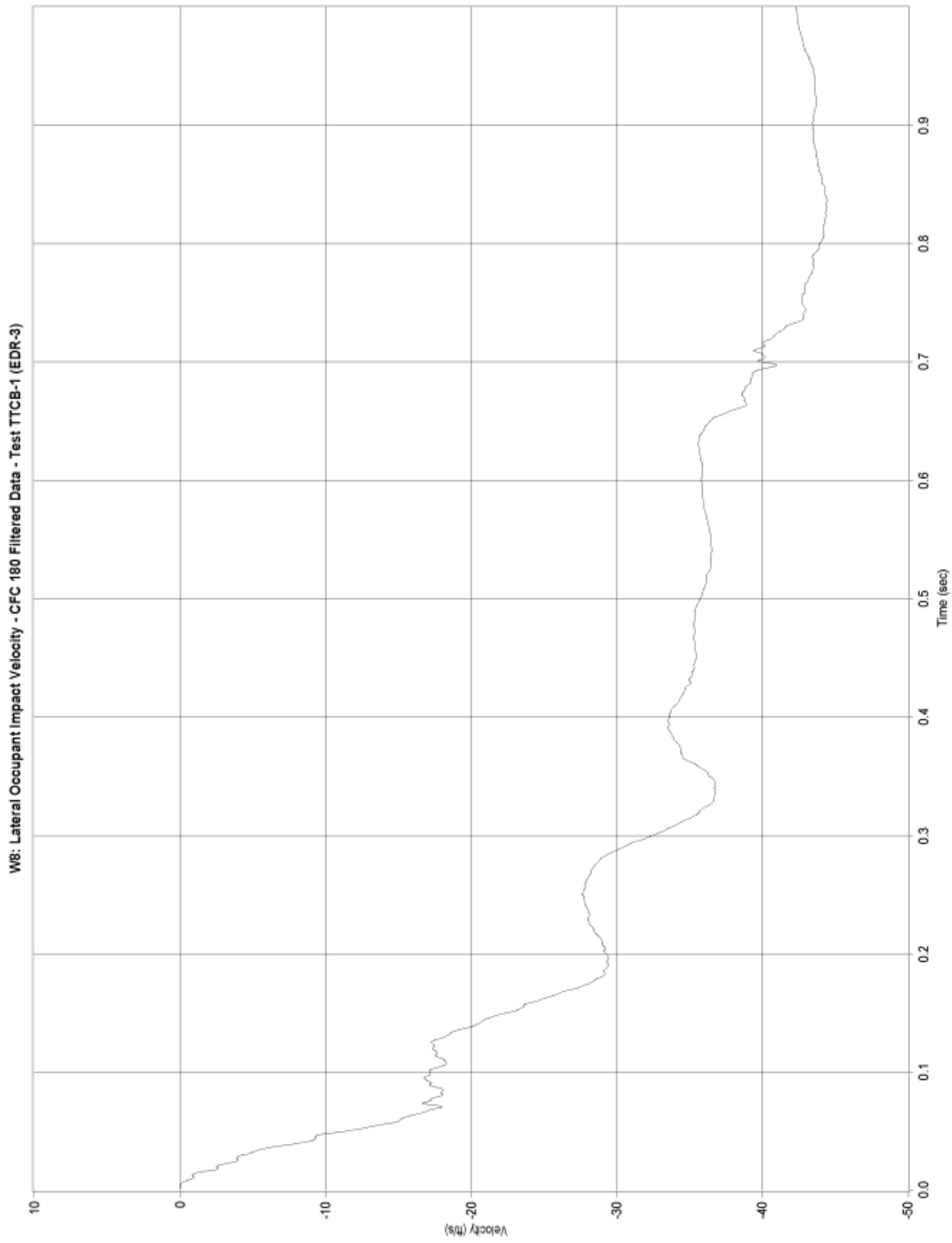

Figure E-5. Graph of Lateral Occupant Impact Velocity (EDR-3), Test No. TTCB-1

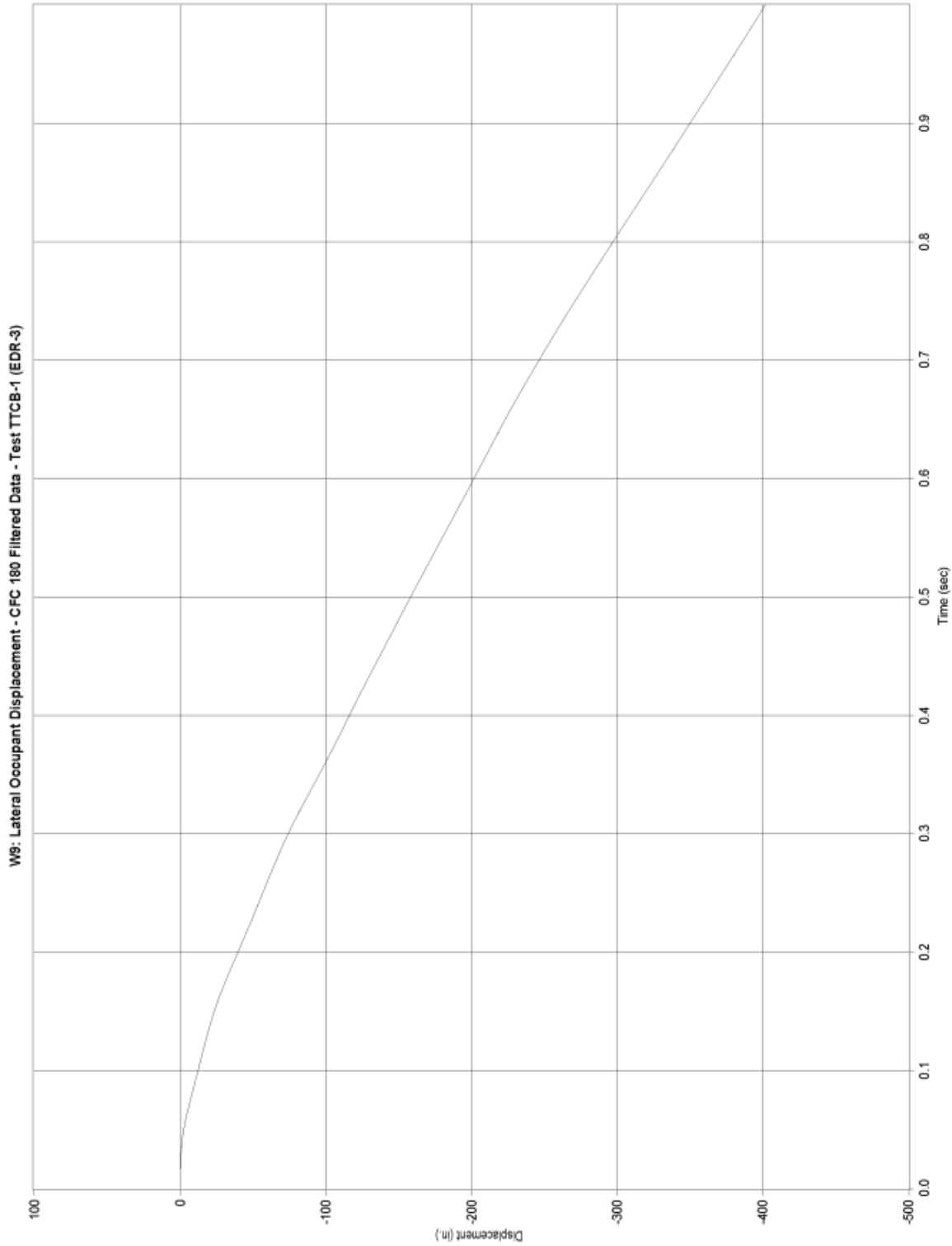

Figure E-6. Graph of Lateral Occupant Displacement (EDR-3), Test No. TTCB-1

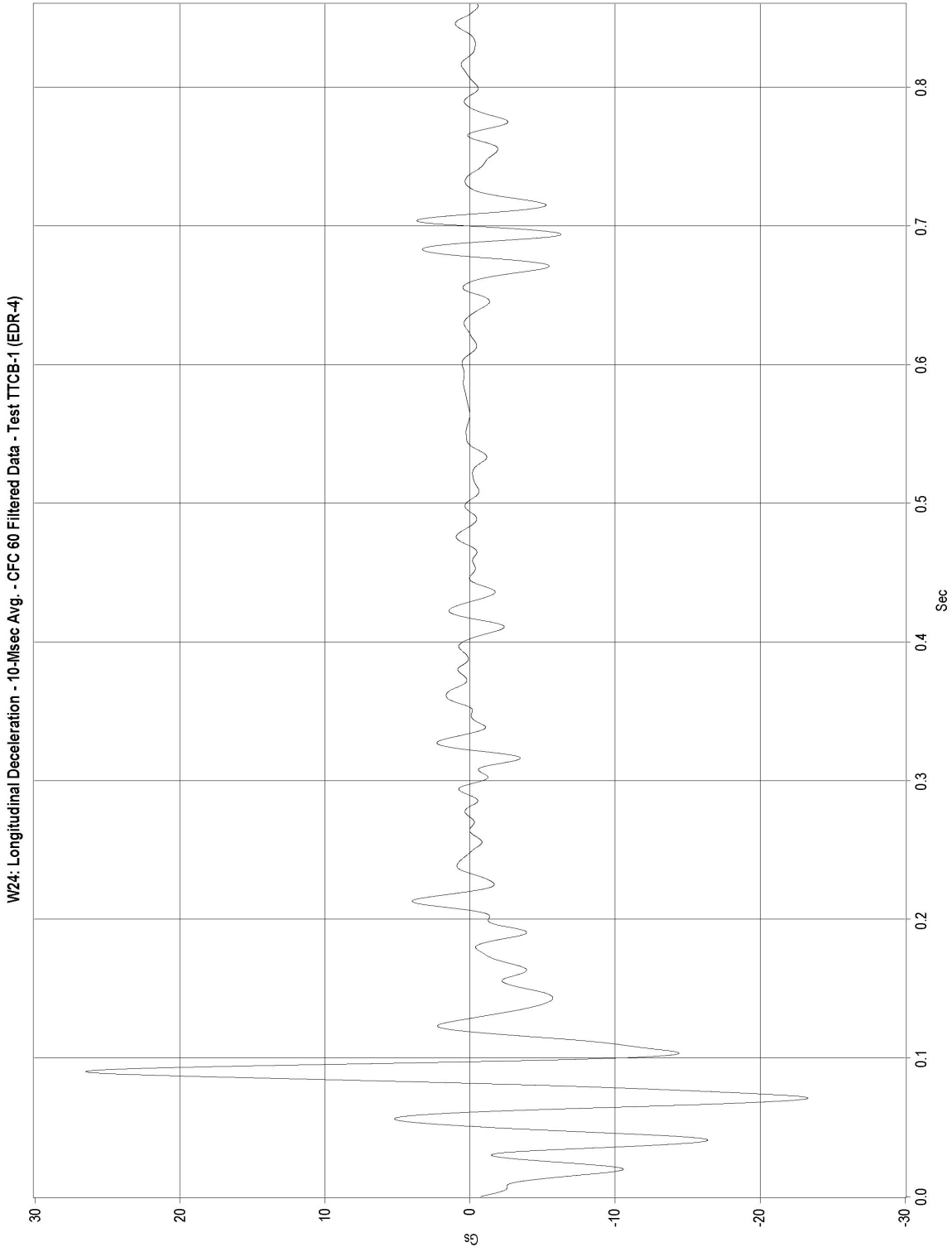

Figure E-7. Graph of 10 ms Average Longitudinal Deceleration (EDR-4), Test No. TTCB-1

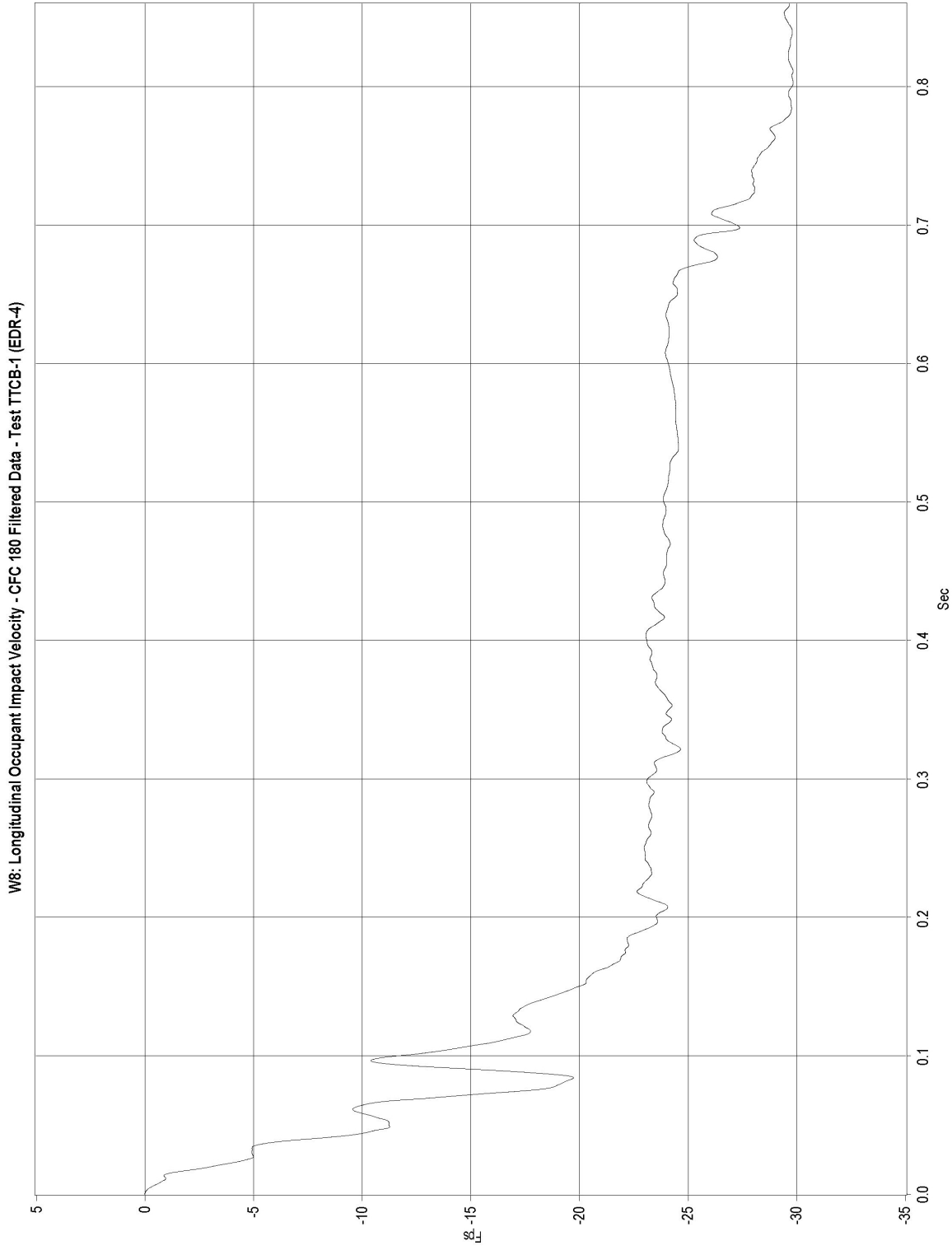

Figure E-8. Graph of Longitudinal Occupant Impact Velocity (EDR-4), Test No. TTCB-1

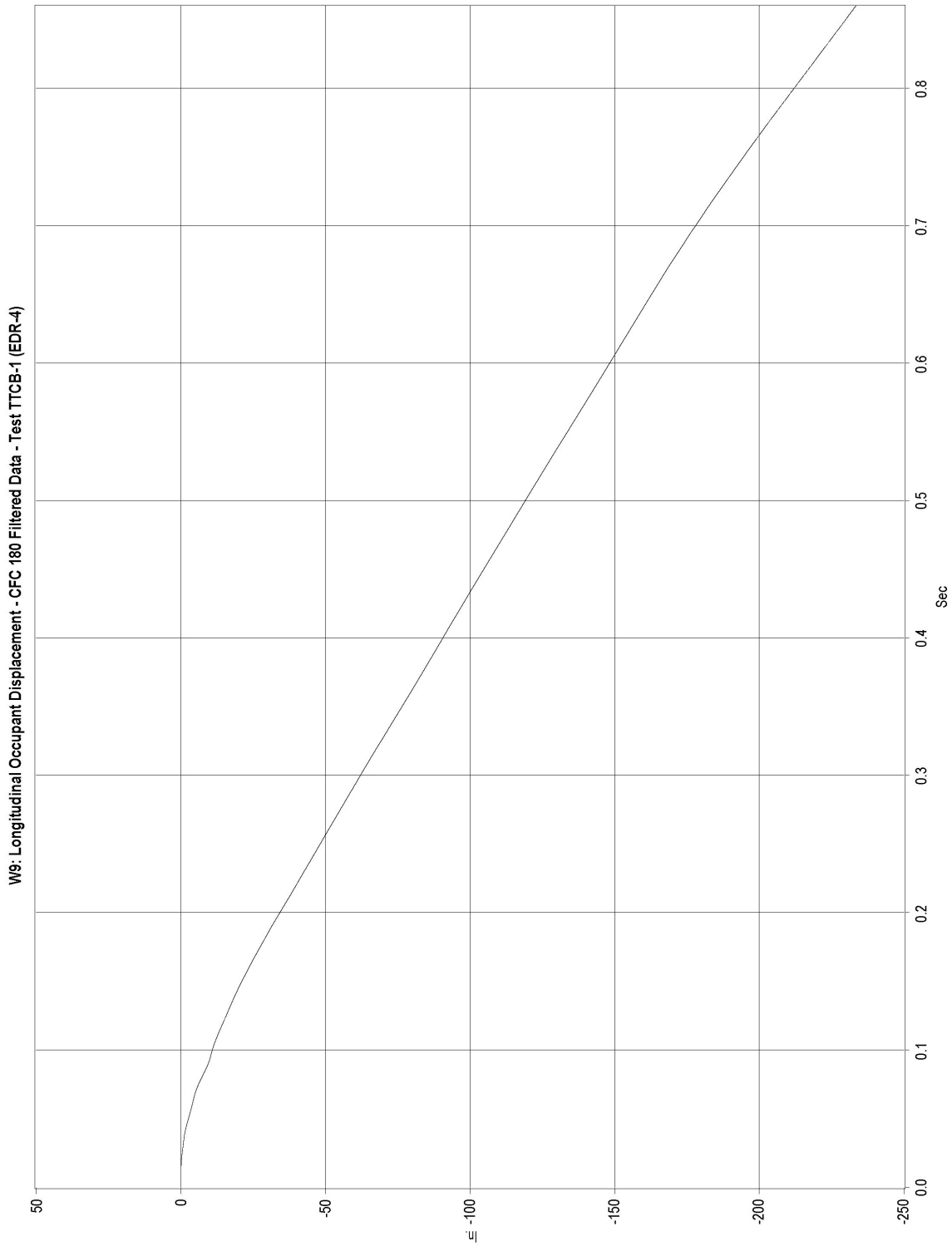

Figure E-9. Graph of Longitudinal Occupant Displacement (EDR-4), Test No. TTCB-1

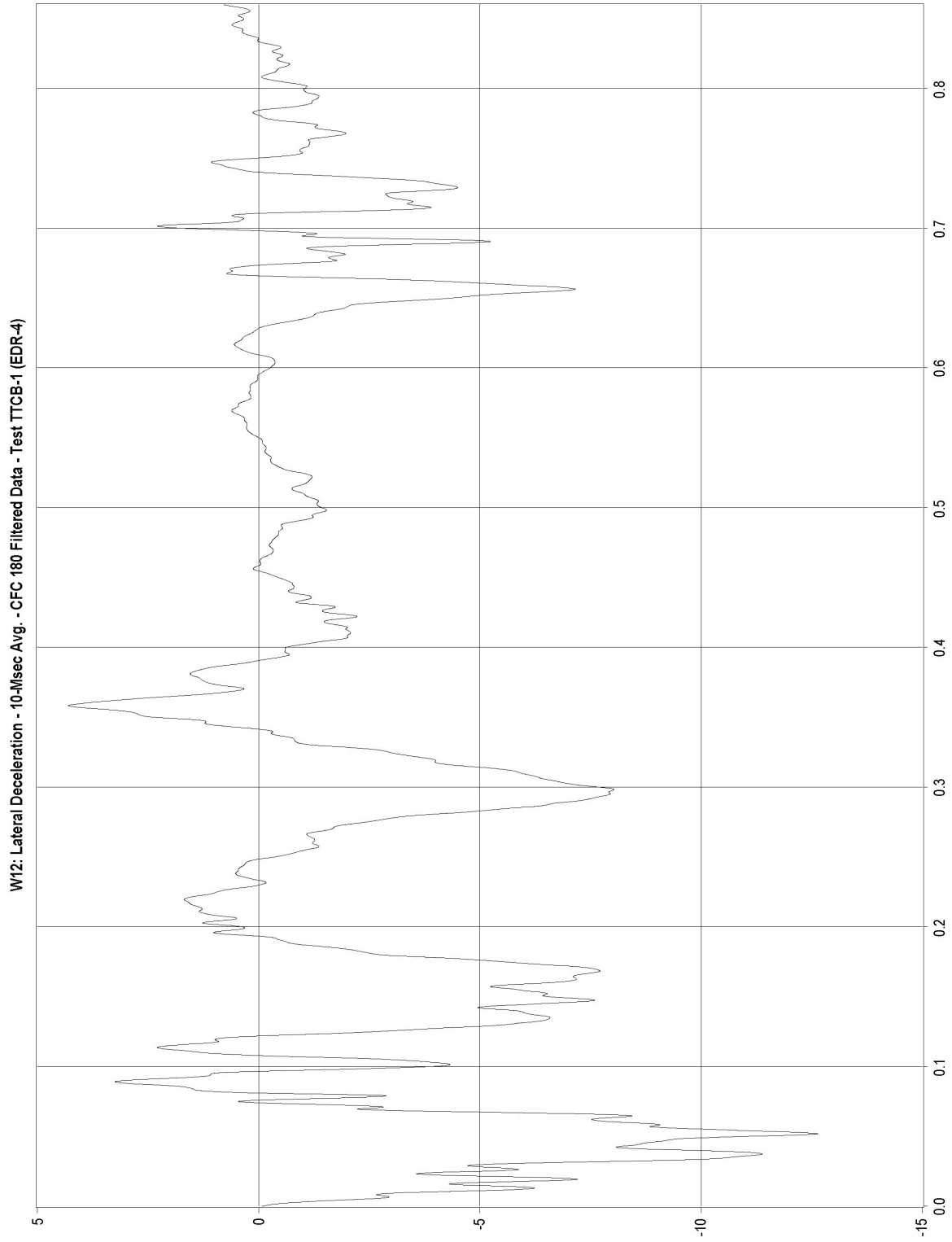

Figure E-10. Graph of 10 ms Average Lateral Deceleration (EDR-4), Test No. TTCB-1

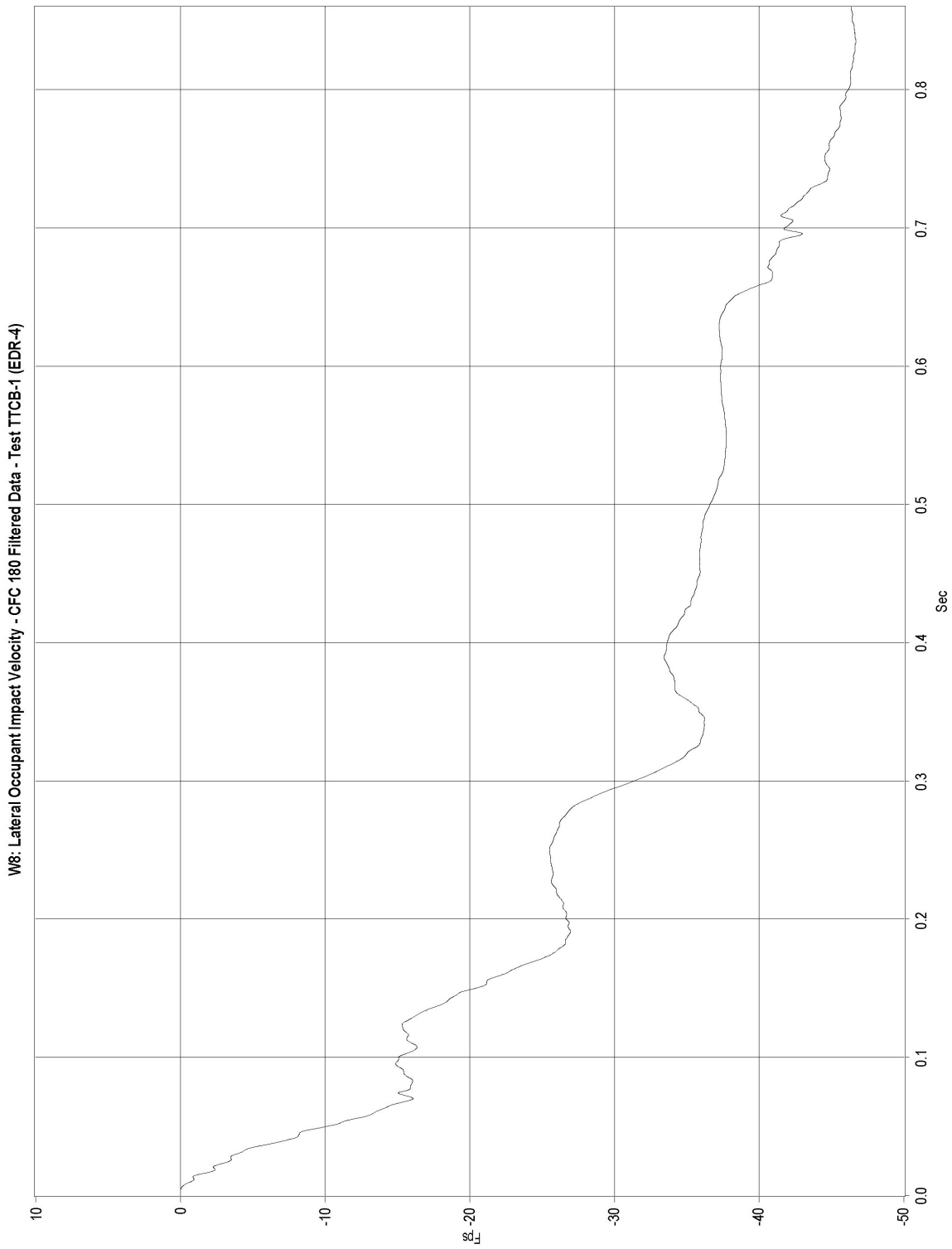

Figure E-11. Graph of Lateral Occupant Impact Velocity (EDR-4), Test No. TTCB-1

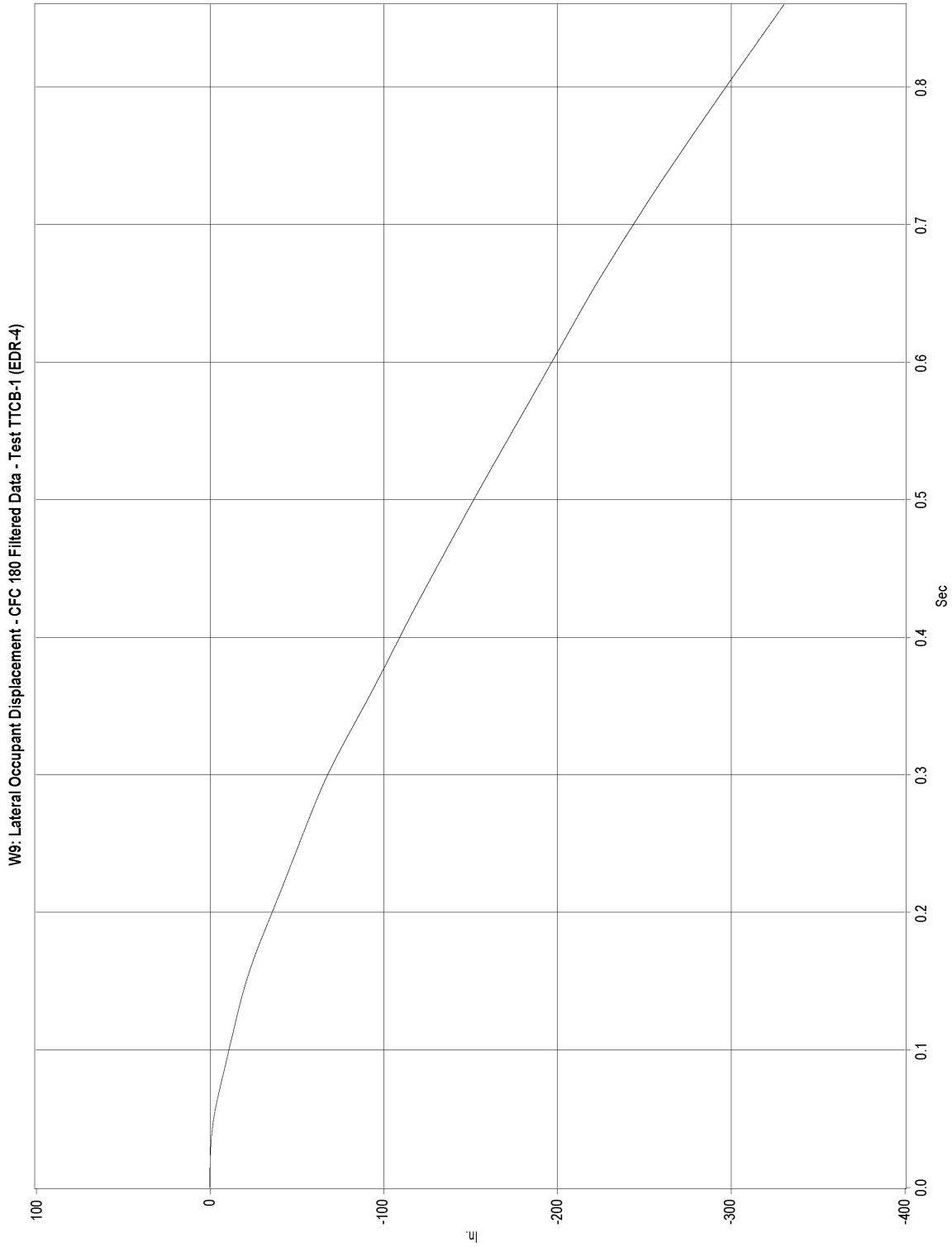

Figure E-12. Graph of Lateral Occupant Displacement (EDR-4), Test No. TTCB-1

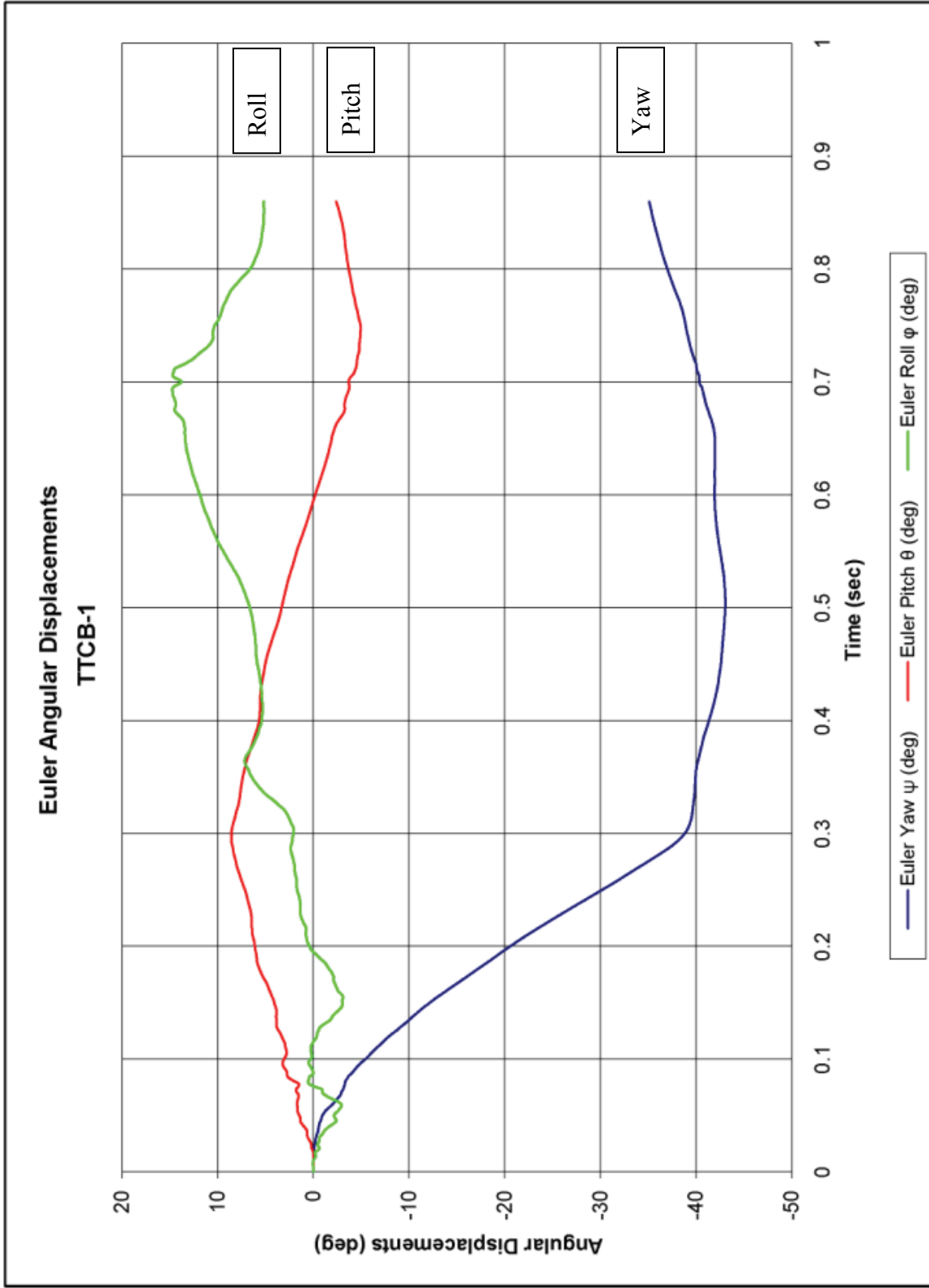

Figure E-13. Graph of Vehicle Roll, Pitch, and Yaw Angular Displacements, Test No. TTCB-1

APPENDIX F. String Pot Data

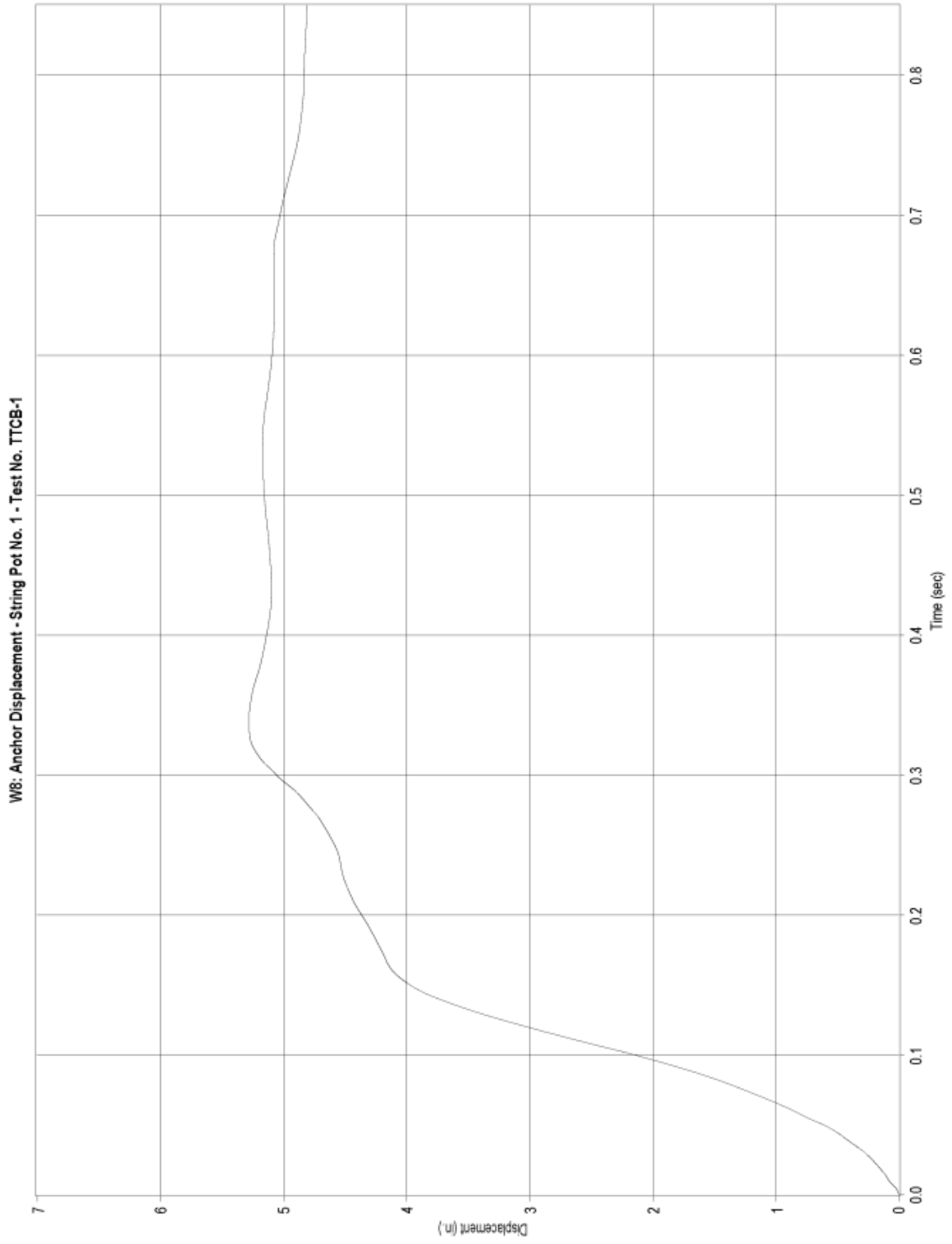

Figure F-1. String Potentiometer No. 1, Offset Anchor Data, Test No. TTCB-1

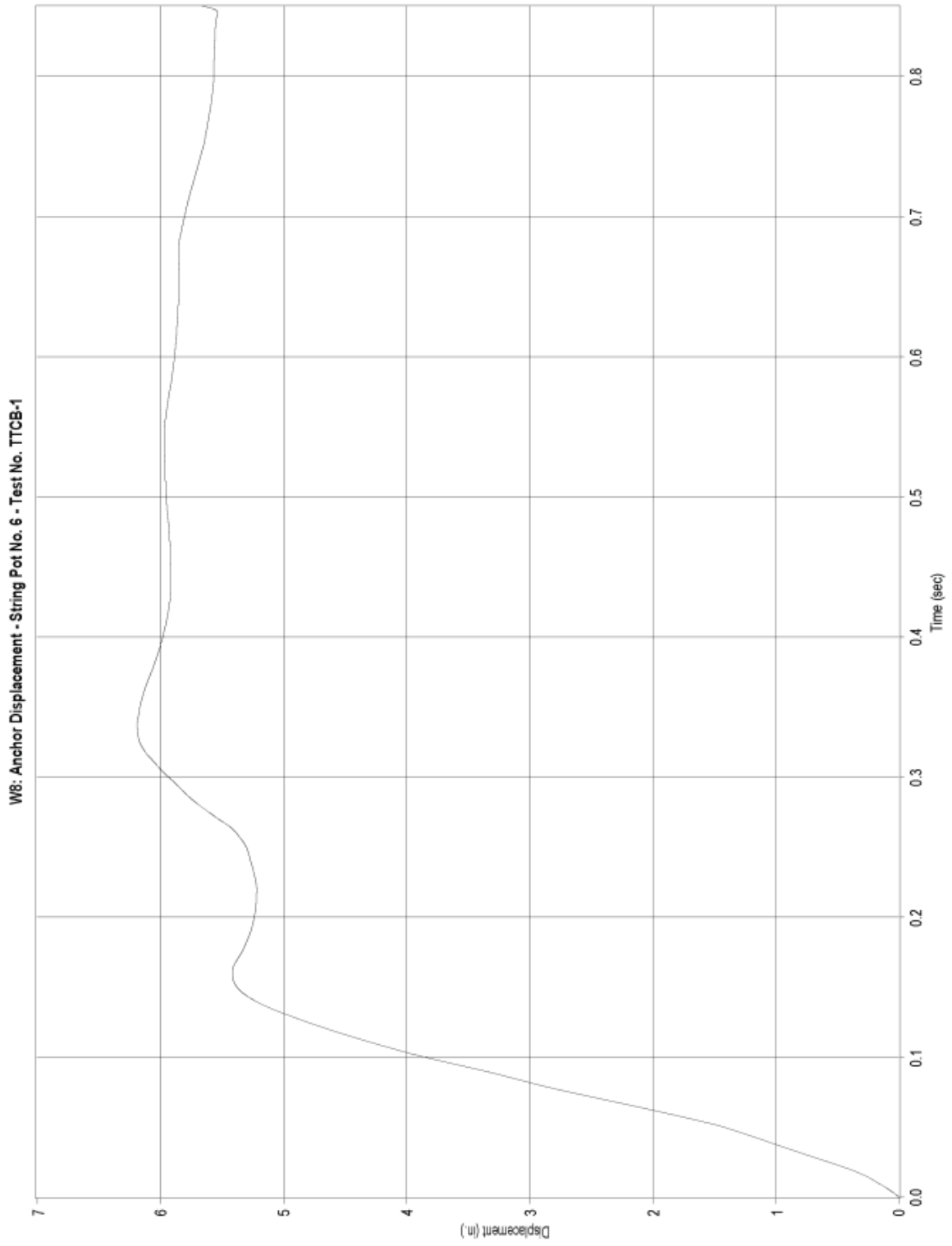

Figure F-2. String Potentiometer No. 6, Centerline Anchor Data, No. Test No. TTCB-1

END OF DOCUMENT