

12-2013

Implementation of Precast Concrete Deck System NUDECK (2nd Generation)

George Morcous

University of Nebraska-Lincoln, gmorcous2@unl.edu

Maheer K. Tadros

University of Nebraska - Lincoln, mtadros1@unl.edu

Follow this and additional works at: <http://digitalcommons.unl.edu/ndor>



Part of the [Transportation Engineering Commons](#)

Morcous, George and Tadros, Maheer K., "Implementation of Precast Concrete Deck System NUDECK (2nd Generation)" (2013).
Nebraska Department of Transportation Research Reports. 106.
<http://digitalcommons.unl.edu/ndor/106>

This Article is brought to you for free and open access by the Nebraska LTAP at DigitalCommons@University of Nebraska - Lincoln. It has been accepted for inclusion in Nebraska Department of Transportation Research Reports by an authorized administrator of DigitalCommons@University of Nebraska - Lincoln.

Implementation of Precast Concrete Deck System NUDECK (2nd Generation)

Nebraska Department of Roads (NDOR)

Project Number: SPR-P1 (13) M323



December 2013

Implementation of Precast Concrete Deck System NUDECK
(2nd Generation)

Nebraska Department of Roads (NDOR)

Project Number: SPR-P1 (13) M323

FINAL REPORT (Draft)

Principal Investigator

George Morcous and Maher K. Tadros

SPONSORED BY

Nebraska Department of Roads

December 2013

Technical Report Documentation Page

Report No.	Government Accession No.	Recipient's Catalog No.		
Title and Subtitle Implementation of Precast Concrete Deck System NUDECK (2 nd Generation)		1. Report Date December 2013		
		2. Performing Organization Code		
3. Author(s) George Morcous, Maher K. Tadros, and Afshin Hatami		4. Performing Organization Report No.		
5. Performing Organization Name and Address University of Nebraska-Lincoln 1110 South 67 th St. Omaha, Nebraska 68182-0178		6. Work Unit No.		
		7. Contract or Grant No.		
8. Sponsoring Agency Name and Address Nebraska Department of Roads Bridge Division P. O. Box 94759 Lincoln, NE 68509-4759		9. Type of Report and Period Covered Final Report		
		10. Sponsoring Agency Code		
11. Supplementary Notes				
12. Abstract The first generation of precast concrete deck system, NUDECK, developed by the University of Nebraska-Lincoln (UNL) for Nebraska Department of Roads (NDOR), was implemented on the Skyline Bridge, Omaha, NE in 2004. The project was highly successful and received two PCI Awards of Excellence. The second generation of precast concrete deck system NUDECK was developed recently to further simplify precast panel/girder production, speed up bridge superstructure construction, and improve deck durability. The second generation of NUDECK consists of full-width full-depth precast concrete deck panels that are 12 ft long to minimize the number of deck panels and transverse joints, and consequently accelerate bridge construction. It also uses covered individual pockets and bundled shear connectors at 4 ft spacing to simplify panel and girder production and eliminate the need for deck overlay. Precast deck panels are pre-tensioned in transverse direction and post-tensioned in the longitudinal to enhance deck durability to achieve the same service life of other bridge components. This report presents the first implementation of the second generation of NUDECK system to the Kearney East Bypass project in Kearney, NE. The project consist of twin bridges: the south bound bridge constructed using conventional cast-in-place deck; and the north bound bridge constructed using the 2 nd generation NUDECK system. Each bridge is a two-span continuous bridge that is 41 ft 8 in. wide and 332 ft long. Each span is 166 ft long and consists of five precast/prestressed concrete girders (NU1800) at 8 ft 6 in. spacing. This report presents the analysis, design, and detailing of the bridge superstructure. It also summarizes the experimental investigations conducted to evaluate the proposed design and construction details.				
13. Keywords: Precast Concrete, Deck Panels, Accelerated Bridge Construction, Prestressed Bridge Decks, Shear Connectors		14. Distribution Statement		
15. Security Classification (of this report) Unclassified	16. Security Classification (of this page) Unclassified	17. No. of Pages: 123	22. Price	

DISCLAIMER

The contents of this report reflect the views of the authors who are responsible for the facts and the accuracy of the data presented herein. The contents do not necessarily reflect the official views or policies of the Nebraska Department of Roads, nor of the University of Nebraska-Lincoln. This report does not constitute a standard, specification, or regulation. Trade or manufacturers' names, which may appear in this report, are cited only because they are considered essential to the objectives of the report. The United States (U.S.) government and the State of Nebraska do not endorse products or manufacturers.

ACKNOWLEDGEMENTS

This project was sponsored by Nebraska Department of Roads (NDOR) and University of Nebraska-Lincoln (UNL). The technical support of NDOR technical advisory committee (TAC) members is gratefully acknowledged. The donation of test specimens by Precast Concrete Association of Nebraska (PCAN) is highly appreciated. Also, the efforts of graduate students Peter Samir, Shaddi Assad, and Mohamed Elkady are acknowledged.

TABLE OF CONTENTS

Abstract	7
1. Introduction	8
1.1 Background	8
1.2 Problem Statement	8
1.3 Objectives	11
2. Project Description.....	12
3. Construction Sequence.....	15
4. Analysis, Design, and Detailing	27
5. Pullout Experimental Investigation.....	43
5.1 Girder Pullout Testing	43
5.2 Deck Pullout Testing	58
6 Full-Scale Experimental Investigation	72
6.1 Panel Lifting Testing	72
6.2 Composite Girder Flexure Testing	78
7 Conclusions.....	91
8 References	92
9 Appendices	93
9.1 Appendix A: Analysis Results	93
9.2 Appendix B: NDOR Project Plans	99
9.3 Appendix C: Specimen Fabrication	106
9.4 Appendix D: Specimen Testing	119

ABSTRACT

The first generation of precast concrete deck system, NUDECK, developed by the University of Nebraska-Lincoln (UNL) for Nebraska Department of Roads (NDOR), was implemented on the Skyline Bridge, Omaha, NE in 2004. The project was highly successful and received two PCI Awards of Excellence. The second generation of precast concrete deck system NUDECK was developed to further simplify precast panel/girder production, speed up bridge superstructure construction, and improve deck durability. The second generation of NUDECK consists of full-width full-depth precast concrete deck panels that are 12 ft long to minimize the number of deck panels and transverse joints, and consequently accelerate bridge construction. It also uses covered individual pockets and bundled shear connectors at 4 ft spacing to simplify panel and girder production and eliminate the need for deck overlay. Precast deck panels are pre-tensioned in transverse direction and post-tensioned in the longitudinal to enhance deck durability to achieve the same service life of other bridge components.

This report presents the first implementation of the second generation of NUDECK system to the Kearney East Bypass project in Kearney, NE. The project consist of twin bridges: the south bound bridge constructed using conventional cast-in-place deck; and the north bound bridge constructed using the 2nd generation NUDECK system. Each bridge is a two-span continuous bridge that is 41 ft 8 in. wide and 332 ft long. Each span is 166 ft long and consists of five precast/prestressed concrete girders (NU1800) at 8 ft 6 in. spacing. This report presents the analysis, design, and detailing of the bridge superstructure. It also summarizes the experimental investigations conducted to evaluate the proposed design and construction details.

1 INTRODUCTION

1.1 Background

Full-depth precast concrete deck systems have several advantages, such as improved construction quality, reduced construction time and impact on traveling public, possible weight reduction, and reduction of total project life-cycle cost. The quality of precast deck systems is superior to field-cast concrete bridge decks because production occurs in a controlled plant environment. The variability of construction due to environmental conditions is eliminated in the plant that uses consistent casting operations and curing techniques. Moreover, there is a major weakness of cast-in-place (CIP) decks for which a solution has not been found. When concrete is placed over relatively stiff girders, it becomes part of the girder/deck composite system as soon as it begins to harden—several hours after placement. At that time, its tensile capacity is small. Shrinkage in the first few hours after setting and the temperature drop as the heat of cement hydration dissipates causes a reduction in concrete volume that cannot be accommodated by the restraint of the supporting girders. This often results in cracking, especially in the transverse direction, that continues to develop with the concrete shrinkage, most of which occurs in the first 60 days of the concrete age. Shrinkage and cracking are eliminated by using precast deck panels¹.

The size of precast concrete deck panels is smaller than the full bridge deck, thereby reducing the mix, placing, and finishing variability that exists in the field. Also, because the panels are small, curing is easily controlled and applied immediately to achieve the best material performance characteristics. High performance concrete (HPC) is recommended for all bridge decks, due to carrying repeated load cycles in severe environmental conditions. Plant casting provides greater assurance that the performance characteristics of HPC will be achieved. For example, plant-produced 8,000 psi concrete panels are just as easily produced as 4,000 psi concrete panels, while a CIP concrete deck is hard to consistently produce at a strength higher than 4,000 or 5,000 psi. More important than strength in bridge decks, shrinkage and the associated cracking are greatly controlled. A two-way prestressed concrete deck is expected to be crack-free for the service life of the bridge, an advantage that is not practical to achieve on CIP decks. The construction method becomes more critical as available field labor decreases or labor turnover for contractors persists. Precast concrete deck panels can be designed as composite or non-composite with the supporting girders. A non-composite panel is less complicated and more cost efficient to fabricate. Elimination of the shear connectors simplifies forming the panel and reduces work during post-tensioning operations. This, however, requires that relatively large girders be used to carry traffic loads without aid from the deck as in composite systems. The more common composite system is structurally superior and overall is much more cost-effective².

1.2 Problem Statement

The first generation of precast concrete deck system, NUDECK, developed jointly by the University of Nebraska-Lincoln (UNL) and Nebraska Department of Roads (NDOR), was successfully implemented on the Skyline Bridge, Omaha, NE in 2004 as shown in Figure 1.1. The project was highly successful and received two PCI Awards of Excellence and as it resulted in very reasonable cost per square foot of the deck panels^{3,4}.

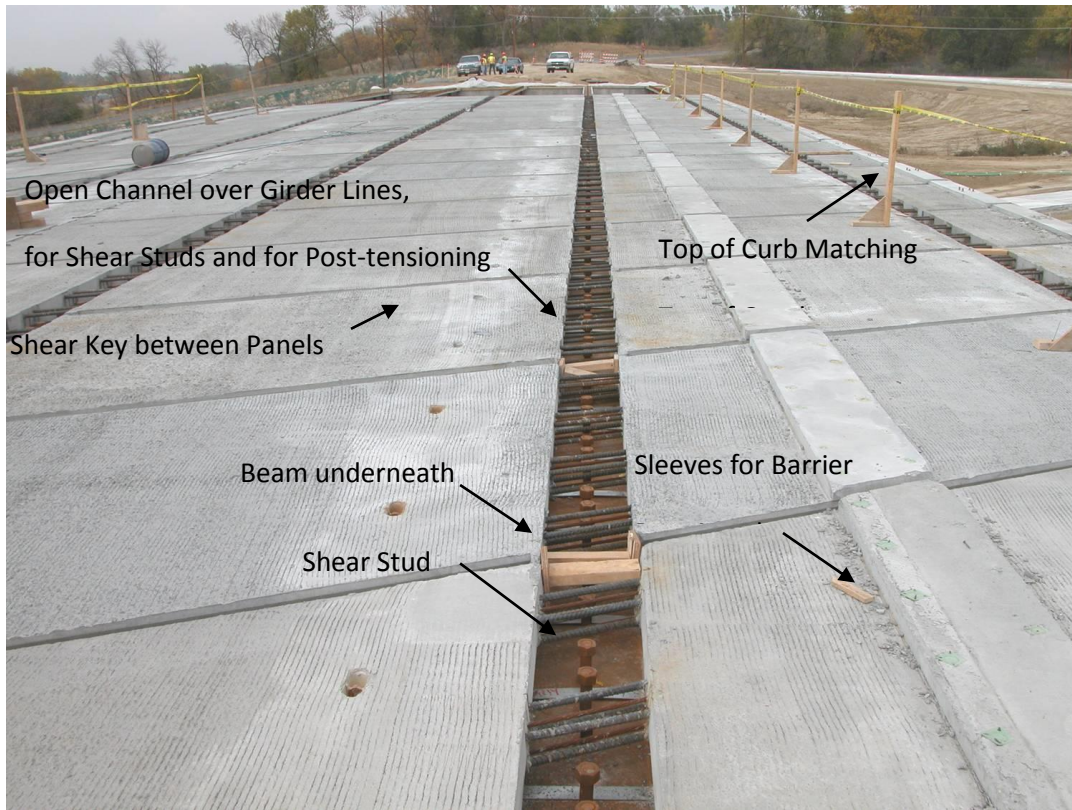

Figure 1.1: Precast Prestressed Concrete Deck Panels in Skyline Bridge (1st generation NUDECK)

The 1st generation of NUDECK system had several innovations such as:

- Panels are made of high performance concrete that is pre-compressed in two directions such that the residual stresses in service are compression and cracking is avoided.
- Most of the creep, shrinkage, and temperature change due to hydration took place before the panel is connected with the rigid underlying beams, eliminating most of cracking due to the restraining of stiff girders.
- The continuous gap over beam lines assures simple, high quality post-tensioning and eliminates the question about the quality of tendon grouting.
- Individual post-tensioning of strands allows most contractors, even in areas not familiar with post-tensioning, to do the post-tensioning work with local crews. The precasters also would have the option to include post-tensioning as part of supplying the panels.
- The proposed prestressed concrete deck panel system covers the entire width of a bridge, which eliminates the necessity of forming the overhangs.
- All materials used in the production of the deck panels are non-proprietary and readily available. This makes the system cost competitive with CIP concrete decks, while it is much more rapid to build and durable to maintain.
- Use of large diameter studs reduces the required number of studs. Thus, economy of fabricated steel beams is improved and, more importantly, worker safety is enhanced.
- Finally, the cast-in-place overlay allows for adjustments in roadway profile. It provides an excellent riding surface, and large cover for the reinforcement.

A number of lessons were learned from the construction of the Skyline Bridge, which were the motive for making further improvements that led to the development of the 2nd generation of NUDECK system^{5,6}. These lessons include:

- Threading post-tensioning strands through the end panels and between panel reinforcement, as shown in Figure 1.2, was a tedious and time-consuming operation. Laying down all post-tensioning strands on top of each girder prior to placement of deck panels would have significantly simplified this operation.
- Frequent conflicts occurred between the deck reinforcement (strands and bars) and the shear studs welded to the girder at the open channel locations as shown in Figure 1.2. Larger spacing between shear connectors as well as bundling them would have eliminated this issue.
- Overlay required seven days to cure, which is a major disadvantage to rapid construction and is expensive. In addition to the use of type k-cement, which was not locally available, to minimize overlay shrinkage. Eliminating the need for deck overlay would have resulted in significant time and cost savings.
- The use of 8 ft wide panels resulted in large number of panels to fabricate, transport, and erect, in addition to the large number of transverse joints. Increasing panel width from 8 ft to 12 ft would significantly speed up construction and reduce number of transverse joints.
- The use of non-reinforced wet transverse joints, bent plates to form the haunch, and individual strand post-tensioning were very simple and successful operations to fabricators and contractors and should be used.



Figure 1.2: Threading post-tensioning strands (left) and conflicts between deck reinforcement and shear connectors (right)

1.3 Objective

To develop and implement the 2nd generation of precast concrete deck system (NUDECK) that has the following features:

- Easy to fabricate full-width full-depth precast concrete deck panels that are 12 ft long to minimize the number of panels and cast-in-place transverse joints.
- Individual shear connectors at 4 ft spacing to simplify girder production and minimize conflicts during panel erection.
- Covered individual shear pockets at 4 ft spacing to eliminate the need for deck overlay and simplify panel production.
- Lifting inserts are located at the shear pockets to minimize panel penetrations.
- Two-way prestressing (transverse pre-tensioning and longitudinal post-tensioning) to control cracking and increase the service life of the deck.
- Post-tensioning strands located underneath the deck to eliminate threading strands through deck reinforcement or embedded ducts, which simplifies the construction.

2 PROJECT DESCRIPTION

The 2nd generation precast concrete deck system (NUDECK) will be implemented in the construction of the bridge/viaduct shown in Figure 2.1. This bridge is a part of Phase II of a three-phase project known as Kearney Easy Bypass, which is a relocation of Highway 10 in Buffalo County. Figure 2.1 shows the beginning and end of the Phase II project, which is scheduled for construction in 2014 and 2015. The bridge connects 11th street to the 56th street over the US-30 and Union Pacific Rail Road.

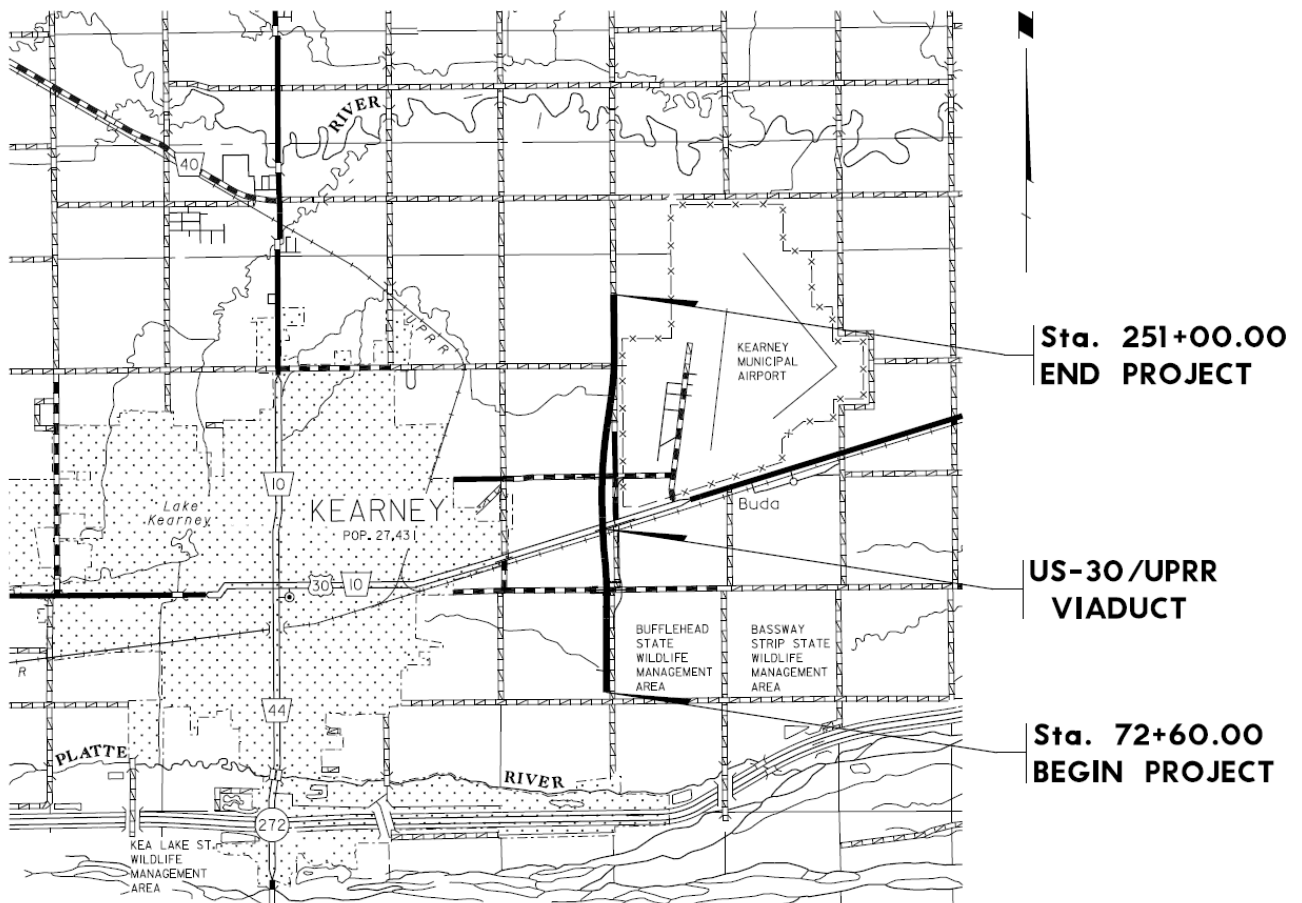

Figure 2.1: Map of project location

The project consist of twin bridges as shown in Figure 2.2: the south bound bridge will be constructed using conventional cast-in-place deck; and the north bound bridge will be constructed using the 2nd generation NUDECK system. Each bridge is a two-span continuous bridge that is 41 ft 8 in. wide and 332 ft long. Each span is 166 ft long and consists of five precast/prestressed concrete girders (NU1800) at 8 ft 6 in. spacing as shown in Figure 2.3. Each bridge has a 14° skew and 2% cross slope.

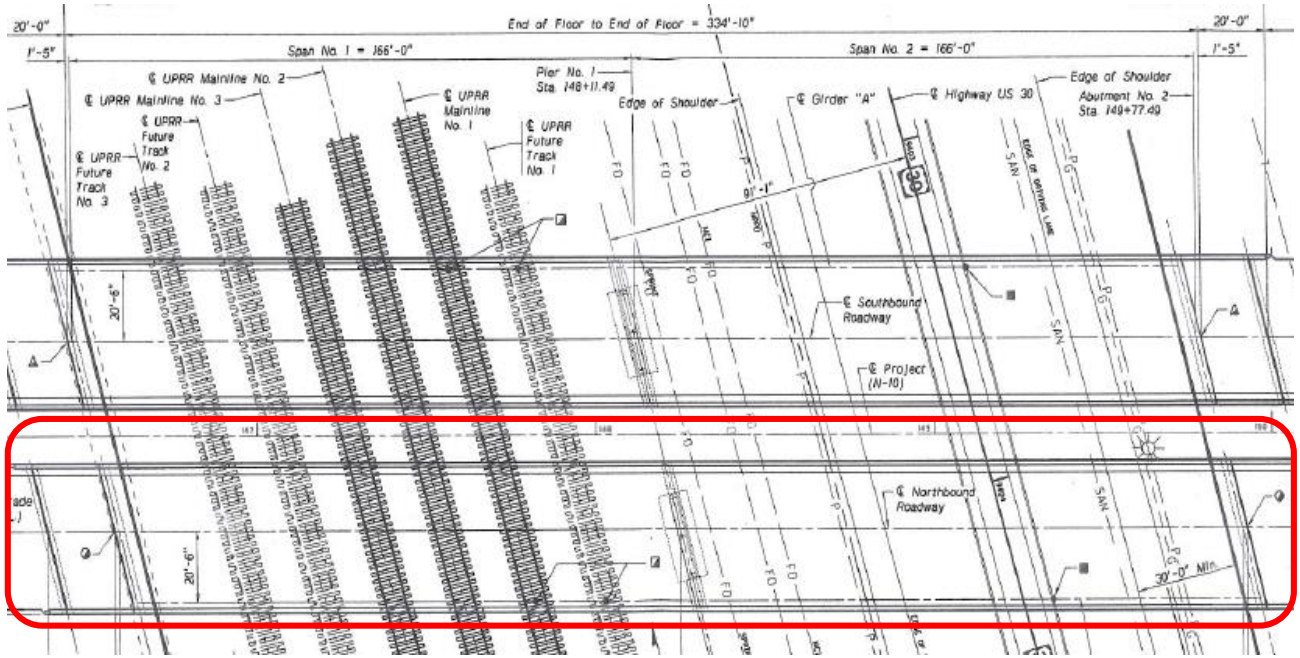

Figure 2.2: Twin bridge plan view

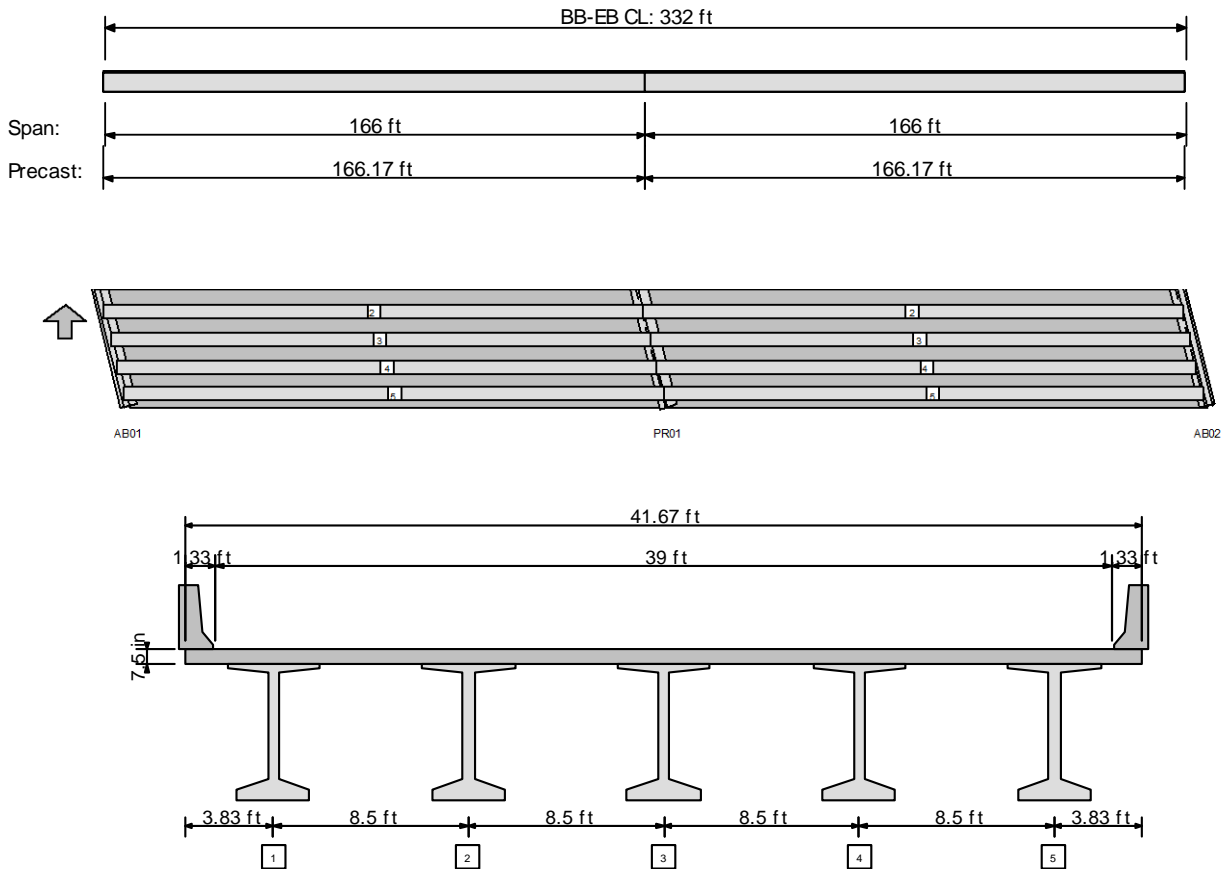

Figure 2.3: Bridge elevation, plan, and cross section

In order to describe the differences between the 1st and 2nd generations of NUDECK systems, the features of the two implementation projects are presented side by side in Table 2.1. This table summarizes the features of Skyline and Kearney East Bypass bridge project that are relevant to deck construction. Shaded rows highlights the most significant differences between the two generations, which are:

- Panel width
- Deck overlay
- Location of post-tensioning strands
- Shear connectors
- Panel-to-girder connection

Table 2.1: Comparison of 1st and 2nd generation of precast concrete deck systems (NUDECK)

Item	1 st Generation NUDECK	2 nd Generation NUDECK
Bridge Project	Skyline Bridge, Omaha, NE	Kearney East Bypass, Kearney, NE
Year Built	2003	2014
Spans (ft)	89, 125	166, 166
Width (ft)	51.5	41.67
Skew (deg.)	25	14
Girders	55 in. deep Steel Girders	NU1800 Concrete Girders
Girder Spacing (ft)	10.83	8.5
Panel Width (ft)	8	12
Panel Thickness (in)	6	7.5" + 0.5"
Overlay	2 in. Type K Cement	None
Concrete Strength (psi)	f'ci = 4,300; f'c = 6,000	f'ci = 3,500; f'c = 6,000
Transverse Pretension	8 - 0.5" Strands in two layers @24"	6 - 0.6" top layer & 6 - 0.5" in bottom layer @24"
Longitudinal Post-tension	16 - 0.6" Strands	12 - 0.6" Strands
Location of PT Strands	At panel mid height	Below deck panel
Crown and Cross Slope	Crown and 2% Cross Slope	No Crown, 2% Cross Slope
Transverse Joint	Wet Joint	Wet Joint
Rail	CIP and inserts in the precast panel	CIP with reinforcement extended from deck panels
Haunch Forms	Continuous Steel Bent Plate	Continuous Steel Bent Plate
Longitudinal Reinforcement	2#5 @ 12"	2#5 @ 12"
Transverse Reinforcement	8#7 Continuous bars (bot), 8#7 short bars (top)	2#5 @ 24"
Shear Studs	1-1/4" Diameter Studs @ 6"	Two 1-1/4" Diameter Grade 120 TR @ 48"
Panel-Girder Connection	12" Wide Open Continuous Channel filled with conventional concrete	8" x 16" x 5-1/2" covered individual pockets filled with self-consolidated concrete

For more detailed information about the project, please refer to the project plans available at NDOR web site <http://www.transportation.nebraska.gov/projects/kearney-east/index.htm>

3 CONSTRUCTION SEQUENCE

The construction sequence of the 2nd generation NUDECK precast concrete deck panels for the Kearney East Bypass project is presented in details in the following twenty steps. These steps are presented using the 3D sketches presented in Figure 3.1, which are numbered to correspond to each step. Also, a 3D animation of the construction sequence can be viewed in YouTube using the following link: http://www.youtube.com/watch?v=FOqcmkik_4Y

- 1- Fabricate 10 precast prestressed concrete NU1800 bridge girders using the approved mixture.
- 2- Fabricate 28 full-depth full-width precast prestressed concrete deck panels (26 typical panels and 2 end panels) using approved mixture.
- 3- Erect all the 10 girders (five girders per span) using the provided lifting points. Do not use the shear connectors or deviators in handling the girder. It is highly recommended that the alignment of shear connectors is checked using a steel template that was used earlier in panel and girder fabrication to ensure that shear connectors in all girder lines match the shear pockets in all precast deck panels within the allowed tolerance.
- 4- Form, reinforce, and pour the two end diaphragms and the pier diaphragm up to the level of the girder top flange using the approved mixture and after applying bond breaker to the embedded girder faces.
- 5- Conduct shim shots every 6 ft on the edges and center of each girder line to determine the actual profile of the cambered girders prior to deck placement.
- 6- Attach the deck support system, made of bent plates/angles, by welding them to the girder metal tabs to achieve the desired deck elevation and a minimum 2.5 in. thick haunch.
- 7- Attach extruded polystyrene panels to the diaphragm concrete between girders using approved adhesive to fill the gap between the deck panels and diaphragm concrete between girders.
- 8- Adjust the height of shear connectors by cranking them up to get $5 \pm 1/8$ in. embedment in the deck.
- 9- Attach compressible material to the top of the deck support system to eliminate any gaps between the deck soffit and the deck support system.
- 10- Lay down 12-0.6 in. diameter post-tensioning strands on top of each girder for the full length of the bridge and thread them through the corresponding openings in the end deviators.

- 11- Lay down 10#8 negative reinforcement bars on the top flange of each girder over the intermediate support. Bars should be staggered and supported using chairs to avoid conflict with strands.
- 12- Lift each deck panel using the specified eight lifting points located at pocket type A and place it on the deck support system.
- 13- Use backer rod to fill the gaps between adjacent deck panels and clean and moist the joint surfaces.
- 14- Pour flowable concrete/grout in the transverse joints between deck panels using an approved mixture.
- 15- Raise post-tensioning strands at the ends of each girder line to the mid-height of the deck and thread them through the holes of the anchor plates which are supported on the anchor block.
- 16- Weld bulkhead plates and tension individual post-tensioning strands using mono-strand jack starting from the middle and moving symmetrically outward. Repeat this process for each girder line starting from the middle one and moving symmetrically outward.
- 17- Pour/Pump the specified self-consolidating concrete (SCC) to fill the gap between the deck soffit and girder as well as shear pockets using the provided ports from the top of the deck. Moist girder top flange prior to pouring the SCC. Pouring should continue until the concrete overflow from the provided vents.
- 18- Form, reinforce, and pour approach slabs as well as the area around post-tensioning blocks in the deck
- 19- Form, reinforce and pour the rails.
- 20- Grind the top surface of the finished deck up ½ in. to ensure a leveled riding surface.

1

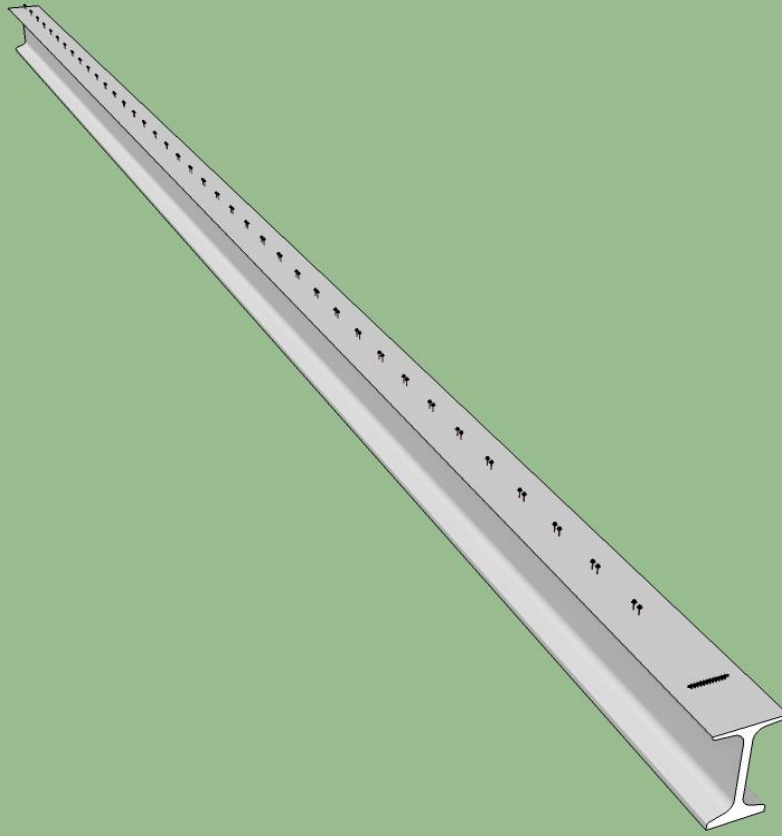

2

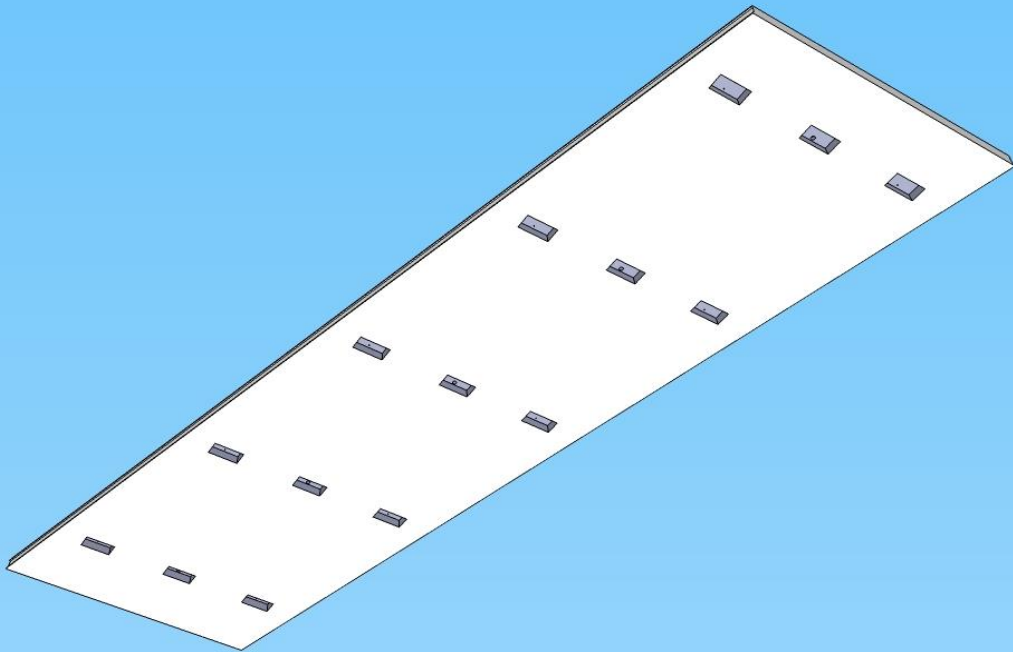

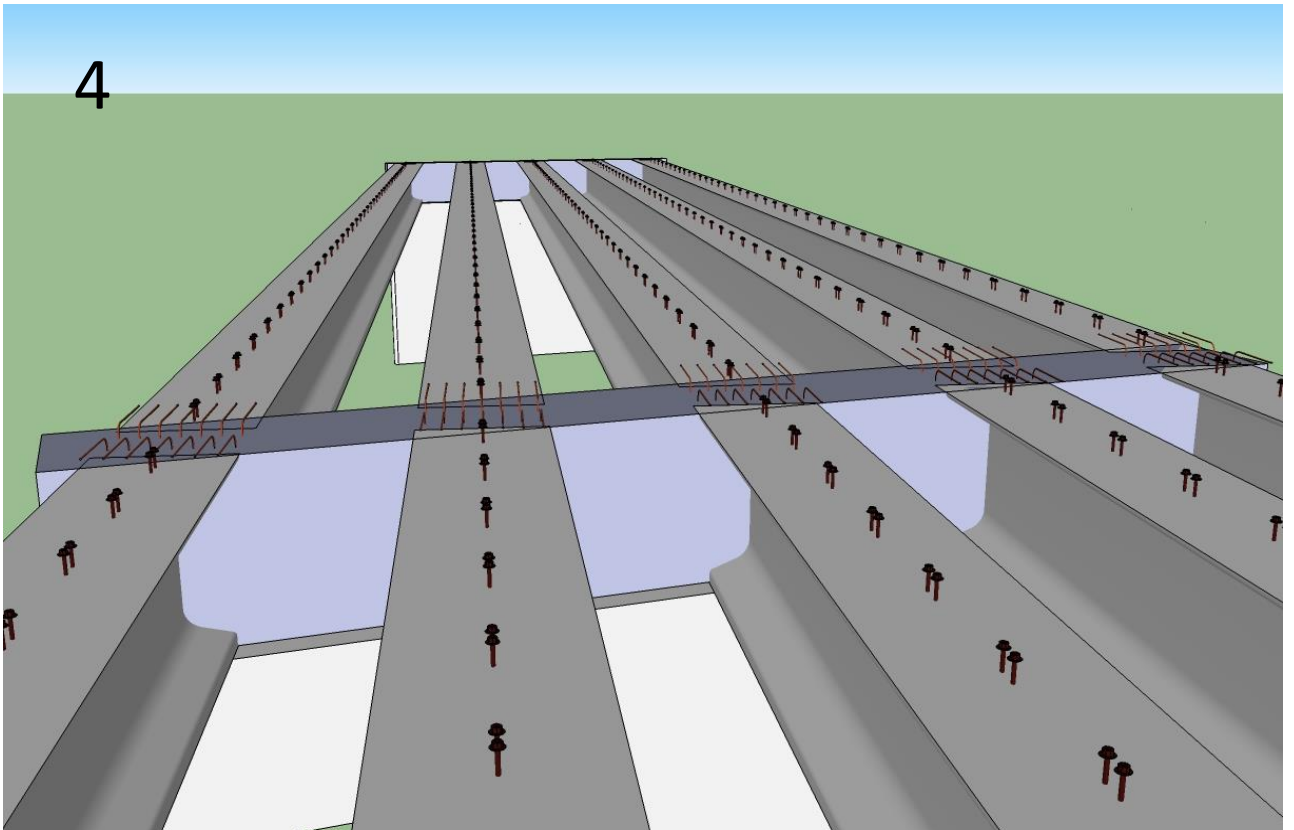
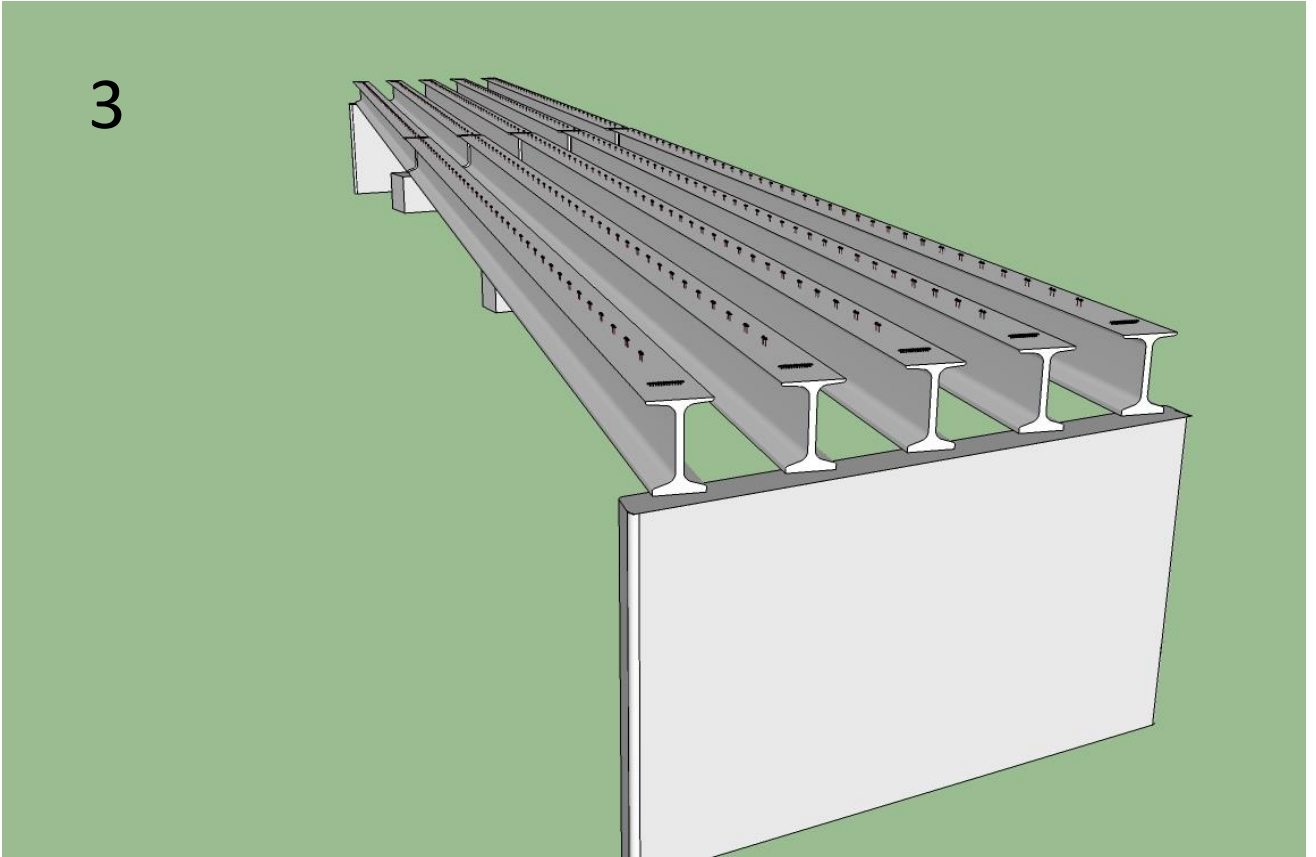

5

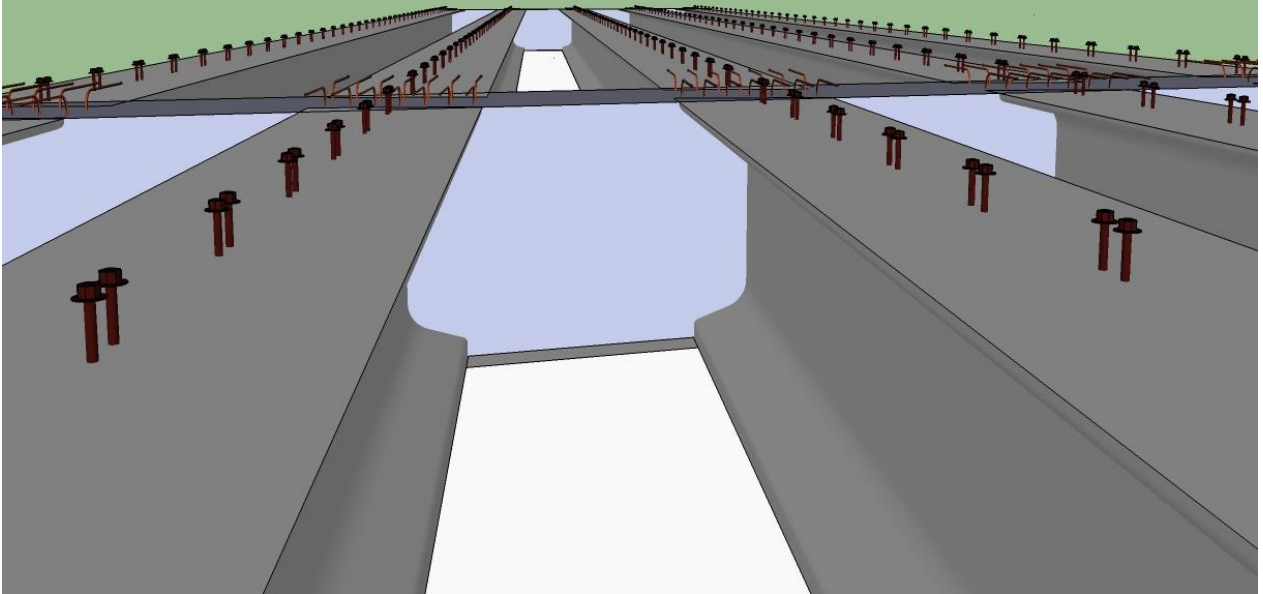

6

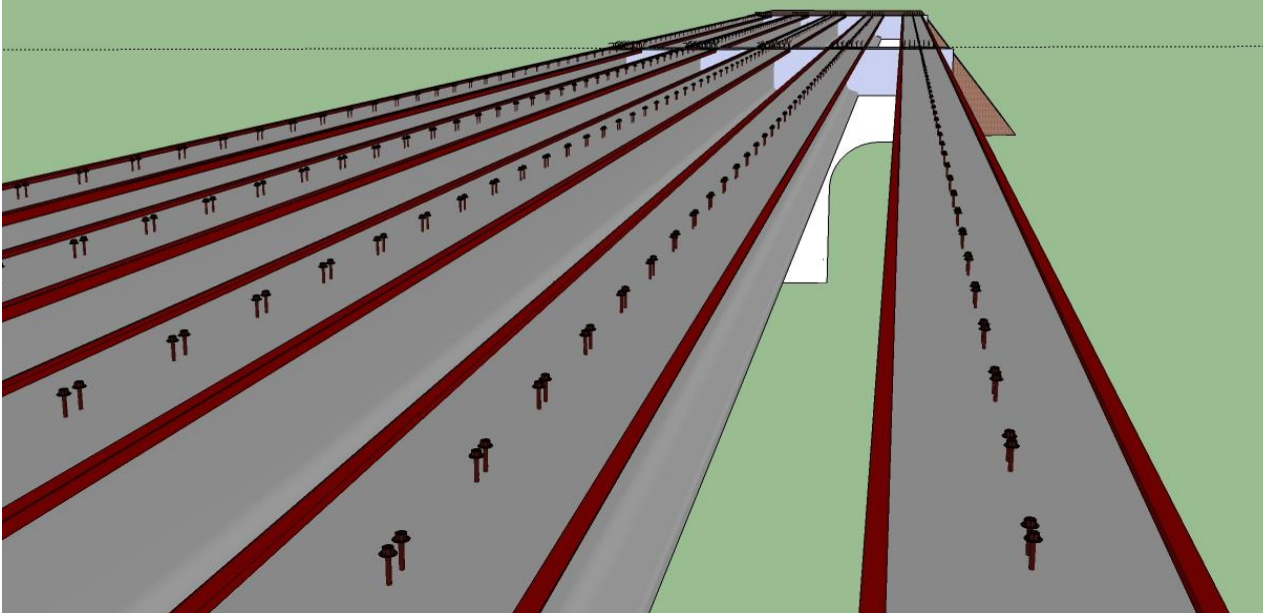

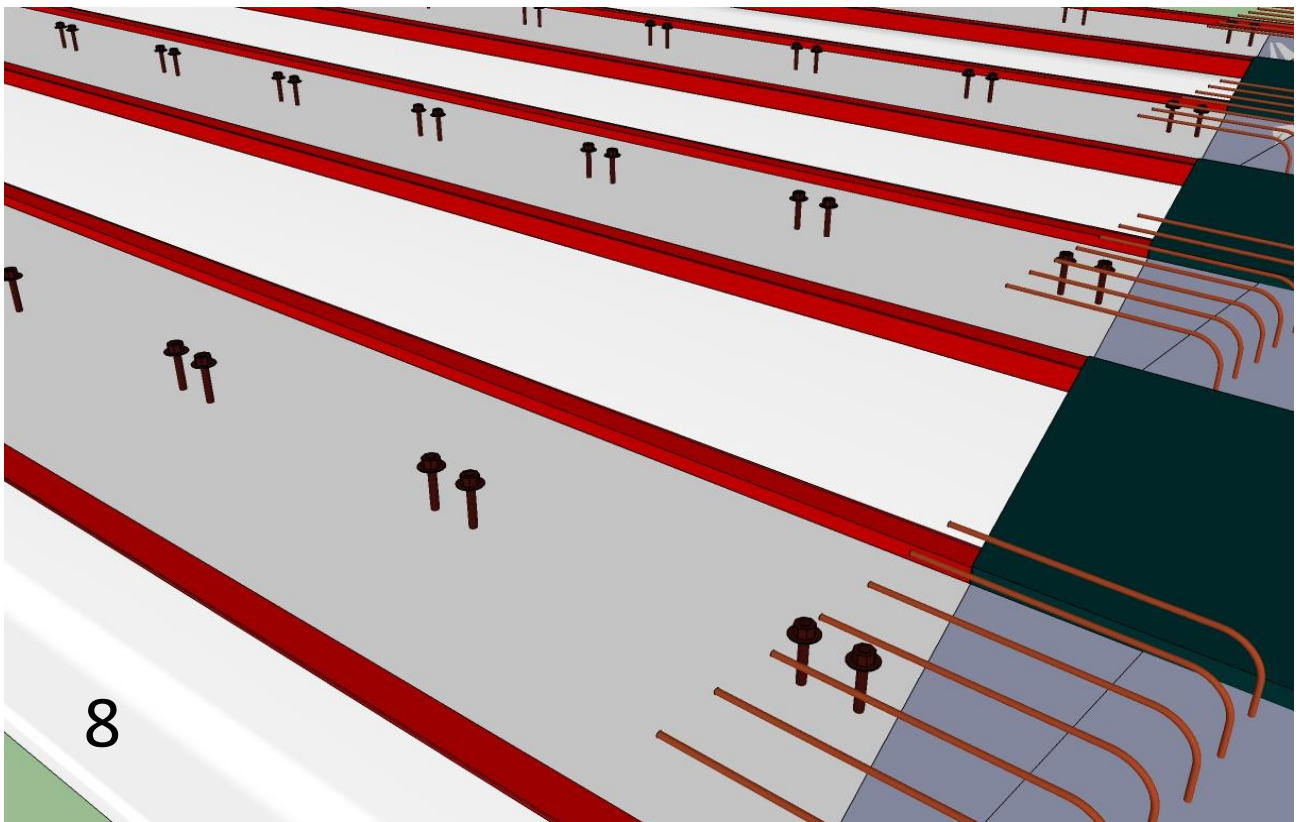
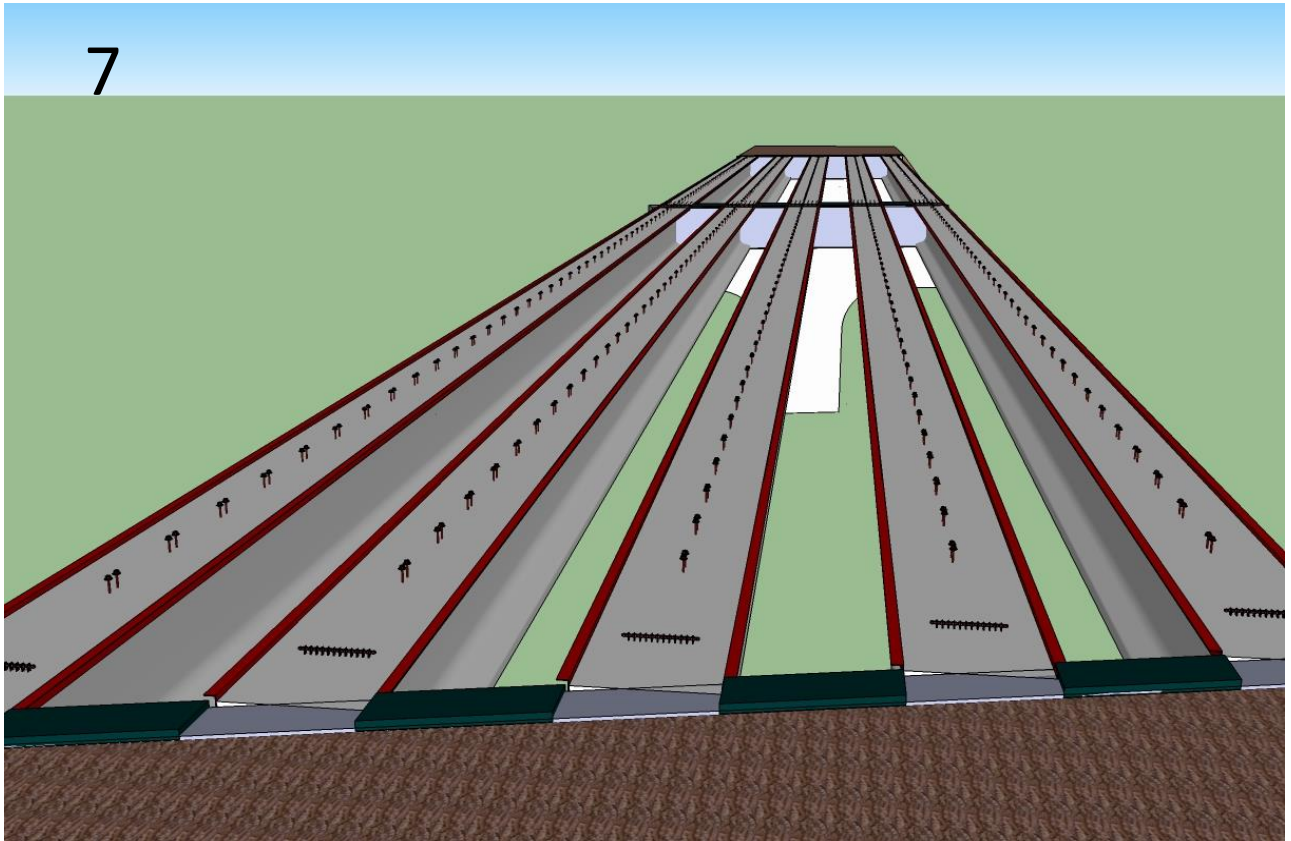

9

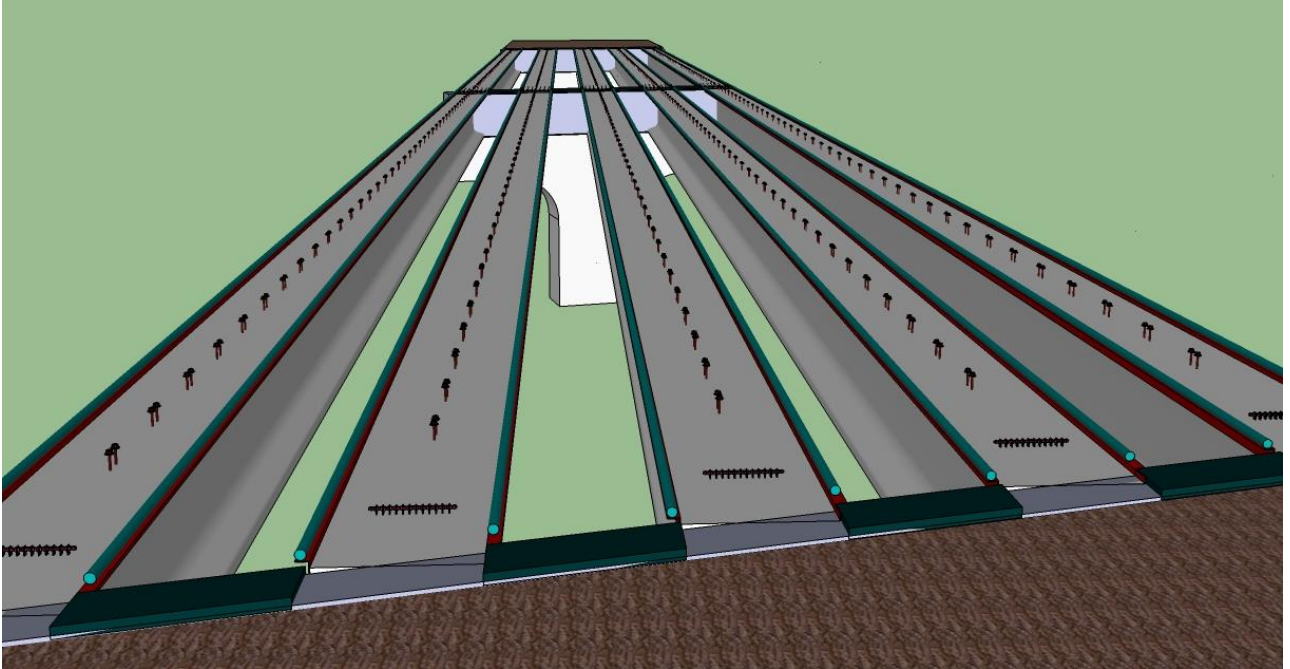

10

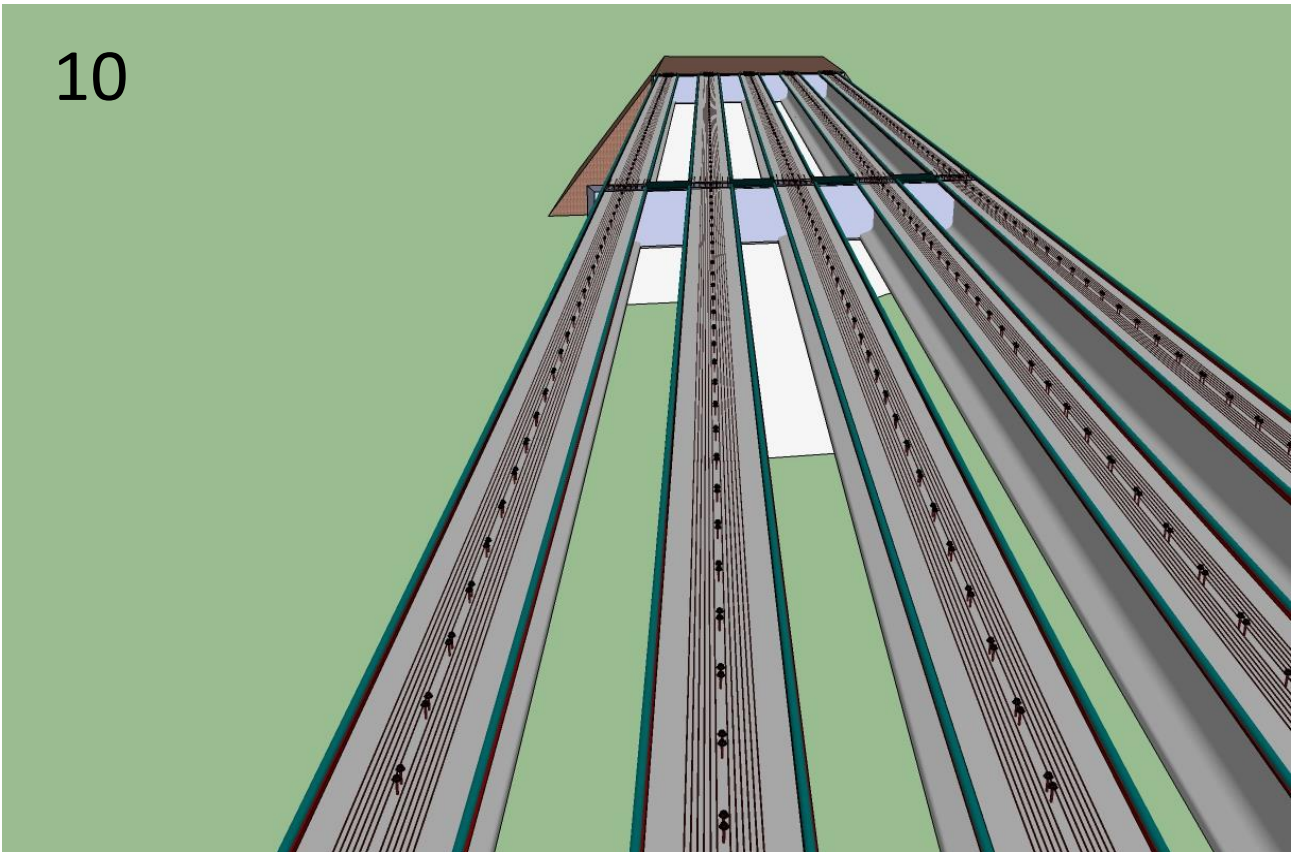

13

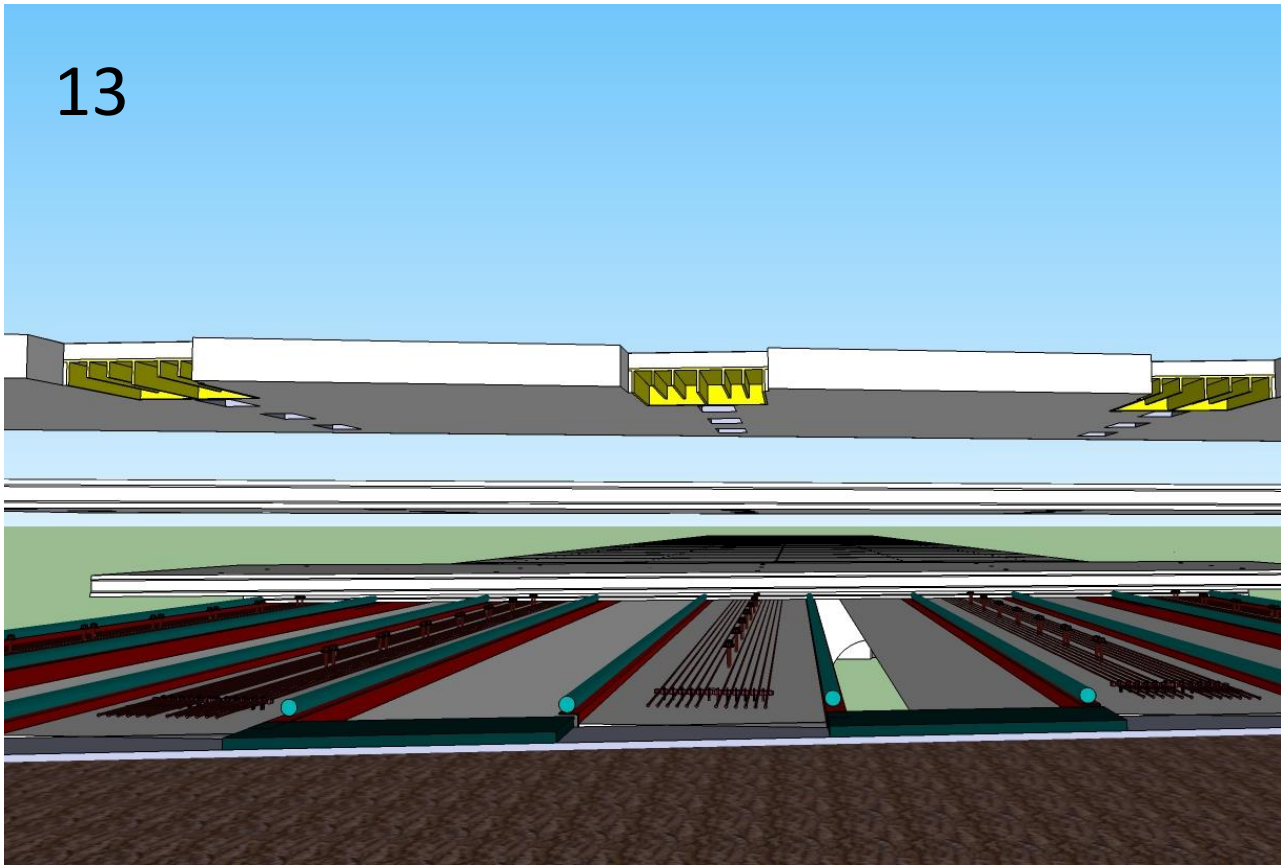

14

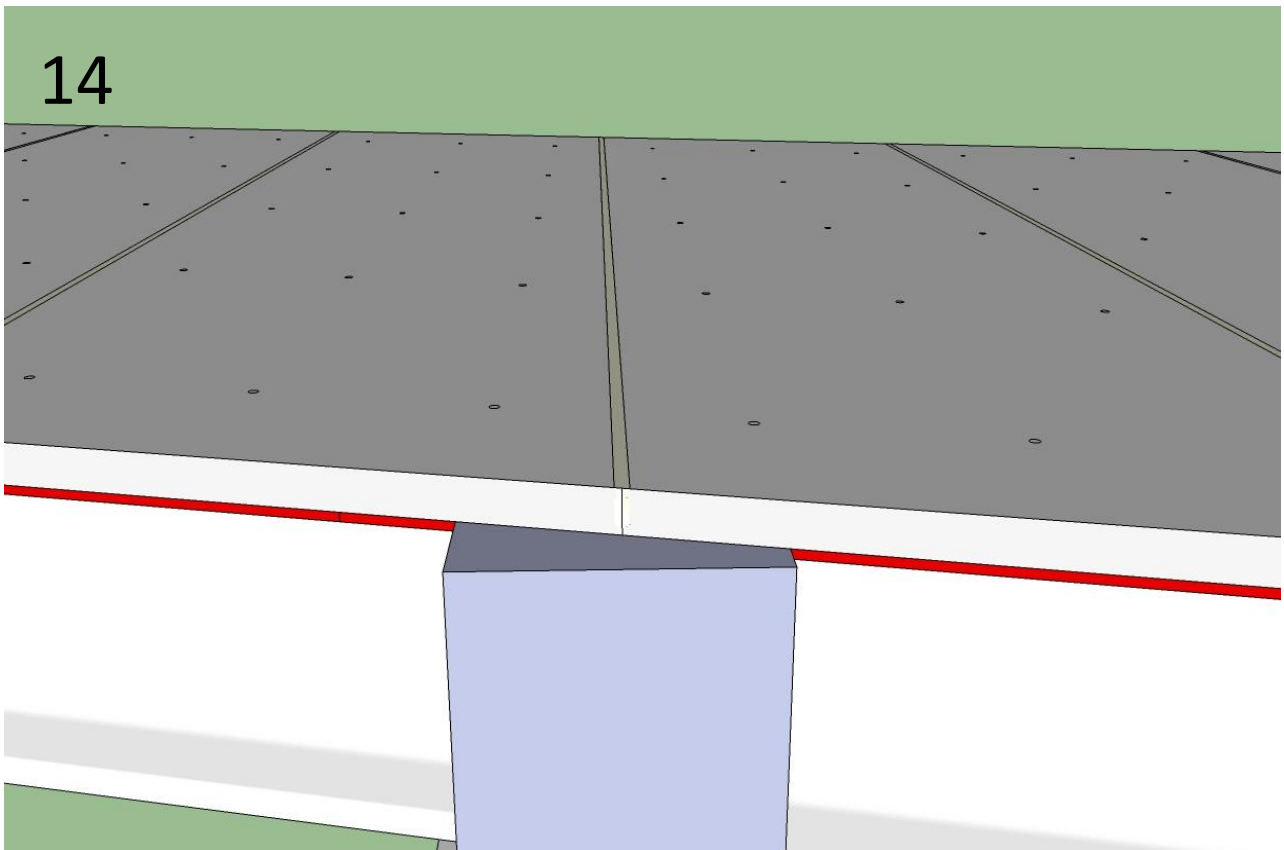

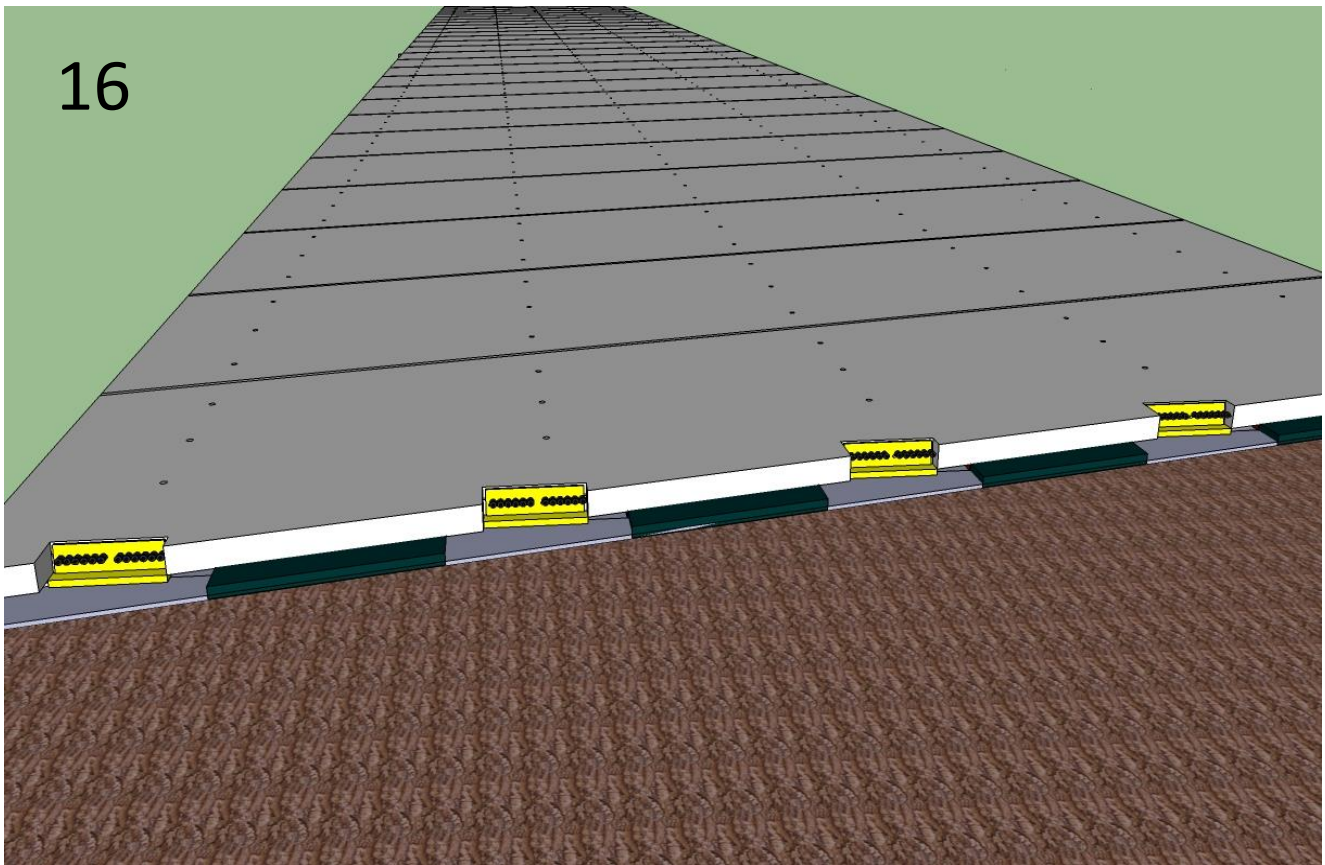
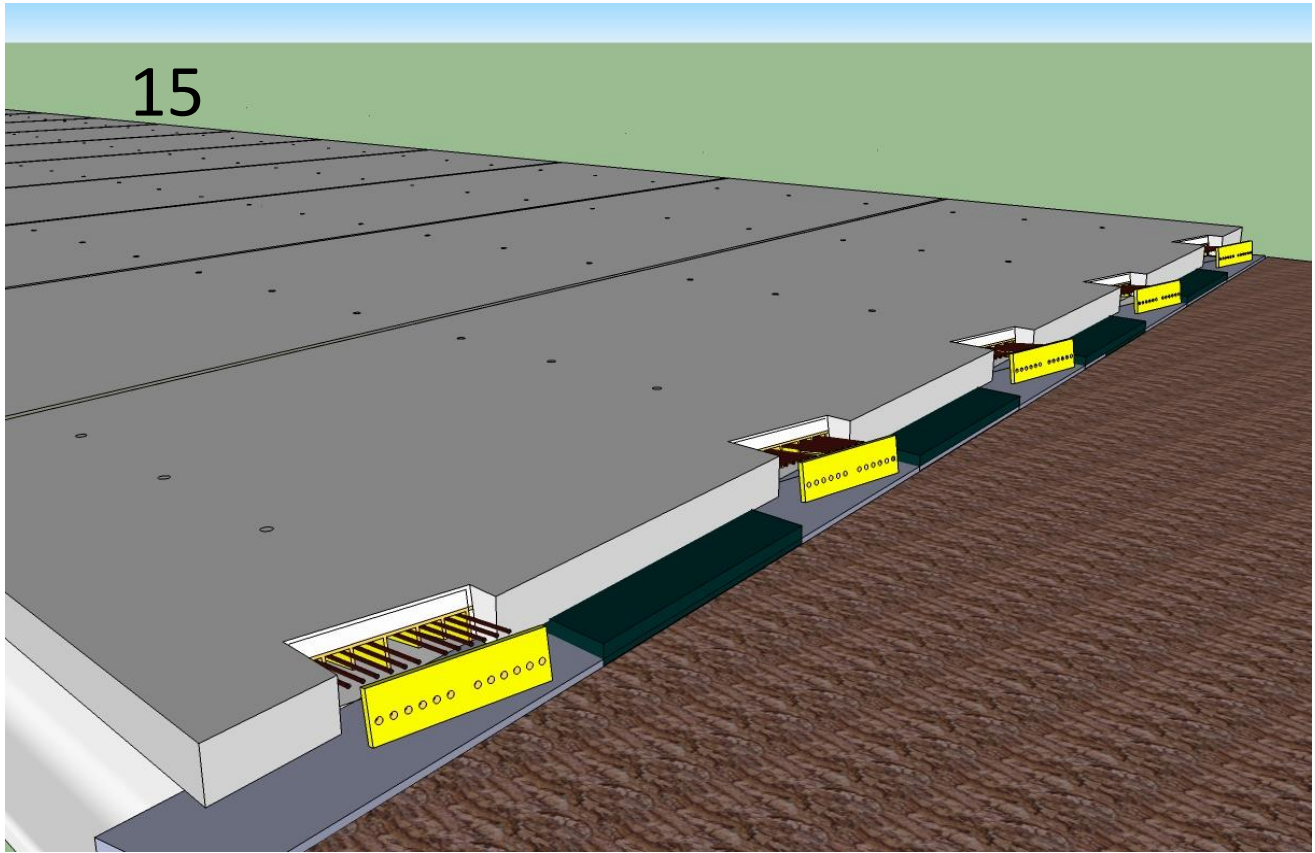

17

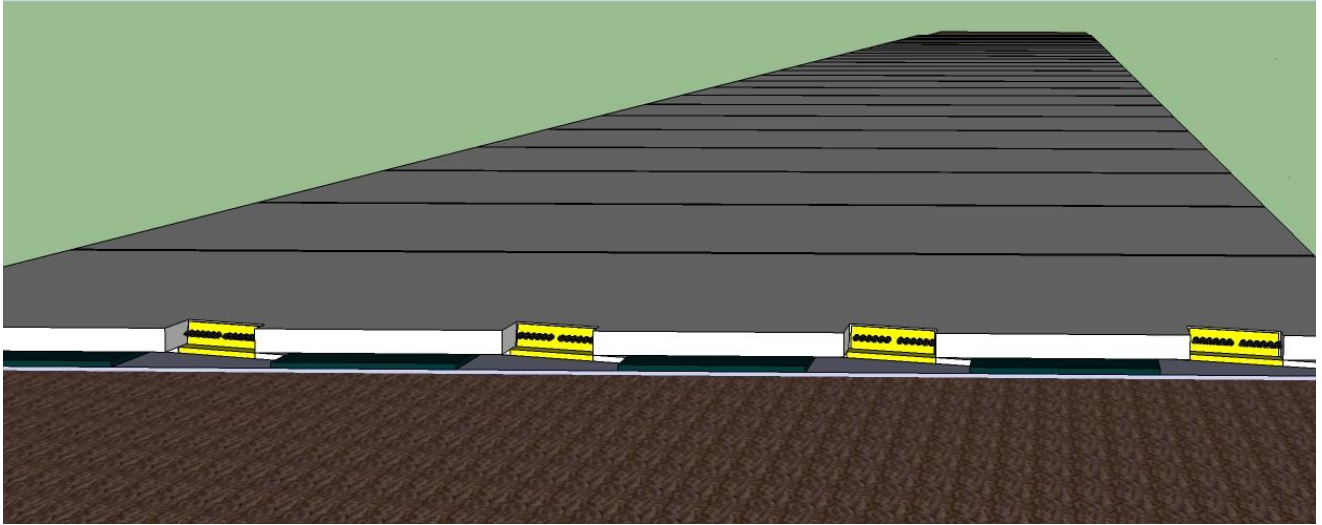

18

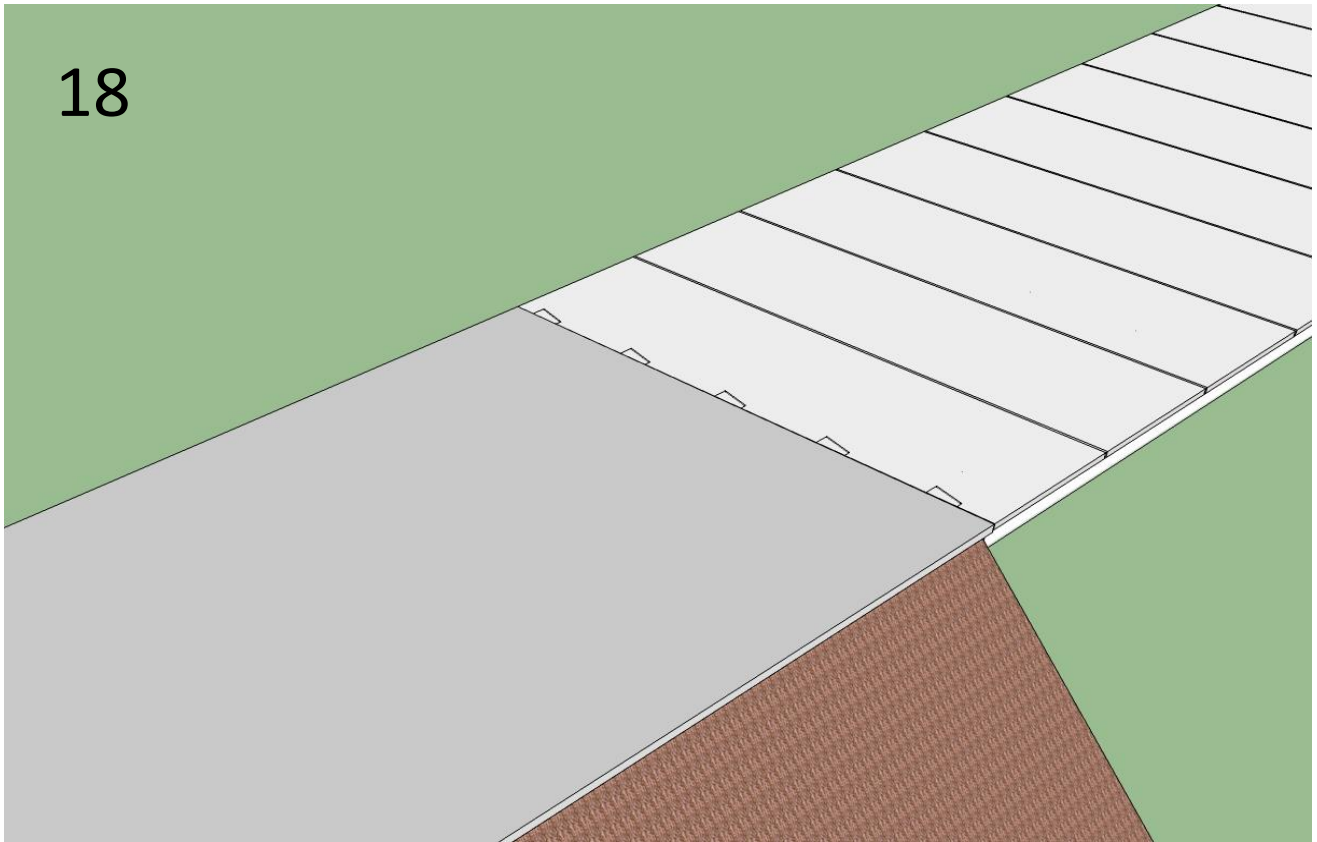

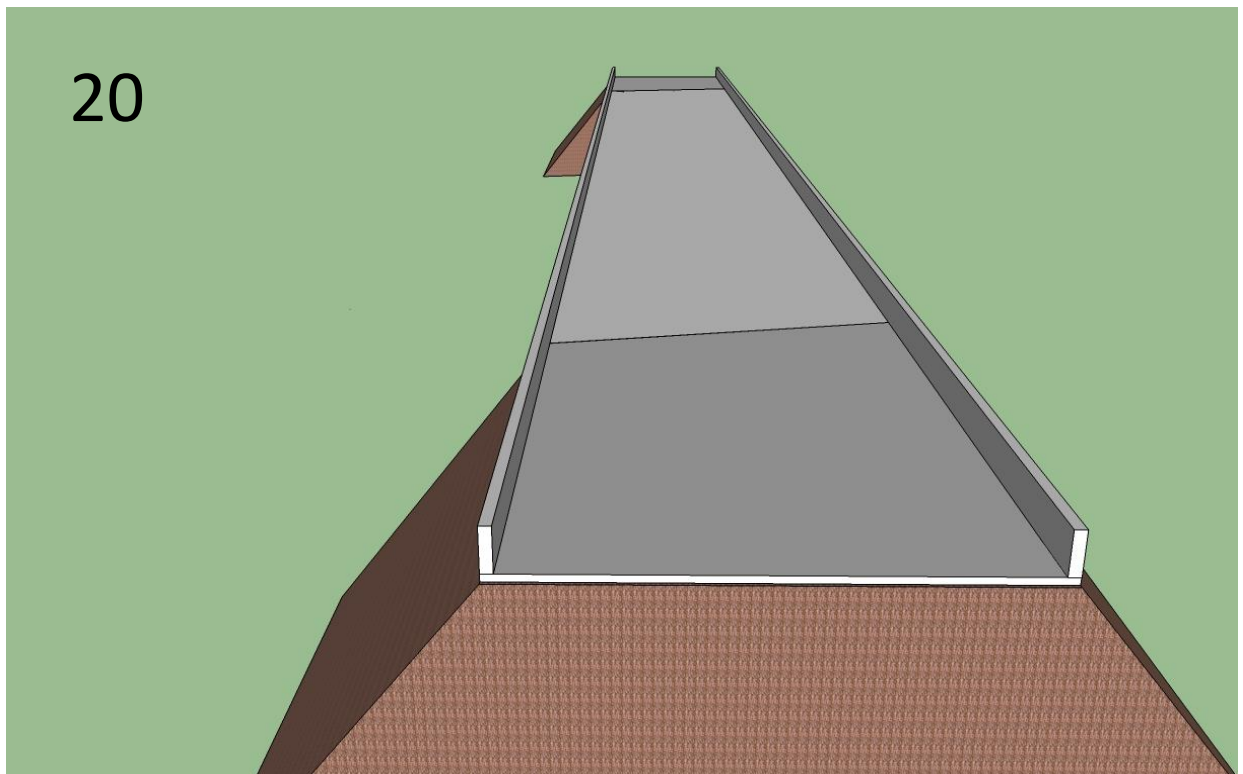
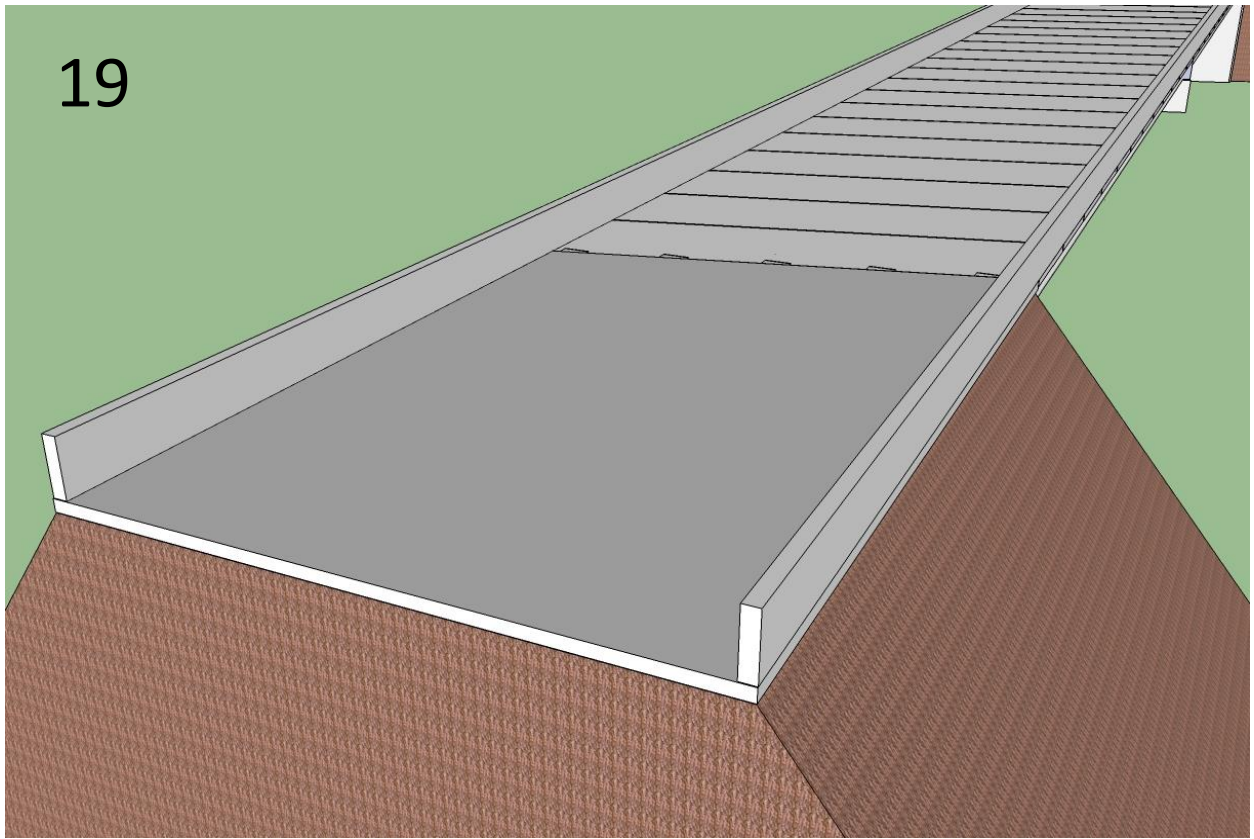

Figure 3.1: Construction Steps of Precast Concrete Deck System of Kearney East Bypass Project

4 ANALYSIS, DESIGN, AND DETAILING

The northern bound of the Kearney East Bypass bridge project consists of 26 NUDECK typical panels and 2 NUDECK end panels as shown in Figure 4.1. Each typical panel is 41 ft 8 in. wide, 12 ft long, 8 in. thick and has 15 shear pockets (3 shear pockets per girder line at 4 ft spacing) as shown in Figure 4.2. Eight pockets are type A, which have lifting inserts, and seven pockets are type B, which are non-lifting pockets. Figure 4.3 shows the plan and sectional views of pockets type A and B.

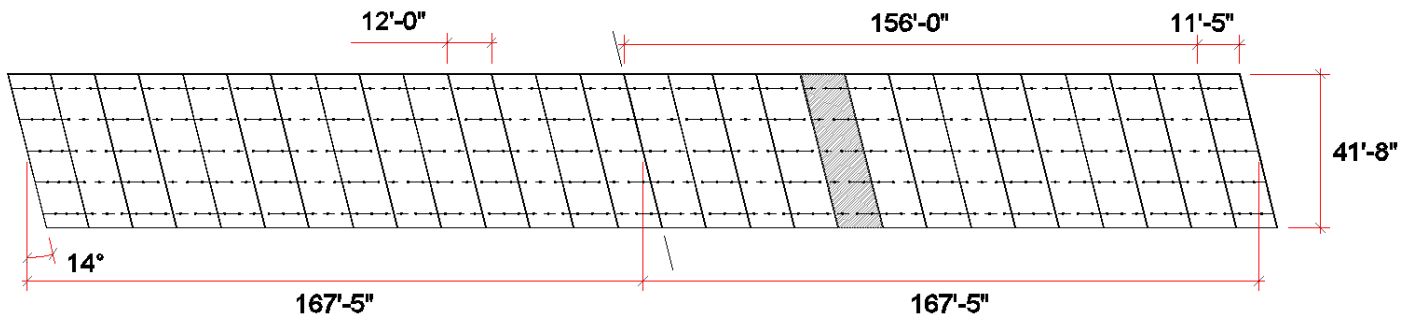

Figure 4.1: NUDECK panel arrangement for Kearney East Bypass project

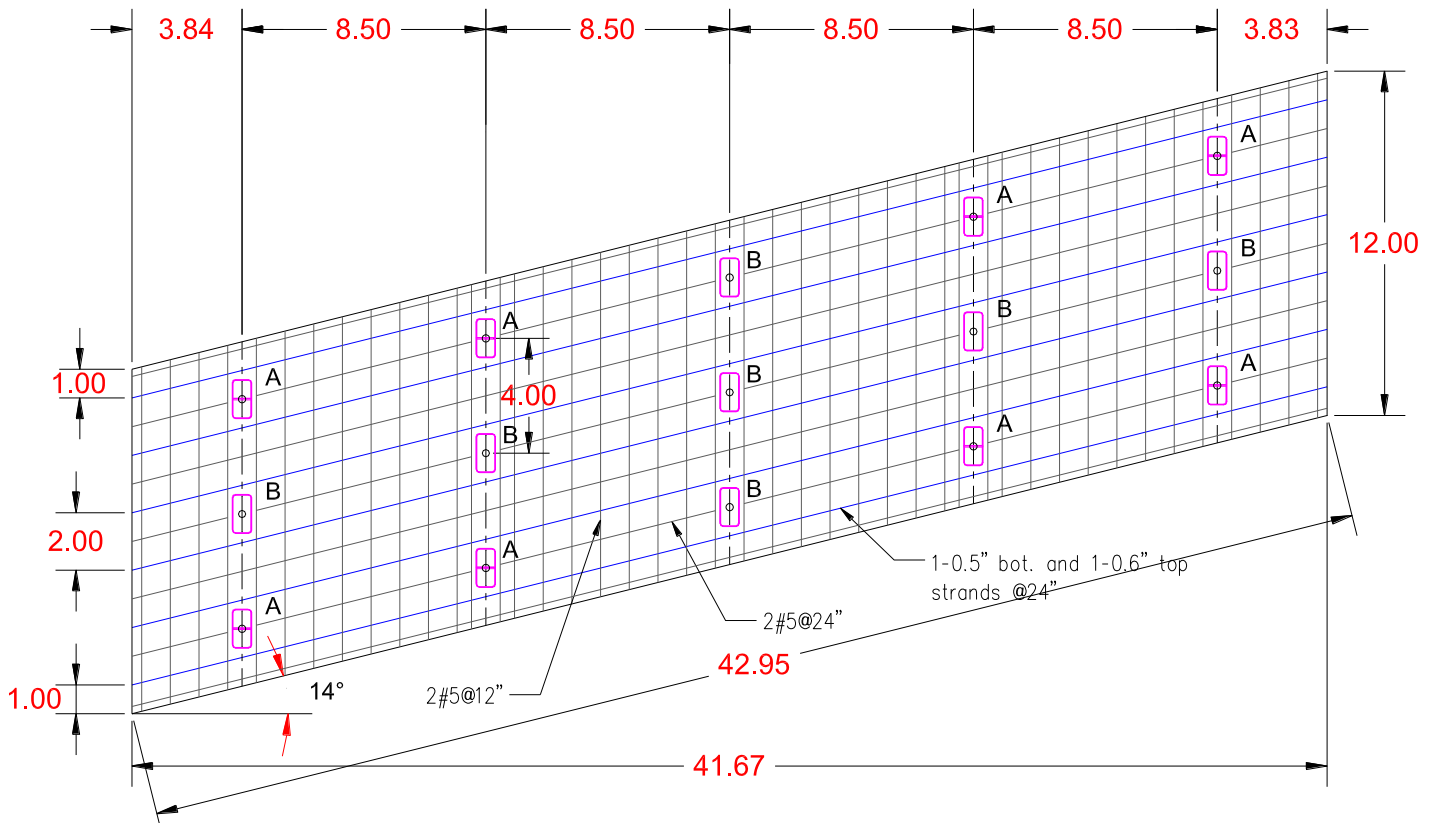
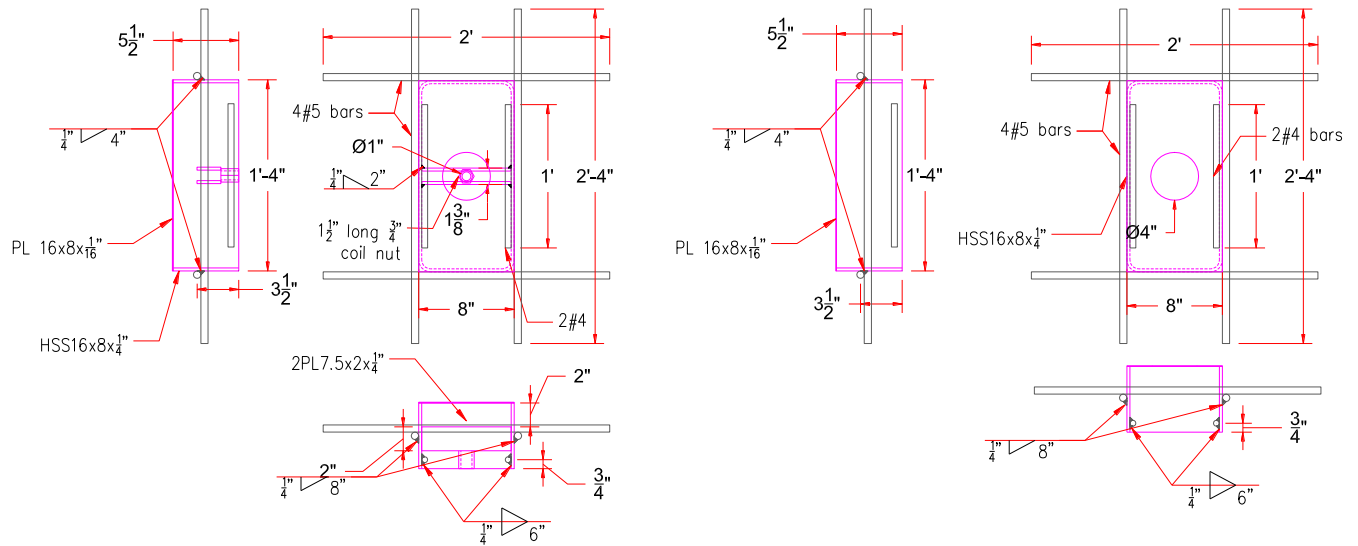

Figure 4.2: Typical panel plan view and reinforcement details



Pocket Type A
Pocket Type B

Figure 4.3: Plan and sectional views of pockets type A and B

To determine the necessary transverse prestressing of each typical panel, the panel was analyzed as a continuous beam under both lifting and service conditions using Beam Express software. Figure 4.4 shows the bending moment, shear force, and deflection diagrams of a typical panel during lifting. These diagrams indicate that the maximum positive moment is 20.1 kip.ft, maximum negative moment is 23.3 kip.ft, maximum shear is 10.2 kip, and maximum deflection is 0.04 in. Figure 4.5 shows the bending moment, shear force, and deflection diagrams of a typical panel during service condition under its self-weight. These diagrams indicate that the maximum positive moment is 1.5 kip.ft, maximum negative moment is 2.4 kip.ft, maximum shear is 3.3 kip, and maximum deflection is 0.0003 in. Using the AASHTO LRFD⁷ Table A4.1, maximum positive moment of 6 kip.ft/ft and maximum negative moment of 3.3 kip.ft/ft were estimated due to live loads. The factored positive and negative moments in a typical panel for Strength I limit state are estimated as follows:

$$M_u(+ve) = 1.25 \times 1.5 + 1.75 \times 6 \times 12 \times 1.2 = 153 \text{ kip.ft}$$

$$M_u(-ve) = 1.25 \times 2.4 + 1.75 \times 3.3 \times 12 \times 1.2 = 86.2 \text{ kip.ft}$$

Using strain compatibility analysis of the deck section assuming $f'_{ci} = 3.5 \text{ ksi}$, $f'_c = 6 \text{ ksi}$, total thickness = 7.5 in. (after 1/2" grinding), 6-0.5 in. strands + 7#5 bars are located at 6.25 in. from the top, and 6-0.6 in. strands + 7#5 bars are located at 2.25 in. from the top, the following capacities are calculated:

$$\Phi M_n (+ve) = 234 \text{ kip.ft} > 153 \quad \text{OK}$$

$$\Phi M_n (-ve) = 180.4 \text{ kip.ft} > 86.2 \quad \text{OK}$$

Table 4.1 shows top and bottom stress calculations in the transverse direction for both lifting and service conditions. These calculations indicated that the panel will not have any tensile stresses during lifting and minimal tensile stresses under service loads. It should be noted that a 1.5 impact factor was used in stress calculations during lifting. Also, prestressed losses were calculated to

be 3.2 ksi at release and 17.9 ksi at service. Tables 4.2 and 4.3 show the design of pocket anchor bars and lifting inserts respectively.

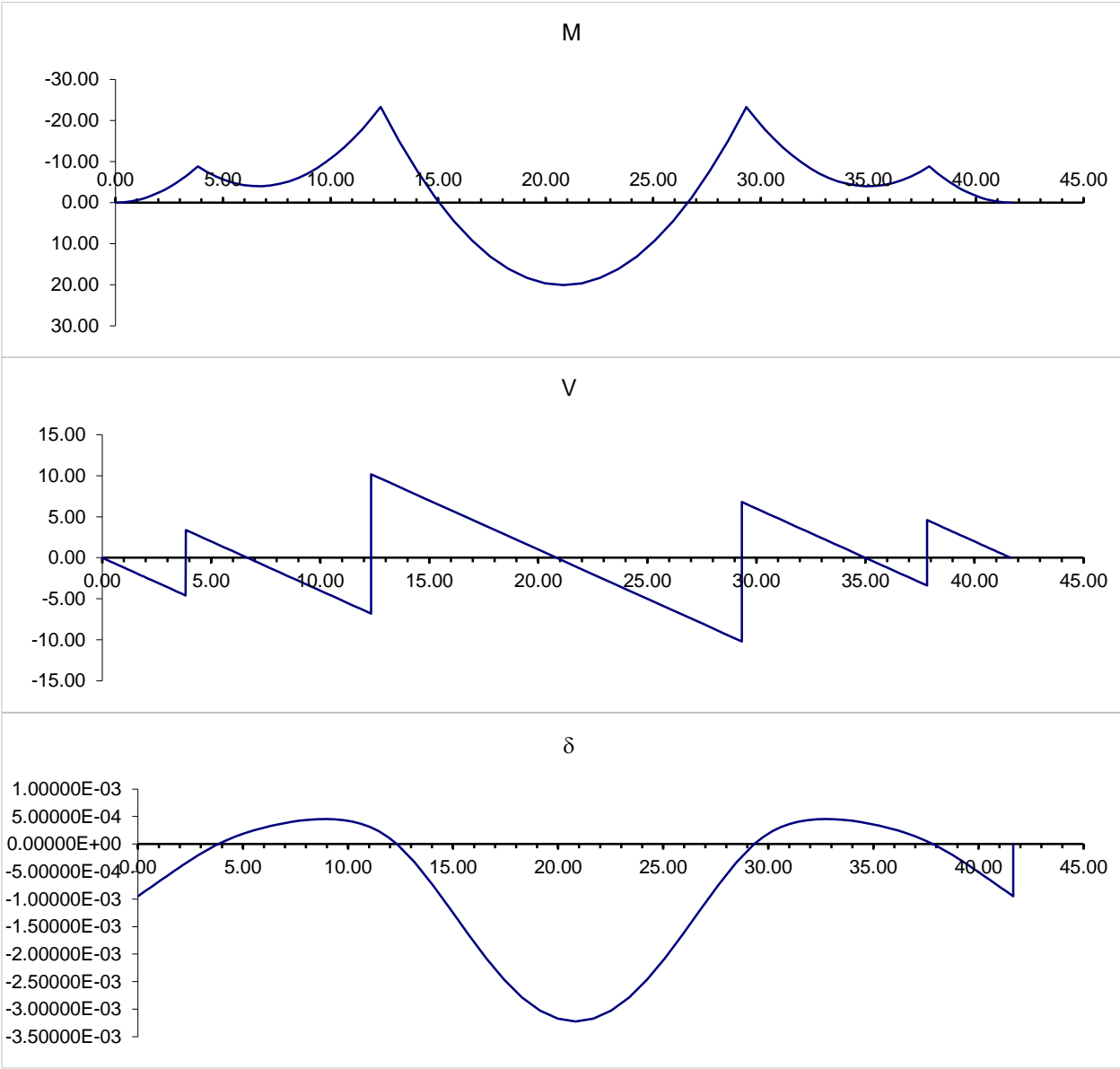

Figure 4.4: Bending moment, shear force, and deflection diagrams of a typical panel during lifting (kip,ft)

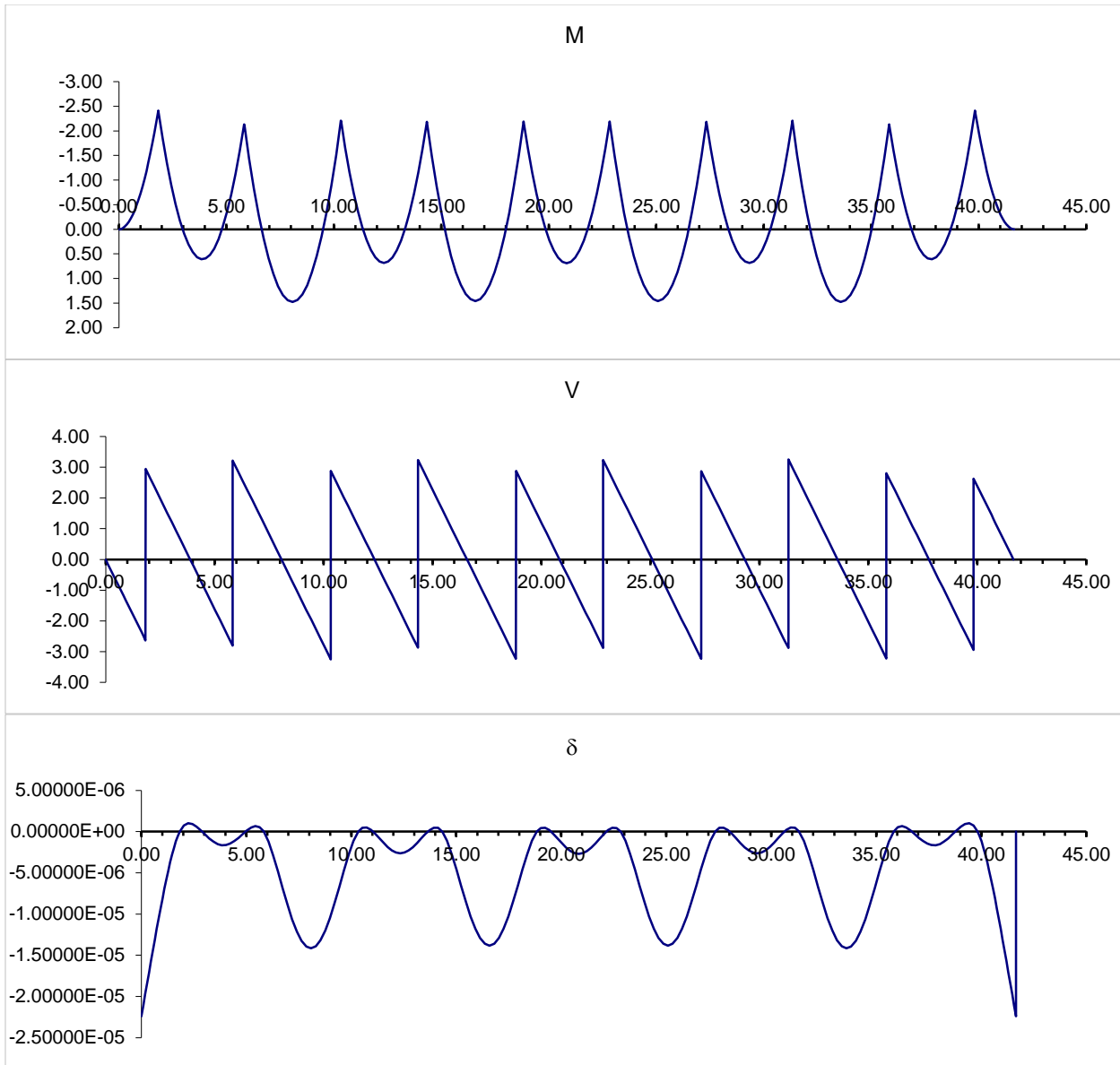

Figure 4.5: Bending moment, shear force, and deflection diagrams of a typical panel at service condition under self-weight (kip.ft)

Table 4.1: Deck stress calculations during lifting and service conditions

General Information			Stage I (At Lifting)					
Deck Width (b)	12	ft	P	442.4	kip	M_{-ve}	-419.4	k.in
Deck Thickness (h)	8.00	in	f_{top}	0.00	ksi	$-0.098 \sqrt{f'_{ci}}$	-0.18	ksi OK
f'_{ci}	3,500	psi	f_{bot}	0.77	ksi	$0.6 f'_{ci}$	2.10	ksi OK
f'_c	6,000	psi						
f_{pu}	270	ksi	P	442.4	kip	M_{+ve}	361.8	k.in
f_{py}	243	ksi	f_{top}	0.50	ksi	$-0.098 \sqrt{f'_{ci}}$	-0.18	ksi OK
f_{pj}	202.5	ksi	f_{bot}	0.26	ksi	$0.6 f'_{ci}$	2.10	ksi OK
f_{pt}	199.3	ksi						
f_{pe}	184.6	ksi						
n_{ps}	12	Each	Stage II (At Service)					
e	0.40	in	P	409.8	kip	M_{-ve}	-504.0	k.in.
A_{ps} (6-0.5" bot + 6-0.6" top)	2.22	in ²	f_{top}	-0.08	ksi	$-0.098 \sqrt{f'_c}$	-0.23	ksi OK
			f_{bot}	0.79	ksi	$0.6 f'_c$	3.60	ksi OK
Section Properties								
A	1152	in ²	P	409.8	kip	M_{+ve}	882.0	k.in.
Y_b	4	in	f_{top}	0.82	ksi	$0.6 f'_c$	3.60	ksi OK
Y_t	4	in	f_{bot}	-0.11	ksi	$-0.098 \sqrt{f'_c}$	-0.23	ksi OK
I	6,144	in ⁴						

Table 4.2: Design of pocket anchor bars and their welds

Design of Anchor Bars

Area of One Shear Connector	0.97	in ²
Design Strength of Connectors	60	ksi
Number of Connectors / Pocket	2	Each
Total Pullout Force	116.4	kip
Cross Section Area of Anchor Bars	0.31	in ²
Yield Strength of Anchor Bars	60	ksi
Number of Shear Planes	8	Each
Resistance Factor in Shear	0.75	N/A
Capacity of Anchor Bars in Shear	111.6	in.
Surface Area of HSS	264	in ²
Cohesion Coefficient	0.025	ksi
Cohesion Force	5.9	kip
Total Resistance	117.5	kip OK

Design of Welds

Weld Thickness	0.25	in.
Effective Fillet Weld Thickness	0.10	in.
Strength of Welding Electrode	90	ksi
Angle of Load to Weld Axis	90	deg.
Length of Each Weld Line	4.0	in.
β Factor	1.0	N/A
Number of Weld Lines	6	Each
Factored Weld Capacity	138.3	kip OK

Table 4.3: Design of pocket lifting inserts and their welds

Design of Lifting Plates

Panel Length	41.67	ft	
Panel Width	12	ft	
Panel Thickness	8	in	
Panel Weight	48.34	kip	
Number of Lifting Points	8	EA	
Maximum Load Per Lifting Point	8.50	kip	
Load Factor for Impact	4		
Design Load	34.0	kip	
Span of Lifting Plate	7.5	in	
Diameter of Coil Rod	0.75	in.	
Capacity of Coil Rod	7.2	kip	
Diameter of Coil Nut	1.375	in.	
Moment in Lifting Plate	26.0	kip.in.	
Steel Grade	50	ksi	
Plastic Section Modulus	0.52	in ³	
Total Thickness of Lifting Plates	0.50	in.	2- 1/4" thick plates
Required Depth of Lifting Plates	2.0	in.	Use 2 in.

Design of Welds

Weld Thickness	0.25	in.	
Effective Fillet Weld Thickness	0.18	in.	
Strength of Welding Electrode	90	ksi	
Angle of Load to Weld Axis	0	deg.	
Length of Each Weld Line	1.5	in.	
β Factor	1.0	N/A	
Number of Weld Lines	4	Each	
Factored Weld Capacity	43.0	kip	OK

Each deck panel need to be supported on the five girder lines creating a haunch that has a minimum thickness of 3 in. to accommodate the post-tensioning strands and to be filled with concrete after post-tensioning. To achieve that, bent plates was chosen to be welded to the metal tabs inserted in both edges of the top flange of each precast girder to create a continuous support and side forms for the cast-in-place concrete. The welding process will be done on-site after conducting shim shoots to determine the required deck elevation. Table 4.4 shows the design calculations of the bent plate and its welds assuming that metal tabs are spaced at 18 in. and the NU girder top flange has an ultimate capacity of 4 kip/ft acting on the tip of the flange. Also, at least 1/2" thick compressive material is needed to uniformly distribute the panel weight and prevent leakage. Based on these calculations, the maximum wheel load allowed during construction is 2,000 lbs.

Table 4.4: Design of deck support system

Design of Bent Plates

Panel Length	41.67	ft	
Panel Width	12	ft	
Panel Thickness	8	in	
Panel Weight	48.34	kip	
Number of Support Lines	5	EA	Assume one angle per girder line
Length of Each Support Line	12	ft	
Load Per Linear Foot	0.81	kip/ft	
Load Factor for Impact	4		
Design Load	3.22	kip/ft	
Girder Capacity per Linear Foot	4	kip/ft	OK
Spacing Between Welds	1.5	ft	
Load per Weld	4.83	kip	
Applied Moment	43.50	kip.in.	Assume one weld is broken
Bent Plate Thickness	0.125	in.	
Bent Plate Width	3	in.	
Bent Plate Depth	6	in.	
Steel Grade	50	ksi	
Section Modulus	2.12	in ³	
Moment Capacity	106	kip.in.	OK

Design of Welds

Weld Thickness	0.125	in.	
Effective Fillet Weld Thickness	0.09	in.	
Strength of Welding Electrode	90	ksi	
Angle of Load to Weld Axis	0	deg.	
Length of Each Weld Line	1.50	in.	
β Factor	1.00	N/A	
Number of Weld Lines	1.00	Each	
Factored Weld Capacity	5.4	kip	OK

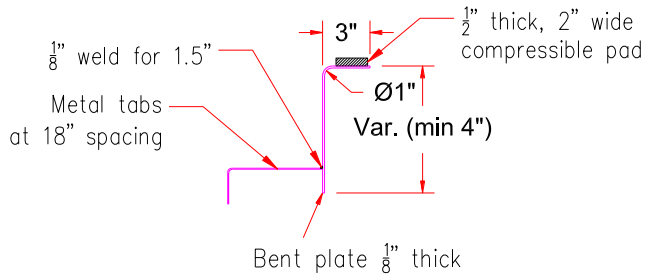

Maximum Wheel Load

Dead Load Per Tab	1.21	kip	
Dead Load Factor	1.25	N/A	
Wheel Load	2	kip	
Live Load Factor	1.35	N/A	
Impact Factor	1.33	N/A	
TOTAL Load	5.1	kip	OK

To design the panel-to-girder connection and the deck post-tensioning, the entire bridge superstructure was modeled and analyzed using ConSpan V8i software. Appendix A lists the analysis results for an interior girder, which includes service and ultimate shear and moment envelopes as well as the interface shear at different section. Based on analysis results, maximum positive and negative ultimate moments were 15,189 kip.ft and 6,870 kip.ft respectively. These values compared very well with the flexural capacity of the composite girder calculated using strain compatibility ($M_n(+ve) = 21,347$ kip.ft and $M_n(-ve) = 7,080$ kip.ft). The vertical shear at the critical section was found to be 254 kip, which resulted in an interface shear of 3.24 kip/in (excluding the girder and deck weight effects). This value was used in Table 4.5 to design the shear connectors according to AASHTO LRFD⁷ section 5.8.4, which found to be two 1.25 in. diameter threaded rods at 4 ft spacing. It should be noted that the cohesion between the haunch concrete and the precast deck soffit was assumed to be zero as the deck soffit is not roughened.

Table 4.5: Design of shear connectors

Vertical Shear at Critical Section (V_u)	254	kip
Effective Depth (d_e)	78.3	in.
Max. Interface Shear ($V_{ui,max}$)	3.24	kip/in.
Design Interface Shear	3.24	kip/in.
Spacing Between Shear Connectors (s)	48	in.
Ultimate interface Shear per pocket (V_{ui})	155.7	kip
Area of One Shear Connectors (A_s)	0.97	in ²
Yield Strength of Shear Connectors	105	ksi
Design Yield Strength of Shear Connectors (f_y)	60	ksi
Number of Shear Connectors per pocket	2	
Compressive Strength of Grout (f'_c)	6	ksi
Resistance Factor (ϕ)	0.9	

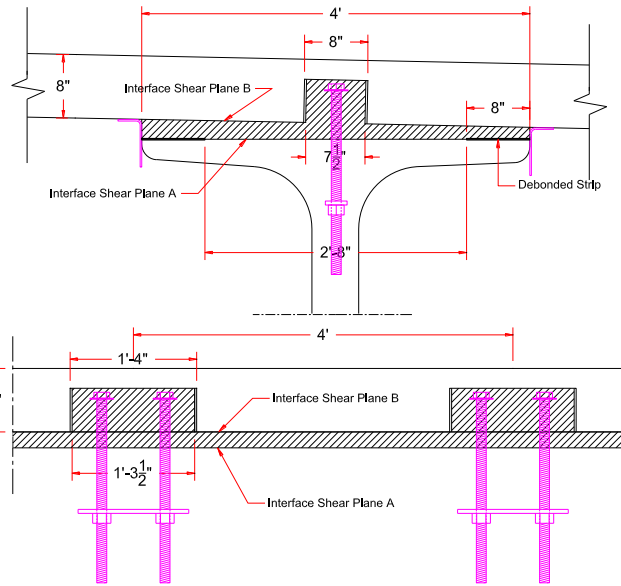

Failure Plane	Length (in.)	Width (in.)	A_{cv} (in. ²)	c (ksi)	μ	K_1	K_2 (ksi)	$c A_{cv}$ (kip)	$\mu A_s f_y$ (kip)	$K_1 f'_c A_{cv}$ (kip)	$K_2 A_{cv}$ (kip)	ϕV_n (kip)
A (at the girder top flange)	48	32	1,536	0.24	1	0.25	1.5	368.6	116.4	2,304	2,304	436.5
B (at the deck bottom surface)												156.9
B ₁ (At the pocket)	15.5	7.5	116.3	0.4	1.4	0.25	1.5	46.5	163.0	174	174	156.9
B ₂ (between pockets)	48	32	1419.8	0	0	0.2	0.8	0.0	0.0	1,704	1,136	0.0

According to AASHTO LRFD Section 5.8.4

Also, the maximum positive and negative service III bending moments were 9,682 kip.ft, 3,014 kip.ft respectively. These values were used to determine the required pre-tensioning force at the positive moment region and post-tensioning force at the negative moment region to keep the tensile stresses less than $0.098 \sqrt{f'_c}$. This resulted in using 60-0.6 in. pre-tensioned strands at the bottom flange and 12-0.6 in. post-tensioned strands at the haunch for each girder. Table 4.6 shows the design calculations for deck post-tensioning. Figures 4.6, and 4.7 show detailing of deck-to-girder connection for a typical panel and end panel respectively. Figures 4.8 and 4.9 show, respectively,

the proposed design and alternate design of post-tensioning hardware. Also, NDOR project sheets that are relevant to these connections are shown in Appendix B

Table 4.6: Design of deck post-tensioning

BRIDGE INFORMATION		
Location	Kearney East Bypass	
County	Buffalo	
Number of Spans	2	
Span Length	166	ft
Total Width	41.67	ft
Roadway Width	39	ft
Skew Angle	14	deg.
GIRDER INFORMATION		
Girder Size	NU1800	
Girder Height	70.9	in
Girder Area	857.3	in ²
Girder Inertia	611,328	in ⁴
Girder Y_b	32	in
Girder f_c'	8	ksi
Number of Girders	5	
Girder Spacing	8.5	ft
DECK INFORMATION		
Deck Thickness	7.5	in
Haunch Thickness	6.5	in
Haunch Width	48	in
Deck and Haunch f_c'	6	ksi
Rail Type	Closed 42"	
Rail Weight	0.524	klf
Wearing Surface	0.02	ksf
COMPOSITE SECTION		
Modular Ratio	0.866	
Area of Composite	2,066.9	in ²
Composite Y_b	52.53	in
Composite Inertia	1,900,275.10	in ⁴
FORCES AND STRESSES		
Critical Section	Face of Diaphragm	
M-ve (Total)	-3014	kip.ft
Post-tensioning Force	421.8	kip
P/A	0.551	ksi
My/I	-0.616	ksi
Total Stress	-0.065	ksi
Stress Limit $0.098v_f'c$	-0.240	ksi

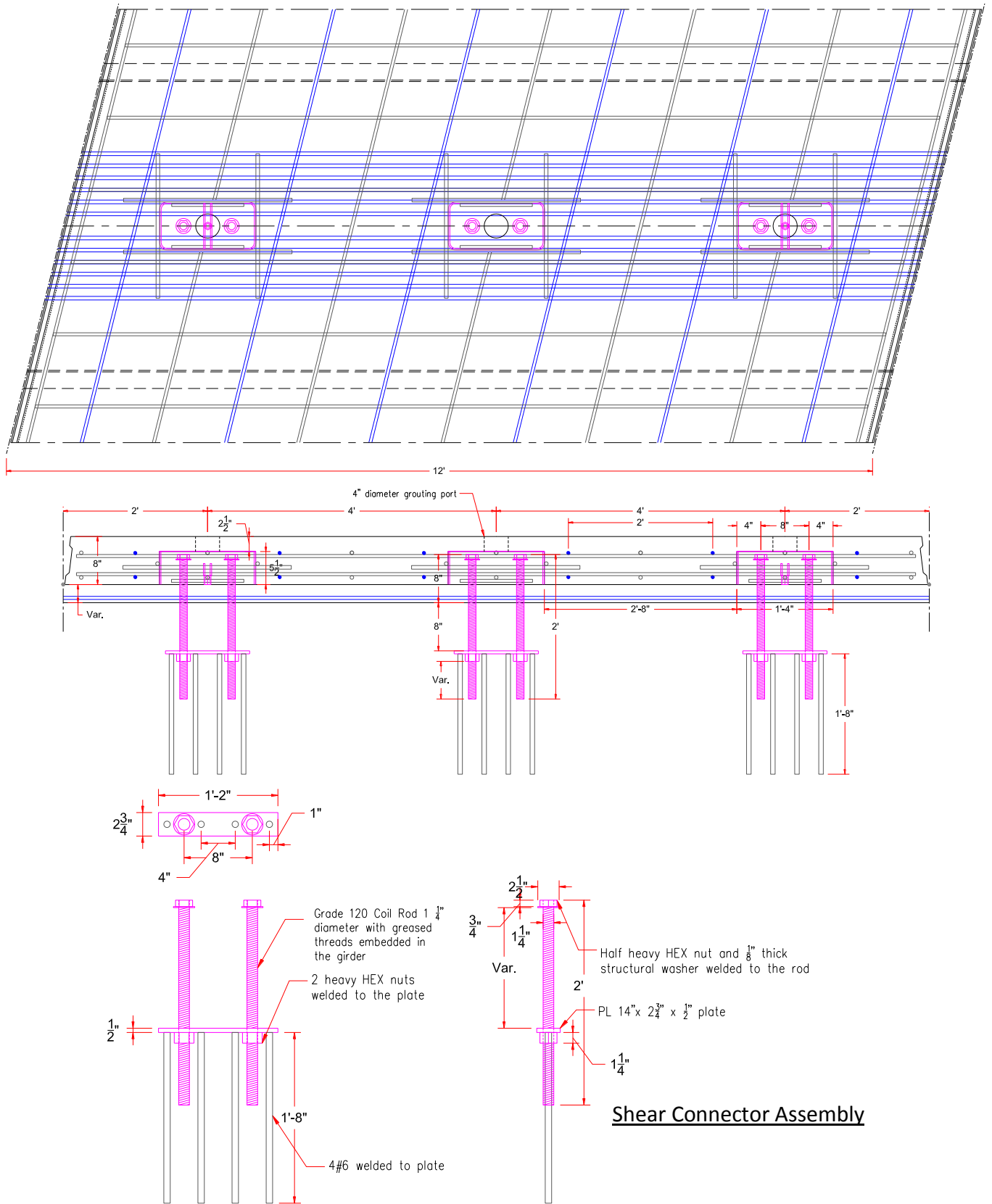
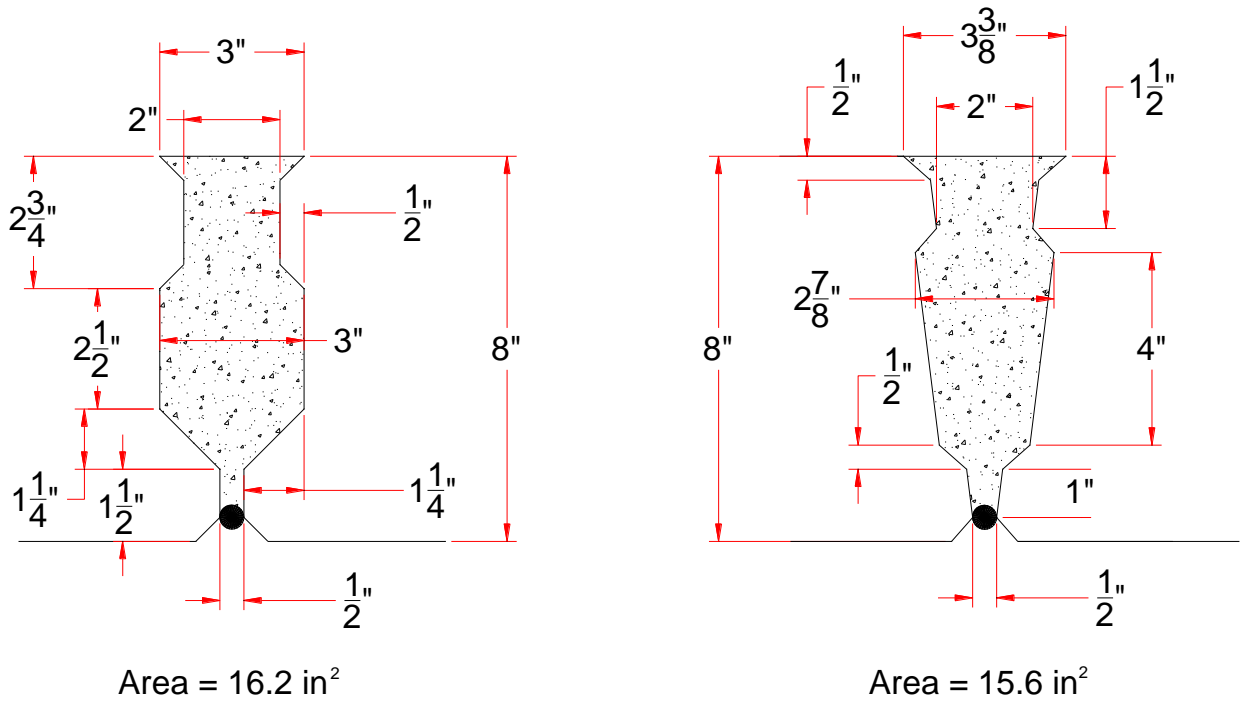
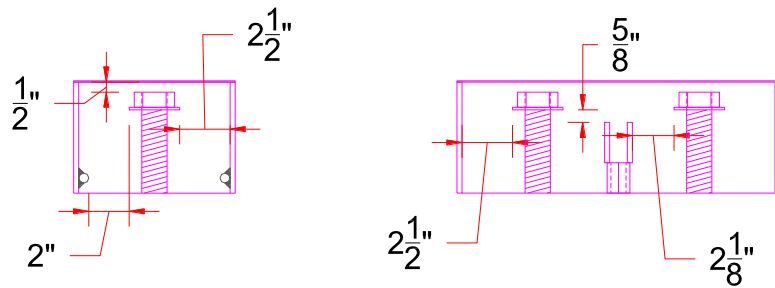

Figure 4.6: Typical panel-to-girder connection views (cont.)



Transverse Joint Alternatives



Shear Pocket Tolerances

Figure 4.6: Typical panel-to-girder connection views (cont.)

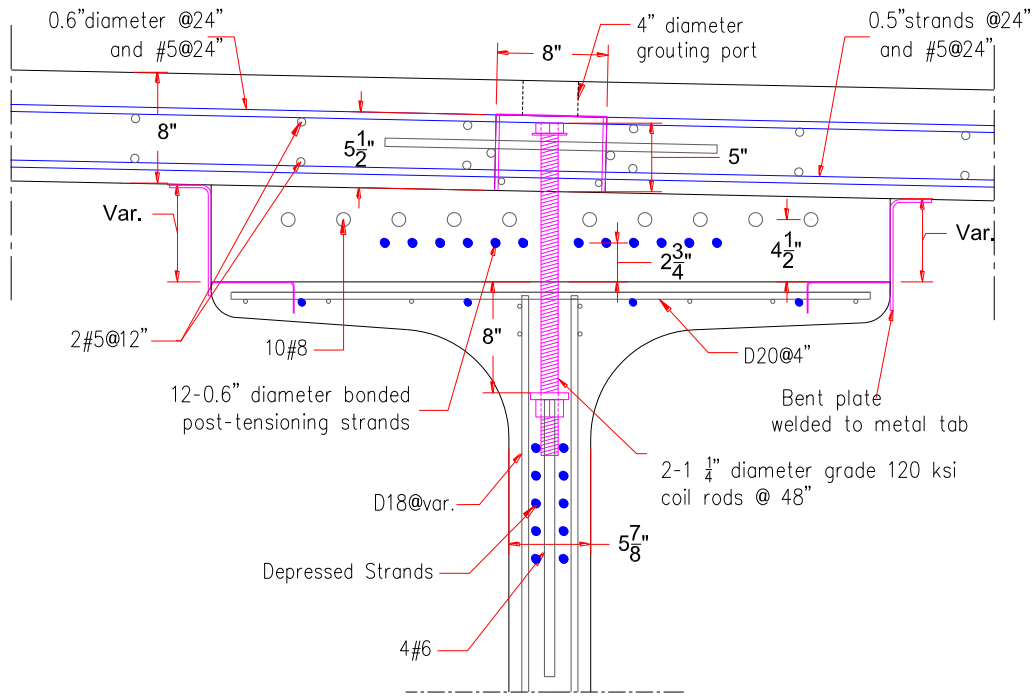

Intermediate Support Section

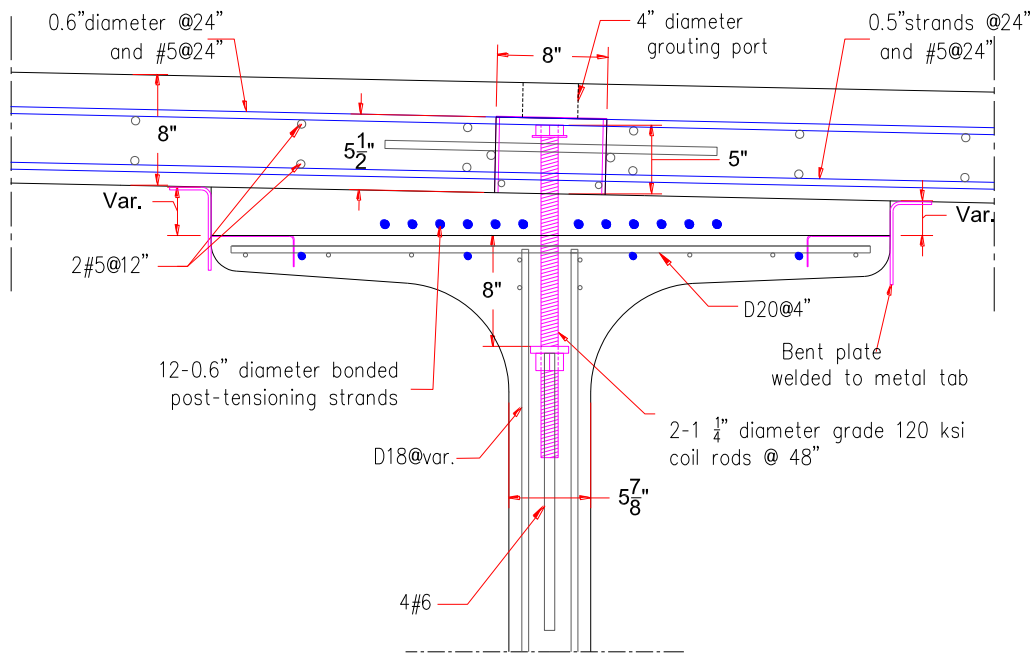

Mid-Span Section

Figure 4.6: Typical panel-to-girder connection views

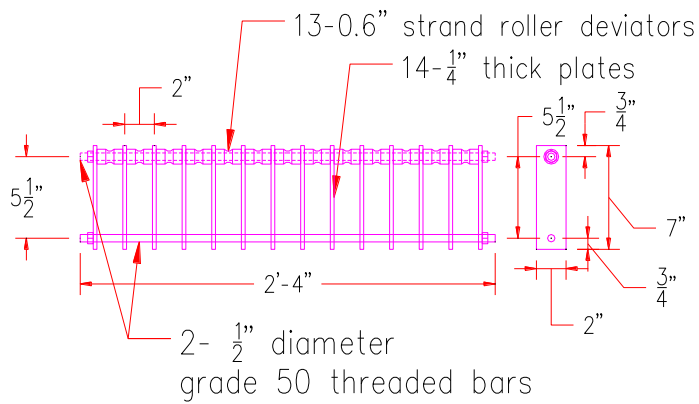
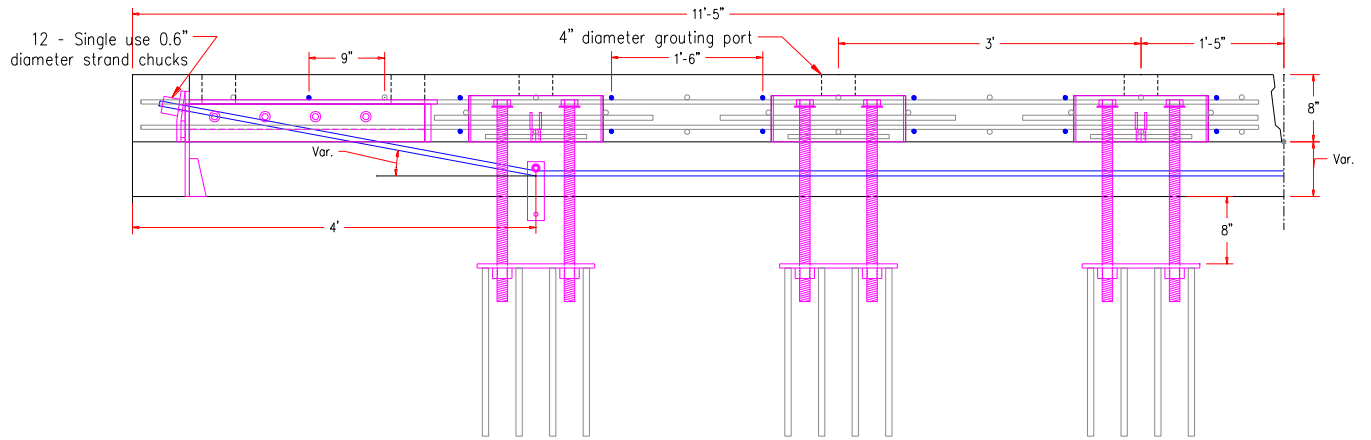
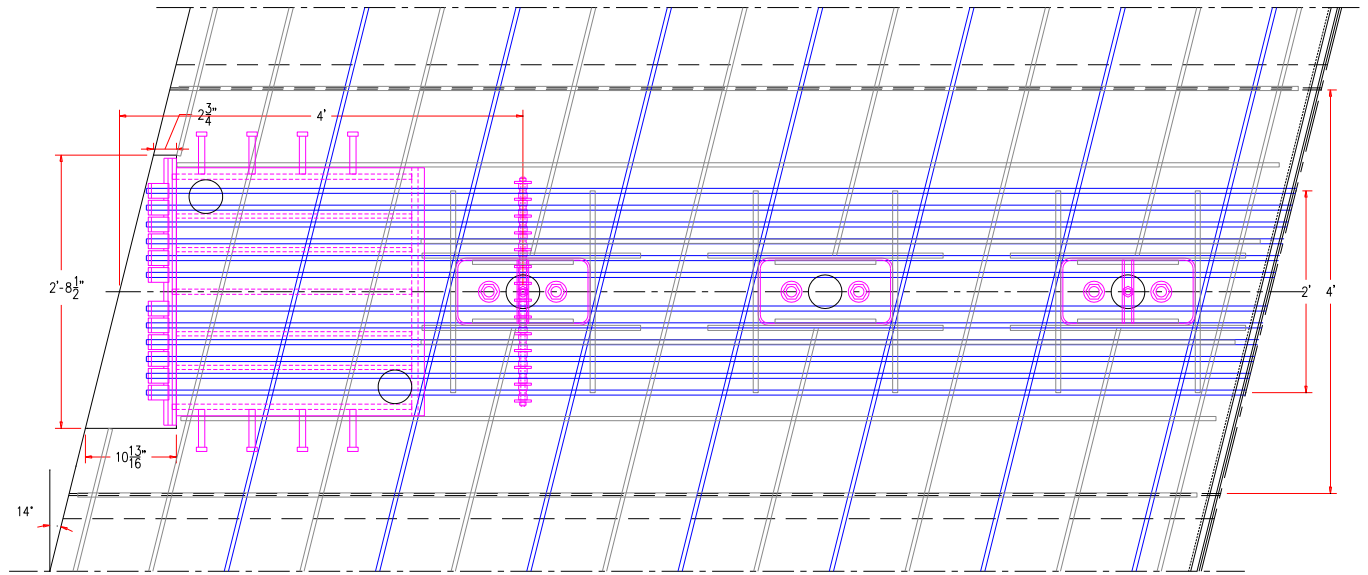

Strand Deviators

Figure 4.7: End panel-to-girder connection views (cont.)

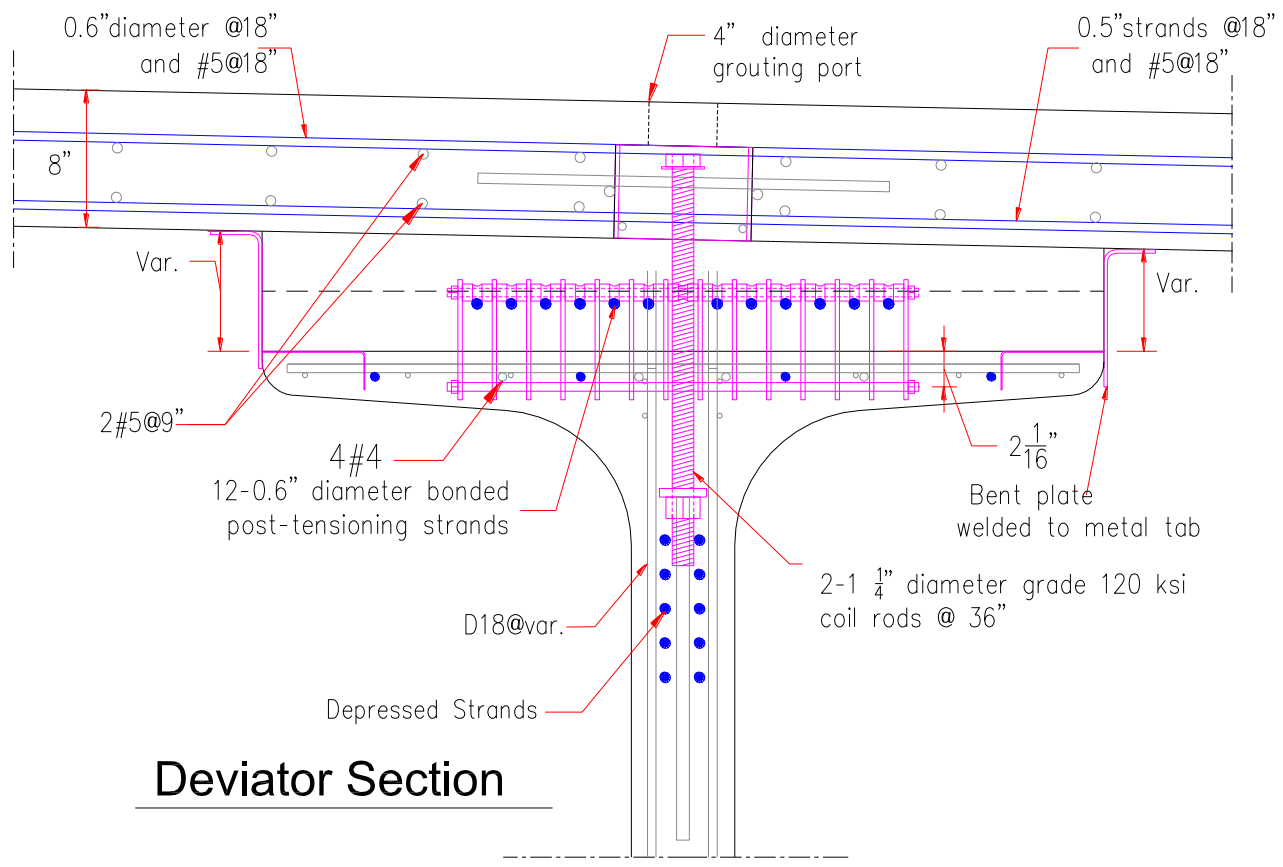
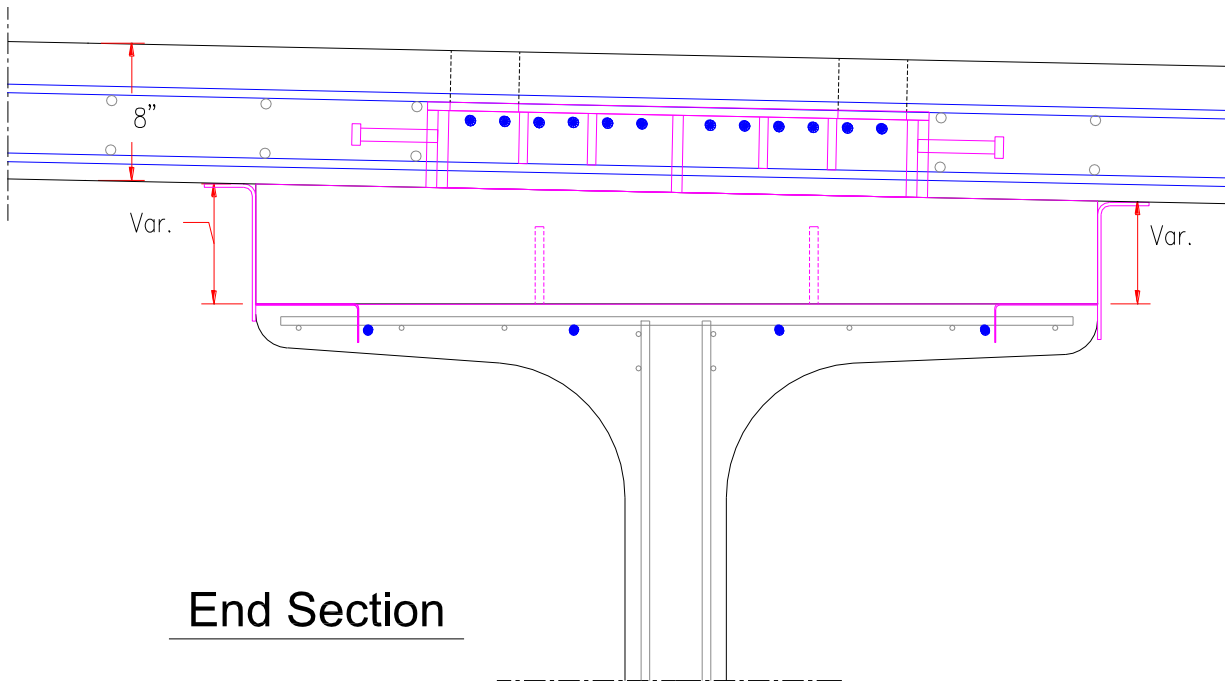
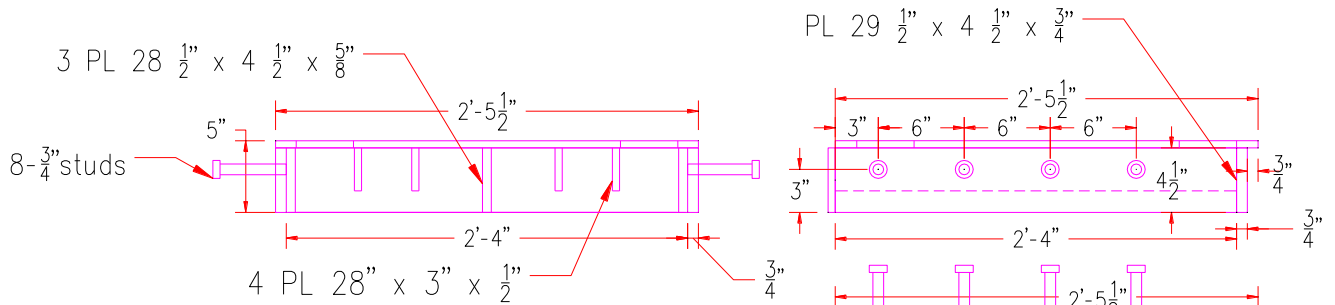
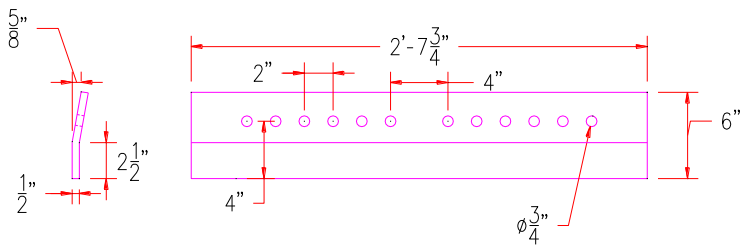
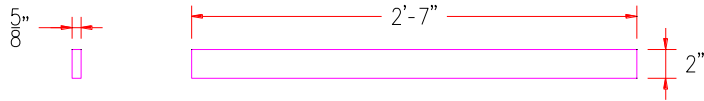
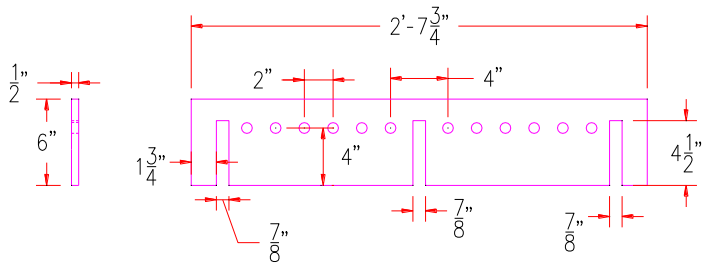
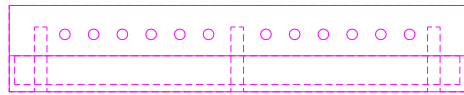
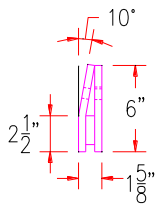

Figure 4.7: End panel-to-girder connection views



Anchor Block

All plates are welded with 1/4" fillet weld



Anchor Plate

All plates are welded with 1/4" fillet weld

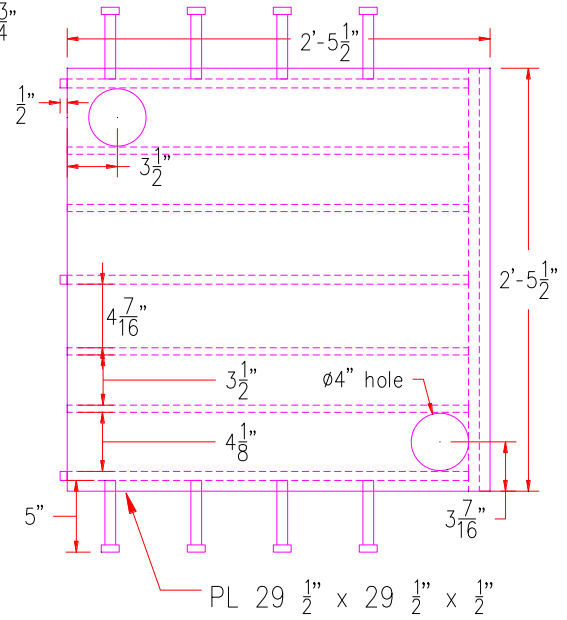

Figure 4.8: Detailing of post-tensioning anchor block and plate

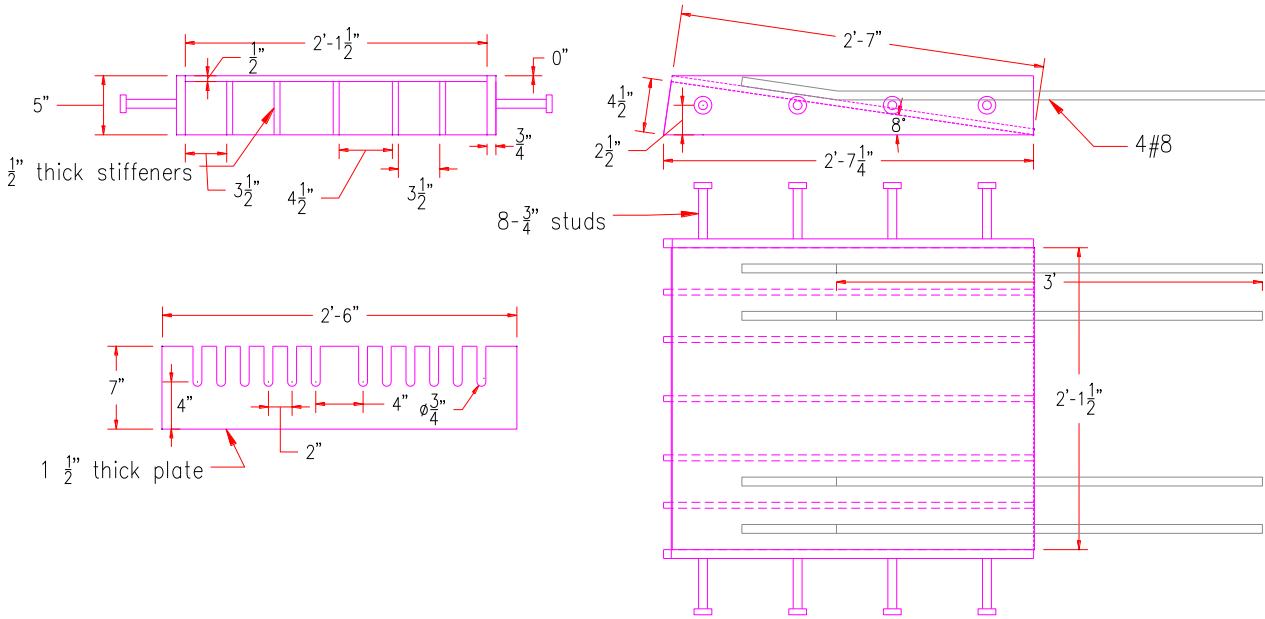

Figure 4.9: Alternate design of post-tensioning anchor block and plate

5 PULLOUT EXPERIMENTAL INVESTIGATION

5.1 Girder Pullout Testing

The purpose of this testing was to determine the required embedment length of the threaded rods (TRs) used as shear connectors into the girder, so that the TR can be fully developed. Another purpose was to determine the most efficient way to grease the TR so it can be cranked up when needed to adjust the TR height to match the deck profile. Testing was conducted on three stages:

- 1) Pullout from concrete cubes (05-24-2012);
- 2) Pullout from shallow T-girders (07-13-2012); and
- 3) Pullout from deep T-girders (07-27-2012 and 02-13-2013).

In the first stage, three concrete cube specimen 1 ft x 1 ft x 1 ft were made with 1.25 in. diameter TR embedded in the center of each cube as shown in Figure 5.1 Two of the specimens had TR with fine threads (7 threads per inch), while the third specimen had TR with coarse threads (4 threads per inch) to determine the effect of number of threads on the bond and the ease of cranking. Also, one of the TR with fine threads was not greased to determine the effect of greasing on the bond with concrete. Figure 5.2 shows a photo of one of the specimen before casting the concrete. Two TR were greased using thick grease commonly used as a lubricant for heavy equipment, which makes it stay on the rods surface and not drip inside the form. A 6,000 psi self-consolidating concrete (SCC) was used to cast the specimens. When the concrete strength reached 3,500 psi, the TR were cranked up using a manual wrench as shown in Figure 5.2. The two greased rods were easily cranked up and down, while the bond between the non-greased rod and concrete could not be broken. All the three specimens were tested in pullout as shown in the test setup in Figure 5.3.

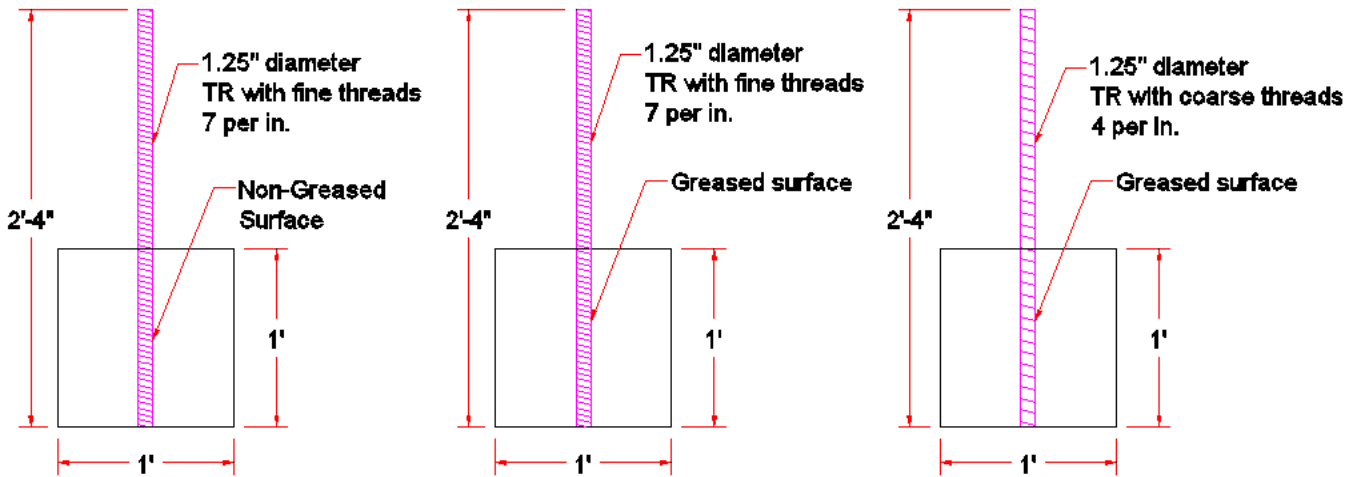

Figure 5.1: Elevations of the three specimen tested in the first stage

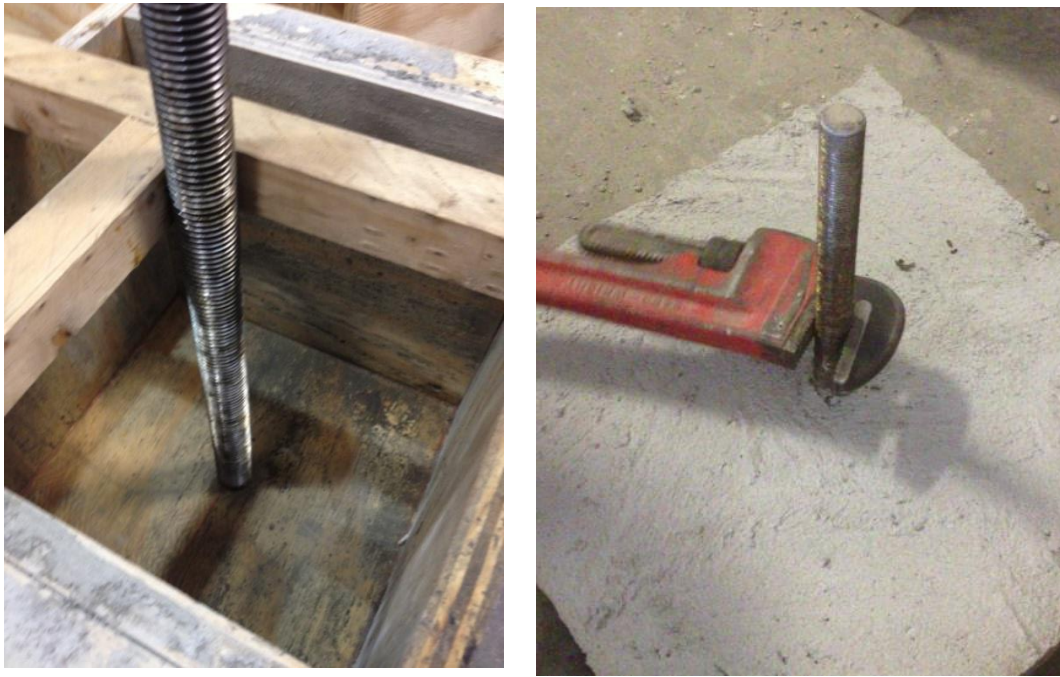

Figure 5.2: Cube specimen with TR before casting (left) and after casting (right)



Figure 5.3: Pullout test setup

Figure 5.4 plots the pullout testing results of the three specimens. This plot indicates that both greasing and coarseness of threads had a significant effect on the bond with concrete. The non-greased TR had better bond with concrete than the greased TR with the same coarseness of threads, which can lead to splitting of the concrete rather than pullout of the rod. On the other hand, the coarser the threads, the higher the bond with concrete as the concrete can better fill the space between threads especially when grease is being applied. Figure 5.5 shows the failure mode of each specimen. Despite these results, it was decided to use a greased TR to allow easy cranking of the rods in the site. Also, TR with fine threads were used to allow using a thinner nut (i.e. half nut) to form the head of the rod, which will be embedded inside the deck shear pockets. However, a large washer and nut will be used on the other end embedded in the girder to improve the TR bond with concrete, which was tested in the second and third stages.

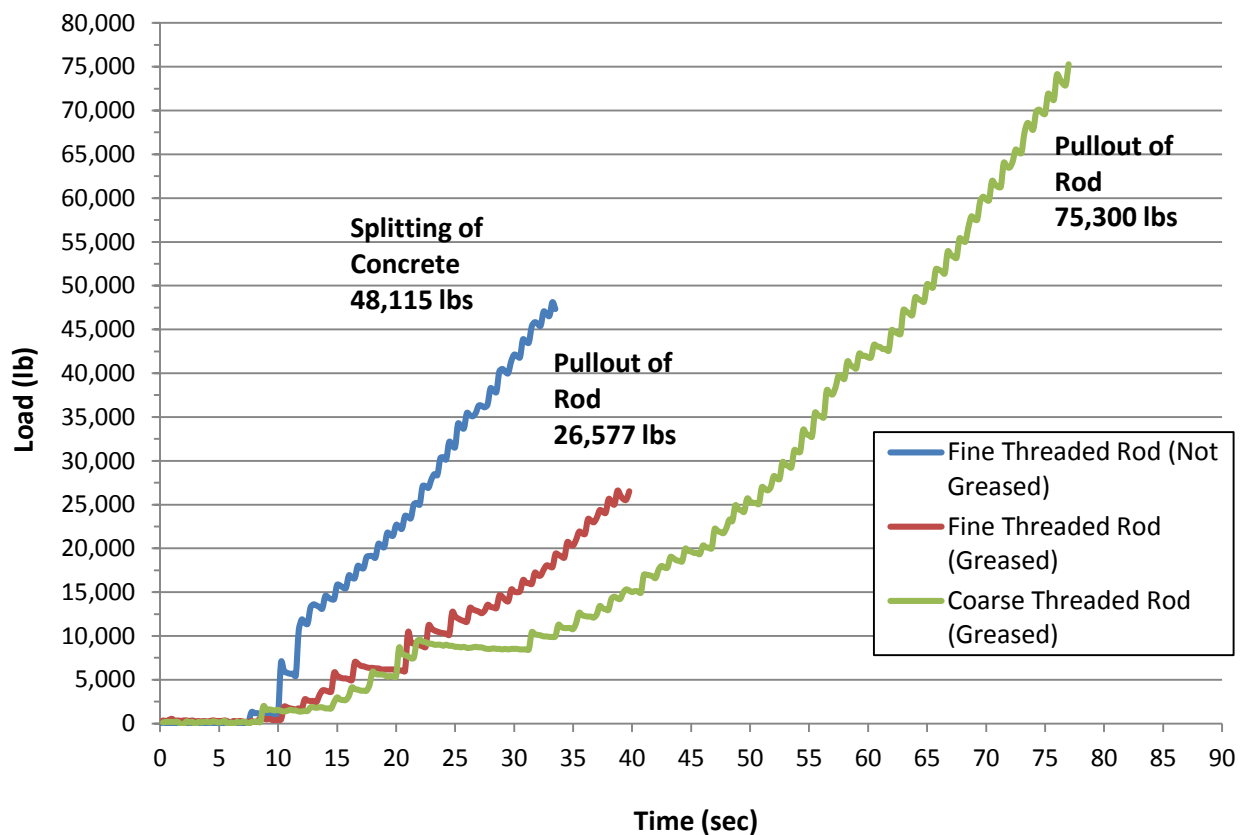
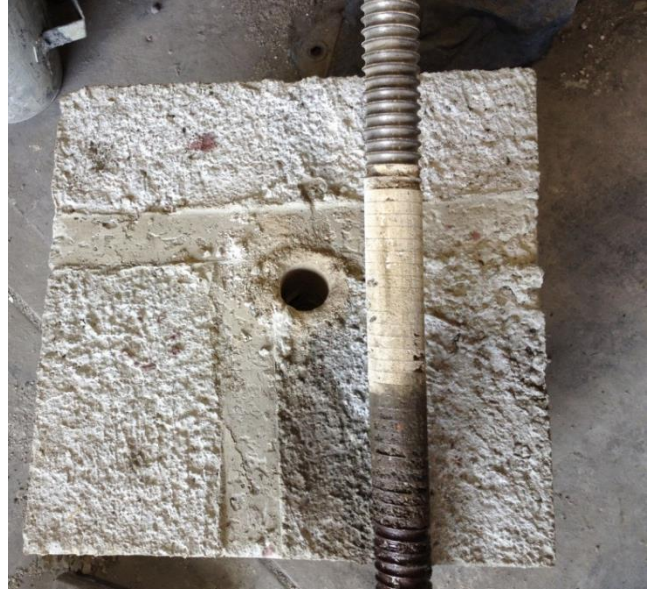

Figure 5.4: Pullout test results



a)



b)



c)

Figure 5.5: Failure mode of: a) greased fine TR; b) greased coarse TR; and c) non-greased fine TR

In the second stage, two shallow T-girder specimens were made as shown in Figure 5.6 to simulate the top portion of a bridge I-girder. In each specimen, a 1.25 in. diameter TR with greased fine threads (7 threads per inch) and a structural washer and nut was embedded in the center of the specimen. Figure 5.7 shows a photo of the specimen prior to casting the concrete. A 10,000 psi SCC was used to make the two specimen to match the concrete strength recently used in bridge girders. Figure 5.8 shows the pullout test setup for the two specimen.

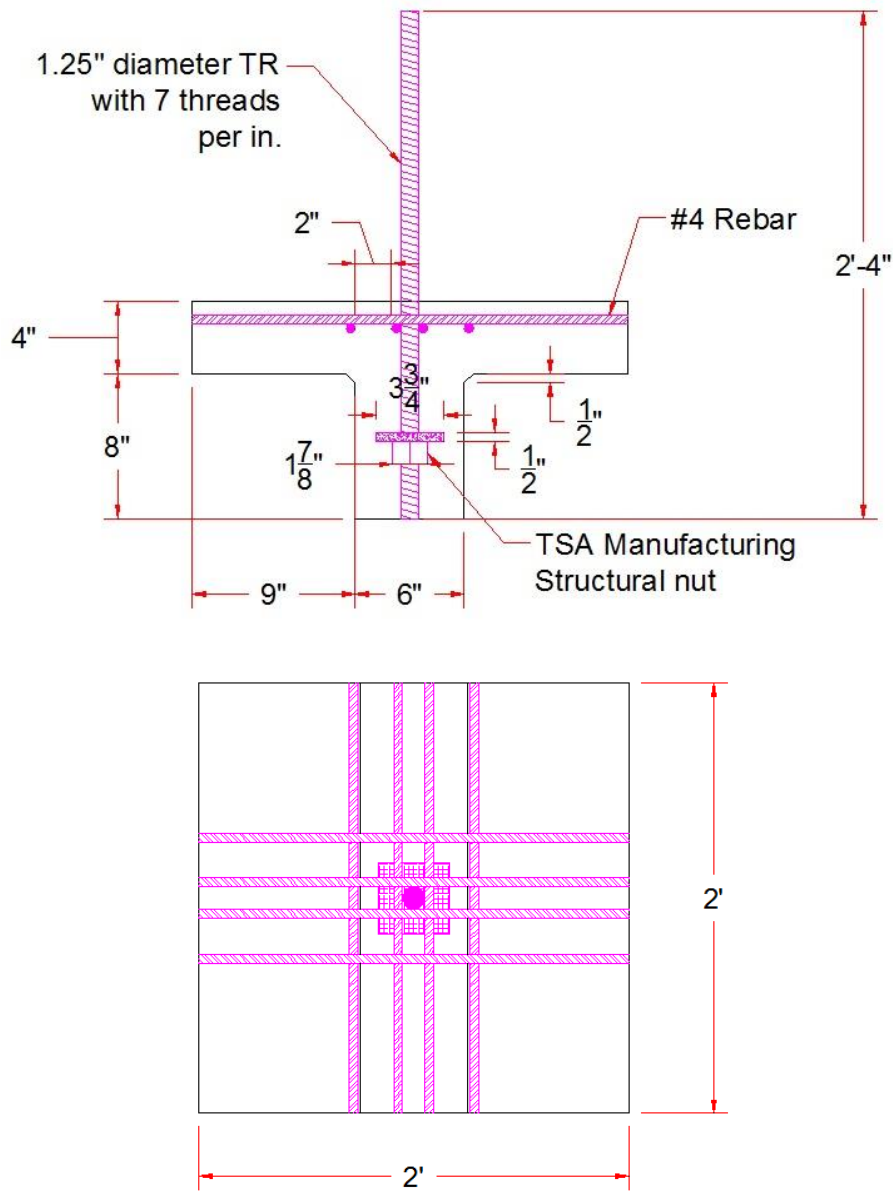

Figure 5.6: Plan and elevation views of the shallow T-girder specimen



Figure 5.7: Forming and reinforcement of shallow T-girder specimens



Figure 5.8: Pullout test setup of shallow T-girder specimens

Figure 5.9 plots the pullout test results of the two specimens (A and B). Although these results are significantly higher than those obtained from the previous stage of testing, none of the two TRs was ruptured. The TR in specimen B was fully developed as it reached the yield strength (at a load of 102,000 lbs), while the TR in specimen A was very close to the yield strength but did not reach it. Both specimens experienced severe cracking starting at the bottom of the web and propagating upward and spalling the concrete around the washer and nut as shown in Figure 5.10. This is primarily due to the lack of reinforcement of the shallow web. This problem was addressed in the third stage of testing as a deeper reinforced web is used.

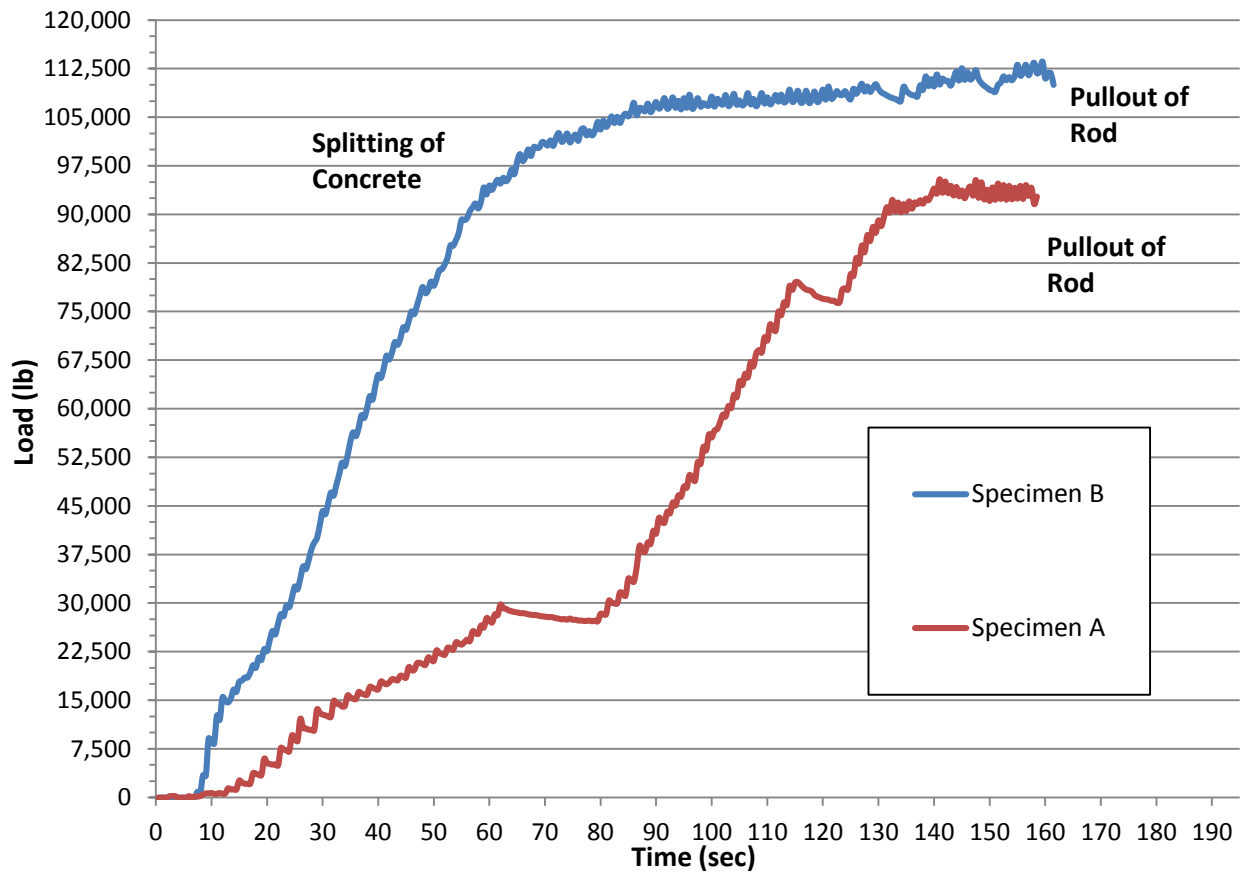

Figure 5.9: Pullout test results of the two shallow T-girder specimens



Figure 5.10: Failure modes of shallow T-girder specimens A (top) and B (bottom)

In the third stage, two deep T-girder specimens were made as shown in Figure 5.11 to simulate the upper half a bridge I-girder. In each specimen, a 1.25 in. diameter TR with greased fine threads (7 threads per inch) and a structural washer and nut was embedded in the center of the specimen. Figure 5.11 also shows the web reinforcement used in the specimens, which simulates typical shear reinforcement of bridge girders in addition to U bars around the TR to control cracking. Figure 5.12 shows a photo of the specimen prior to casting the concrete. A 7,000 psi SCC was used to make the two specimen to match the concrete strength of the Kearney East Bypass bridge girders. Figure 5.13 shows the pullout test setup for the two specimens A and B.

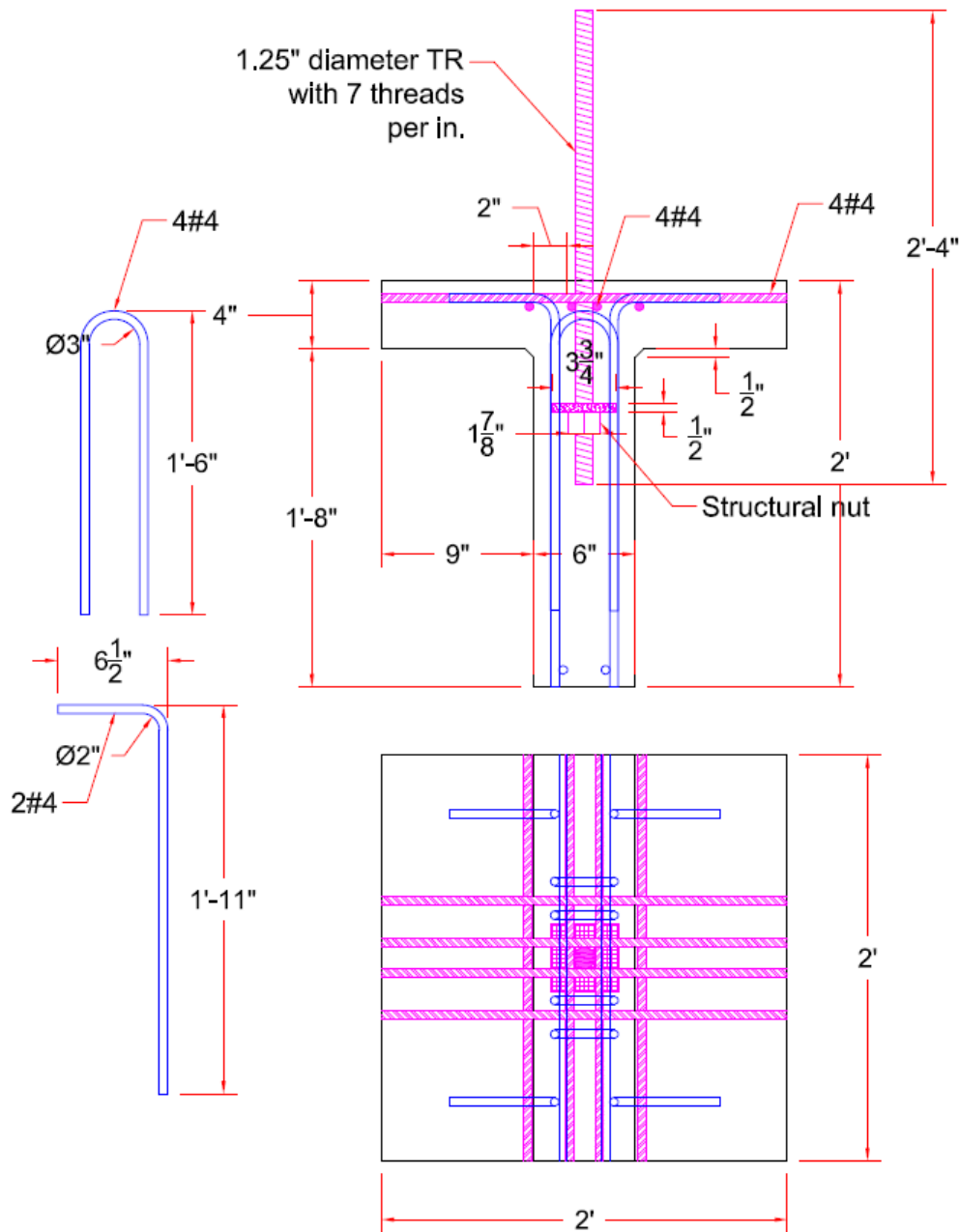

Figure 5.11: Plan and elevation views of the deep T-girder specimen



Figure 5.12: Forming and reinforcement of deep T-girder specimens



Figure 5.13: Pullout test setup of deep T-girder specimens

Figure 5.14 plots the pullout test results of the two specimens (A and B). These results are higher than those obtained from the previous stage of testing as the two TRs exceeded their yield strength. The TR in specimen B was ruptured with no visible cracking in the web, while the TR in specimen A cracked and crushed the web concrete after yielding as shown in Figure 5.15. The performance of the two specimens was considered satisfactory as the TR were fully developed under ultimate load (102,000 lbs) and the specimens did not crack under service loads (58,000 lb). However, to eliminate the crushing of the concrete occurred in specimen A, it was proposed to use anchor bars welded to the washer. These anchor bars will transfer the pullout force by bond along their length, which significantly reduce the bearing on the concrete that might cause cracking and crushing. To evaluate the performance of the proposed detail, one additional deep T-girder specimen was fabricated similar to the two specimens presented earlier with one exception, which is the use of 2 #6 bars welded to ½” plate washer as shown in Figure 5.16. This specimen was tested similar to specimen A and B as shown in Figure 5.13. The TR reached the yield strength and was completely ruptured as shown in Figure 5.17 with no visible cracking or damage to the surrounding concrete. Figure 5.18 plots the pullout test results, while Figure 5.19 plots the stress-strain diagram for the 1.25 in. diameter threaded rods used in these experiments. These rods have UNC thread diameter of 1 ¼” - 7 and they are ASTM A193 Grade B7 ($f_y = 105$ ksi, $f_u = 125$ ksi) with net area of 0.97 in.²

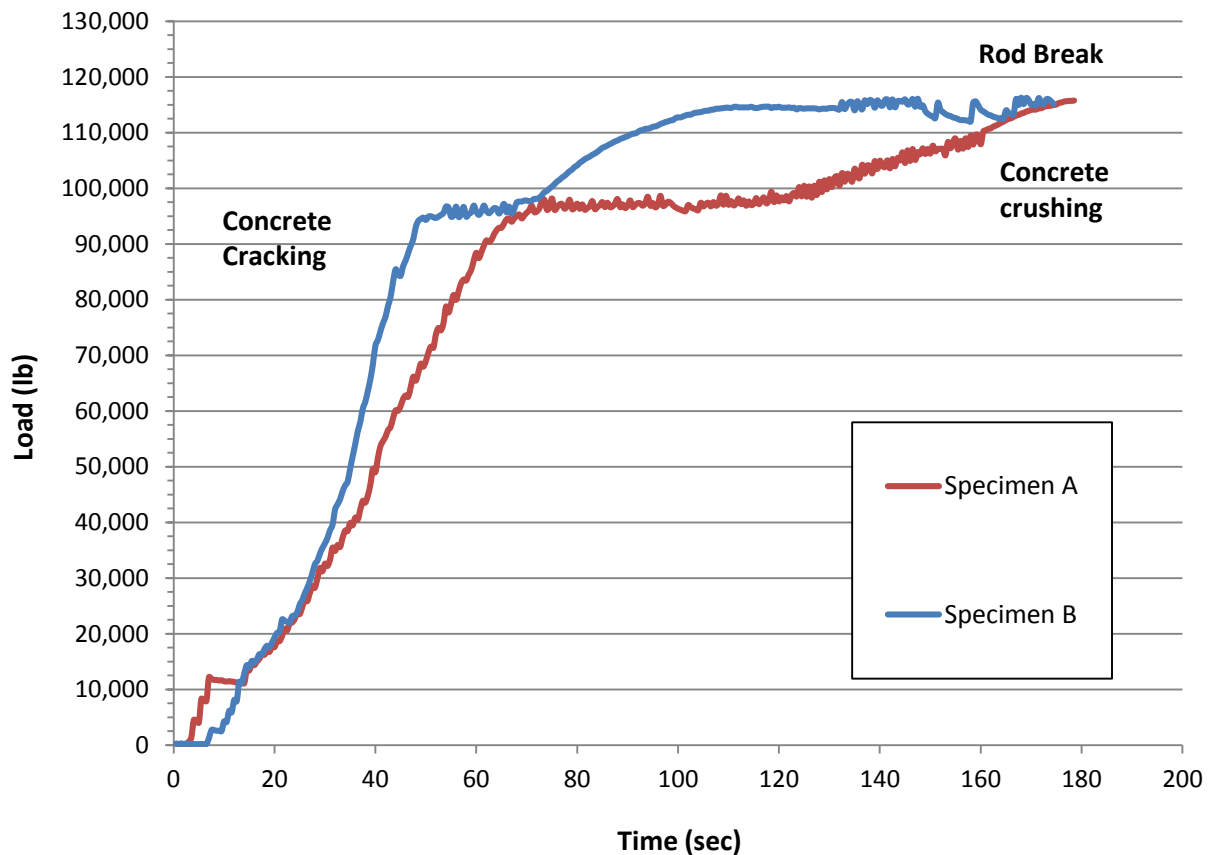

Figure 5.14: Pullout test results of the two deep T-girder specimens



Figure 5.15: Failure modes of deep T-girder specimens A (top) and B (bottom)

1.25" diameter greased threaded rod with heavy HEX nut welded to plate

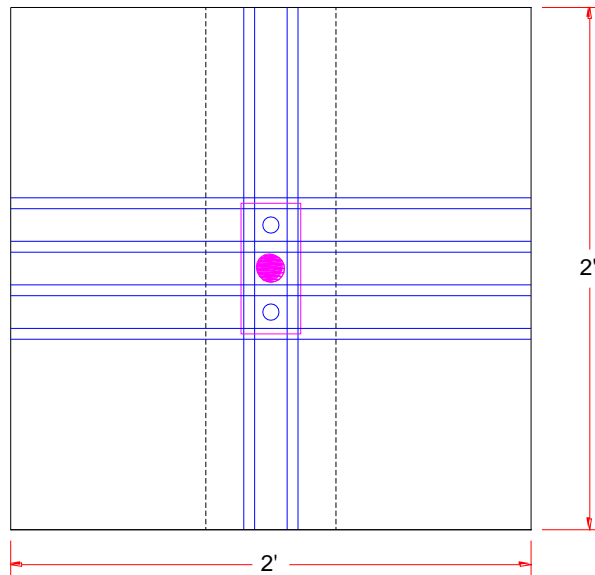
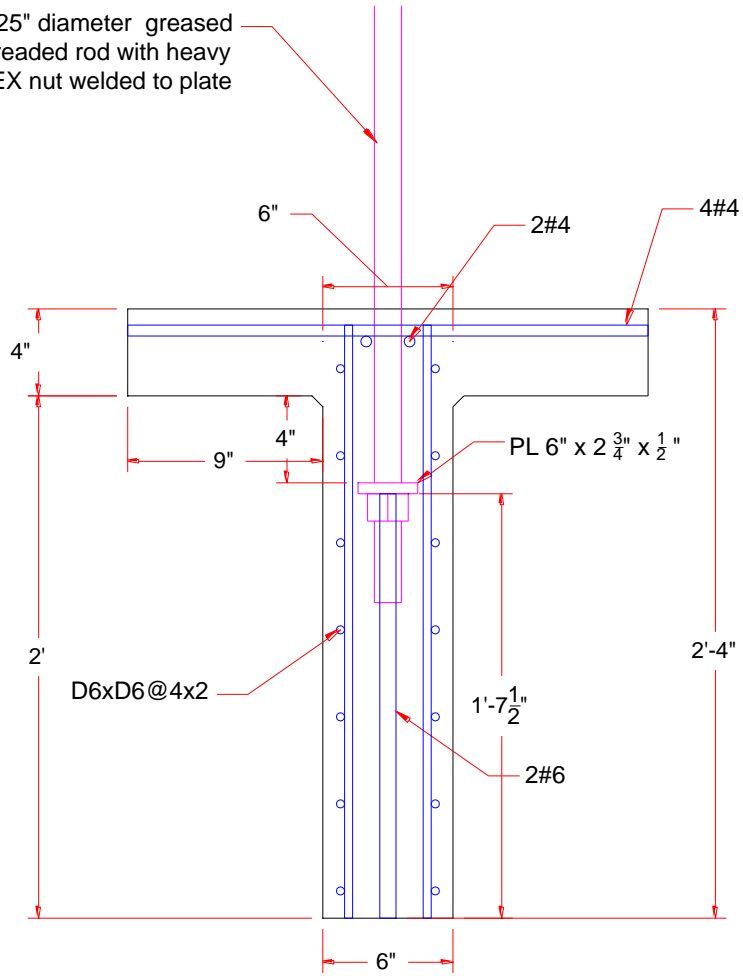



Figure 5.16: Deep T-girder specimen with anchor bars welded to the washer plate



Figure 5.17: Rupture of the TR

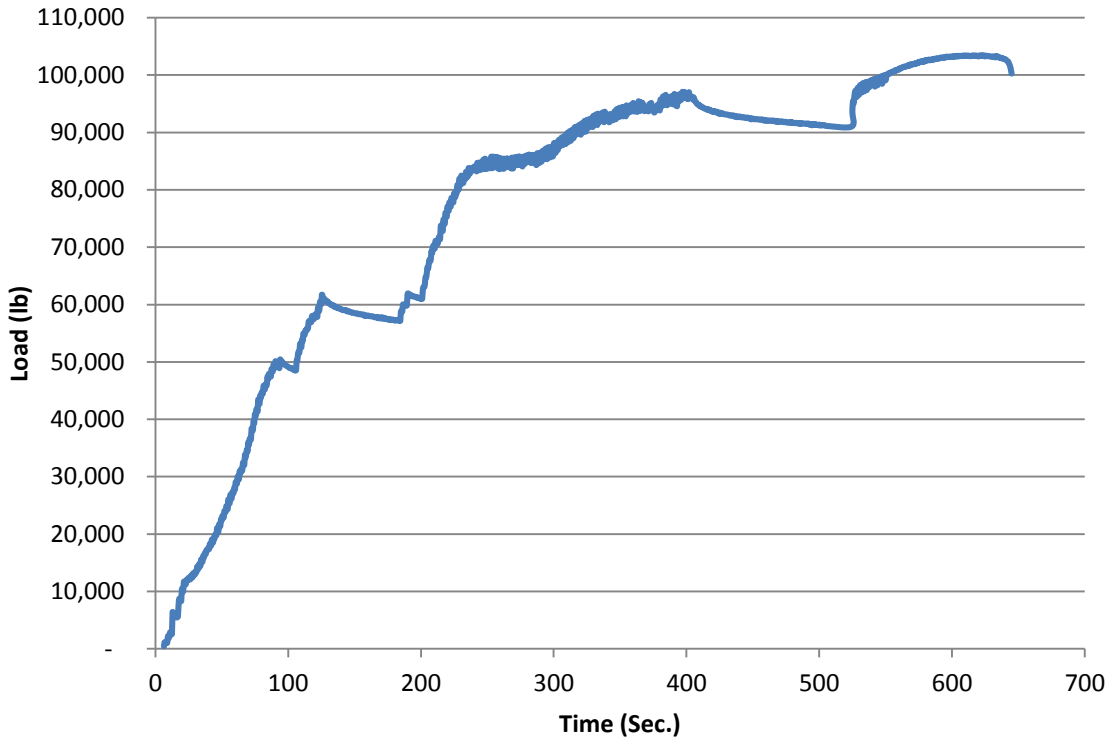

Figure 5.18: Pullout test results of a TR with anchor bars welded to the washer plate

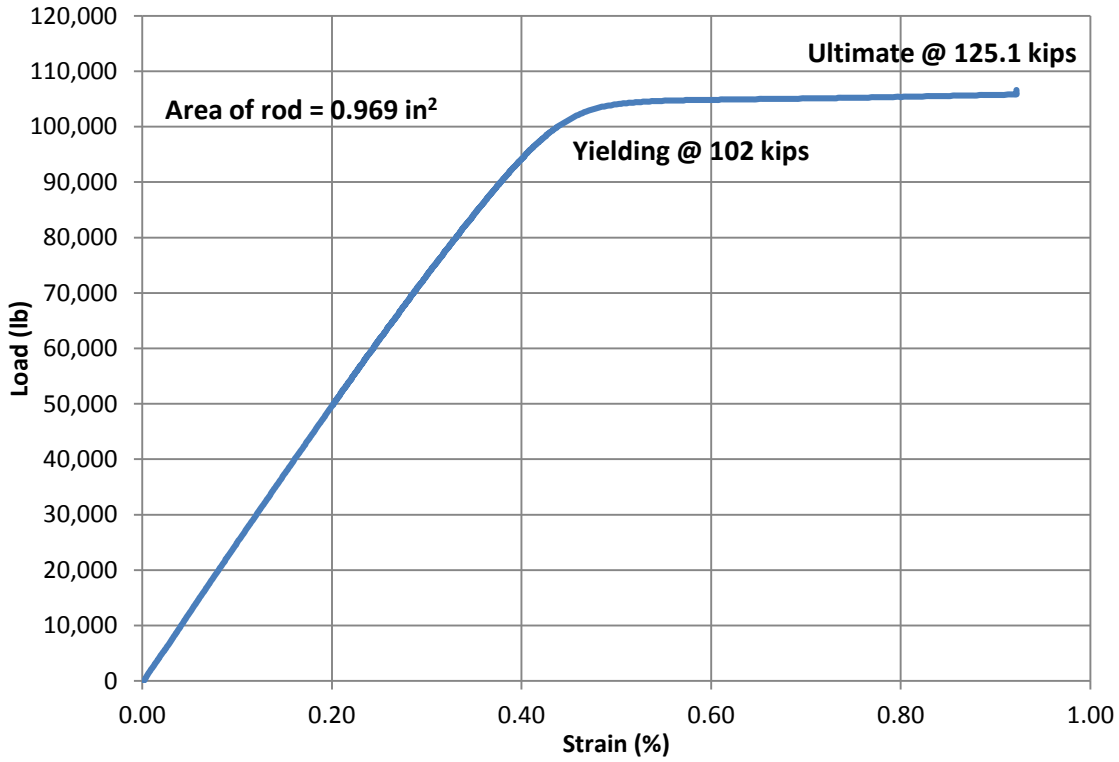

Figure 5.19: Stress-strain diagram of 1.25 in. diameter Grade B7 TR

5.2 Deck Pullout Testing

The purpose of this testing was to design the precast deck shear pockets and determine the type of grout/concrete required to achieve the required pullout capacity for the TR while considering the economy and ease of fabrication and construction. Testing was conducted on three stages:

- 1) Pullout from foam formed pockets filled with concrete and grout (10-24-2012);
- 2) Pullout from HSS and wood formed pockets filled with grout (11-29-2012); and
- 3) Pullout from HSS and metal sheet formed pockets filled with concrete (02-14-2013).

In the first stage of testing, two specimens that simulate precast deck panels were made. Each specimen was 3 ft x 3 ft x 8 in. as shown in Figure 5.20. A 5.5 in. deep pocket was formed in the middle of each specimen using a foam blockout as shown in Figure 5.21. The pocket is 8 in. long and has a wedged width that is 8 in. at the top and 10 in. at the bottom. The pocket was reinforced using 1#4 on each side at the top and 1#4 on each side at the bottom in addition to conventional deck reinforcement.

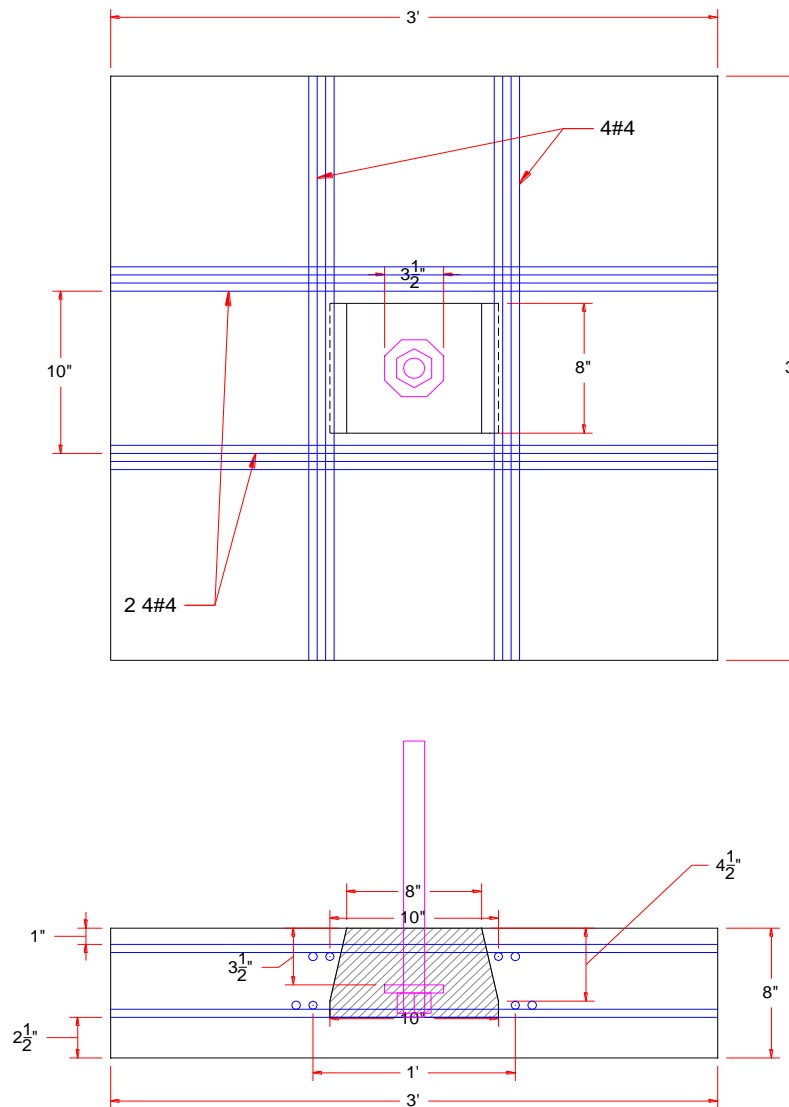

Figure 5.20: Plan and section views of deck specimens with foam-formed pockets



Figure 5.21: Foam blockout used to form the pocket in deck specimens

The pocket of one specimen was filled using a highly flowable non-shrink cementitious grout (Master flow 928) as shown in Figure 5.22, while the pocket of the other specimen was filled using a self-consolidating concrete (SCC) after installing the 1.25 in. diameter TR with a washer and nut. Pullout testing was conducted as shown in Figure 5.23 when the grout strength reached 8.9 ksi and the SCC strength reached 9.8 ksi. The two specimens had the same failure mode, which is pulling out a concrete cone as shown in Figure 5.24. Pullout test results shown in Figure 5.25 indicate that the SCC-filled pocket (24,897 lb) had slightly better performance than the grout-filled pocket (23,458 lb). However, both pockets did not have adequate performance as their pullout capacity was way lower than the required capacity, which is $60 \text{ ksi} \times 0.969 \text{ (TR net cross section area)} = 58,000 \text{ lb}$.



Figure 5.22: Filling the pockets using commercial grouts



Figure 5.23: Pullout test setup



Figure 5.24: Pullout failure mode

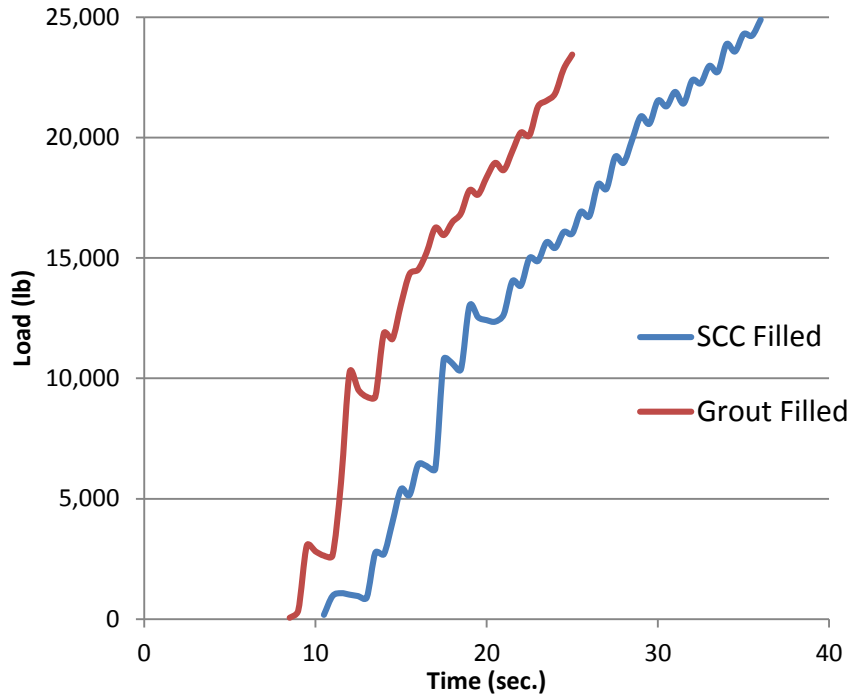

Figure 5.25: Pullout test results

In the second stage of testing, two specimens that simulate precast deck panels were made. Each specimen was 6 ft x 3 ft x 8 in. and had two 5.5 in. deep pockets that centered in the specimen. The pockets in one specimen were formed using steel HSS 8" x 8" x 1/4" sections with welded end plates as shown in Figure 5.26. The pockets in the other specimen were formed using wooden boxes with shear keys as shown in Figure 5.27. Each HSS-formed pocket was anchored using 2#5 bent bars welded to two sides of the HSS section to anchor it to the surrounding concrete. Each wood-formed pocket was anchored using 2#4 bars placed on each side of the shear key at the top. Additional #4 bars were used to represent the conventional deck reinforcement. Figure 5.28 shows one of each pocket type prior to grouting. The two HSS-formed pockets were filled using a highly flowable non-shrink cementitious grout (Masterflow 928), while the two wood-formed pockets with shear keys were filled using a flowable non-shrink non-cementitious grout (Masterflow Set 45). Pullout test was conducted using the same setup used in the previous stage (Figure 5.23). Testing was conducted when the cube compressive strength of the Set 45 grout was 5.02 ksi, and of the 928 grout was 9.88 ksi. Figure 5.29 plots the results of the four pullout tests and Figure 5.30 shows the failure mode of each type of pockets. These results indicated that confinement effects of the HSS significantly improved the pullout capacity of the pocket as they achieved an average pullout capacity of 40,600 lbs versus 26,700 lbs for the pockets with shear key. The failure mode of the HSS-formed pockets was the shearing of the 2#5 anchor bars, which indicated that the pullout capacity could have been even higher if the steel tube was better anchored to the concrete. On the other hand, adding a shear key to the pockets did not significantly improve the pullout capacity over those achieved in the previous stage while being more complicated in fabrication. It should be noted that the higher compressive strength of the 928 grout had also contributed to the higher pullout capacity of the HSS-formed pockets.

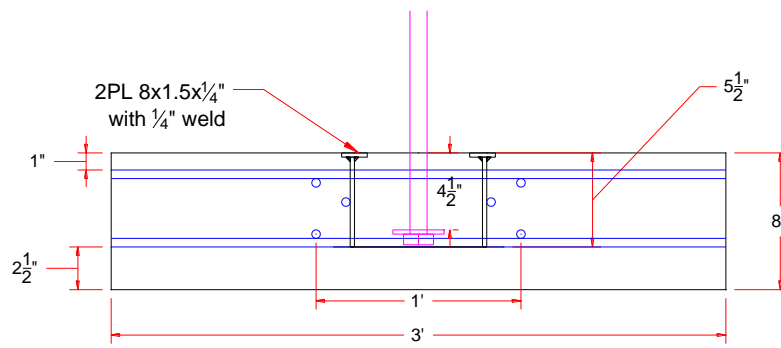
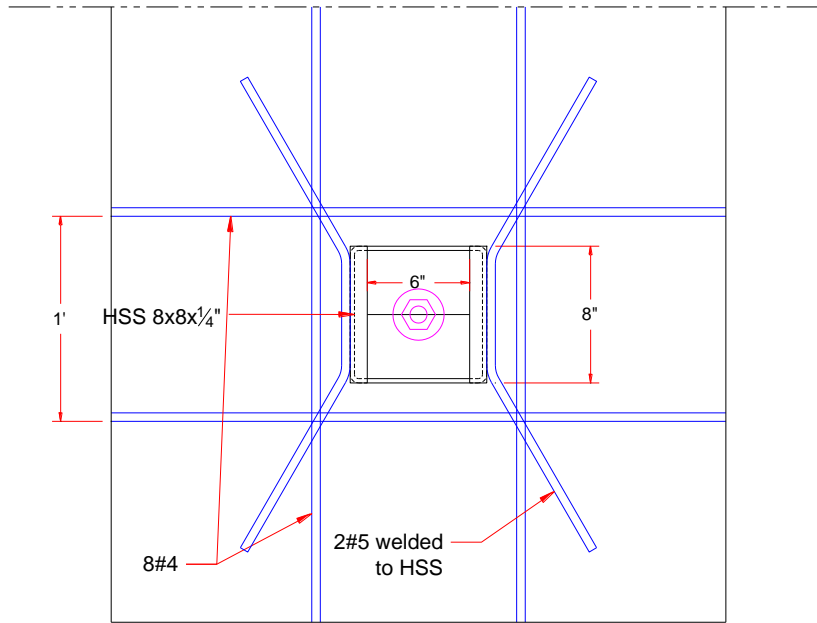

Figure 5.26: Steel HSS-formed pocket with welded end plates

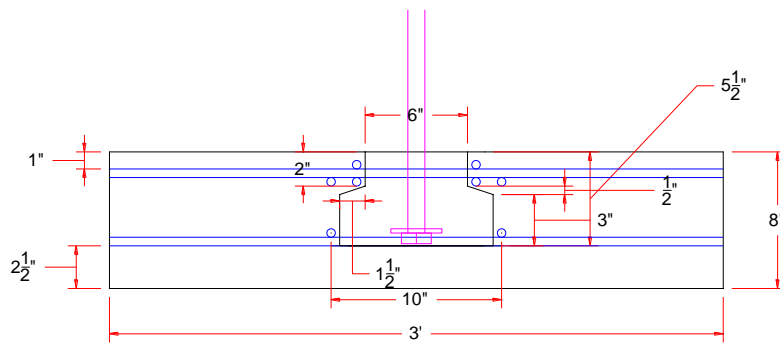
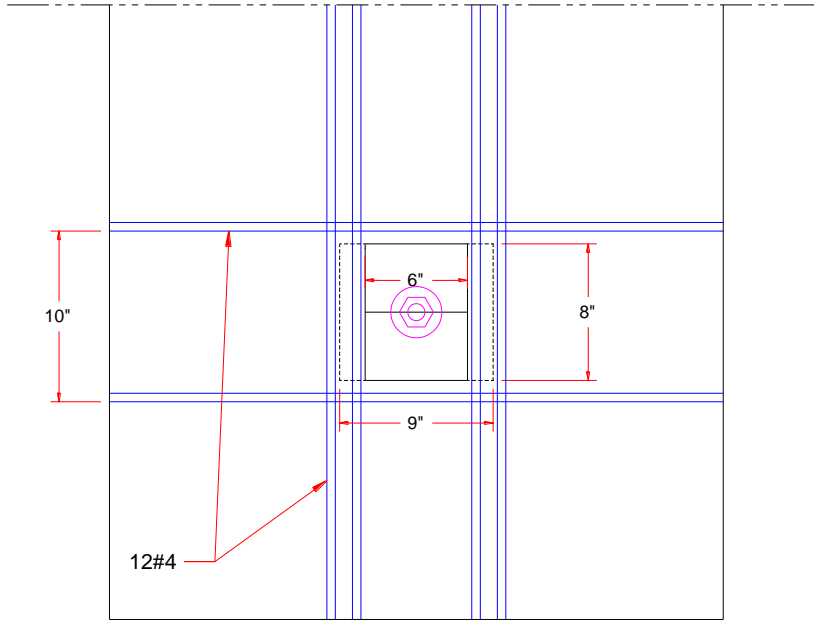

Figure 5.27: Wood-formed pocket with shear key



Figure 5.28: The two pockets prior to grouting

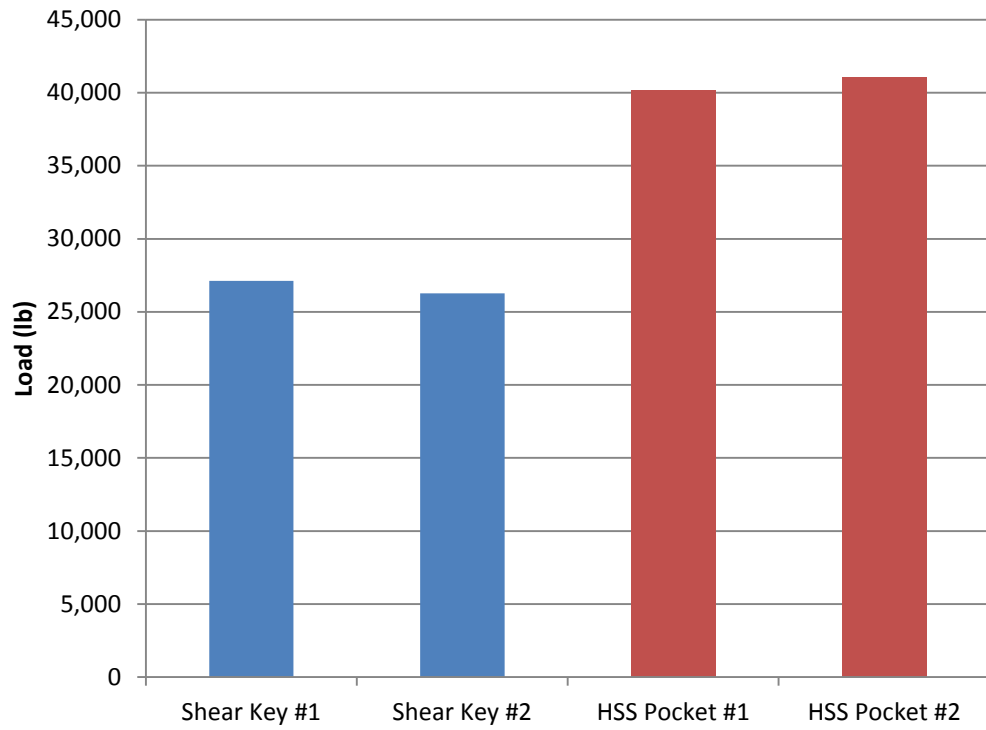

Figure 5.29: Pullout test setup



Figure 5.30: Pullout failure mode of HSS-formed pocket (left) and shear-keyed pocket (right)

In the third stage of testing, two specimens that simulate precast deck panels were made. Each specimen was 6 ft x 3 ft x 8 in. and had two 5.5 in. deep pockets that centered in the specimen. The pockets in one specimen were formed using steel HSS 8" x 8" x 1/4" sections with four 6 in. long #5 bars welded end plates as shown in Figure 5.31. The pockets in the other specimen were formed using metal sheets that are cut and stapled to form a wedged pocket as shown in Figure 5.32. Each HSS-formed pocket was anchored using 4#5 straight bars welded to the four sides of the HSS section to anchor it to the surrounding concrete. One of metal sheet formed pocket was reinforced using 4#6 hat bars placed parallel to the four sides, while the other metal sheet formed pocket was reinforced using three 3/4" studs welded to 1/2" thick plate placed on each side of the pocket as shown in Figure 5.33. Additional #4 bars were used to represent the conventional deck reinforcement. Figure 5.33 shows the four pockets in the form and the surrounding reinforcement prior to pouring the deck concrete. Pullout test was conducted using the same setup used in the first stage (Figure 5.23). Testing was conducted when the compressive strength of the SCC was 7.1 ksi, while the compressive strength of the deck concrete reached 10.6 ksi. Figure 5.34 plots the results of the four pullout tests and Figure 5.35 shows the failure mode of each pockets. These results indicated that confinement effects of the HSS significantly improved the pullout capacity of the pocket as they achieved an average pullout capacity of 53,755 lbs versus 41,306 lbs for the metal sheet formed pockets. The failure mode of the HSS-formed pockets was the spalling of the deck concrete above the anchor bars, which indicated that the pullout capacity will be even higher when this is used in an actual deck (upside down). On the other hand, adding hat bars or shear studs to the pockets did slightly improve the pullout capacity over those achieved in the previous stages due to their confinement effects. However, the fabrication and reinforcement of this type of pockets was found to be costly and time-consuming and, thus, was not recommended for this application.

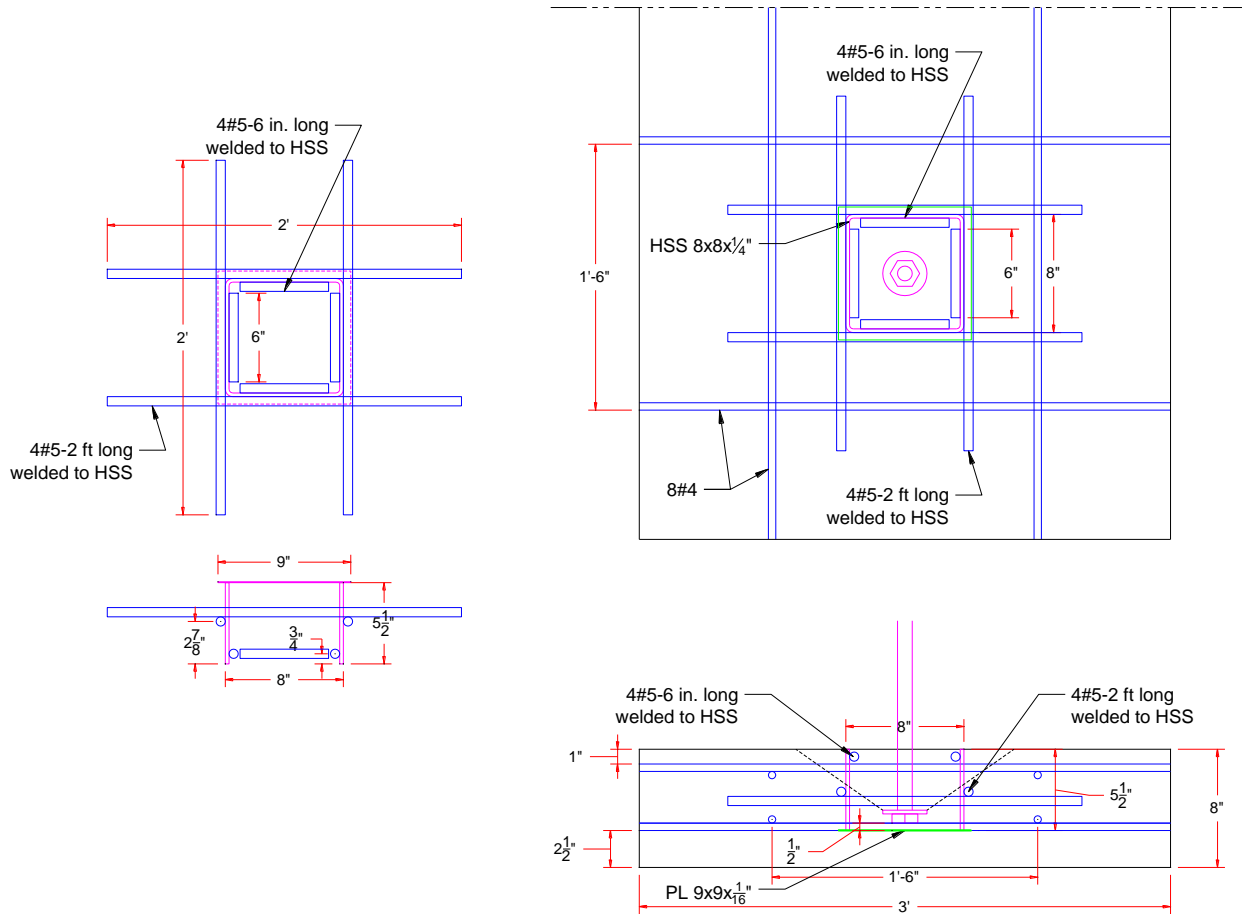

Figure 5.31: Plan and section views of HSS-formed pocket

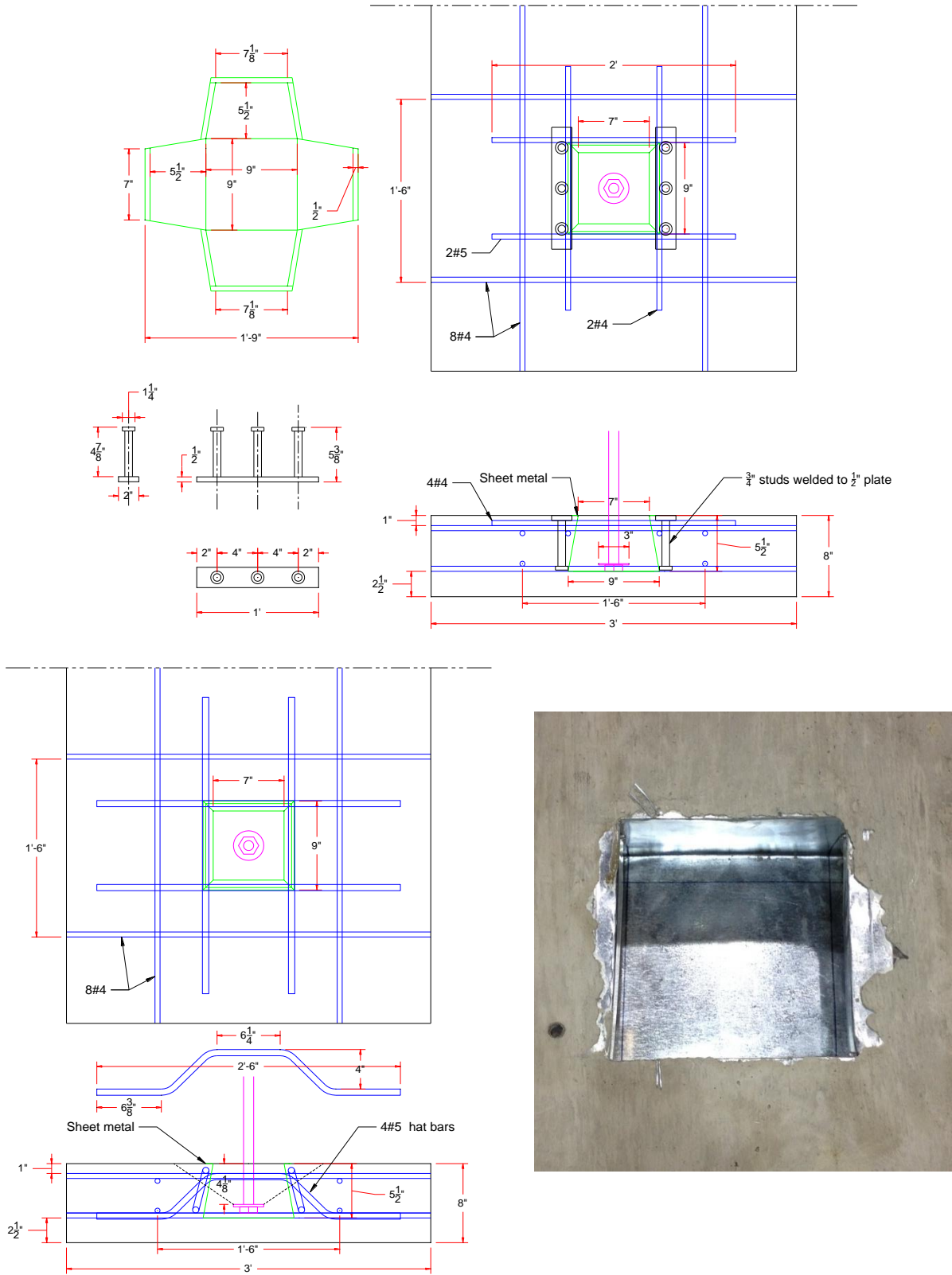

Figure 5.32: Plan and section views of metal sheet-formed pocket

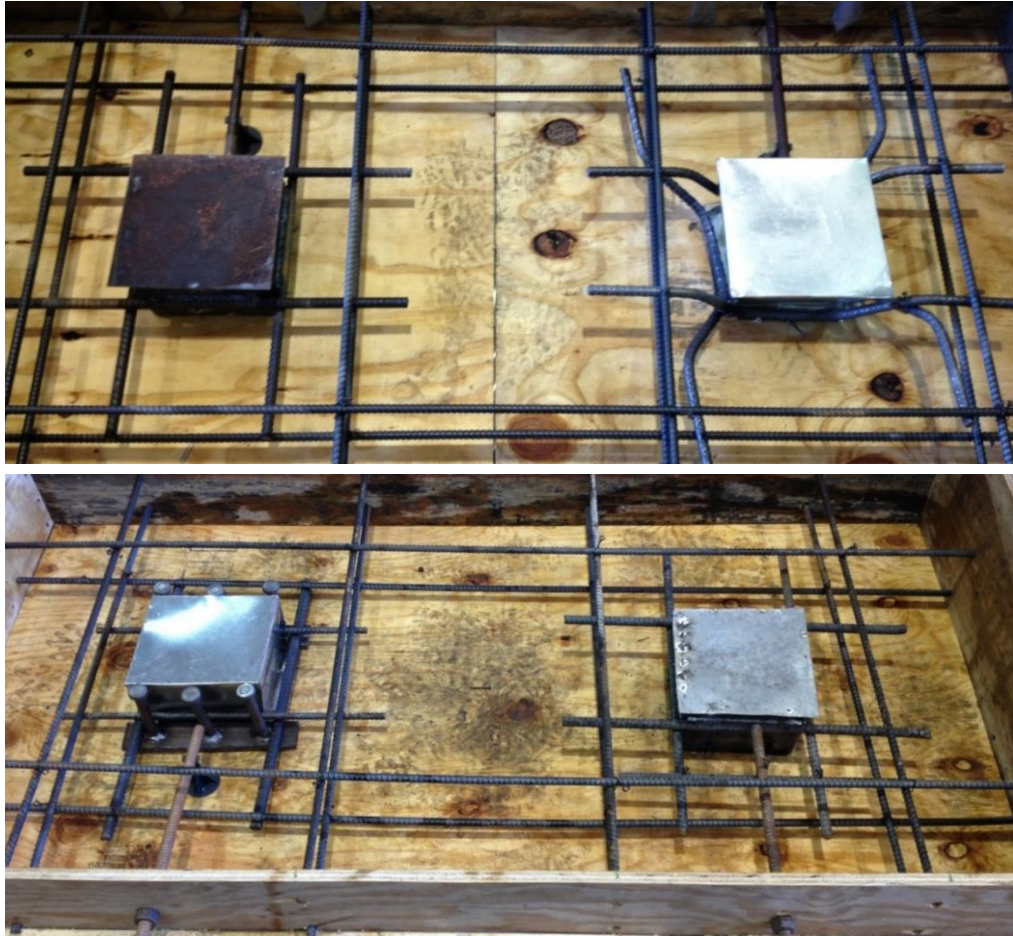

Figure 5.33: Forming and reinforcement of the two specimens

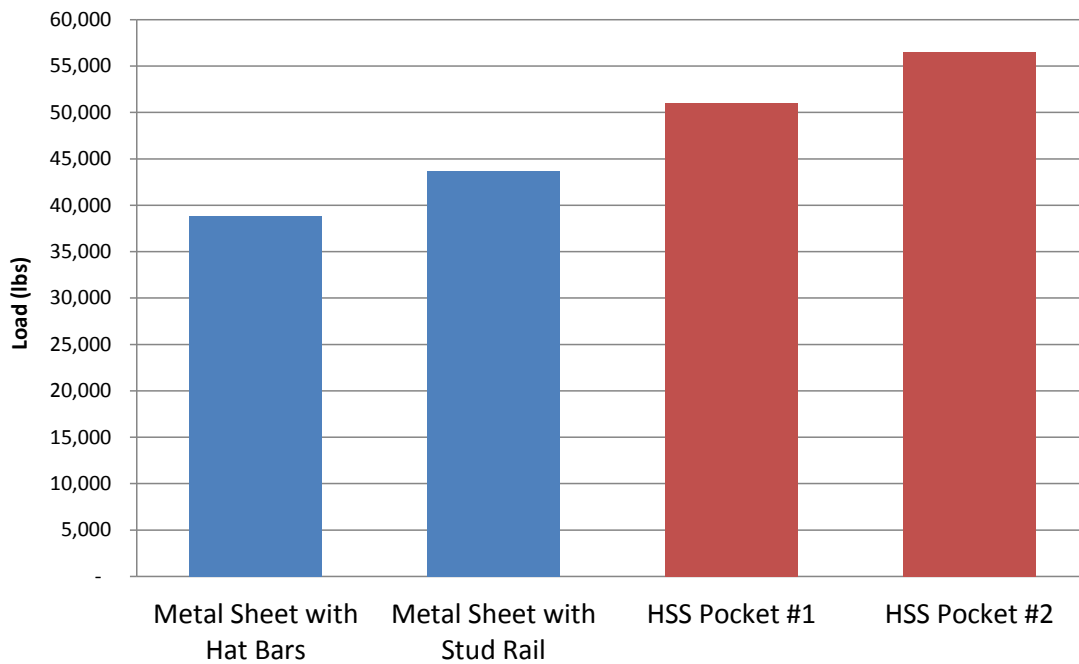

Figure 5.34: Pullout test results of the four pockets

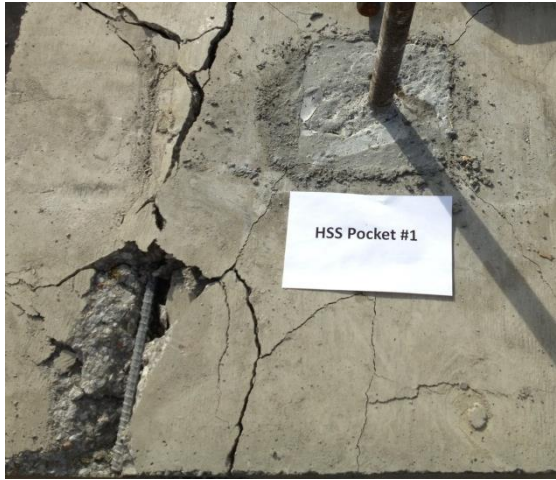

Figure 5.35: Pullout failure modes of the four pockets

6 FULL-SCALE EXPERIMENTAL INVESTIGATION

6.1 Panel Lifting Testing

A full-scale bridge deck panel was fabricated by Concrete Industries, Inc. (CI) on April 25, 2013 to demonstrate panel lifting and evaluate the performance of the proposed lifting inserts attached to type A pockets. Figure 6.1 shows the dimensions and detailing of the fabricated panel. The proportions of the concrete mixture used in panel fabrication are shown in Table 6.1. The panel has an average 4-day release strength of 6,765 psi and an average 28-day strength of 9,293 psi as shown in Figure 6.2. It should be noted that the NUDECK panels of the Kearney East Bypass should be fabricated using the approved 47BD concrete mixture and should have a release strength and 28-day strength are 3,500 psi and 6,000 psi, respectively.

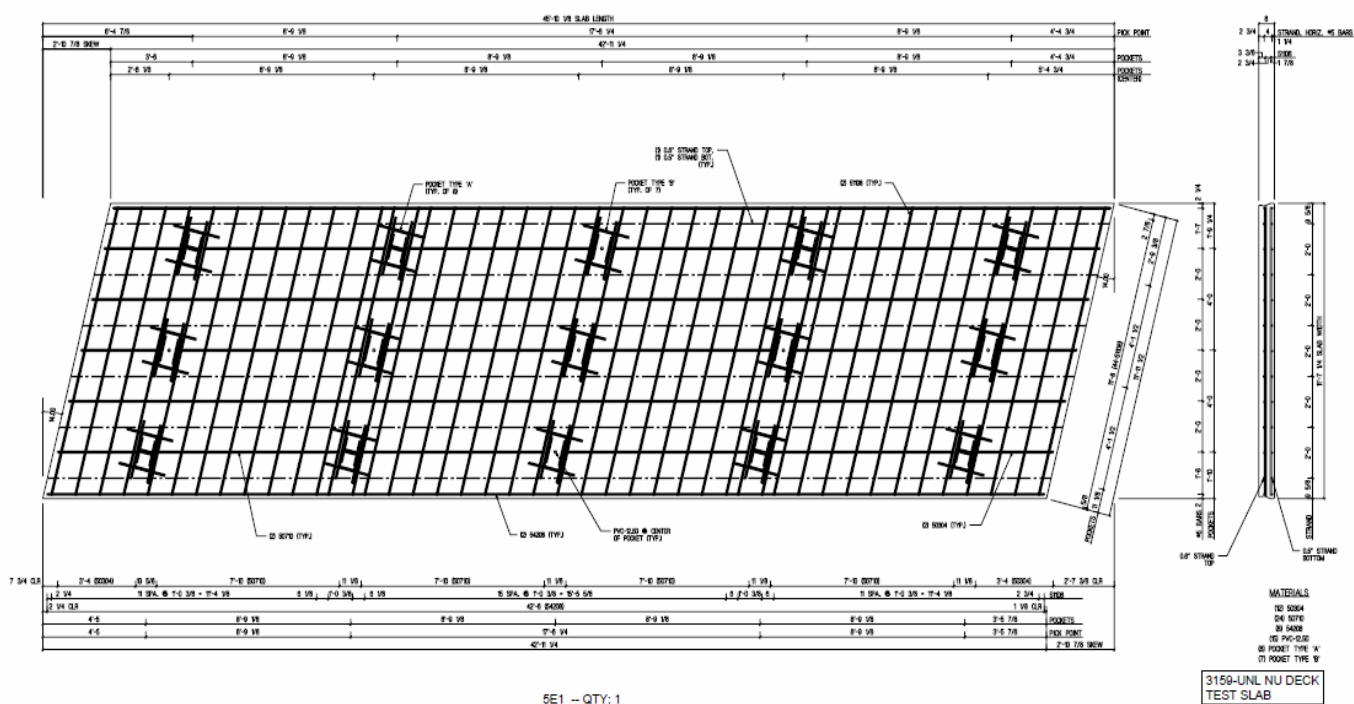

Figure 6.1: Dimensions and detailing of the fabricated demonstration panel

Table 6.1: Mixture proportions used in the demonstration deck panel

GENERAL TESTING LABORATORIES

TELEPHONE (402)434-1891
 FAX (402)434-2161

P. O. BOX 29529
 LINCOLN, NEBRASKA 68529

CONCRETE INDUSTRIES
 STRUCTURAL DIVISION
 CONCRETE MIX DESIGN FOR: **STANDARD GRAY CONCRETE**
April 25, 2013

Mix # 9382

MATERIAL	WT/CU YD	SUPPLIER
Portland Cement Type III, Gray	632 lb	Lafarge Cement Kansas City, MO
Fly Ash, Class C	100 lb	Nebraska Ash Lincoln, NE
1/2" Limestone (SSD)	1343 lb	Kerford Limestone Weeping Water, NE
C33 Sand (SSD)	1433 lb	Western Sand & Gravel Ashland, NE
Total Water 0.399 w/c ratio	35.0 gal	Lincoln Water System Lincoln, NE
Air Entraining Admixture, MB-AE-90	4.5 ± 1.5%	Master Builders, Inc Cleveland, OH
Water Reducer, Retarder Pozzolith 300R	0 - 5 oz/cwt (As needed for Set Control)	Master Builders, Inc Cleveland, OH
High Range Water Reducer Glenium 3400	5-10 oz/cwt (As needed for Spread Control)	Master Builders, Inc Cleveland, OH

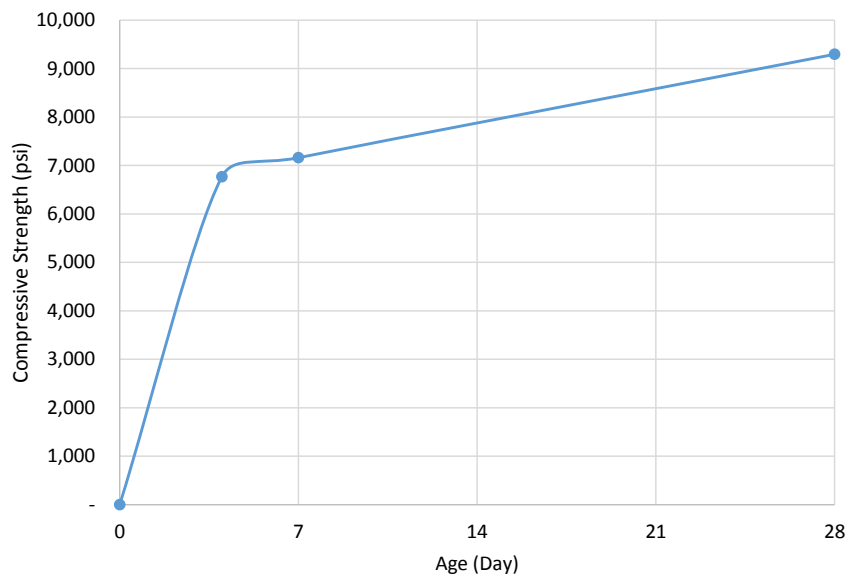

Figure 6.2: Compression strength of the concrete used in the deck demonstration panel

The full-scale demonstration panel has 8 lifting points (one lifting point at each pocket type A). The panel was analyzed as a continuous beam on four supports (every two lifting points represent one support) under its self-weight only. Based on the elastic analysis results, the maximum load per lifting insert was 8.5 kip. Design calculations for the lifting insert to carry a load of 8.5 kips and using a load factor of 4.0 is shown in Table 4.3. Also bending moment, shear force, and deflection diagrams of the panel during lifting is shown in Figure 4.4. Top and bottom fiber stresses at critical positive and negative moments sections were checked to ensure that the panel does not crack during handling and erection. The use of 0.6 in. diameter strands at the top and 0.5 in. diameter strands at the bottom resulted in no tension stresses at all in the panel during handling.

Prior to fabricating the full-scale demonstration deck panel at the precast plant, a small scale panel that is 4 ft x 3 ft x 8 in. with one pocket type A was fabricated at the UNL structural laboratory in Omaha to evaluate the lifting capacity of the proposed detail. Figure 6.3 show the specimen drawing and a photo of the specimen before casting concrete. It should be noted that the pocket used in this specimen has 1.5 in. deep plates instead of 2 in. deep plates required by the calculations shown in Table 4.3. The specimen was tested on March, 21, 2013 by pulling out a 3/4" diameter coil rod using a hydraulic jack as shown in Figure 6.4. Figure 6.5 shows the test results and the failure mode, which is the rupture of the lifting plates at a maximum load of 30 kips, which is 50% more than the calculated value for a 1.5 in. deep plates. Using 2 in. deep plates would result in significantly higher pullout capacity (approximately 50 kips) than the demand (34 kips).

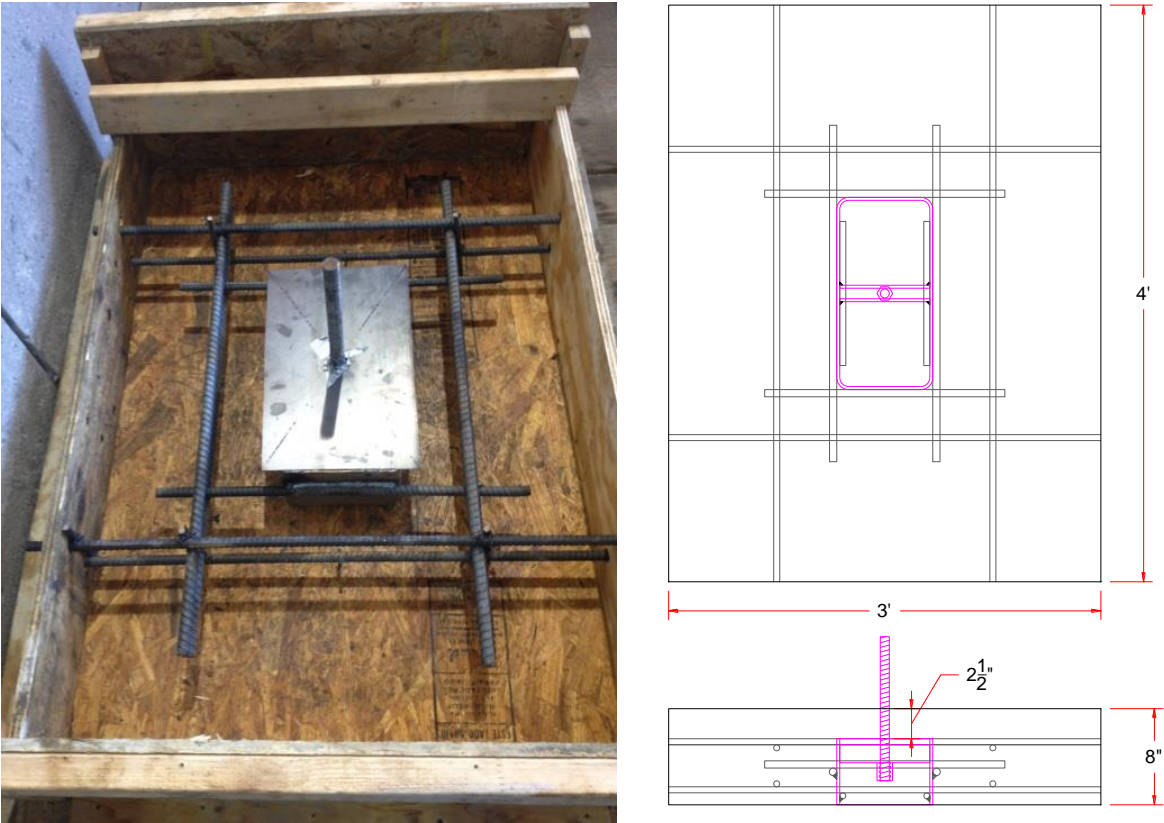

Figure 6.3: Pullout specimen dimensions and reinforcing details



Figure 6.4: Pullout test setup

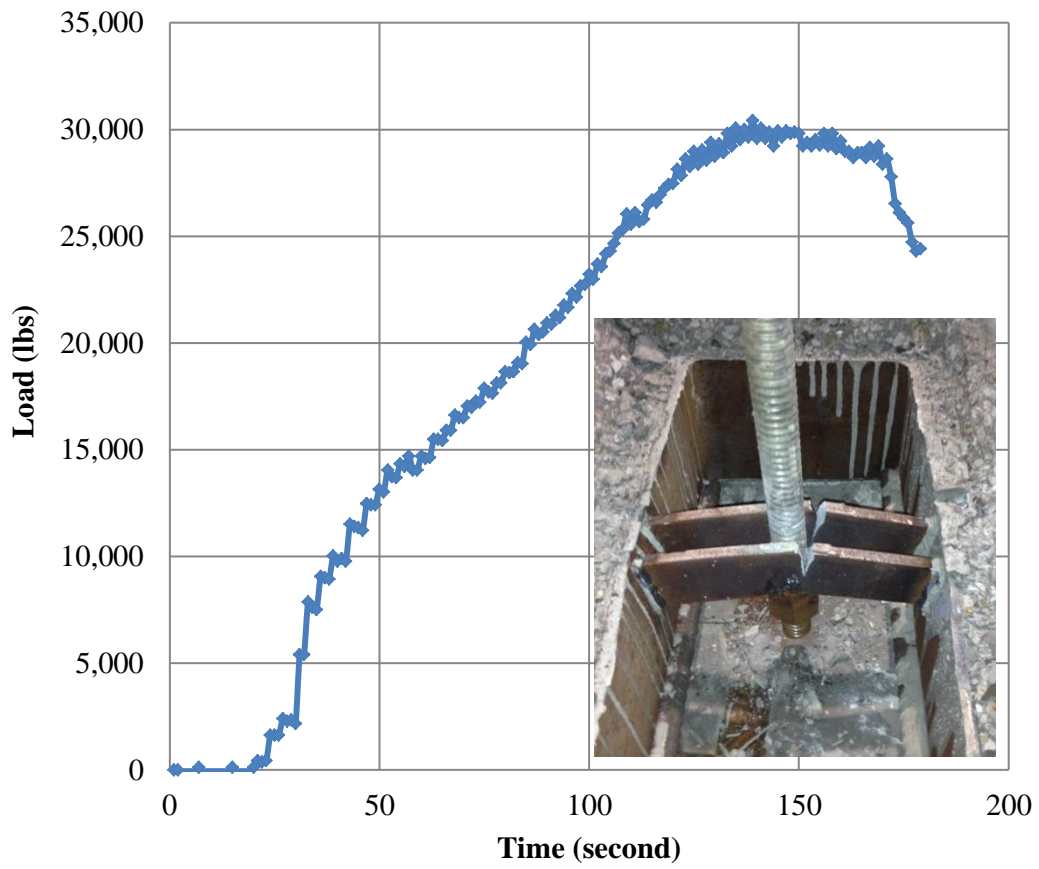

Figure 6.5: Test results and failure mode

The experimental investigation of the full-scale demonstrating panel was conducted by lifting the panel at the eight lifting inserts located in the shear pockets type A and visually inspecting the panel for cracking. This investigation was conducted at the precast yard of concrete Industries, Inc., Lincoln, NE on May 8, 2013 by precast staff under the supervision of NDOR bridge engineers and UNL researchers. Figure 6.6 shows the panel before lifting, spreader beam, and crane used in lifting the panel. Figure 6.7 shows tightening the coil nuts after placing the coil rod and swivel plate. For watching the video of the panel lifting, please use the following link: http://www.youtube.com/watch?v=Bx2p2_78fJs



Figure 6.6: Demonstration panel before lifting and the spreader beam



Figure 6.7: The coil rod with nuts and swivel plates used for panel lifting

Figure 6.8 shows the soffit of the demonstration panel while being lifted for inspection. The thorough visual inspection has indicated that no cracking or any type of damage has been observed at the top or bottom surface of the panel during or after lifting, which confirms the adequacy of the lifting insert design and the excellent performance and stiffness of the deck panel during handling



Figure 6.8: Photos of the soffit of the demonstration panel during lifting

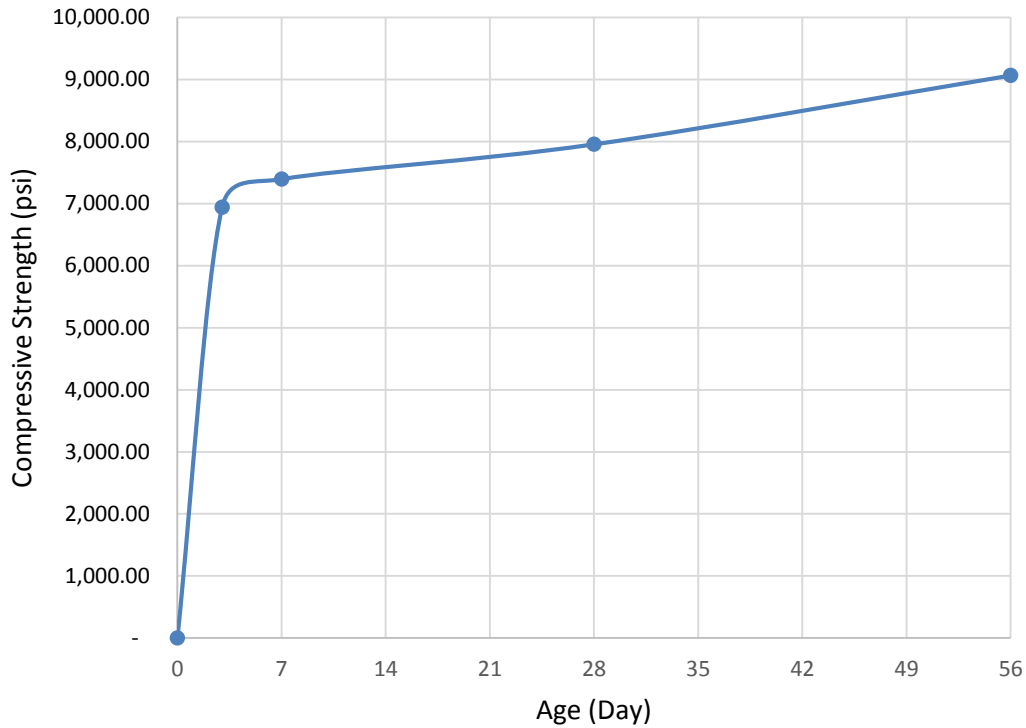

Figure 6.10: Girder concrete compressive strength vs. time.

A total of five precast concrete deck panels were needed to build the full-scale specimen: three typical panels and two end panels. The three typical panels were obtained by saw cutting the full-scale demonstration deck panel presented earlier as shown in Figure 6.11. The cutting resulted in three skewed panels that are 12 ft long and 7 ft 8.25 in. wide. Each panel has three pockets (two type A and one type B) at 4 ft spacing. Figure 6.12 show plan and sectional views of one of these panels as well as its reinforcement details. The two end panels were fabricated by Concrete Industries, Inc. using the same SCC mixture used for the demonstration panel (Table 6.1). Figure 6.13 show plan and sectional views of a typical panel as well as its reinforcement details. It should be noted that end panel specimens were not prestressed. Photos of panel cutting and post-tensioning anchor blocks and plates are shown in Appendix C.

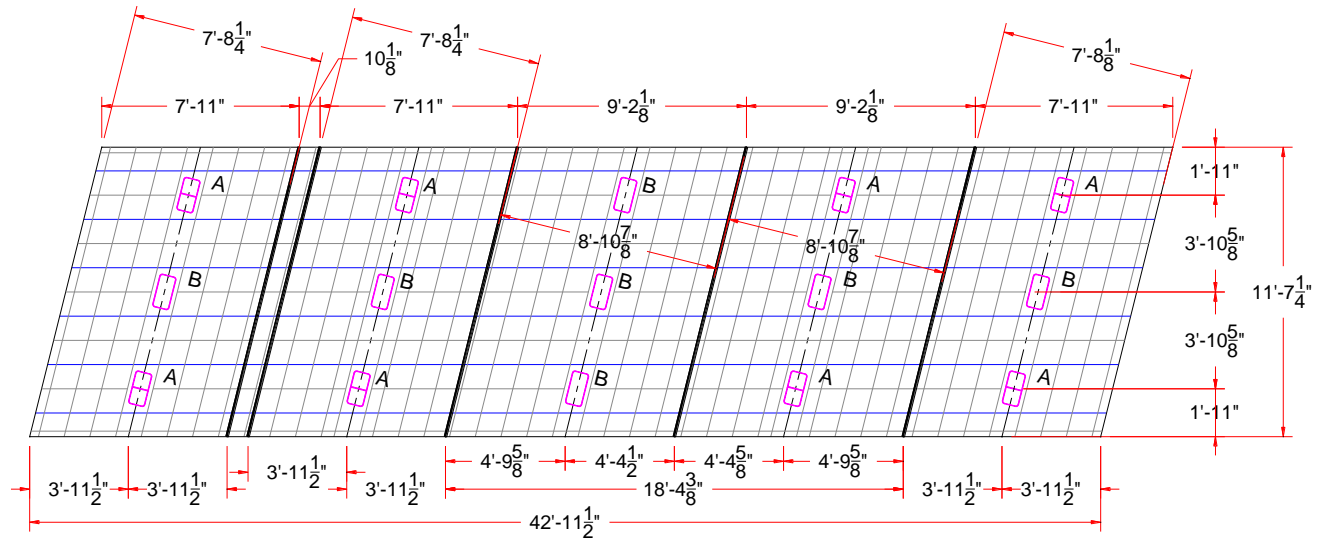

Figure 6.11: Layout of panel cutting

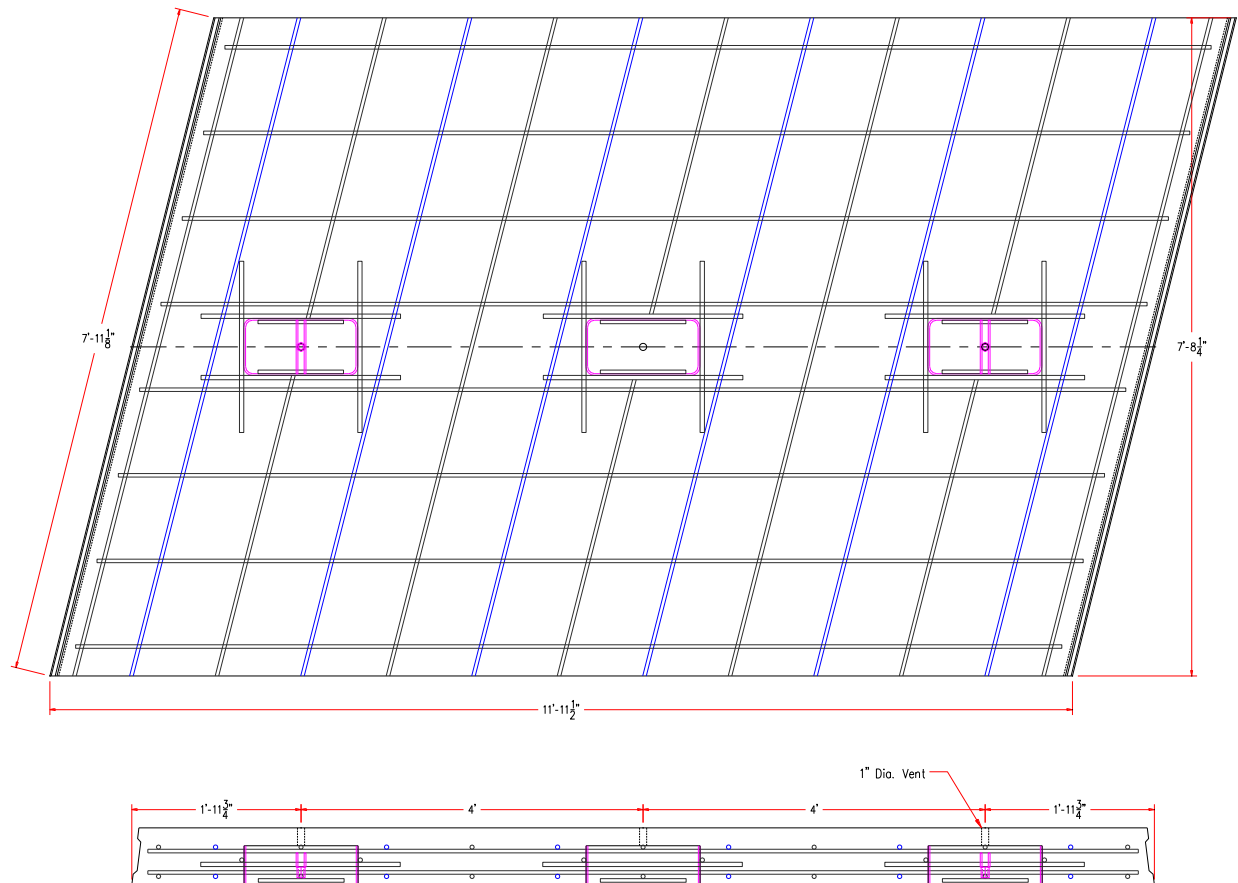

Figure 6.12: Dimensions and reinforcement of a typical panel specimen

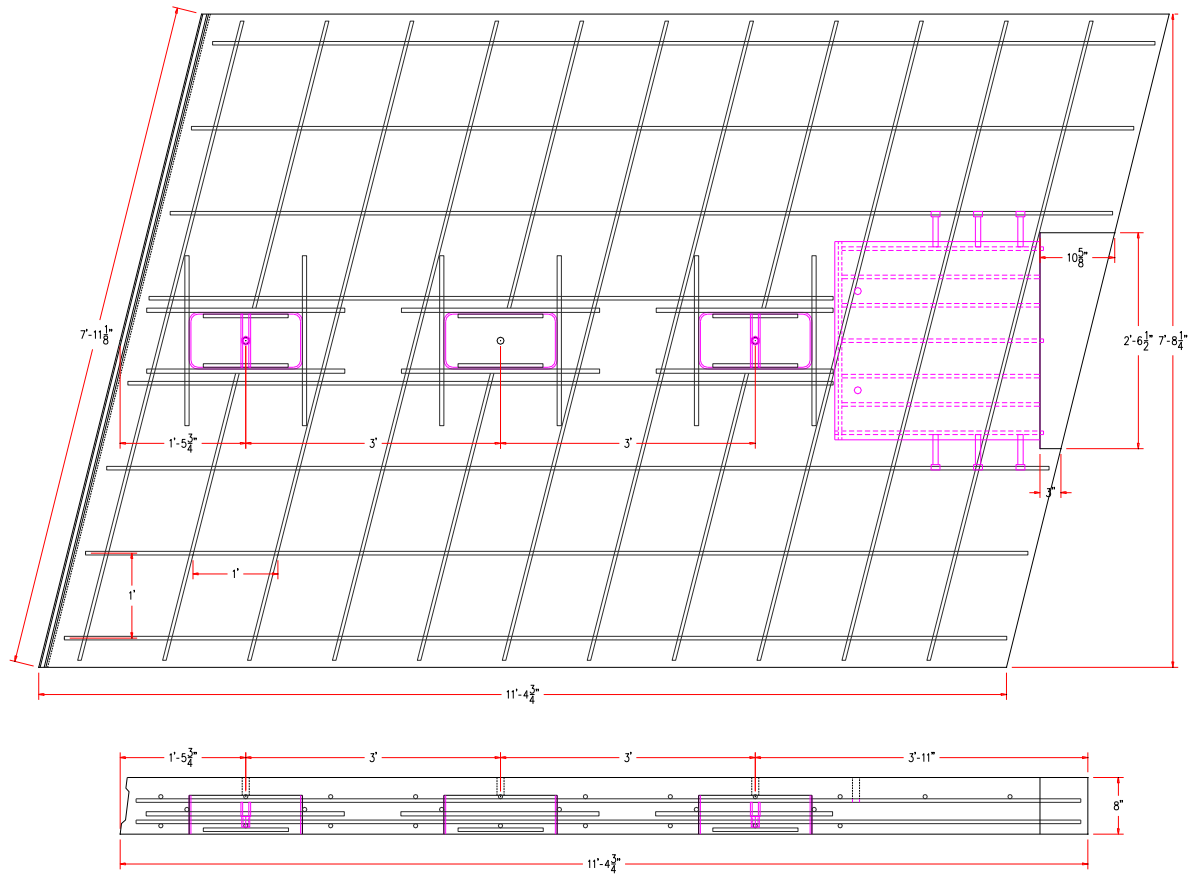

Figure 6.13: Dimensions and reinforcement of an end panel specimen

The NU900 girder specimen and the five deck panel specimens were shipped to UNL Structural Laboratory in Omaha for erection. Below are the steps followed in specimen erection for testing. Photos of these steps are shown in Appendix D.

1. Place the girder on roller supports located at the girder ends to create a simple span of 57 ft 10 in.
2. Lay down 12-0.6 in. diameter post-tensioning strands on the top flange and thread the ends through the deviators at girder ends. Strands were 4 ft longer than the girder.
3. Install steel bent plates (or angles) used as deck support system by welding them to the metal tab inserts on the girder top flange. The height of the bent plates was adjusted to achieve at least 3 in. thick haunch and provide the required deck profile after considering deck deflection.
4. Adjust the height of shear connectors to have an embedment in the deck of at least 5 in.
5. Attach compressive material (backer rod) to the top of the bent plates to prevent leakage.
6. Place precast concrete deck panels on the deck support system starting from the middle and moving outward.
7. Form the sides and bottom of transverse joints between adjacent deck panels using backer rod and wood forms.
8. Place the specified SCC mixture into transverse joints after cleaning and moistening them.
9. Place anchor plates, post-tensioning chucks, and bearing/bulkhead plates at the two end panels.

10. Post-tension the strands using mono-strand jack starting from the middle strands and moving outward in a symmetrical manner to minimize the eccentricity.
11. Pump the specified SCC from the pump sleeves welded to the bulkhead plate provided at girder ends until concrete overflow from the inspection vents. Pumping started by using a slurry to lubricate the haunch, then SCC was pumped from one end until the accumulated pressure caused uplifting of the specimen panels. Pumping stopped and proceeded from the other end until the haunch and pockets were completely filled and vents were plugged. Based on this experience, it's highly recommended to pour the SCC from the top of the deck through 4 in. diameter holes located at 12 ft spacing.

The cast-in-place SCC used for pouring the transverse joints and haunch has a specified minimum loading strength of 3.5 ksi, and a 28-day strength of 6 ksi. Figure 6.14 presents the compressive strength of the cast-in place SCC used in pouring the transverse joints and haunch. Mixture proportions are shown in Table 6.2

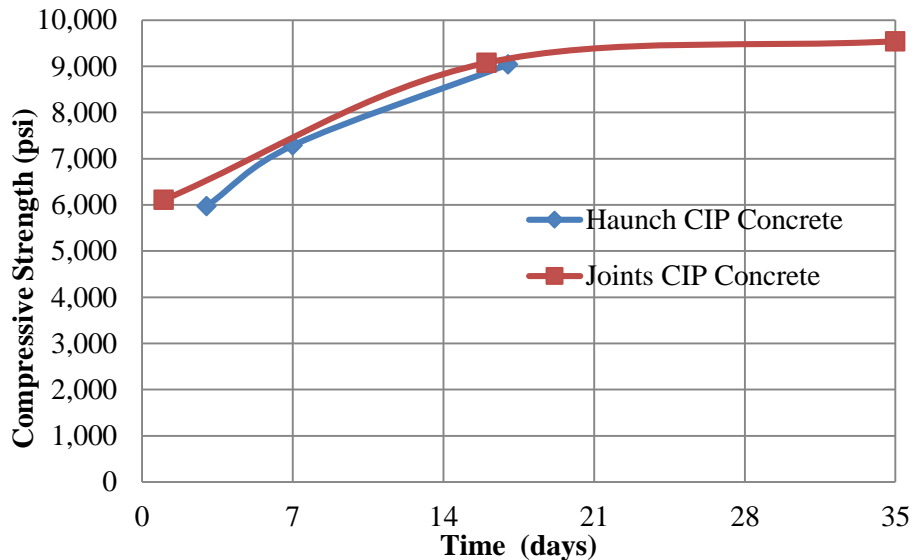

Figure 6.14: Concrete compressive strength for cast-in-place transverse joints and haunch

Table 6.2: Mixture proportions of SCC used for transverse joints and haunch

Component	Quantity	US Units
IPF Cement	866	lb/yd ³
Water	285	lb/yd ³
w/c	0.33	N/A
4110 Sand	1615	lb/yd ³
3/8 in. Limestone	1077	lb/yd ³
TOTAL AGG.	2692	lb/yd³
HRWR (Glenium 3030)	4	oz/cwt
Retarder (Delvo)	4	oz/cwt
VMA (Rheomac 362)	4	oz/cwt
AEA (MB-AE 90)	0.2	oz/cwt
WRA (RheoTEC Z-60)	4	oz/cwt

To measure the amount of pre-compression that the deck panels have after post-tensioning, detached mechanical (DEMEC) gauges were glued to the top surface of the deck at the location of the two intermediate transverse joints as shown in Figure 6.15. Six gauges were used at each joint to provide three readings. Readings were taken directly before post-tensioning and directly after post-tensioning to estimate the strain. Average strain was found to be 0.00024, which is slightly higher than the calculated strain of 0.00021 due to the applied post-tensioning force. This difference might be due to variations in the concrete strength and eccentricity of the applied force.

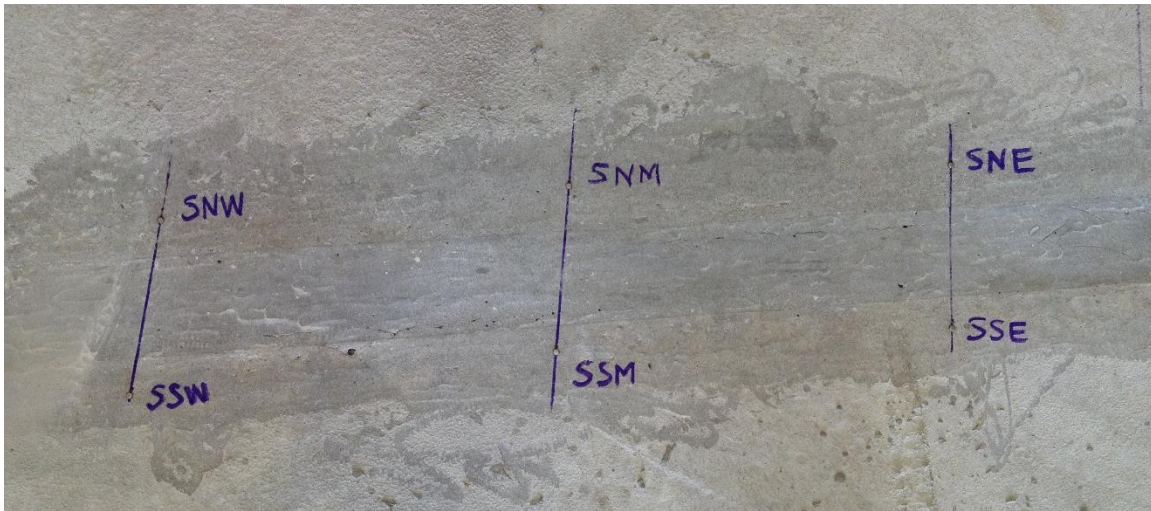

Figure 6.15: DEMEC gauges used to measure the deck strain due to post-tensioning

Figure 6.16 shows plan, elevation, and section views of the composite specimen with a typical and end panels. To evaluate the structural performance of the proposed shear connectors and their interface shear capacity, the full-scale specimen was tested in flexure using a concentrated load at the mid-span section as shown in Figure 6.17. This testing setup generates a uniform interface shear force on all the shear connectors. Based on the interface shear demand for the Kearney East Bypass project, which is 3.24 kip/in, it was estimated that a test load of 280 kips is needed. Also, based on strain compatibility analysis, a fully composite section would have a nominal moment capacity of 5550 kip.ft, which corresponds to a test load of 338 kip after excluding self-weight effects. Therefore, a 400 kip loading jack was used in testing. Also, several linear variable differential transformers (LVDTs) were used to monitor the horizontal and vertical displacements of the precast deck relative to the cast-in-place haunch as shown in Figure 6.18. It should be noted that the bent plates used as deck support system were removed only to provide a space to attach the LVDTs and visually evaluate the quality of the haunch concrete. Concrete and steel stain gauges were also used, as shown in Figure 6.18, to measure the concrete stresses in the deck, haunch, top and bottom girder flanges at 2 ft from the mid-span section and steel stresses at two shear connectors located approximately 7 ft from the end of the specimen. Also, string potentiometer was used to measure the specimen deflection at the mid-span section.

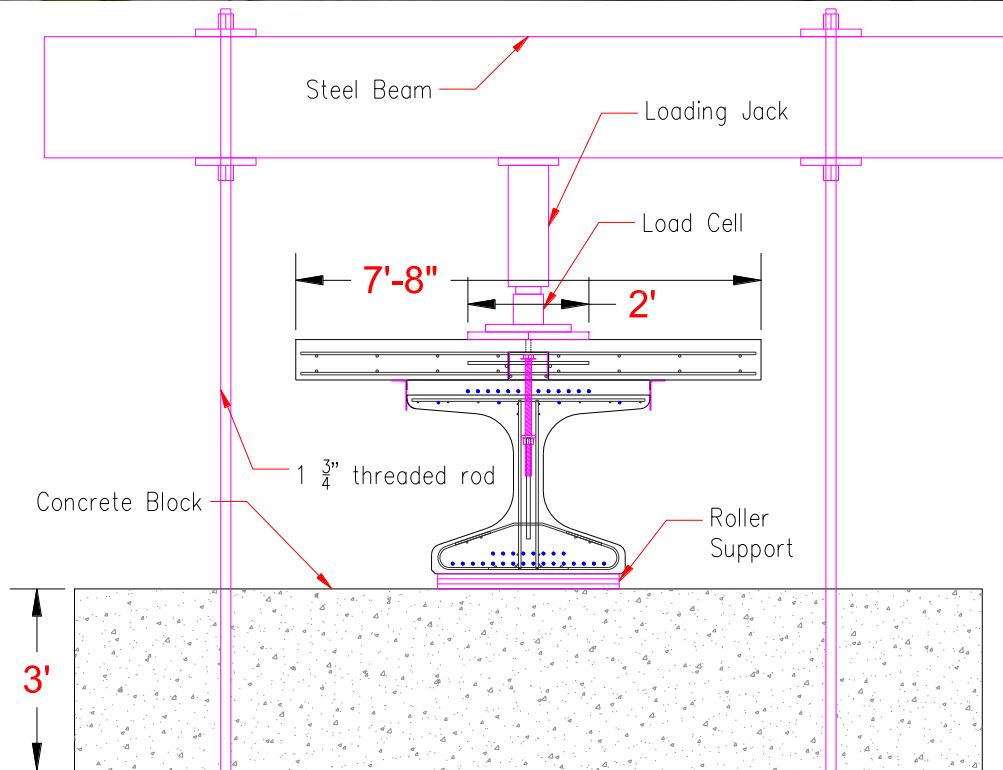

Figure 6.17: Test setup

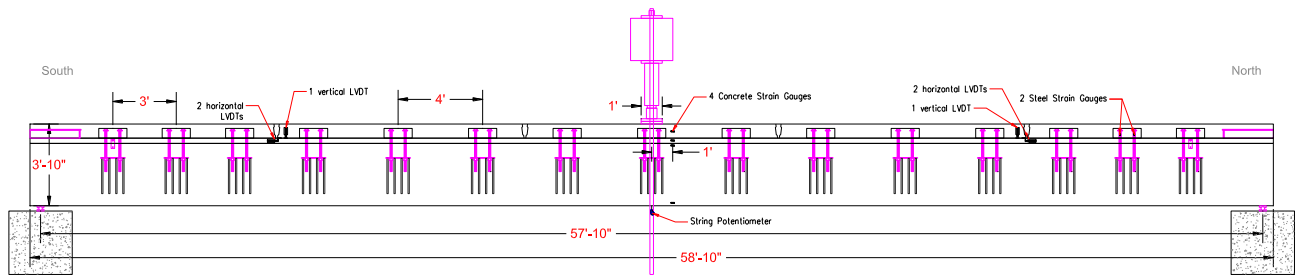

Figure 6.18: Specimen instrumentation

Testing was conducted by loading the specimen at 50 kip increments. After each loading increment, the specimen was visually inspected for cracking and cracks were marked to evaluate their propagation. This process was repeated until the load reached 200 kip. Then, the specimen

was loaded continuously to failure, which occurred at a load of 380 kip with a maximum deflection of 8.4 in. The load was released and the specimen maintained a permanent deflection of 3.6 in. Figure 6.19 plots the load-deflection relationship of the specimen, which represents its behavior while testing. This straight line relationship at the beginning indicates that the specimen remained un-cracked up to a load of 200 kips, which is higher than the calculated cracking load of 161 kip for a fully composite section. Table 6.3 lists the demand, theoretical capacity and measured capacity for both cracking and ultimate loads. This table indicates that the tested specimen outperformed the predicted capacities for a fully composite section. The failure mode of the specimen was the crushing of the deck concrete as shown in Figure 6.20. More photos of specimen cracking, crushing, and demolition are shown in Appendix D.

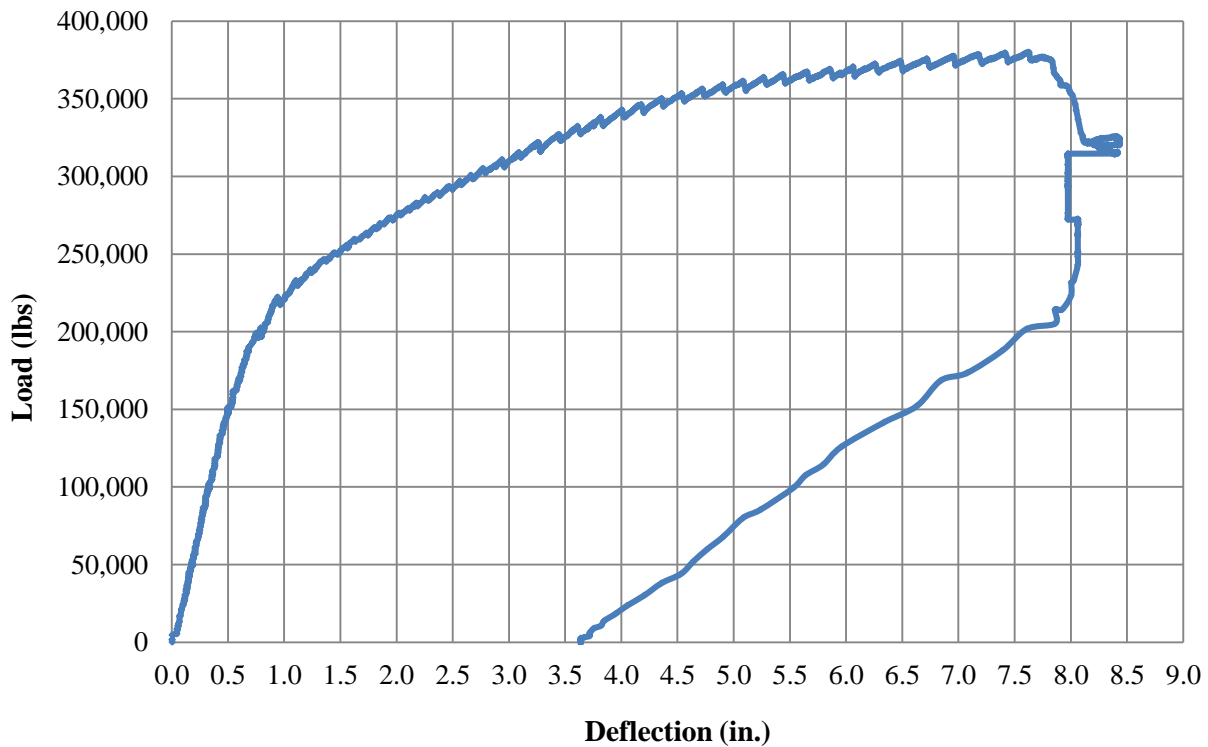

Figure 6.19: Load-deflection relationship of the specimen

Table 6.3 Comparing demand, design, and measured capacities

Load Type	Cracking Load (kip)	Ultimate Load (kip)
Demand	N/A	280
Theoretical Capacity	161	338
Measured Capacity	200	380
Ratio of Measured-to-Theoretical	1.24	1.12



Figure 6.20: Failure mode of the specimen

Figures 6.21 and 6.22 plot the measured horizontal and vertical displacements between the precast deck panels and cast-in-place haunch respectively. These plots indicate that there is no relative slippage between the components of the composite section even under ultimate loads as the measured displacements are significantly lower than 0.01 in., which is the limit for initial slippage as defined by several pushoff and pullout tests in the literature. Figure 6.23 plots the applied load versus the measured strain in two shear connectors. The maximum strain in the connectors is about 100μ in./in. which is very low strain. Although this value does not represent the actual strain in the connectors at the interface plane as the strain gauges are attached above the interface plane, it indicates that the contribution of concrete cohesion at the pocket locations and adhesion with the deck soffit are higher than predicted. Figure 6.24 presents the applied load versus the strain in concrete across the critical section. This figure confirmed that precast deck panel, haunch and girder top flange were in compression, while the girder bottom flange is in tension. The compressive stresses are the highest in the deck and increase as the load increases up to a load of 350 kips where compression failure of the deck began. The compressive stresses in the haunch and girder top flange decrease as the neutral axis moves up during loading. Also, the tensile stresses in the girder bottom flange are linear up to cracking, which occurred at 200 kips. Measured tensile stresses after cracking are not reliable.

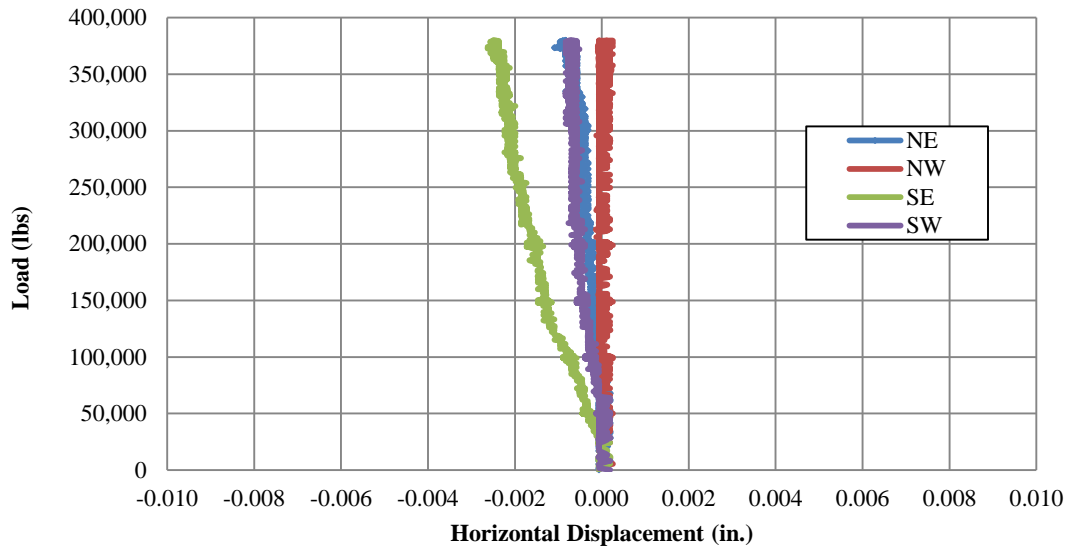

Figure 6.21: Horizontal displacement between precast deck panels and haunch

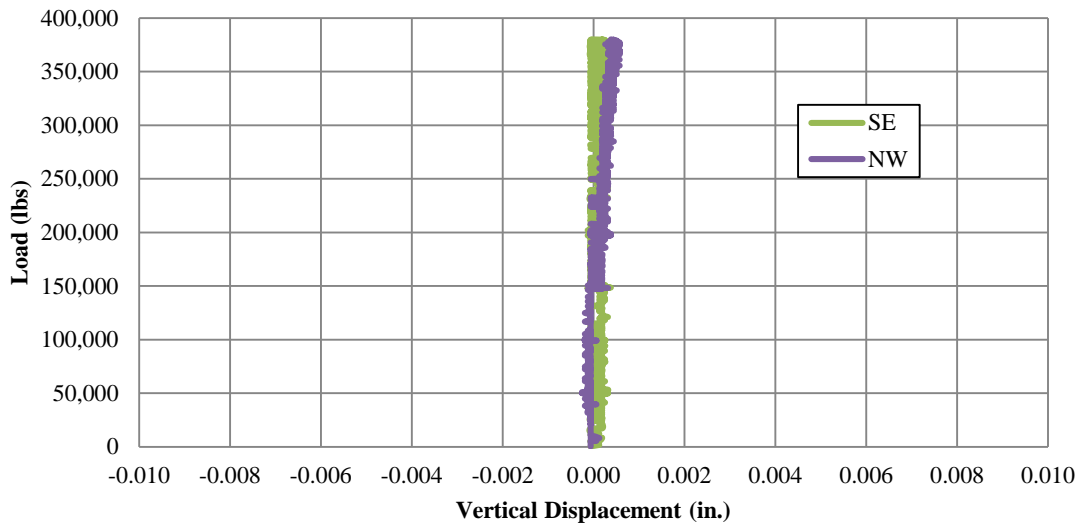

Figure 6.22: Vertical displacements between precast deck panels and haunch

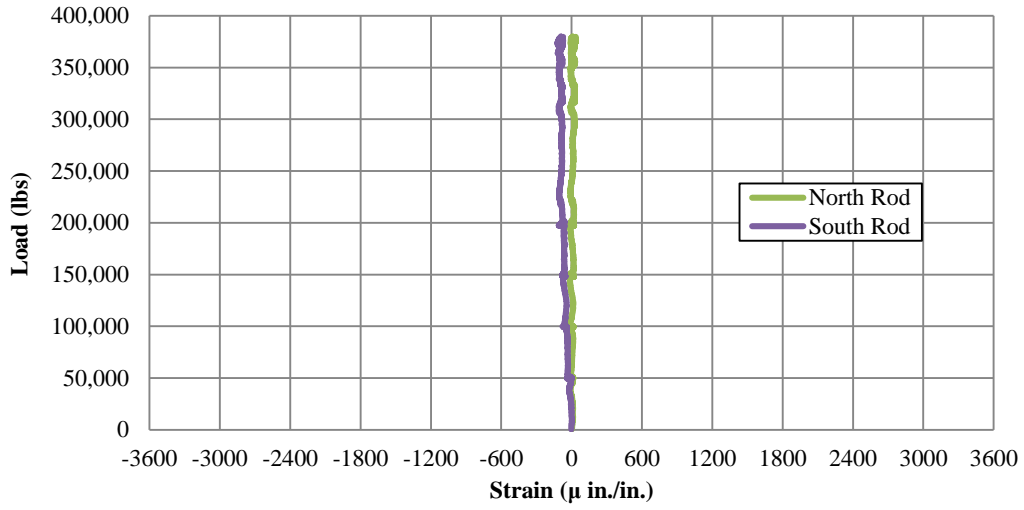

Figure 6.23: Measured strains in shear connectors

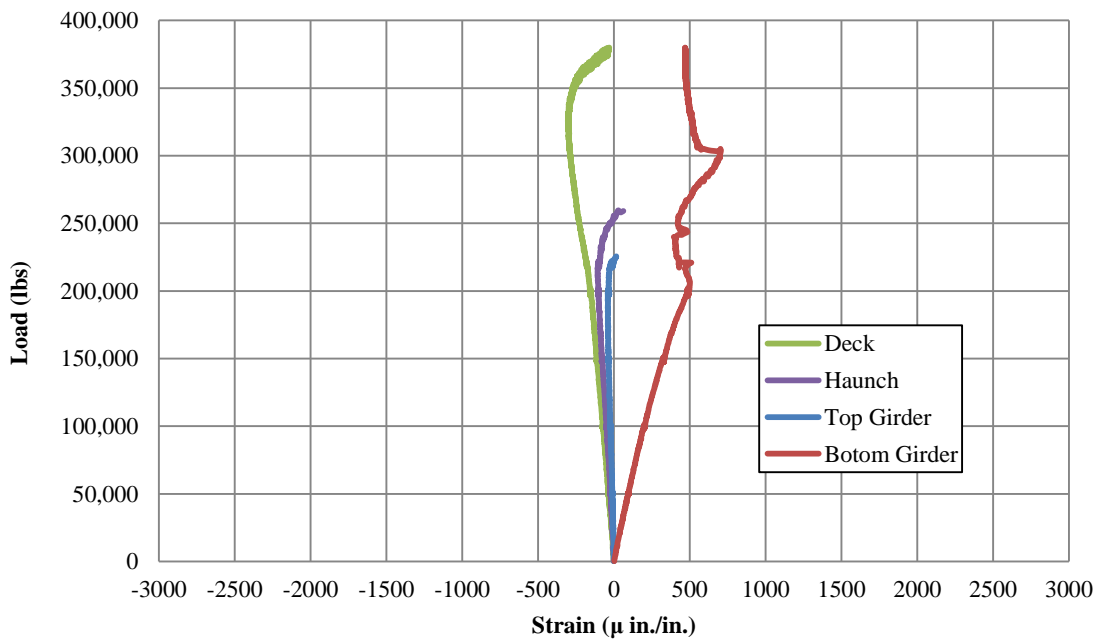

Figure 6.24: Measured strains in concrete

7 CONCLUSIONS

This report presented the analysis, design, detailing, and experimental investigation required to implement the second generation of the precast concrete deck system (NUDECK) to the Kearney East Bypass project in Kearney, NE. The project consists of a two-span continuous bridge that is 41 ft 8 in. wide and 332 ft long. Each span is 166 ft long and consists of five precast/prestressed concrete girders (NU1800) at 8 ft 6 in. spacing. The bridge deck consists of 28 full-width full-depth (8 in. thick) precast concrete panels that have the following innovative features:

- Panels are 12 ft long and weigh 50,000 lb each to minimize the number of panels to be fabricated, transported, and erected as well as the number of transverse joints to be cast in place.
- Panels have individual covered shear pockets at 4 ft spacing to simplify panel production eliminate the need for deck overlay, which accelerates bridge construction.
- Shear connectors are bundles of two 1.25 in. diameter threaded rods that are embedded in the girder at 48 in. spacing. The height of these connectors can be easily adjusted on site to accommodate camber variability.
- Panels can be lifted using inserts at shear pockets locations to minimize panel penetrations and simplify panel forming.
- Panels are prestressing in two directions (transverse pre-tensioning and longitudinal post-tensioning) to control cracking and increase the service life of the deck.
- Panel post-tensioning strands are located underneath the deck to eliminate threading strands through deck reinforcement or embedded ducts, which simplifies construction.

Several experimental investigations were conducted to evaluate the practicality, economic feasibility and structural performance of the innovative features presented above. The results of these investigations indicated that the 2nd generation of NUDECK is an efficient deck system for implementation in the Kearney East Bypass project.

8 REFERENCES

1. State-of-the-art Report on Full-depth Precast Concrete Bridge Deck Panels, Published by Precast/Prestressed Concrete Institute (PCI), SOA -01-1911, 2011.
2. Badie, S.S., and Tadros, M.K., "Full-Depth, Precast-Concrete Bridge Deck Panel Systems," National Cooperative Highway Research Program, NCHRP 12-65, Report 584, Transportation Research Board, Washington, D.C., 2008.
3. Badie, S.S., Baishya, M.C., and Tadros, M.K., "NUDECK- An Efficient and Economical Precast Bridge Deck System", Prestressed/Precast Concrete Institute (PCI) Journal, September-October, Vol. 43, No. 5, 1998, pp. 56-74.
4. Fallaha, S., Sun, C., Lafferty, M., and Tadros, M.K., "High Performance Precast Concrete NUDECK Panel System for Nebraska's Skyline Bridge," Prestressed/Precast Concrete Institute (PCI) Journal, September-October, Vol. 49, No. 5, 2004, pp. 40-50.
5. Hanna, K., Morcous, G., and Tadros, M.K., "Standardized Precast Prestressed Concrete Panels for Bridge Decks", 2008 Concrete Bridge Conference, PCA, St. Louis, MO, May 2008.
6. Hanna, K., Morcous, G., and Tadros, M.K., "Second Generation Precast Concrete Deck Panel (NUDECK) System", NDOR, Technical Report, Nov. 2010.
7. AASHTO LRFD Bridge Design Specifications, American Association of State Highway and Transportation Officials (AASHTO), Customary U.S. Units, Washington, D.C., 6th Edition, 2012.

9 APPENDICES

APPENDIX A: Analysis Results

Service III shear and bending envelope for an interior beam

Strength I shear and bending envelope for an interior beam

Strength I vertical and horizontal shear for an interior beam

Academic Use Only

| SHEET# 1

PROGRAM: LEAP® CONSPAN® V8i (SELECTseries 5)-v12.1.0
 Bentley Systems, Inc. - www.bentley.com
 PHONE : TOLL-FREE 1-800-778-4277

| JOB NO. 10-2(114)
 | BY SS/MJ DATE Apr/3/2012
 | CKD. G. Mo DATE Apr/23/2013
 |

PROJECT: Kearney East bypass Nul800

SHEAR AND MOMENT ENVELOPE : Span : 1, Beam : 3, SERVICE III
 Shears: kips, Moments: kft

		Bearing	Trans	H/2	0.10L	0.20L	0.30L	0.40L	Midspan
Location, ft		0.00	2.50	3.43	16.12	32.73	49.35	65.97	82.58
Self wt. : M		0.0	181.9	248.3	1074.4	1938.9	2556.3	2926.8	3050.3
(Max)	V	73.9	71.6	70.8	59.5	44.6	29.7	14.9	0.0
DL-Prec. : M		0.0	10.8	14.7	63.8	115.2	151.8	173.8	181.2
DC(Max)	V	4.4	4.3	4.2	3.5	2.6	1.8	0.9	0.0
DL-Prec. : M		0.0	0.0	0.0	0.0	0.0	0.0	0.0	0.0
DW(Max)	V	0.0	0.0	0.0	0.0	0.0	0.0	0.0	0.0
Deck + : M		0.0	202.9	277.0	1198.7	2163.1	2852.0	3265.3	3403.1
Haunch (Max)V		82.4	79.9	79.0	66.3	49.7	33.2	16.6	0.0
Diaphragm : M		0.0	0.0	0.0	0.0	0.0	0.0	0.0	0.0
(Max)	V	0.0	0.0	0.0	0.0	0.0	0.0	0.0	0.0
DL-Comp : M		0.0	32.0	43.6	183.1	314.8	388.7	404.7	362.8
DC(Max)	V	13.0	12.5	12.3	9.7	6.2	2.7	0.8	4.3
DL-Comp : M		0.0	23.8	32.4	136.3	234.3	289.3	301.2	270.0
DW(Max)	V	9.7	9.3	9.2	7.2	4.6	2.0	0.6	3.2
LL + I : M+		0.0	176.2	240.1	1016.5	1769.1	2236.8	2445.8	2415.1
	V	96.5	94.0	93.1	80.7	64.8	43.9	28.5	5.0
LL + I : M-		0.0	-20.9	-28.7	-134.8	-273.9	-412.9	-551.9	-690.9
	V	96.5	83.2	78.3	11.2	11.2	11.2	11.2	11.2
LL + I : Vmx		96.5	94.1	93.2	80.9	66.5	53.3	43.0	51.5
	M	0.0	173.4	236.0	975.3	1627.5	1964.9	1678.8	1647.3
Total : M+		0.0	627.5	856.1	3672.6	6535.3	8474.9	9517.6	9682.4
	V	279.9	271.7	268.6	226.9	172.6	113.3	62.2	12.4
Total : M-		0.0	0.0	0.0	0.0	0.0	0.0	0.0	0.0
	V	0.0	0.0	0.0	0.0	0.0	0.0	0.0	0.0
Total : Vmx		279.9	271.7	268.7	227.1	174.3	122.6	76.6	59.0
	M	0.0	624.7	852.0	3631.4	6393.8	8202.9	8750.6	8914.6

		0.60L	0.70L	0.80L	0.90L	H/2	Trans	Bearing
Location, ft		99.20	115.82	132.44	149.05	161.74	162.67	165.17
Self wt. : M		2926.8	2556.3	1938.9	1074.4	248.3	181.9	0.0
(Max)	V	14.9	29.7	44.6	59.5	70.8	71.6	73.9
DL-Prec. : M		173.8	151.8	115.2	63.8	14.7	10.8	-0.0
DC(Max)	V	0.9	1.8	2.6	3.5	4.2	4.3	4.4
DL-Prec. : M		0.0	0.0	0.0	0.0	0.0	0.0	0.0
DW(Max)	V	0.0	0.0	0.0	0.0	0.0	0.0	0.0
Deck + : M		3265.3	2852.0	2163.1	1198.7	277.0	202.9	0.0
Haunch (Max)V		16.6	33.2	49.7	66.3	79.0	79.9	82.4
Diaphragm : M		0.0	0.0	0.0	0.0	0.0	0.0	0.0
(Max)	V	0.0	0.0	0.0	0.0	0.0	0.0	0.0
DL-Comp : M		263.0	105.4	-110.1	-383.5	-631.2	-650.7	-704.0
DC(Max)	V	7.7	11.2	14.7	18.2	20.9	21.0	21.6
DL-Comp : M		195.8	78.4	-82.0	-285.5	-469.8	-484.3	-524.0
DW(Max)	V	5.8	8.4	10.9	13.5	15.5	15.7	16.1
LL + I : M+		2154.7	1674.3	1005.8	341.1	53.8	40.2	8.8
	V	19.7	33.8	47.2	37.8	9.5	7.4	1.8
LL + I : M-		-830.0	-969.0	-1297.1	-1599.3	-2216.0	-2274.5	-2440.3
	V	11.2	11.2	13.1	32.9	74.2	77.2	85.3
LL + I : Vmx		63.7	76.1	88.5	100.7	109.9	110.5	112.4
	M	1463.4	1053.8	428.8	-392.0	-1098.0	-1152.6	-1300.8
Total : M+		8979.4	7418.2	5030.8	2009.0	0.0	0.0	0.0
	V	65.5	118.0	169.8	198.8	0.0	0.0	0.0
Total : M-		0.0	0.0	0.0	0.0	-2776.9	-3013.9	-3668.2
	V	0.0	0.0	0.0	0.0	264.5	269.7	283.6
Total : Vmx		109.5	160.3	211.1	261.8	300.2	303.1	310.7
	M	8288.1	6797.7	4453.7	1275.8	-1658.9	-1892.0	-2528.8

Academic Use Only

| SHEET# 1
 | JOB NO. 10-2(114)
 | BY SS/MJ DATE Apr/3/2012
 | CKD. G. Mo DATE Apr/23/2013
 |

PROGRAM: LEAP® CONSPAN® V8i (SELECTseries 5)-v12.1.0
 Bentley Systems, Inc. - www.bentley.com
 PHONE : TOLL-FREE 1-800-778-4277

PROJECT: Kearney East bypass Nul800

SHEAR AND MOMENT ENVELOPE : Span : 1, Beam : 3, STRENGTH I
 Shears: kips, Moments: kft

		Bearing	Trans	H/2	0.10L	0.20L	0.30L	0.40L	Midspan
Location,	ft	0.00	2.50	3.43	16.12	32.73	49.35	65.97	82.58
Self wt. :	M	0.0	227.4	310.4	1343.0	2423.6	3195.4	3658.5	3812.9
(Max)	V	92.3	89.5	88.5	74.3	55.7	37.2	18.6	0.0
Self wt. :	M	0.0	163.7	223.5	967.0	1745.0	2300.7	2634.1	2745.3
(Min)	V	66.5	64.5	63.7	53.5	40.1	26.8	13.4	0.0
DL-Prec. :	M	0.0	13.5	18.4	79.8	143.9	189.8	217.3	226.5
DC (Max)	V	5.5	5.3	5.3	4.4	3.3	2.2	1.1	0.0
DL-Prec. :	M	0.0	9.7	13.3	57.4	103.6	136.6	156.4	163.1
DC (Min)	V	3.9	3.8	3.8	3.2	2.4	1.6	0.8	0.0
DL-Prec. :	M	0.0	0.0	0.0	0.0	0.0	0.0	0.0	0.0
DW (Max)	V	0.0	0.0	0.0	0.0	0.0	0.0	0.0	0.0
DL-Prec. :	M	0.0	0.0	0.0	0.0	0.0	0.0	0.0	0.0
DW (Min)	V	0.0	0.0	0.0	0.0	0.0	0.0	0.0	0.0
Deck + :	M	0.0	253.6	346.3	1498.3	2703.9	3565.0	4081.6	4253.9
Haunch (Max)V		103.0	99.9	98.7	82.9	62.2	41.5	20.7	0.0
Deck + :	M	0.0	182.6	249.3	1078.8	1946.8	2566.8	2938.8	3062.8
Haunch (Min)V		74.2	71.9	71.1	59.7	44.8	29.8	14.9	0.0
Diaphragm :	M	0.0	0.0	0.0	0.0	0.0	0.0	0.0	0.0
(Max)	V	0.0	0.0	0.0	0.0	0.0	0.0	0.0	0.0
Diaphragm :	M	0.0	0.0	0.0	0.0	0.0	0.0	0.0	0.0
(Min)	V	0.0	0.0	0.0	0.0	0.0	0.0	0.0	0.0
DL-Comp :	M	0.0	40.0	54.4	228.8	393.5	485.8	505.8	453.5
DC (Max)	V	16.3	15.7	15.4	12.1	7.7	3.4	1.0	5.3
DL-Comp :	M	0.0	28.8	39.2	164.8	283.3	349.8	364.2	326.5
DC (Min)	V	11.7	11.3	11.1	8.7	5.6	2.4	0.7	3.8
DL-Comp :	M	0.0	35.7	48.6	204.4	351.5	433.9	451.8	405.0
DW (Max)	V	14.6	14.0	13.8	10.8	6.9	3.0	0.9	4.8
DL-Comp :	M	0.0	15.5	21.1	88.6	152.3	188.0	195.8	175.5
DW (Min)	V	6.3	6.1	6.0	4.7	3.0	1.3	0.4	2.1
LL + I :	M+	0.0	440.4	600.3	2541.1	4422.8	5591.9	6114.6	6037.6
	V	241.2	235.0	232.8	201.7	162.1	109.7	71.4	12.5
LL + I :	M-	0.0	-52.3	-71.8	-337.1	-684.7	-1032.2	-1379.8	-1727.3
	V	241.2	208.1	195.8	28.0	28.0	28.0	28.0	28.0
LL + I :	Vmx	241.2	235.1	232.9	202.3	166.2	133.1	107.4	128.8
	M	0.0	433.5	589.9	2438.1	4068.8	4912.1	4197.0	4118.3
Total :	M+	0.0	1010.5	1378.4	5895.4	10439.2	13461.9	15029.6	15189.3
	V	472.9	459.4	454.4	386.2	297.9	196.9	113.6	22.6
Total :	M-	0.0	0.0	0.0	0.0	0.0	0.0	0.0	0.0
	V	0.0	0.0	0.0	0.0	0.0	0.0	0.0	0.0
Total :	Vmx	472.9	459.5	454.6	386.9	302.1	220.3	149.6	138.9
	M	0.0	1003.6	1368.1	5792.4	10085.2	12782.1	13112.0	13269.9

		0.60L	0.70L	0.80L	0.90L	H/2	Trans	Bearing
Location,	ft	99.20	115.82	132.44	149.05	161.74	162.67	165.17
Self wt. :	M	3658.5	3195.4	2423.6	1343.0	310.4	227.4	0.0
(Max)	V	18.6	37.2	55.7	74.3	88.5	89.5	92.3
Self wt. :	M	2634.1	2300.7	1745.0	967.0	223.5	163.7	0.0
(Min)	V	13.4	26.8	40.1	53.5	63.7	64.5	66.5
DL-Prec. :	M	217.3	189.8	143.9	79.8	18.4	13.5	-0.0
DC (Max)	V	1.1	2.2	3.3	4.4	5.3	5.3	5.5
DL-Prec. :	M	156.4	136.6	103.6	57.4	13.3	9.7	-0.0
DC (Min)	V	0.8	1.6	2.4	3.2	3.8	3.8	3.9
DL-Prec. :	M	0.0	0.0	0.0	0.0	0.0	0.0	0.0
DW (Max)	V	0.0	0.0	0.0	0.0	0.0	0.0	0.0
DL-Prec. :	M	0.0	0.0	0.0	0.0	0.0	0.0	0.0
DW (Min)	V	0.0	0.0	0.0	0.0	0.0	0.0	0.0
Deck + :	M	4081.6	3565.0	2703.9	1498.3	346.3	253.6	0.0

Academic Use Only

| SHEET# 2

PROGRAM: LEAP® CONSPAN® V8i (SELECTseries 5)-v12.1.0
Bentley Systems, Inc. - www.bentley.com
PHONE : TOLL-FREE 1-800-778-4277

| JOB NO. 10-2(114)
| BY SS/MJ DATE Apr/3/2012
| CKD. G. Mo DATE Apr/23/2013
|

PROJECT: Kearney East bypass Nu1800

Haunch (Max)V	20.7	41.5	62.2	82.9	98.7	99.9	103.0
Deck + : M	2938.8	2566.8	1946.8	1078.8	249.3	182.6	0.0
Haunch (Min)V	14.9	29.8	44.8	59.7	71.1	71.9	74.2
Diaphragm : M	0.0	0.0	0.0	0.0	0.0	0.0	0.0
(Max) V	0.0	0.0	0.0	0.0	0.0	0.0	0.0
Diaphragm : M	0.0	0.0	0.0	0.0	0.0	0.0	0.0
(Min) V	0.0	0.0	0.0	0.0	0.0	0.0	0.0
DL-Comp : M	328.8	131.7	-137.7	-479.4	-789.0	-813.4	-880.0
DC(Max) V	9.7	14.0	18.4	22.7	26.1	26.3	27.0
DL-Comp : M	236.7	94.8	-99.1	-345.2	-568.1	-585.6	-633.6
DC(Min) V	7.0	10.1	13.2	16.4	18.8	18.9	19.4
DL-Comp : M	293.6	117.6	-123.0	-428.2	-704.7	-726.5	-785.9
DW(Max) V	8.6	12.5	16.4	20.3	23.3	23.5	24.1
DL-Comp : M	127.2	51.0	-53.3	-185.5	-305.4	-314.8	-340.6
DW(Min) V	3.7	5.4	7.1	8.8	10.1	10.2	10.4
LL + I : M+	5386.7	4185.7	2514.4	852.8	134.5	100.5	22.0
V	49.2	84.4	117.9	94.4	23.8	18.6	4.6
LL + I : M-	-2074.9	-2422.4	-3242.7	-3998.3	-5539.9	-5686.2	-6100.7
V	28.0	28.0	32.7	82.3	185.4	193.0	213.3
LL + I : Vmux	159.3	190.2	221.2	251.8	274.7	276.4	280.9
M	3658.6	2634.5	1071.9	-980.1	-2744.9	-2881.4	-3252.0
Total : M+	13966.5	11385.2	7633.4	3243.2	0.0	0.0	0.0
V	107.9	191.8	274.0	299.1	0.0	0.0	0.0
Total : M-	0.0	0.0	0.0	-2802.7	-6547.5	-6870.0	-7766.6
V	0.0	0.0	0.0	223.9	352.9	362.3	387.8
Total : Vmux	218.0	297.6	377.3	456.5	516.5	520.9	532.8
M	12238.4	9834.1	6082.6	1033.4	-3563.5	-3926.8	-4918.0

Academic Use Only

| SHEET# 1
| JOB NO. 10-2(114)
| BY SS/MJ DATE Apr/3/2012
| CKD. G. Mo DATE Apr/23/2013
|

PROGRAM: LEAP® CONSPAN® V8i (SELECTseries 5)-v12.1.0
Bentley Systems, Inc. - www.bentley.com
PHONE : TOLL-FREE 1-800-778-4277

PROJECT: Kearney East bypass Nul800

VERTICAL SHEAR (Art. 5.8) - Span : 1, Beam : 3, STRENGTH I
Using General Beta Theta Equation procedure - Art.5.8.3.4.2

Location (ft)	Vu (kips)	bv (in)	de (in)	Aps (in ²)	Vp (kips)	eps_x (in)	Theta Beta	Vs-reqd (kips)	Av/s (in ² /ft)	Av-prvd (in ² /ft)	Al_reqd (in ²)
Moor (kft)	a (in)	dv (in)	fpo (ksi)	vu/fc	Vc-com (kips)			Max.spc. (in)	min.Av/s (in ² /ft)	pVn/Vu	Aps* (in ²)

Bearing :	0.50										
472.9	5.9	78.1	1.469	5.5	6.00e-3	50.0	478.8	1.462	0.880	1.80	
0.0	0.0	78.1	31.5	0.109	41.1	0.87	24.00	0.121	0.637*	0.701	
Transfer:	3.00										
459.5	5.9	78.4	9.982	33.2	-0.20e-3	28.3	210.8	0.290	0.880	0.00	
1003.6	0.0	78.4	189.0	0.100	266.6	5.65	24.00	0.121	1.841	5.221	
Critical:	6.84										
439.1	5.9	78.4	9.982	33.2	-0.21e-3	28.3	194.0	0.274	0.880	0.00	
2381.4	4.6	76.1	189.0	0.098	260.6	5.69	24.00	0.121	1.878	7.642	
0.1L :	16.62										
386.9	5.9	78.4	9.982	33.2	-0.12e-3	28.6	158.9	0.231	0.440	0.00	
5792.4	6.7	75.0	189.0	0.086	237.8	5.26	24.00	0.121	1.335	9.746	
0.2L :	33.23										
302.1	5.9	72.1	12.586	33.2	-0.07e-3	28.8	93.3	0.149	0.220	0.00	
10085.2	6.7	68.7	189.0	0.072	209.2	5.05	24.00	0.121	1.132	12.586	
0.3L :	49.85										
220.3	5.9	74.2	13.020	33.2	-0.02e-3	28.9	3.3	0.121	0.110	0.00	
12782.1	6.7	70.9	189.0	0.049	208.3	4.88	24.00	0.121	1.275	13.020	
0.4L :	66.47										
149.6	5.9	77.5	13.020	0.0	-0.04e-3	28.9	0.0	0.121	0.110	0.00	
13112.0	6.7	74.1	189.0	0.037	220.2	4.93	24.00	0.121	1.769	13.020	
0.5L :	83.08										
138.9	5.9	77.5	13.020	0.0	-0.03e-3	28.9	0.0	0.121	0.110	0.00	
13269.9	6.7	74.1	189.0	0.034	219.8	4.92	24.00	0.121	1.903	13.020	
0.6L :	99.70										
218.0	5.9	77.5	13.020	0.0	-0.05e-3	28.8	19.6	0.121	0.110	0.00	
12238.4	6.7	74.1	189.0	0.053	222.6	4.99	24.00	0.121	1.225	13.020	
0.7L :	116.32										
297.6	5.9	74.2	13.020	33.2	-0.10e-3	28.6	75.6	0.121	0.110	0.00	
9834.1	6.7	70.9	189.0	0.069	221.9	5.19	24.00	0.121	0.987*	13.020	
0.8L :	132.94										
377.3	5.9	72.1	12.586	33.2	-0.19e-3	28.4	155.2	0.244	0.220	0.00	
6082.6	6.7	68.7	189.0	0.092	230.8	5.57	24.00	0.121	0.964*	12.586	
0.9L :	149.55										
456.5	5.9	78.4	9.982	33.2	-0.20e-3	28.3	218.7	0.314	0.440	0.00	
1033.4	6.7	75.0	189.0	0.103	255.4	5.65	24.00	0.121	1.173	9.746	
Critical:	159.12										
501.8	5.9	78.6	3.038	33.2	0.63e-3	31.2	370.0	0.570	0.880	2.09	
-2432.8	0.0	78.6	189.0	0.109	154.3	3.26	24.00	0.121	1.361	2.353	
Transfer:	163.17										
520.9	5.9	78.6	3.038	33.2	0.81e-3	31.8	404.1	0.638	0.880	4.47	
-3926.8	0.0	78.6	189.0	0.113	141.5	2.99	24.00	0.121	1.265	2.670	
Bearing :	165.67										
532.8	5.9	78.6	1.469	5.5	1.97e-3	35.9	494.7	0.911	0.880	15.21	
-4918.0	0.0	78.6	31.5	0.122	91.8	1.94	24.00	0.121	0.972*	0.614	

Academic Use Only

| SHEET# 2

PROGRAM: LEAP® CONSPAN® V8i (SELECTseries 5)-v12.1.0
Bentley Systems, Inc. - www.bentley.com
PHONE : TOLL-FREE 1-800-778-4277

| JOB NO. 10-2 (114)
| BY SS/MJ DATE Apr/3/2012
| CKD. G. Mo DATE Apr/23/2013
|

PROJECT: Kearney East bypass Nul800

ANCHORAGE ZONE REINFORCEMENT (Art. 5.10.10)

Span : 1, Beam : 3

Fpi, kips = 2021.35
fs, ksi = 20.00
h/4, in = 17.72
Abrst_rqrd, in2 = 4.04

HORIZONTAL SHEAR (Art. 5.8.4) - Span : 1, Beam : 3

(Beam and Slab effects are EXCLUDED from Vu).

Manual input Interface width considered to be engaged in shear transfer, bvi = 32.00(in).

Location (ft)

	Vu (kips)	Vnh-req (kips/in)	de (in)	a (in)	dv (in)	s_max (in)	Avh-min (in2/ft)	Avh-sm (in2/ft)	Avh-rg (in2/ft)	Avh-prvd (in2/ft)

Bearing :	0.00									
272.0	3.87	78.07	0.00	78.07	24.00	0.274	0.420	0.000	0.000*	
Transfer:	2.50									
264.8	3.75	78.36	0.00	78.36	24.00	0.274	0.387	0.000	0.000*	
Critical:	6.34									
253.6	3.70	78.36	4.57	76.07	24.00	0.274	0.373	0.000	0.000*	
0.1L :	16.12									
225.2	3.34	78.36	6.74	74.99	24.00	0.274	0.268	0.000	0.000*	
0.2L :	32.73									
180.9	2.93	72.06	6.70	68.71	24.00	0.274	0.150	0.000	0.000*	
0.3L :	49.35									
139.5	2.19	74.24	6.71	70.89	24.00	0.274	0.000	0.000	0.000	
0.4L :	65.97									
109.2	1.64	77.46	6.71	74.10	24.00	0.274	0.000	0.000	0.000	
0.5L :	82.58									
138.9	2.08	77.46	6.71	74.10	24.00	0.274	0.000	0.000	0.000	
0.6L :	99.20									
177.6	2.66	77.46	6.71	74.10	24.00	0.274	0.075	0.000	0.000*	
0.7L :	115.82									
216.8	3.40	74.24	6.71	70.89	24.00	0.274	0.285	0.000	0.000*	
0.8L :	132.44									
256.1	4.14	72.06	6.70	68.71	24.00	0.274	0.497	0.000	0.000*	
0.9L :	149.05									
294.9	4.37	78.36	6.74	74.99	24.00	0.274	0.563	0.000	0.000*	
Critical:	158.62									
316.9	4.48	78.63	0.00	78.63	24.00	0.274	0.594	0.000	0.000*	
Transfer:	162.67									
326.2	4.61	78.63	0.00	78.63	24.00	0.274	0.631	0.000	0.000*	
Bearing :	165.17									
331.9	4.69	78.63	0.00	78.63	24.00	0.274	0.654	0.000	0.000*	

PRELIMINARY PLAN
 NOT FINAL - SUBJECT TO CHANGE

POST-TENSIONING NOTES:

POST-TENSIONING STRAND shall be uncased, seven-wire, low-relaxation steel strand of 0.6" nominal diameter, and shall conform to the requirements of ASTM A416, Grade 270. Strands shall be tensioned to 4394 Kips before release, unless specified otherwise. All methods employed and procedures to be followed in tensioning the strands shall be subject to the Engineer's approval. The method chosen shall be executed in a manner to assure that the ends of all strands are uniformly post-tensioned. The post-tensioned strand shall be released and anchored in a manner that will minimize eccentricity.

- All girders shall be placed on the entire bridge prior to placement of Deck Panels.
- The support system shall be installed on the top Girder Flange and adjusted so as to support the Deck Panels at the correct elevations by taking shims into account.
- The NU prefabricated deck panels shall be placed as shown in the panel layout. Care should be taken that the panels are in tight contact with the base of the girder and that proper alignment is achieved.
- Beginning at either end of the deck, tension two of the innermost strands at the center girder to the specified force.
- Repeat step four, tensioning from the centroid of the strand pattern outward in both horizontal directions so as to maintain symmetry during the post-tensioning process. Repeat until all of the strands at the end of the deck have been tensioned.
- Re-tension all strands at the opposite end of the deck to the required force.

PRECAST DECK PANEL NOTES:

FABRICATOR shall be responsible for exercising extreme care in lifting, handling, storing and transportation of the prestressed deck panels to prevent cracking or damage. Information, refer to the relevant NDOR research report. If different lifting devices and/or lifting locations are proposed, a demonstration panel shall be made and approved prior to panel fabrication. Lifting points and/or devices shall be shown on the shop plans.

PRETENSIONING STRAND For NU-Deck Panels shall be uncased, seven-wire, low-relaxation steel strand of 0.6" nominal diameter, and shall conform to the requirements of ASTM A416, Grade 270. Strands shall be tensioned to 4394 Kips before release, unless specified otherwise. All methods employed and procedures to be followed in tensioning the strands shall be subject to the Engineer's approval. The method chosen shall be executed in a manner to assure that the ends of all strands are uniformly post-tensioned. The prestressed strand shall be released in a manner that will minimize eccentricity.

CONCRETE in the panels shall be Class "4750" Type "1" with concrete strengths at stress to the concrete not less than 4000 psi. The concrete shall be placed and cured to the concrete nor the end anchorage released until the concrete has attained the specified strength.

STRANDS at panel ends shall be removed to a depth of one inch inside the panel edge. The resulting pocket shall be grouted with a high strength, non-shrink grout.

REINFORCING STEEL shall conform to the requirements of ASTM designation A615/A616M, Grade 60.

DIMENSIONAL TOLERANCES shall be in accordance with the Prestressed Concrete Institute Manual For Quality Control, MIL-116-99, 4th Edition.

FOR INFORMATION ONLY

Items Included in the pay item:
 POST-TENSIONING

GROUT	61.2	CY
HANCHES	66.6	CY
6 # Post-Tensioning Strands	2020	LF
Post-Tensioning Anchor Plates	88	LBS
Post-Tensioning Anchor Chucks	120	EA

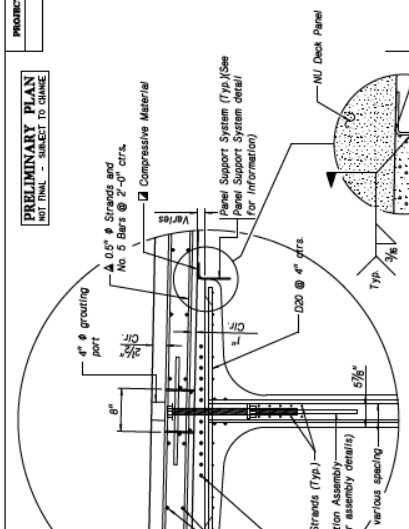

SECTION D-D
 Not to Scale
 See Plan View of 8' NU Deck Panel on sheet 31 of 48 for location of Section D-D

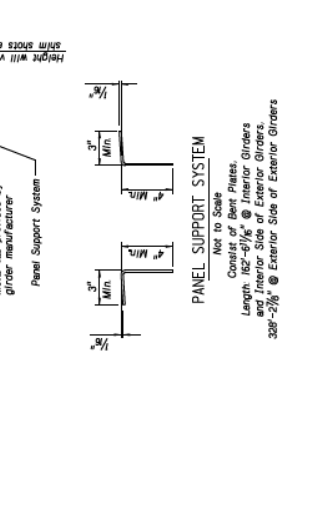

PARTIAL ELEVATION OF INTERIOR PANEL TO GIRDER CONNECTION
 Not to Scale
 See sheet 32 of 48 for additional details

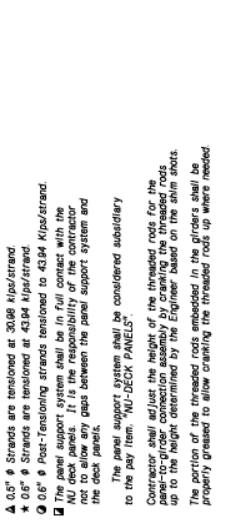

PARTIAL PLAN OF INTERIOR PANEL TO GIRDER CONNECTION

DECK PANEL SUPPORT SYSTEM
 Not to Scale
 Consists of Bent Piles
 Length 182'-9 1/2" @ Interior Girders
 Length 182'-9 1/2" @ Exterior Girders
 328'-2 1/2" @ Exterior Side of Exterior Girders

DECK PANEL SUPPORT SYSTEM shall provide continuous support for the panel. The ultimate load that the NU girder top flange can carry is 4 kips/ft, acting on the tip of the flange. The contractor is responsible to ensure that the deck panel support system is of adequate capacity to support the deck panels, and any construction loads that may be imposed.

See sheet 31A of 48 for post-tensioning notes
 0.5" # Strands are tensioned at 30.88 kips/strand
 0.6" # Strands are tensioned at 43.84 kips/strand
 0.6" # Post-Tensioning strands tensioned to 43.84 kips/strand
 The panel-to-girder connection shall be in full contact with the NU deck panels. It is the responsibility of the contractor not to allow any gaps between the panel support system and the deck panels.
 The panel support system shall be considered subsidiary to the pay item, "NU-DECK PANELS".
 Contractor shall adjust the height of the threaded rods for the panel-to-girder connection assembly by cranking the threaded rods up to the height determined by the Engineer based on the shim shos. The portion of the threaded rods embedded in the girders shall be properly grouted to allow cranking the threaded rods up where needed.

PRELIMINARY PLAN
 NOT FINAL - SUBJECT TO CHANGE

STATE OF NEBRASKA - DEPARTMENT OF ROADS - BRIDGE DIVISION
PROJECT NUMBER 10-2(116)
CONTRACT NUMBER C.N. 42103B
PROJECT LOCATION S.O.D. 05443 L&R
STATE OF NEBRASKA - DEPARTMENT OF ROADS - BRIDGE DIVISION
DATE APRIL 2013
DESIGNED BY MR. [Name]
CHECKED BY [Name]
SCALE 1/4" = 1'-0"
LOCATION KEARNEY EAST BYPASS
SKETCH LHB (11th ST. TO 56th ST.)
ROWAY 38'-0"
DESIGN L&R HL-93
DESIGN L&R HL-93
DATE APRIL 2013
STATE OF NEBRASKA - DEPARTMENT OF ROADS - BRIDGE DIVISION

STATE OF NEBRASKA - DEPARTMENT OF ROADS - BRIDGE DIVISION
PROJECT NUMBER 10-2(116)
CONTRACT NUMBER C.N. 42103B
PROJECT LOCATION S.O.D. 05443 L&R
STATE OF NEBRASKA - DEPARTMENT OF ROADS - BRIDGE DIVISION
DATE APRIL 2013
DESIGNED BY MR. [Name]
CHECKED BY [Name]
SCALE 1/4" = 1'-0"
LOCATION KEARNEY EAST BYPASS
SKETCH LHB (11th ST. TO 56th ST.)
ROWAY 38'-0"
DESIGN L&R HL-93
DESIGN L&R HL-93
DATE APRIL 2013
STATE OF NEBRASKA - DEPARTMENT OF ROADS - BRIDGE DIVISION

STATE OF NEBRASKA - DEPARTMENT OF ROADS - BRIDGE DIVISION
PROJECT NUMBER 10-2(116)
CONTRACT NUMBER C.N. 42103B
PROJECT LOCATION S.O.D. 05443 L&R
STATE OF NEBRASKA - DEPARTMENT OF ROADS - BRIDGE DIVISION
DATE APRIL 2013
DESIGNED BY MR. [Name]
CHECKED BY [Name]
SCALE 1/4" = 1'-0"
LOCATION KEARNEY EAST BYPASS
SKETCH LHB (11th ST. TO 56th ST.)
ROWAY 38'-0"
DESIGN L&R HL-93
DESIGN L&R HL-93
DATE APRIL 2013
STATE OF NEBRASKA - DEPARTMENT OF ROADS - BRIDGE DIVISION

STATE OF NEBRASKA - DEPARTMENT OF ROADS - BRIDGE DIVISION
PROJECT NUMBER 10-2(116)
CONTRACT NUMBER C.N. 42103B
PROJECT LOCATION S.O.D. 05443 L&R
STATE OF NEBRASKA - DEPARTMENT OF ROADS - BRIDGE DIVISION
DATE APRIL 2013
DESIGNED BY MR. [Name]
CHECKED BY [Name]
SCALE 1/4" = 1'-0"
LOCATION KEARNEY EAST BYPASS
SKETCH LHB (11th ST. TO 56th ST.)
ROWAY 38'-0"
DESIGN L&R HL-93
DESIGN L&R HL-93
DATE APRIL 2013
STATE OF NEBRASKA - DEPARTMENT OF ROADS - BRIDGE DIVISION

STATE OF NEBRASKA - DEPARTMENT OF ROADS - BRIDGE DIVISION
PROJECT NUMBER 10-2(116)
CONTRACT NUMBER C.N. 42103B
PROJECT LOCATION S.O.D. 05443 L&R
STATE OF NEBRASKA - DEPARTMENT OF ROADS - BRIDGE DIVISION
DATE APRIL 2013
DESIGNED BY MR. [Name]
CHECKED BY [Name]
SCALE 1/4" = 1'-0"
LOCATION KEARNEY EAST BYPASS
SKETCH LHB (11th ST. TO 56th ST.)
ROWAY 38'-0"
DESIGN L&R HL-93
DESIGN L&R HL-93
DATE APRIL 2013
STATE OF NEBRASKA - DEPARTMENT OF ROADS - BRIDGE DIVISION

STATE OF NEBRASKA - DEPARTMENT OF ROADS - BRIDGE DIVISION
PROJECT NUMBER 10-2(116)
CONTRACT NUMBER C.N. 42103B
PROJECT LOCATION S.O.D. 05443 L&R
STATE OF NEBRASKA - DEPARTMENT OF ROADS - BRIDGE DIVISION
DATE APRIL 2013
DESIGNED BY MR. [Name]
CHECKED BY [Name]
SCALE 1/4" = 1'-0"
LOCATION KEARNEY EAST BYPASS
SKETCH LHB (11th ST. TO 56th ST.)
ROWAY 38'-0"
DESIGN L&R HL-93
DESIGN L&R HL-93
DATE APRIL 2013
STATE OF NEBRASKA - DEPARTMENT OF ROADS - BRIDGE DIVISION

STATE OF NEBRASKA - DEPARTMENT OF ROADS - BRIDGE DIVISION
PROJECT NUMBER 10-2(116)
CONTRACT NUMBER C.N. 42103B
PROJECT LOCATION S.O.D. 05443 L&R
STATE OF NEBRASKA - DEPARTMENT OF ROADS - BRIDGE DIVISION
DATE APRIL 2013
DESIGNED BY MR. [Name]
CHECKED BY [Name]
SCALE 1/4" = 1'-0"
LOCATION KEARNEY EAST BYPASS
SKETCH LHB (11th ST. TO 56th ST.)
ROWAY 38'-0"
DESIGN L&R HL-93
DESIGN L&R HL-93
DATE APRIL 2013
STATE OF NEBRASKA - DEPARTMENT OF ROADS - BRIDGE DIVISION

STATE OF NEBRASKA - DEPARTMENT OF ROADS - BRIDGE DIVISION
PROJECT NUMBER 10-2(116)
CONTRACT NUMBER C.N. 42103B
PROJECT LOCATION S.O.D. 05443 L&R
STATE OF NEBRASKA - DEPARTMENT OF ROADS - BRIDGE DIVISION
DATE APRIL 2013
DESIGNED BY MR. [Name]
CHECKED BY [Name]
SCALE 1/4" = 1'-0"
LOCATION KEARNEY EAST BYPASS
SKETCH LHB (11th ST. TO 56th ST.)
ROWAY 38'-0"
DESIGN L&R HL-93
DESIGN L&R HL-93
DATE APRIL 2013
STATE OF NEBRASKA - DEPARTMENT OF ROADS - BRIDGE DIVISION

APPENDIX C: Specimen Fabrication





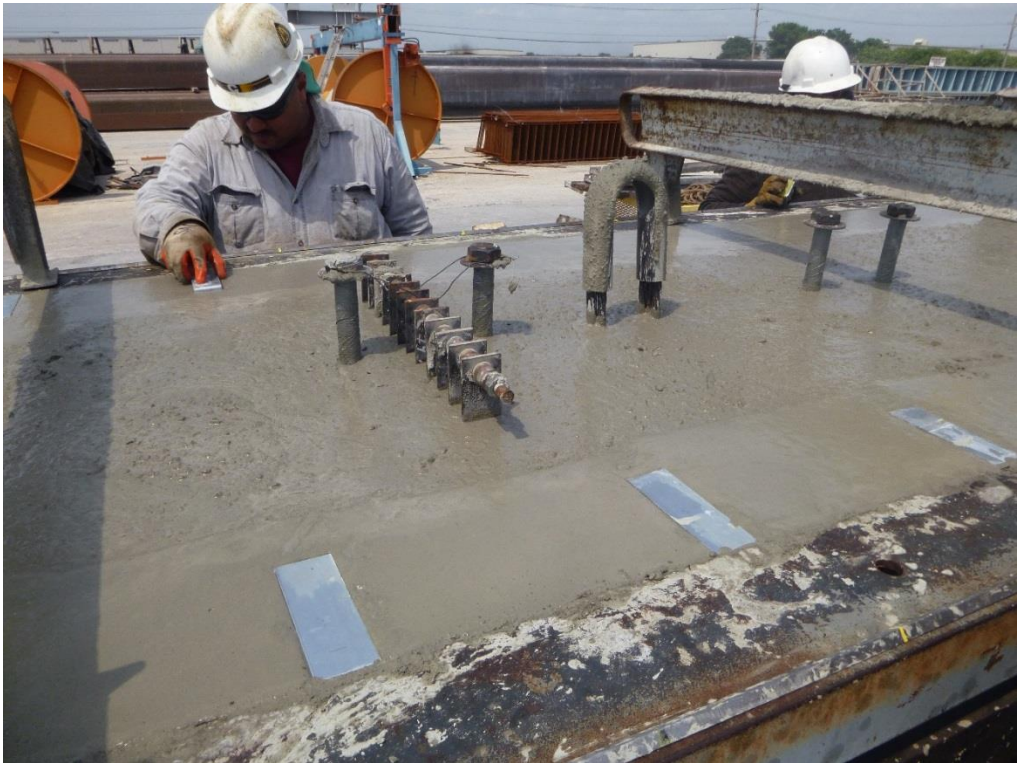







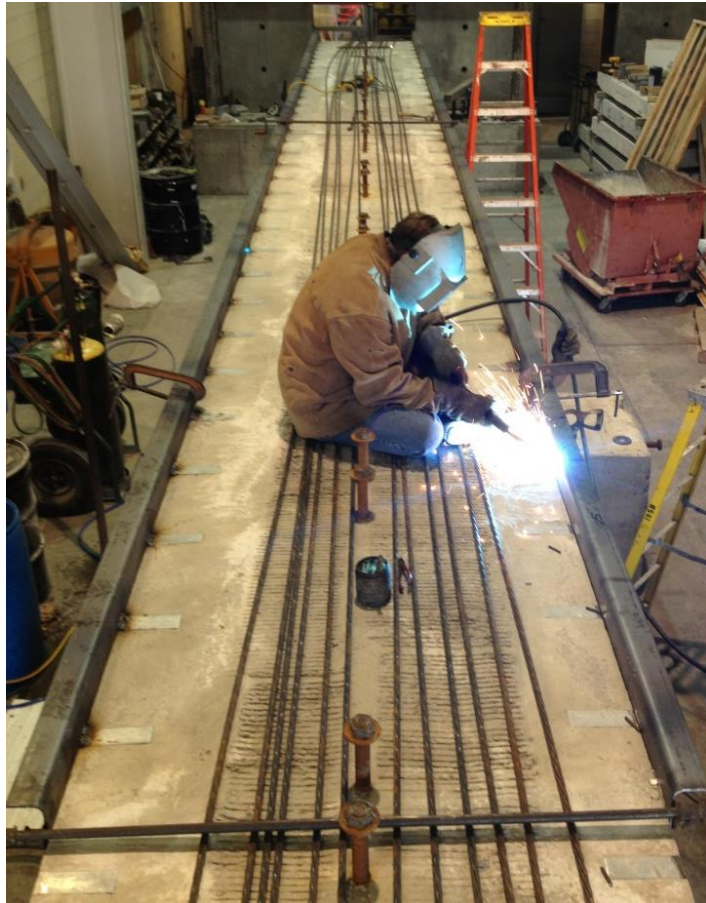









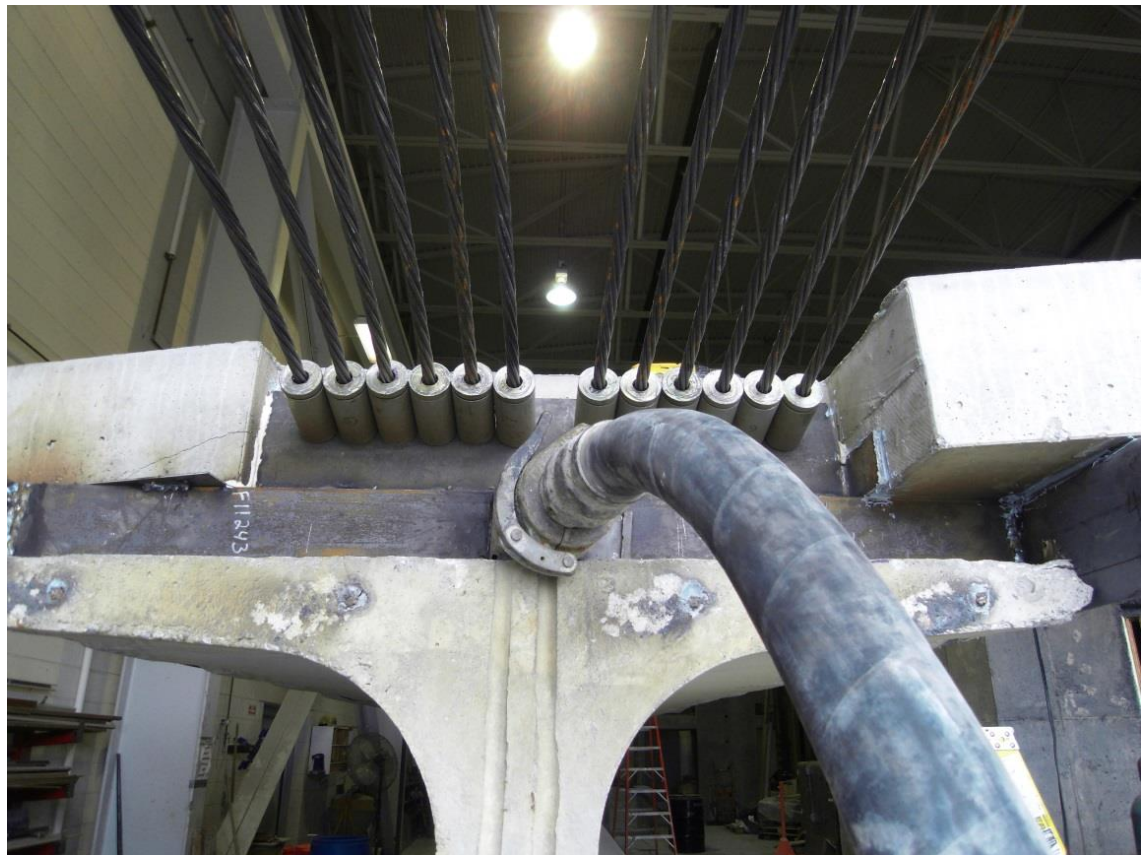



APPENDIX D: Specimen Testing

