

2016

NRES/METR/BSEN 479/879: Hydroclimatology—A Peer Review of Teaching Project Benchmark Portfolio

Francisco Munoz-Arriola
University of Nebraska-Lincoln, fmunoz@unl.edu

Follow this and additional works at: <http://digitalcommons.unl.edu/prtunl>

 Part of the [Atmospheric Sciences Commons](#), [Engineering Commons](#), [Higher Education Commons](#), and the [Higher Education and Teaching Commons](#)

Munoz-Arriola, Francisco, "NRES/METR/BSEN 479/879: Hydroclimatology—A Peer Review of Teaching Project Benchmark Portfolio" (2016). *UNL Faculty Course Portfolios*. 12.
<http://digitalcommons.unl.edu/prtunl/12>

This Portfolio is brought to you for free and open access by the Peer Review of Teaching Project at DigitalCommons@University of Nebraska - Lincoln. It has been accepted for inclusion in UNL Faculty Course Portfolios by an authorized administrator of DigitalCommons@University of Nebraska - Lincoln.

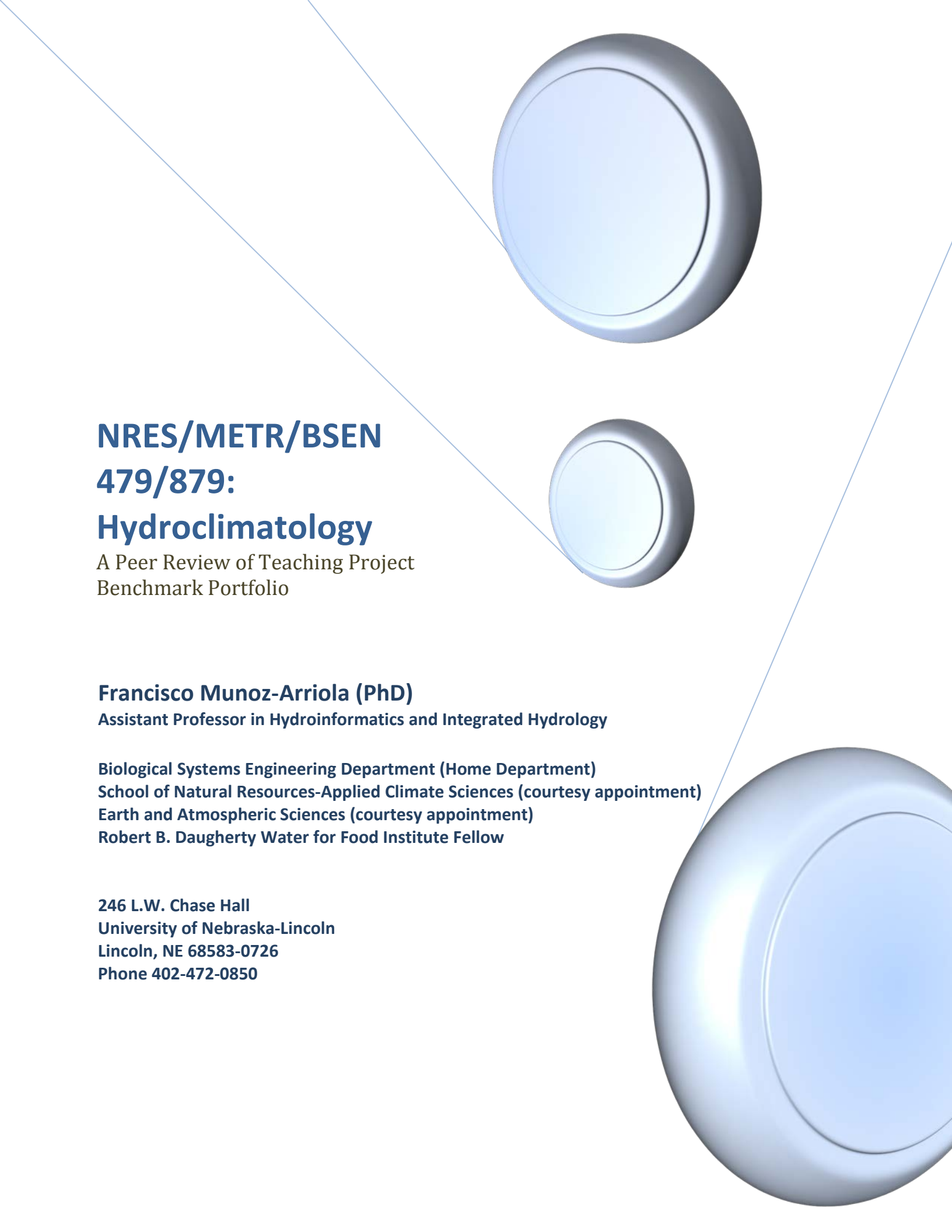
The page features three large, light blue, 3D-rendered circles of varying sizes. Two thin blue lines intersect at the top left, extending diagonally across the page. The largest circle is in the top right, a medium one in the middle right, and the smallest one in the bottom right.

NRES/METR/BSEN 479/879: Hydroclimatology

A Peer Review of Teaching Project
Benchmark Portfolio

Francisco Munoz-Arriola (PhD)

Assistant Professor in Hydroinformatics and Integrated Hydrology

Biological Systems Engineering Department (Home Department)
School of Natural Resources-Applied Climate Sciences (courtesy appointment)
Earth and Atmospheric Sciences (courtesy appointment)
Robert B. Daugherty Water for Food Institute Fellow

246 L.W. Chase Hall
University of Nebraska-Lincoln
Lincoln, NE 68583-0726
Phone 402-472-0850

ABSTRACT

Rising temperatures and extreme hydrometeorological and climate events are evidences of a changing climate. An increasing population together with their demands for food, energy and water make changes in climate evidence the need to train a new generation of multidisciplinary professionals with a clear understanding of the effects of a changing climate in their activities. Historically, climate sciences were used for scientific and weather operational contexts and engineers applied stationary assumptions for multi-term planning. My goal is to identify elements built from classroom experiences about (a) the suitability of a hydroclimatology course for engineers and scientists; (b) the multidisciplinary skills; (c) computational skills. I developed a completely new course in content and format. The content aims to show students local-to-global hydroclimatological experiences on science, engineering and entrepreneurship as “intellectual incentives”. The format aims to explore different forms of communicating knowledge from theoretical (lectures) to practical (labs), to explanatory (discussions). I assessed two classic aspects: (a) understanding; (b) application on three groups of students from environmental, engineering (3), and atmospheric (3) backgrounds. While analytical understanding was based on the students responses in what I call a 3-dimentional assessment (multiple choice, specific question responses, and analytical responses) the midterm, the practical understanding was based on students performance to use computational and modeling skills.

Keywords: hydroclimatology, integrative, data science, modeling, climate

TABLE OF CONTENTS

DESCRIPTION	3
QUESTIONS.....	4
OBJECTIVES.....	5
Hypotheses:	5
Particular hypotheses:	6
Built Hypotheses	6
METHOD	7
IMPLEMENTATION:	7
ELEMENTS OF HYPOTHESES TESTING.....	8
About Lectures	8
About Discussions	9
About Labs	9
About the Midterm.....	10
About the Final Project.....	11
About Questionnaires	11
Subject Objectives	11
About Student's Evaluation	12
EVALUATION	13
INTERESTS	13
FORMAT.....	14
CONTENT	14
ANALYSES OF STUDENT LEARNING.....	15
FORMAT.....	16
CONTENT	18
PLANNED CHANGES.....	19
FORMAT.....	19
CONTENT	19
CONCLUSIVE REMARKS	20
SUMMARY AND OVERALL ASSESSMENT.....	21
APPENDICES.....	22

DESCRIPTION

Climate is a forcing of the Earth Living Support System. As such, has been part of our history and will define our future. The water we drink, the crops we farm, the energy we distribute, and the ecosystems we enjoy are defined by variations in weather over short periods of time (sub-daily to weekly) or historical fluctuations of climate (sub-monthly to multi-decadal). Those fluctuations of weather and climate influence a complex set of interdependencies of physical, biological/biogeochemical and socioeconomic processes within the Earth Living Support System where water is a key element. Precipitation is arguably the main driver of the hydrologic cycle; its intensification is affected by the dynamics of the ocean and the atmosphere and contributes to modulate the exchange of moisture and energy with the land surface at multiple spatial and temporal scales. To better understand the Climate and Water Systems' interdependency a multidisciplinary conceptual framework founded on scientific, engineering and innovation perspectives has to be developed and integrative tools based on data science and environmental modeling built. Research-wise we have made some progress toward model integration and systems' decoupling using numerical and analytical techniques, however, in the classroom we still need to integrate multidimensional perspectives to solve challenges such as drought forecast, water resilience, the nexus water-food-energy, and improve communication of sound information to decision and policy makers. From the premise that Hydroclimatology is an integrative field of study between the broad atmospheric and hydrologic sciences and water resources engineering my goal is to develop a course that involves a new generation of scientists and engineers with theoretical and computational skills to solve multidisciplinary problems in a non-stationary world.

The course was initially developed for majors in Natural Resources (NRES) and Meteorology (METR) programs, we pursue to cross-list hydroclimatology with the Biological Systems Engineering (BSEN) program. While NRES and METR undergraduate and graduate programs have addressed independently weather- and climate-related courses their primary focus is on the physical principles that drive the dynamics of the atmosphere and the hydrologic processes that govern the water and energy balances in the land surface, respectively. On the other hand, water resources engineering courses in Biological Systems and Civil Engineering focus on the physics of natural and built environment on the land surface assuming a principle of stationary. Considering positive trends in global temperature and the incidence of hydrometeorological extreme events the principle of stationary is no longer applicable. Thus, a change of paradigm is required for planning, decision- and policy-making. Some of the scientific and technologic aspects related with non-stationary hydroclimatic systems include the development of analytics and synthesis techniques that allow scientists and engineers manage growing amounts of data, synthesizing them to generate and communicate sound information to a diverse group of users "thirsty" of climate information. Also, more integrative models are required to improve weather and climate forecast and help natural and manage ecosystems, societies, and economies so decisions made are more informed.

An example of problems tackled in class is represented in Figure 1. Changes in farmer's revenues over time show an integrated representation of climate, water resources, and socioeconomic factors. While farmer's revenues integrate the economics behind the role played by technologic development (seen by the positive trend in response to genetics improvement over time), extreme hydrometeorological and climate events (EHCEs) produced a drop in farmers' annual revenues. This simple graph represents multiple components at various spatiotemporal scales and dimensions. Decoupling those components would lead to better understand the mechanisms of systems' integration and EHCEs' predictability. The scientific advancements and technologic developments are behind the mechanisms that would lead farmers to improve planning and decision-making. The solution of these challenges has to be developed by teams formed by scientist and engineers, as well as by social scientist and economist. All these professionals require multidisciplinary and integrative approaches in the classroom as well as in the exercise of their profession.

Thus, NRES/METR/BSEN 479/879 HYDROCLIMATOLOGY (from here called NRES 479/879; [Appendix 1](#)) is a course designed for undergraduate/graduate students. NRES 479/879's home is core course on the Natural Resources undergraduate/graduate program and is part of the Meteorology graduate and undergraduate program (METR 479/879) in the School of Natural Resources and Earth and Atmospheric Sciences Department.

QUESTIONS

How to teach climate principles to water resources and irrigation engineers? How atmospheric scientists improve their understanding of physical principles of hydrology? How all develop skills on data science and integrative modeling using hydroclimate system principles?

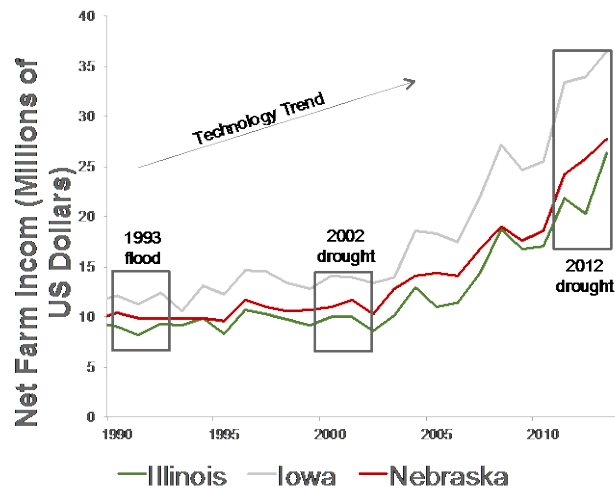

Figure 1. Annual variability in Net Farm income in three states in the Corn Belt in response to changes in technology (i.e. genetics) seen as the positive trend; and the effect of extreme Hydrometeorological end Climate Events.

OBJECTIVES

- 1) Develop a “planning” perspective in NRES and METR students with emphasis on water resources
- 2) Build a non-stationary criteria for project design and planning, involving hydroclimatological criteria and tools in engineers
- 3) Implement methodologies to study and practice data science and modeling hydroclimate systems
- 4) Develop a hydroclimate System’s project to support their current research interests
- 5) Develop a multidisciplinary perspective
- 6) Justify and cross-list of NRES/METR 479/879 with BSEN 479/879

Hypotheses:

My overall hypothesis is that students in undergraduate and graduate programs in Natural Resources (Applied Climate Sciences), Earth and Atmospheric Sciences (Meteorology), and Biological Systems Engineering will develop solid research (problem-solution) projects using hydroclimatic information through an integrative teaching-learning approach. An integrative teaching-learning approach is aimed to fulfill hydroclimate systems’ needs from data exploration and management to modeling implementation in undergraduate and graduate students in NRES, EAS, and BSEN. While the learning component is designed to address key technical and scientific deficiencies on the land surface-atmospheric interactions from data management to processes understanding, the teaching component will articulate the fundamentals, classic and state of current research, and basic tools, all used to better understand the physical principles and drivers of land surface hydrologic processes and spatiotemporal changes in precipitation. This process will be tested, contrasting a concept paper requested during the third week of class and the final project at the end of the course.

As preamble to the particular hypotheses [Appendix 2](#) (Table I a and b) show the climate-base courses for the Meteorology (METR) and Natural Resources (NRES) undergraduate and graduate programs. The information was collected from their respective webpages and do not state if all those courses were taught during the previous spring and fall semesters. Points to highlight are the following: (a) Undergraduate and graduate programs in NRES and BSEN have a reduced computational training that would allow them to access and manage large databases (see [Appendix 2](#), Table I.b); (b) EAS students before their senior year had already exposed to analytical and numerical methods in courses such as Dynamic Meteorology I and II and Synoptic Meteorology; (c) NRES students’ course work is focused on introduction courses such as Weather & Climate; (d) BSEN students have no climate-related courses through their whole undergraduate and graduate programs; (e) BSEN have basic programming courses and a strong analytical and numerical non-climate courses.

Particular hypotheses:

The hypotheses below are based on the value that the present course can bring to METR, NRES, and BSEN undergraduate and graduate programs.

1. For NRES and BSEN students, will address technical deficiencies in data access, management and analyses.
2. For EAS students, will address scientific deficiencies in land surface hydrologic principles.
3. NRES, EAS, and BSEN students, will address all technical and scientific deficiencies in land surface hydrologic modeling implementation and analyses.
4. Evaluation of the present course's format justifies the change in the course description statement, the syllabus, and the cross listing with BSEN.

Built Hypotheses

Based on the review of the course work in METR and NRES (Applied Climate Sciences) Table I evidences an important overlapping of courses. The remaining courses in both programs are complementary and can strength a more robust and integrated undergraduate and graduate program in "Meteorology and Applied Climate Sciences". The wealth of water resources and Irrigation engineering courses in BSEN can contribute to create a water resources minor in such program.

METHOD

These elements were collected from three aspects collected from Assignments and Final Project: (a) all projects were based on current research interests or research theses; (b) Lectures, Discussions, and Labs were inclusive and the same for all; (c) Assignments were designed to provide the same aid and tools and enhance the final project.

The course includes lectures, lab experiences, and refereed-literature reviews/discussions with five home assignments and a final project (oral and written formats).

The present course is a combination of three elements:

- (1) Foundational understanding of the principles that define the physical, biological/biogeochemical, and socioeconomic aspects of the Water and Climate Systems
- (2) Ability to identify spatial and temporal changes on the physical, biological/biogeochemical, and socioeconomic aspects of the Water and Climate Systems
- (3) Ability to interpret information to identify interdependencies between the water and climate systems while solving practical problems

IMPLEMENTATION:

(1) Lectures will be presented as PowerPoint/Key/Prezi presentations followed by group discussions. These presentations along with all other notes and assignments will be posted on Blackboard. Eleven lectures will cover a framework of principles and processes that will allow the student to better understand the water and climate systems. Classes will be characterized by (a) an explicit goal and scientific question or technologic gap at the beginning; (b) a development based on a hypothesis-driven approach that will lead to (c) answer the question formulated at the beginning and formulate the next-class'

question. (2) Labs will be run in SNR or BSE computational laboratories, which have access to the Holland Computing Center where accounts will be set up for each student. Nine lab-sessions will be conducted on a hypotheses-test approach, consistent in exploration, development, and implementation of techniques aimed to address the scientific question or technologic gap defined in the associated lecture.

(3) Five

Discussion sessions will be based on reviews of refereed papers at the end of each main topic (on process, modeling, and interdisciplinary applications).

Note: It is possible that a discussion session would be beneficial before the Lab sessions to better understand the implementation of the techniques used to address the associated questions or technological gaps discussed during the lectures.

ELEMENTS OF HYPOTHESES TESTING

About Lectures

How “deep” should be the information provided in this course based on the diversity of the student’s majors?

Ten lectures were aimed to provide foundational principles of hydroclimate systems (8 lectures) and fulfill practical needs and applications (2 invited talks). As can be seen in the syllabus, lectures cover practical aspects of hydroclimate data access and management, followed by hydrologic and groundwater principles, modeling of land surface-atmosphere interactions, and hydroclimate system debates and applications. [Appendix 3](#) shows an example of the Lectures (power point presentation)

Data Access and Management

This component of the course is built upon the principle of “good quality data will produce information”. Hydroclimate data access is a matter of knowing (a) where the data are? (2) How to retrieve the data? (3) What to do with data? These questions are addressed by (1) identifying the sources of hydroclimate data; (2) providing the tools to download and standardize data; (3) and teaching the spatial and temporal context the data can be analyzed. These classes aim to homogenize or provide with tools and understanding of data science to all students, expecting METR students have a experience on the subject but not necessarily knowledge on potential use of hydroclimate data.

Hydrologic and groundwater principles

These lectures were designed to provide a basic understanding of the principles that drive the spatial distribution and temporal variability of land surface hydrological components of the water cycle (i.e. runoff, evapotranspiration, baseflow, groundwater flow, soil moisture, snow water equivalent, streamflow, and precipitation) from a water resources perspective. Rainfall and snowfall were taken as drivers of the hydrologic cycle and variables that integrate a wealth of multi-scale atmospheric, oceanic and land surface phenomena (without identifying causality in their spatiotemporal variability). The target audience in terms of increasing literacy and understanding were METR students and partially NRES students. It is assumed that BSEN students have had hydrology and water resources courses previously.

Modeling of land surface-atmosphere interactions

During these classes we aim to identify causality of the spatial distribution and temporal variability of precipitation. We use the spatiotemporal variability to identify how land surface-atmospheric interactions are affected by multi-scale climate phenomena. Hence, the student with no climate background could have access to another forms of analyze and incorporate data into their own field’s research. Students from NRES and BSEN programs were the main targets on these

lessons so they could have a succinct review of phenomena affecting climate from local to global and from sub-daily to multi-decadal scales.

Hydroclimate system debates and applications

Once processes and their scales have been identified, the focus is on identifying how hydroclimate system analyses have been used and how they have transformed the analyses and interpretation of multi-scale climate phenomena and their effect on land surface hydrology. These classes were aimed to evidence how extreme hydrometeorological and climate events delineate climate change's effects, predictability, and the associated systems' risks, resilience, or transformation.

About Discussions

What should be the role of the instructor in the discussions? Should all the discussions have the same format? Is it relevant if the discussion occur after the lecture and the lab?

Five discussions (Data science, data management, land surface-atmosphere interactions, stationary vs. non stationary engineering, model vs observations) were designed to reaffirm what was covered in class. Discussions started from a major contribution of the instructor to gradually lead by the students. While the first discussion's format on Data Science described how data availability has grown in the past few years and their use for scientific discovery are defined by technologic processes and innovation, also evidences the challenges of cyber security and data provenance. The second discussion encourages students to talk about the spatiotemporal contexts on hydroclimate data, emphasizing the estimation and representation of uncertainty. The third discussion is aligned with classes on land surface hydrologic processes and land surface-atmospheric interactions. Here, students discussed the interaction water-vegetation-climate from local to global scales and how these interactions are observed and simulated by different tools (in situ and remote sensing observations as well as modeling resources). The last two discussions were designed in a debate and panel formats. While the debate on stationary vs non stationary systems involved seminal contributions on climate change vs the land use change as well as stationary vs. non-stationary arguments, the panel discussion on observation vs modeling was aimed to evidence the need of both resources in hydroclimate system's research. [Appendix 4](#) shows an example of a Discussion presentation (in Power Point).

About Labs

Should the class have less labs (i.e. as many as Assignments)?

Ten Labs ([Appendix 5](#)) were designed to complement lectures and discussions. Labs are hands-on and problem-solving activities aimed to provide knowledge and

training to use basic tools, access hydroclimate data publically available, and simulate and evaluate hydroclimate systems. Ultimately, these activities and tools are integrated to develop a solid final report. Labs were sequential and evaluated through 5 home works (Data Science, Final Project Outline, Data Access, Land Surface Modeling, and Methodology). The sequence of activities is designed to help the student develop her project.

The First three labs (*Assignments 1 and 3*) allow the student to access and visualize spatial and temporal representations of precipitation, minimum and maximum temperatures and wind speed using basic UNIX/LINUX-based programming language and MATLAB codes previously developed for this class. For *Assignment 2* students meet for 30 minutes with the lecturer and start shaping their final projects. A Concept Paper of their Final Project is requested and instructions on how to write such document and develop a successful proposal were provided ([Appendix 6](#)). The main objective of this Assignment is to identify the hydroclimatologic perspective of the students early in the semester based on broad hydroclimate concepts but clearer understanding of their own graduate/undergraduate research interests. Eventually, the tools, perspectives and knowledge accumulated through the course would add more hydroclimatological elements to their research as could be evidenced in their Final Project.

Labs 4-6 provide to students (a) understanding of physical principles used in modeling resources such as the land surface hydrology Variable Infiltration Capacity (VIC) model; (b) data needs and model implementation; (c) model simulation; and (d) post processing of modeled land surface variables and state variables in climate spatiotemporal contexts. It is considered critical to use a simple, yet broadly tested and fully functional model, to teach the scientific background, the technical requirements, and the scientific and technologic constrains of modeling. Thus, *Assignment 4* was designed to evaluate the students understanding in modeling, which allow them to use other modeling resources to prove it.

Finally, labs 7-9 provided evaluation tools. These labs and the associated tools were designed to allow students to post-process their data for hydroclimate analyses. They can use those tools provided or use something else as far as they deliver the requested in the Final Project. Considering that students at this point should have data to force their models, an experimental design, simulations and even tools to post-process the data, they should be able to write the methodology for their Final Project (*Assignment 5*) and help alleviate the load of work they may have toward the end of the semester.

About the Midterm

Is a midterm enough? Would be better to have a mid-term project review instead?

The first part of the test was used to evaluate students' understanding of the physical principles of distributing precipitation on the land surface across spatial and temporal scales. However, the second part of the test combined learning and

evaluation. The former allowed the students to identify the level of complexity of the systems we have used in the course and how they can be implemented in modeling activities (See [Appendix 7](#)).

About the Final Project

Should the Final Project be an independent topic from the students' research theses? Is the Final Project the best subject to assess class success?

Graduate students who are enrolled in NRES/METR/BSEN 879 will be required to complete a final project in oral and written formats, while undergraduate students will do an oral presentation of their final projects. Projects will consist of class presentation/report of her/his own research project findings especially placed in the context of topics previously discussed in class. Presentations must adhere to the requirements of professional seminar presentations. The objectives of this assignment are 1) to exemplify how topics previously discussed in class are associated with a broad range of research projects and subjects outside the classroom; 2) to foster public speaking in the undergraduate/graduate student – a skill required in any professional field; and 3) to promote the student's ability to convey her/his technologic and scientific expertise in a way that is understandable to educated but not expert audiences. If the student lacks a relevant research project, a review seminar on a topic to be agreed upon with the class instructors will be presented. [Appendix 8](#) shows an example of a Final Project.

About Questionnaires

Is it the final questionnaire enough to evaluate the course?

Three sets of questions were given to the class. (1) In Assignment 1; (2) In the Midterm; and; (3) At the end of the semester. These questionnaires contain different questions relevant to particular subjects in the class. The questionnaire was aimed to identify how labs can be improved. The Midterm questionnaire was part of the text and was aimed to provide a perspective on the application of hydroclimatology in science and engineering. The Final Questionnaire was 27-question document aimed to get feedback on the main components of the class (lectures, discussions and labs). [Appendix 9](#) shows the questionnaires collected.

Subject Objectives

- (1) Understand the processes that drive the water and climate systems, as well as their spatiotemporal scales;
- (2) Identify and characterize the availability and reliability of *in situ* and remote sensing, modeling, and merged data used to track physical, biological/biogeochemical, and socioeconomic components of the global water

system in a changing climate;

(3) Explore and implement the use land surface hydrologic and climate models with emphasis in land surface-atmosphere water and energy exchanges

(4) Study the main principles of hydrological and climate forecast and prediction;

(5) Create frameworks to integrate climate and water data and information, identifying the changing needs of decision and policy makers (from individuals to federal agencies).

About Student's Evaluation

Is it the current evaluation strategy the appropriate (in terms of the percentages for each activity in class)?

Student evaluation is described in detail in [Appendix 1](#). The evaluation system was designed to balance the contributions the students put during the course. It has a strong weight on the Final Project considering this deliverable an integrative representation of the knowledge gained during the semester. It is aimed to test the process understanding (also tested in the midterm), application of tools (also tested in the assignments) and project development (developed from Assignment 2 and 5).

EVALUATION

NRES/METR 479/879 Hydroclimatology is a course, which home is the School of Natural Resources. NRES/METR 479/879 is an elective course in the undergraduate and graduate programs of Natural Resources and its major in Applied Climate Sciences and the Meteorology at the Earth and Atmospheric Sciences. NRES/METR 479/879 Hydroclimatology was taught during the spring of 2016. The limit of the class was set to 10 individuals and those were the ones registered from the Natural Resources (3 graduate and 1 undergraduate students), Meteorology (2 graduate and 1 undergraduate students), and Biological Systems Engineering (3 graduate students). The course started as an elective and out-of-the-department course for BSEN students. An initial goal of the present program was to create a course that could be cross-listed with BSEN at the undergraduate and graduate levels.

Documents in **Appendix 10** show the letter of intent written to the Undergraduate Studies Committee at the Biological Systems Engineering (UBSE). The process started by the acceptance of the School of Natural Resources' programs to cross-list the course as NRES/METR/BSEN 479/879 Hydroclimatology. Then, UBSE received the request during the Fall of 2015, open the discussion within their members and invited the lecturer to support the cross listing. Finally the committee decides to support the action and it is turn to SNR to run the final request to the College of Agriculture and Natural Resources. CASNR accepted the request in the spring of 2016.

The implementation of NRES/METR/BSEN 479/879 Hydroclimatology during the spring of 2016 evidenced the following:

- 1) Interest of NRES, METR and BSEN in the course
- 2) Areas of improvement of the course in format (Lecture, Discussion, Lab, and Final Project) to address NRES, METR, and BSEN key needs
- 3) Course content emphasize topics (land surface-atmospheric interactions and non-stationary planning perspectives for engineers)

The analyses that lead to the points above were kept simple and applied to Syllabus, Assignments, Midterm, Final Project, and Questionnaire. Those evaluations are summarized here and described as Interests, Format, and Content and analyzed in the Discussion.

INTERESTS

Interests can be defined by department's undergraduate and graduate programs, and by those related with students' programs. Information from syllabi is evaluated based on the previous and current objectives, content, and format of the course. The metrics associated are based on the identification of terms found in titles of textbooks and papers, abstracts, as well as contents in such documents. Also, the curricula of undergraduate and graduate programs in NRES-ACS, METR, and BSEN

were assessed based on the core and elective courses. Terms searched are: (a) Data; (b) Water Cycle; (c) Water Balance; (d) land surface-atmosphere interactions (processes and analyses); (e) climate processes (spatiotemporal scales); (f) modeling and forecast; (g) Extreme hydrometeorological and climate events. See [Appendix 11](#).

FORMAT

Questionnaire and grades, “BIG picture”

The format of the course is defined in the previous section as Lectures (10), Labs (10), Discussions (5), Assignments (5), Midterm, and Final Project. The instructor and students’ perspectives define the assessment on the format. The metrics for instructor’s perspective is based on the average (n=3 for BSEN and METR students and n=4 for NRES students) of the grades obtained in the main activities.

Assignments increase in complexity as the semester progresses and require from 1-hr work for assignment 1 to 6- to 8-hr work for Assignment 4 (which includes work of 3 Labs). Also, Assignments move gradually from generic data management to more oriented land surface-atmospheric interaction modeling. The Midterm integrates hydrological process understanding with analytical reasoning applied on hydroclimate system analyses. Final Project aims to identify the hydro climate systems’ understanding observed in the Concept Paper elaborated in the third week of class with respect to the final project.

On the other hand, the student’s perspective is taken from the last part of the report in Assignments 1 and 3, as well as from the final questionnaire ([Appendix 9](#)). The metrics to perform here are more qualitative. The evaluation will consider positive/negative responses to each of the components of the course. Here, Lectures, Labs, and Discussions will be evaluated.

CONTENT

Content refers to the topics covered in the class. The assessment articulates the metrics of the *Interests* section, results of the Questionnaire, and statistics of the Midterm questions. While metrics on keyword counting will evidence the relevant topic, how instruction effectively addressed those topics can be observed on the performance of the students in the Midterm (measured through the points obtained on relevant questions on the topics). The results can also be contrasted/integrated with those in the questionnaire to identify coincidences or differences. While coincidences can be measured on good performance in hydrologic-based questions, a key topic found in literature and emphasized in class. It is possible that students assessment was poor, leading to a possible poor performance of the instructor’s; or a good assessment, leading to a good topic for the class, and a good performance of the instructor. These criteria will be described in the next section and will use information located in [Appendix 7](#).

ANALYSES OF STUDENT LEARNING

Almost 12 years ago, I had a conversation with my PhD advisor (probably the first atmospheric modeler leading a department of Civil Engineering) about my academic profile. As engineers our conversation evidenced common interests on Water Resources planning and the role climate variability plays. He asked me about what would be my area of specialization. My answer was hydroclimatology. He nod and three years later I got my PhD in Civil Engineering, assessing the effect of climate variability and land use changes on streamflow generation. By that time a series of concerns were emerging in relation with the effect of climate change on infrastructure (i.e. water resources, energy generation, food production, among other economic drivers in the world). One of those challenges is the stationary assumption adopted by engineers, which seems no longer valid due to unpredictable climate and societal responses (i.e. resilience, mitigation, transformation). The present portfolio was aimed to support the cross-listing of NRES/METR 479/879 with the Biological Systems Engineering program 479/879 Hydroclimatology. A preliminary assessment aimed to identify the textbooks which title has the word Hydroclimatology. Two books were fined on-line and a single book in UNL's library. The table of content shows water, hydrology and climate, land surface as the most recurrent words. Also both Table of contents coincided with the proposed syllabus. However, the presented table of contents did not justify the interest of the community to address water and agricultural resources engineering (topics relevant in BSEN undergraduate and graduate programs). Then we quantify the keywords above in the abstracts of the top 10 cited articles which title included the word Hydroclimatology. The first result was six of the papers were published in Water Resources-journals (Water Resources Research, Journal of Hydrology and Hydrologic Processes); the remaining were geophysical journals (3) and Journal of Climate (1). The first paper published was in 1995 (Water Resources research) and the most cited in 2005 (Journal of Climate). However, no irrigation engineering, soil resources engineering, and agriculture engineering journal was observed. Merging all the abstracts the number of times the keywords were found is described on Table II. Nonetheless further analyses have to be implemented with a larger number of samples findings reflect, on one hand, the relevance of hydroclimatology for water resources engineers than for irrigation engineers. The word counting shows that the words with the highest numbers were Water, Hydrol, Evap (referred to evapotranspiration or evaporation) and soil (which could include soil physical properties and soil moisture). Climate is a low-counting word in the abstract which may indicate the relevance of this topic for water resources engineers and hydrologists, rather than for climatologists. On the other hand, the number of citations of the papers evaluated was relatively low, considering that some of the articles were published in the nineties (between 30 and 60 citations). Thus, these findings, evidence a tremendous opportunity for engineers in BSEN to start building professional and academic careers involving hydroclimate system's approaches.

TABLE II. Keyword counting.

	Title	Abstract
Water	3	44
Hydrol	0	19
Climate	1	8
Hydroclim	10	9
Land	0	8
ET	1	18
Soil	1	20
Moisture	1	10
Data	0	11

Last time NRES/METR 479/879 Hydroclimatology was taught was during spring of 2012. [Appendix 1](#) shows spring 2016 and 2012 to show the coincidences and differences. Four key changes can be summarized as follows:

- 1) Addition of 7 lectures (from 3 to 10), 10 Labs (and 5 Assignments), and 5 Discussions
- 2) Individualized Final Project meeting with students early in the semester
- 3) Addition of 2 invited lecturers (in Computer Sciences and Water Resources Engineering)
- 4) Land surface hydrology emphases and implementation of large scale modeling

FORMAT

From the instructor's perspective BSEN students outperform the rest of the class on every single activity. The differences in the final grades were 0.9 and 1.6 points with respect to METR and SNR students in a 0-10.0 scale. Grades on assignments show a good performance in all students. However, Assignment 4 showed the largest difference. Looking at [Appendix 5](#) (Assignments) Assignment 4 request students to applied previously gained knowledge on data processing and plotting; an additional request allow VIC-users and non-VIC-users two address three points, (a) area of study; (b) spatiotemporal representation of precipitation and other variable or state variable; and (c) a description that describe the methodology. However, students with grades below 9 did not address one of the three aspects mentioned above.

[Appendix 5](#) also illustrates one of the three Assignments (chosen randomly) with the top score to evidence the information requested. The Midterm was designed to cover gaps of knowledge of hydrology in METR students and provide a hydroclimatic context to temporally variable and spatially distributed variables used by SNR and BSEN students in previous (water resources and hydrology) courses. Also, it was envisioned to account just 25% of the final grade. BSEN students obtained 9.7, while METR and NRES students were 1 and 2 points below, respectively. The Final Project grade represents the cumulative effort of students along the semester. Assignments were designed in such a way that every homework

could contribute to the final project. METR students could perform below BSEN students because of Assignment 4. Two of the BSEN students integrated Assignments 1-4 and added analyses and their Final Project was a 1st draft of a paper. It is noteworthy that all students were encouraged to use this course to advance in their own research and *vice versa*. Just in one of the METR students was able to reach the level of quality delivered by BSEN students (the top Final Projects are shown in [Appendix 8](#)).

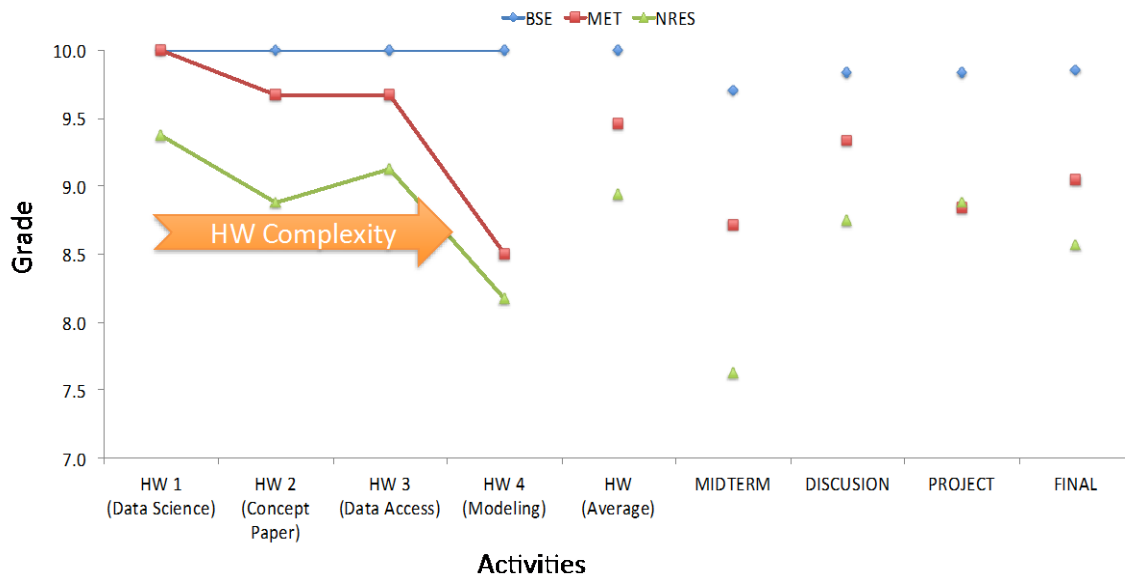

Figure 2. Activity grades by major (undergraduate and graduate students are included). Three BSE, 3 SNR and 3 METR students (1 SNR and 1 METR undergraduate students).

The Questionnaires are in [Appendix 9](#), and 6 out of 10 students filled them out (none of the METR students participated). In general the course was characterized helpful for research needs and strong in the following categories: analytical (6), computational (6), mathematical (4), statistical (5). While Assignments and Lectures have to be improved the Final Project was the best part of the course (5). In general the information provided in the course was relevant, updated and challenging. In summary, the analysis of the data collected as grades in activities along the semester and evaluations at the end of the course would be enhanced if METR students fill out the Questionnaire. The information provided can be considered relevant and covers the upper and lower performances in the instructor’s perspective. This “validate” the information regarding the analytical strength of the course and the value of the Final Project. Work has to be done toward the

improvement of the Lectures and Assignments. More elements regarding the content are described in the section below.

CONTENT

Literature (textbooks and cited papers) on Hydroclimatology shows the relevance of terms such as water, evaporation/Evapotranspiration, Soil (moisture), and Hydrology. These aspects were identified in the cited textbooks. The syllabi of the Spring 2012 and Spring 2016 addressed those topics in lectures and labs. However, the assessment in the section above evidences the need of better Lectures. The results from the Questionnaire (questions 12-15) show a consensus on the topics, knowledge of the teacher, available resources, and sequence. The remaining questions on Labs, Assignments and Final project are aligned with the positive assessment of the students. Thus, in order to identify a possible source of the problem in Lectures the Midterm is assessed. We identify that the greatest discrepancy in the grades occurs in questions 1 and 7. These questions required a understanding of the hydrological processes that govern the distribution of surface water and ground water in response to anthropogenic influences. These subjects could be clarified by coupling Lectures and Labs (Land Surface and Ground Water Hydrology and Hydrologic Modeling, respectively). The differences in the points obtained in these question varies from 0 to 5 in for half of the class (non-BSEN students) with an average of 2. This indicates that Surface and Groundwater hydrology should be emphasized in the following version of the course. Further work can be made by developing metrics to measure students' performance on specific components of the class through the assessment of the Final Project (written and oral, shown in [Appendix 8](#)).

PLANNED CHANGES

Based on the proposed evaluation and Analyses of Student Learning we propose following changes to NRES/METR/BSEN 479/879 Hydroclimatology.

FORMAT

Lectures and Assignments were rated low with respect to the rest of the activities. Based on the results from the Midterm and the Questionnaire hydrological processes have to be better articulated and explained. The proposed change envisions improvements in Lectures on Evapotranspiration, Soil Moisture, and Streamflow generation. These Lectures will be coupled with Land Surface Hydrology Labs (which were well rated). Considering that METR and NRES students were the most “harmed” in Assignment 4 (Labs 4-6), Land Surface Hydrologic modeling will be required to all students. A clear and justified substitution of this model by other modeling resource will be accepted, as far as it can address the theoretical and practical objectives requested in Lectures and Labs, respectively. It is also evident the need of a course in Meteorology for students in METR and NRES. For students in BSEN a course in hydrology will be equivalent, as far as the students review in such course the principles of formation of clouds and generation of precipitation. BSEN students take Thermodynamics and Fluid Dynamics, these courses will help to understand the physical principles involved in environmental modeling. Additionally, Discussions were well taken by students. I will introduce two discussions to the syllabus, merging the Water Balance Equation Class and the Climate System Class. A Discussion will be added Groundwater Analysis. Another Discussion will be added toward the end of the class to address concerns and questions about the Final Project. A Lab session on Modeling will be reduced, expecting to optimize the time we used this year. In terms of homeworks, Assignment 1 and 3 will be merged into Assignment 1 and Assignment 2 will be due during the 5th week of class. This change aims to (1) have a more integrative perspective of hydroclimatic data access and graphical display; and (2) have more hydroclimatic background information to develop a better Concept Paper. Final Project will due during the week before finals in two sessions. The final report will be due the day of the final.

CONTENT

Changes in content are expected. These changes will be in the first section of the course on Data Science and Access. Here, we will introduce some basic statistical concepts and tools. While statistical concepts will review frequency analyses and probability applied to climate and hydrologic sciences, described with examples developed in the literature, the lab will guide the student to reproduced those examples using MATLAB. The difference with respect to the precious coupling of

class-lab-discussion is that those forms were Lectures and the need of a problem-solution approach in class and in the lab will be implemented. It is expected that these activities will be run in teams. A second change in the syllabus is emphasis on evapotranspiration, soil moisture and streamflow. Two Lab sessions on Groundwater Modeling and Data Analyses will be removed formally. This year those sessions were already substituted with additional labs on land surface hydrologic modeling (LSHM). The decision is based on the course taught in Earth and Atmospheric Sciences and the need of additional sessions on LSHM. The lecture on Groundwater will continue.

CONCLUSIVE REMARKS

Now the Hydroclimatology course is NRES/METR/BSEN 479/879. The course was successfully cross-listed with Biological Systems Engineering Undergraduate and Graduate programs. A new challenge is to teach it every spring semester and attract undergraduate students in BSEN and continue a balanced registration in METR, NRES and BSEN graduate/undergraduate programs.

Projects presented by students all had an emphasis of a component of the water cycle and addressed how climate impact such component. The projects all had a water resources component of from local to sub-continental scales.

The non-stationary criteria in planning-type of projects were clearly identified in BSEN Final Projects. This aspect addressed the request made by the BSEN Undergraduate Curriculum Committee.

The syllabus evidences the use of techniques applied on hydroclimatic data science and hydroclimate systems' modeling. Access to different formats of data and the ability to manipulate and plot such data was achieved and is evidenced in the examples of Assignments 1 and 3. Modeling activities are evident in 80% of the Final Projects presented and in Assignment 4.

Eighty percent of the students integrated their research interests with the research proposed and presented as Final Project. The remaining 20% may "upgrade" their reports to a peer review paper.

A multidisciplinary perspective was achieved and is evident in every Final Project.

SUMMARY AND OVERALL ASSESSMENT

NRES/METR 479/879 Hydroclimatology was taught two times since the spring of 2012. This year the course was cross-listed with BSEN. Clear changes in the Format and Content were driven by the addition of BSEN undergraduate and graduate programs. These changes allowed the course to be more inclusive and opportune from many perspectives and challenges (i.e. growing interests on the effect of climate change on infrastructure, water resiliency, nexus water-food-energy, predictability of extreme hydrometeorological and climate events, food and water security, among many other topics). As NRES/METR/BSEN 479/879 students scientific and engineering perspectives allow them to interact and built strategies to advance the science of hydrocliamtology and develop technologies and planning strategies to reduce the effect of a changing climate on water availability.

The journey I started with instructors, colleagues and students during this academic year was highly fruitful. My perception of “teaching by teaching” changed to a new motivation of teaching for research and research for teaching. This multidimensionality in what the students learn and what I can implement in my lab of what my lab can contribute with to my classroom is also a form to optimize resources and become more productive. New ideas have emerged from this activity and now I am looking forward to start my course again and continue enhancing the data that the students graciously allowed me to collect. Also, I am planning to run the same approach in every single course I teach. I understand the quest toward more integrative teaching and research agendas across disciplines is steep. I consider this the first step toward achieving more integrative programs in our university.

Appendices

Appendix 1

NRES/METR/BSEN 479/879
Hydroclimatology
Spring 2016

Schedule: Lecture: T & TH 4-5:15PM. Room: Hardin Hall 163 (East Campus)

NOTE: This class is proposed to be cross-listed BSEN 479/879

INSTRUCTOR:

Faculty Instructors:

Francisco Munoz-Arriola
246 Chase Hall
Phone – Office: 472-0850
Email: fmunoz@unl.edu
Office Hours: Drop in or by appointment

Teaching Assistant:

TBD
TBD
Phone – Office: TBD
Email: TBD@huskers.unl.edu
Office Hours: Drop in or by appointment

Prerequisite

NRES 208 (Applied Climate Sciences), METR 200 (Weather and Climate), METR 370 (Basic and Applied Climatology); or AGEN/BSEN 350; or permission of instructor.

OBJECTIVES:

Following this course, students will:

- (1) Understand the processes that drive the water and climate systems, as well as their spatiotemporal scales;
- (2) Identify and characterize the availability and reliability of *in situ* and remote sensing data, modeling, and merged data used to track physical, biological/biogeochemical, and socioeconomic components of the global water system in a changing climate;
- (3) Study the main principles of “water-cycle” modeling;
- (4) Implement the use land surface hydrologic and groundwater models (as black boxes) to explore spatiotemporal scales of variability in groundwater-land surface-atmosphere interactions
- (5) Create frameworks to integrate climate and water data and information, identifying the changing needs of decision and policy makers (from individuals to federal agencies).

METHOD:

The course includes lectures, lab experiences, and refereed-literature reviews/discussions with home assignments and a final project.

REQUIRED TEXT:

Hydroclimatology: Perspectives and Applications, Marlyn L. Shelton, 2009, Cambridge University Press.

RECOMMENDED TEXTS:

Mesoscale Meteorological Modeling, Volume 98, Roger Pielke Sr, 2013, International Geophysics. Academic Press (3rd Edition)

Rainfall-runoff Modeling: A Premier, Keith Beven, 2012, Wiley-Blackwel (2nd Edition)

Physical Hydrology, S. Lawrence Dingman, 2002, Waveland Press (2nd Edition)

LECTURES/NOTES/ASSIGNMENTS:

(1) Lectures will be presented as PowerPoint/Key/Prezi presentations followed by group discussions. These presentations along with all other notes and assignments will be posted on Blackboard. (2) Labs will be run in SNR or BSE computational laboratories, which have access to the Holland Computing Center where accounts will be set up for each student. (3) Discussion of refereed papers will be done in the classroom at the end of each main topic (on data processing, modeling, and interdisciplinary applications).

HOMEWORK:

Homework assignments will be given on class and labs to provide students with experience solving practical problems in hydrology and as preparation for problems on the exams.

Final Project: Graduate students who are enrolled in NRES/METR/BSEN 879 will be required to complete a final project in oral and written formats, while undergraduate students will do an oral presentation of their final projects. Projects will consist of class presentation/report of her/his own research project findings especially placed in the context of topics previously discussed in class. Presentations must adhere to the requirements of professional seminar presentations. The objectives of this assignment are 1) to exemplify how topics previously discussed in class are associated with a broad range of research projects and subjects outside the classroom; 2) to foster public speaking in the undergraduate/graduate student – a skill required in any professional field; and 3) to promote the student's ability to convey her/his technologic and scientific expertise in a way that is understandable to educated but not expert audiences. If the student lacks a relevant research project, a review seminar on a topic to be agreed upon with the class instructors will be presented.

GRADING:

	Percent of grade	In general, the following grading system will apply:
Graded Homework (7)	35	A+ 97-100%
Examinations (1)	25	A 93-96
Project	30	A- 90-92
Class discussion	<u>10</u>	B+ 87-89
	100	B 83-86
		B- 80-82
		C+ 77-79
		C 73-76
		C- 70-72
		D+ 67-69
		D 63-66
		D- 60-62
		F <60

Class participation is expected. The instructor will especially call upon those who do not actively participate in class in efforts to promote participation from every student in class.

Missed examinations must be cleared with the instructor ahead of time. No make-up exams will be given to students that have not notified the instructor ahead of the absence.

Due dates will be given on homework and reports. **NO LATE HOMEWORK WILL BE ALLOWED.** Special circumstances regarding homework deadlines must be arranged with the instructor in advance when possible. All work should be well organized and neat. Poorly written reports will not be accepted. Spelling and grammar will be considered in grading reports. Since a significant portion of the course grade is based on class participation and graded homework and reports, students should place priority on timely preparation of high quality homework and be active participants in class.

Turn off your cell phone during class.

ATTENDANCE POLICY:

The attendance policy as listed in the schedule of classes for UNL will be adhered to. Students are responsible for the material presented in lecture or laboratory periods. It is your responsibility to acquire lecture notes, handouts or exercises for missed class periods.

CHEATING/PLAGIARISM:

Please review Section 4 of UNL's Student Code of Conduct for definitions and warnings against cheating and plagiarism. UNL's policy on Academic Dishonesty states that a student may receive a sanction as severe as removal from a course with a failing grade for any type of Academic Dishonesty. I will not tolerate cheating or plagiarism. If you are caught cheating or plagiarizing you will be removed from the course and receive a failing grade. Remember that

plagiarism goes beyond copying someone else's work "word-for-word". It includes using ideas without proper citation. It is essential, therefore, that you acknowledge the ideas of other scientists (including your classmates) in all of your written work and reports. Failing to properly cite ideas is as serious as copying your friend's homework.

SNR ACADEMIC DISHONESTY, POLICY APPEALS, AND GRADE APPEALS POLICY

Students are expected to adhere to guidelines concerning academic dishonesty outlined in Section 4.2 of University's Student Code of Conduct (<http://stuafs.unl.edu/ja/code/>). Students are encouraged to contact the instructor for clarification of these guidelines if they have questions or concerns. The SNR policy on Academic Dishonesty is available at <http://snr.unl.edu/employeeinfo/information/index-information-results.asp?submitwhat=submit&snrservices=checkbox>

ADA POLICIES

Students with disabilities are encouraged to contact the instructor for a confidential discussion of their individual needs for academic accommodation. It is the policy of the University of Nebraska-Lincoln to provide flexible and individualized accommodation to students with documented disabilities that may affect their ability to fully participate in course activities or to meet course requirements. To receive accommodation services, students must be registered with the Services for Students with Disabilities (SSD) office, 132 Canfield Administration, 472-3787 voice or TTY.

FIFTEENTH WEEK POLICY:

This course adheres to UNL's policy, previously referred to as "Dead Week Policy". The policy states:

"Final examinations for full semester classes are to be given ONLY at the regularly scheduled time as published in the Official Schedule of Classes or at another time DURING FINALS WEEK mutually agreeable to all concerned.

"The only examinations that may be given during the last week (15th week) of classes are: laboratory practical examinations, make-up or repeat examinations, and self-paced examinations. However, the following must be applied:

"Projects, papers, and speeches scheduled for completion during the last week (15th week) of classes must have been assigned in writing by the end of the eighth week. This stipulation refers to the project and its scope, but not the topic. Moreover, ALL requirements, except for the final exam, must be completed no later than Wednesday of the fifteenth week. However, if the instructor has assigned a project, paper, or speech by the eighth week to replace the final, then the project, paper, or speech may be completed any time in the 15th week or finals. The exception to this is a class meeting one day a week on a Thursday or Friday for which all policies/requirements are shifted to either a Thursday or Friday, respectively."

TENTATIVE COURSE OUTLINE FOR 2016 (Subject to change; dates are bases on the 2015 academic calendar):

Date	Topic	Recommended Reading	Assignments
1/14/14	Introduction	Lecture	
1/16/14	Introduction to the Water Cycle & Water Balance Equation	Lecture	
1/21/14	Climate System	Lecture	
1/23/14	Data Access	Lab	Homework 1 Data Science
1/28/14	Literature Review	Discussion	
1/30/14	Hydrologic variability & Precipitation	Lecture	Due Homework 1
2/4/14	Datasets	Lab	Homework 2 Spatiotemporal variation
2/6/14	Data Management, Uncertainty and Integration	Discussion	

2/11/14	Terrestrial Components	Lecture	Due Homework 2
2/13/14	Data Analysis	Lab	Homework 3 Time series and change analyses
2/18/14	Literature Review	Discussion	
2/20/14	Evapotranspiration	Lecture	Due Homework 3
2/25/14	Estimations of Water and Energy Fluxes	Lab	Homework 4 Land use change
2/27/14	Land use and greening	Discussion	
3/4/14	Groundwater	Lecture	Due Homework 4
3/6/14	Groundwater modeling/data analysis	Lab	
3/11/14	Groundwater modeling/data analysis	Lab	Homework 5 Ground water analyses
3/13/14	Groundwater and Climate	Discussion	

3/18/14	Spring Break		
3/20/14	Spring Break		
3/25/14	1 st Midterm		
3/27/14	Land surface Hydrology	Lecture	Due Homework 5
4/1/14	Hydrologic modeling	Lab	
4/3/14	Hydrologic modeling	Lab	Homework 6 Surface water analyses
4/8/14	Land surface- Atmosphere Interactions	Discussion	
4/10/14	Flood Modeling and Forecast	Lecture	Due Homework 6
4/15/14	Climate modeling Pre-processing	Lab	
4/17/14	Drought Modeling and Forecast	Lecture	

4/22/14	Climate modeling Post-processing	Lab	Homework 7 Ground water analyses
4/24/14	Flood and Drought Modeling and Forecast	Discussion	
4/29/14	Scientific Communication: Hydroclimatic Data Analytics and Synthesis	Lecture	Due Homework 7
5/1/14	Presentations		
5/5/14 to 5/9/14	Final Project (if needed)		

NRES 479/879: Hydroclimatology

Fall semester, 2012

Instructor Dr. John D. Lenters, Associate Professor
School of Natural Resources
Office: 723 Hardin Hall (east campus)
Phone: 304-0166; E-mail: jlenters2@unl.edu

Office Hours Generally available on Tuesday and Thursday
All other times by appointment

Class Schedule Tuesday/Thursday 2:15-3:45pm
209 Hardin Hall

Prerequisite NRES 208 (Applied Climate Sciences), METR 200 (Weather and Climate), or METR 370 (Basic and Applied Climatology); Or permission of instructor.

Course Description Study of the interaction between earth's climate and the hydrologic cycle, with an emphasis on energy and water fluxes at the land-atmosphere interface. Processes studied include atmospheric moisture transport, precipitation, evaporation, snowmelt, and runoff. Impacts of climate variability and change on the hydrologic cycle are also examined.

Learning Objectives This course is designed to provide students with an understanding of introductory and advanced topics in hydroclimatology. Specifically, upon completion of this course, students should be able to understand, describe, and explain:

- 1) The processes and equations governing atmospheric moisture distribution, transport, and convergence.
- 2) The processes and equations governing the surface energy and water balance.
- 3) The various climatic controls on evapotranspiration, snow cover, runoff, and soil moisture.
- 4) Land-atmosphere feedbacks such as precipitation recycling, snow/ice albedo, and vegetation dynamics.
- 5) The ways in which climate change is impacting the hydrologic cycle.
- 6) The "pan evaporation paradox" and its connection to climate change.
- 7) The impacts of climate change on various hydrologic processes (e.g., snowmelt, streamflow, drought, and extreme precipitation events).
- 8) Results from recent hydroclimatic studies as presented in the contemporary scientific literature.

Textbook There is no required textbook for this course – in part, because a standard textbook for hydroclimatology does not exist. Instead, required readings will be drawn from a variety of sources, including classic and contemporary journal articles in the fields of hydrometeorology, climatology, and hydrology, as well as textbooks on climatology and hydrology. These readings will either be provided online (i.e., through Blackboard – <http://my.unl.edu>) or through e-mail.

Grade Weighting	<u>Graduate students:</u>	<u>Undergraduates:</u>
	1) Research project (40%) 2) Exam (30%) 3) Discussion leadership / lecture (20%) 4) Class participation (10%)	None this semester

Grading Scale	90–100%:	A– / A / A+	60–70%:	D– / D / D+
	80–90%:	B– / B / B+	< 60%:	F
	70–80%:	C– / C / C+		

Research Project Students taking the class for graduate credit (i.e., at the 800-level) will be expected to propose, develop, and complete a research project on a topic related to hydroclimatology. The project must be an original piece of work that includes a thorough literature review, a careful and thought-provoking analysis (of data and/or model output), a written term paper summarizing the results, and an oral presentation to the rest of the class (given during final exam week). The written term paper will be graded in a series of “homeworks” that will – in total – comprise 20% of the semester grade. Another 20% will be made up of the final paper and oral presentation (i.e., 10% each), to total 40% for the research project.

Exam An exam will be administered toward the end of November. The exam will be based on a variety of “key concepts” that are identified during class discussions / lectures and compiled over the course of the semester. Prior to the exam, the key concepts will be posted on Blackboard for further review and discussion. Exam questions will test the students’ understanding of these key concepts, as well as their ability to synthesize the information and draw further scientific inferences related to hydroclimatology.

Discussion Leadership / Lecture It is often said that “One of the best ways to learn a subject is to teach it to others.” Graduate students in this class will be expected to do just that: Develop their critical reading, analysis, and discussion skills, as well as a thorough understanding of a topic, by leading the class in one 40-minute lecture, as well as one 40-minute discussion of an area of hydroclimatology (based on readings from the literature). Students are encouraged to propose specific journal articles for discussion and/or topics for their lecture, particularly those that may relate directly to their own graduate research. A grade will be assigned to each student based on their level of preparation, their ability to effectively summarize the article being discussed (or the topic being presented), their ability to convey a thorough understanding of the material to the rest of the class and address questions that are raised, and their effectiveness in leading class discussion. This last point is particularly important – the discussion sessions are meant to involve all students. So one of the primary tasks of the discussion leader is to draw input from everyone in class by raising thought-provoking questions and guiding a stimulating discussion. In other words, there must be evidence that learning is taking place. This requires preparation on the part of the discussion leader and participation by all students. The discussion leader is a facilitator of learning, not a “spoon-feeder of information.” The class lecture, however, is considered more formal and should involve the use of appropriate visual aids (e.g., Powerpoint).

Class Participation Most class periods will consist of an in-depth discussion of the previously assigned reading material. These discussions will be led by a discussion leader – a position that will be assigned on a rotating basis amongst the various graduate students and the instructor. Participation is expected from every student in class, and a portion of your final grade will be based on your level of class participation, as well as evidence that you have critically read the material and come to class prepared to participate (A=excellent, B=good, C=average, D=poor, or F=no participation).

ADA Statement Students with disabilities are encouraged to contact Christy Horn (472-8404) for a confidential discussion of their individual needs for academic accommodation. It is the policy of the University of Nebraska-Lincoln to provide flexible and individualized accommodation to students with documented disabilities that may affect their ability to fully participate in course activities or to meet course requirements. To receive accommodation services, students must be registered with the Services for Students with Disabilities (SSD) office, 132 Canfield Administration, 472-3787 voice or TTY.

Course calendar (subject to change):

Month	Day	Topic	Discussion leader(s)
Sept.	4	First class: Introductions, course layout	Lenters
	6	Introduction to energy / water balance methods	Lenters
	11-27	Out-of-class projects	
Oct.	2	Out-of-class projects	
	4	Evaporation trends / potential ET / pan paradox	Lenters
	9-11	Out-of-class projects	
	16	No class: Fall break	
	18-23	Out-of-class projects	
	25	Discussion of key literature	Seth
	30	Discussion of key literature	Colin / Juan
Nov.	1	Discussion of key literature	Tracie / Chris
	6	Presentations of preliminary project results	Seth, Colin, Juan
	8-13	Out-of-class projects	
	15	Preliminary project results (2:45-4:00pm)	Tracie, Chris
	20	No class: Thanksgiving break	
	27	Lectures (2:15-3:45pm)	Seth / Colin
	28	Lectures (2:30-4:30pm)	Juan / Tracie / Chris
	29	Semester exam (2:15-3:45pm)	
Dec.	4-6	Out-of-class projects	
	13	Final exam week: Project presentations	

Appendix 2

Table Ia. Courses for the undergraduate and graduate program in Meteorology at the Earth and Atmospheric Sciences Department and the Natural Resources' Applied Climate Sciences major at the School of Natural Resources. Biological Systems Engineering undergraduate and Masters and Biological Engineering PhD programs lack of climate/meteorological courses.

METR	Description	Prerequisites
Weather and Climate METR 100	Physical behavior of the atmosphere; elements of weather and climate and their distribution over the earth. Weather map analysis and forecasting. Atmospheric circulation, precipitation processes, severe weather, air pollution, and the use of weather radar. Concepts of weather forecasting.	MATH 101
Severe and Unusual Weather METR 140	Meteorological basics to help understand ice storms, blizzards, tornadoes, hurricanes, flooding, droughts, and other unusual weather.	MATH 101
Environment, Energy, and Climate Change	Conceptual process of climate change, environmental quality and earth energy.	
Introduction to Atmospheric Science	Conceptual foundations for synoptic and dynamic meteorology. Meteorological data analysis, the dynamics of atmospheric motions, and atmospheric thermodynamics.	MATH 106/106B/108H METR 100 PHYS 211/211H
Atmospheric Thermodynamics	Basic thermodynamic concepts relevant to atmospheric processes, atmospheric stability, and cloud and precipitation micro-physics.	CSCE 155N; METR 205; MATH 107 or 109H
Dynamic Meteorology I	Equations of thermodynamics, momentum, and continuity derived and applied to atmospheric motion. Energy conservation, flows, and conversions.	CSCE 155N; MATH 208/208H; METR 205; PHYS 211/211H.
Dynamic Meteorology II	Applications of the principles of dynamic meteorology to the problems of forecasting and meteorological problems.	CSCE 155N; MATH 221/821; METR 311; PHYS 211/211H.
Physical Meteorology	Physical principles that provide the foundation for meteorology. Absorption, scattering, and transmission of radiation in the atmosphere, atmospheric optics, atmospheric electricity, and lightning.	CSCE 155N; METR 205; PHYS 212/212H.
Synoptic Meteorology	Dynamic and thermodynamic concepts and principles applied to synoptic-scale weather forecasting. Dynamics, energetics, structure, evolution, and motion of extra-tropical cyclones. Meteorological communications, interpretation and analysis of weather maps, and thermodynamic diagrams.	METR 223.
Basic and Applied	Processes that give rise to spatial and temporal differences in climate. Various interrelationships	METR 100.

Climatology	between humans and climate. Influence of climate on building styles, the economy, water resources, human health, and society. Humans' inadvertent and purposeful modification of the atmosphere.	
Microclimate: The Biological Environment	Physical factors that create the biological environment. Radiation and energy balances of earth's surfaces, terrestrial and marine. Temperature, humidity, and wind regimes near the surface. Control of the physical environment through irrigation, windbreaks, frost protection, manipulation of light, and radiation. Applications to air pollution research. Instruments for measuring environmental conditions and remote sensing of the environment.	
General Circulation of the Atmosphere	Development of the atmospheric circulation regimes, from planetary scale (e.g., the planetary waves) to synoptic scale (e.g., the cyclones and anticyclones) and mesoscale, their seasonal variations, and their roles in horizontal and vertical energy and water transports and budgets in the Earth system.	MATH 106 or 108H; METR 205 and 475/875; PHYS 211 or 211H; PHYS 221.
Cloud Physics	Buoyancy and parcel mixing, cloud physics instrumentation, the role of aerosols in precipitation processes, growth of liquid cloud droplets/raindrops/ice crystals, processes associated with falling precipitation particles, drop size distributions and their moments, applications to convection, and parameterizations of cloud microphysical processes for numerical modeling applications.	METR 223 and METR 323
Air Pollution	Basic processes (e.g., emission, transport, first-order chemical reaction, and deposition) associated with air pollution and their combination with meteorology for air quality forecasting. Environmental topics: acid rain; smog; air pollution; ozone hole; greenhouse gases; aerosols; long-range transport; civic regulations and international treaties on air pollution; and climate change.	METR and CHEM 109.
Boundary-layer Meteorology	Basic concepts of atmospheric turbulence and fundamental dynamics, thermodynamics, and structure of the atmospheric boundary layer are discussed. Atmospheric boundary layer parameterizations used in modern weather and climate models are presented.	METR 205, METR 223; MATH 208/MATH 208H or MATH 109H; PHYS 211/PHYS 211H.
Advanced Synoptic Meteorology-Climatology	Analysis and forecasting of subsynoptic-scale weather systems. Convection, thunderstorm models, severe local storm forecasting techniques, mesoscale convective complexes, vertical cross-sections, isentropic analysis, and weather radar.	METR 341.
Severe Storms Meteorology-Climatology	Dynamics of various types of severe weather (blizzards, flash floods, lightning, thunderstorms and winter and summer tornado outbreaks). Interpretation of the numerical and statistical models utilized to forecast these phenomena. Synoptic case studies of severe weather occurrences. Recent research on severe weather.	METR 311, METR 341
Mesoscale Meteorology	Dynamics and conceptual models of mesoscale meteorological phenomena and processes.	METR 311
Broadcast Meteorology	Information about the history and current status of broadcast meteorology and related technology. Procedures and requirements to obtain Professional Society certification/seal in Broadcast Meteorology. Address on air requirements mandated by the Federal FCC rules and regulations and	METR 100

	social impacts of broadcast meteorology. Opportunity to gain experience in presenting weather information through various media outlets, including the use of chromakey technology and social media.	
Broadcast Meteorology Practicum	Produce weather presentations worthy of airing live during Star City News. Learn how to develop weather presentations for production, including development of graphics, lead ins and promos. One-on-one critiquing/coaching to improve the presentation and content of the presentation will also take place throughout the semester.	METR 446 or METR 447
Climate and Society	Impact of climate and extreme climatic events on society and societal responses to those events. Global in scope and interdisciplinary.	METR 100 or NRES 370
Statistical Analysis of Atmospheric Data	Application of univariate statistics, hypothesis testing, statistical forecasting, forecast verification, time-series analysis, principal component analysis, and cluster/multivariate analysis to atmospheric data for different applications in the atmospheric sciences (from short-term weather forecast to long-term climate prediction).	METR and MATH 107/107H.
Radar Meteorology	The fundamental principles of weather radars and the basic application of these principles.	METR 323.
Satellite Meteorology	Concepts and principles related to meteorological observations from satellites. Applications for weather analysis and forecasting.	METR 223.
Satellite Remote Sensing of Atmosphere	Principles of atmospheric radiation and techniques for satellite image processing. Application of data calibration, image registration and enhancement, noise filtering and multi-spectral classification of satellite imageries. Survey of various satellite sensors used for monitoring different atmospheric processes and constituents.	METR 323.
Bio-Atmospheric Instrumentation	Discussion and practical application of principles and practices of measuring meteorological and related variables near the earth's surface including temperature, humidity, precipitation, pressure, radiation and wind. Performance characteristics of sensors and modern data collection methods are discussed and evaluated.	MATH 106; PHYS-4 HRS
The Climate System: Analysis and Prediction	Maintenance of the climate system and climate change over time. Global budgets of energy, water, and momentum and their balance. Development of simple, physically-based models of climate and of climate change.	
Tropical Meteorology	Atmospheric phenomena unique to the tropics, and their connection to the global circulation.	METR 223 and METR 311.
Physical Climatology	Global energy and water balance regimes of the earth and its atmosphere. Utilization of physical laws to reveal causes and effects of interrelationships in the climatic system.	METR 205.
Regional Climatology	Regional differentiation of the climates of the earth on both a descriptive and dynamic basis. The chief systems of climatic classification.	NRES/METR 370.
Hydroclimatology	Interaction between earth's climate and the hydrologic cycle. Energy and water fluxes at the land-atmosphere interface. Atmospheric moisture transport, precipitation, evaporation, snowmelt, and runoff. Impacts of climate variability and change on the hydrologic cycle.	NRES 208 or METR 100 or METR/NRES 370.
Global Climate	Elements of climate systems, El Nino/LaNina cycle and monsoons, natural variability of climate on	MATH

Change	interannual and interdecadal scales. Paleoclimate, and future climate, developed climate change scenarios and climate change impacts on natural resources and the environment.	106/106B/106H; 5 hrs PHYS; METR 475/875.
Earth's Climate Past, Present, Future	How the Earth's climate has varied and the forcing mechanisms related to those changes. Themes that reappear through Earth's climate history and into the future; causes of climate change; the natural response times of the multiple components; and the role of greenhouse gases within the climate system at differing time scales.	METR or 6 hrs GEOL.

Table Ib. Courses for the undergraduate and graduate program in Meteorology at the Earth and Atmospheric Sciences Department and the Natural Resources' Applied Climate Sciences major at the School of Natural Resources. Biological Systems Engineering undergraduate and Masters and Biological Engineering PhD programs lack of climate/meteorological courses.

	Meteorology	
Weather and Climate METR 100	Physical behavior of the atmosphere; elements of weather and climate and their distribution over the earth. Weather map analysis and forecasting. Atmospheric circulation, precipitation processes, severe weather, air pollution, and the use of weather radar. Concepts of weather forecasting.	MATH 101
Introduction to Atmospheric Science	Conceptual foundations for synoptic and dynamic meteorology. Meteorological data analysis, the dynamics of atmospheric motions, and atmospheric thermodynamics.	MATH 106/106B/108H METR 100 PHYS 211/211H
Statistical Analysis of Atmospheric Data	Application of univariate statistics, hypothesis testing, statistical forecasting, forecast verification, time-series analysis, principal component analysis, and cluster/multivariate analysis to atmospheric data for different applications in the atmospheric sciences (from short-term weather forecast to long-term climate prediction).	METR and MATH 107/107H.
The Climate System: Analysis and Prediction	Maintenance of the climate system and climate change over time. Global budgets of energy, water, and momentum and their balance. Development of simple, physically-based models of climate and of climate change.	
Global Climate Change	Elements of climate systems, El Nino/LaNina cycle and monsoons, natural variability of climate on interannual and interdecadal scales. Paleoclimate, and future climate, developed climate change scenarios and climate change impacts on natural resources and the environment.	MATH 106/106B/106H; 5 hrs PHYS; METR 475/875.
Hydroclimatology	Interaction between earth's climate and the hydrologic cycle. Energy and water fluxes at the	NRES 208 or METR 100 or METR/NRES 370.

	land-atmosphere interface. Atmospheric moisture transport, precipitation, evaporation, snowmelt, and runoff. Impacts of climate variability and change on the hydrologic cycle.	
Earth's Climate Past, Present, Future	How the Earth's climate has varied and the forcing mechanisms related to those changes. Themes that reappear through Earth's climate history and into the future; causes of climate change; the natural response times of the multiple components; and the role of greenhouse gases within the climate system at differing time scales.	METR or 6 hrs GEOL.
Physical Climatology	Global energy and water balance regimes of the earth and its atmosphere. Utilization of physical laws to reveal causes and effects of interrelationships in the climatic system.	METR 205.
	Natural Resources	
Basic and Applied Climatology	Processes that give rise to spatial and temporal differences in climate. Various interrelationships between humans and climate. Influence of climate on building styles, the economy, water resources, human health, and society. Humans' inadvertent and purposeful modification of the atmosphere.	METR 200
Microclimate: The Biological Environment	The physical factors that create the biological environment. Radiation and energy balances of earth's surfaces, terrestrial, and marine. Temperature, humidity, and wind regimes near the surface. Control of the physical environment through irrigation, windbreaks, frost protection, manipulation of light and radiation. Applications to air pollution research. Instruments for measuring environmental conditions and remote sensing of the environment.	MATH 106 or equivalent, 5 hrs physics
Bio-Atmospheric Instrumentation	Discussion and practical application of principles and practices of measuring meteorological and related variables near the earth's surface including temperature, humidity, precipitation, pressure, radiation and wind.	MATH 106; PHYS-4 HRS

	Performance characteristics of sensors and modern data collection methods are discussed and evaluated.	
Climate and Society	Impact of climate and extreme climatic events on society and societal responses to those events. Global in scope and interdisciplinary.	METR 100 or NRES 370
Regional Climatology	Regional differentiation of the climates of the earth on both a descriptive and dynamic basis. The chief systems of climatic classification.	NRES/METR 370.
Applied Climate Sciences	Role of the atmosphere in the natural resource system. Solar radiation, water, wind and energy, hazards and risk in the plant soil atmosphere system. Role of weather and climate in crop zones, land use, and wildlife habitat.	
	Additional Degree Requirements	
Introduction to Agriculture, and Natural Resource Systems	Agricultural and natural resource systems. The interrelationship and the impact of increased human involvement on these systems.	Introduction to Agricultural and Natural Resource Systems (LIBR 110A, NRES 103) (3 cr I, II) Lec 2, rct 1.
Introduction to Geospatial Information Sciences	Introduction to the theory and applications of geospatial information technology. Remote sensing, GPS data collection, GIS data types, editing GIS data, and spatial data analysis with emphasis on applications to natural resources using a problem based learning format.	Introduction to Geospatial Information Sciences (GEOG 312) (3 cr II) Lec 2, lab 2. Prereq: Junior standing; basic computer skills (spreadsheets, word processors, data and file management).
Introduction to Geographic Information Systems	Introduction to conceptual foundations and applications of computer-based geographic information systems (GIS). GIS database development, spatial data analysis, spatial modeling, GIS implementation and administration.	Lec 3, lab 2. Lab exercises provide experience with GIS software
Introduction to Remote Sensing	Introduction to remote sensing of the earth from aerial and satellite platforms. Aerial photography, multispectral scanning, thermal imaging and microwave remote sensing techniques. Physical foundations of remote sensing using electromagnetic energy, energy-matter interactions, techniques employed in data acquisition and methods of image analysis. Weekly laboratory provides practical experience	9 hrs earth science or natural resource sciences including GEOG 150 and 152, or 155.

	in visual and digital interpretation of aerial photography, satellite imagery, thermal and radar imagery. Applications in geographic, agricultural, environmental and natural resources analyses.	
Introduction to Water Science	Survey of the water science from the perspective of both natural and social sciences. Water budget, precipitation, evapotranspiration, runoff and stream flow, groundwater, water quality parameters, economics of water, water policy, water law and water politics.	

Appendix 3

Lecture 3: Water Cycle, Water Balance & Data Hydroclimatology NRES/METR/*BGEN 479/879

Francisco Munoz-Arriola^{1,2,3,4,5}

¹Biological Systems Engineering Department

²School of Natural Resources

³Earth and Atmospheric Sciences Department

⁴Robert B. Daugherty Water for Food Institute- Fellow

⁵United States Geological Survey-Volunteer for Science

January 21th 2016

Outline

- Previous Class
 - Class-administration
 - Common Interests
 - Introduction
 - Scales
 - Tools
 - Extreme Hydrometeorological and Climate Events

The Scales

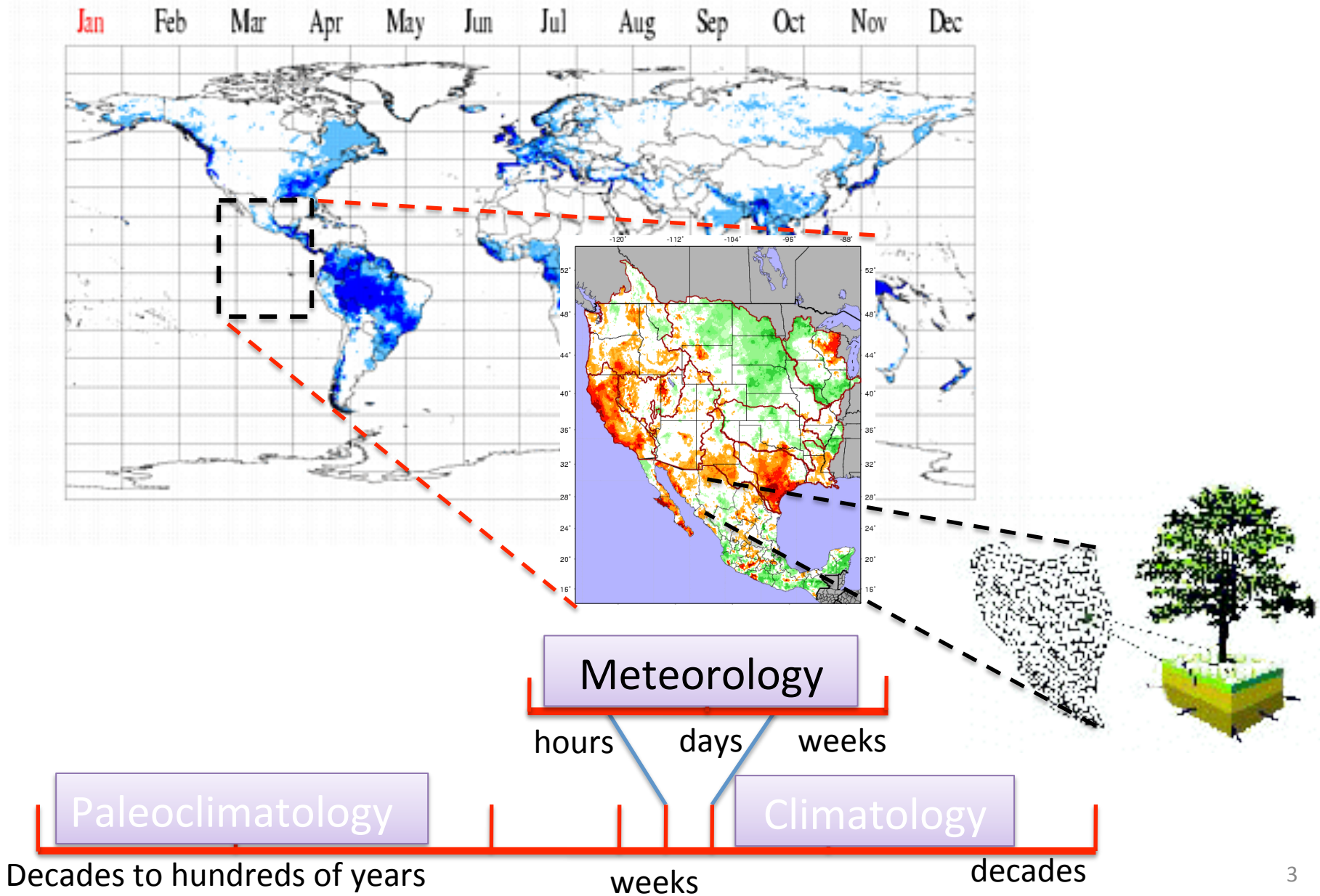

Space and Time Process Scales

- 1) Human environments, floods
- 2) Droughts
- 3) Climate Change
- 4) Water supply, landscape productivity
- 5) Agricultural productivity
- 6) Transport process operate

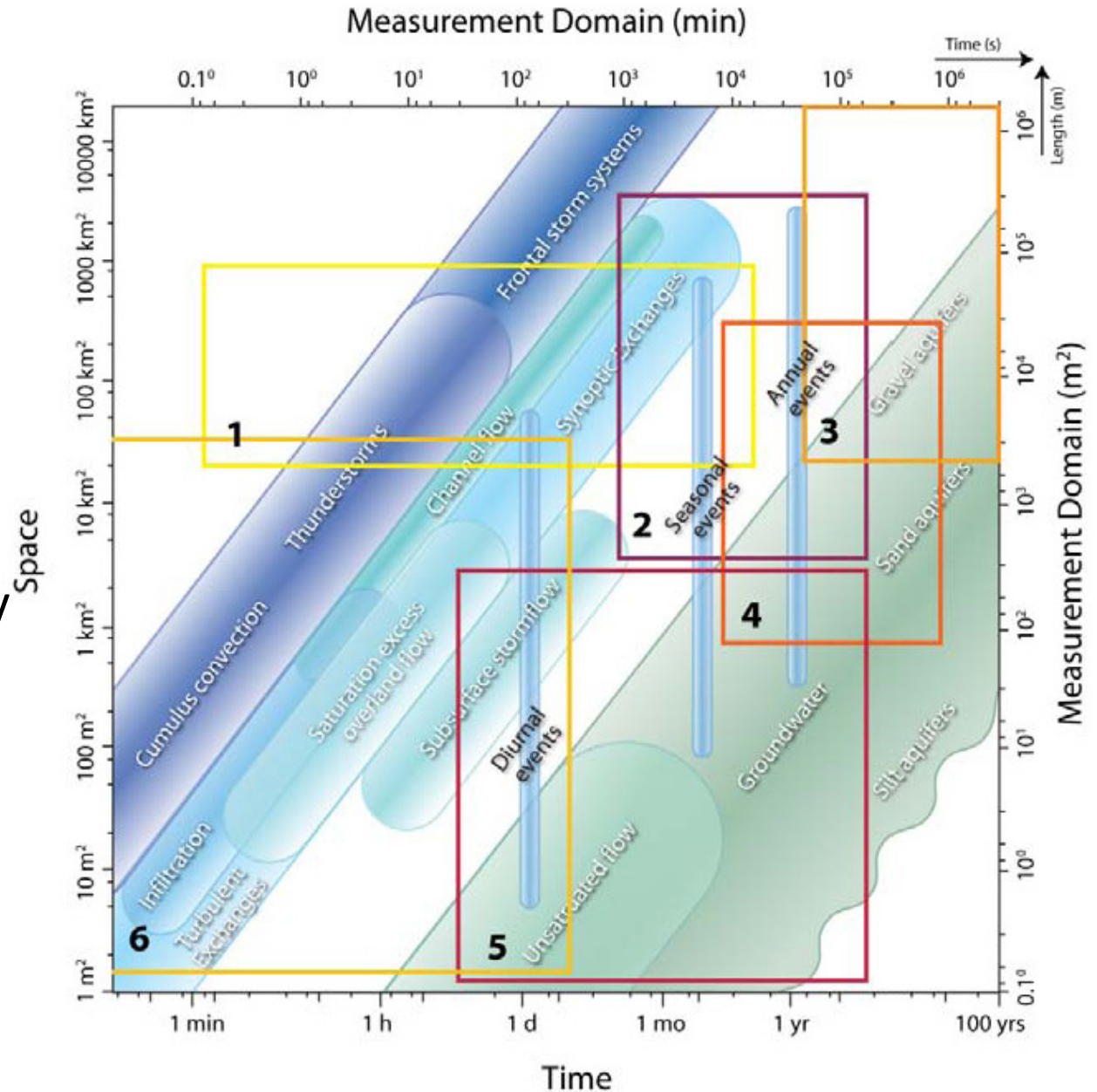

Sensor-operation Scales

1) X band

2) Lidar

3) Large-scale
scintillometry

4) Eddy covariance and
isotope sensor

5) Network sensors

6) time-domain
reflectometry and
Ground Penetration
Radar operate

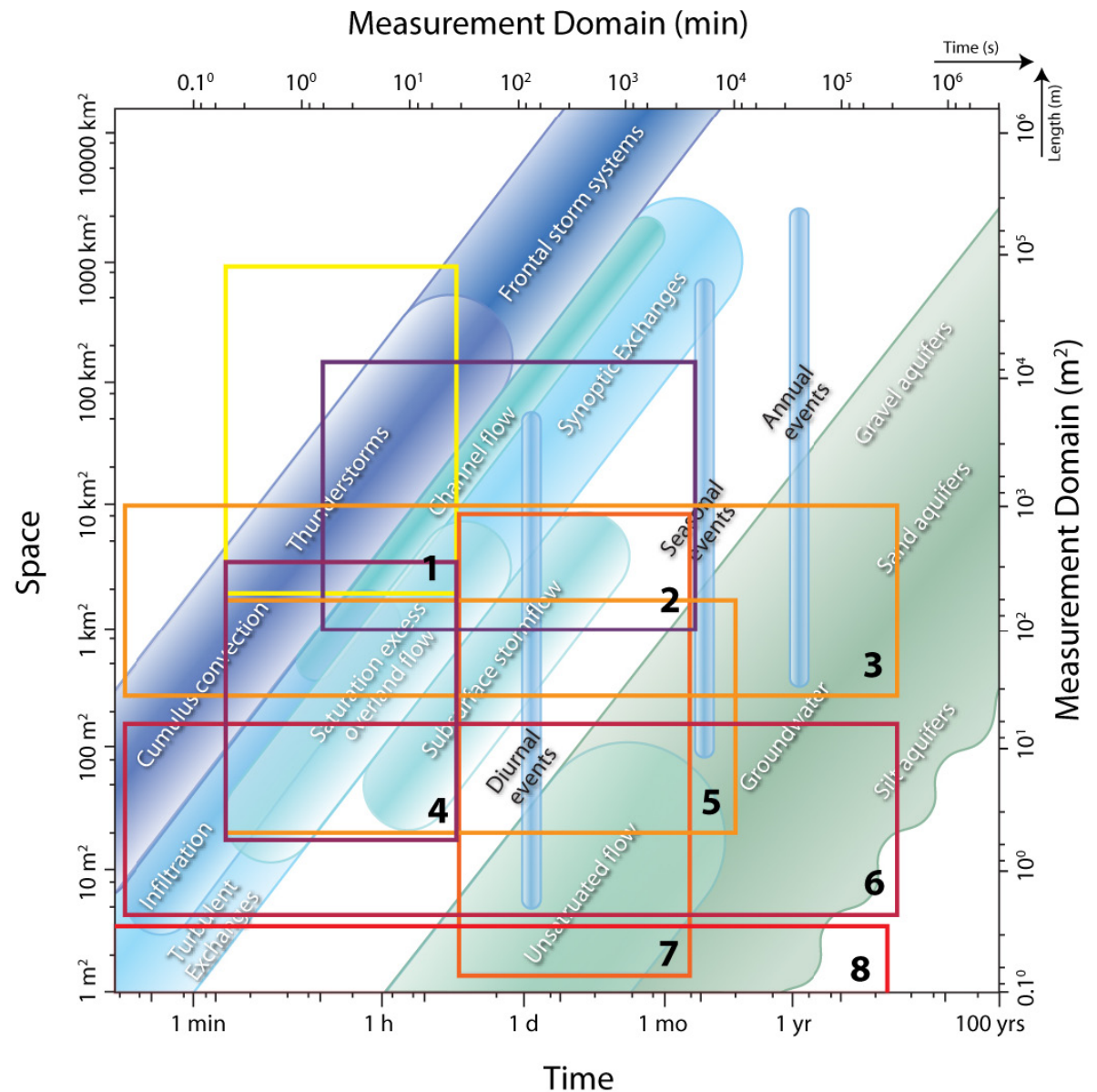

Tools

Remote Sensing

Polar Orbits

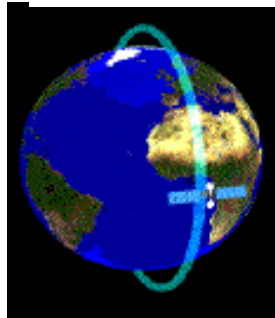

Geosynchronous Orbits

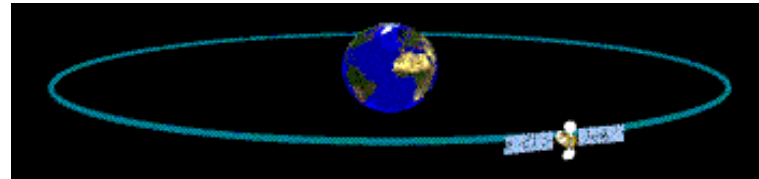

Modeling

in situ measurements



Outline

- Lab 2-Lecture
- Objectives
 - Extreme Hydrometeorological and Climate Events
 - Challenges
- Water Cycle
- Water Balance Equation
- Introduction to Data
- Take-home message

Extreme Hydrometeorological and Climate Events (1980-2012)

Number

1 200

21000 Loss events

2.3 million fatalities

1 000

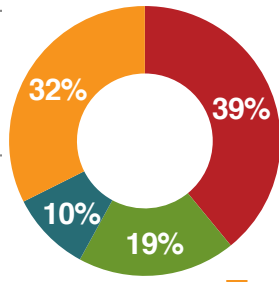
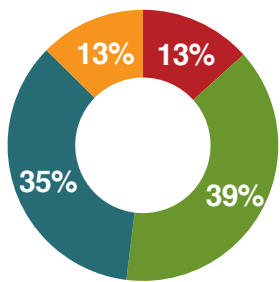

800

600

400

200

1980

1982

1984

1986

1988

1990

1992

1994

1996

1998

2000

2002

2004

2006

2008

2010

2012

Geophysical events
(Earthquake, tsunami,
volcanic eruption)

Meteorological events
(Storm)

Hydrological events
(Flood, mass
movement)

Climatological events
(Extreme temperature,
drought, forest fire)

Munich RE (2013)

Natural Catastrophes

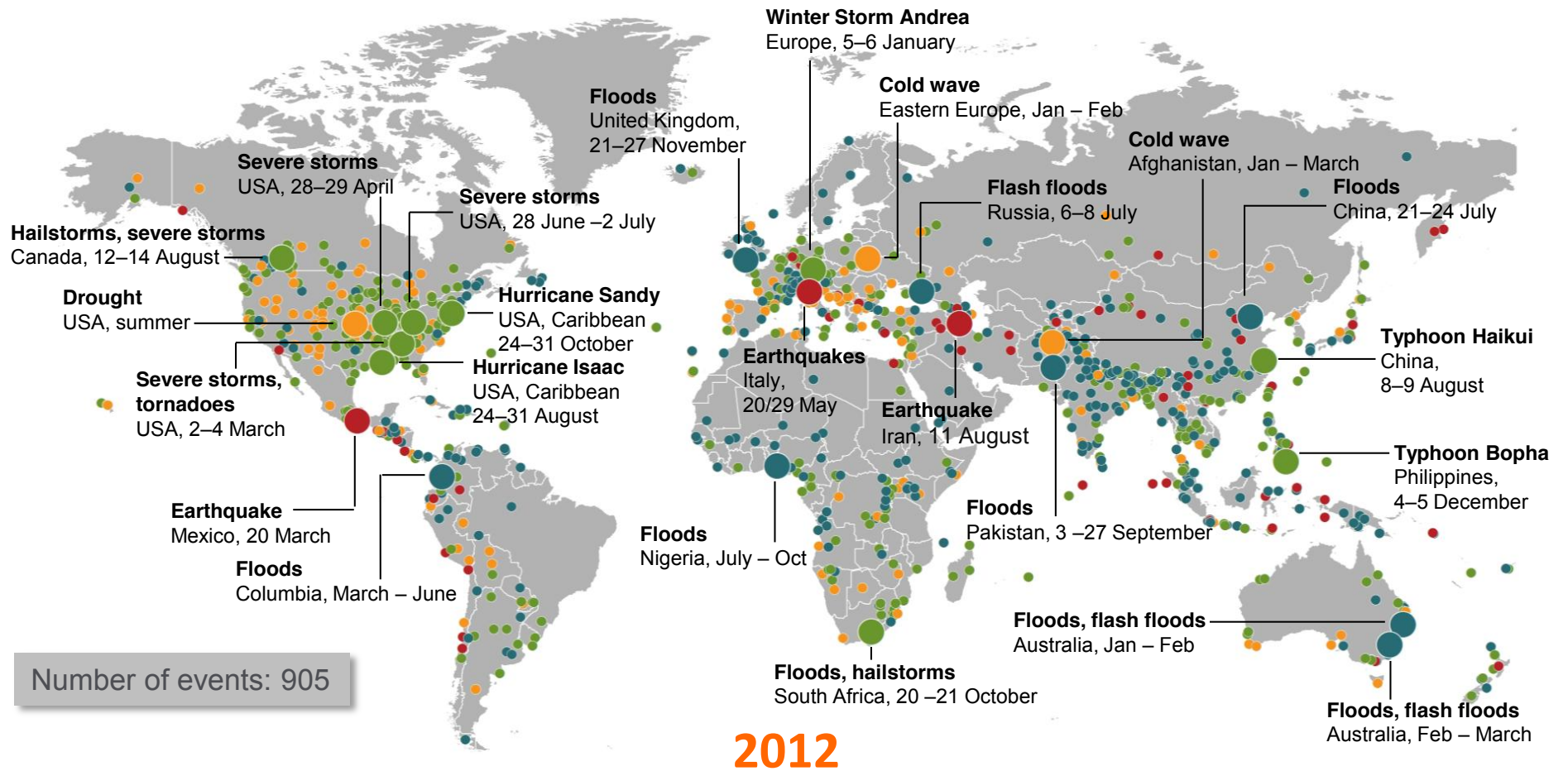

Number of events: 905

2012

- Natural catastrophes
- Selection of significant Natural catastrophes
- Geophysical events (earthquake, tsunami, volcanic activity)
- Meteorological events (storm)
- Hydrological events (flood, mass movement)
- Climatological events (extreme temperature, drought, wildfire)

1993 Flood Event

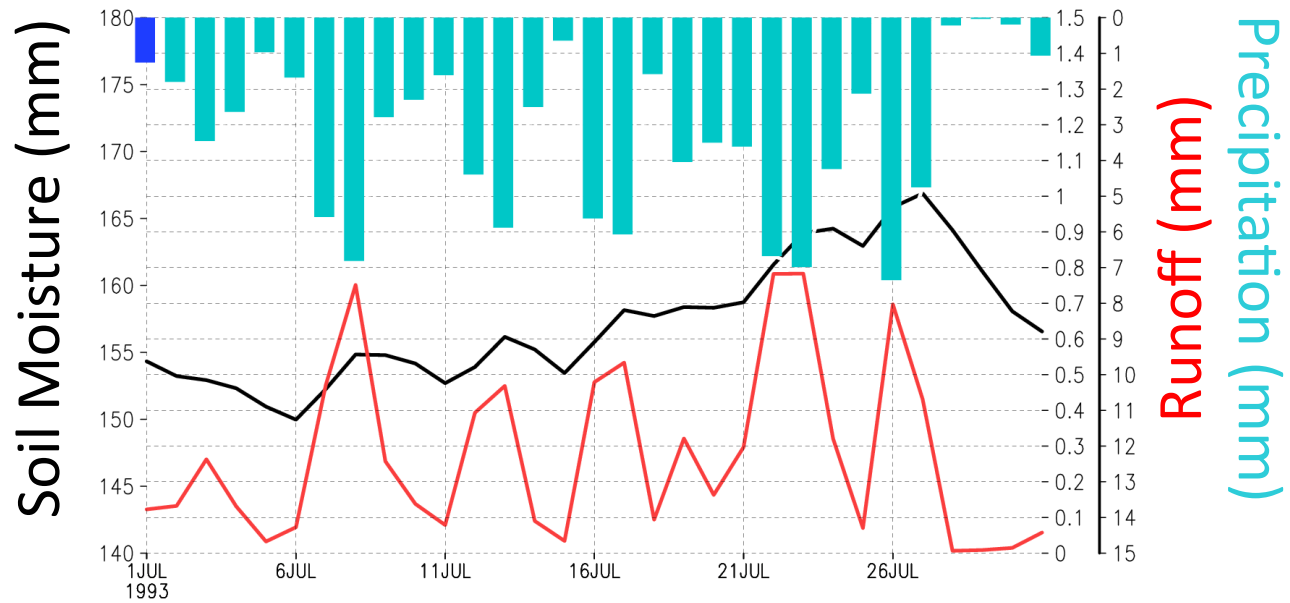
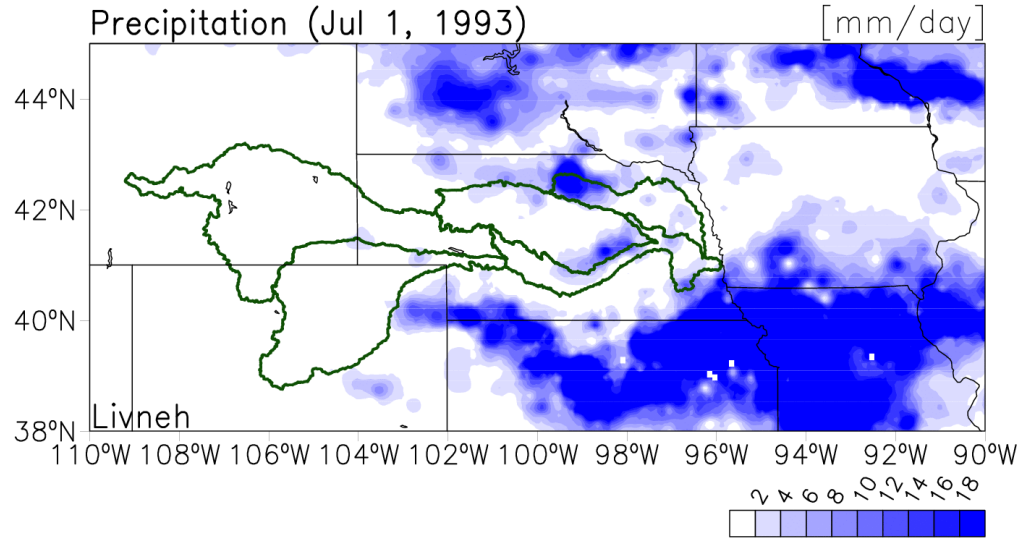

Agricultural Drought

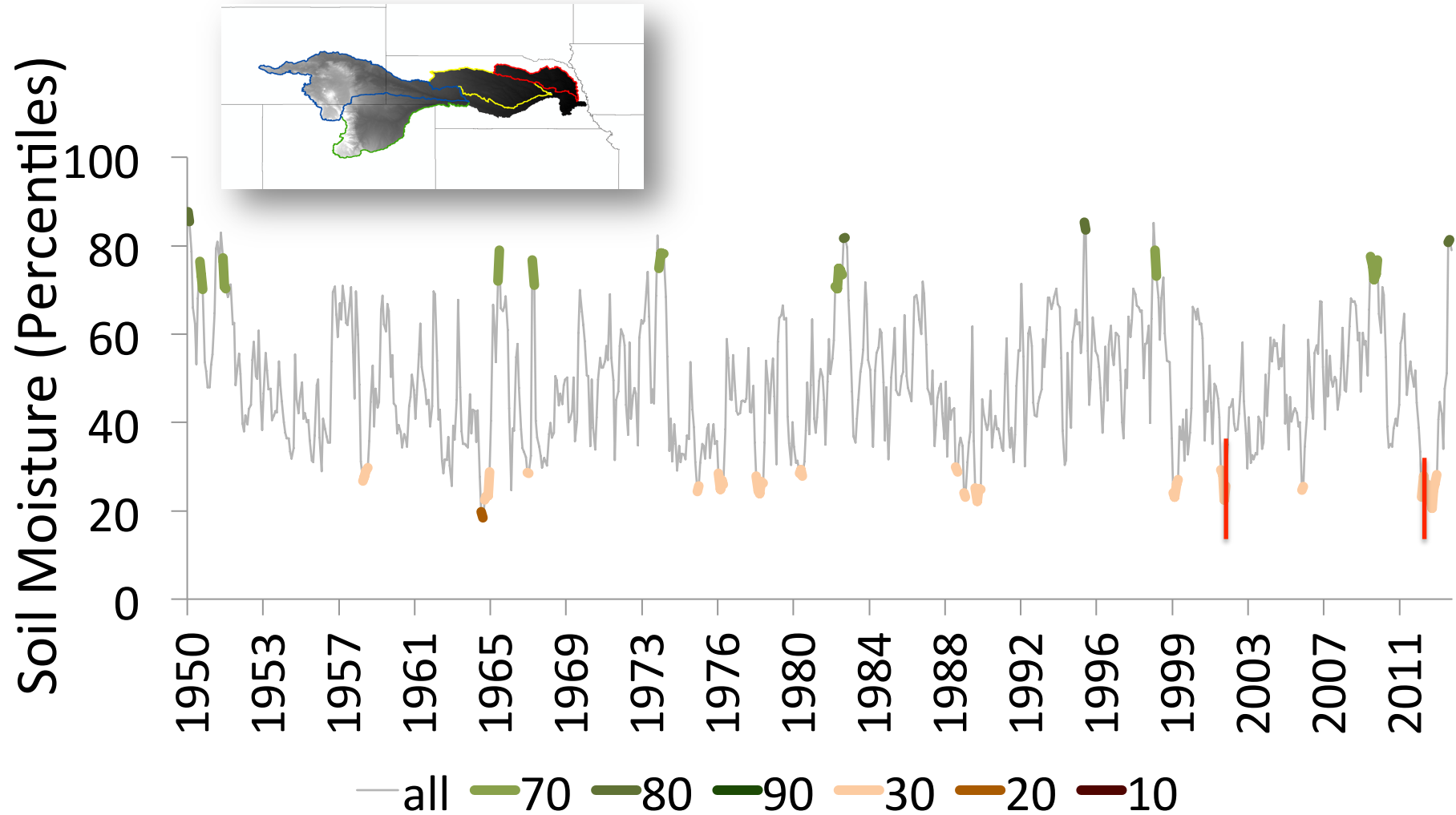

e.g. 2002 and 2011 Events

2012 Drought (Genesis, Evolution and Break)

Precipitation

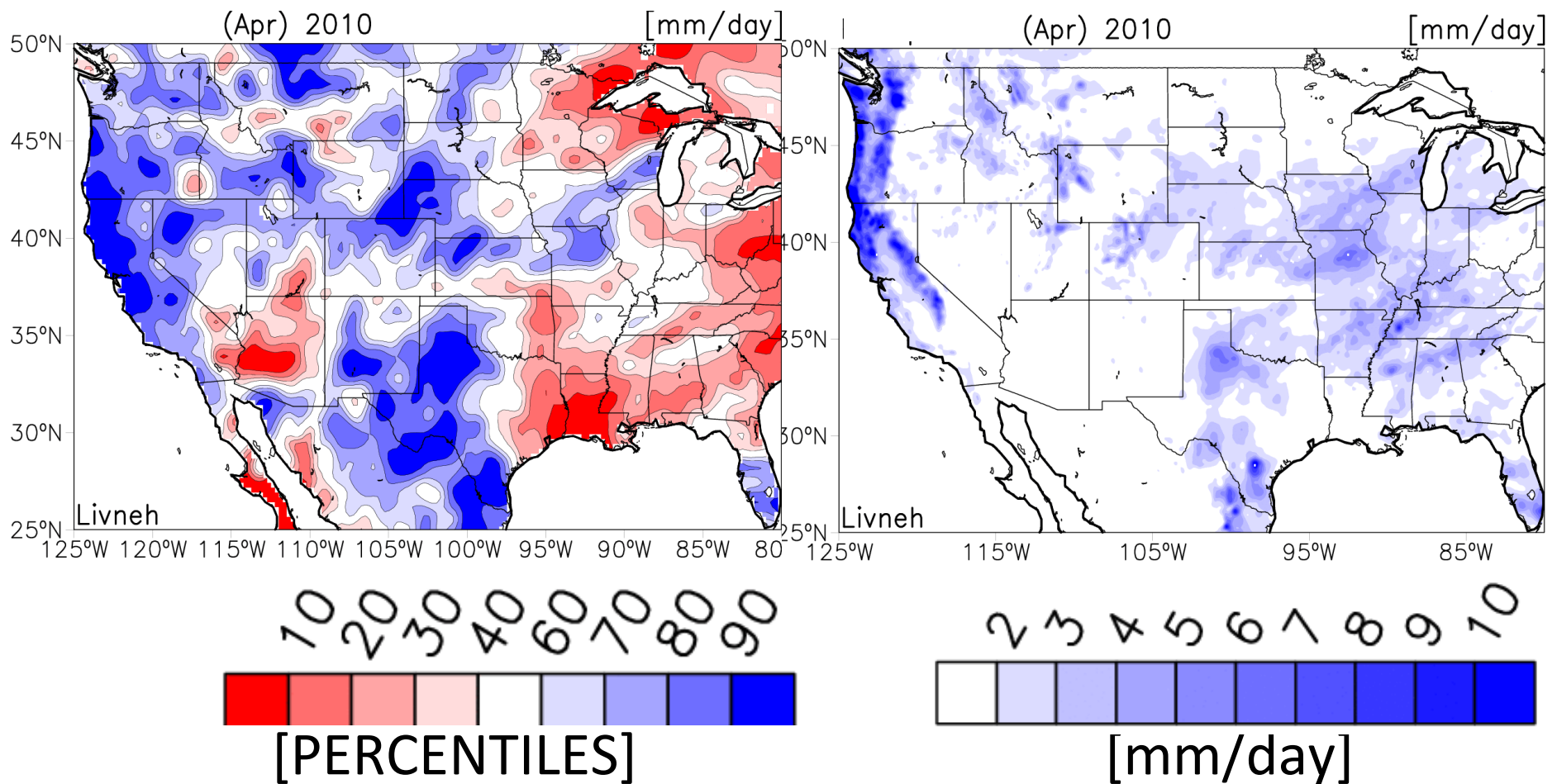

Challenges

Earth's System Boundaries

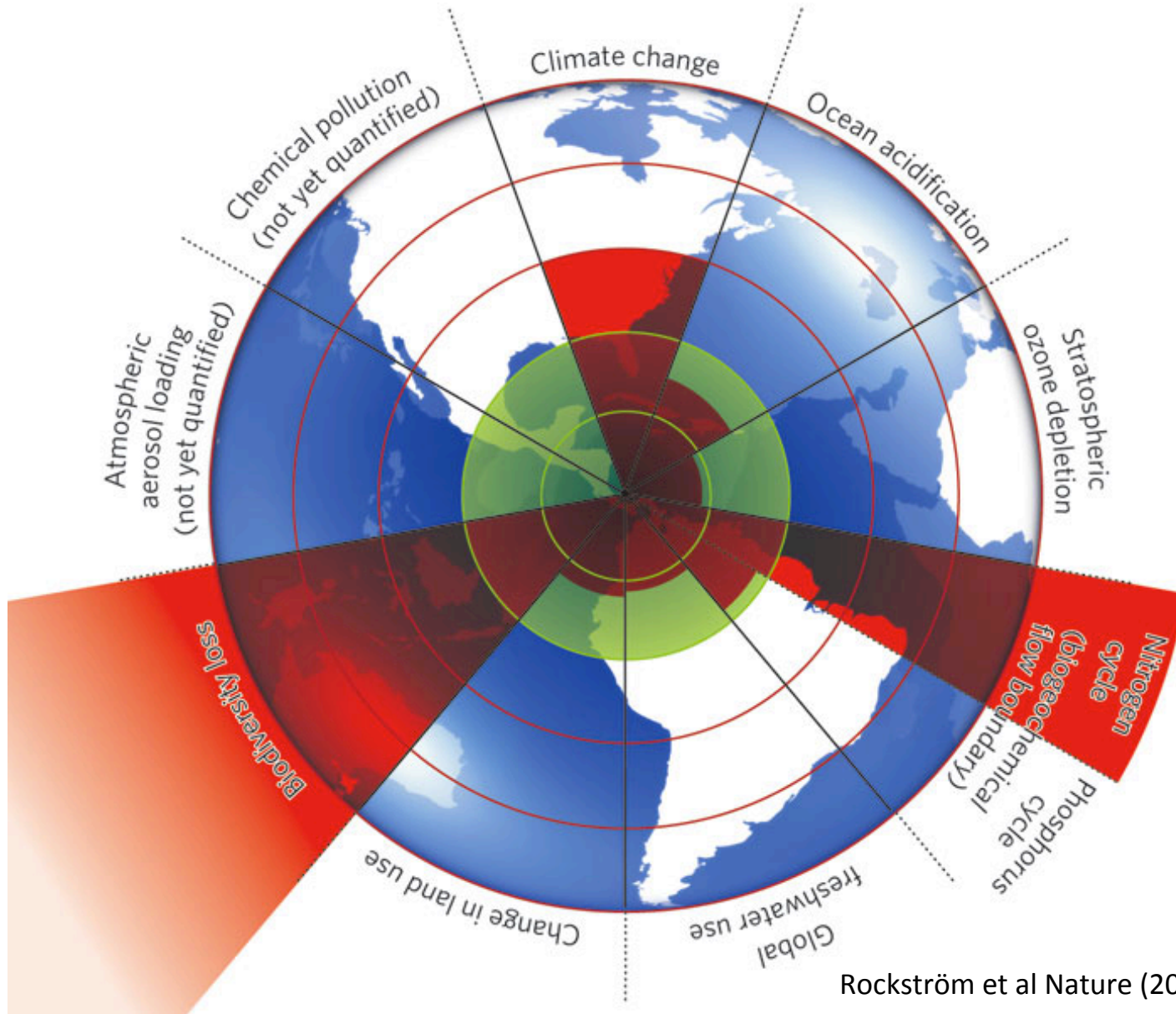

Rockström et al Nature (2009)

Population growth

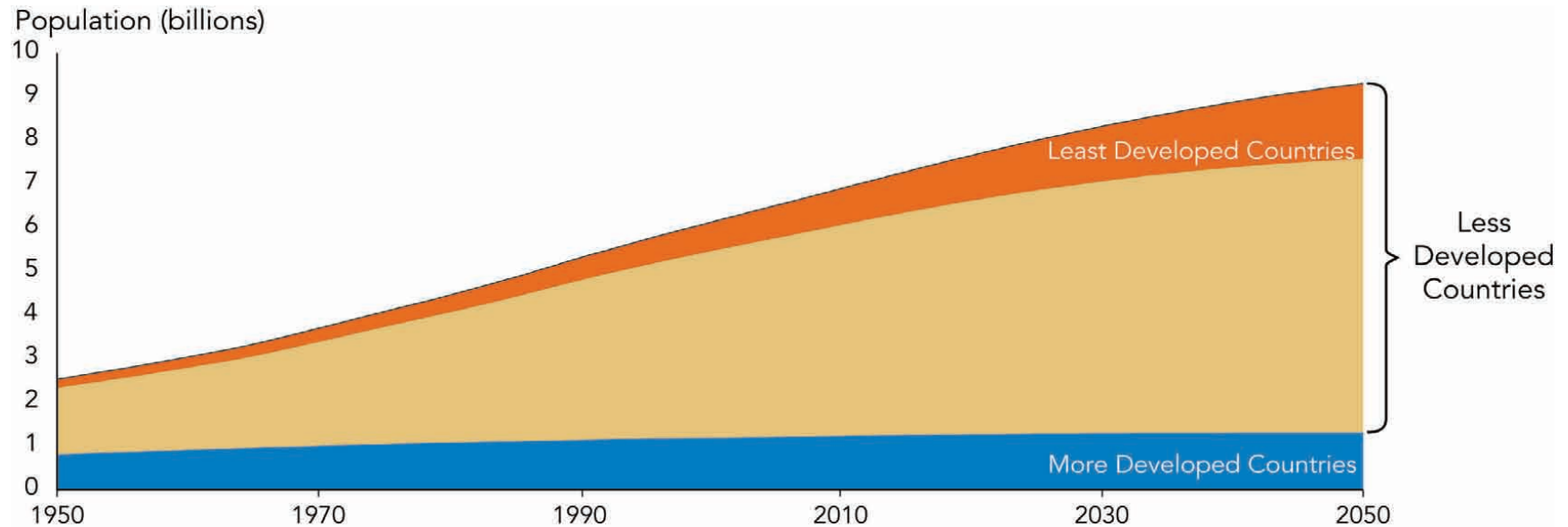

SOURCE: United Nations Population Division, *World Population Prospects: The 2010 Revision* (2011), medium variant.

~9 billion people by 2050, requires at a minimum 65-70% increase in cereal production (FAO 2012)

How to meet 2050 demand?

1. Increase crop area
2. Increase water use
3. Virtual water trade
4. Increase crop yield/efficiency

Climate Change

Atmospheric CO₂

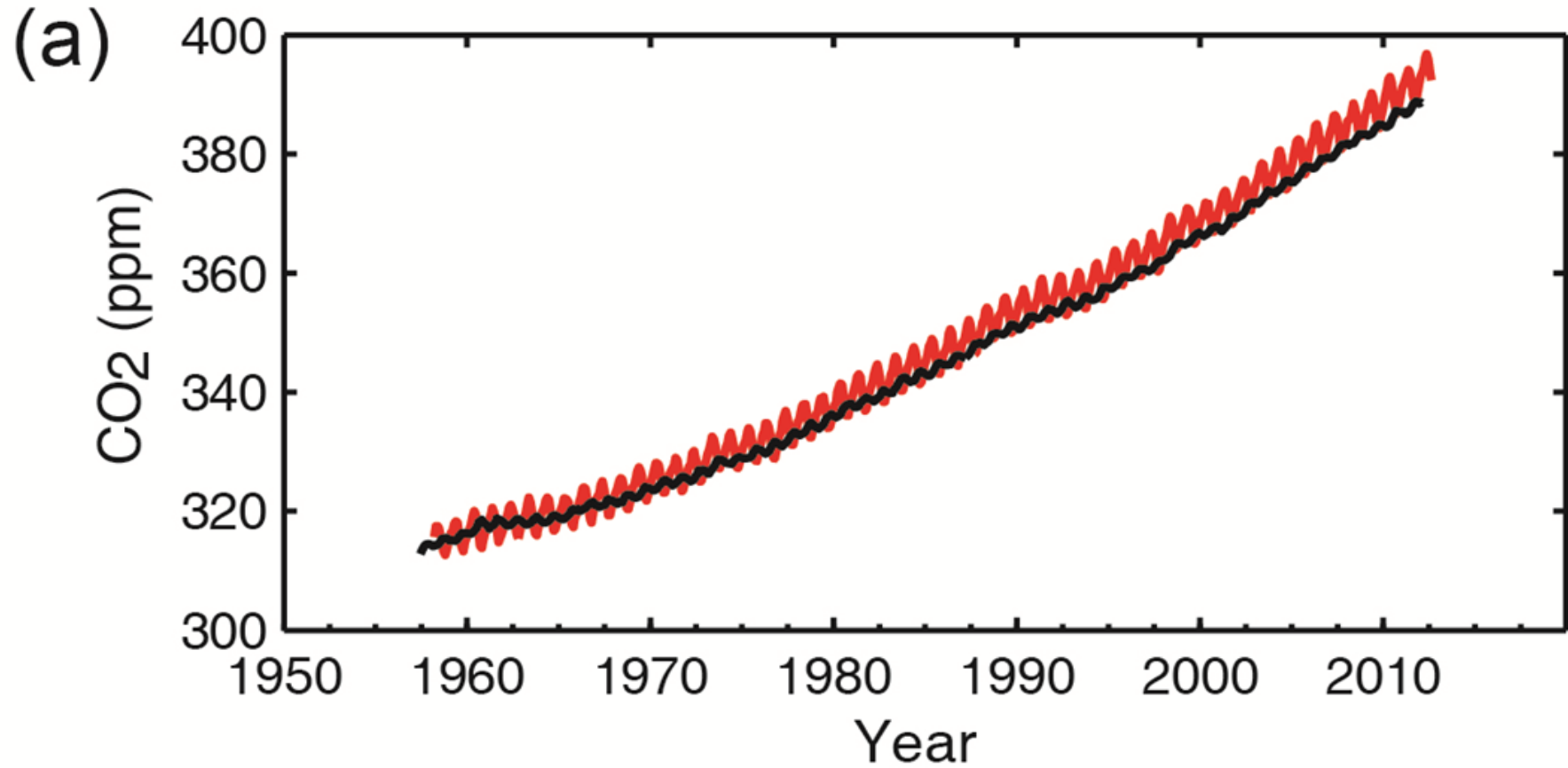

Simulations

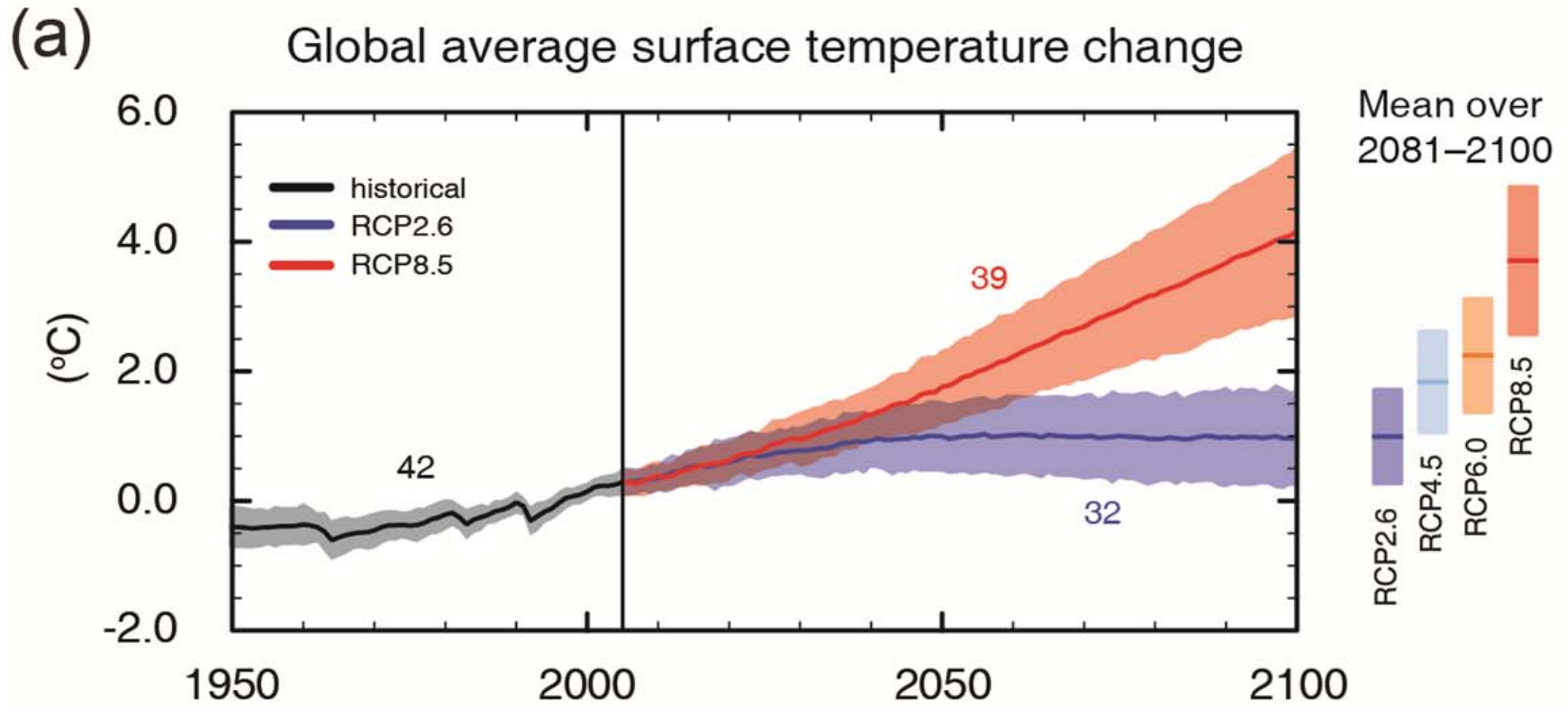

Projected Changes in the Hydrocycle

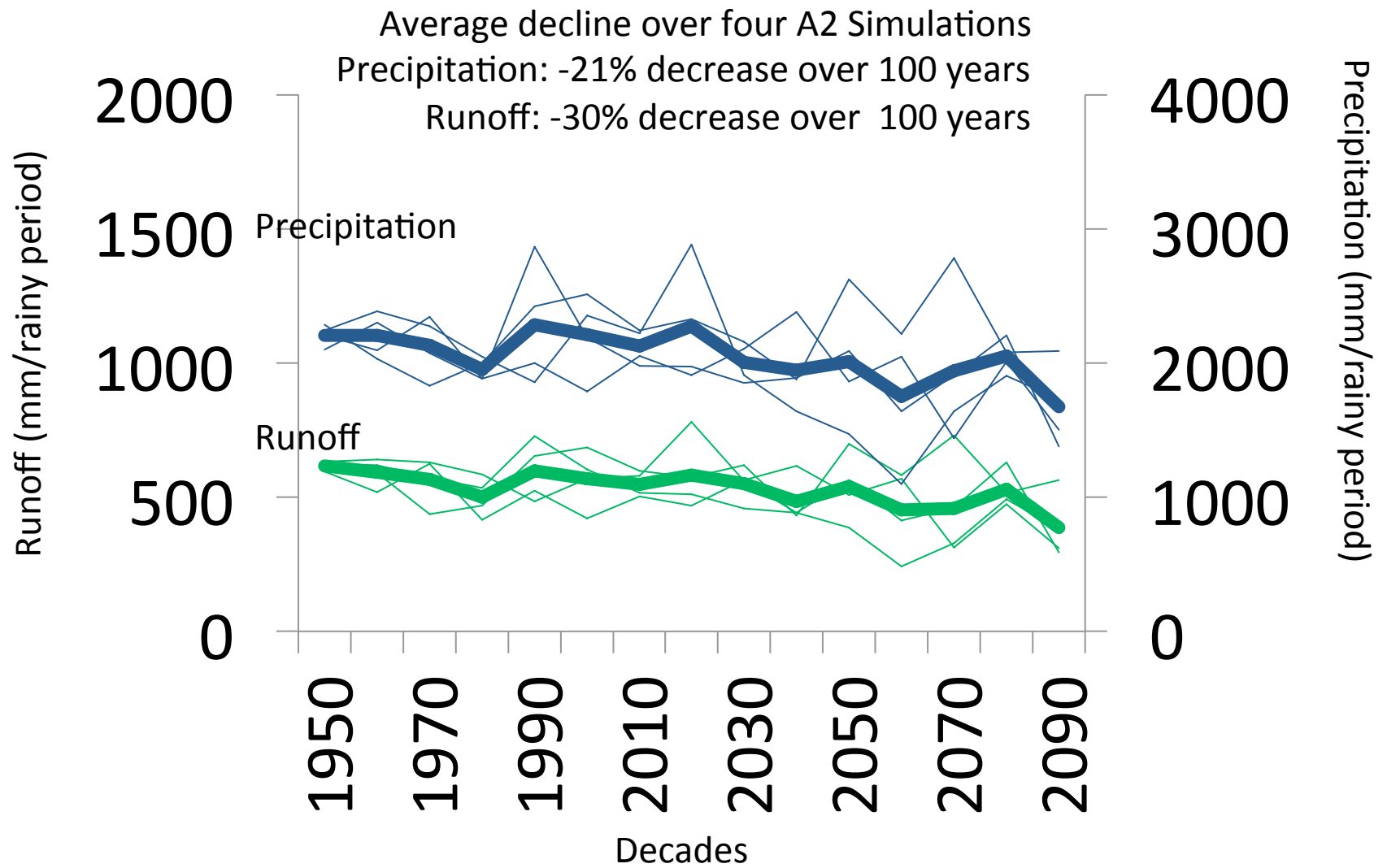

Extreme Events

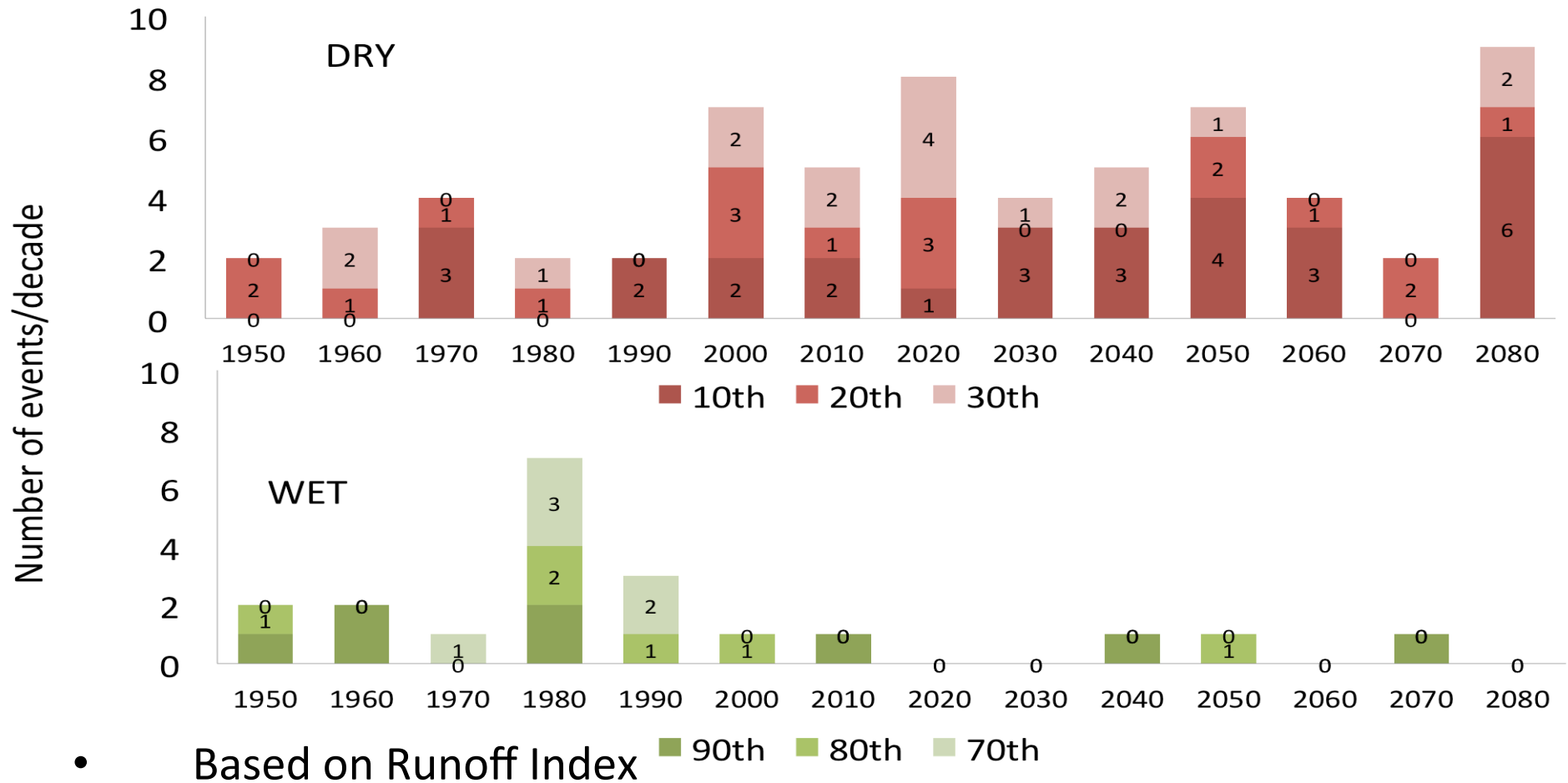

- Based on Runoff Index
- Gamma distribution (1960-1989)

Improve Predictability

Previous

ICs

Forecast

Prediction

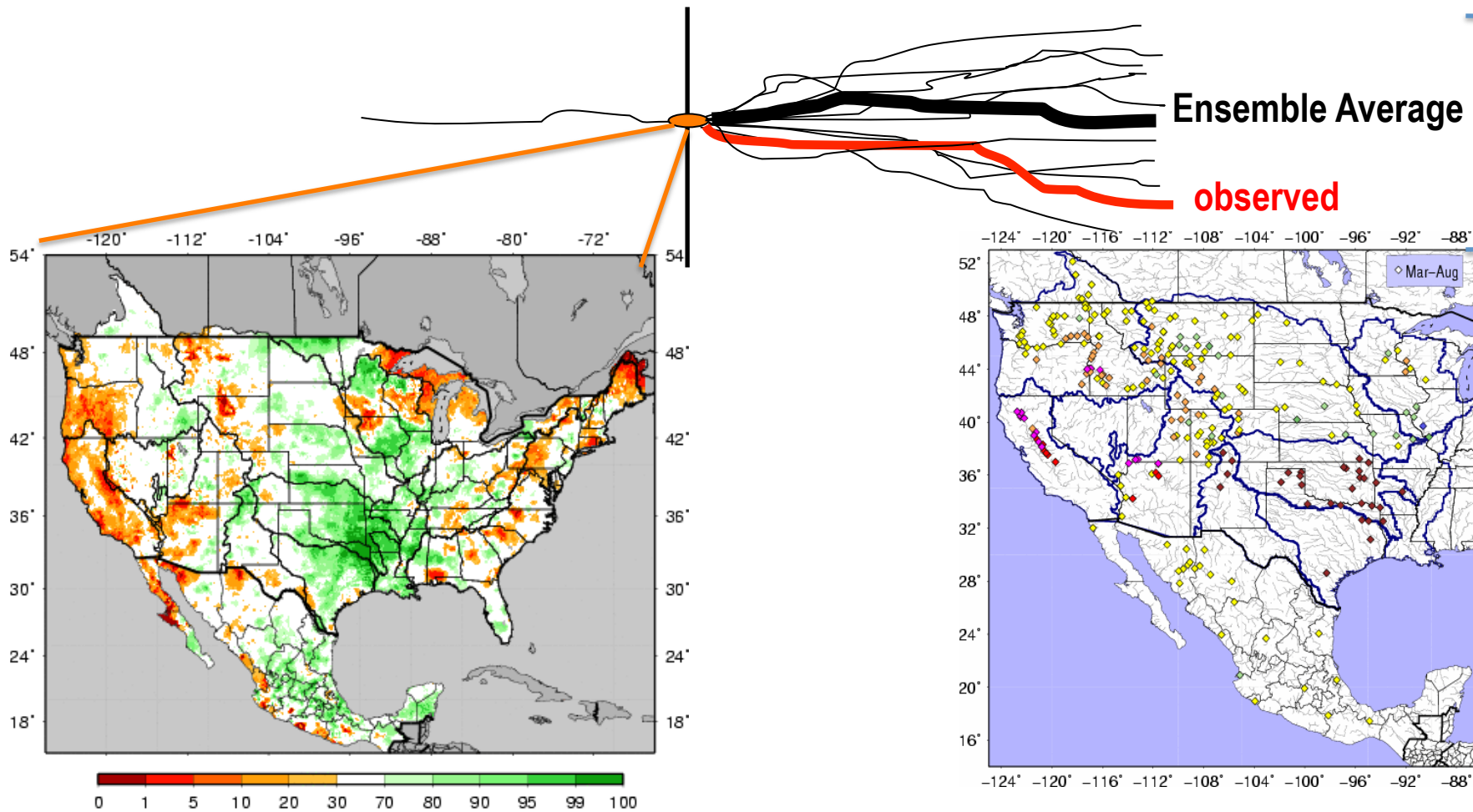

Observations and models

Numerical and Statistical Modeling

Extensive Field Measurements

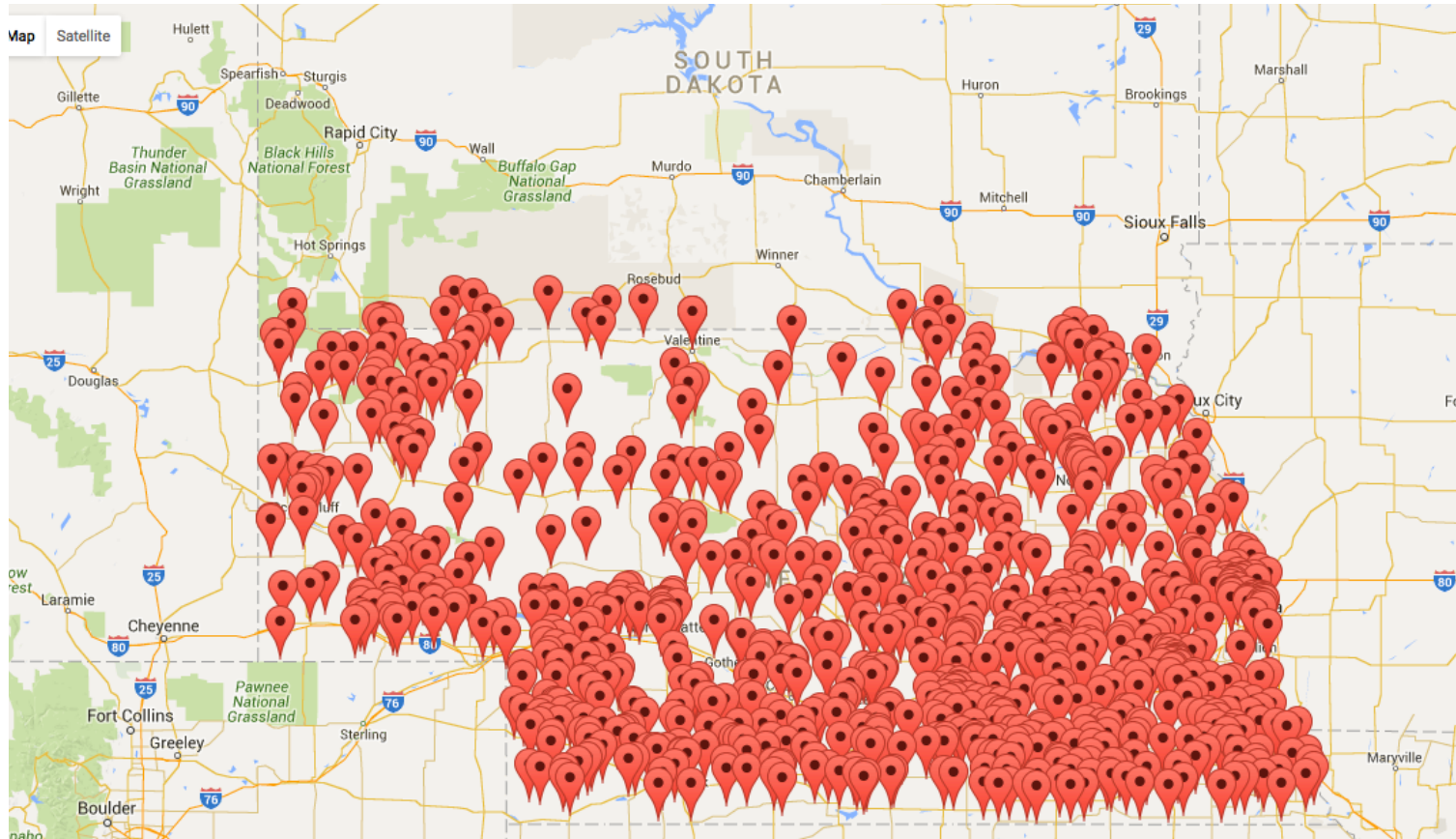

<http://www.hprcc.unl.edu>

Improve Monitoring Networks (or Initial Conditions)



Spatial Distribution

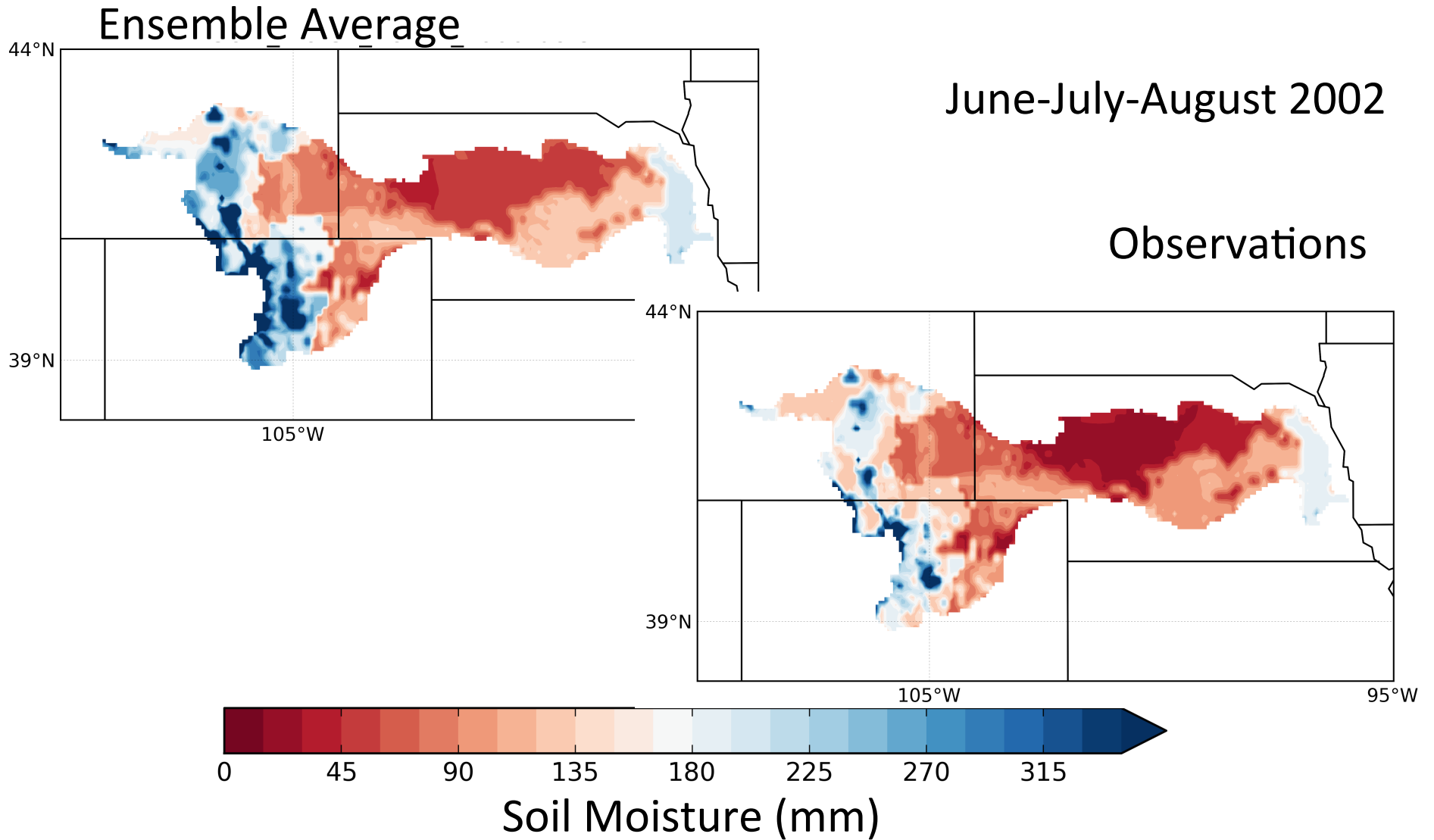

Contrasting Hydrometeorological Extremes

May-June-July-August

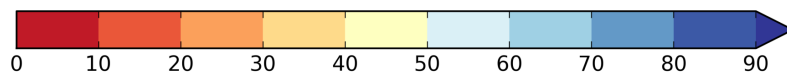
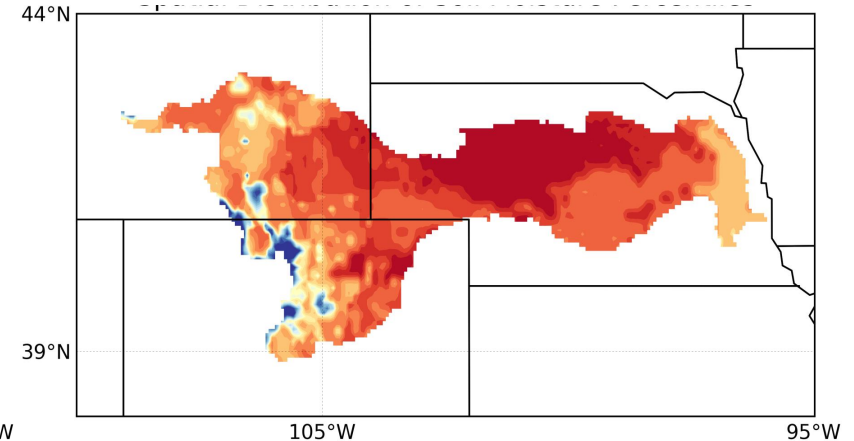
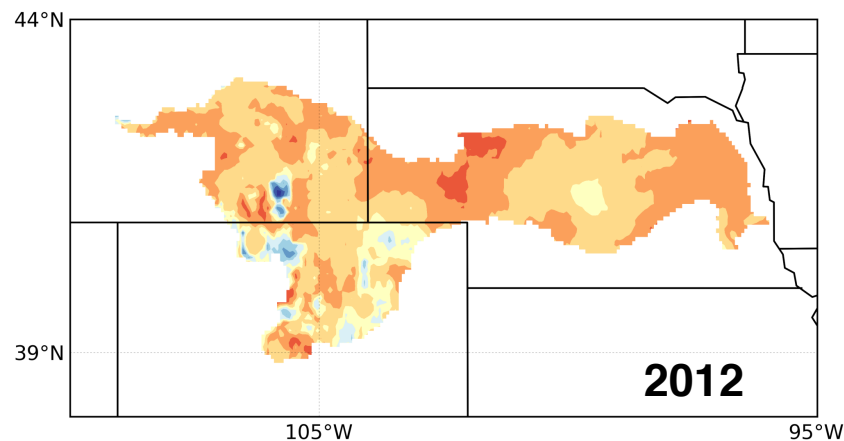
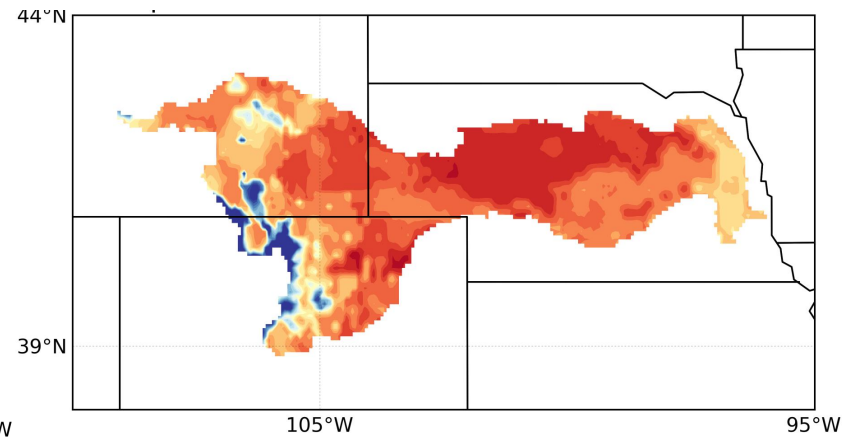
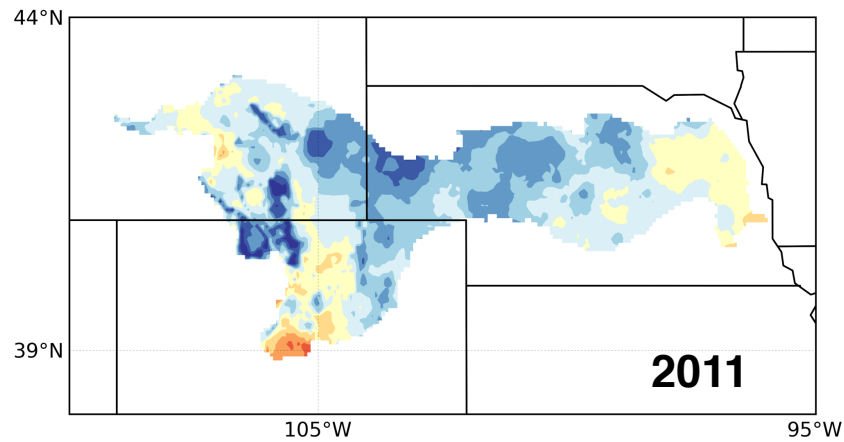

Soil Moisture Percentiles

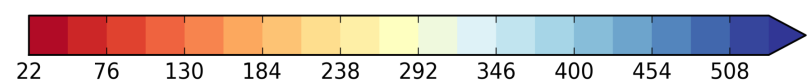

Soil Moisture

Statistical Techniques

Likelihood of Precipitation Maxima

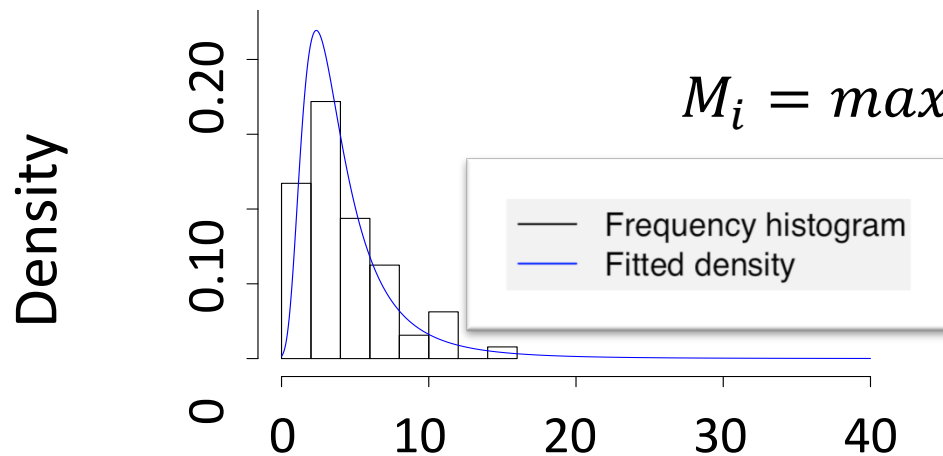
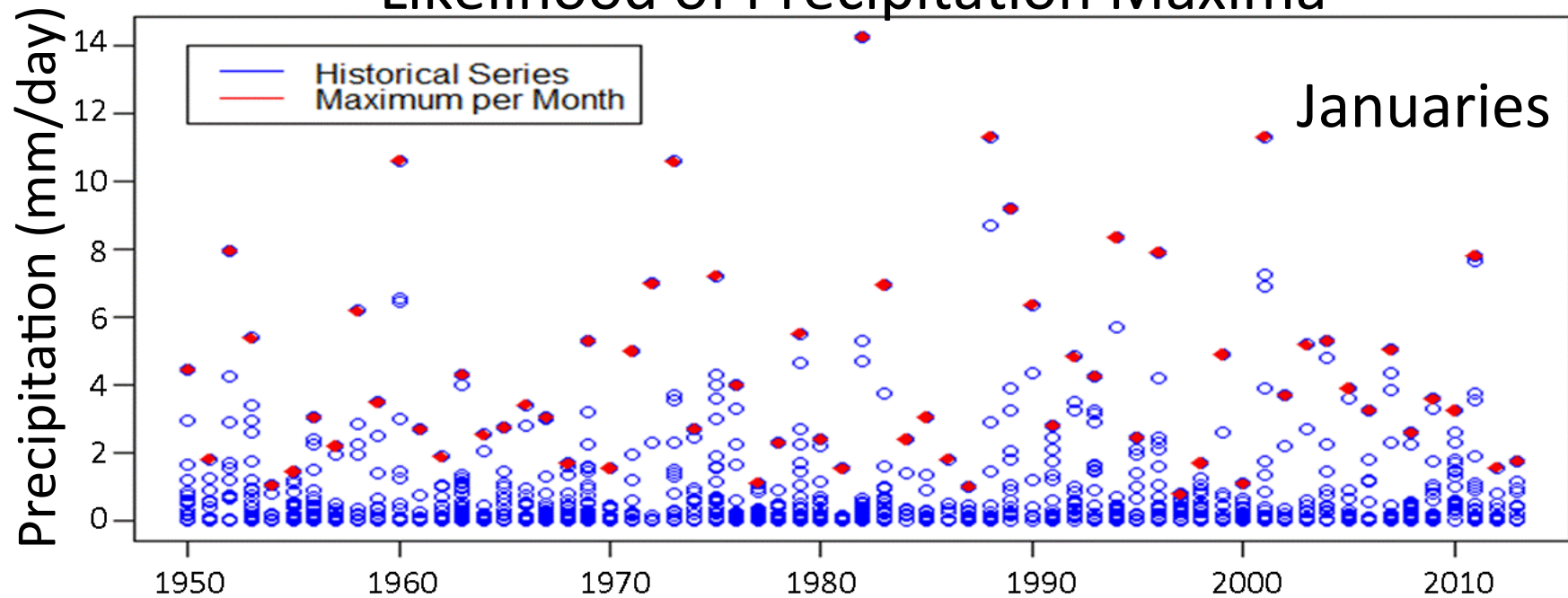

$$M_i = \max(X_1^{(i)}, \dots, X_s^{(i)}), i = 1, \dots, 64$$

Maximum Precipitation Return Periods

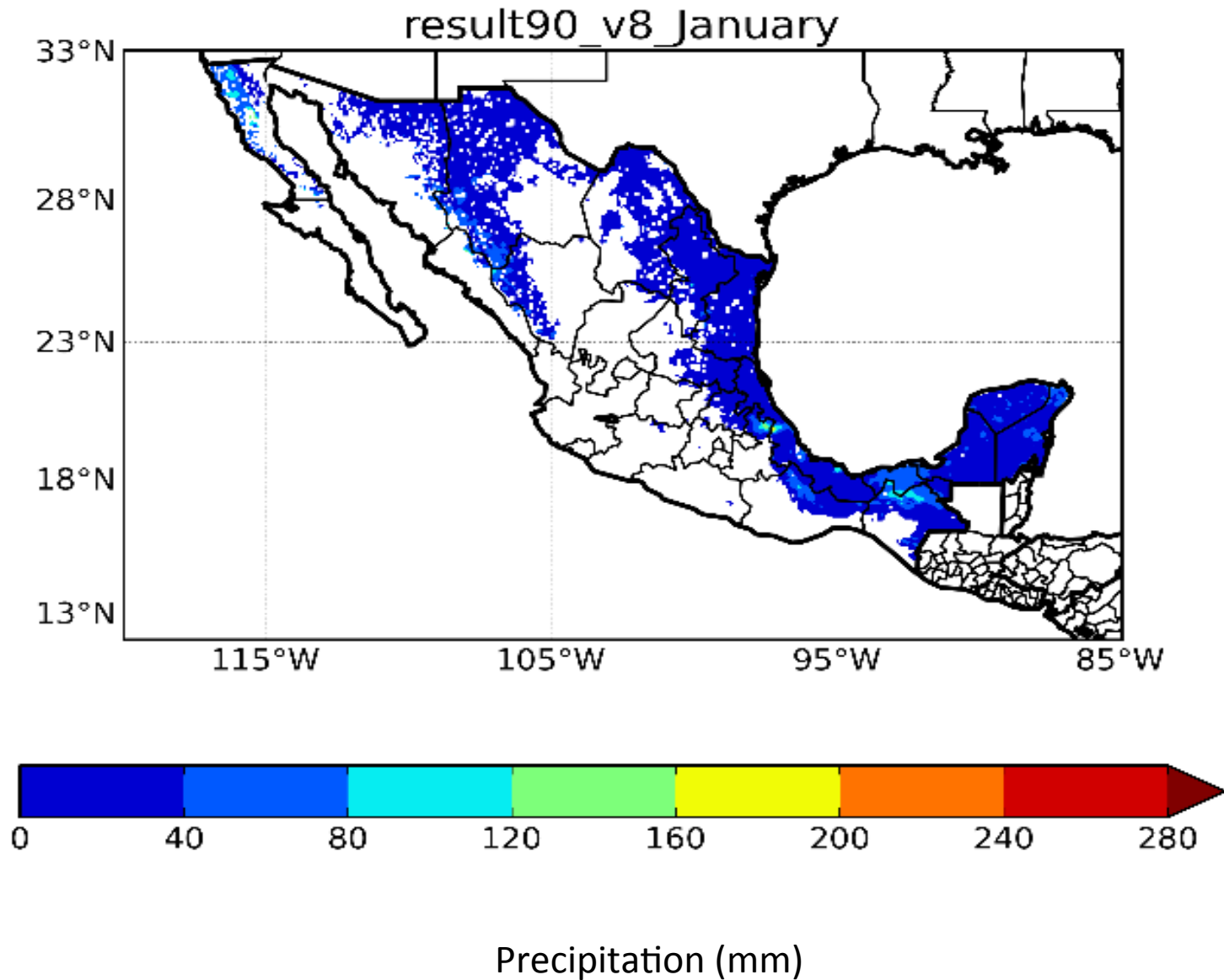

Improve Modeling

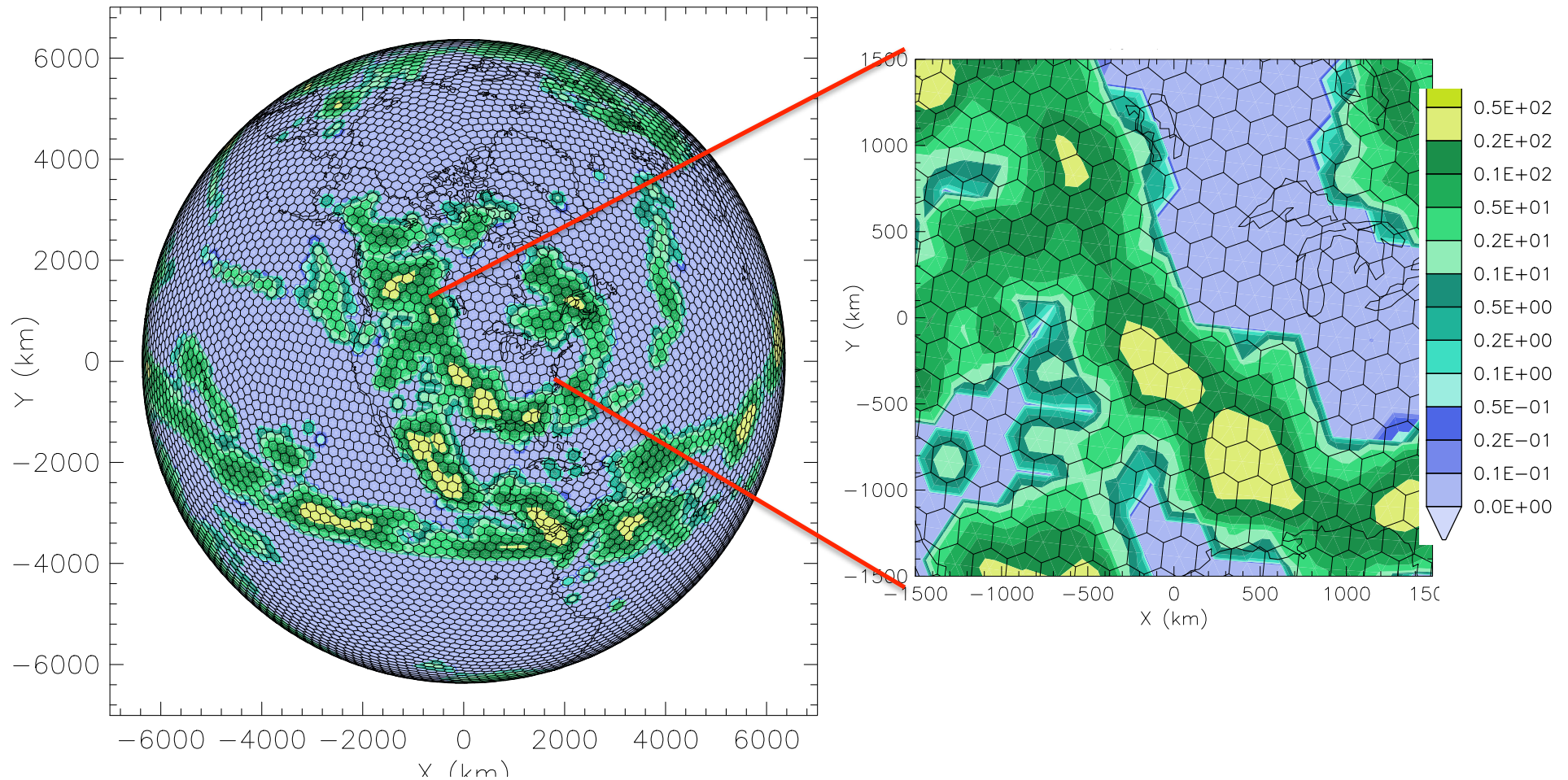

- Multi-scale meteorologic and climate model non-hydrostatic

Short-term forecast

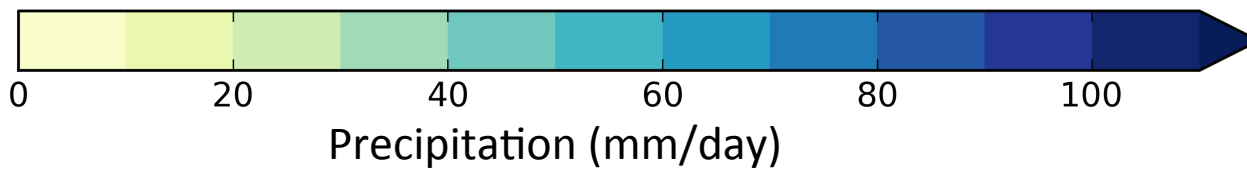
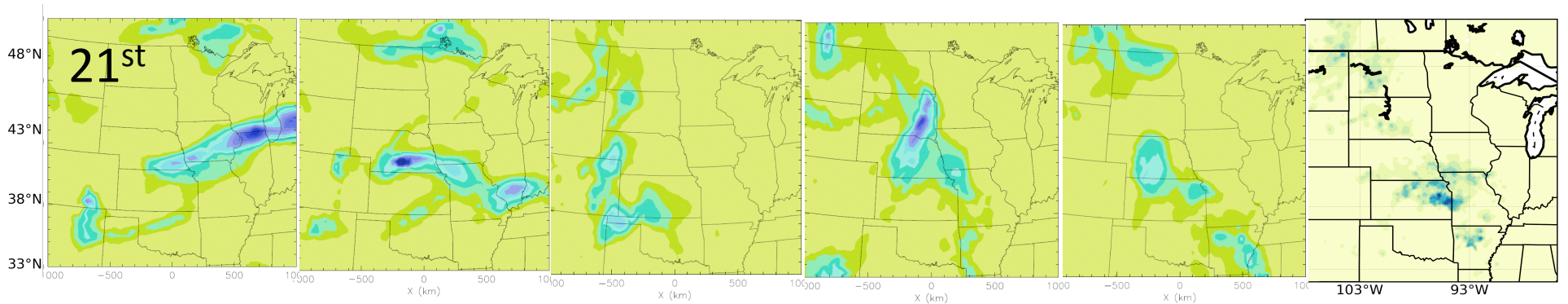
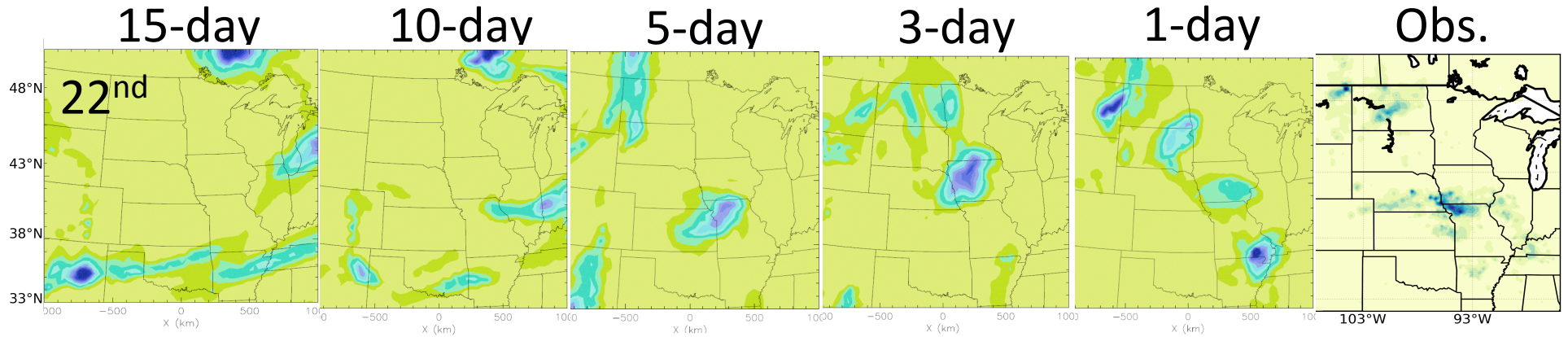
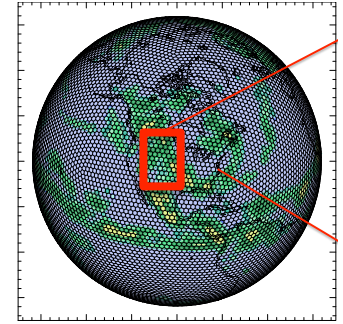

Seasonal forecast

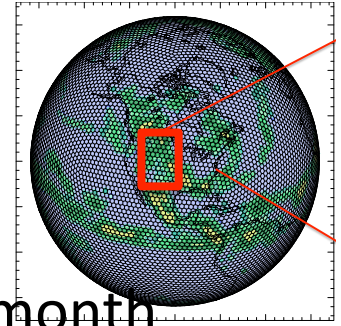

ICs

Lead-time

1-month

4-month

7-month

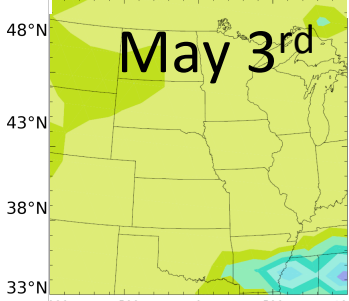
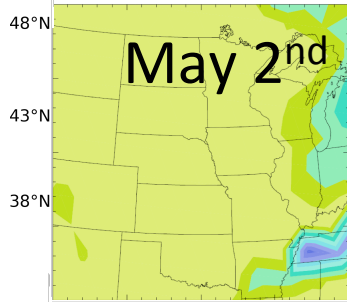
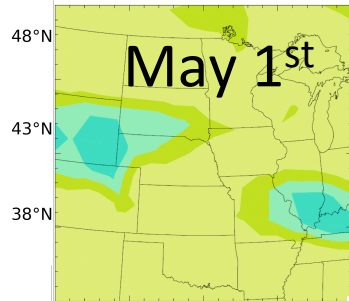

Obs.
June

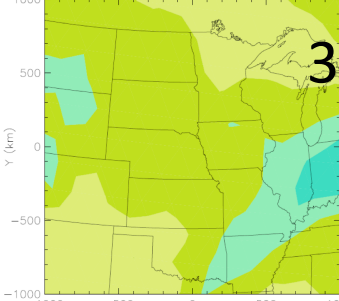
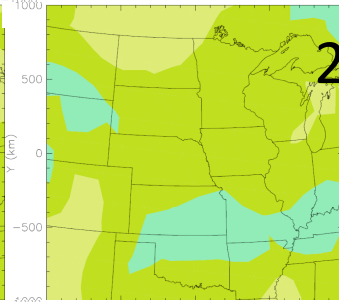
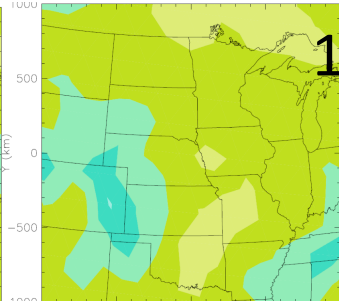
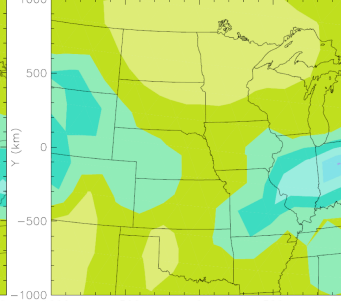
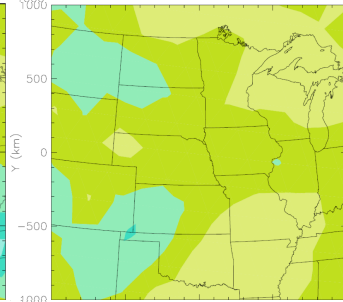
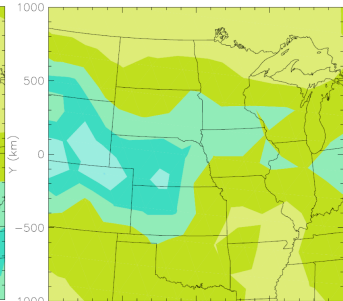
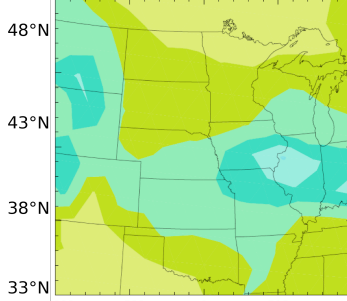
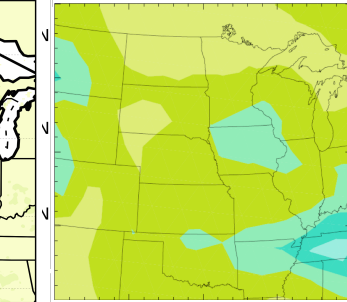
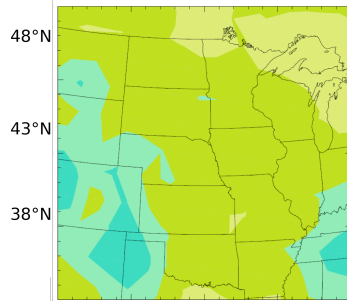
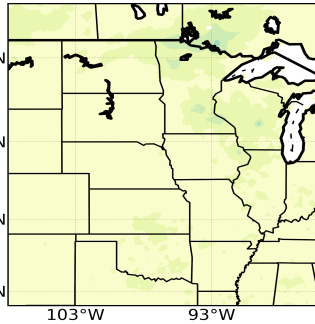

1st day

2nd day

3rd day

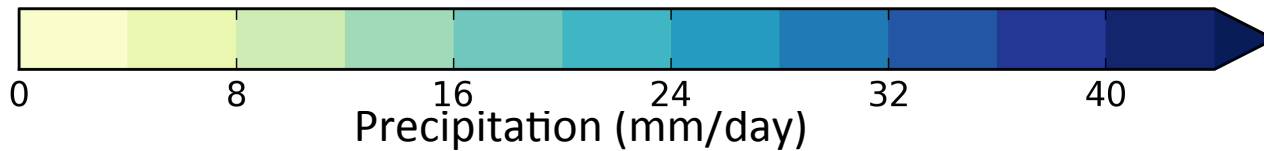

Socioeconomic and Technologic Aspects

Net Farm Income

\$1'900 Billion
(2001)

\$7'300 Billion
(2011)
(a)

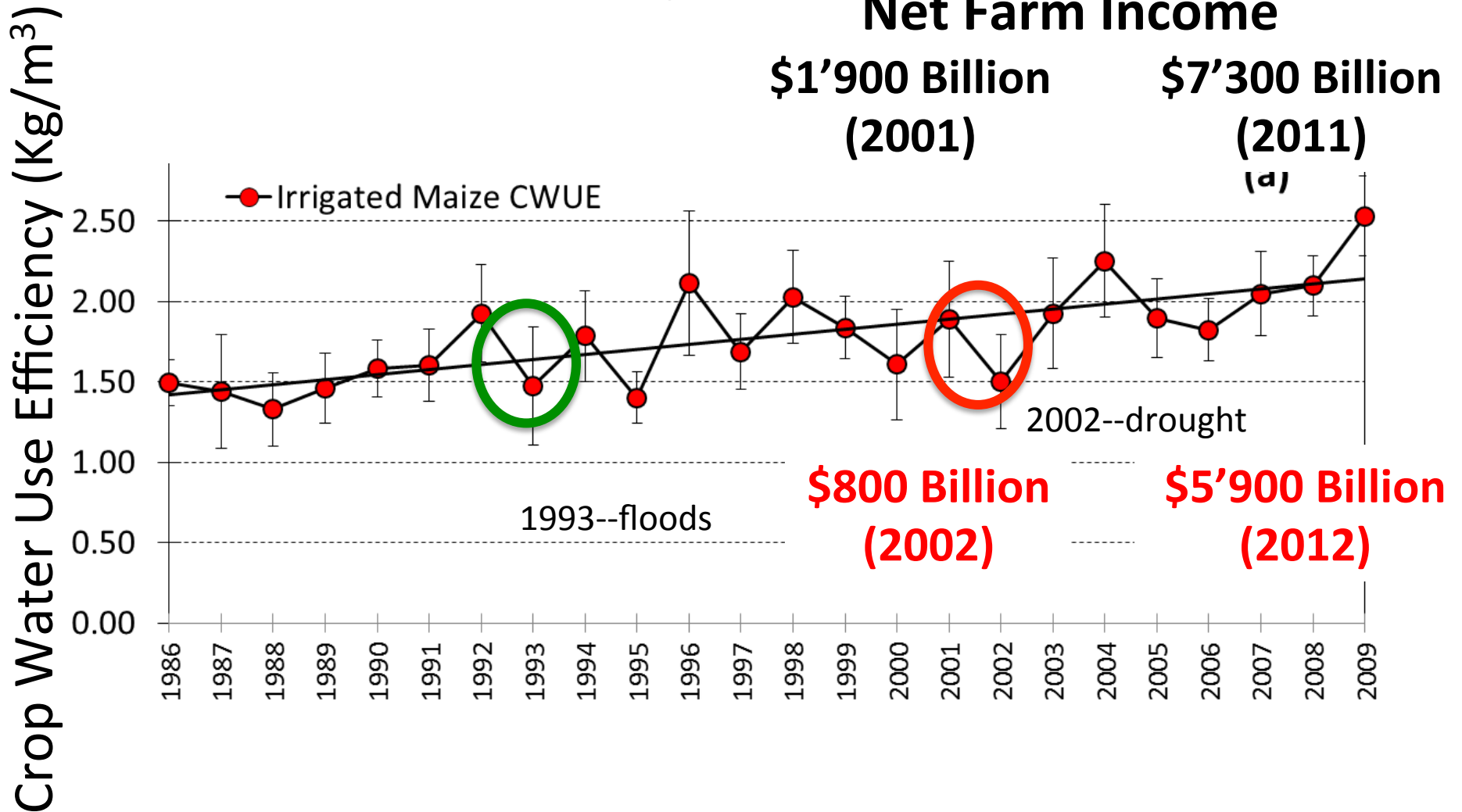

Global Water System

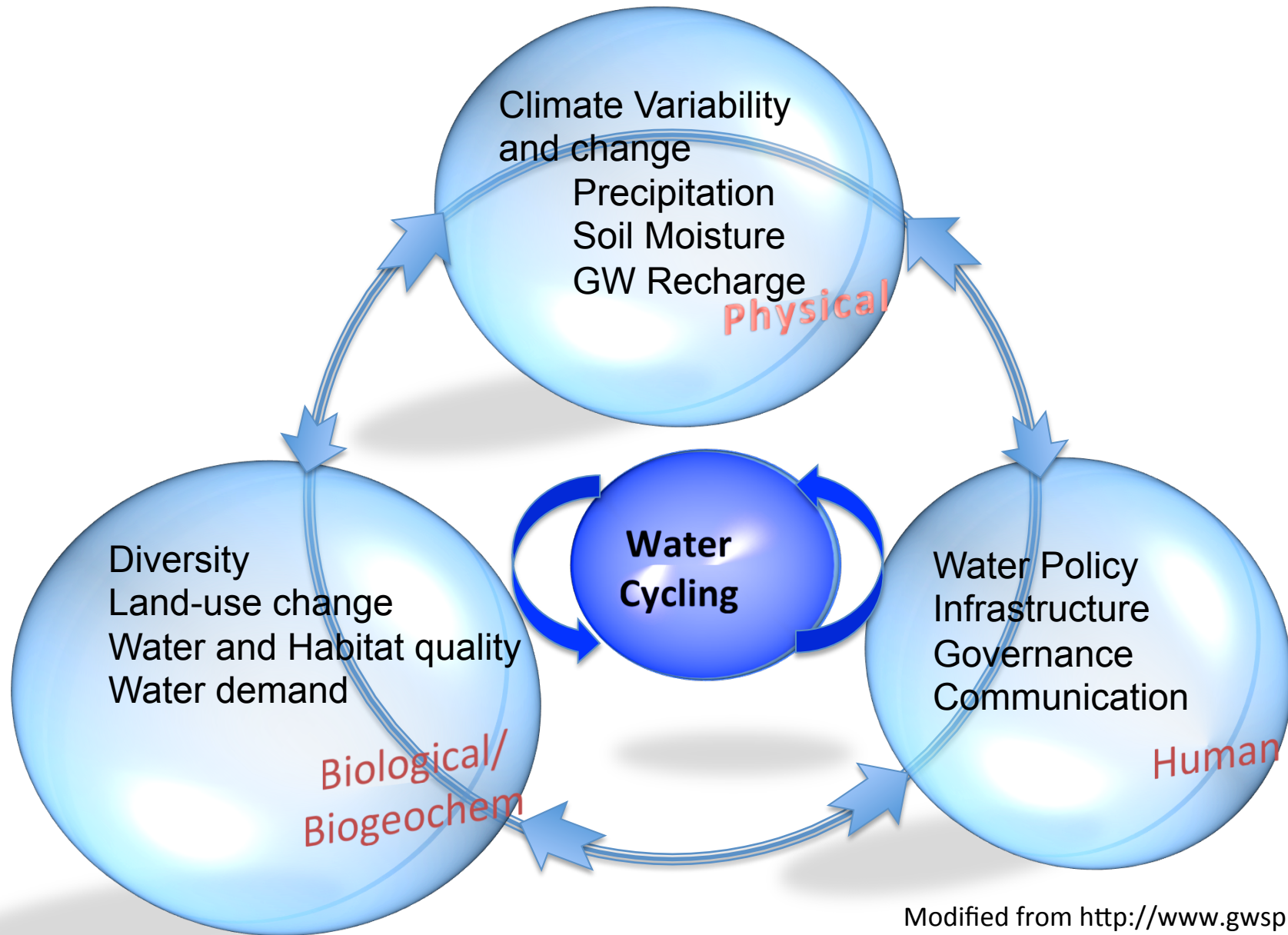

Modified from <http://www.gwsp.org/>

Integrative Mechanisms

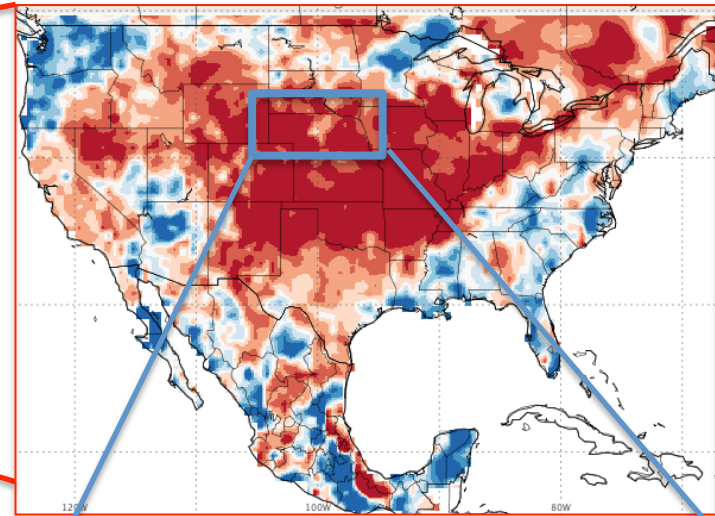
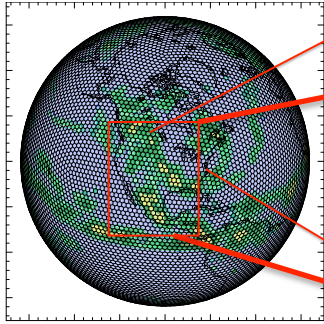

Standardized Soil Moisture Anomaly

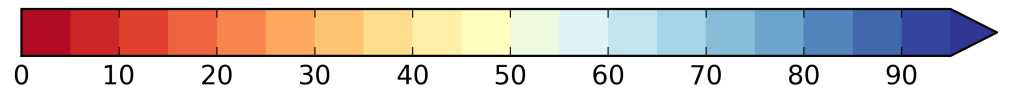
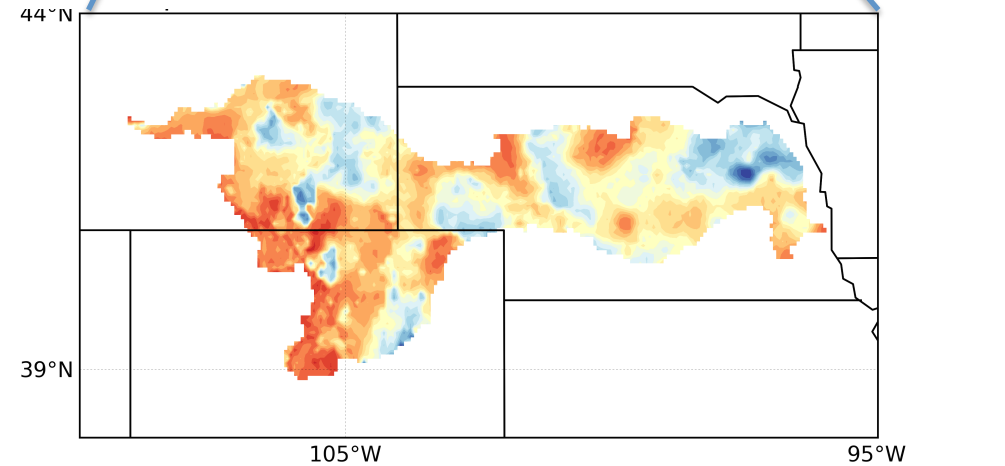
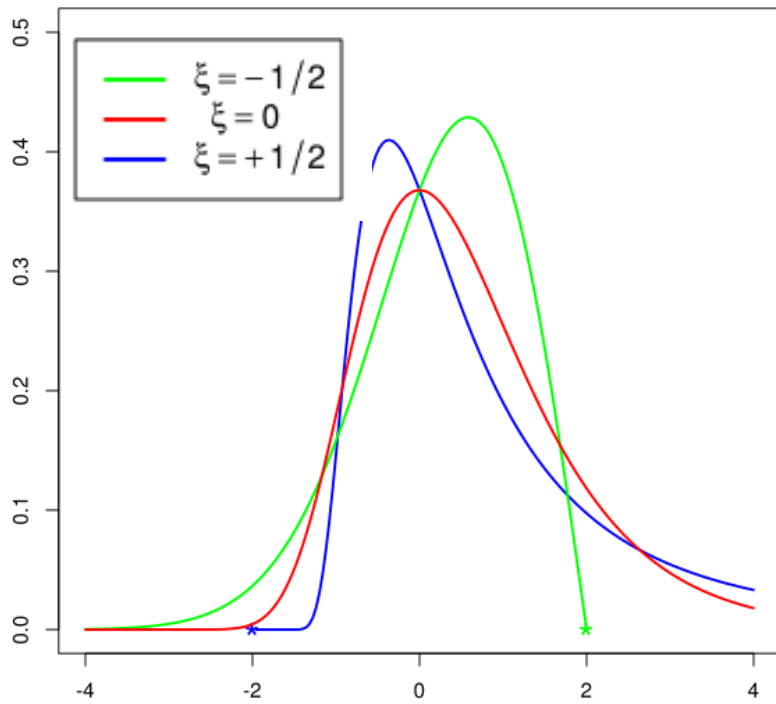
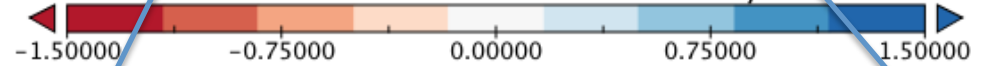

Soil Moisture Percentiles

The Challenge: Scales



The Water Cycle

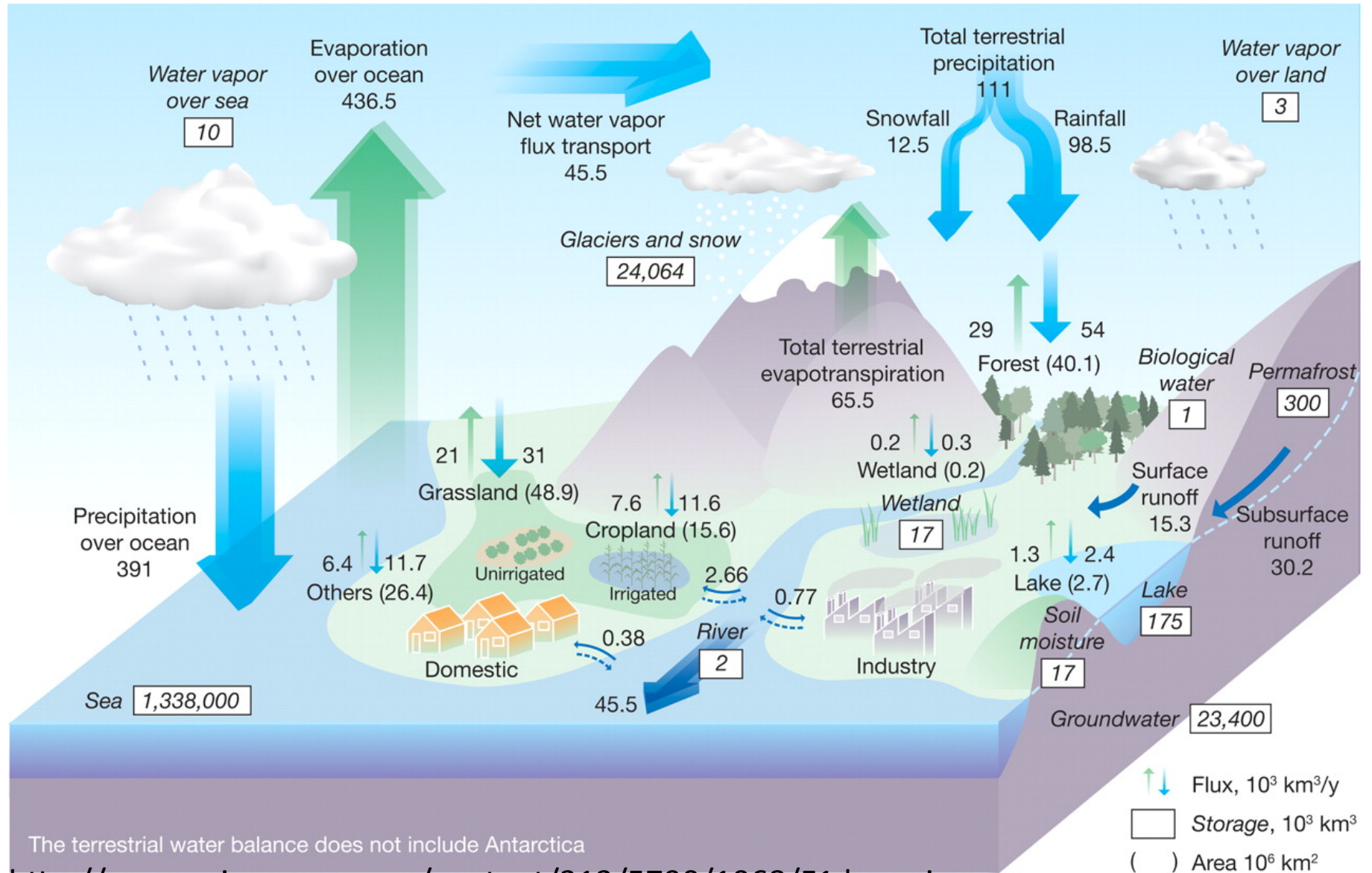

The terrestrial water balance does not include Antarctica

<http://www.sciencemag.org/content/313/5790/1068/F1.large.jpg>

Watershed

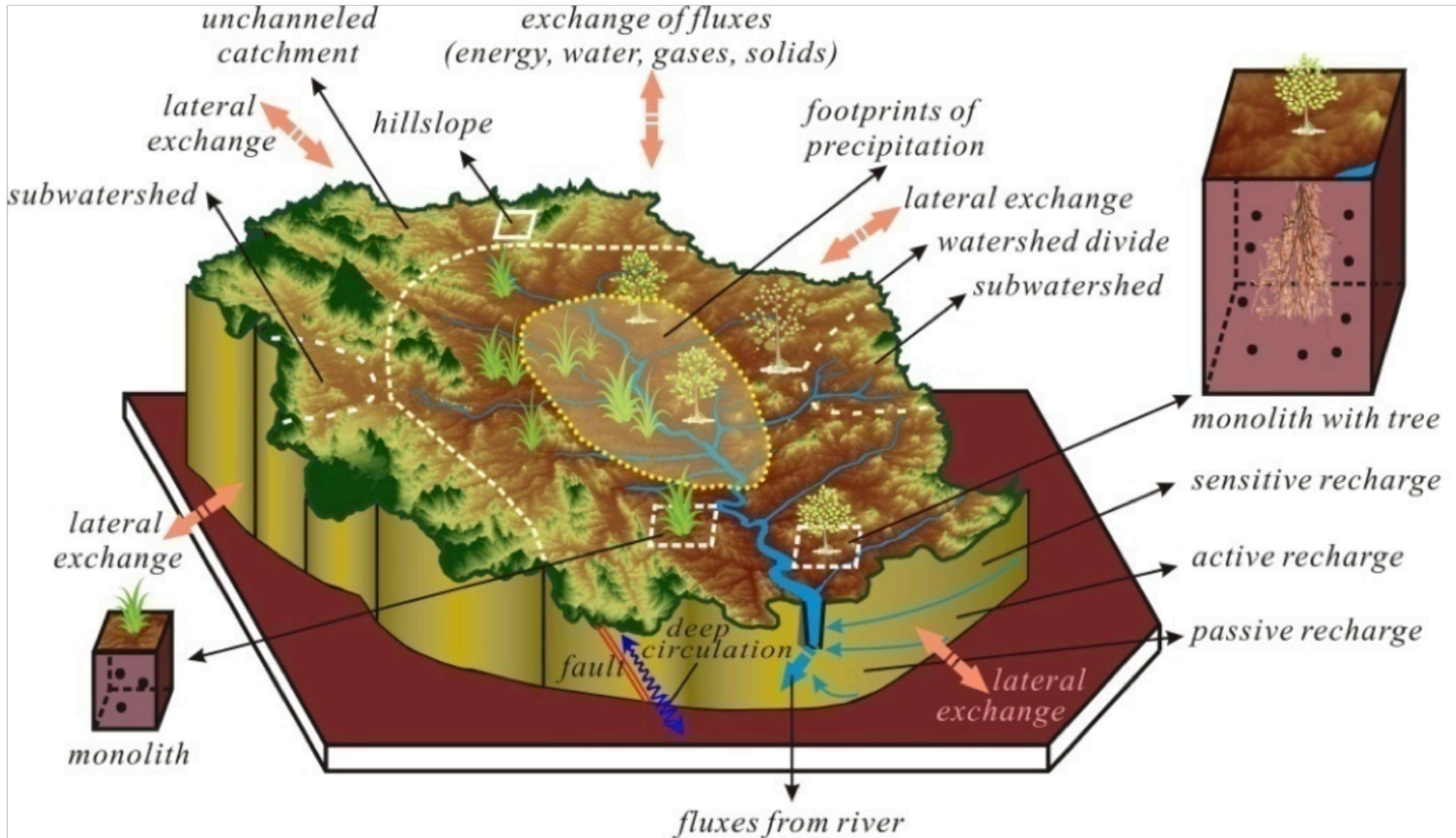

Watersheds as a relative elementary volume (**REV**)

The Water Cycle at the Canopy Scale

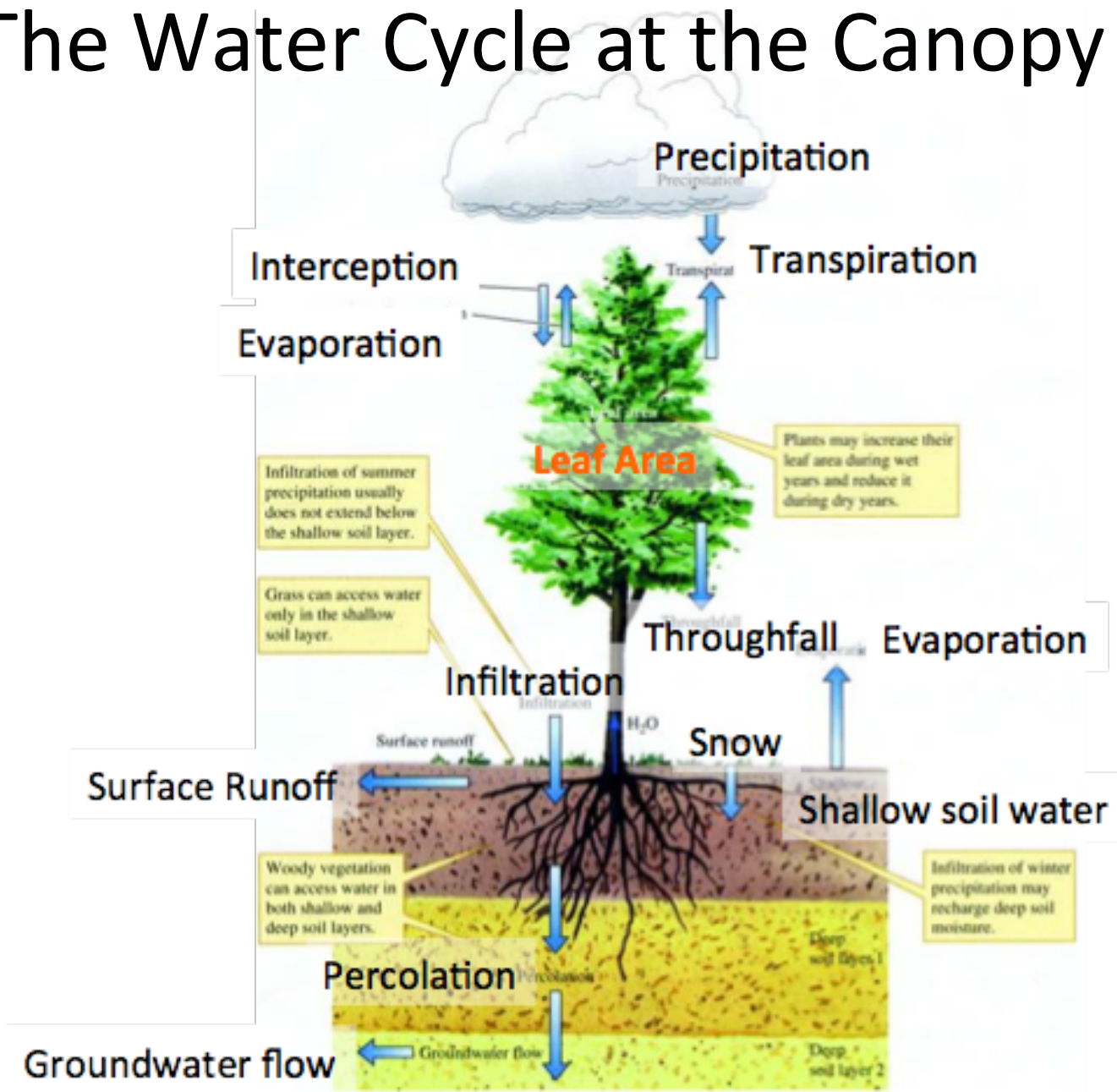

Processes, phenomena, and Scales

1) Human environments, floods

2) Droughts

3) Climate Change

4) Water supply, landscape productivity

5) Agricultural productivity

6) Transport

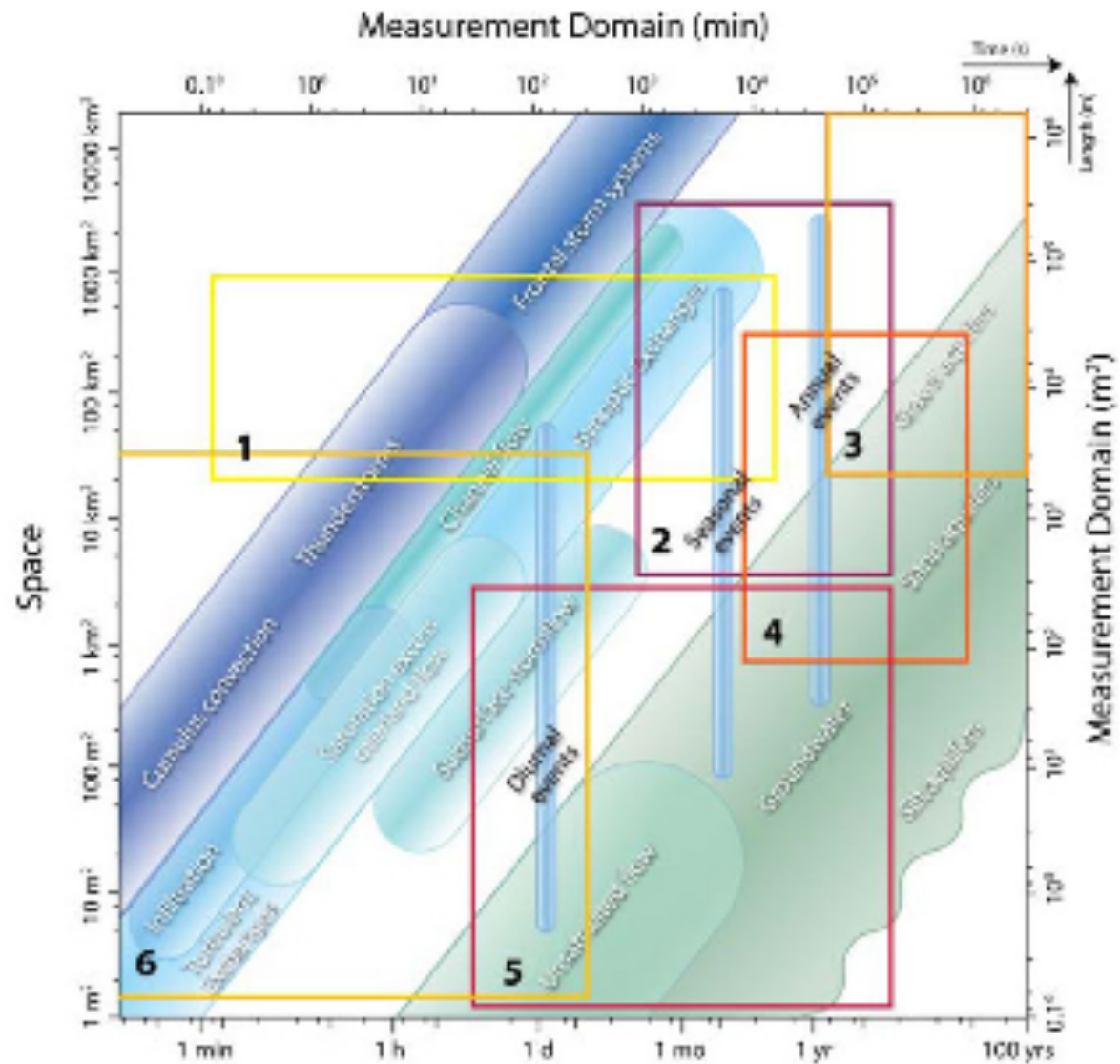

Water Balance

Consider a representative elementary volume (REV) of some kind (soil, lake, etc)

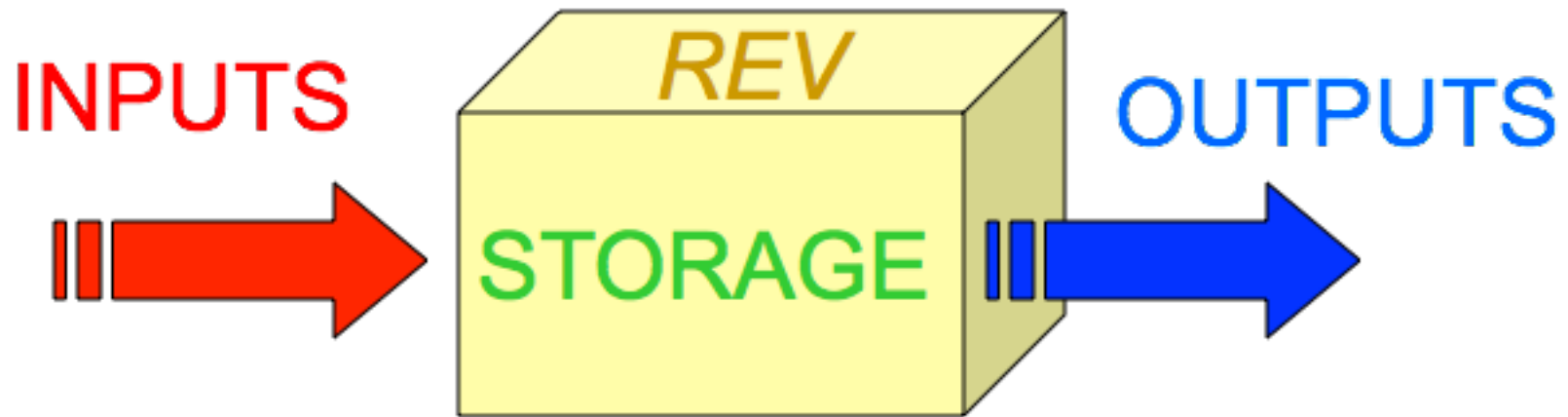

Inputs = Outputs \pm Change in Storage

$$I = O \pm \Delta S$$

Water Balance Parameters

INPUTS (I)

- Precipitation
 - Rain
 - Snow/Ice
 - Fog/Mist
- Surface Water
 - Runoff (overland flow)
 - Soil Water (interflow)
- Groundwater

OUTPUTS (O)

- Evaporation
 - Open Water
 - Bare Soil
 - Leaf/Plant Surfaces
- Transpiration
- Surface Water
 - Runoff (overland flow)
 - Soil Water (interflow)
- Groundwater

Water Balance Parameters

STORAGE (ΔS)

- Atmosphere / Clouds
- Lakes / Rivers / Reservoirs
- Glaciers
- Canopy / Biomass
- Soil Moisture
- Aquifers (Groundwater)
- Ocean
- Snow Pack



Water Balance Equation

$$P + SW_{in} + GW_{in} = E + T + SW_{out} + GW_{out} + \Delta S$$

$$P + SW_{in} + GW_{in} = ET + SW_{out} + GW_{out} + \Delta S$$

P = Precipitation

SW = Surface Water

GW = Ground water

E = Evaporation

T = Transpiration

ET = Evapotranspiration

ΔS = Water Storage

Hydrologic Conditions

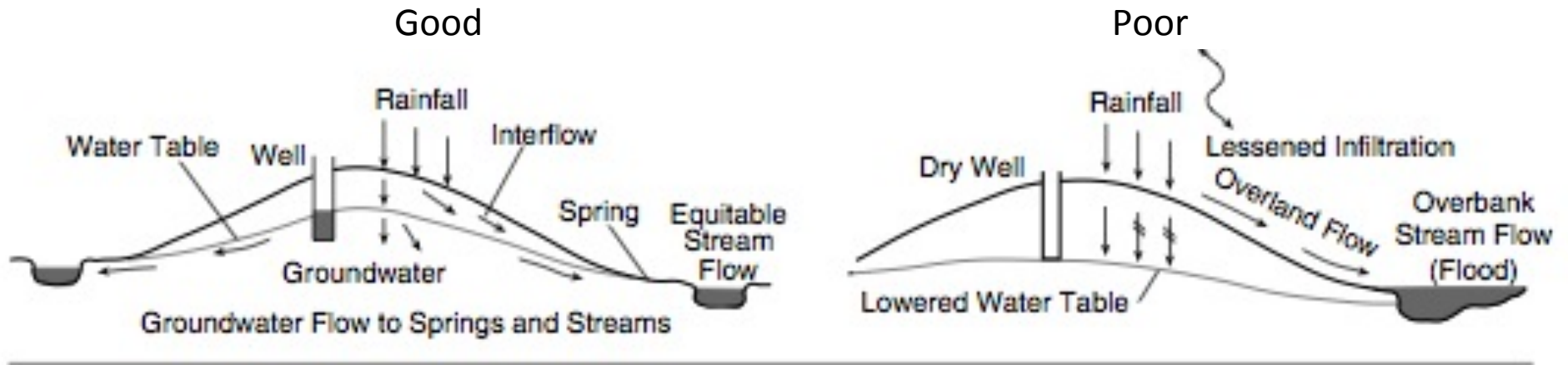

Infiltration is key in maintaining good hydrologic conditions

Infiltration decreases

- Generating overland flow
- Increasing Erosion
- Increasing flooding
- Base flow decreases
 - reduced interflow and GW

Infiltration, Land-use and Time

Proportion of Rainfall Infiltrating

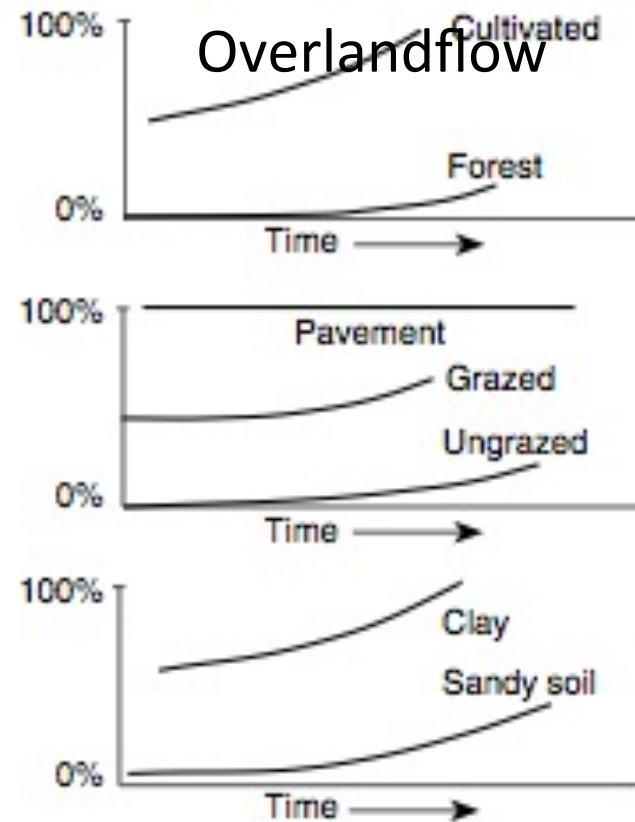
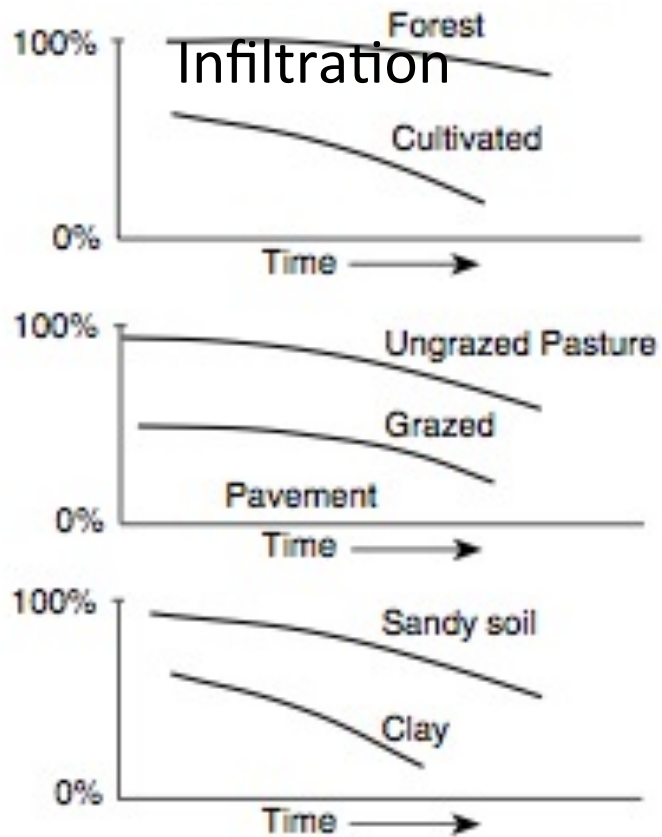

Overland flow = Precipitation - Infiltration

Flooding and Land-use

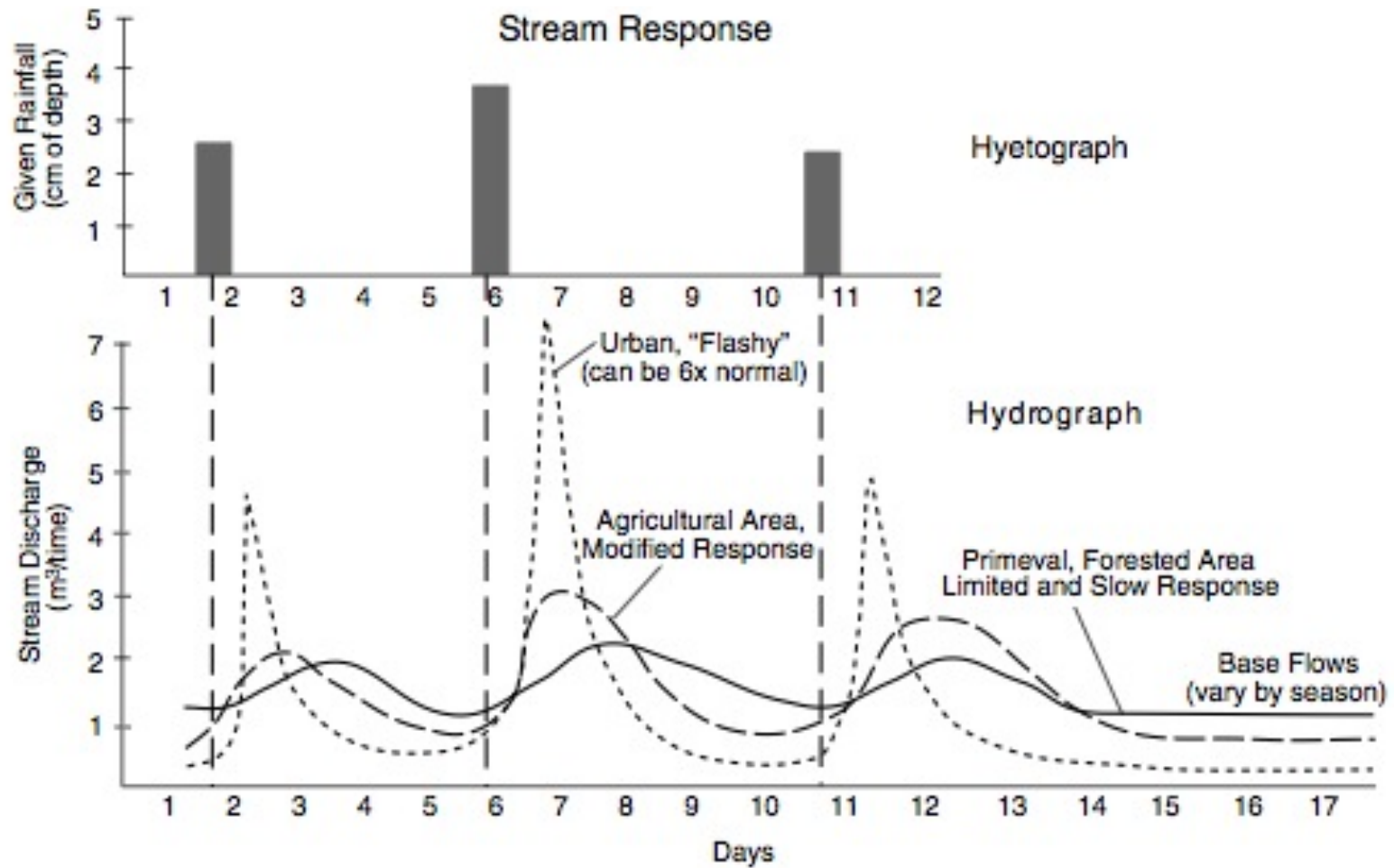

Agro-ecosystem and Ecosystem's Responses



June 1st 2004

June 7th 2004

Southwestern North America (Rayon, Mexico)

North American Monsoon Experiment (NAME) and the Soil Moisture Experiment (SMEX2004)

Greening and Dormancy

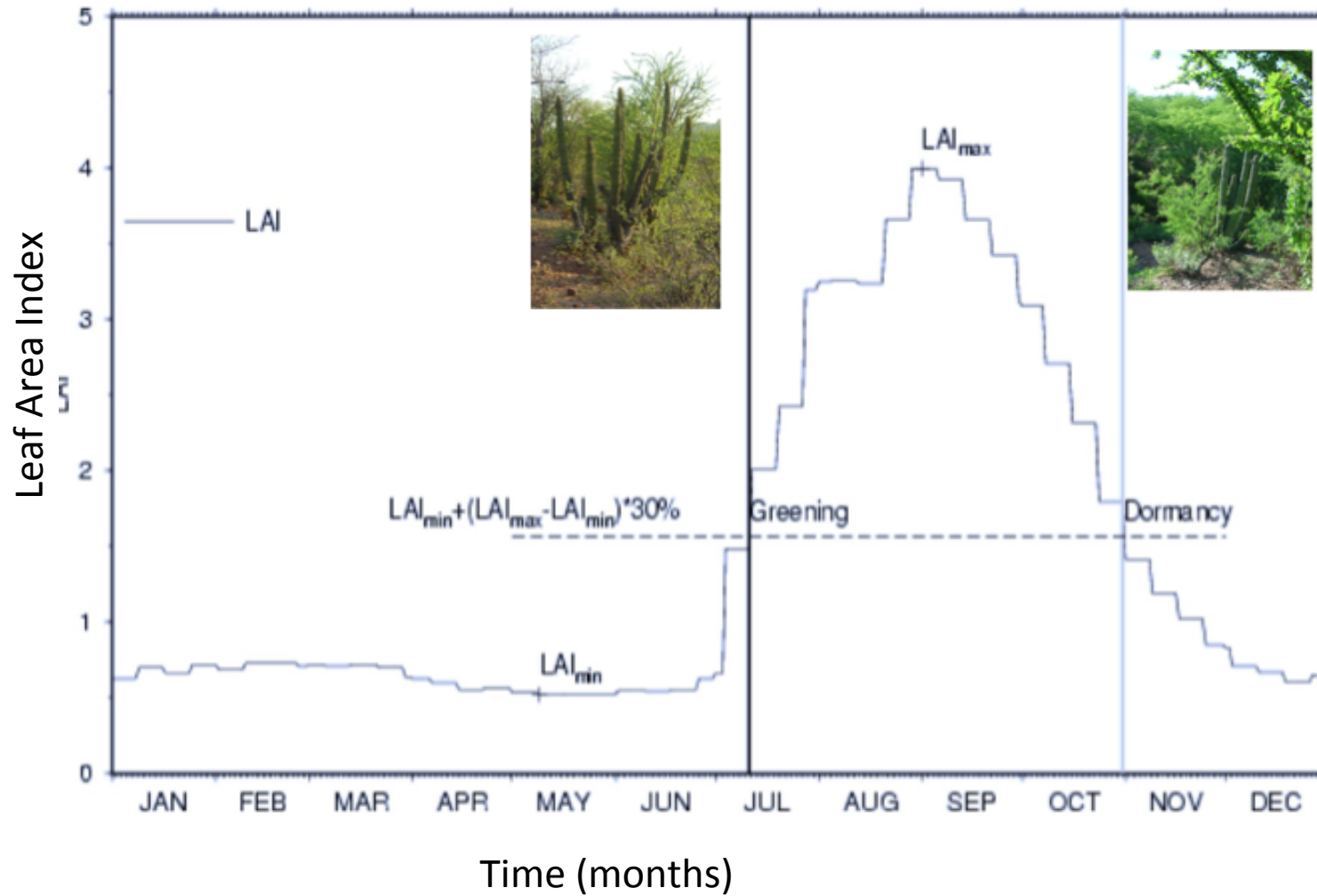

Regional Scale Greening

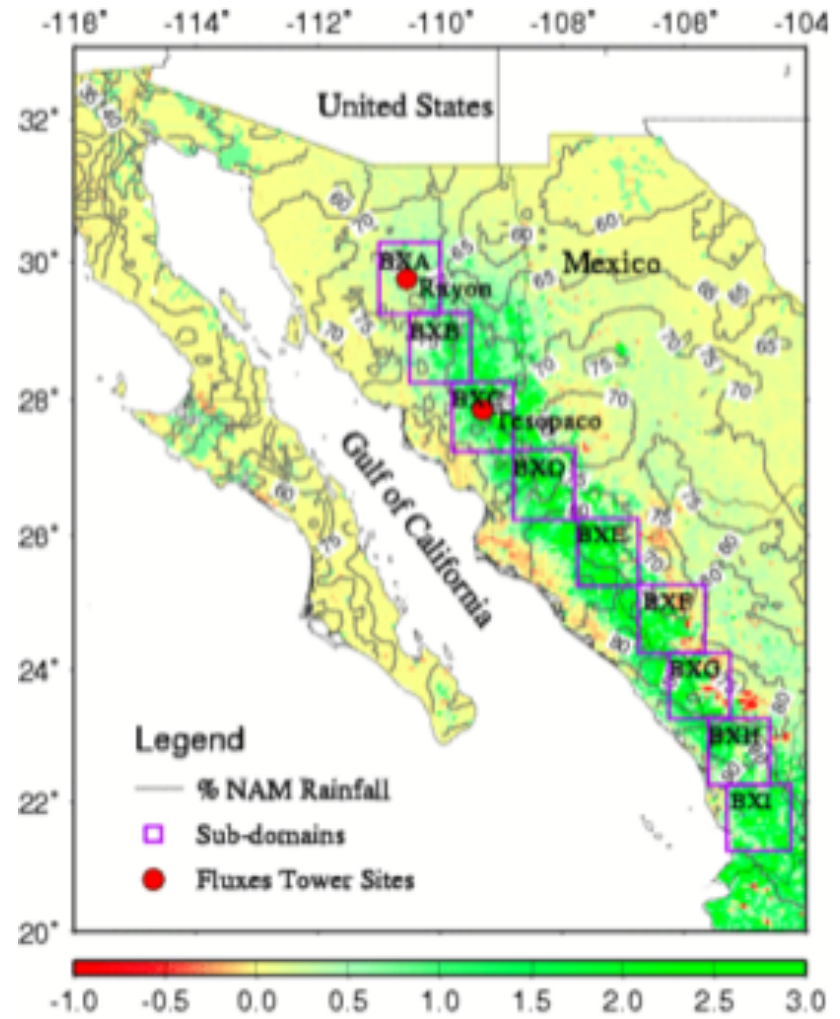
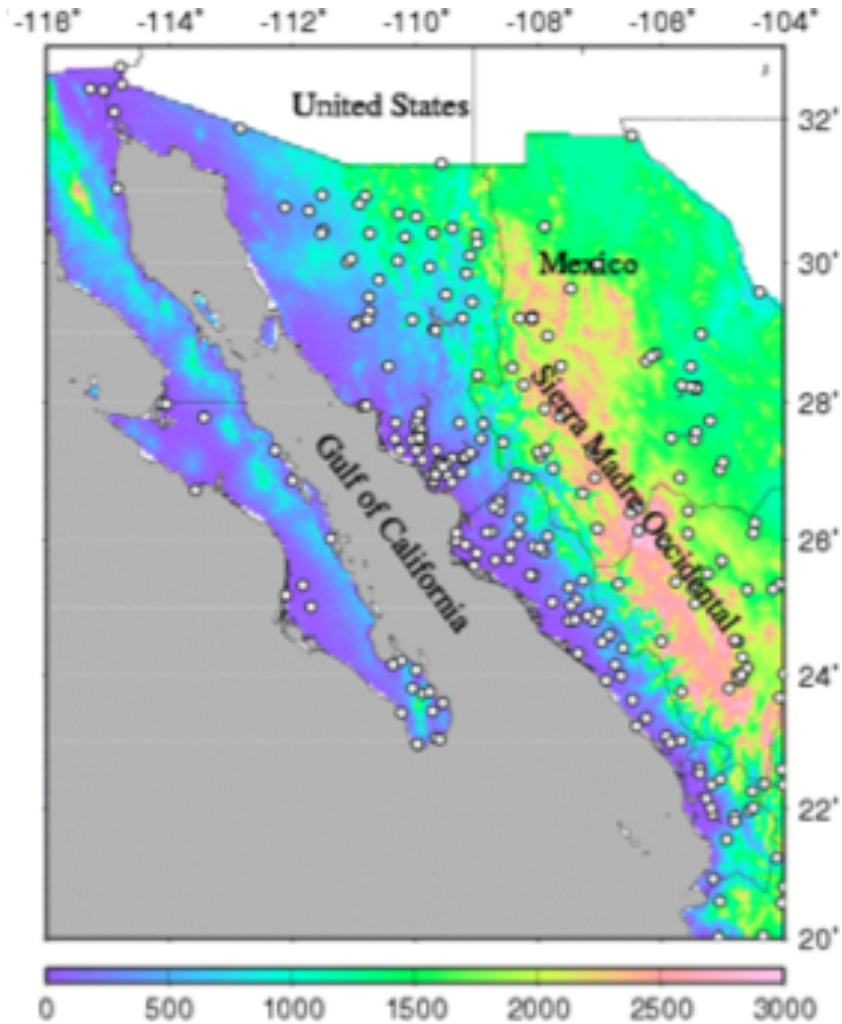

North American Monsoon Experiment (NAME) and the Soil Moisture Experiment (SMEX2004)

Water Cycle Components

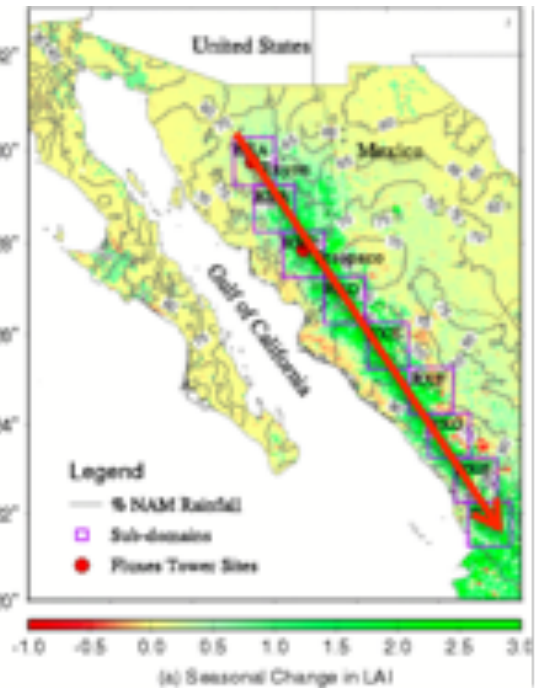
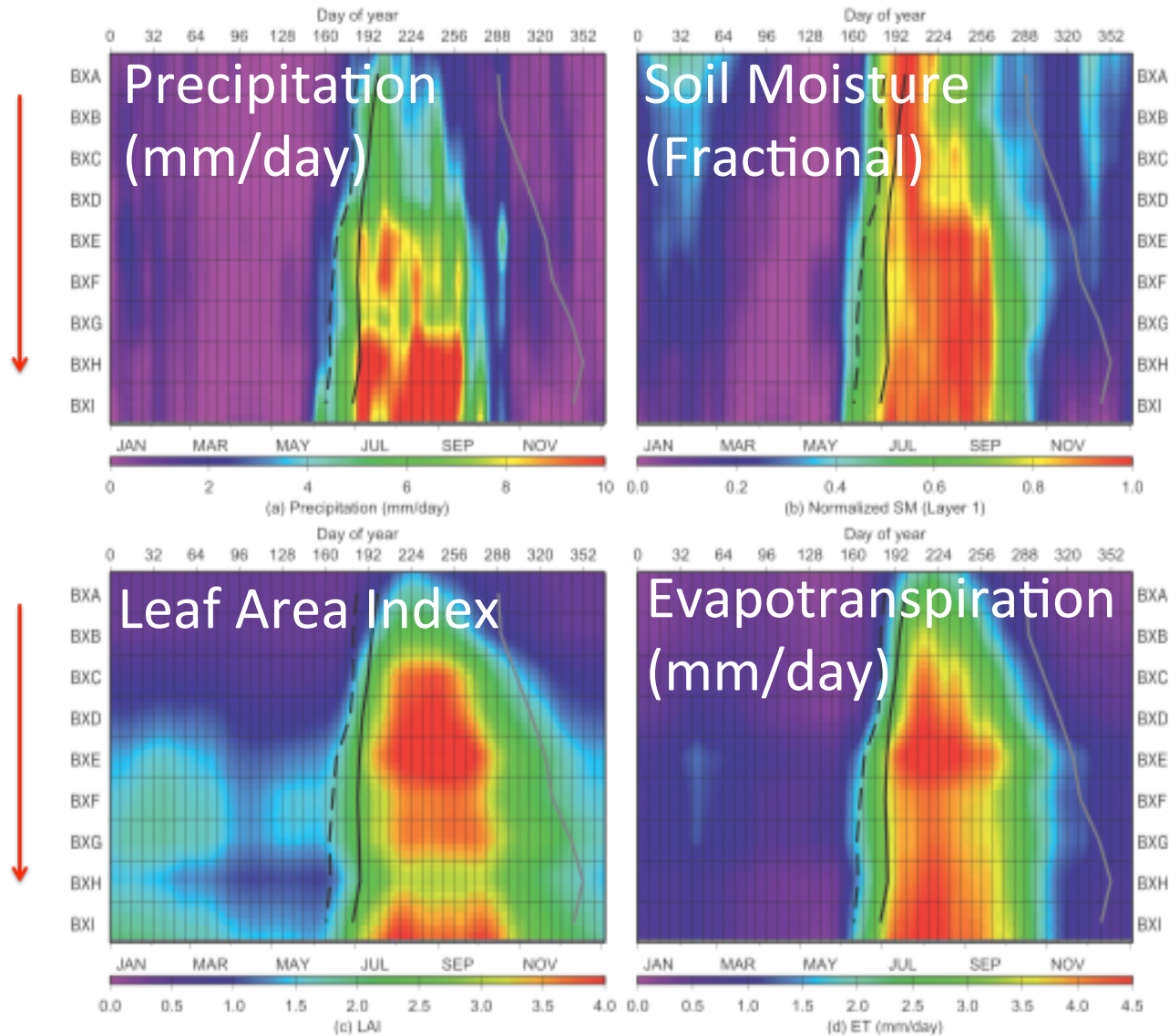

GW, ET, SW in California's Central Valley

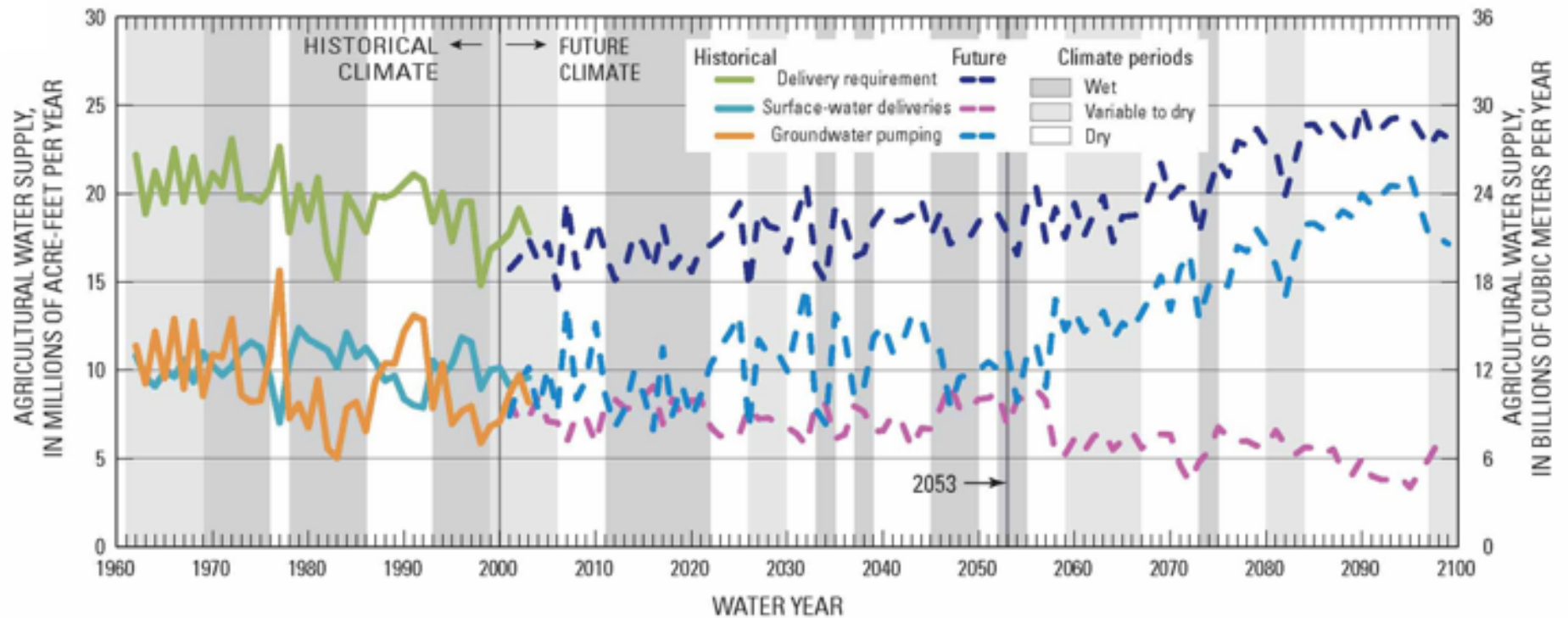

How useful are Weather/Climate?

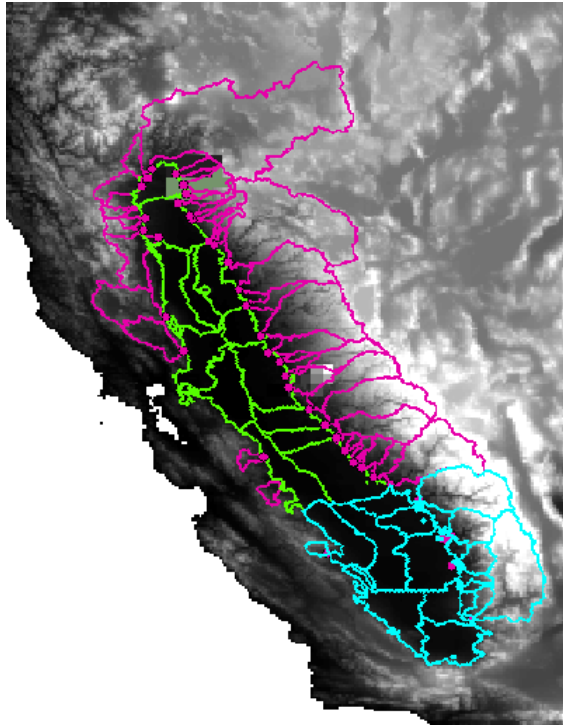

CA's Central Valley

Crop Irrigation Requirements

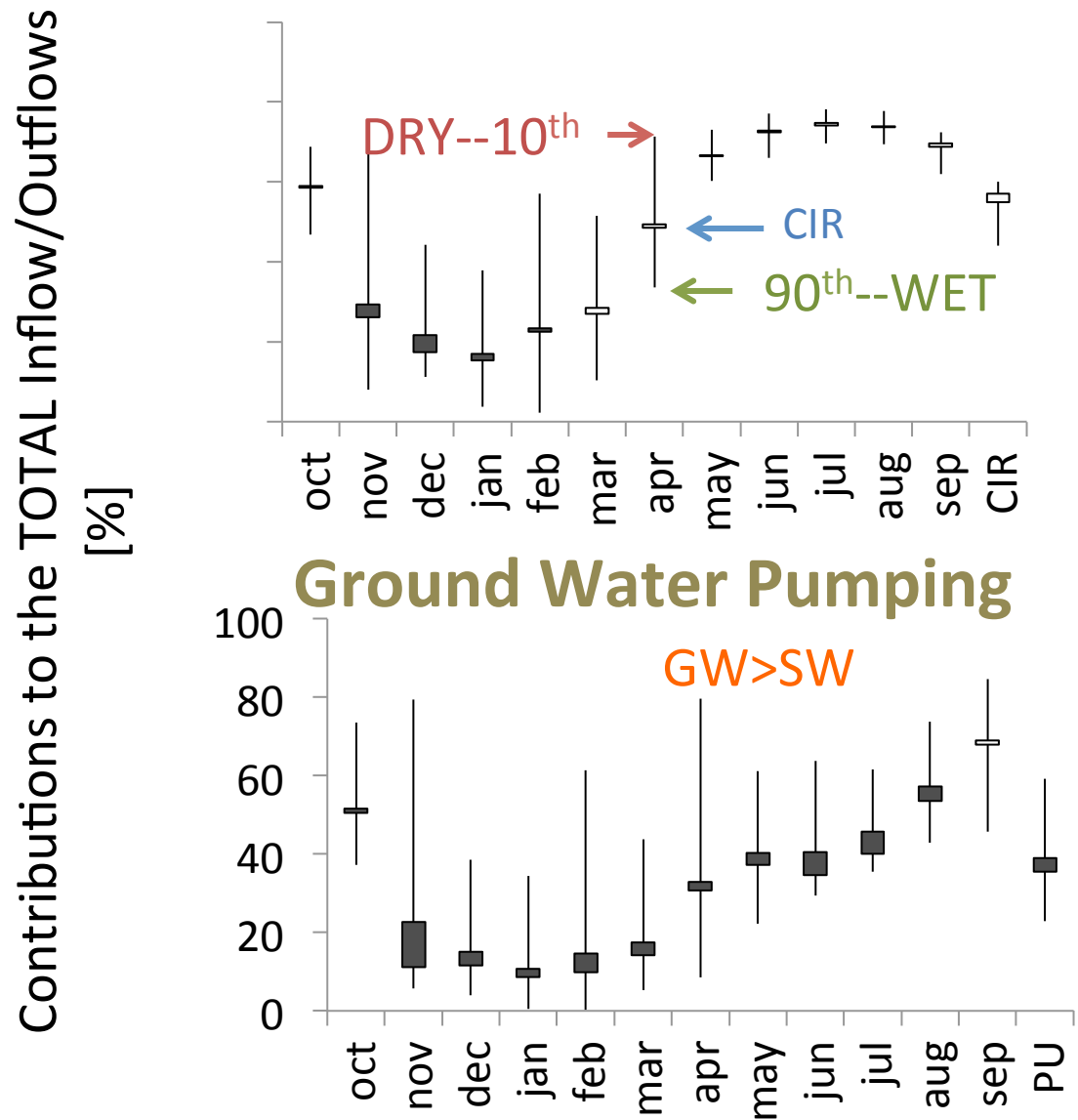

ET in the Platte River Basin

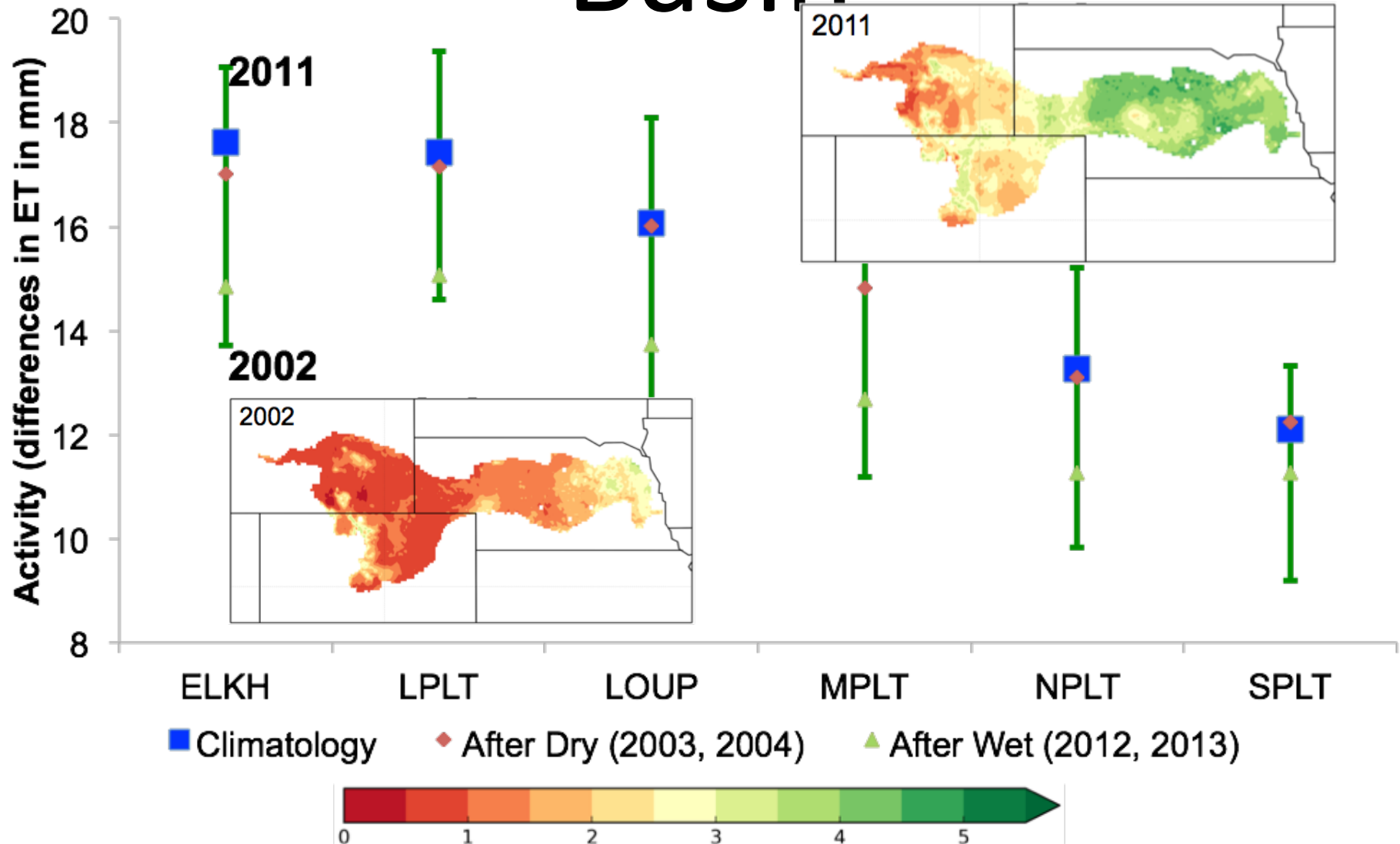

DATA

- Heterogeneous
- Massive
- Multidimensional
- A single meteorological remote sensor can produce 3 terabytes of data (equivalent to 1500 hours of movies) on a daily basis;
- Sixty years of climatological station (i.e. precipitation, minimum and maximum temperatures) 1 terabytes
- Sixty years gridded data for the North American sub-continent use 1 and 3 terabytes
- The historical record of annual corn production in the US could be stored in less than 1 terabyte

Datasets

Acronym	Dataset	Technique	Reference
USMEX	US and Mexican Daily Precipitation Analysis	Rain Gauge	Higgins et al. (2000)
UWAS	University of Washington	Rain Gauge	Maurer et al. (2002) and Zhu and Lettenmaier (in press)
GR	National Centers for Environmental Prediction (NCEP) Global Reanalysis	Modeling	Kalnay et al. (1996)
RR	National Centers for Environmental Prediction (NCEP) North American Regional Reanalysis	Modeling	Messinger (2003)
3B42	Tropical Rainfall Measuring Mission (TRMM) 3B42	Merged	Kummerow et al. (2000)
GPI	GOES Precipitation Index	IR/VIS	Arkin and Meissner (1987)
GPCP	Global Precipitation Climatology Project	Merged	Huffman et al. (2001)

Uncertainty

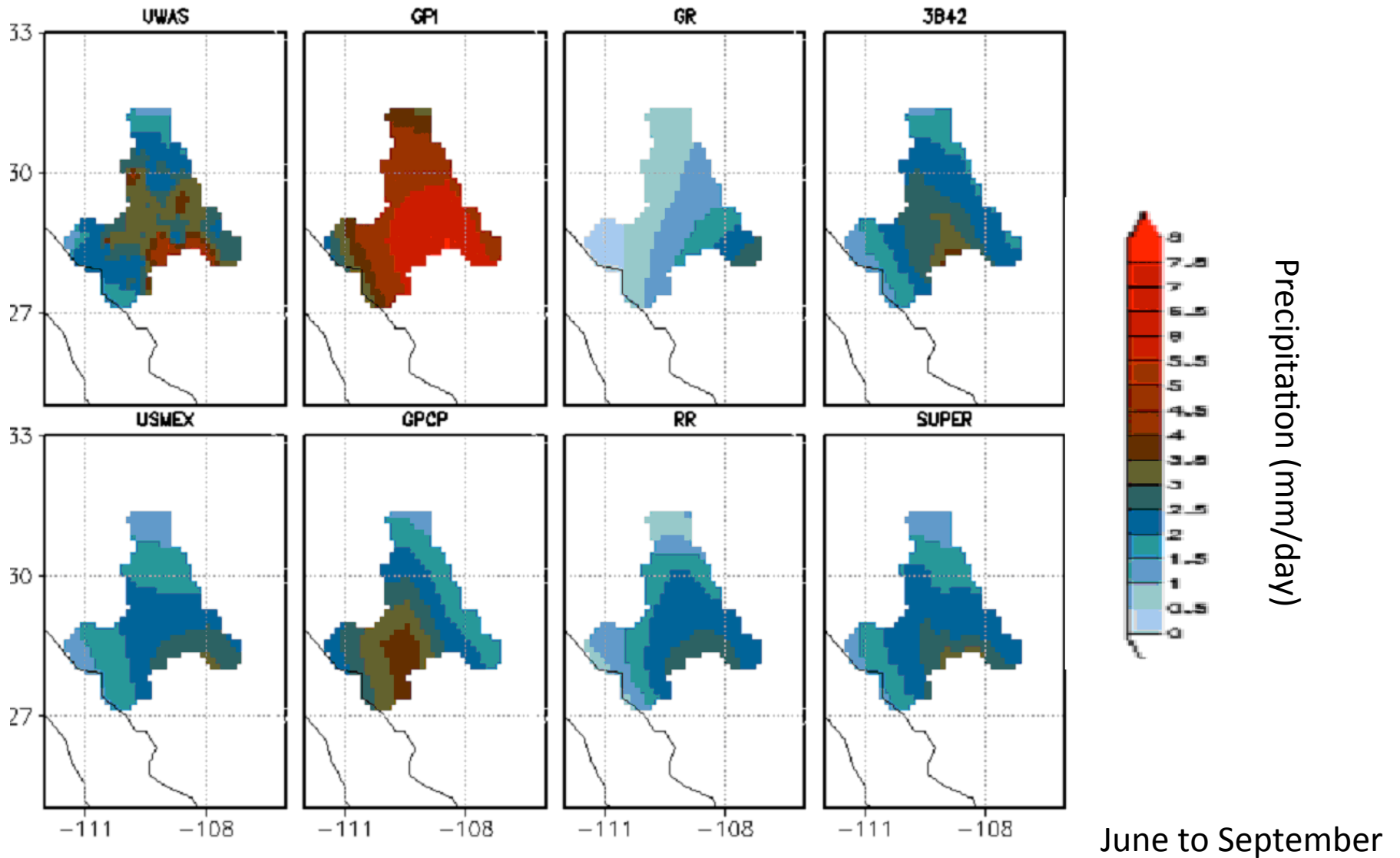

Uncertainty

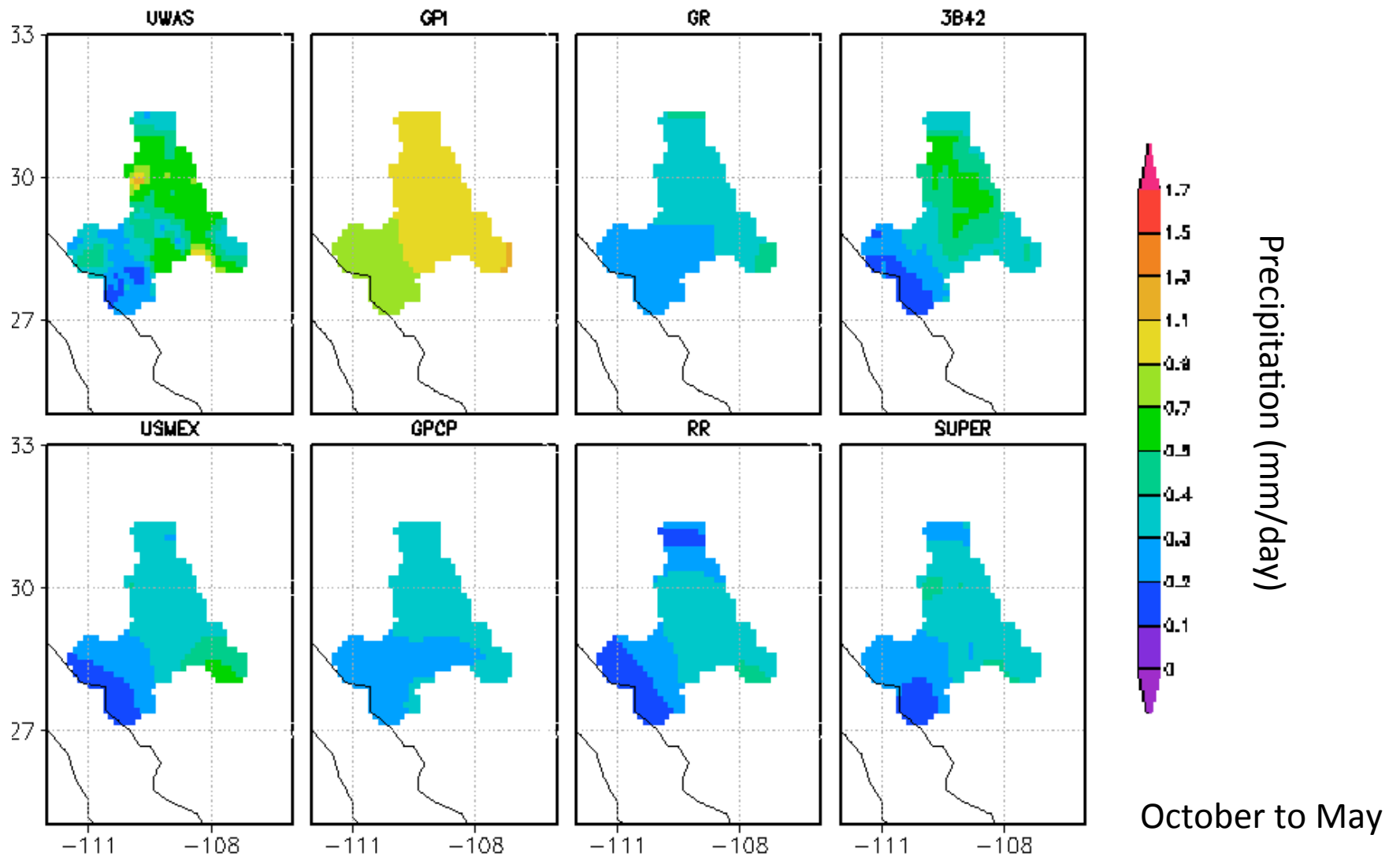

Propagation of Uncertainty

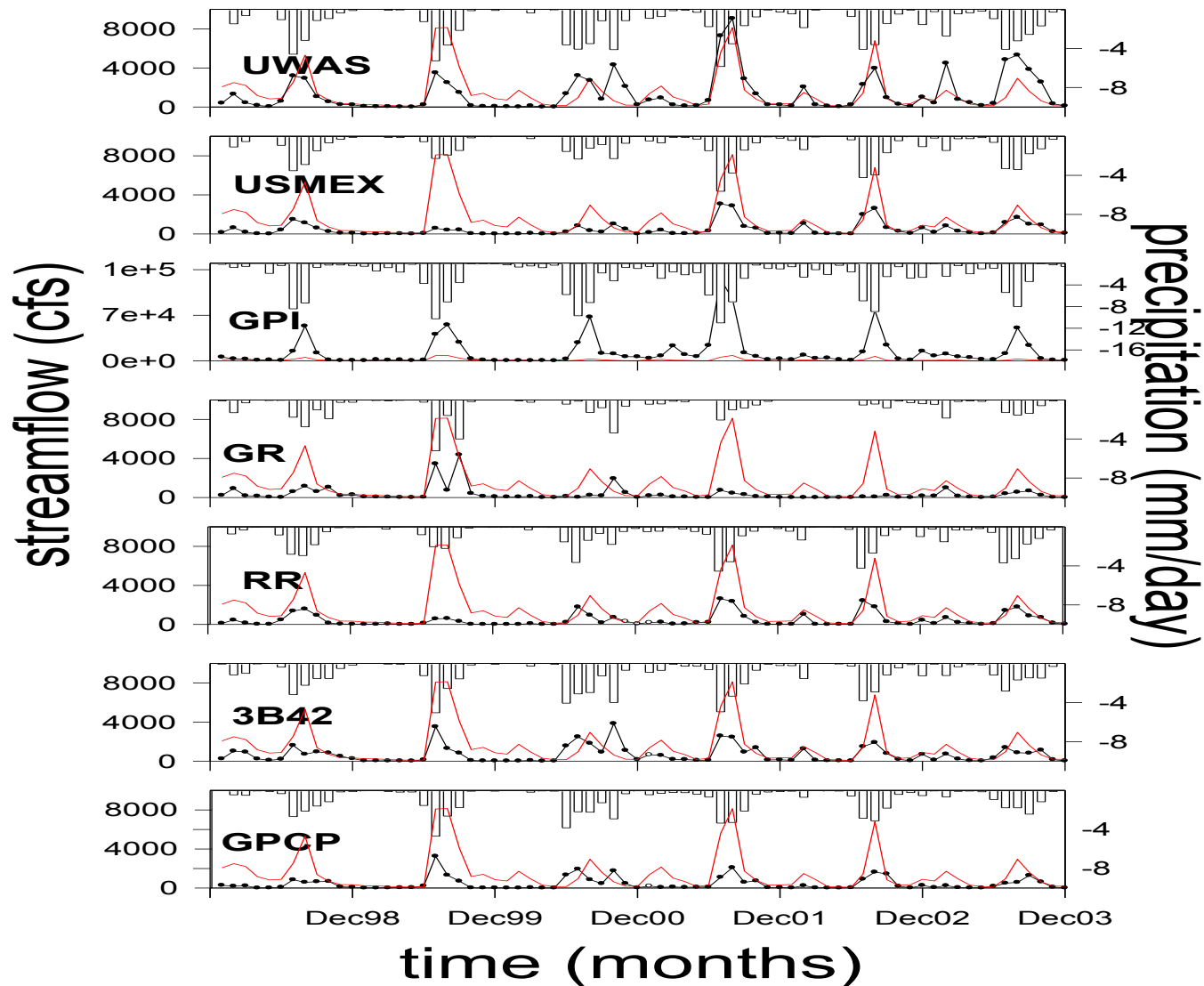

Historical Average or Climatology

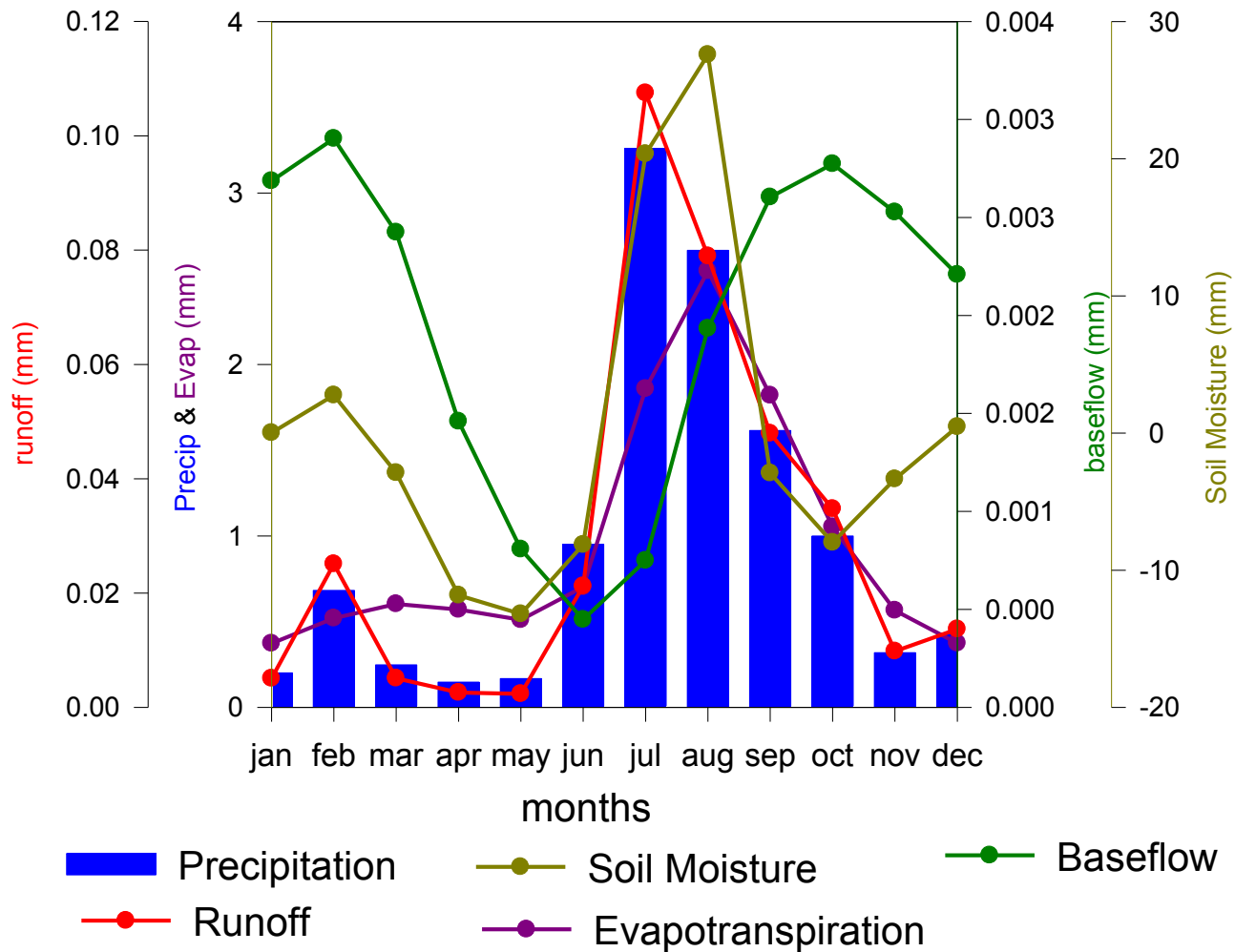

Datasets

- Gridded Data (Livneh and CMAP)
- Station Data (HPRCC and GHCN)

<http://www.esrl.noaa.gov/psd/data/gridded/>

<http://www.esrl.noaa.gov/psd/data/gridded/data.cmap.html>

Livneh et al (2015)

Take-home Message

- Identify the mechanisms that describe the interdependence between Climate and Water Systems
 - Water and agricultural resources sustainability
 - Growing Urban needs
 - Preservation of ecosystem services
 - Climate change
- What tools/activities will continue (or enhance) stakeholders' involvement in data and information improvement?

The Other Water cycle



Appendix 4



Discussion 2

Data Management, Integration, and Uncertainty

Hydroclimatology

NRES/MTR/*BSEN 479/879

Francisco Munoz-Arriola^{1,2,3,4,5}

¹Biological Systems Engineering Department

²School of Natural Resources

³Earth and Atmospheric Sciences Department

⁴Robert B. Daugherty Water for Food Institute- Fellow

⁵United States Geological Survey-Volunteer for Science

February 11th 2016

Outline

- The hydroclimatic context (or “complex”)
- Objectives
- Hydro-climate drivers and representation
- Integration
- Uncertainty in hydroclimatologic modeling: a “big picture” forward
 - Calibration
 - Sources of uncertainty
 - Types of uncertainty intervals
 - From Forward to Bayesian Statistics
- Management

Where to start?

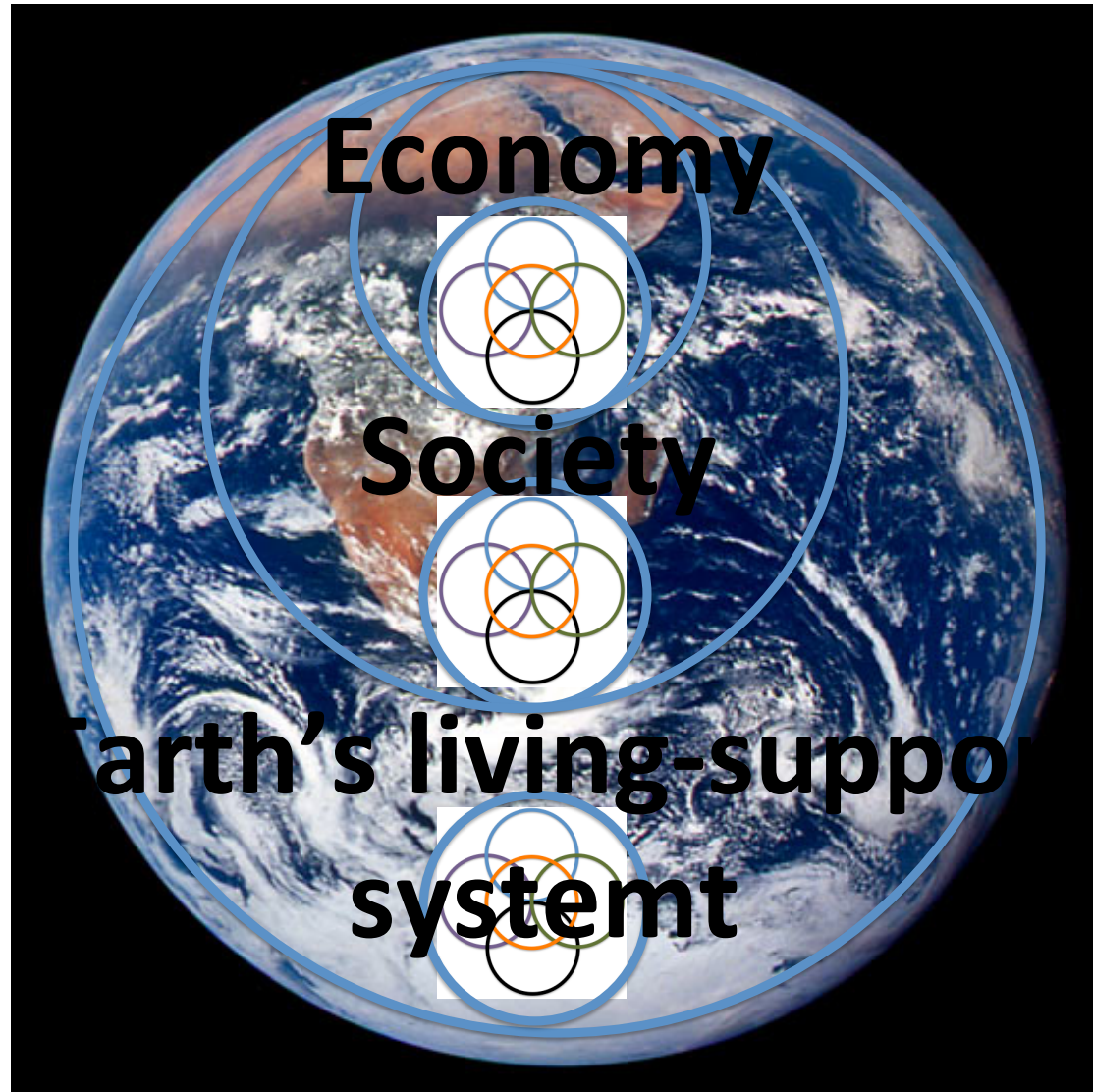

Where do we go?

Historical

Future

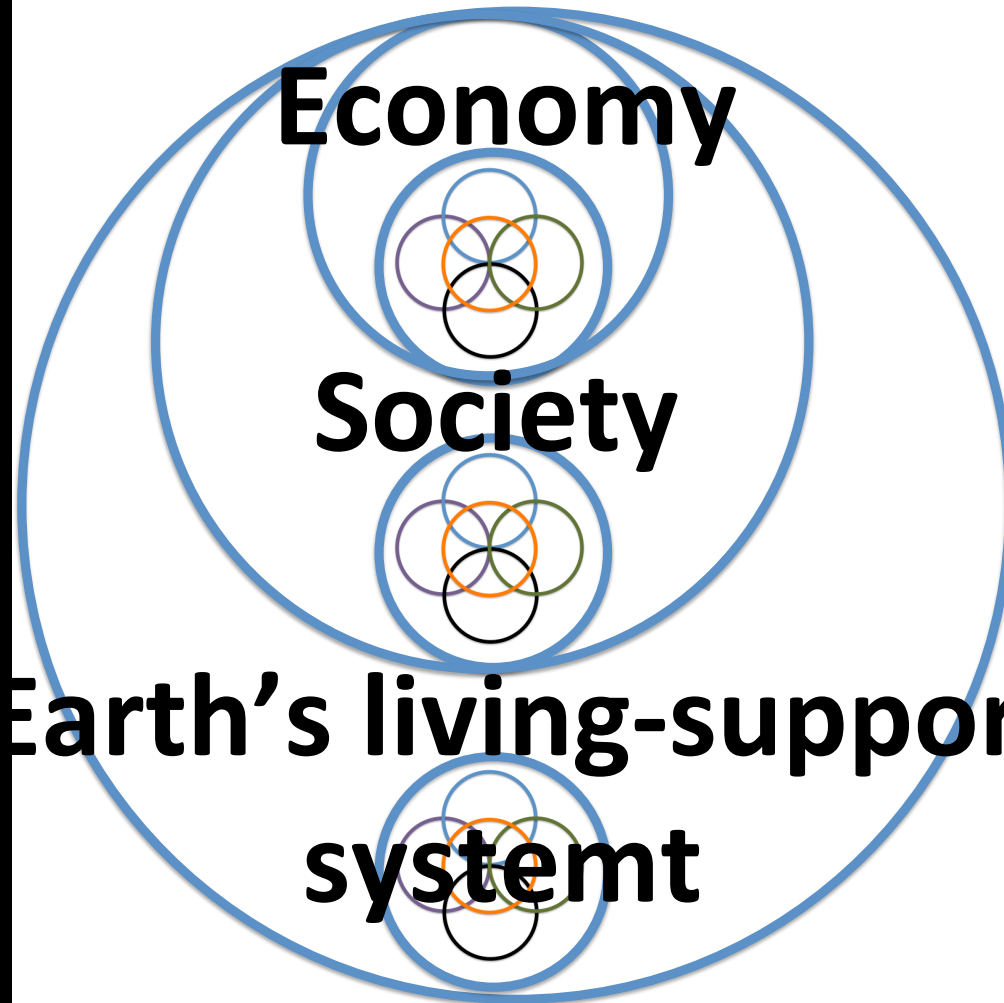
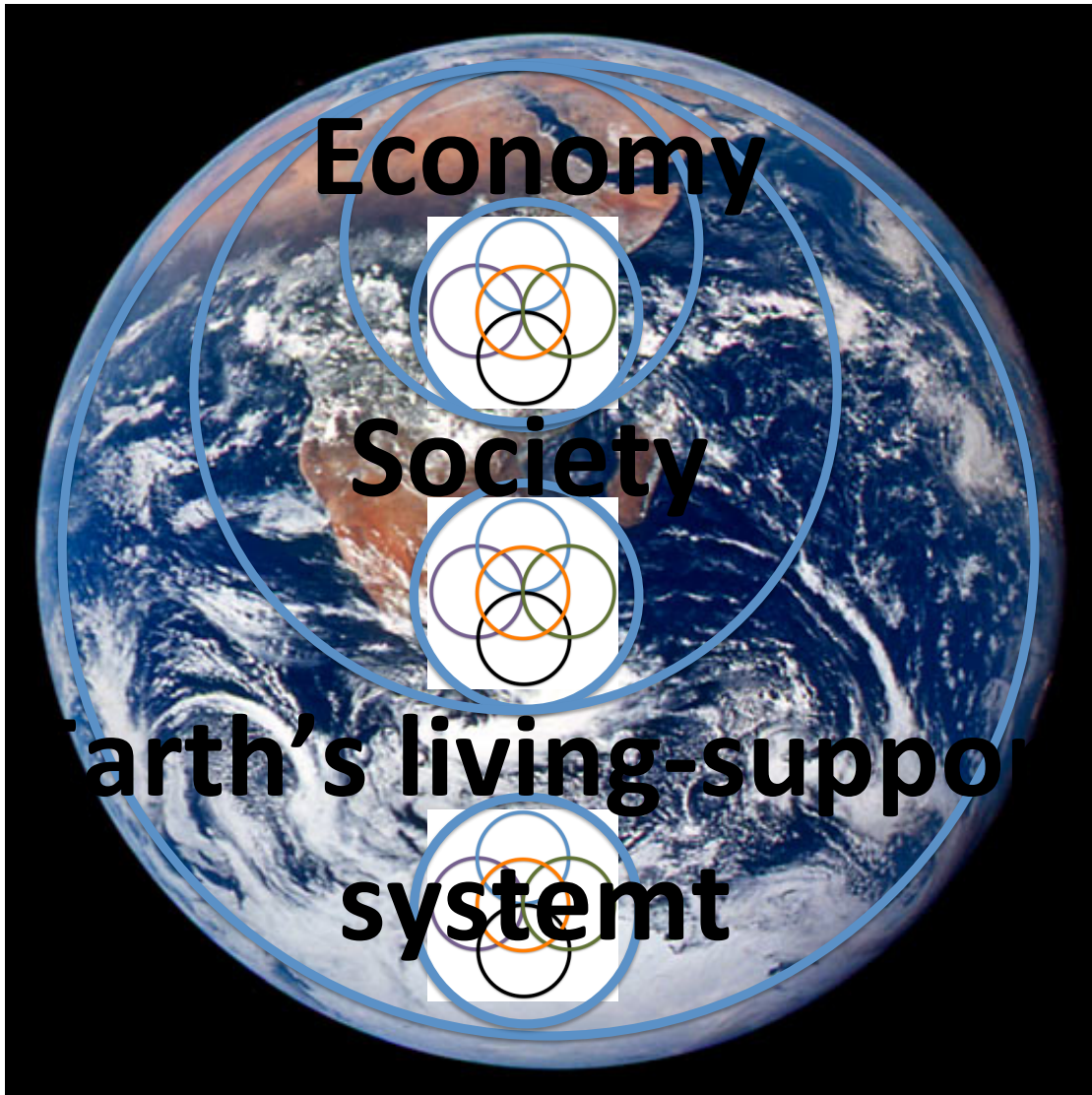

Where are our data?

Historical

Future

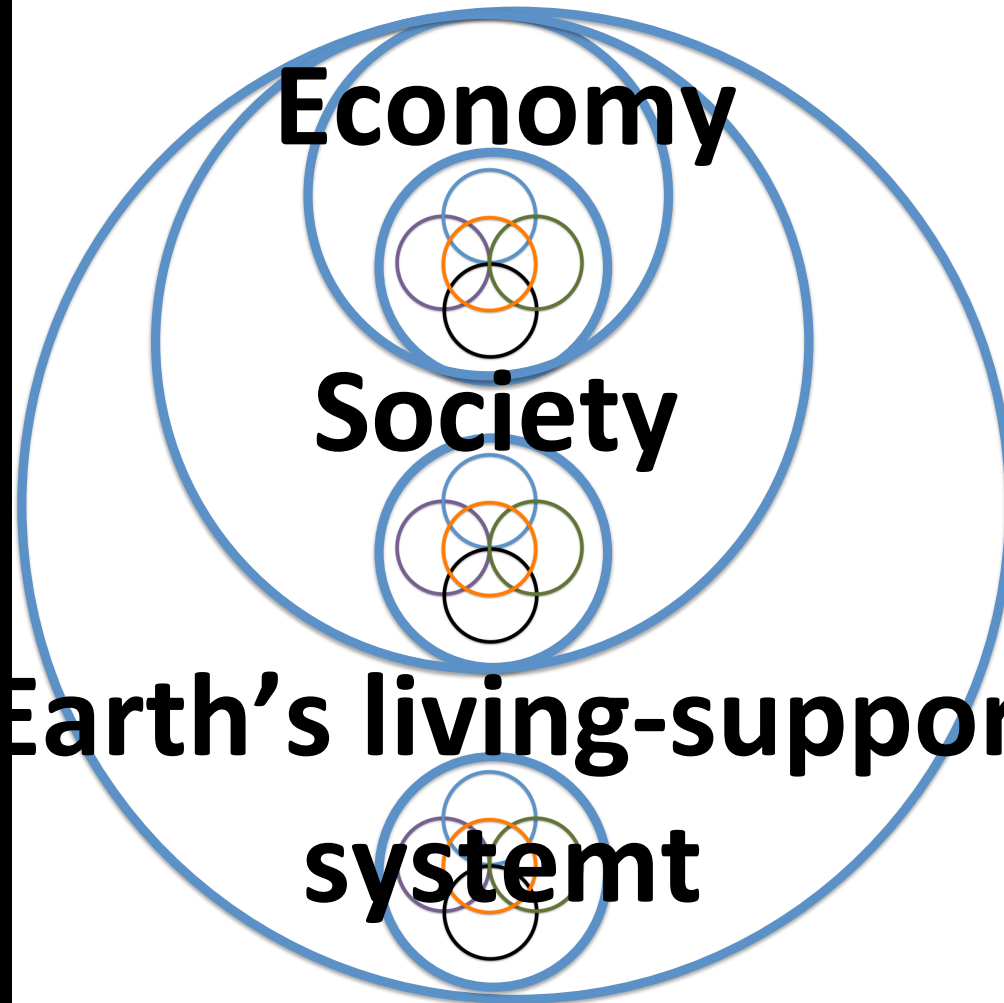
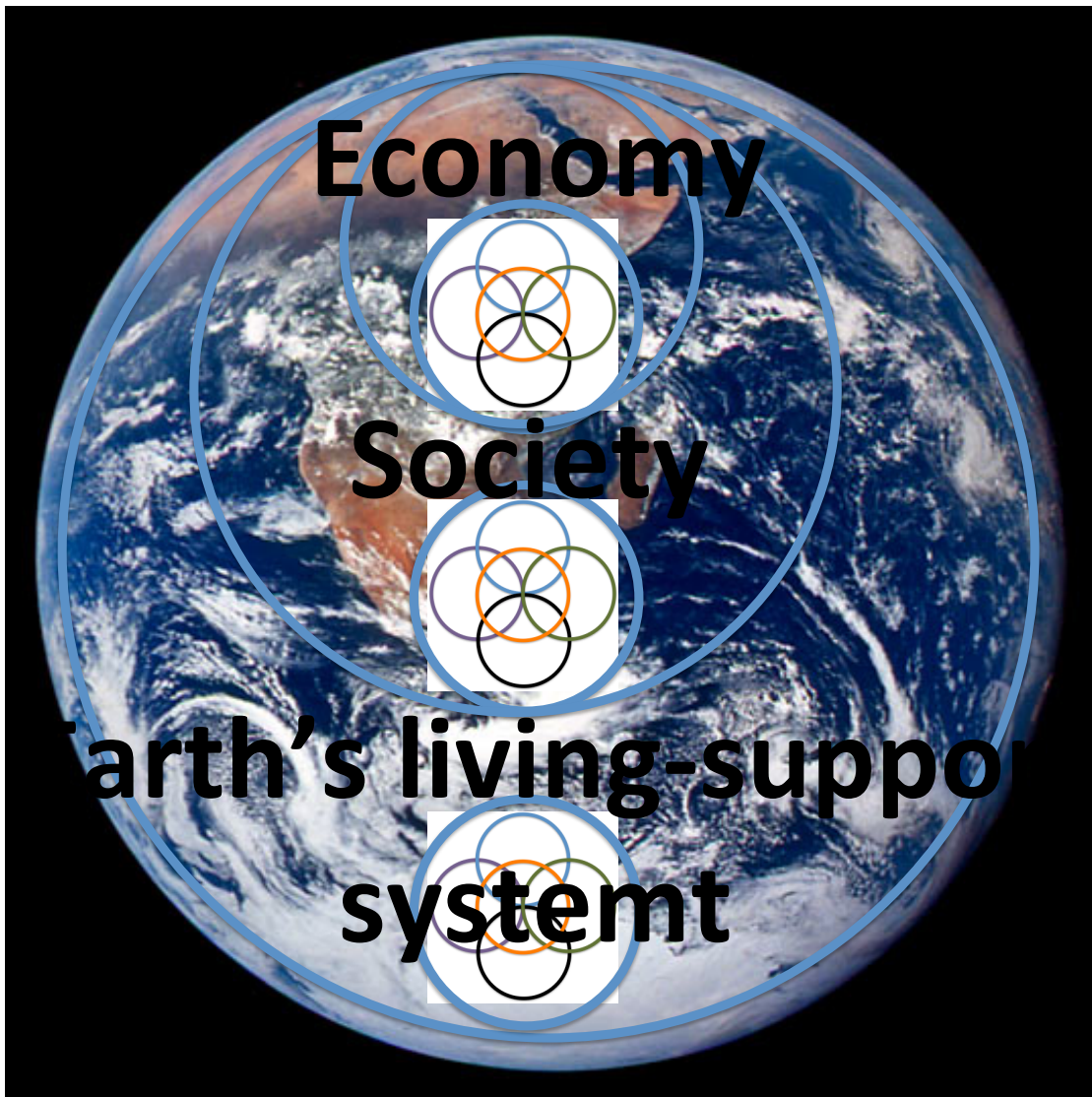

Integration, Management, and Uncertainty

Historical

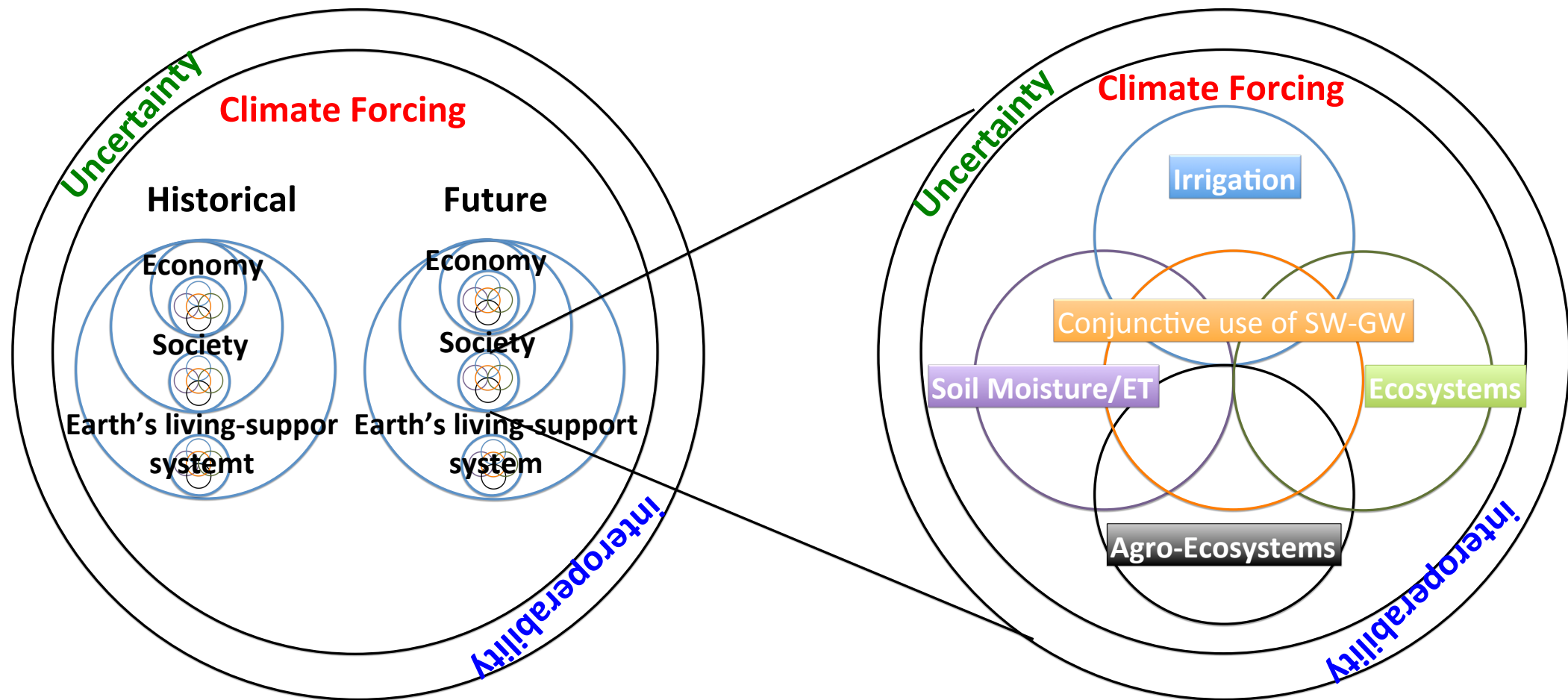

Objective

- Conceptualize data integration, uncertainty, and management in hydroclimatology

System Integration

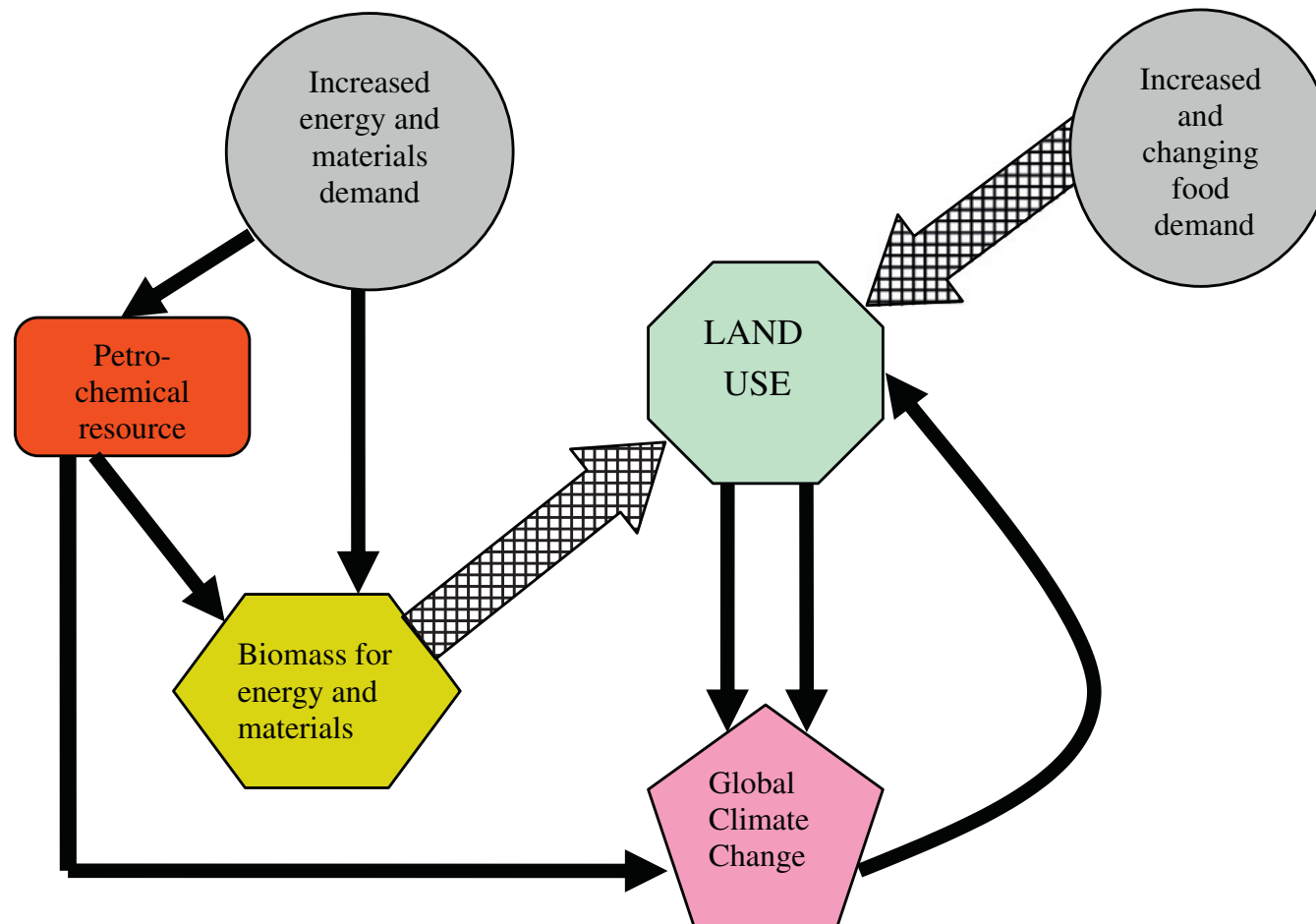

System Integration

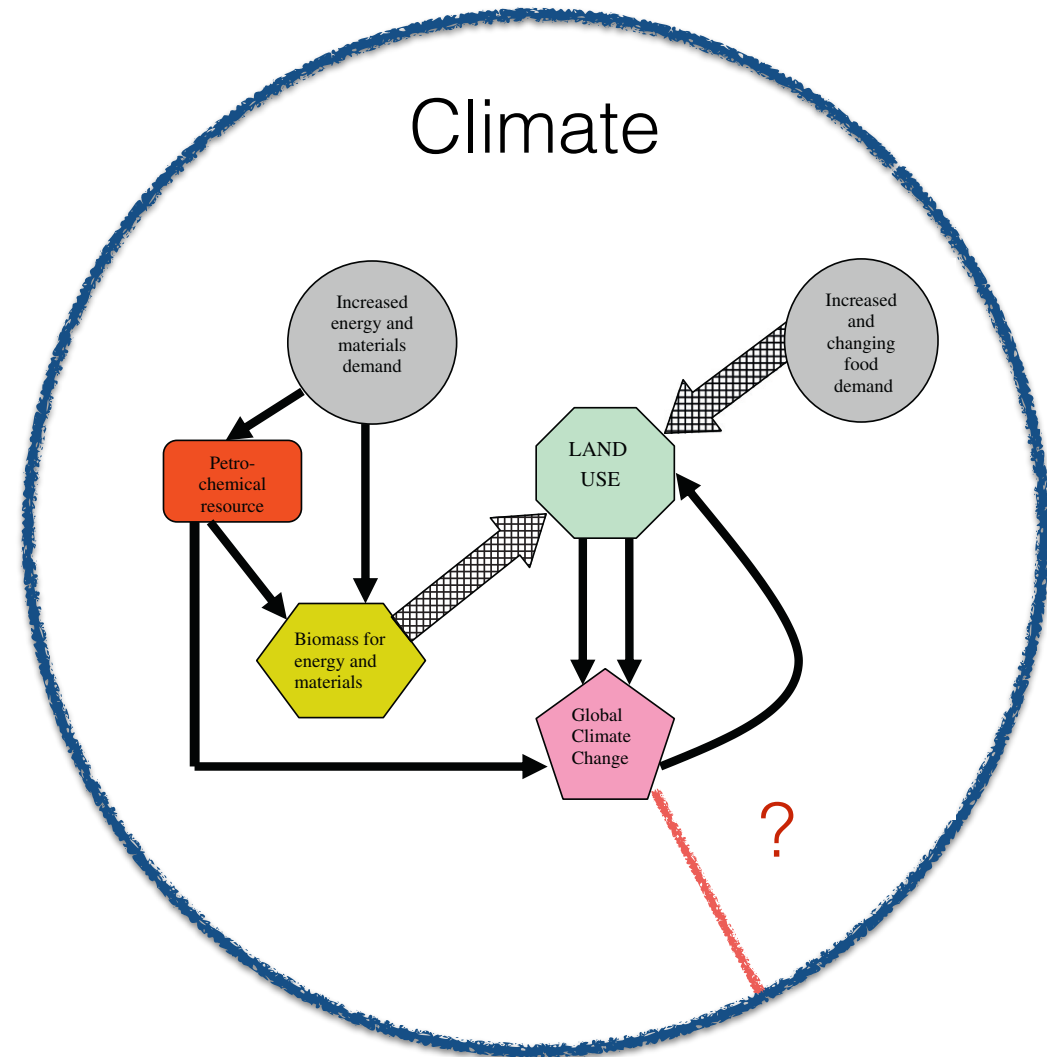
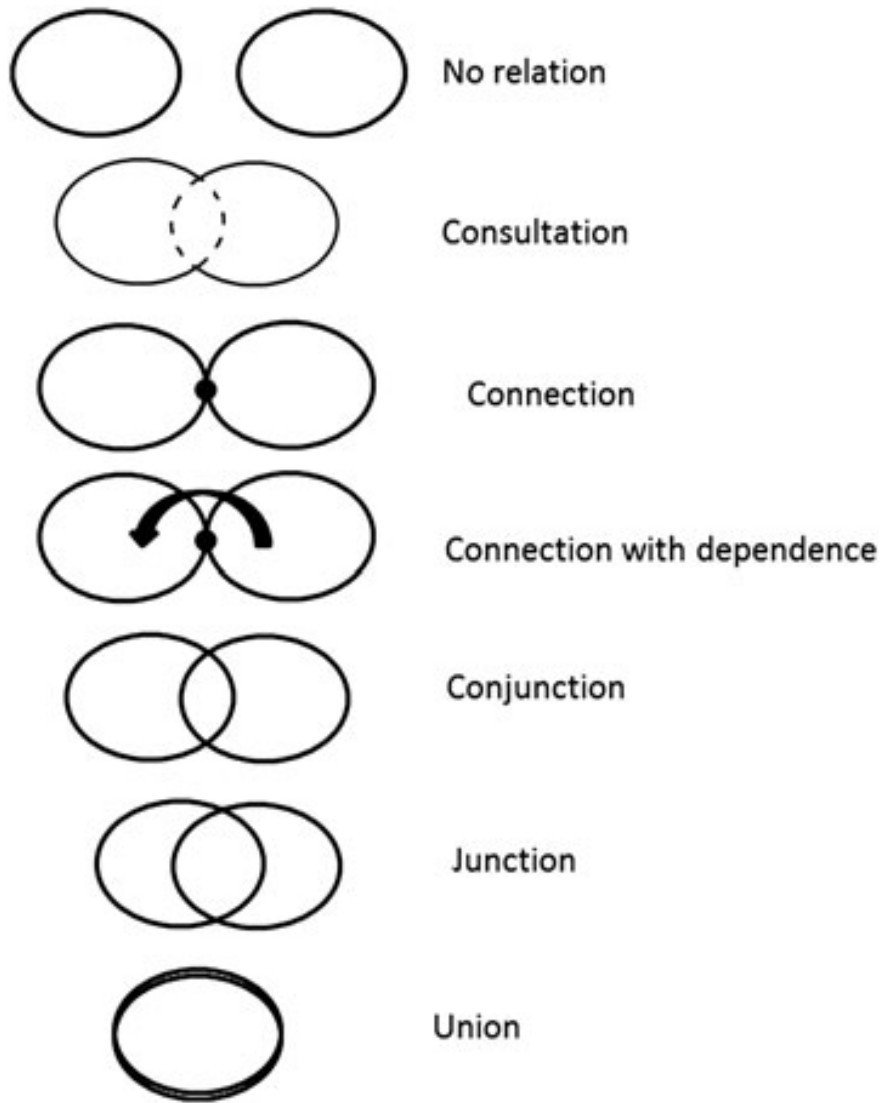

Temporal Changes

Planted area: Corn, wheat, and soybeans

Million acres

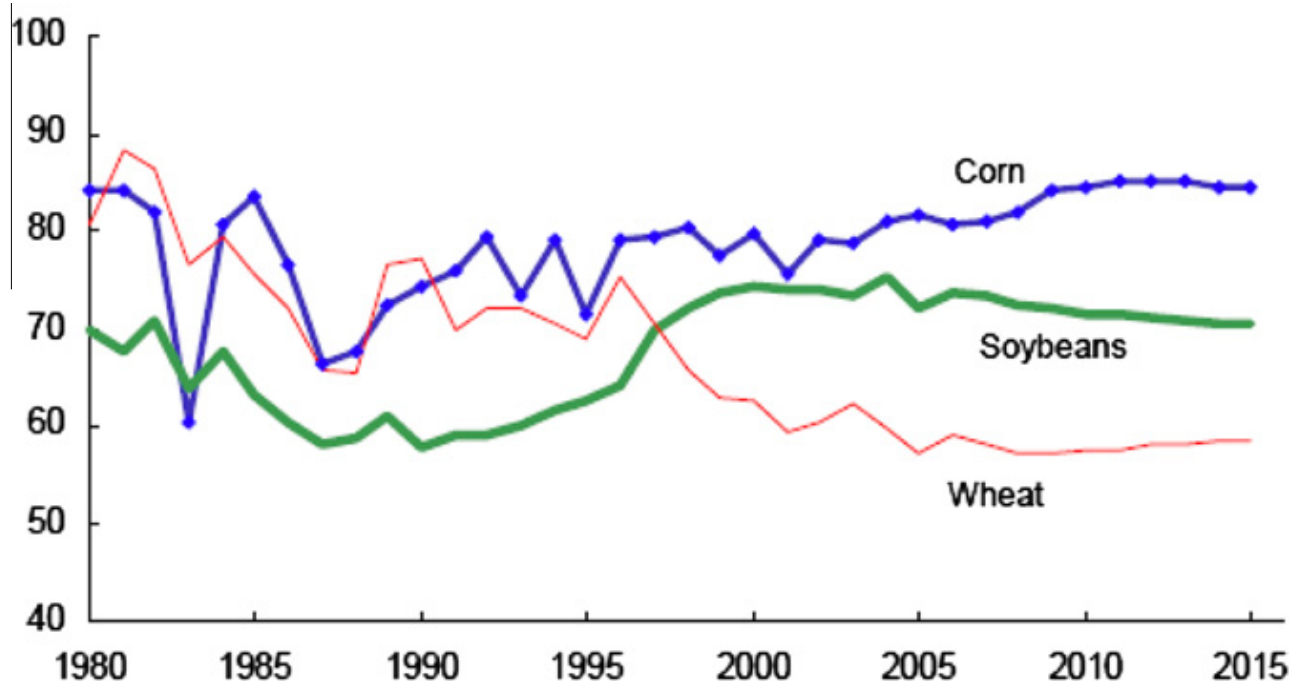

The Challenge of scales

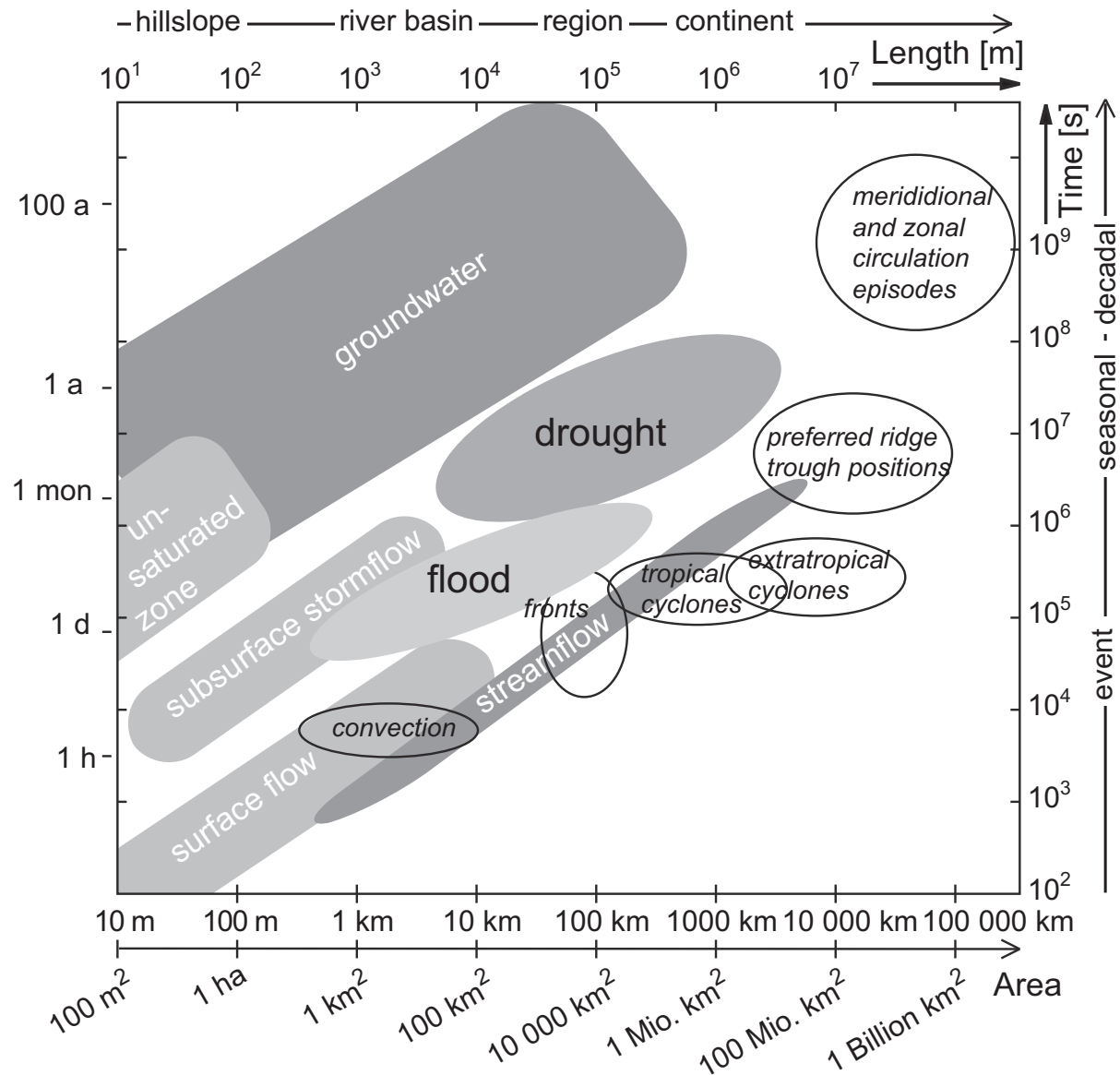

Lets choose hydrologic modeling to accomplish our objective

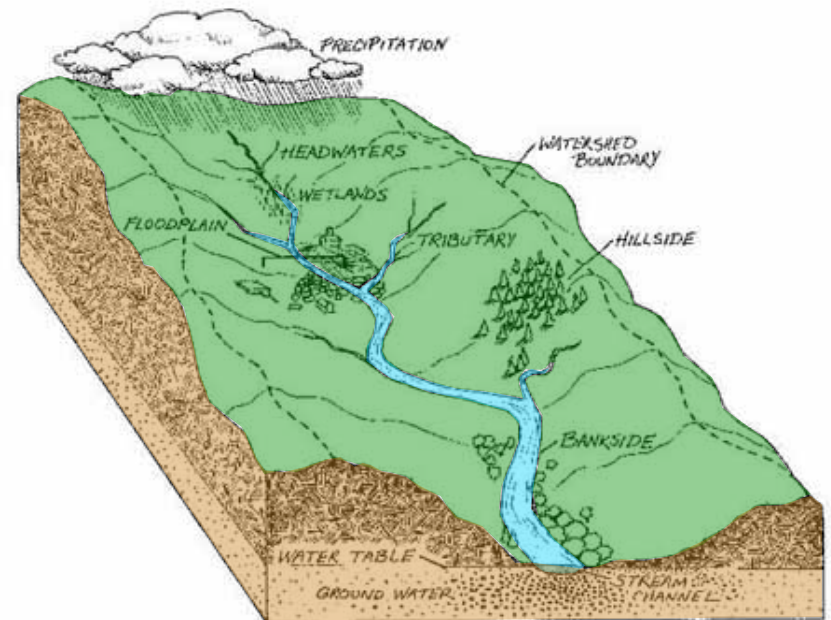

Watershed—Definition

The area that contributes all the water that drains to a given **cross section** of a stream

- The surface trace of the boundary that delimits a watershed is called a **divide**
- The horizontal projection of the area of the watershed is called the **drainage area** of the stream at (or above) the cross-section

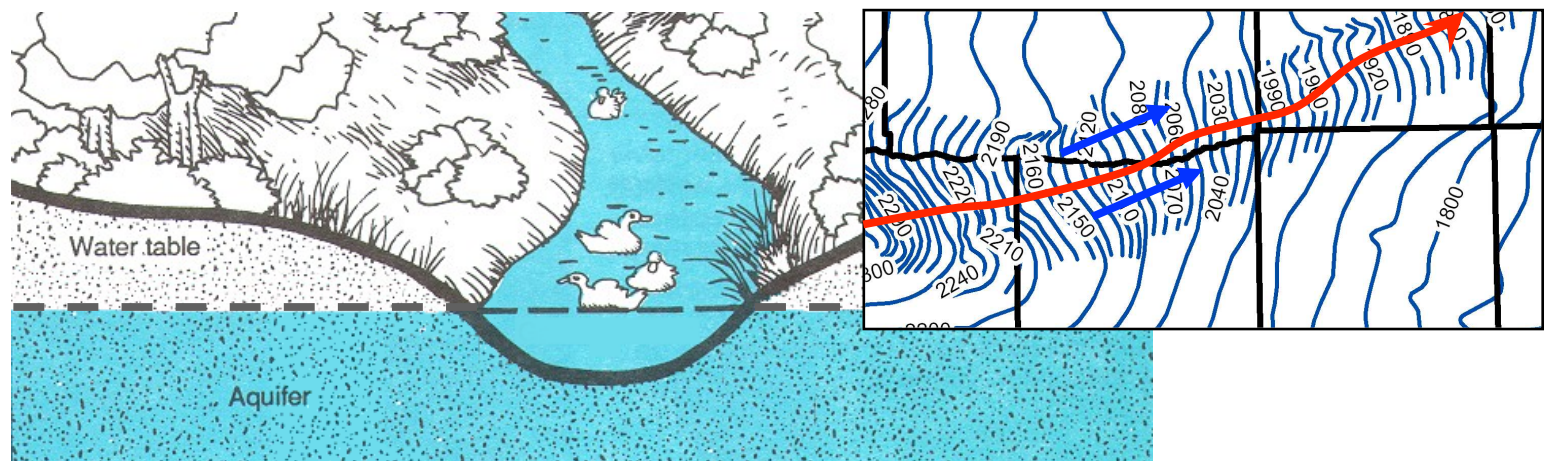

Streamflow and Climate

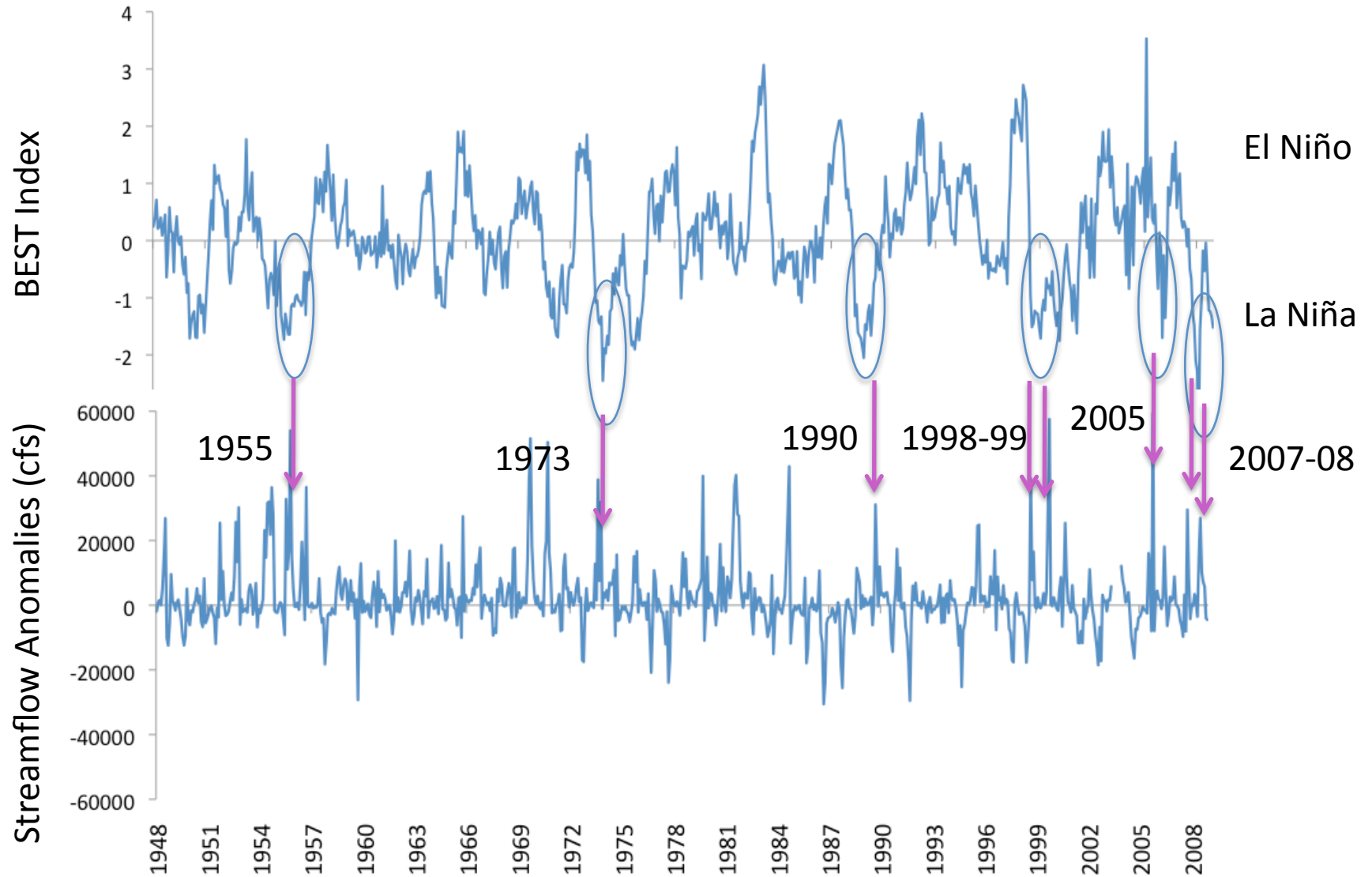

Handling Model Calibration or Conditioning

- Optimum Parameter
- Uncertainty Estimation
- Model Calibration and Uncertainty Estimation
- Model Conditioning and Equifinality

Observations vs. Simulations

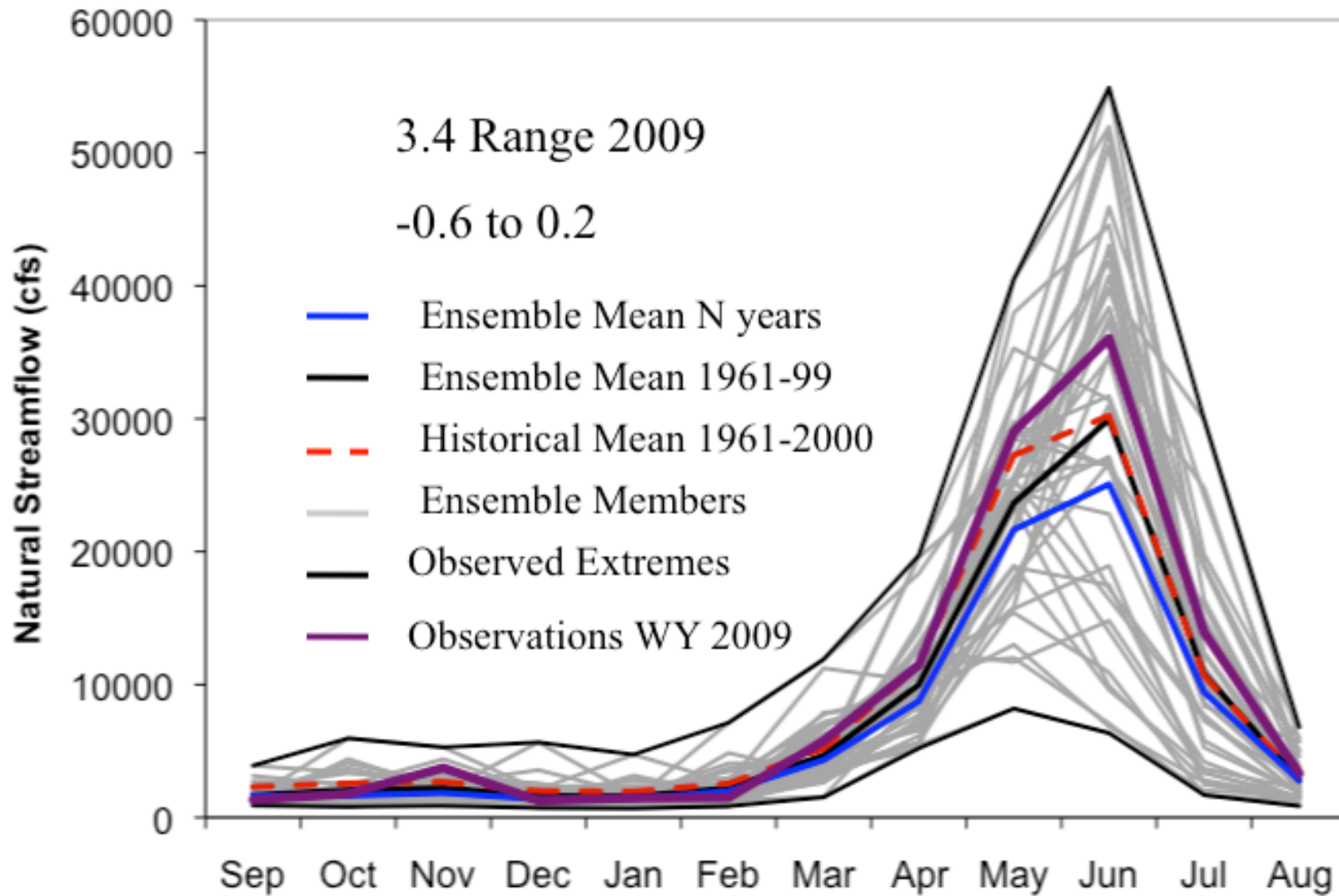

Statistics

- Sum of squared errors or error variance
 - May result in over-prediction or under-prediction

$$\sigma_{\varepsilon}^2 = \frac{1}{T-1} \sum_{t=1}^T (\hat{y}_t - y_t)^2$$

- Nash-Sutcliffe Efficiency Index
 - Statistical coefficient of determination

$$E = \left[1 - \frac{\sigma_{\varepsilon}^2}{\sigma_o^2} \right]$$

Calibration

Parameter Response Surface

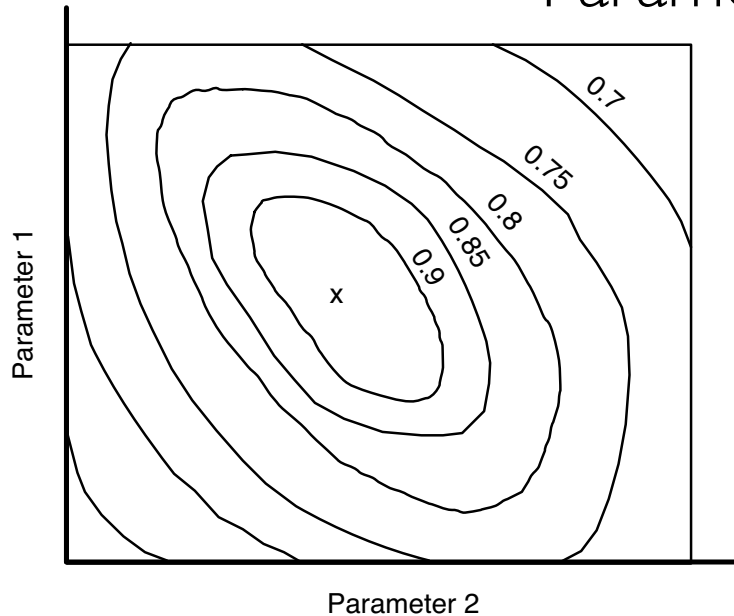

or

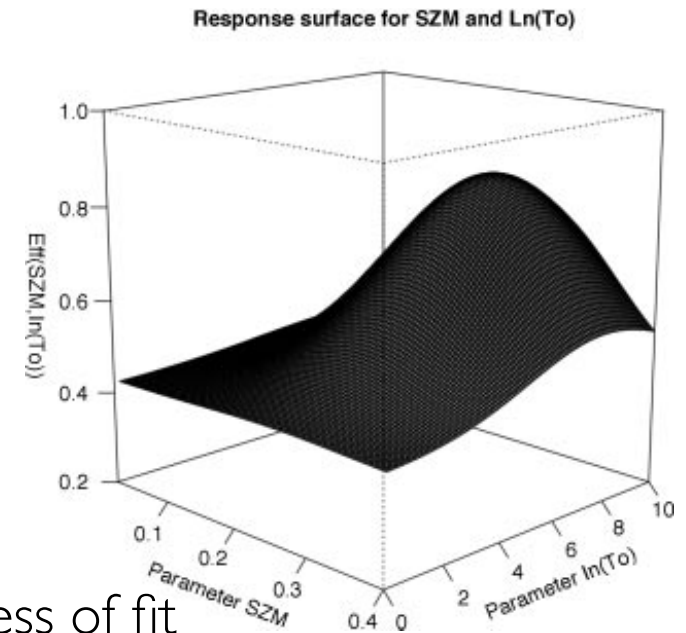

Based on values of goodness of fit

- Analytical estimated response surfaces are practically impossible (because requires knowledge of model outputs w.r.t. each parameter value @ every point)
- “Direct search” algorithms are used to sample the gradient of parameter(s) response surface(s)

Sources of Uncertainty

Physics of the Model

HEC-HMS

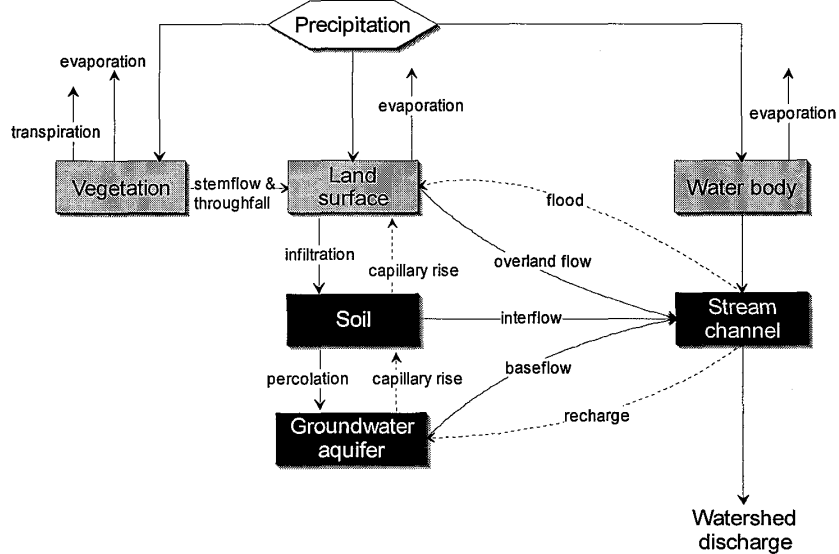
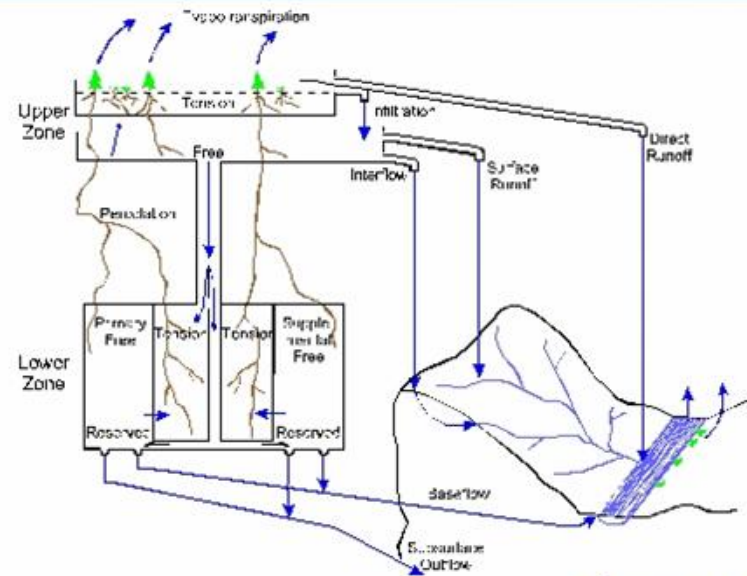

Figure 3-1. Systems diagram of the runoff process at local scale (after Ward, 1975)

Sacramento Soil Moisture Accounting Model



Initial and Boundary Conditions, and Forcings

ICs

Lead-time

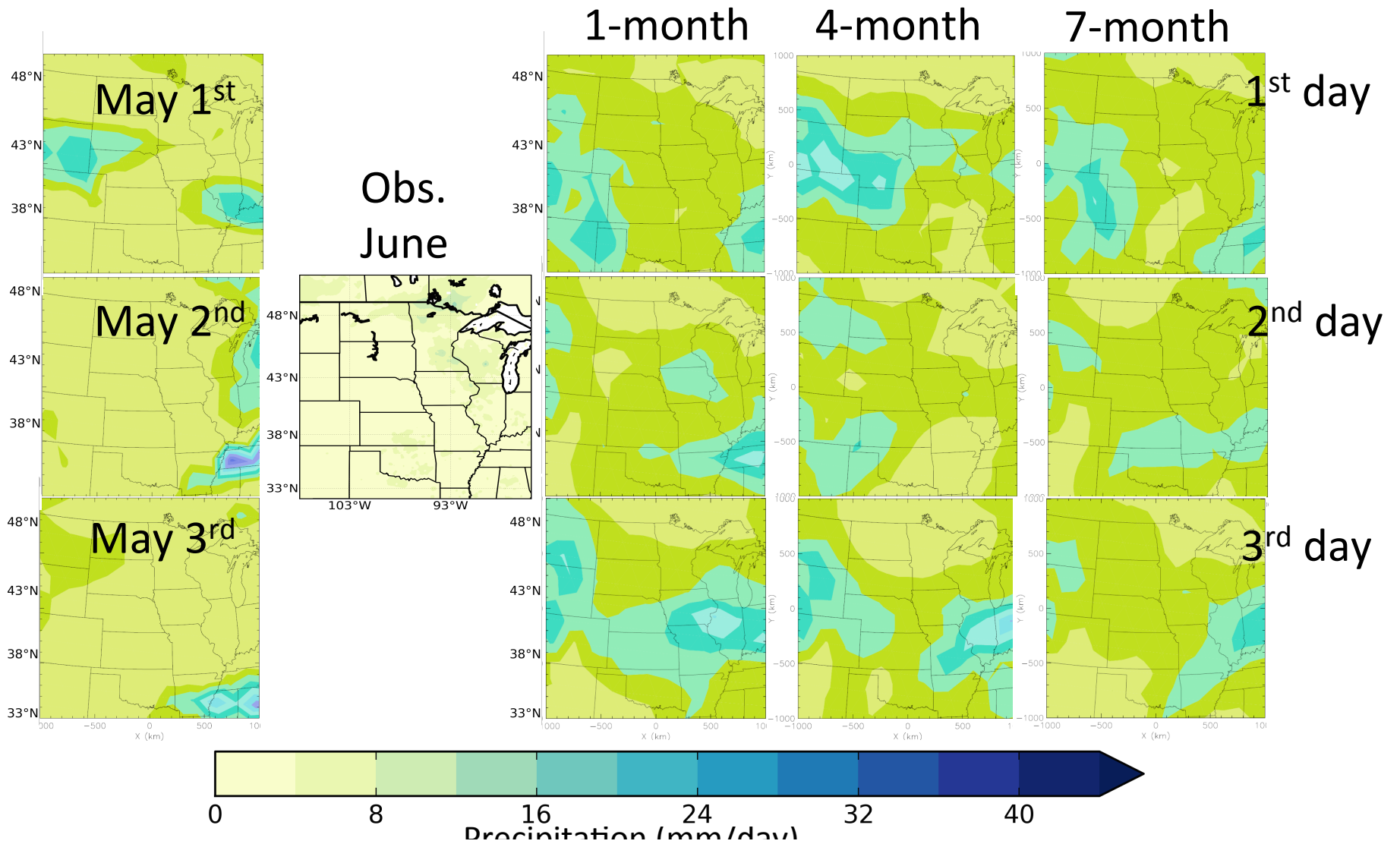

Parameter Estimation

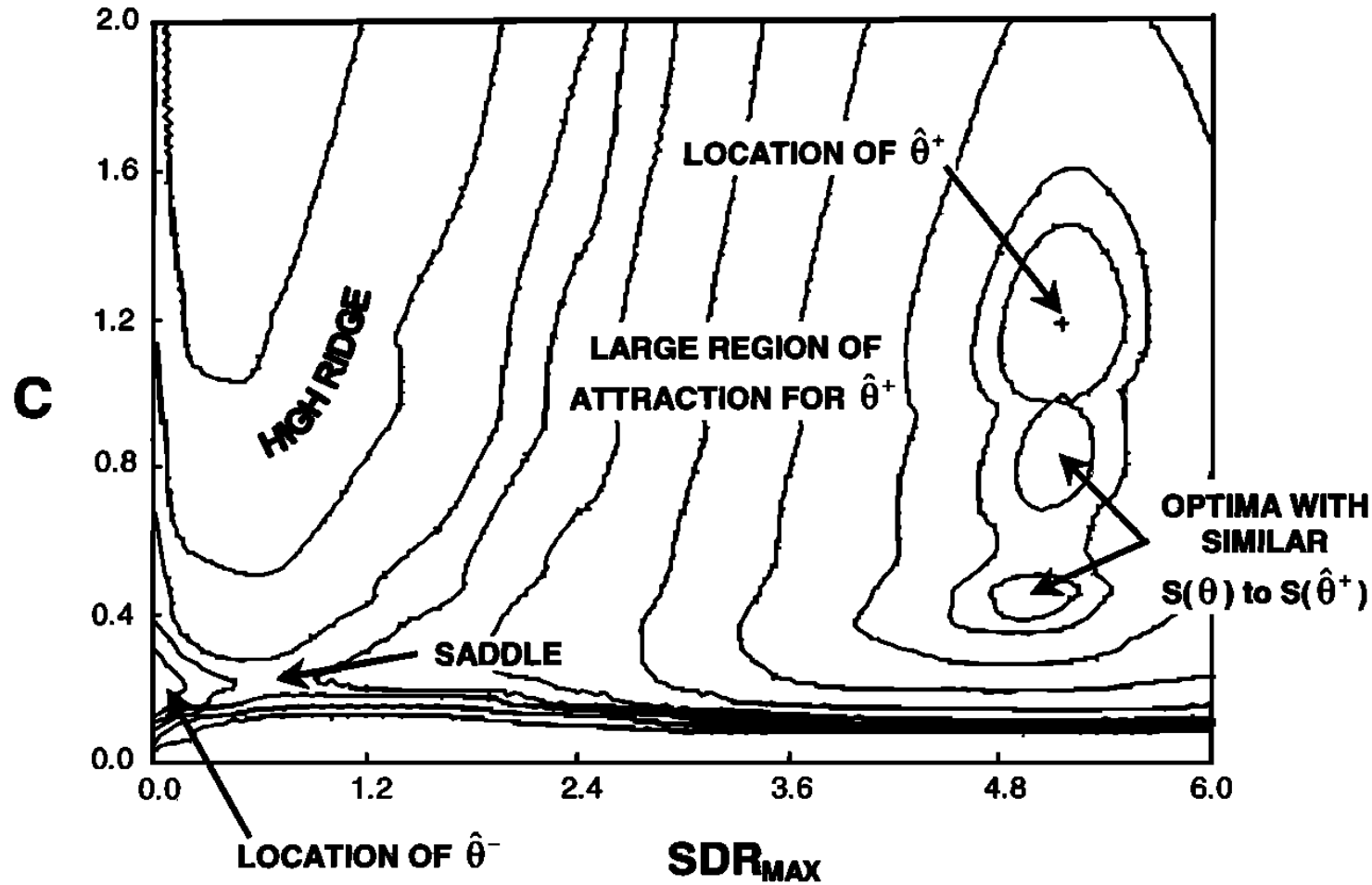

Observations

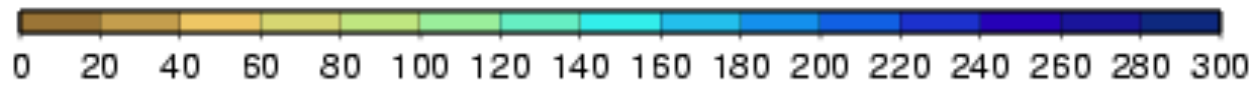
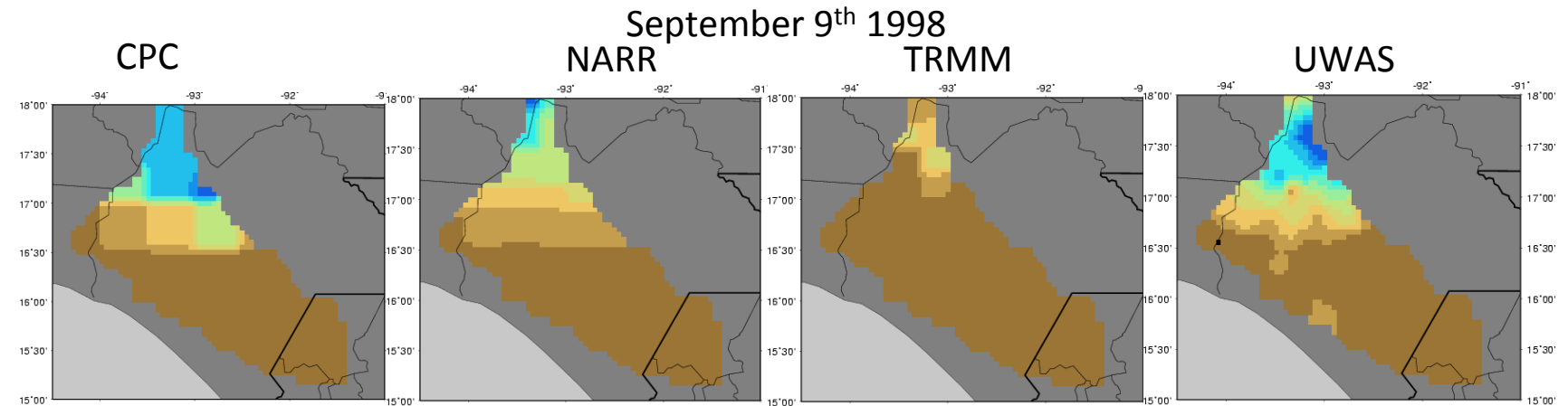
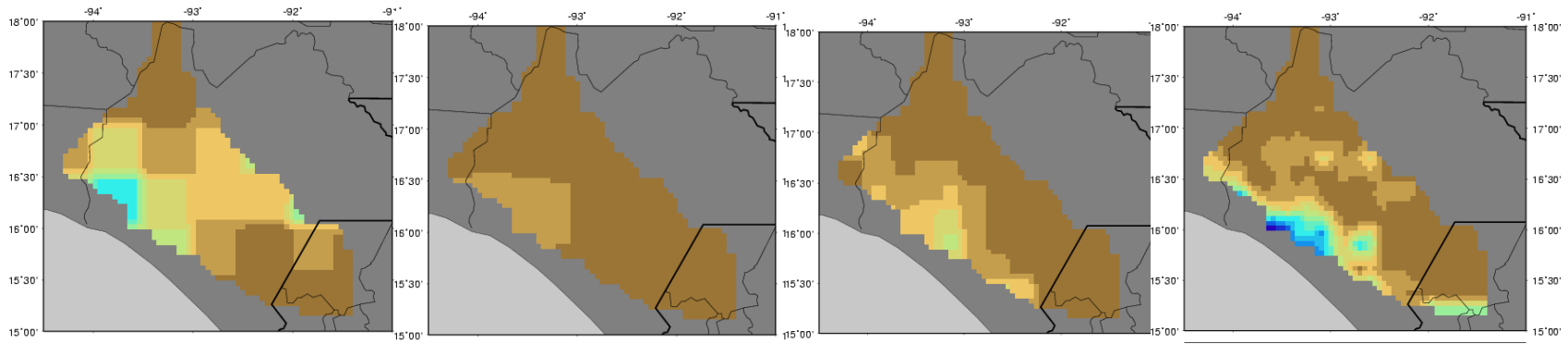

Grijalva River Basin, Mexico

mm

Omissions and Unknowns

Forward Uncertainty Estimation

- Depends on prior assumptions (or distributions) that represent the sources of uncertainty
 - Influenced by selected model structure
 - Initial and boundary conditions
 - Parameter estimation
 - How will be represented (i.e. applied statistical distributions)

Uncertainty Propagation

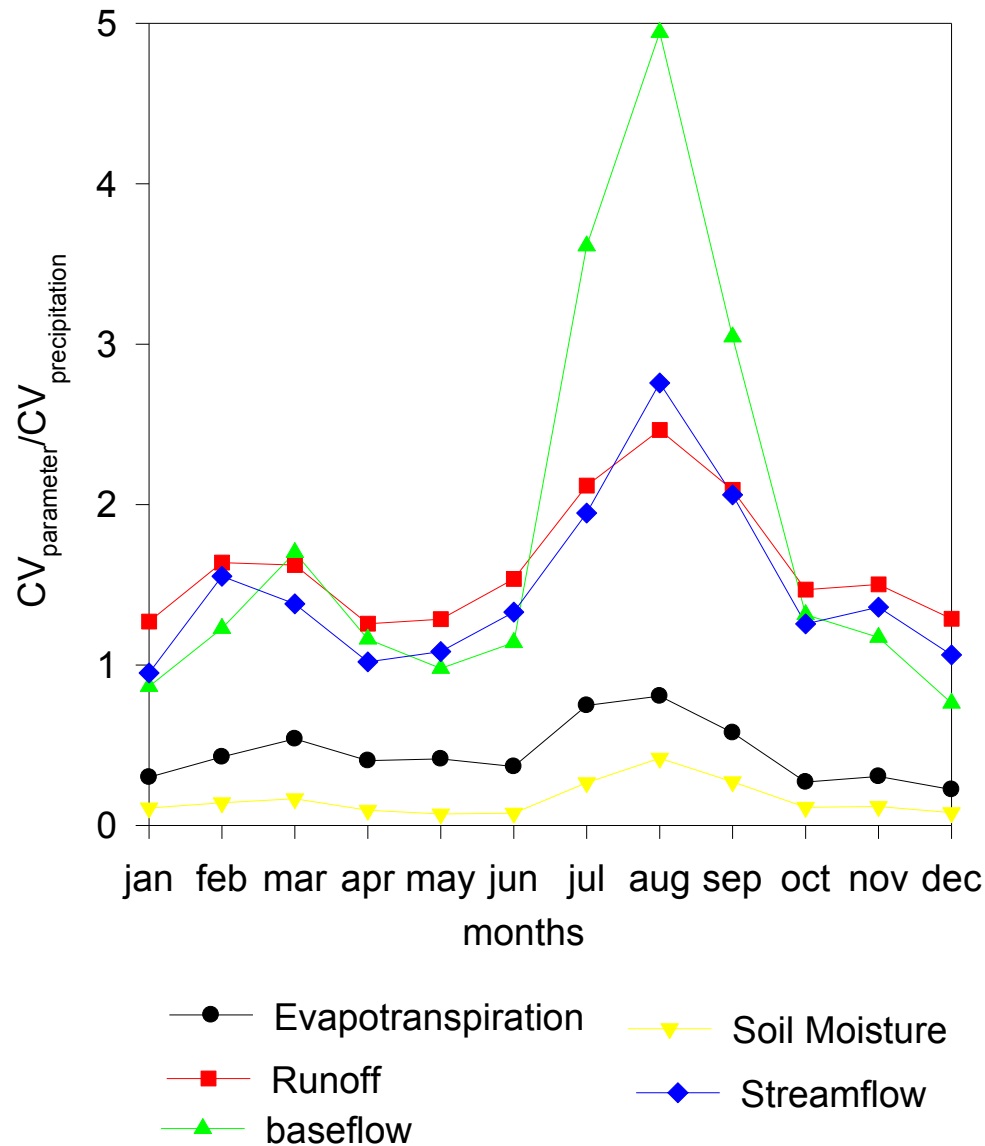

Other Forms of Propagation

Sampling

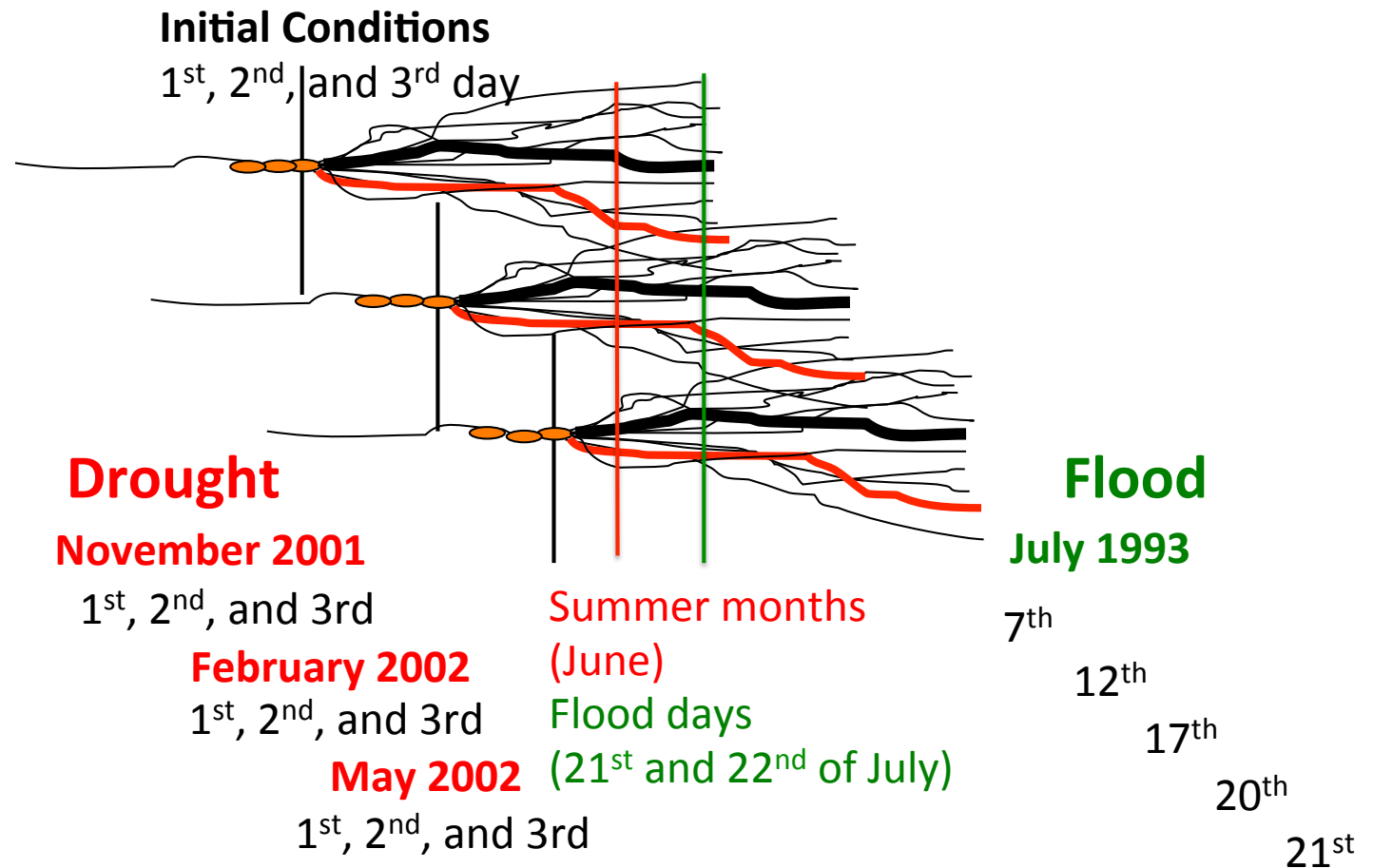
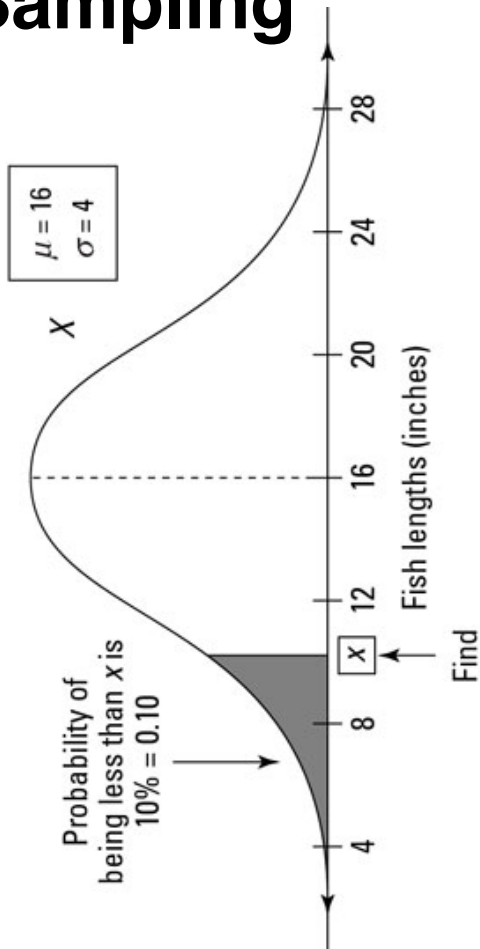

Types of Uncertainty Interval

- Confidence Interval
- Tolerance Interval
- Prediction Interval

Confidence Interval

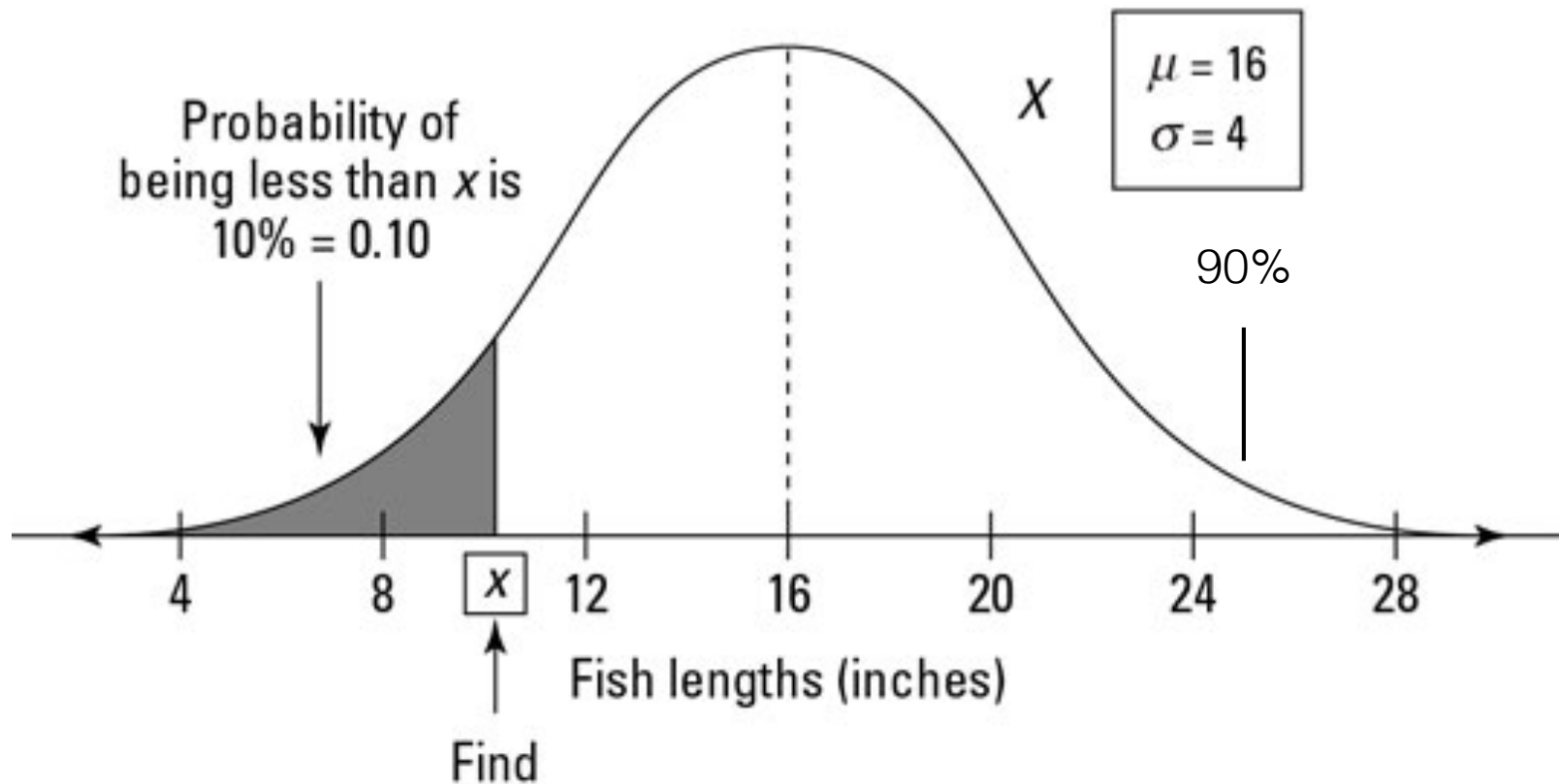

- Used to define the mean estimate with an specified probability (i.e. there is a 70% probability that x is between 10% and 90%)

Tolerance Interval

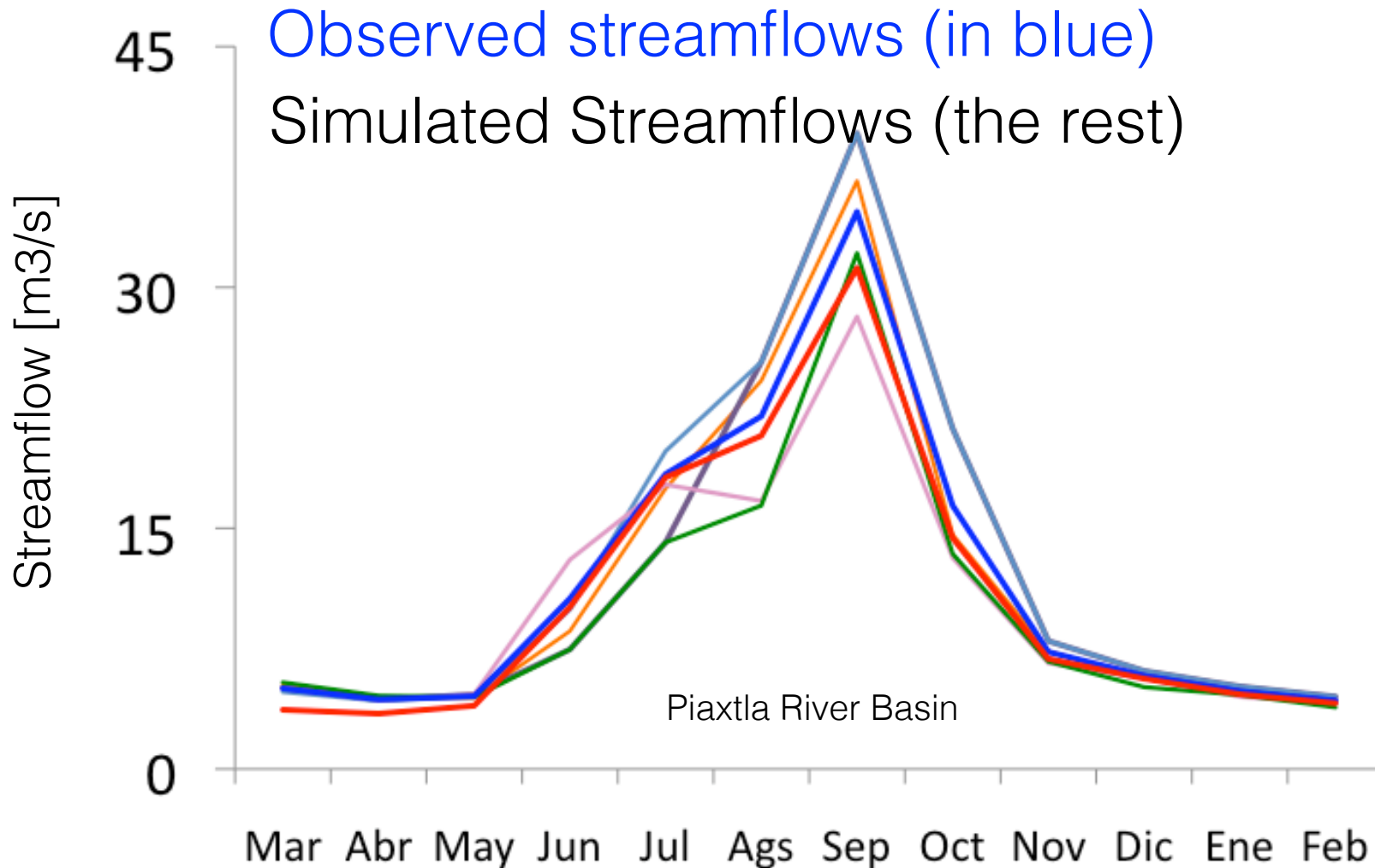

- Proportion of the uncertain model estimates of an observation

Prediction Interval

Observations

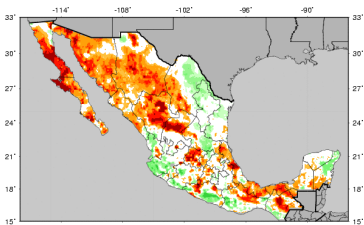

1

Ensemble members

2

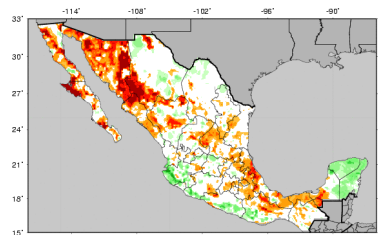
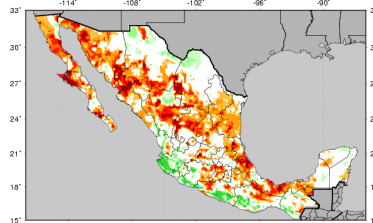
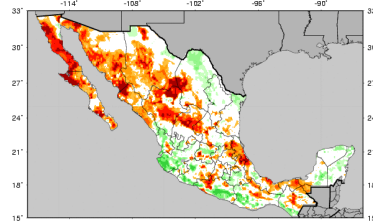

n

Lead-time

1

2

3

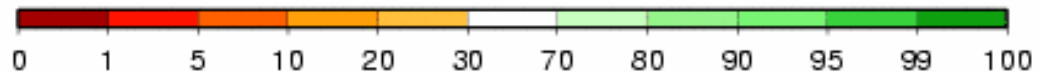
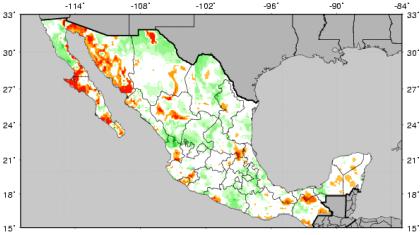
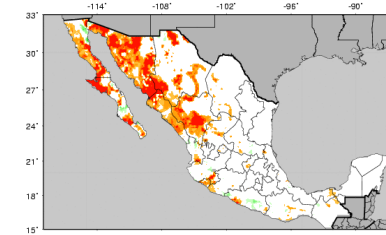
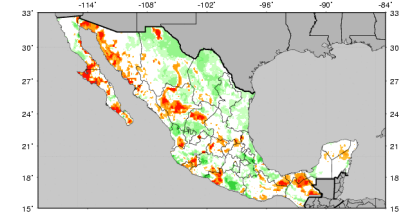
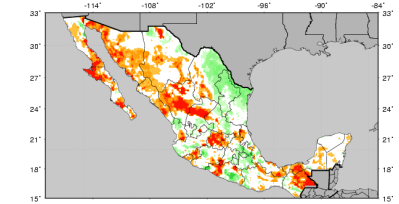
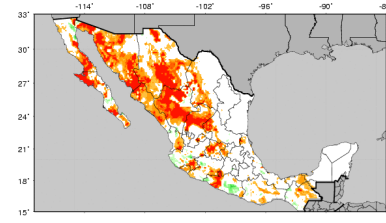
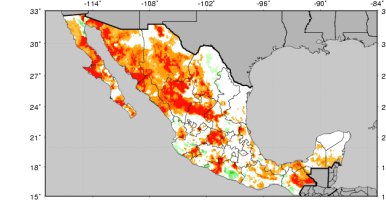

Percentiles of Soil Moisture

- Proportion of the uncertain model estimates for future events

Sensitivity to Parameter Change

Changes in Initial conditions
Precipitation (mm)

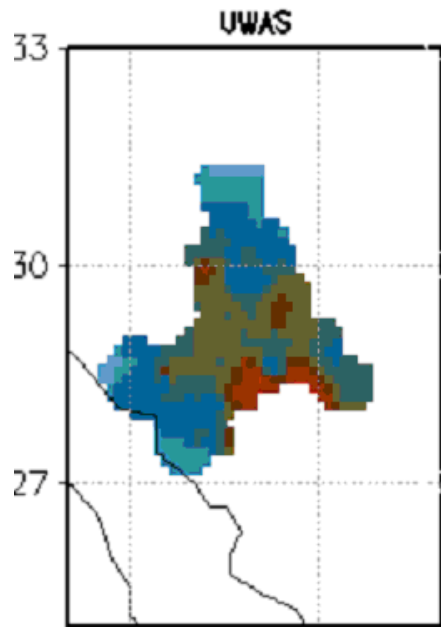

Simulations with changes in model parameters

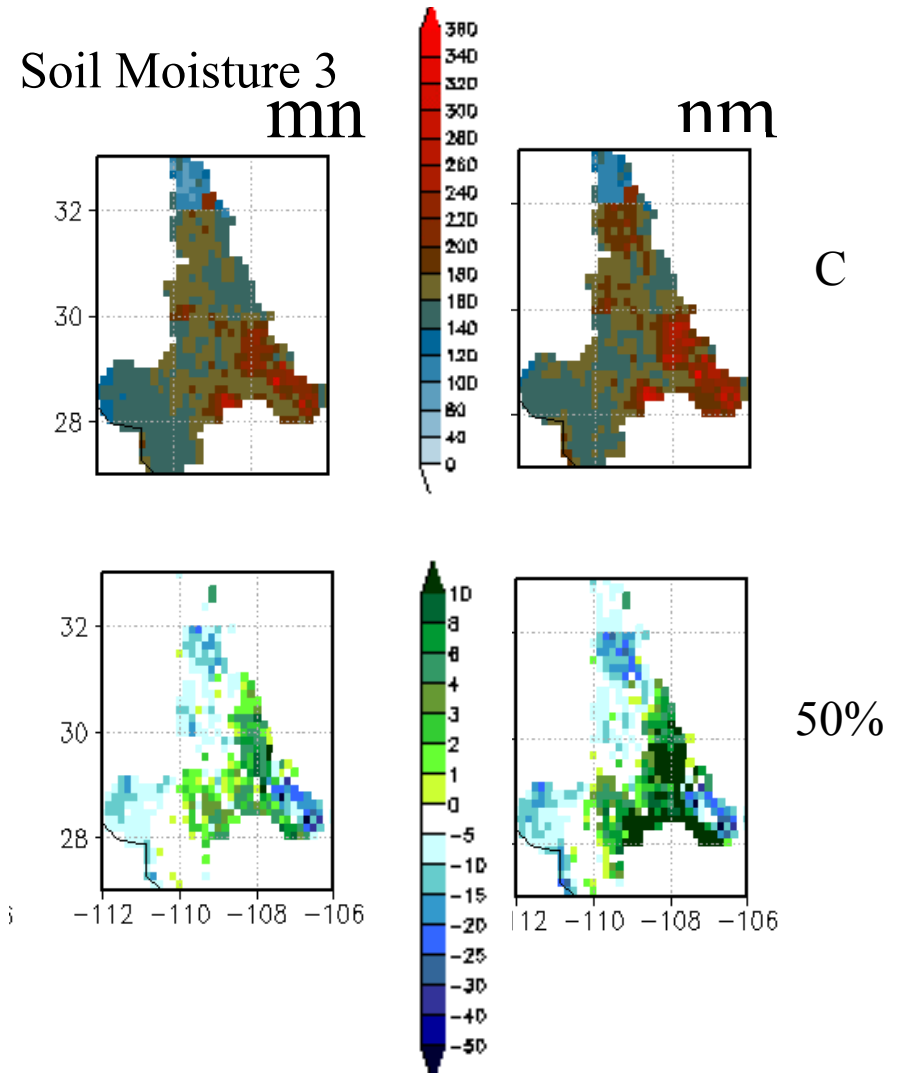

- Higher sensitivity to changes in parameters is reflected in higher uncertainty in simulations

From Forward Uncertainty to Bayesian Statistics

- Depends on prior assumptions (or distributions) that represent the sources of uncertainty
 - Grapples when data and information is constrained
- When observations are available and can be used to condition the uncertainty (or constrain the uncertainty)
 - However, NOT all the observations are commensurate (i.e. measurements with same names but obtained at different resolutions) and consequently informative in any analysis
- We can treat both parameters and observations as random variables

Bayesian Statistical Methods

Changes in Initial conditions

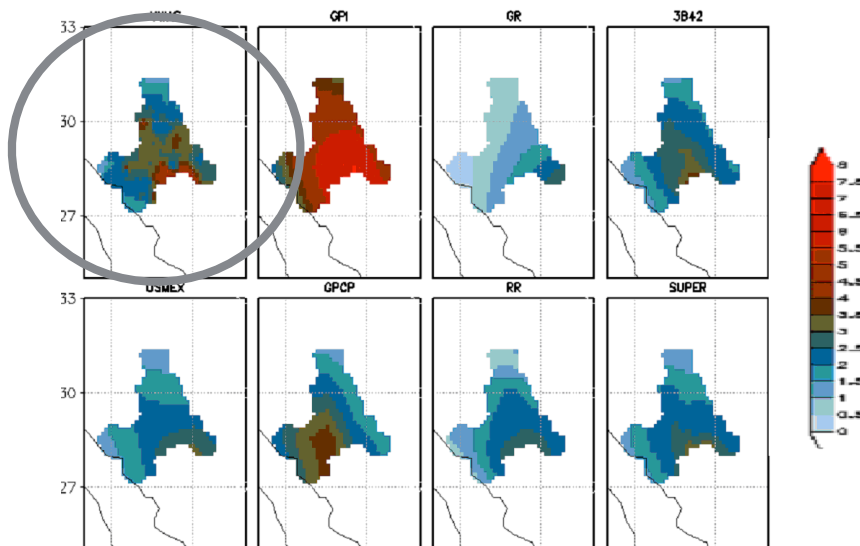

Simulations with changes in model parameters

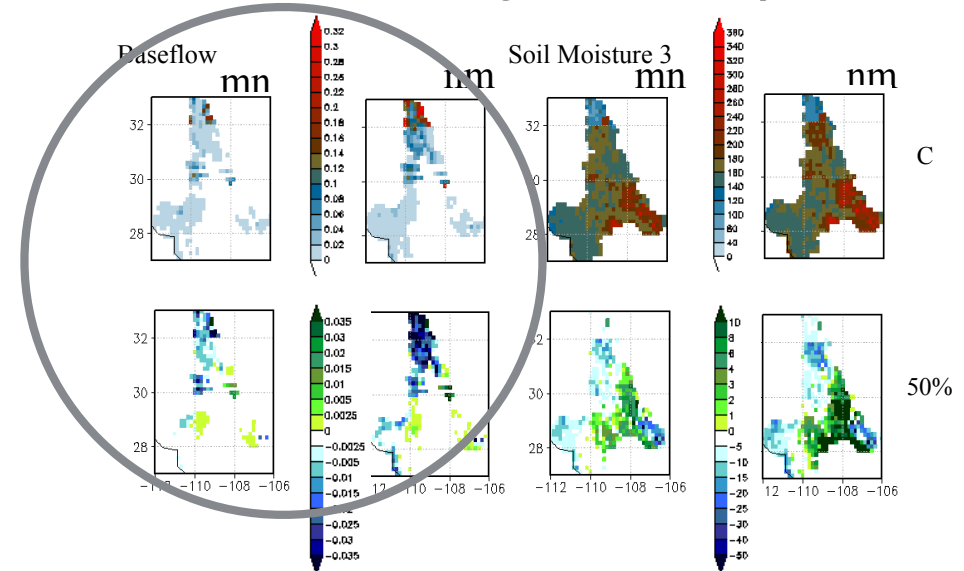

Provides a formalism to combine prior distributions, with a likelihood based on model predictions of the observations to form posterior distributions of parameters (and model errors) to predict the next observation conditional on the model

Bayes Equation

$$L_p(M(\underline{\Theta})|\underline{Y}) = \frac{L_o(M(\underline{\Theta}))L(M(\underline{\Theta})|\underline{Y})}{C}$$

$L_o(M(\underline{\Theta}))$

Prior Likelihood of the model

$L_p(M(\underline{\Theta})|\underline{Y})$

Likelihood calculated for the current evaluation

Global GW and Sea Level Rise

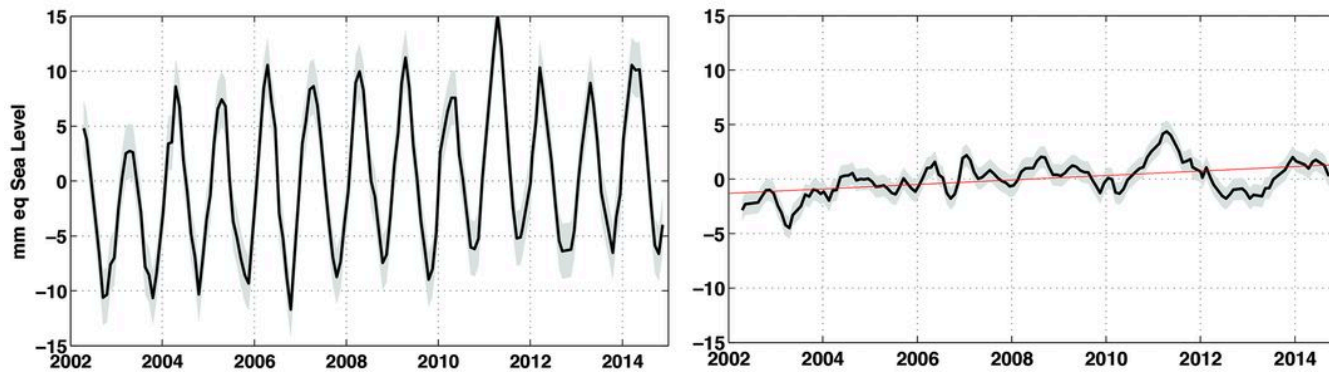
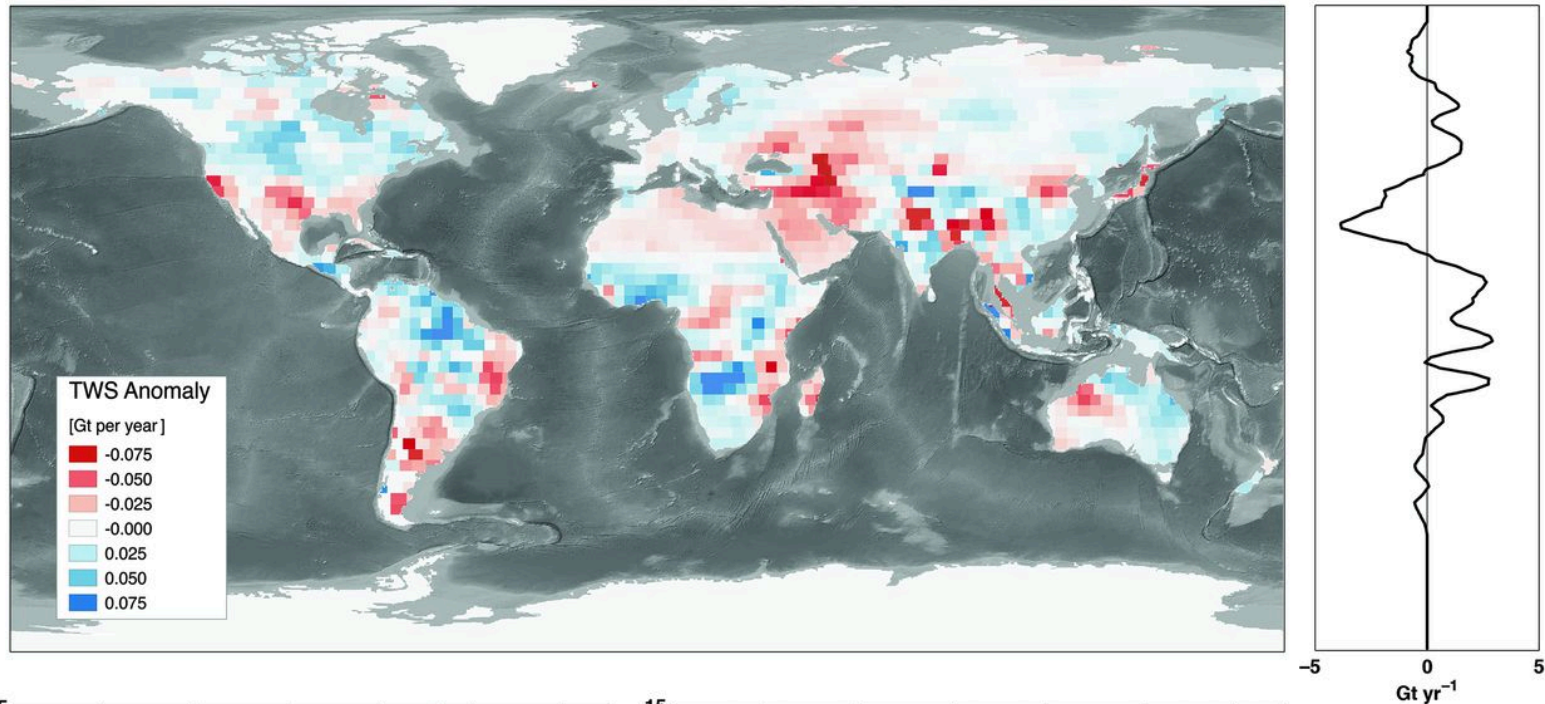

Storage trends partitioned into hydrologic gains and losses

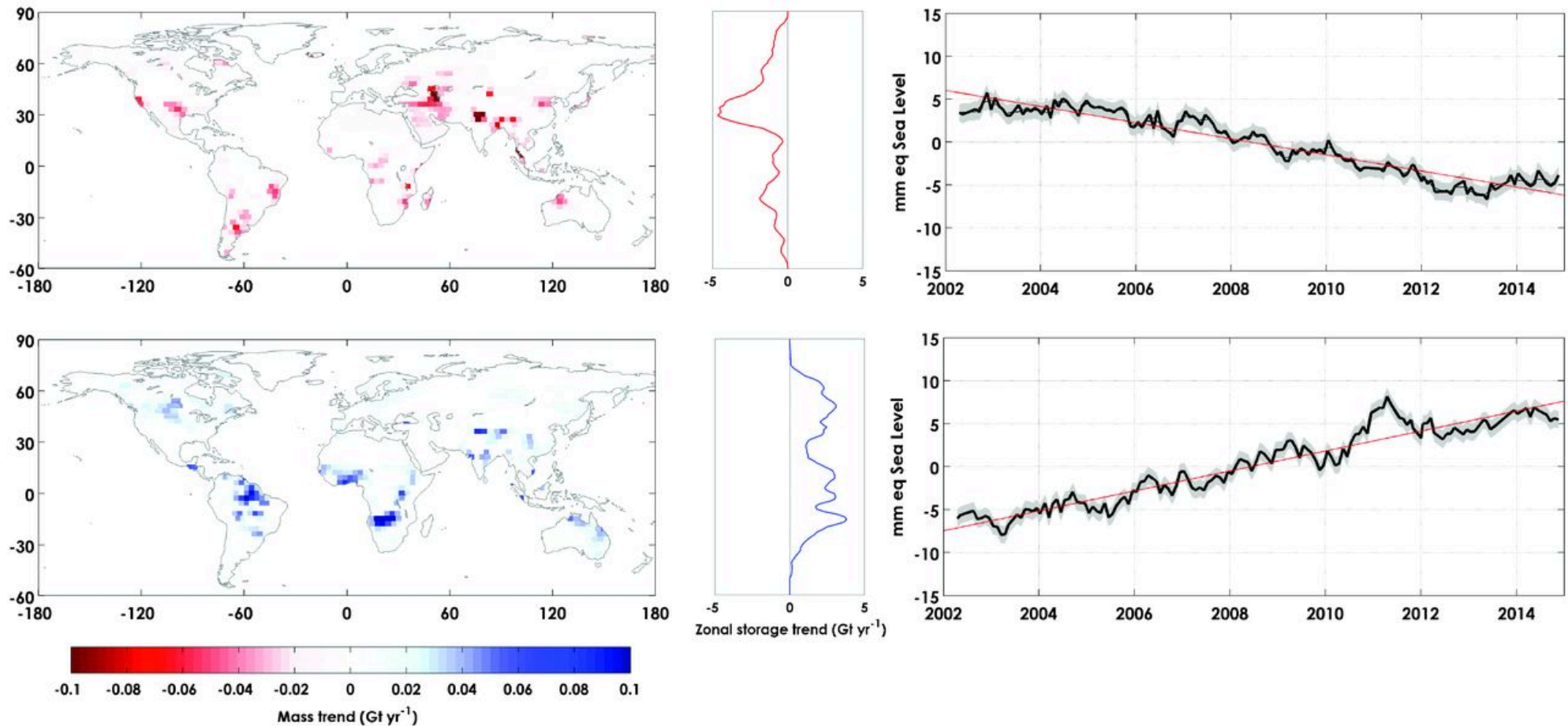

Prediction Interval

Observations

Lead-time

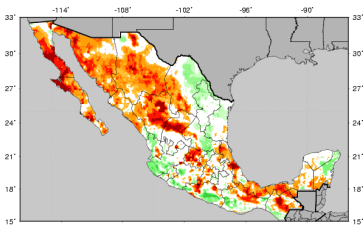

1

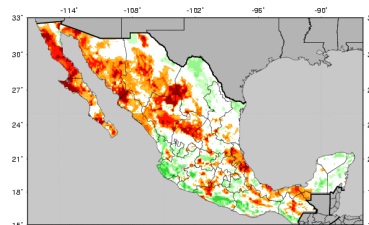

1

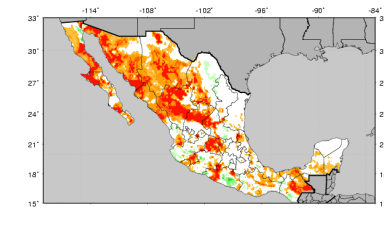

2

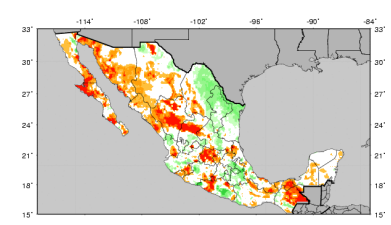

3

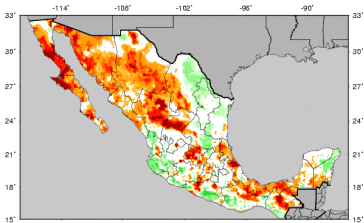

2

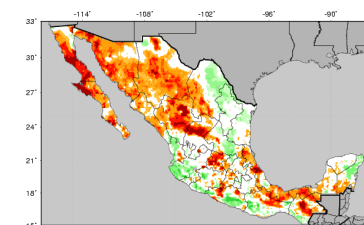
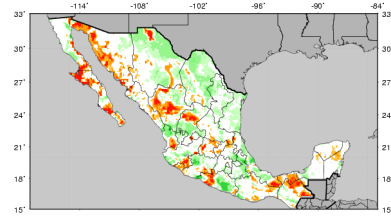
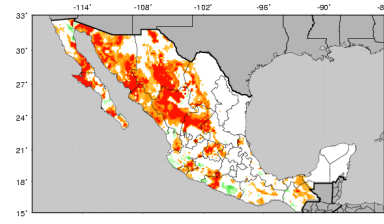
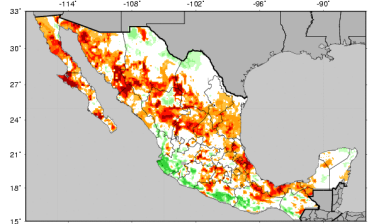

n

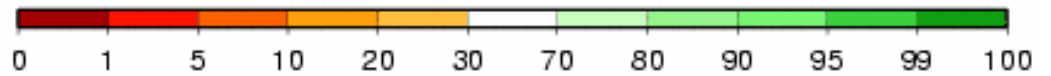
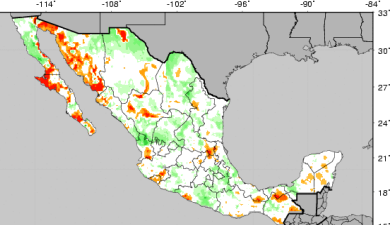
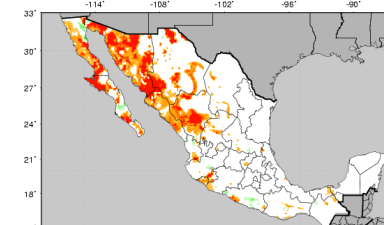
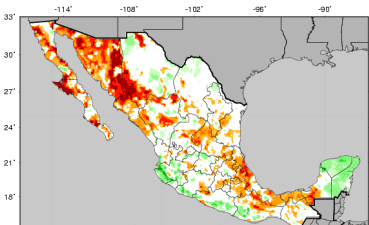

Percentiles of Soil Moisture

Appendix 5

Name: _____

Individual Points: _____

Team: _____

Team Points: _____

Total: _____

NRES/METR/BSEN 479/879

Spring 2016

Assignment No. 1

Data Science

Due: Thursday, February 11TH

Educational Objectives:

By completing this exercise students will better understand:

- » Differences among available climatological data (format and origin)
- » How to find and download data from different sources and with different formats
- » How to visualize and process climatologic data
- » The use of a LINUX/UNIX operative system
- » How and when to apply different forms of data-access, -visualization, and -processing

Procedures:

Each student will be provided with a domain in the US.

- G1: Pacific Northwest, Judson
- G2: Southern California, Chloe
- G3: Eastern Nebraska, Penny
- G4: Southeast US, Alexis
- G5: Northeast US, Dennis
- G6: Western Nebraska, Alessandro
- G7: Northern Texas, Liangzi
- G8: Northern NE, Vasu
- G9: Southern NE, Anduaem
- G10: Central NE, Meetpal

Each individual will do the following steps, which are tasks to be delivered in your report:

Step 1 Follow procedures described in Lab 2 slides.

Step 2 Download climatological data for one (or if you want more) station (s) in your domain.

- » Identify or develop the metadata.
 - ▶ Exact location
 - ▶ Time frequency collection
 - ▶ Timespan
 - ▶ Instrument(s') characteristics
 - ▶ Data network
 - ▶ Other information

- Step 3 Retrieve the grid-data from the Livneh et al (2015) dataset that corresponds to your climatological station
- Step 4 Retrieve the grid-data from the CMAP dataset that corresponds to your climatological station
- Step 5 Plot the time the spatial distribution of precipitation for a particular time (reproduce figures in slides 39-41 in Lab 2 presentation)
- Step 6 Plot the time series of the historical (or climatological) daily and monthly precipitation for a **33-year time span (1980-2013) when is possible**
- Step 7 Estimate the anomalies of precipitation and plot the daily time series (from 1980-2013)
- Step 8 Coordinate with at least three of your peers to discuss your results.
- Step 9 This step is optional. Estimate the trend of anomalies of precipitation.

About individual data

Make sure you provide access to your data to everybody. This means that you must have the same arrangement of subdirectories and file name and structure.

DIRECTORIES AND SUBDIRECTORIES

/work/nres879/HYDROCLIM/LAB2/DATA
/work/nres879/HYDROCLIM/LAB2/PLOT
/work/nres879/HYDROCLIM/SCRIPTS/LAB2

FOR DATA

G1.CLI.M.7913 MONTHLY CLIMATOLOGY FOR Pacific Northwest from 1979 to 2013
G1.CLI.D.7913 DAILY CLIMATOLOGY FOR Pacific Northwest from 1979 to 2013
G1.ANO.D.7913 DAILY ANOMALIES FOR Pacific Northwest from 1979 to 2013
G1.TRE.M.7913 TREND ANALYSES BASED ON MONTHLY DATA
G1.TRE.D.7913 TREND ANALYSES BASED ON DAILY DATA

FOR PLOTS

P.G1.CLI.M.7913
.
.
.
P.G1.TRE.D.7913

REPORT

Your report is individual, however, you can work in group to make sure your understanding, approach, and results are coherent.

Deliverables:

(A) Steps 1-8 (scripts, plots and data). In the report I expect to see plots but I will see scripts, data, and plots in the subdirectories. Certainly scripts will be practically the same as those provided (in this case by Carlos Carrillo-Cruz) but I expect to see them modified for your specific domain.

(B) Make a short narrative about your results: (1) why they are different, (2) what is their value for water and agricultural resources assessments, and (3) what are your thoughts about the possible sources of uncertainty.

(C) Make a short narrative based on the comparison of your results with respect to AT LEAST results from three of your peers. I expect to see the development of a possible hypothesis based on the spatiotemporal contexts you are working. Use spatial elements such as domain and resolution, as well as temporal ones such as frequency and timespan.

(D) Briefly describe how would you improve Lab 2 and this Home Work. Also, answer the a questionnaire that will be sent later this week.

Domain in US: G9: Southern NE

Meta Data of Station

For the Southern NE domain, WILSONVILLE Station was chosen for the analysis and below are the meta data for this station:

Source of data:

<http://www.ncdc.noaa.gov/cdo-web/datasets/GHCND/stations/GHCND:USC00259325/detail>

STATION DETAILS	
Name	WILSONVILLE, NE US
Network: ID	GHCND:USC00259325
Latitude/Longitude	40.1119°, -100.1047°
Elevation	701 m
PERIOD OF RECORD	
Start Date ¹	1894-11-01
End Date ¹	2016-02-03
Data Coverage ²	78%

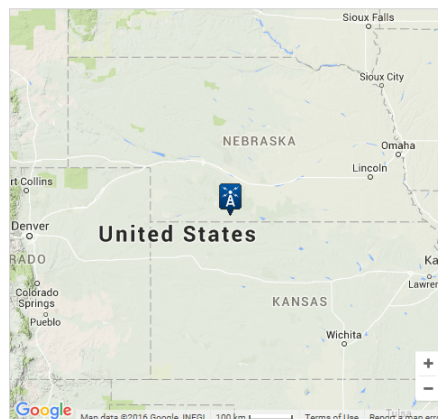

Equipment History (Precipitation)

EQUIPMENT	FREQUENCY	OBS. TIME	BEGIN DATE	END DATE
Standard Rain Gage	DAILY	0700	2015-01-01	Present
Standard Rain Gage	DAILY	0700	2012-02-10	2015-01-01
Standard Rain Gage	DAILY	0700	2002-11-05	2012-02-10
Standard Rain Gage	DAILY	0700	2001-07-20	2002-11-05
Standard Rain Gage	DAILY	0700	1987-09-18	2001-07-20
Unknown	DAILY	0700	1954-03-01	1987-09-18
Unknown	DAILY	0700	1948-06-01	1954-03-01

Latitude Longitude History

LATITUDE	LONGITUDE	PRECISION	BEGIN DATE ¹	END DATE ¹
40.1119	-100.1047	DDddd	2015-01-01	Present
40.1119	-100.1047	DDMMSS	2007-07-16	2015-01-01
40.11222	-100.10444	DDMMSS	2001-07-20	2007-07-16
40.11222	-100.10444	DDMMSS	1996-09-01	2001-07-20
40.1	-100.1	DDMM	1976-12-01	1996-09-01
40.11667	-100.11667	DDMM	1948-06-01	1976-12-01

More description on the station history can be found at:

<http://www.ncdc.noaa.gov/cdo-web/datasets/GHCND/stations/GHCND:USC00259325/detail>

Acquiring Gridded Datasets

Livneh precipitation data set corresponding to the WILSONVILLE station i.e. Latitude 40 and Longitude 259.9 was extracted for each year using [getstationlivneh2.m](#) matlab code provided by Carlos and concatenated into a 1980-2010 time. The same procedure was followed to retrieve CMAP monthly precipitation data for the station location.

Graphical Comparison

Climatology

Figure 1 shows the climatology of daily precipitation over Wilsonville Station located at the Southern Nebraska area. The area has wet (rainy) season from April to September and a shorter wet period following a relatively drier period around October.

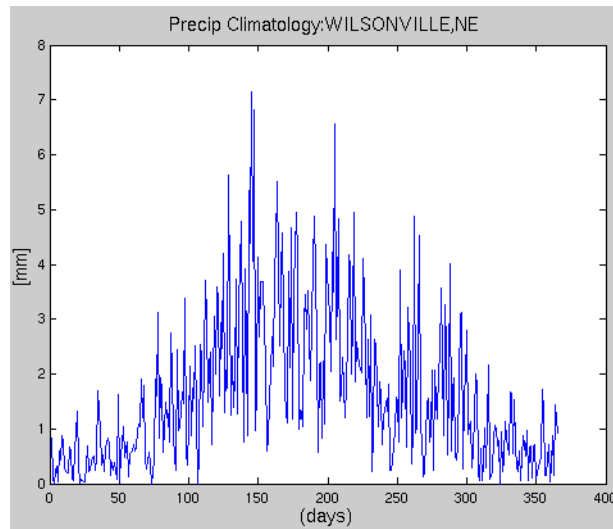

Figure 1: Daily Precipitation Climatology over WILSONVILLE Station; Southern NE

Spatial Comparison: Observation vs Gridded Data

Figures 2a to 2c below show annual precipitation in mm/day over the US from CMAP Data and Livneh respectively for the year 2000 (chosen randomly). The Livneh Dataset shows annual precipitation amounts that go a little more than 6.5 mm/day while the CMAP datasets shows lower spatial precipitation distribution with 2.5mm/day being the highest over the region. The differences are significant over the Eastern part that is climatologically wet. From the analysis of the time series (shown latter), it can be deduced that CMAP significantly underestimates annual precipitation during 2000 period. Figure 2b however shows that the representation of spatial pattern of precipitation is improved while 30 years climatology is plotted.

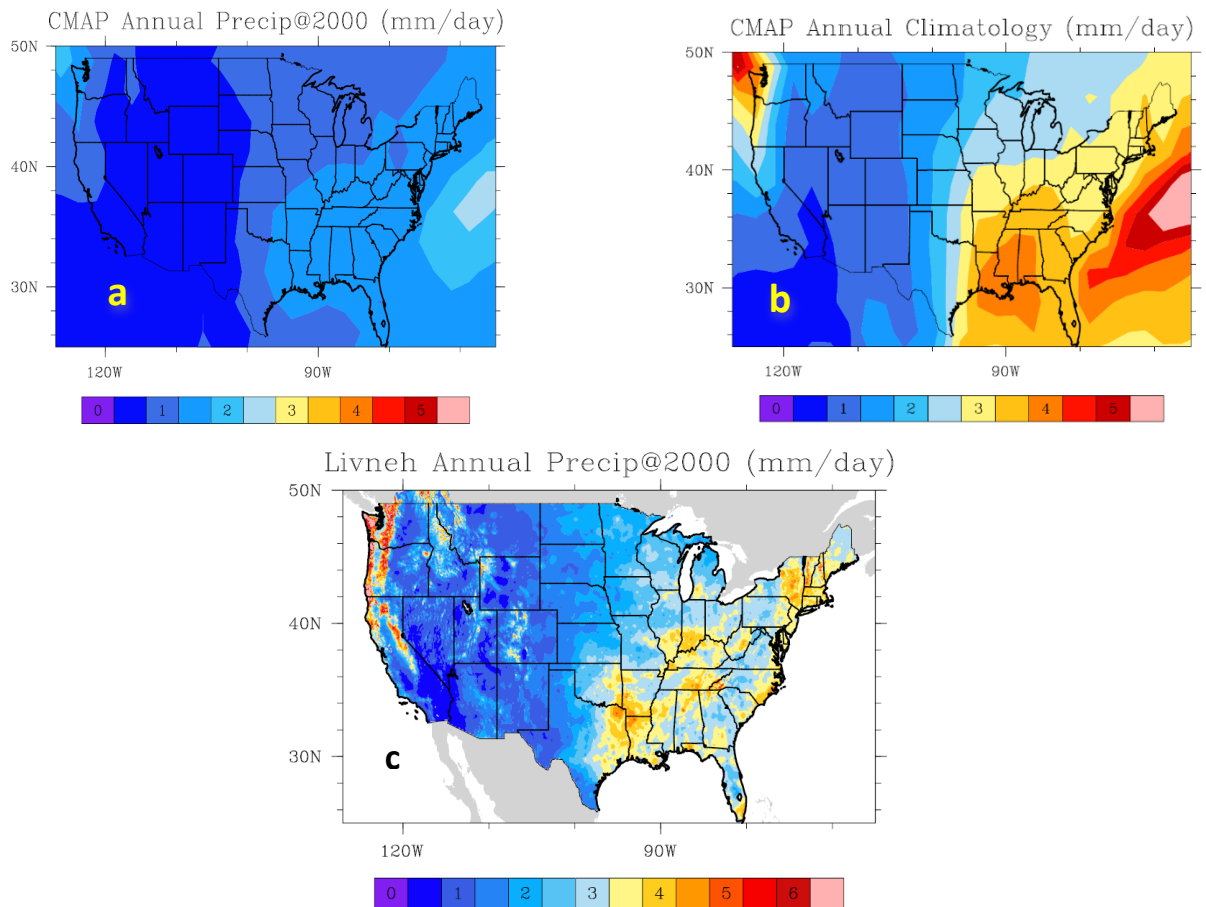

Figure 2. Spatial Distribution of Annual precipitation on year 2000 (a and c) and yearly climatology (b)

Time Series Analysis

The period from 1981-2010 was chosen for time series analysis as it is a common period where data is available for the three datasets. For Daily data Livenheh dataset was plotted with Station while for monthly all three were plotted together.

From the daily plot, one can see that Livneh Dataset has consistently underestimated observations throughout the analysis period. Extreme events in particular are poorly captured. Though plot is not detailed enough, it is can be said that, the agreement between observation and Livneh is better over lower values of precipitation which is more visible in the Daily scatter plot (left). On monthly basis, both gridded products underestimate monthly total precipitation and the disagreement is pronounced over higher values. However, the plot clearly indicate that Livneh dataset has better agreement with station observation than CMAP. From the scatter plot (right), we can see that data points are more clustered towards the 1:1 line for Livneh Vs Station and for the CMAP vs Station, there is better agreement at lower values and CMAP significantly underestimates as values grow higher.

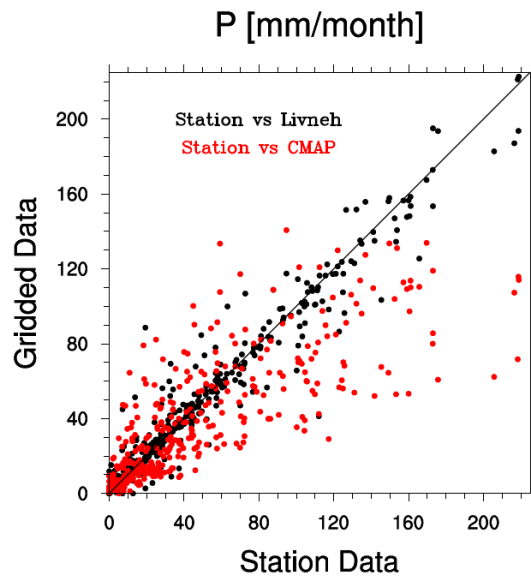
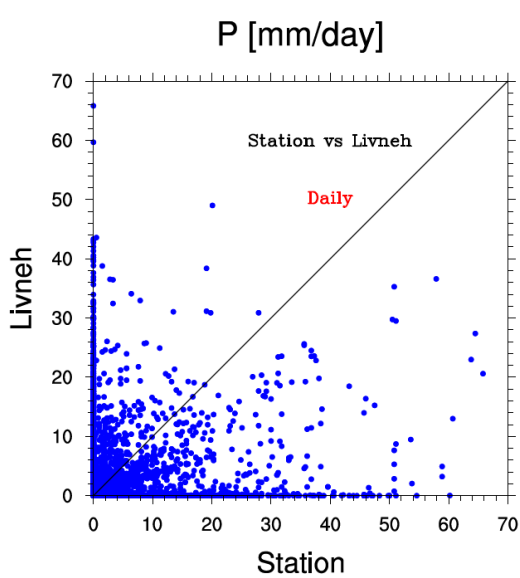
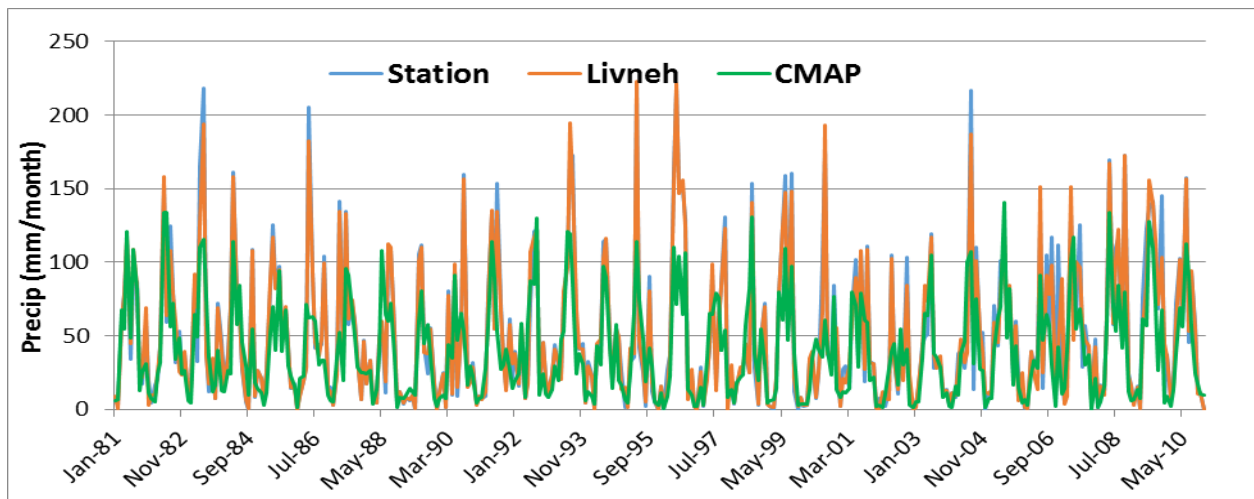
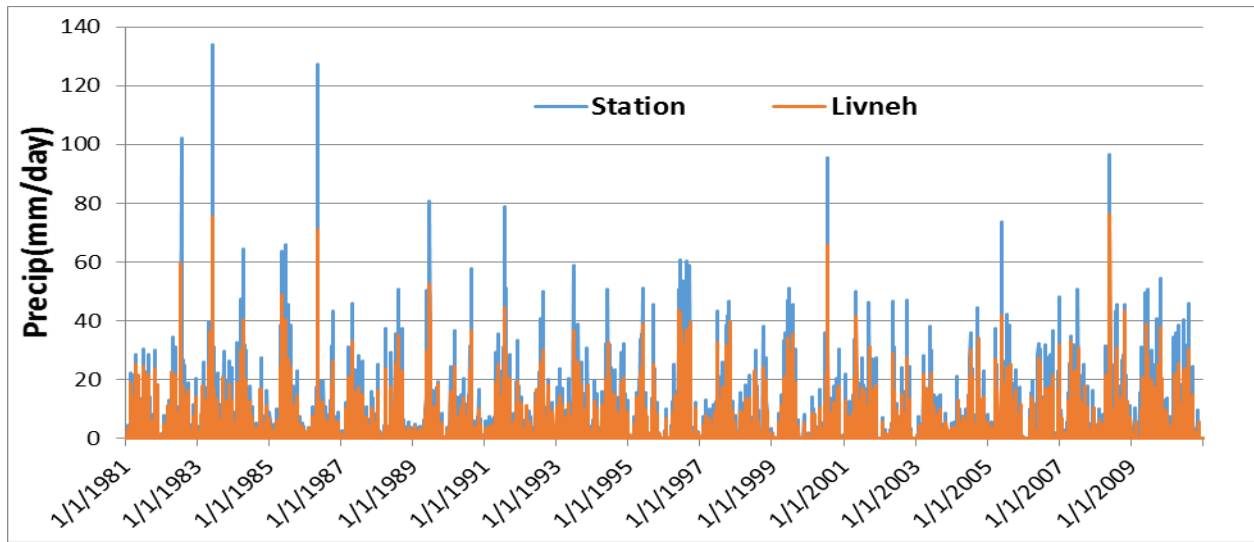

Figure 3: Time series of daily data (top), monthly (middle) and scatter plot of Daily (bottom left) and monthly (bottom right) precipitation for the period 1981-2010

Anomalies were calculate for all the three datasets both on daily and monthly time scales using daily and monthly precipitation and 30 years mean to see the temporal distribution of anomalously wet and dry events. From the anomaly plots, it can be seen that there are several anomalously wet months under all the datasets throughout the analysis period and it can also be seen that they stand out when compared with anomalously dry events. However, there isn't any significant trend in anomalies over the 30 years of analysis period. *Because of the size of data, only monthly anomalies are shown here.*

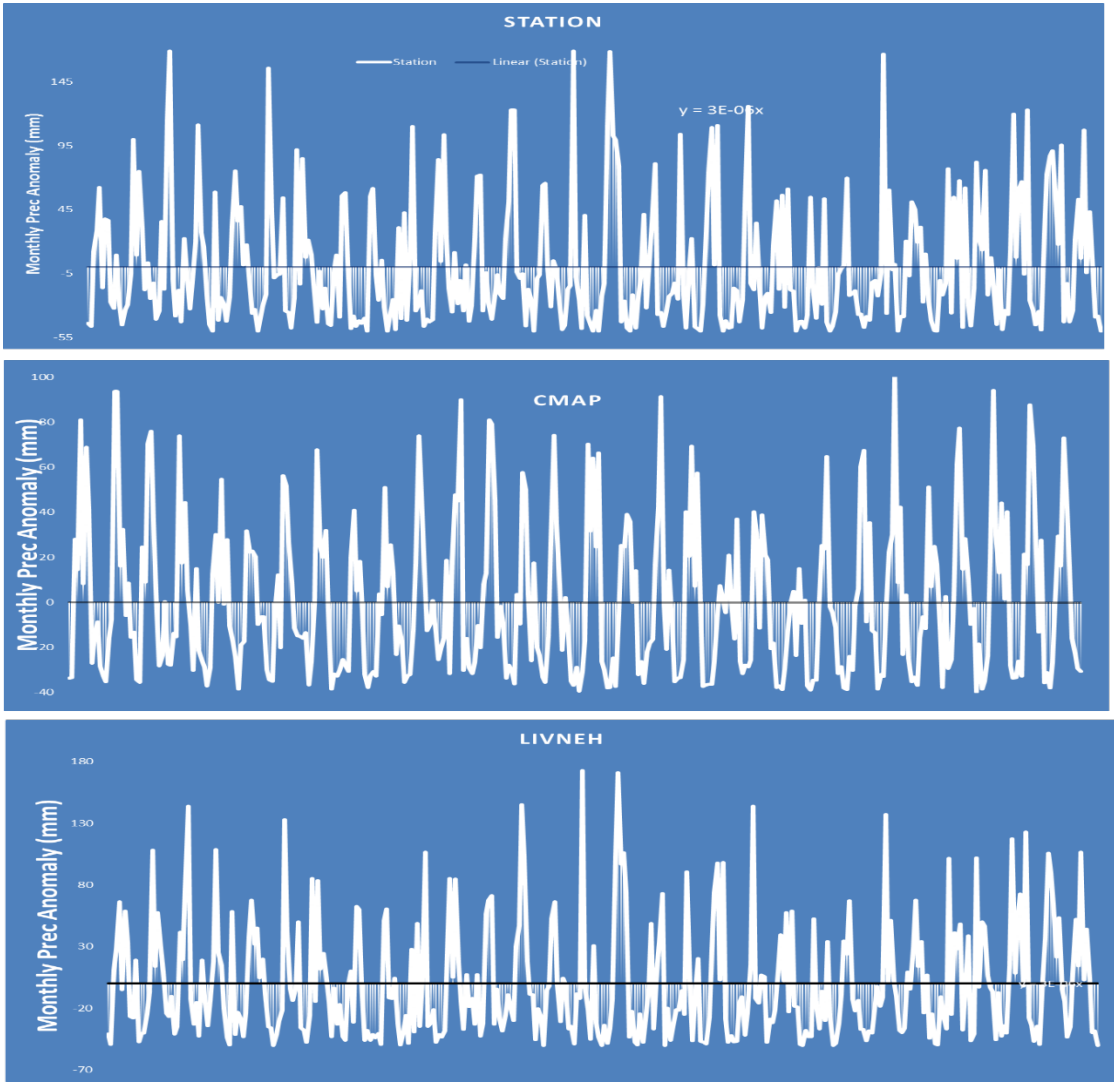

Figure 4. Monthly precipitation anomaly

Further Discussion

The comparison of the station data with two other gridded products above indicated that the gridded datasets consistently underestimate station observations. The same was found to be true for other locations analyzed by the class (at least those I have looked at). However, the degree to which the products underestimate the station observation vary from location to location specially the case with CMAP where it significantly underestimates precipitation in Southern NE which is case.

Though the specific cause of the mismatch between the station and the gridded products need a detailed assessment, the following can be possible causes:

The area of representation: the stations data are collected at a specific location and are representative of a certain locality (even that has its own uncertainties). The gridded products on the other hand represent a grid with a varying physical characteristics that will have an impact on precipitation distribution. The resulting gridded product will be an average? representation of these conditions and when compared with a point measurement, there will obviously be a different. One of the key example here will be the impact of topography where even two station only few kilometers apart can have a significantly differing precipitation as a result of their differences in altitude.

In addition, the method employed to develop these products have its own impact. Some products have lots of station observations merged with satellites while others are purely satellite based; some take into consideration the impact of topography while others don't and so on.

Usability of such products

- Such kinds of gridded products are ideal to decision makers at higher level as it given a comparative picture of different climate driven hazards like drought over an entire country or the globe and guide their decision making. They can be used to identify vulnerable hot spots and accordingly prioritize mitigation measures and resources.
- In additions, ones the methodology of developing such datasets are well tested and put in place, they can be used as an important source of information for detecting climate phenomena like drought ahead of time, unlike station based observations which take longer period of time and resources to collect, archive, process and utilize.
- Such products are also ideal (handy) for evaluating/calibrating/bias correcting different climate model outputs.

Name: _____

Individual Points: _____

Team Points: _____

Team: _____

Total: _____

NRES/METR/BSEN 479/879

Spring 2016

Assignment No. 2

Project Outline/Concept Paper

Due: Thursday, February 25th

Educational Objectives:

By completing this exercise students will better understand how to develop a concept paper/outline. Please make sure you address the following aspects:

- » Develop a clear goal of your project
- » Name at least 5 elements that evidence the gap of information in your topic
- » Formulate a scientific question based on the point above
- » Develop clear objective(s)
- » List your hypothesis(es)
- » Describe (in bullets) a preliminary methodology
- » You can strength the elements above with maximum two figures

Support information:

I am uploading two additional documents (1) "Some Ideas on Writing a Successful Proposal" and (2) "Type your own concept paper".

REPORT

Your report is individual and requires a two-pages maximum document.

NRES- 879 HYDROCLIMATOLOGY

CONCEPT PAPER/PROJECT OUTLINE

EVALUATION OF LAND SURFACE HYDROLOGY MODEL AT FIELD SCALE USING IN-SITU MEASUREMENTS OF LAND-SURFACE CHARACTERISTICS

1. Overall Goal and Objectives

For studying water fluxes and water budget at field scale, the parameterization of the microscale variability of the most important land surface characteristics (Leaf area index, stomatal conductance etc.) is particularly important. In this study, we are trying to evaluate the accuracy, capability and application of land surface hydrology model at field scale.

The objective of this work is, (1) to parameterize the land surface hydrology model using in-situ measured data at field scale, and (2) to compare the output of the parametrized model simulations with measured data.

2. Problem to be addressed

The Land-surface Hydrology models are flexible modeling systems which contains several options for physical parameterizations. Various parameterization schemes for different physical processes are available for the users to apply. This allows the users to easily optimize the configuration of the model for their specific needs, something that makes these modeling system very flexible and suitable in a wide range of applications. At present, to the best of my knowledge, the application of these models at a field scale levels has not been studied. In general, these models uses multi-year averages of land surface characteristics on very large scales and therefore, lack the ability to capture real time vegetation status and land surface conditions at field scale. So it is very important to understand the behavior, accuracy and applications of such models at field scale.

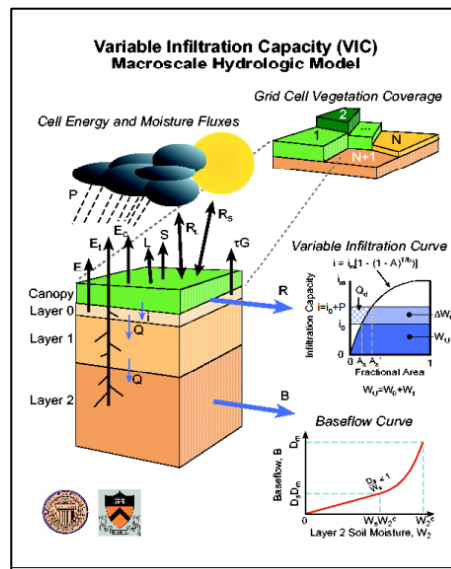

3. Preliminary Methodology

For this study, we are planning to use a land surface hydrology model (most probably variable infiltration capacity VIC model) and parameterize it using field measurements for the 2015 maize growing season in NE. The field used for this study is a 5 acre large field situated at South Central Agricultural Laboratory at Clay Center, NE. Extensive field measured data including weekly LAI, hourly soil moisture content (calculated ET), Plant height, precipitation, soil characteristics, Field capacity, Permanent wilting point and others will be used for this process accordingly. After the parameterization of the model, we will run the model using Livneh data set for the study site and then evaluate the model output in terms of soil moisture, ET, and other fluxes.

4. Potential Impacts/Outcomes/Expected Results

From the particular study we are expecting to see positive or negative performance of the land surface hydrology models at field scale. If we find that these models perform satisfactorily at field scale then there are chances that we can replace the expensive instrumentation that we generally use at field level with this already existing models and global datasets. Obviously, the use of these models would not yield as good results as by the extensive field measurements but one can expect reasonable agreement between them. Even we find some reasonable agreement, we will be able to measure surface characteristics using these models at very small scales and at different time and at places where instrumentation is not possible.

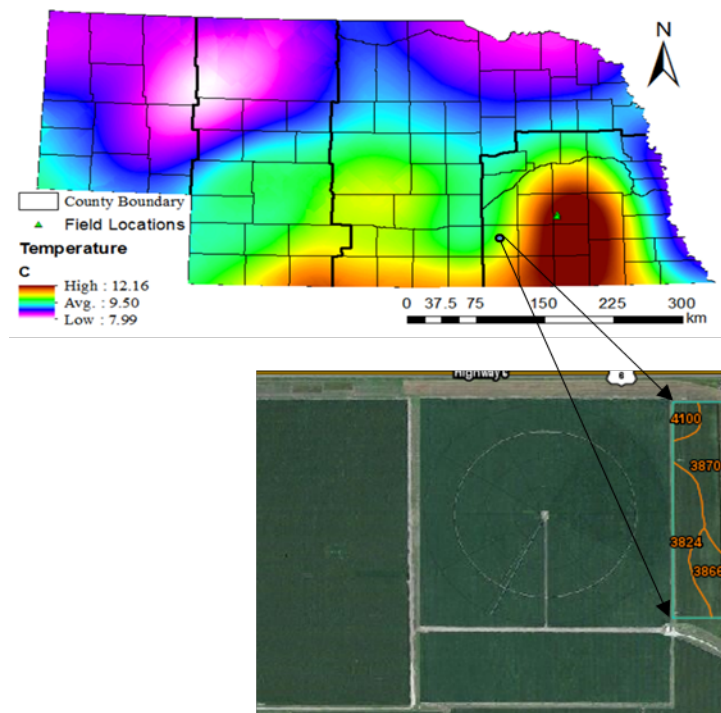

Location of the research field (lower) with temperature variation in the state of Nebraska, USA.

Name: _____

Individual Points: _____

Team: _____

Team Points: _____

Total: _____

NRES/METR/BSEN 479/879

Spring 2016

Assignment No. 3

Data Science

Due: Thursday, March 3rd

Educational Objectives:

By completing this exercise students will better understand:

- » How to aggregate data (spatially and temporally)
- » How to develop time series data
- » Implement the use of basic time series analyses
- » Simple forms to assess causality within water and climate systems

Procedures:

Each student will be provided with a domain in the US.

- G1: Pacific Northwest, Judson
- G2: Southern California, Chloe
- G3: Eastern Nebraska, Penny
- G4: Southeast US, Alexis
- G5: Northeast US, Dennis
- G6: Western Nebraska, Alessandro
- G7: Northern Texas, Liangzi
- G8: Northern NE, Vasu
- G9: Southern NE, Anduaem
- G10: Central NE, Meetpal

Each individual will do the following steps, which are tasks to be delivered in your report:

Steps are described in Lab 3 Activity in Blackboard

About individual data

Make sure you provide access to your data to everybody. This means that you must have the same arrangement of subdirectories and file name and structure.

DIRECTORIES AND SUBDIRECTORIES

/work/nres879/HYDROCLIM/LAB3/DATA

/work/nres879/HYDROCLIM/LAB3/PLOT

/work/nres879/HYDROCLIM/SCRIPTS/LAB3

FOR DATA

Follow the descriptions on the slides

FOR PLOTS
P.G1.TS.M.7913

•
•
•

P.G1..TS.7913

REPORT

Your report is individual, however, you can work in-group to make sure your understanding, approach, and results are coherent.

Deliverables:

- (A) Monthly time series of precipitation for
 - a. Spatial Aggregate of your domain and 4 different points of your selection (preferably close to your location or addressing an specific research interest)
 - (B) Monthly time series of the climatic indices provided in the slides (ENSO, PDO, etc)
 - (C) Correlation analyses between the aggregated-time series and the 4 different points of your selection; correlation between the time series above and the Indices in question
 - (D) Develop the anomalies of precipitation time series. NOTE: Develop the same analyses as in (C)
 - (E) Make a short narrative about your results: (1) why C and D are different,
 - (F) Compare your findings with another member of the group.
- (D) Briefly describe how would you improve Lab 3 and this Home Work. Also, answer the questionnaire that will be sent later this week (NOW will be 2!).

Date: February, 2016

Student: Alessandro Amaranto

1- Introduction & Data Presentation

The purpose of the current assignment was to perform time series analysis and correlation analysis of the precipitation variable, and to get familiar with data preprocessing. The data used are coming from the Livneh dataset, which includes daily precipitation (among the other variables) in the period 1953-2011, gridded to $\frac{1}{16}$ km resolution. The spatial domain goes from Mexico (southern border) to some regions of Canada south of 53° . In this particular case, we choose the spatial domain of North-West Nebraska. Therefore, from the Livneh Dataset, were extracted the precipitation values going from 42° to 43° N, and from 103° to 102° E. Moreover, the analysis was performed on a monthly basis. Therefore, the average precipitation value was computed, and then the cyclostationary mean was removed from the time series. The time series is represented in figure 1.

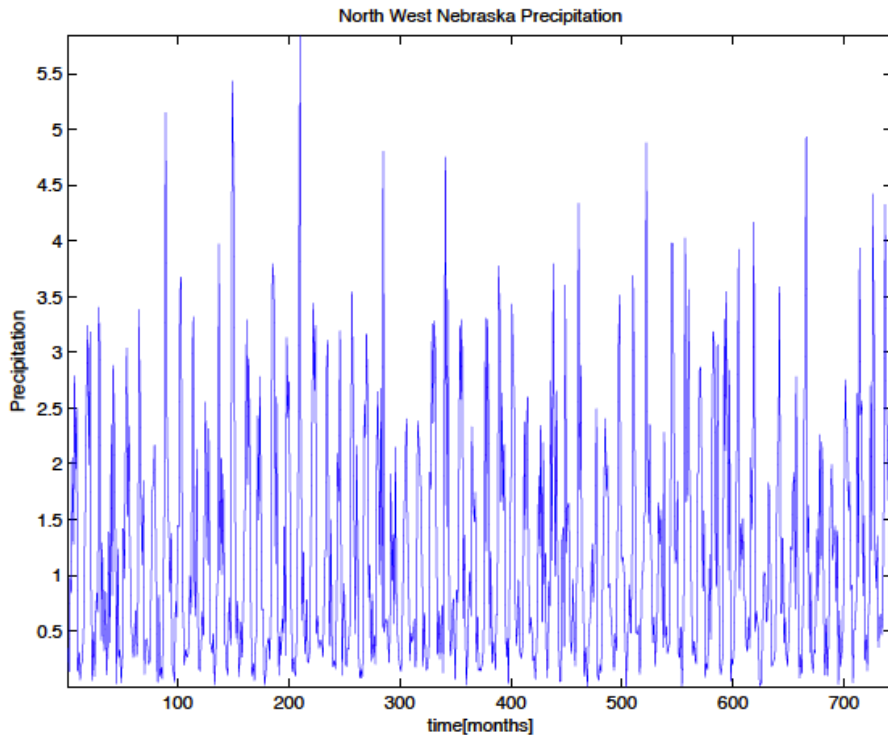

Figure 1: Precipitation Time series of the region of interest

1.1 The selected points in the domain.

In order to perform correlation analysis, four other points were chosen, corresponding to other four regions in the state of Nebraska: Center, North East, North West (different location) and South East. The coordinates of the points, together with their time-series, are represented in table 1 and figure 2.

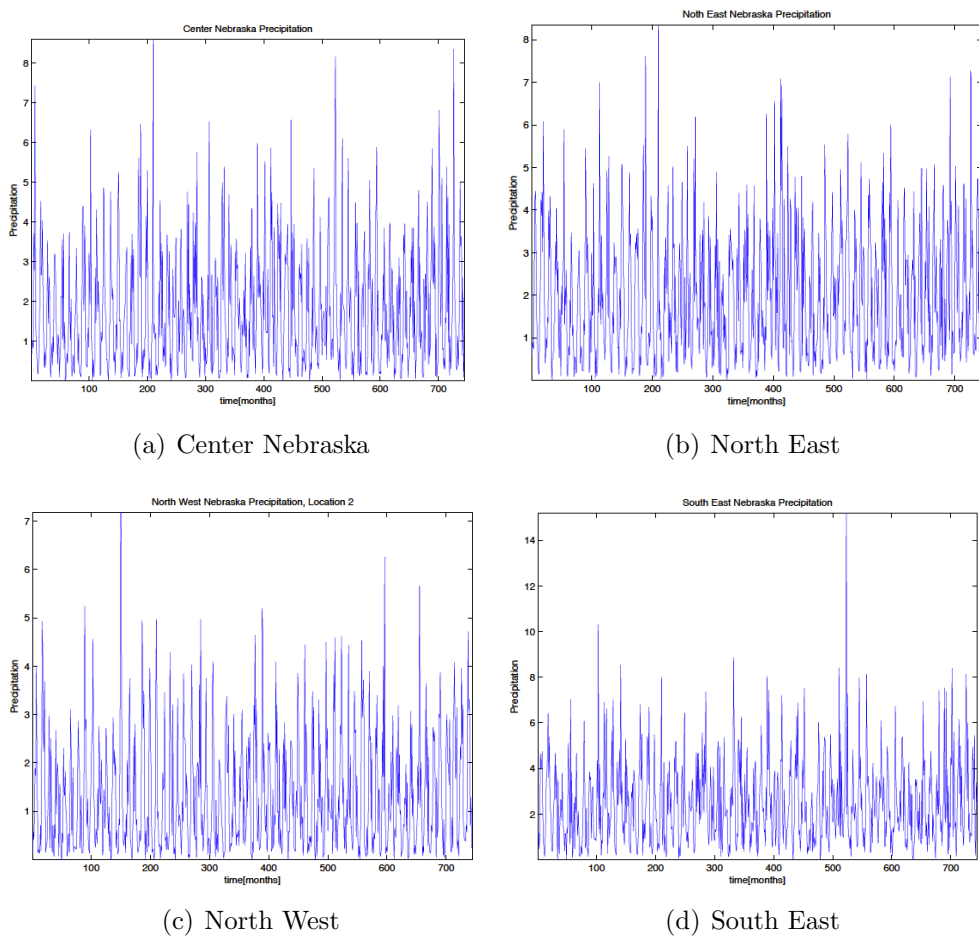

Figure 2: Time series of precipitation value in the other four regions selected for the analysis

ID	Min N	Max N	Min E	Max E
C	40	41	98	99
NE	42	43	96	97
NW2	40	41	96	97
SE	40	41	96	97

Table 1: Coordinates of the other four points in Nebraska

1.2 The Indexes

The correlation analysis was performed also with three climatological indexes, namely the PDO index, the MEI index and El Nino index. The results of the correlation will be presented and discussed in the following sections. Figure 3 represents the time series for the three indexes.

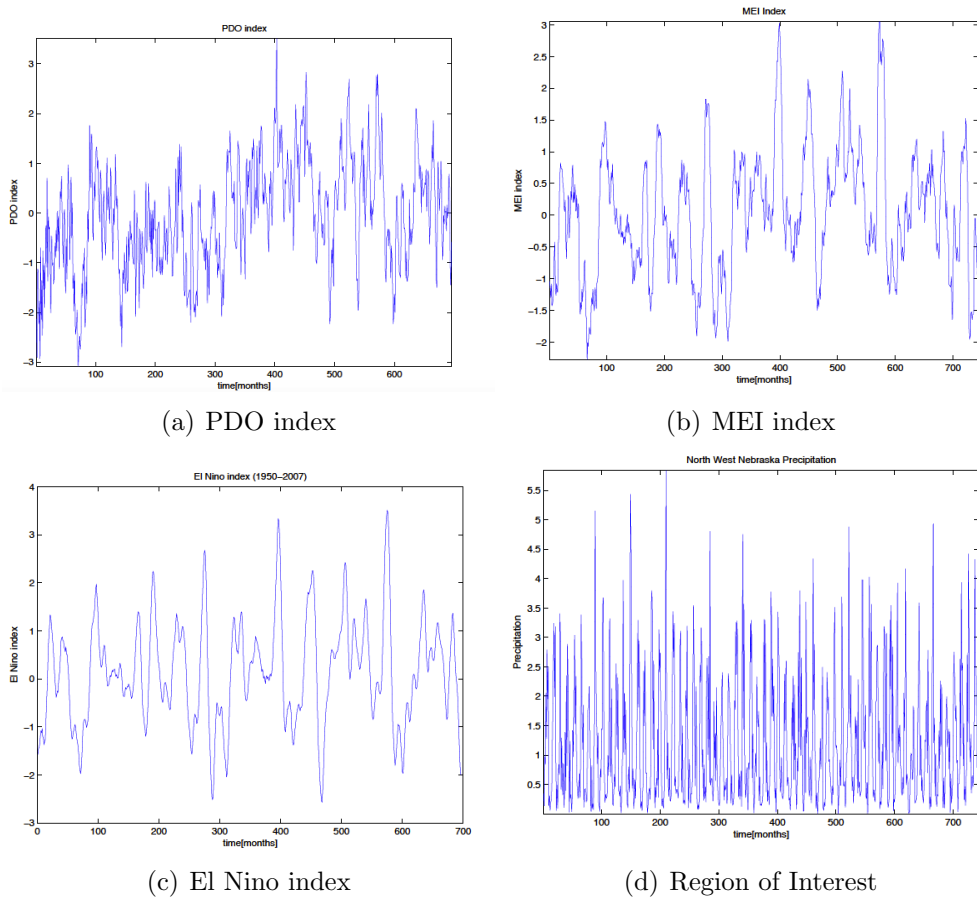
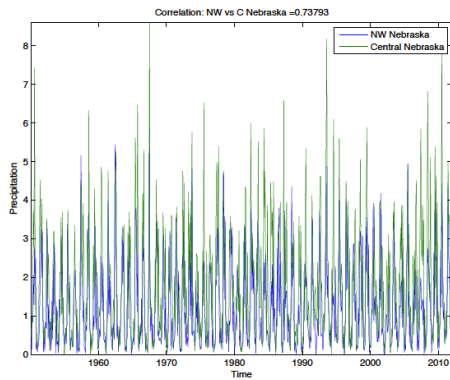

Figure 3: Time series of PDO index, MEI index, El Nino index and of the precipitation value in the region of interest

2- Correlation analysis

The first correlation analysis was performed between the precipitation (1950-2011) in the region of interest and the other four points in the domain. By observing figure 4 and table 2, it is possible to observe that the correlation decreases going toward east. This result is reasonable if we think that in the state of Nebraska, a precipitation gradient of 40 inches occurs going from east to west across the state, while the north-south gradient is much lower.



(a) Center Nebraska, $C=0.73$

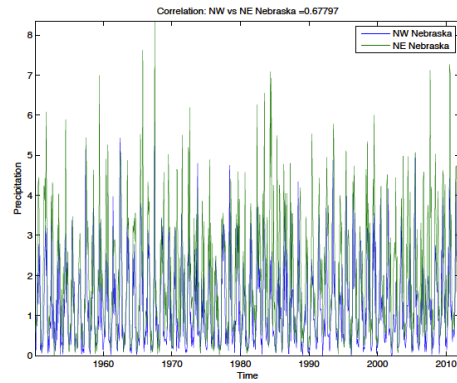

(b) North East, $C=0.67$

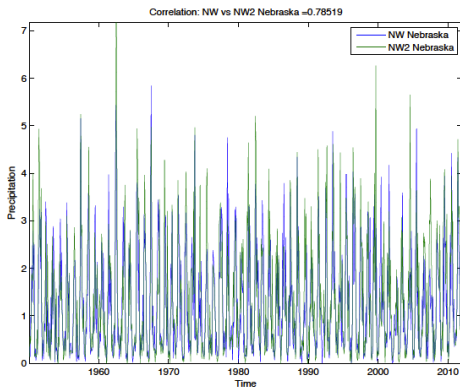

(c) North West $C=0.78$

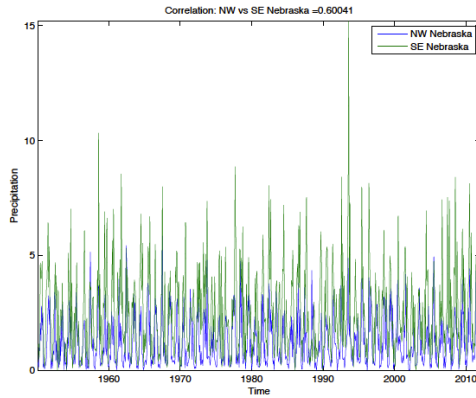

(d) South East, $C=0.60$

Figure 4: Correlation analysis with the other four point of interest

	C	NE N	NW2	SE
C value	0.73	0.67	0.78	0.60

Table 2: Correlation Values

The second correlation analysis was performed between the precipitation value of the selected area and the El Nino, MEI and PDO indexes. While for the MEI index no adjustment were needed, for what concerns the other two indexes, it was possible to perform the correlation analysis just for the period 1950-2007. In fact, the data availability for El Nino and for PDO is limited to those fifty-seven years. Figure 5 and table 3 shows the results of the correlation analysis.

Index	Correlation Value
PDO	0.12
MEI	0.07
El Nino	0.05

Table 3: Correlation NW Nebraska-Indexes Values

As a result of the analysis of figure 5 and table 3, it turns out that the correlation values in this case are approximately an order of magnitude lower than those computed when analyzing the other four regions in Nebraska. This result is reasonable, if we consider the fact that those indexes are the results of an aggregation procedure which involves a much broader spatial domain. As a consequence, they will reflect a general behavior, and not a specific one.

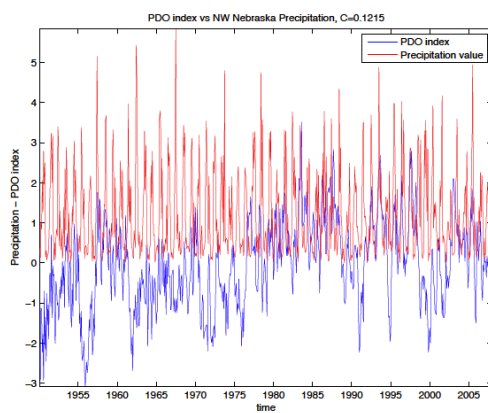

(a) PDO index, C=0.12

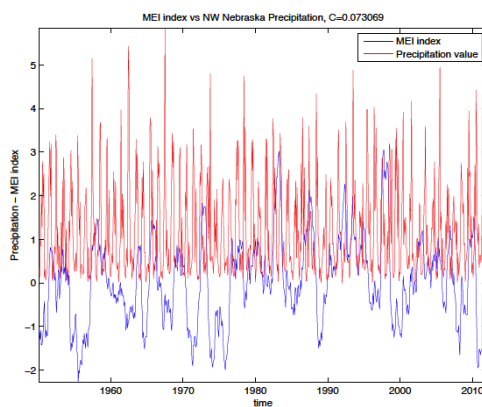

(b) MEI index, C=0.07

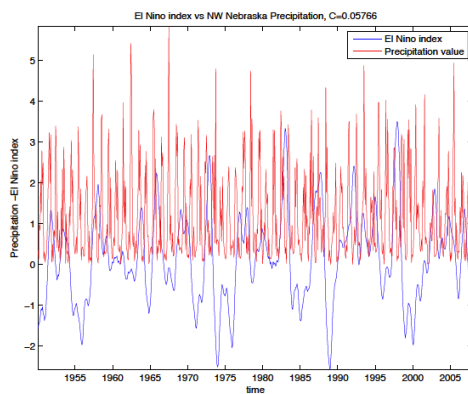

(c) El Nino index, C=0.05

Figure 5: Correlation analysis with PDO index, MEI index and El Nino index

3- Anomalies

The last analysis correlation analysis that we performed was the correlation analysis between the precipitation anomalies in the selected region and the precipitation anomalies in the other four regions of interest. The anomaly is defined as the difference between the time series and the climatology. Practically, if we want to take the example of the area of interest, from the time-series in figure 1, the climatological component (figure 6(a)) is removed, and the result is the green trendline in figure 6(b). Moreover, figure 7 shows the anomalies for the other four regions of interest.

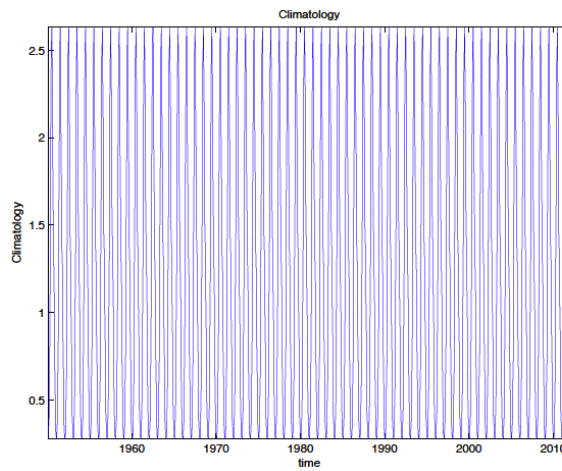

(a) Climatology

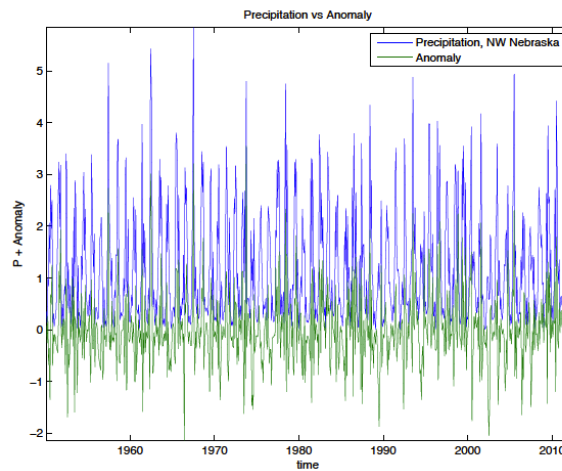

(b) Precipitation Anomaly

Figure 6: Climatology and precipitation anomaly

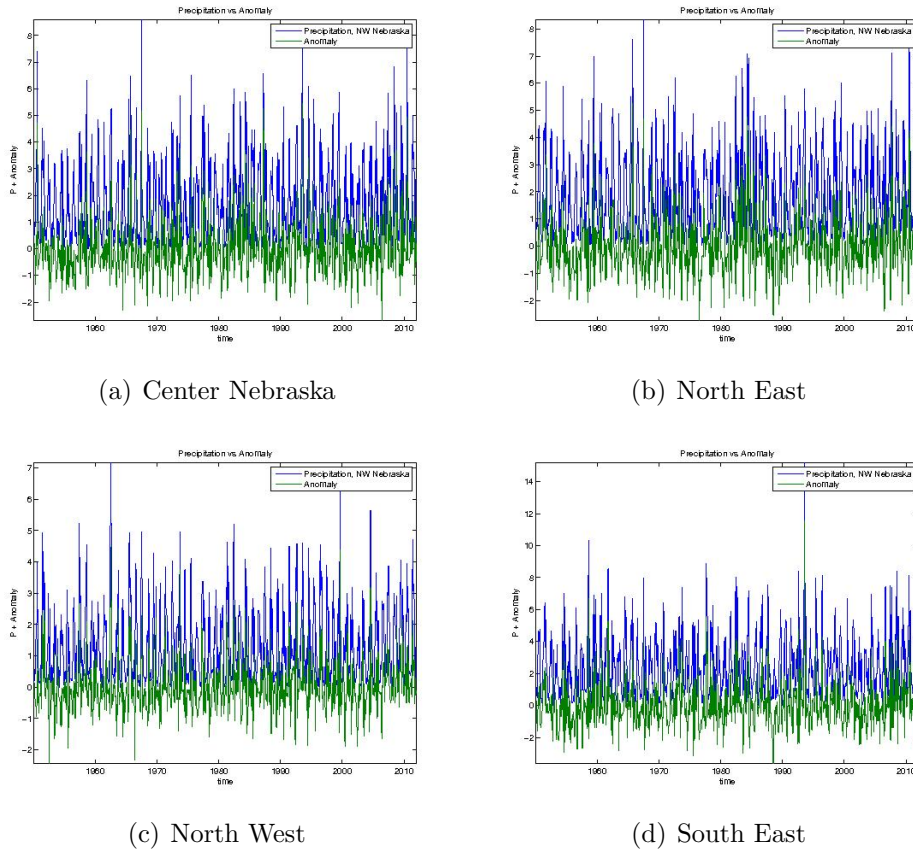
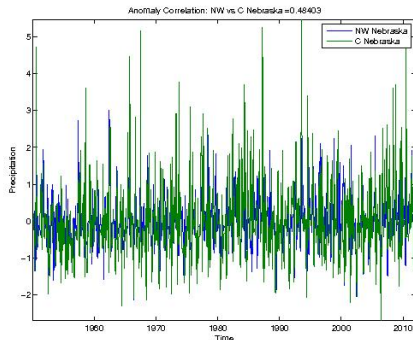
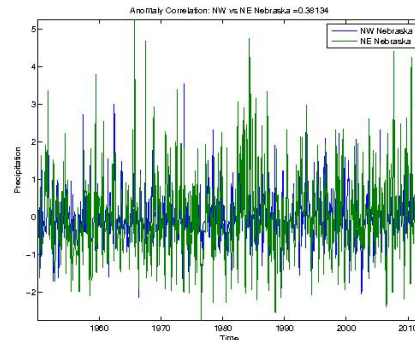

Figure 7: Precipitation Anomaly in the other four point of interest

Figure 8 and table 4 shows the result of the correlation analysis between the precipitation anomalies in the region of interest and the other four selected points in Nebraska. The most interesting results is that the anomalies correlation trend follows exactly the precipitation correlation trend, i.e.: if the highest (or lowest) precipitation correlation is found with NW2, the same would be true for the anomalies' correlation. However, despite the trends are exactly the same, the absolute value of the correlation decreases when we analyze the anomalies. This result is again reasonable, since anomalies represents deviation from the trend, and so the probability of dissimilarity becomes higher.



(a) Center Nebraska, $C=0.48$



(b) North East, $C=0.38$

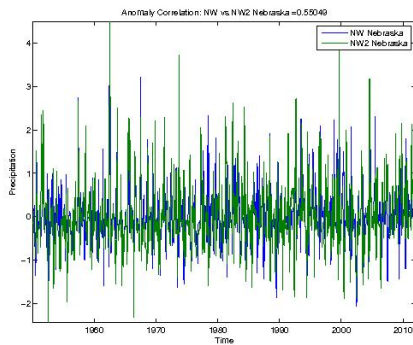

(c) North West, 0.55

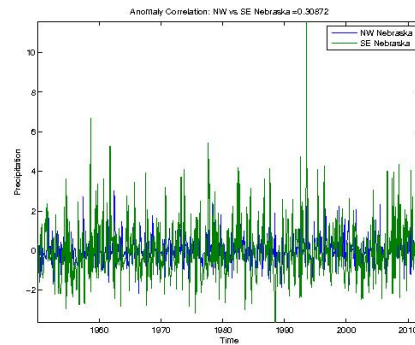

(d) South East, $C=0.30$

Figure 8: Correlation analysis of the precipitation anomalies with the other four point of interest

Region	Correlation Value
C	0.48
NE	0.38
NW2	0.55
SE	0.3

Table 4: Correlation Anomalies: NW Nebraska-Nebraska regions Values

4- Comparison with Vasudha's results

I compared my results with those obtained by Vasudha. For what concerns the correlation with the indexes, we can say that we obtained approximately the same results. Since, as already said, indexes are the result of a huge aggregation process, it is reasonable to expect small correlation both in my domain and in Vasudha's. For what concerns the correlation with other four

points, Vasudha Obtained higher results. This is due to the fact that she choose point that were located inside her domain, and therefore the resulting correlation is higher, while I was looking for the spatial variability, and I obtained lower values.

Table 5 contains average correlation values for all the three correlation analysis performed in the lab (Spatial, Indexes and Anomalies) by Vasudha and me.

	Alessandro	Vasudha
Spatial	0.69	0.91
Index	0.08	0.11
Anomaly	0.42	0.83

Table 5: Comparison with Vasudha results

Directories

The data are located in the following directories:

- /work/nres879/alessandro/Lab3/Data
- /work/nres879/alessandro/Lab3/Plot
- /work/nres879/alessandro/Lab3/Scripts

Name: _____

Individual Points: _____

Team: _____

Team Points: _____

Total: _____

NRES/METR/BSEN 479/879

Spring 2016

Assignment No. 3

Project MODELLING

Due: Thursday, April 17th

Educational Objectives:

By completing this exercise students will better understand how to use a model. Also, is aimed to implement the methodology you propose for your final project and obtain the results you will be presenting. Please make sure you address the following aspects for the present activity:

- » Develop a Perceptual, Conceptual and Procedural Model (narrative articulating the following information)
- » Develop figure(s) that show your area of study-Use arcGIS (include topography)
- » Develop a figure(s) and analysi(e)s that evidences your research question and support your hypothesi(e)s-For example, use observation data (from Livneh et al 2015)

Please make sure you address the following aspects for **FINAL-PROJECT-VIC users**:

- » Develop a figure with the discretized (1/16th degree resolution) domain
- » Figure of the spatial distribution of precipitation (preferable climatology)
- » Develop a figure with the temporal variability of precipitation, and three more variables or state variables
- » Develop figures involving composite development of precipitation and an additional variable or state variable(s) of your interest.

Please make sure you address the following aspects for **FINAL-PROJECT-NON-VIC users**:

- » Develop figures that show every step in the labs 4-6 (you should have them already)
- » Develop figures related with your model or observations analyses showing the spatial component of your approach
- » Develop figures related with your model or observations analyses showing the temporal component of your approach
- » Develop figures involving composite development of precipitation and an additional variable or state variable(s) of your interest.

REPORT

Your report is individual and requires bullet-type of narrative describing your results. Use this exercise as leverage toward your project

NRES/METR/BSEN 479/879
Spring 2016 Assignment No. 3
Project MODELLING

Develop a figure with the discretized (1/16th degree resolution) domain

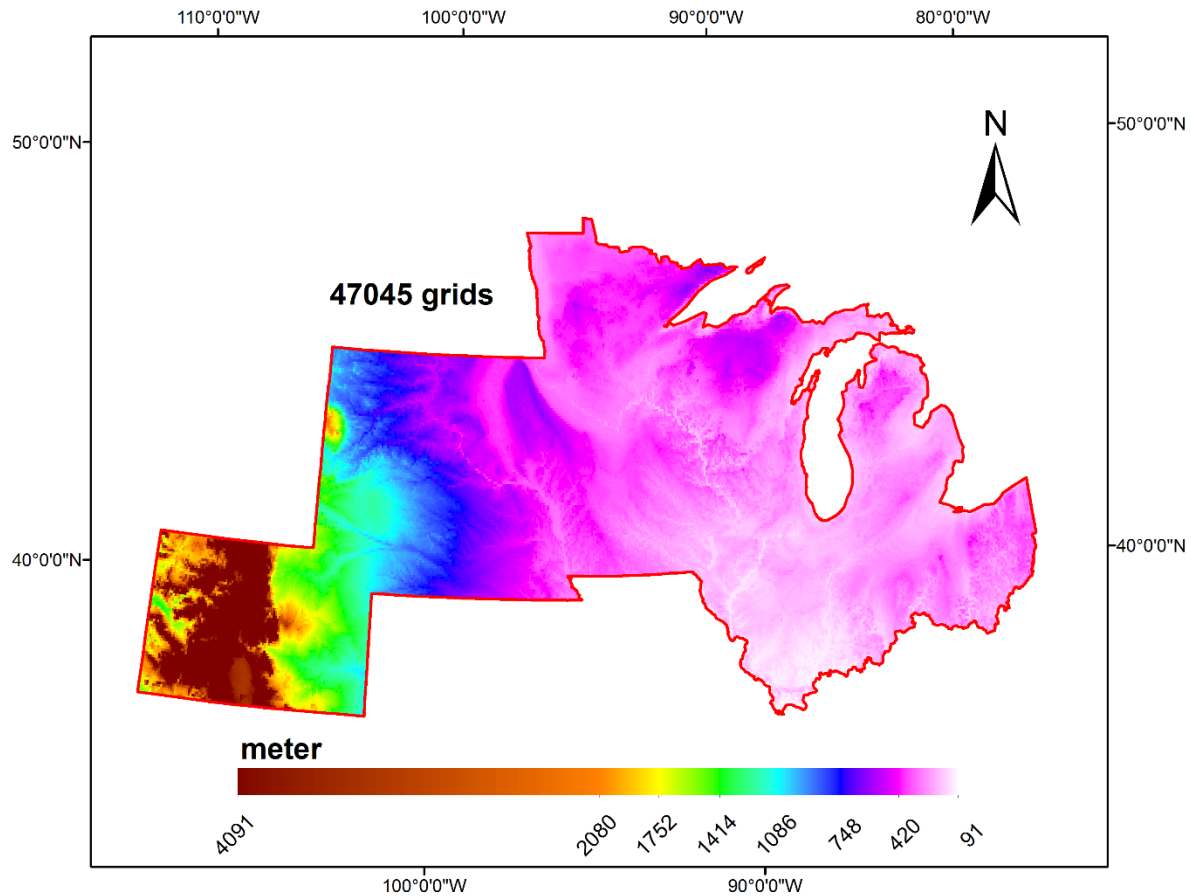

Figure 1

- Figure 1 is the discretized figure of my domain which is the Corn Belt of the USA. The total number of grids in my domain is 47045. Each grid size is 1/16 of a degree.
- Figure 2 is a zoomed in version of the grids in Cherry county, NE which is one of the counties selected for analysis.

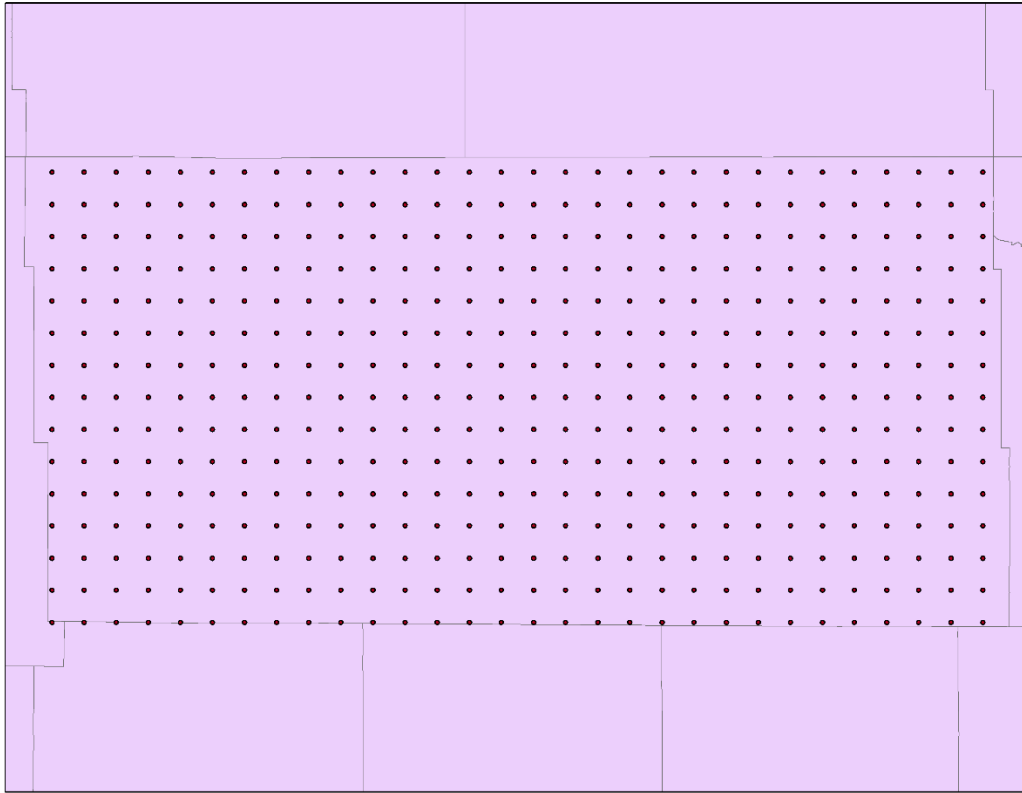

Figure 2

Figure of the spatial distribution of precipitation (preferable climatology)

- For this assignment, I am developing the climatology of the July precipitation in Cherry County, NE.
- I will be limiting my analysis for this assignment to Cherry County, NE.
- For the final project, I'll develop all analysis for all the 12 selected counties.
- Also, since July is the peak crop growth month, I will be limiting my flux analysis to July.
- Figure 3 shows the precipitation climatology for July for Cherry County, NE.

July Precipitation (mm/d)

Value

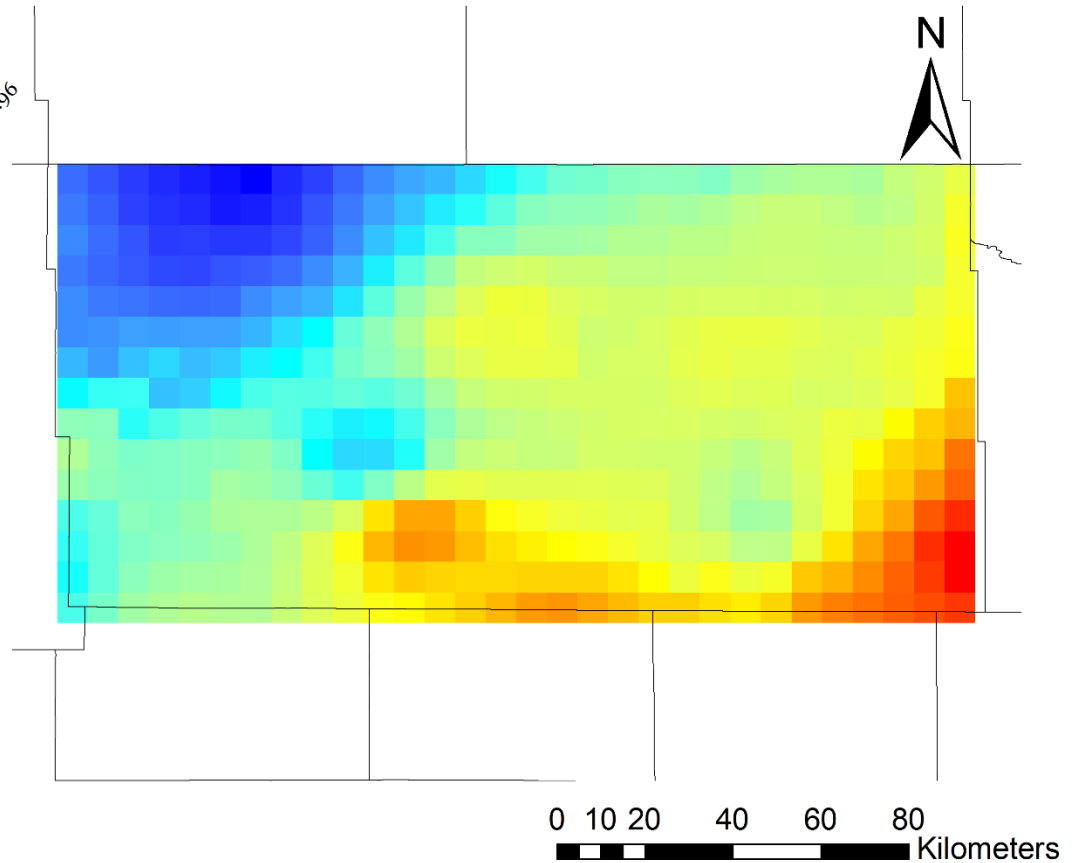
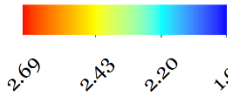

Figure 3

Develop a figure with the temporal variability of precipitation, and three more variables or state variables

- **Variability in Precipitation**

- Figure 4 shows the July precipitation temporal variability aggregated over all the grids in Cherry County, NE from the period 1960-2013.
- Figure 5 shows the July precipitation anomalies.
- Mean and standard deviation of the time series was calculated.
- Identification of wet and dry years was performed.

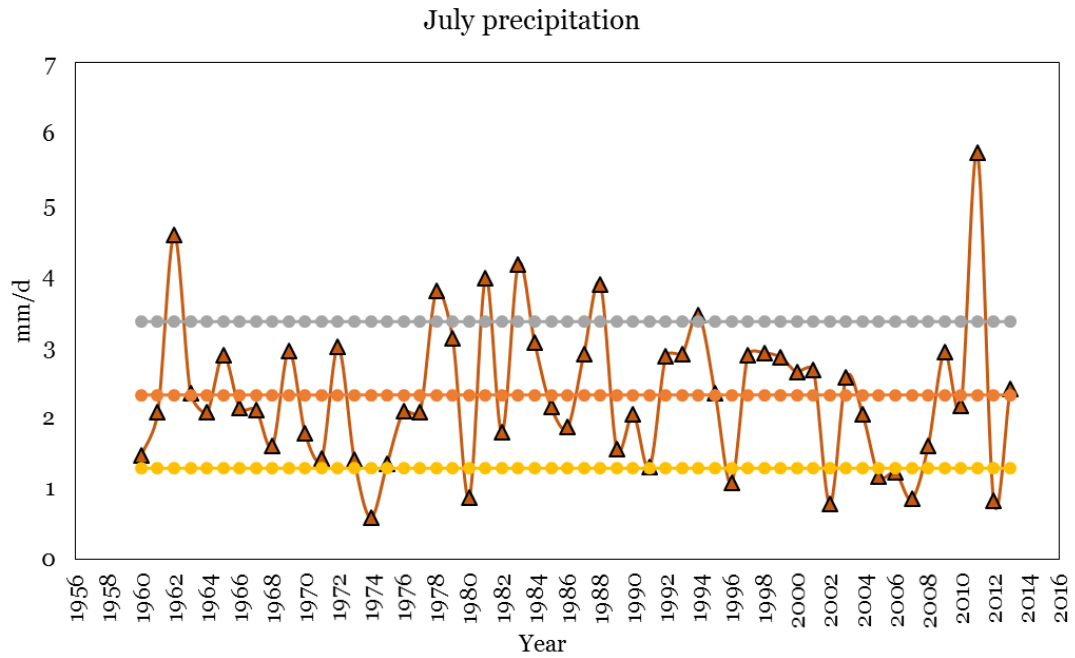

Figure 4

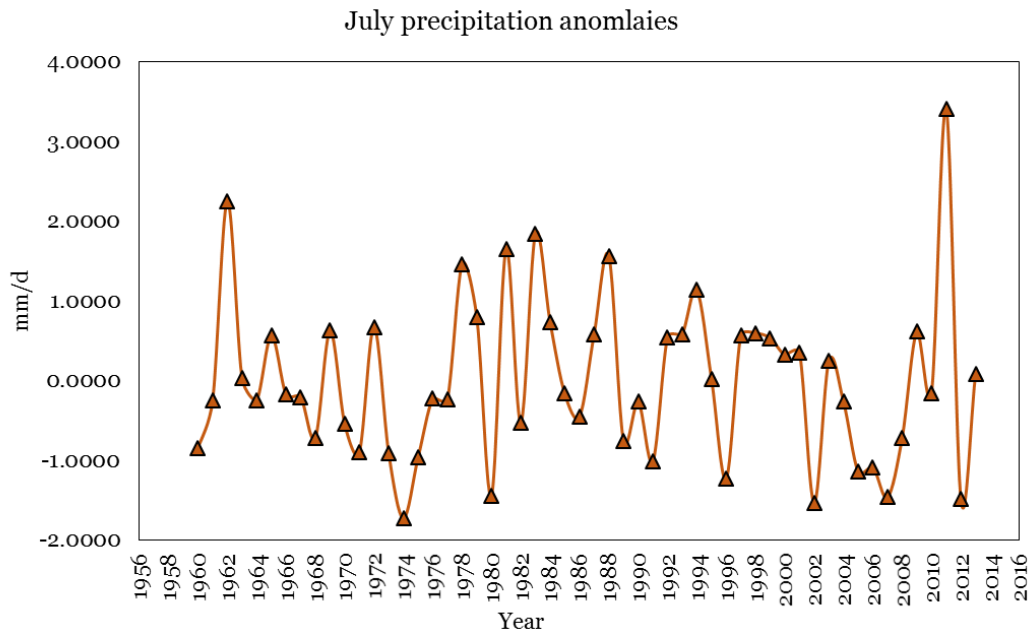

Figure 5

- **Variability in Evapotranspiration**
 - Figure 6 shows the July ET temporal variability aggregated over all the grids in Cherry County, NE from the period 1960-2013.
 - Figure 7 shows the July precipitation anomalies.

-
- Mean and standard deviation of the time series was calculated.
- Identification of extreme high and low ET years was performed.

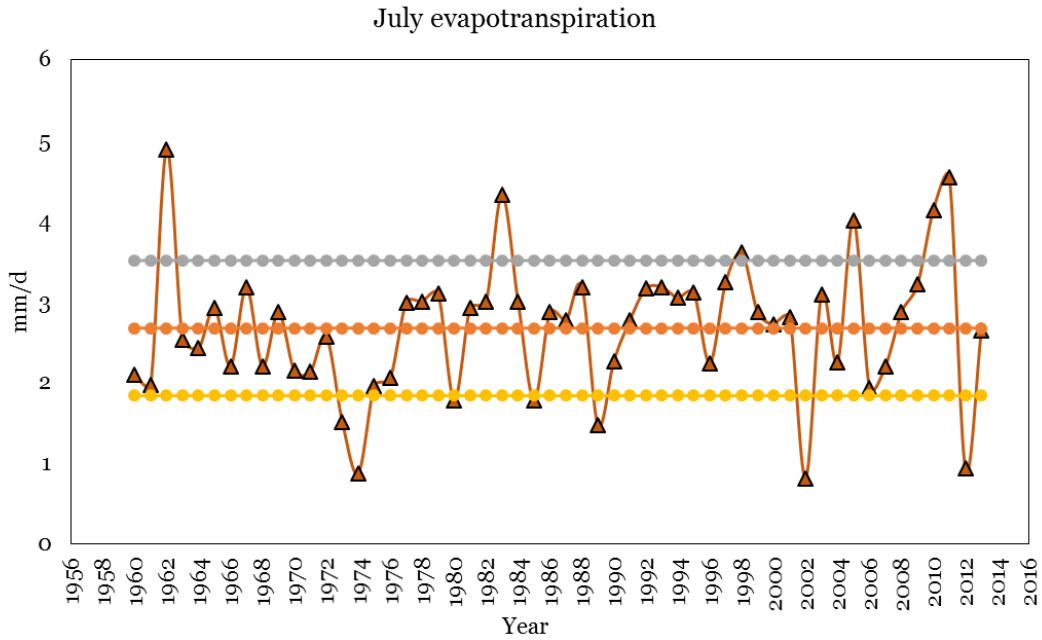

Figure 6

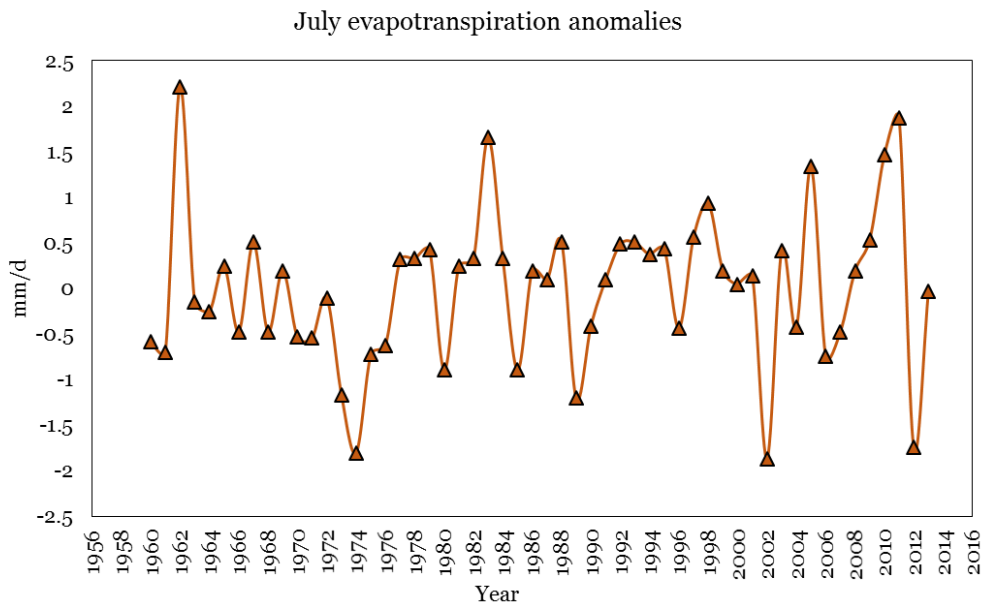

Figure 7

- **Variability in Baseflow**

- Figure 8 shows the July baseflow temporal variability aggregated over all the grids in Cherry County, NE from the period 1960-2013.
- Figure 9 shows the July baseflow anomalies.

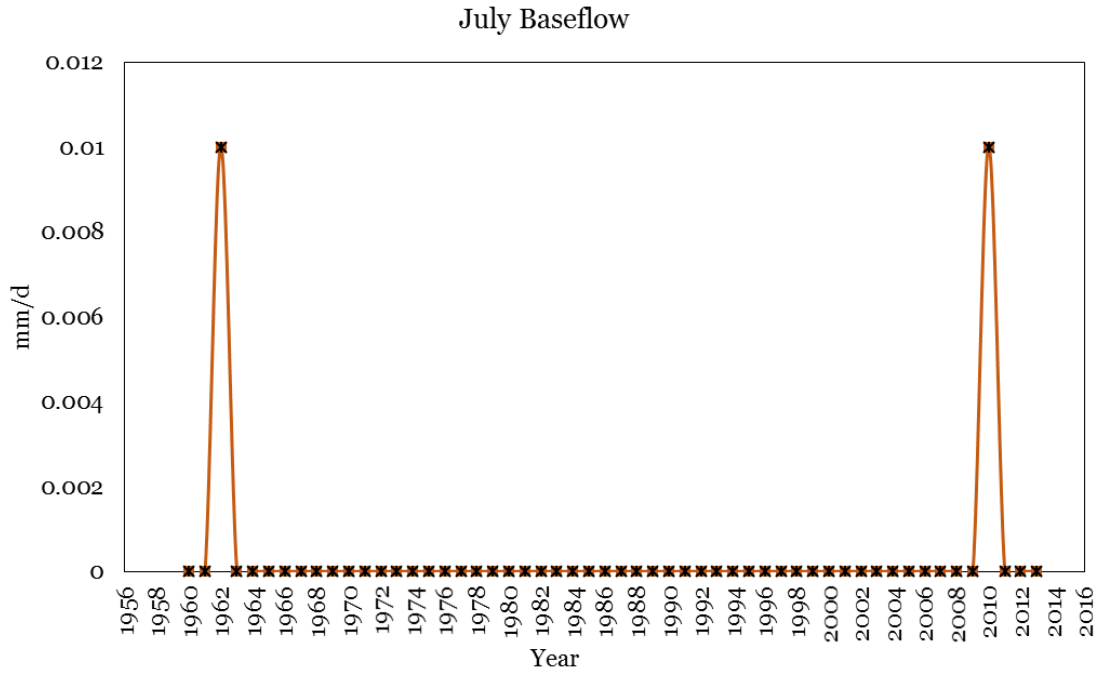

Figure 8

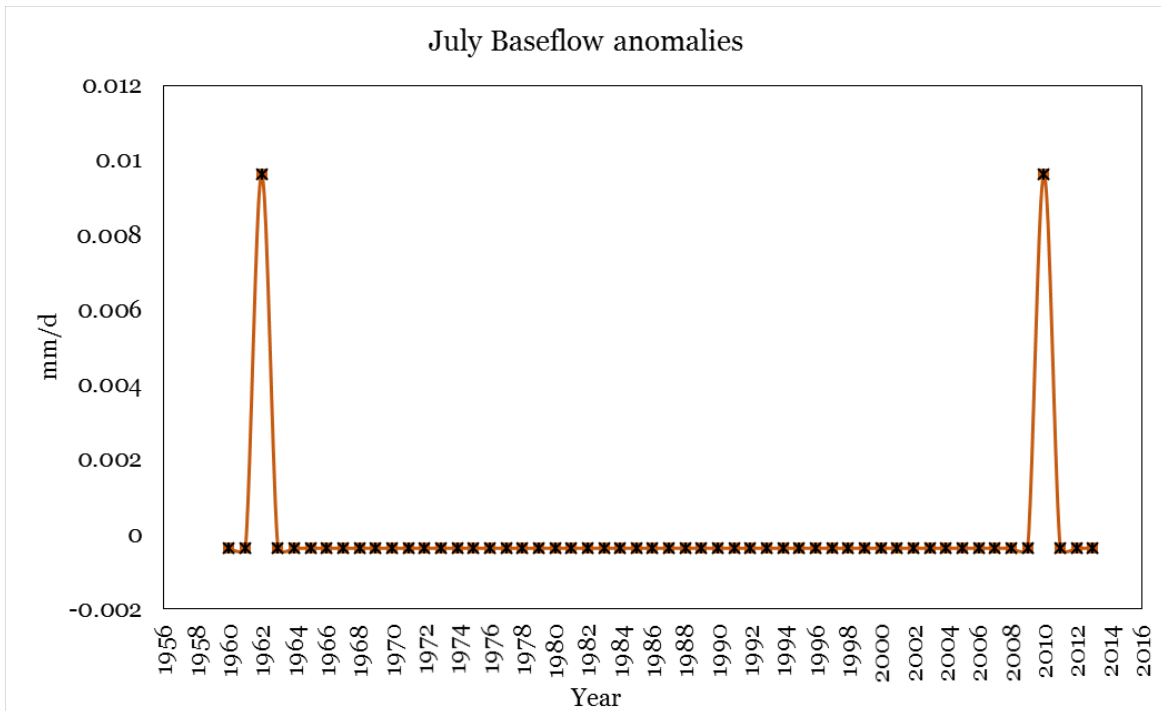

Figure 9

- **Variability in Runoff**

- Figure 10 shows the July runoff temporal variability aggregated over all the grids in Cherry County, NE from the period 1960-2013.

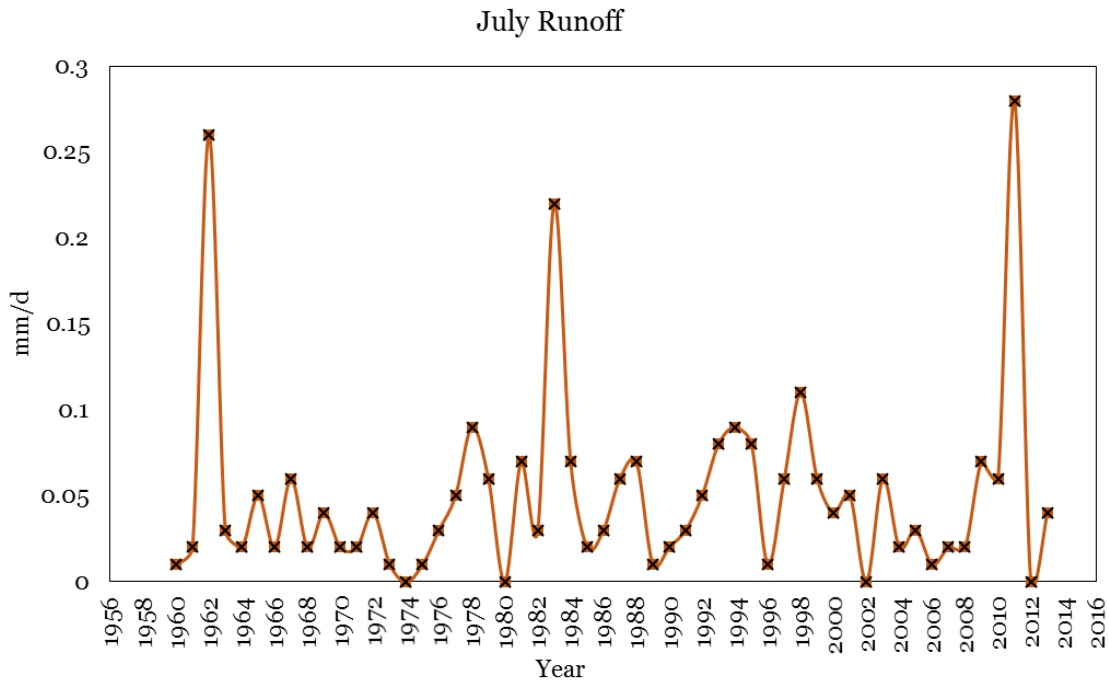

Figure 10

Develop figures involving composite development of precipitation and an additional variable or state variable(s) of your interest.

Composite development for precipitation:

- Using mean and standard deviation of the time series of precipitation and evapotranspiration, wet and dry years were identified and used for composite development for these two variables.
- Figures 11 and 12 depict dry and wet precipitation composites for July for Cherry county, NE.
- Figures 13 and 14 depict dry and wet precipitation composites for July for Cherry county, NE.

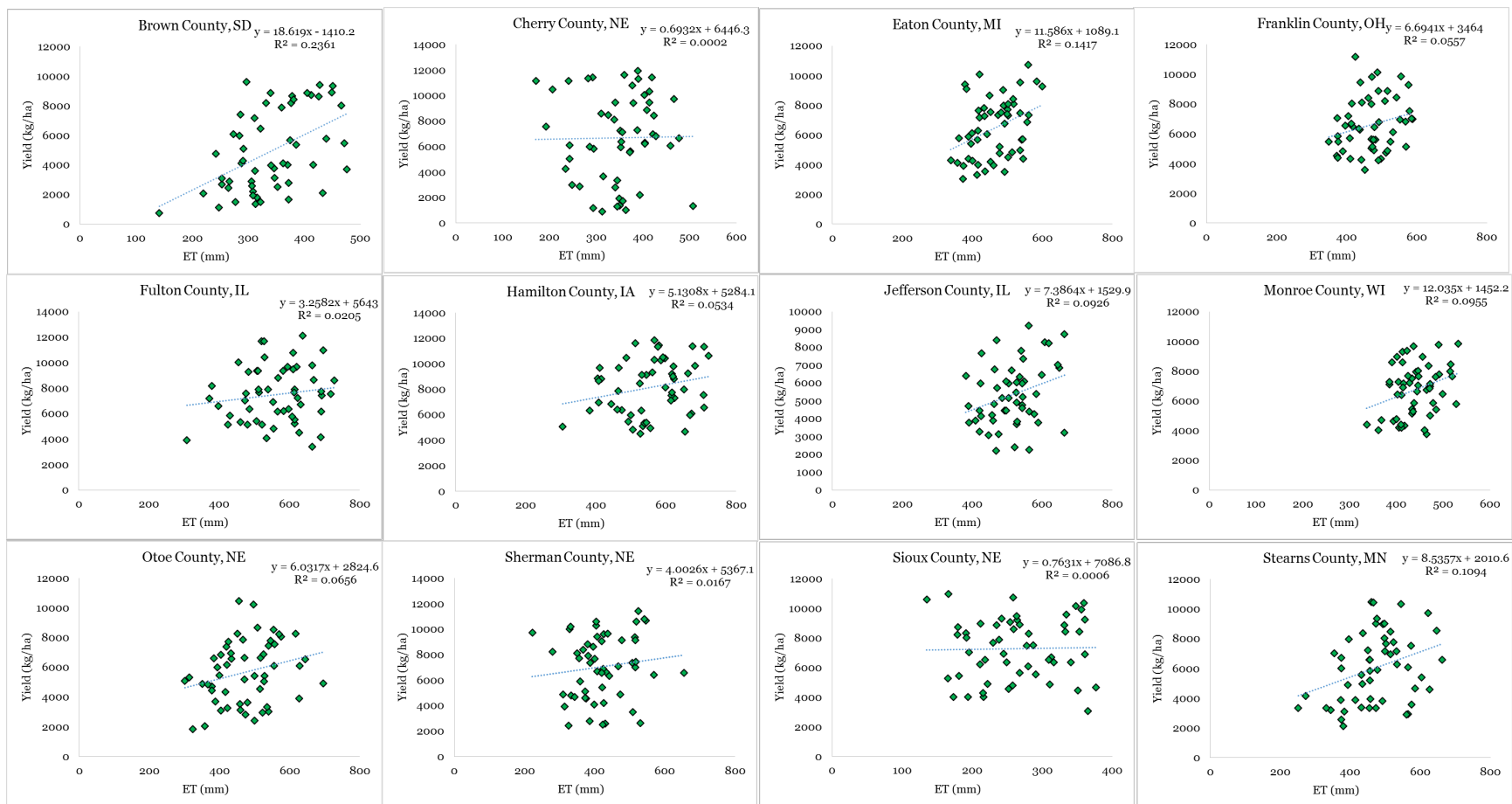

Figure 20

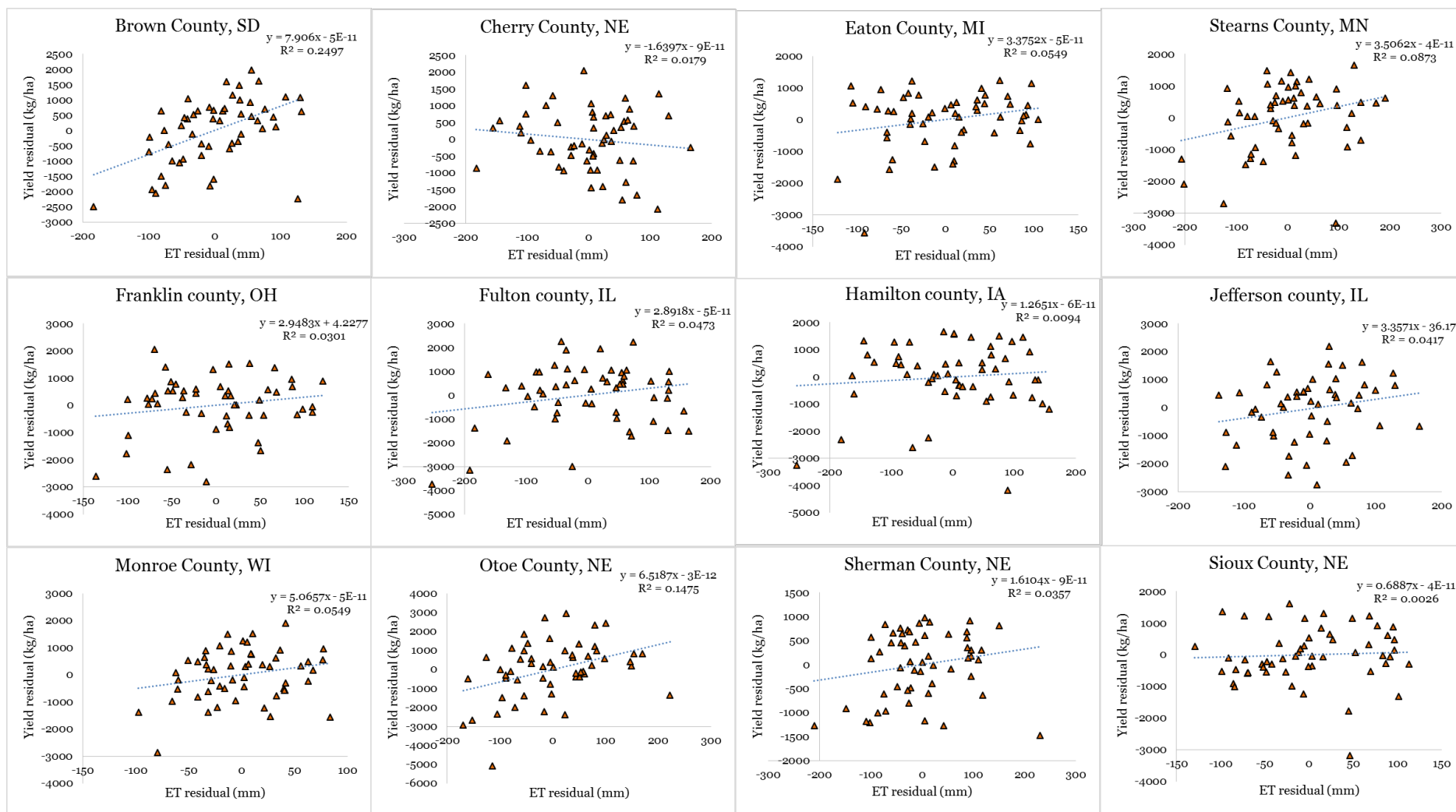

Figure 21

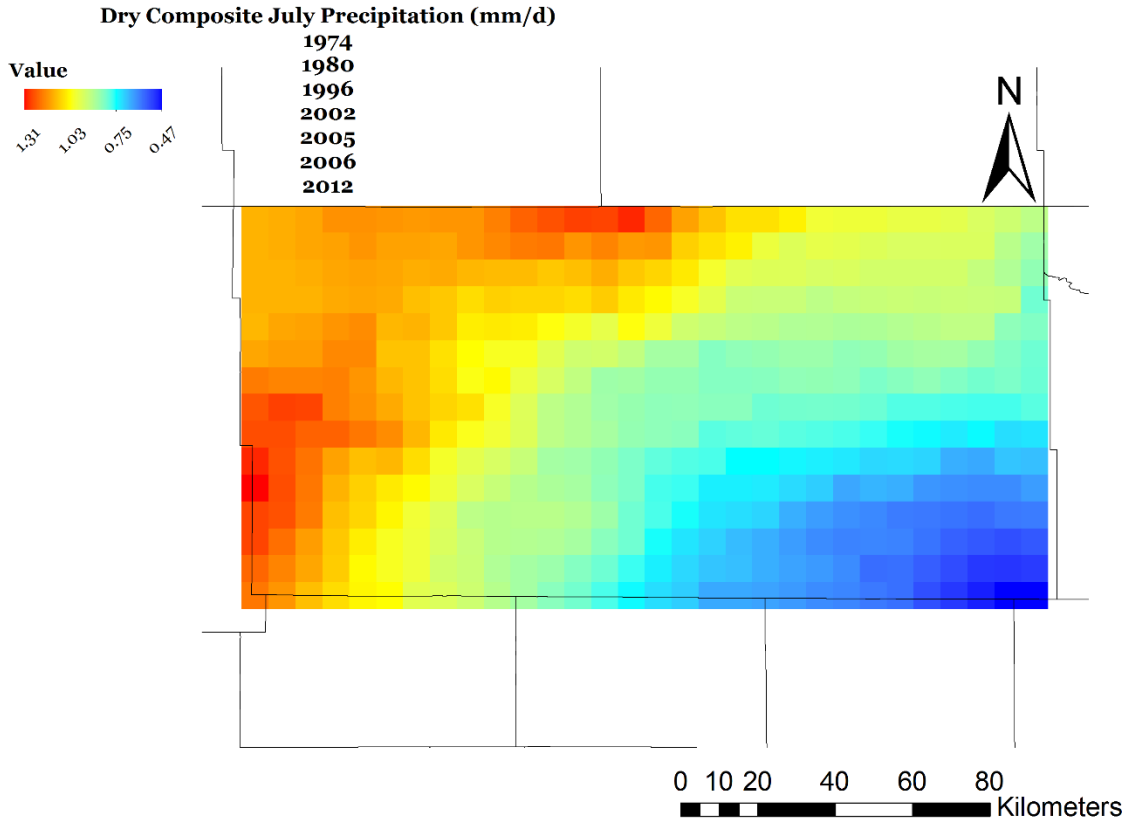

Figure 11

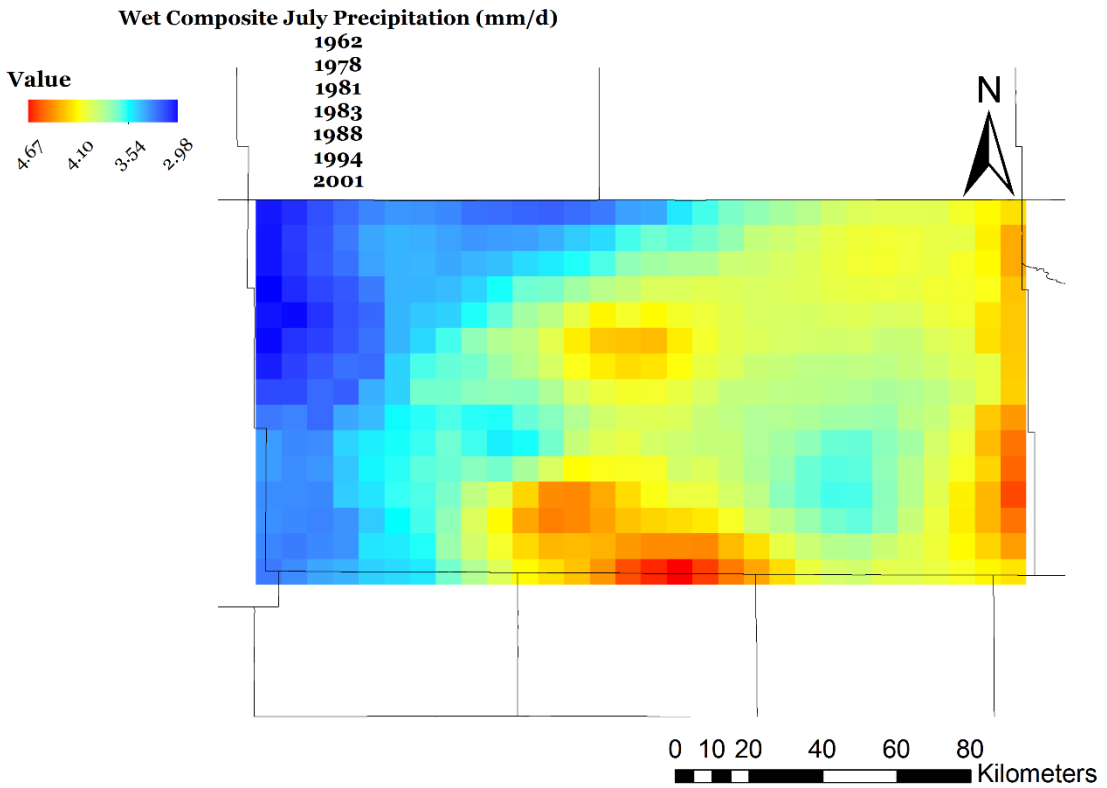

Figure 12

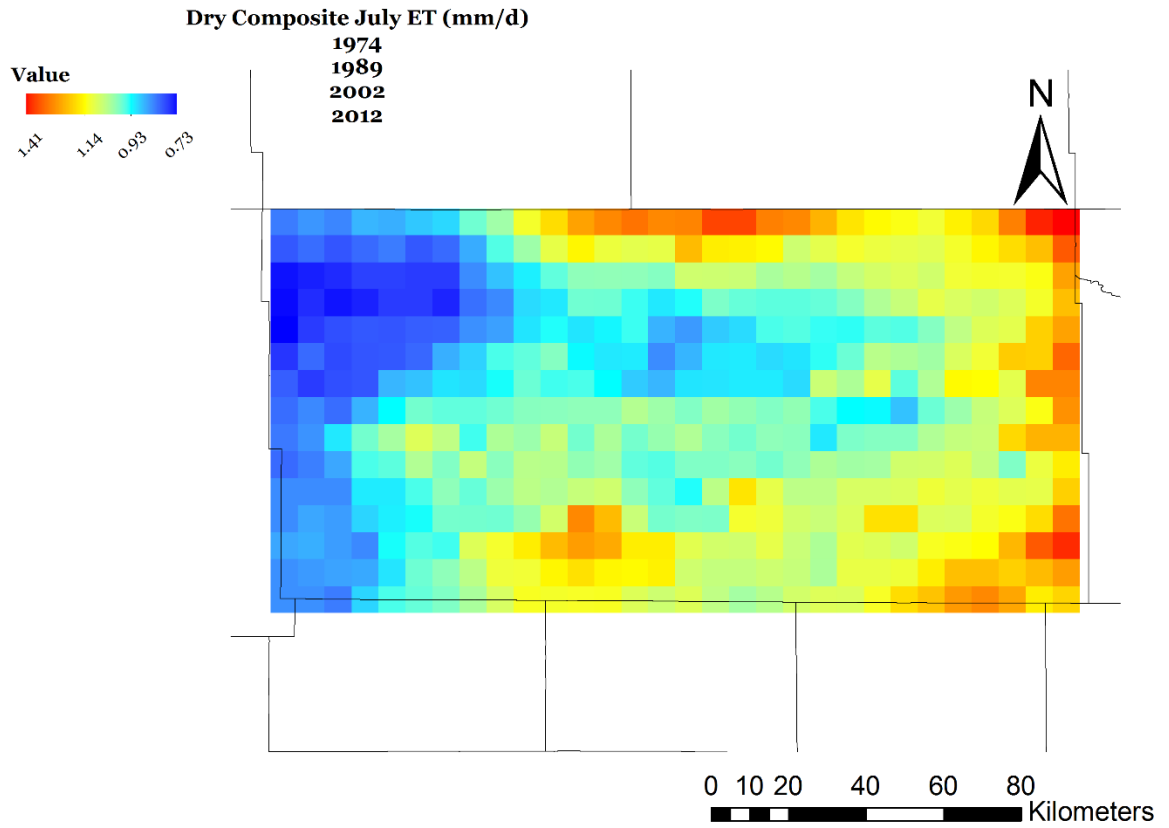

Figure 13

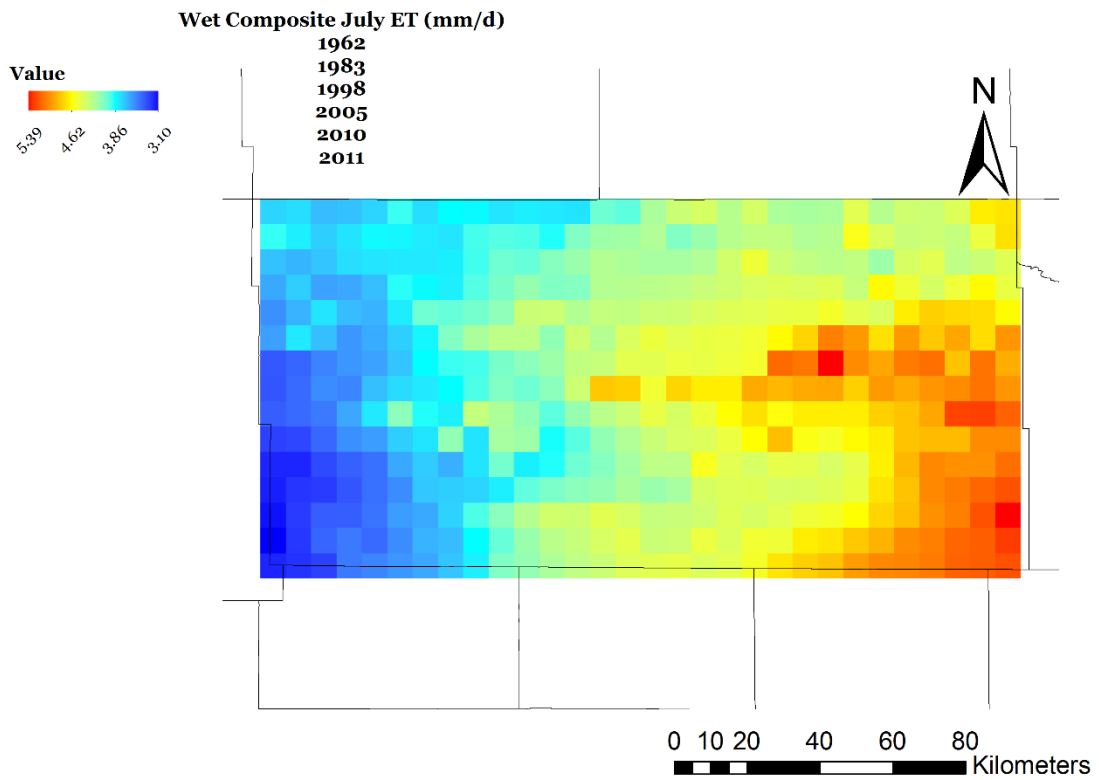

Figure 14

ADDITIONAL RESULTS: NOT ASKED IN THE ASSIGNMENT BUT RELEVANT TO MY PROJECT.

Yield Analysis:

- Corn Yields for all the 840 counties in the Corn Belt were obtained from NASS-USDA.
- They were inspected for continuous records for the period 1960-2013.
- Long-term averaged corn yields were calculated and mapped (Figure 15).
- Trends were determined for 540 counties and mapped (Figure 16).

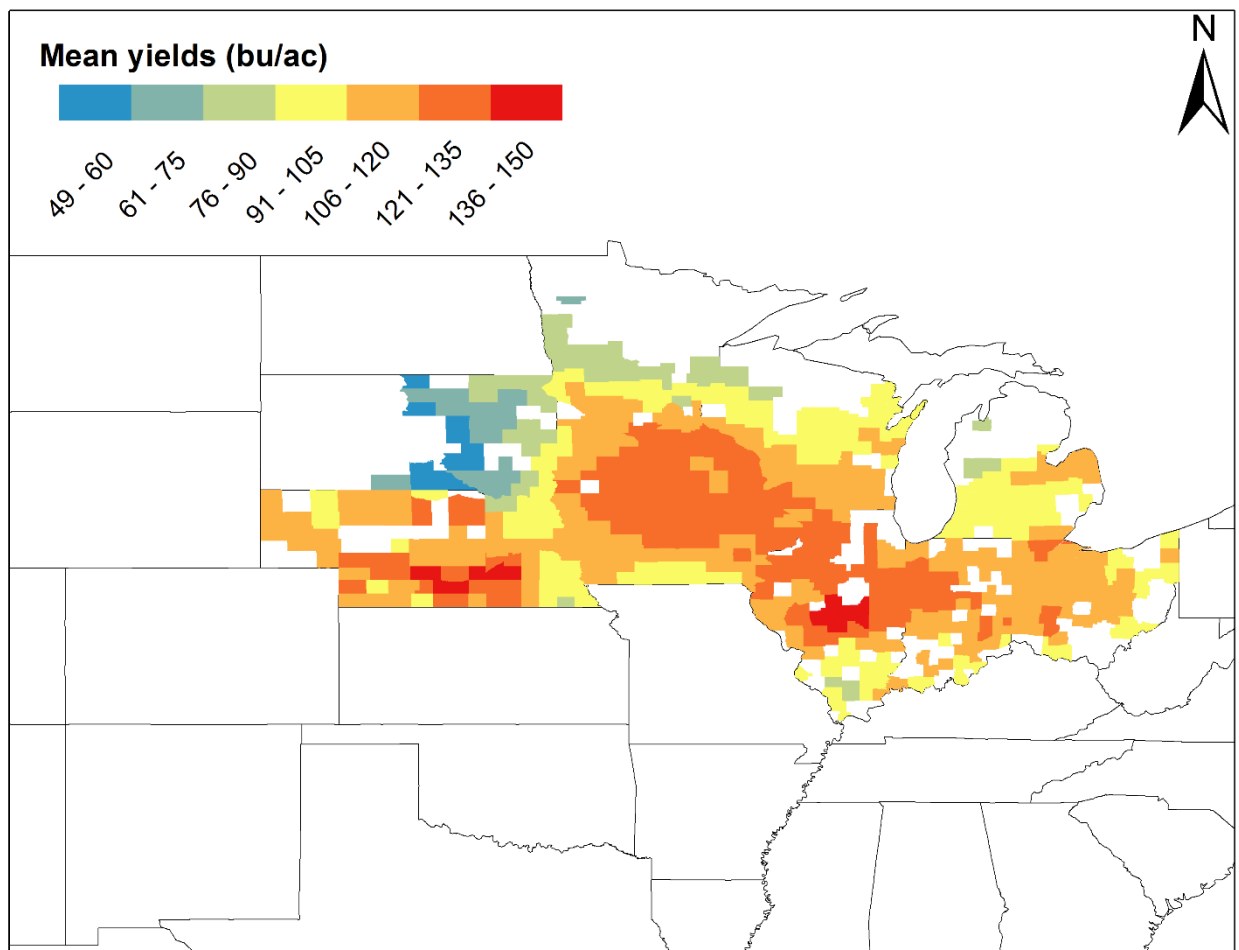

Figure 15

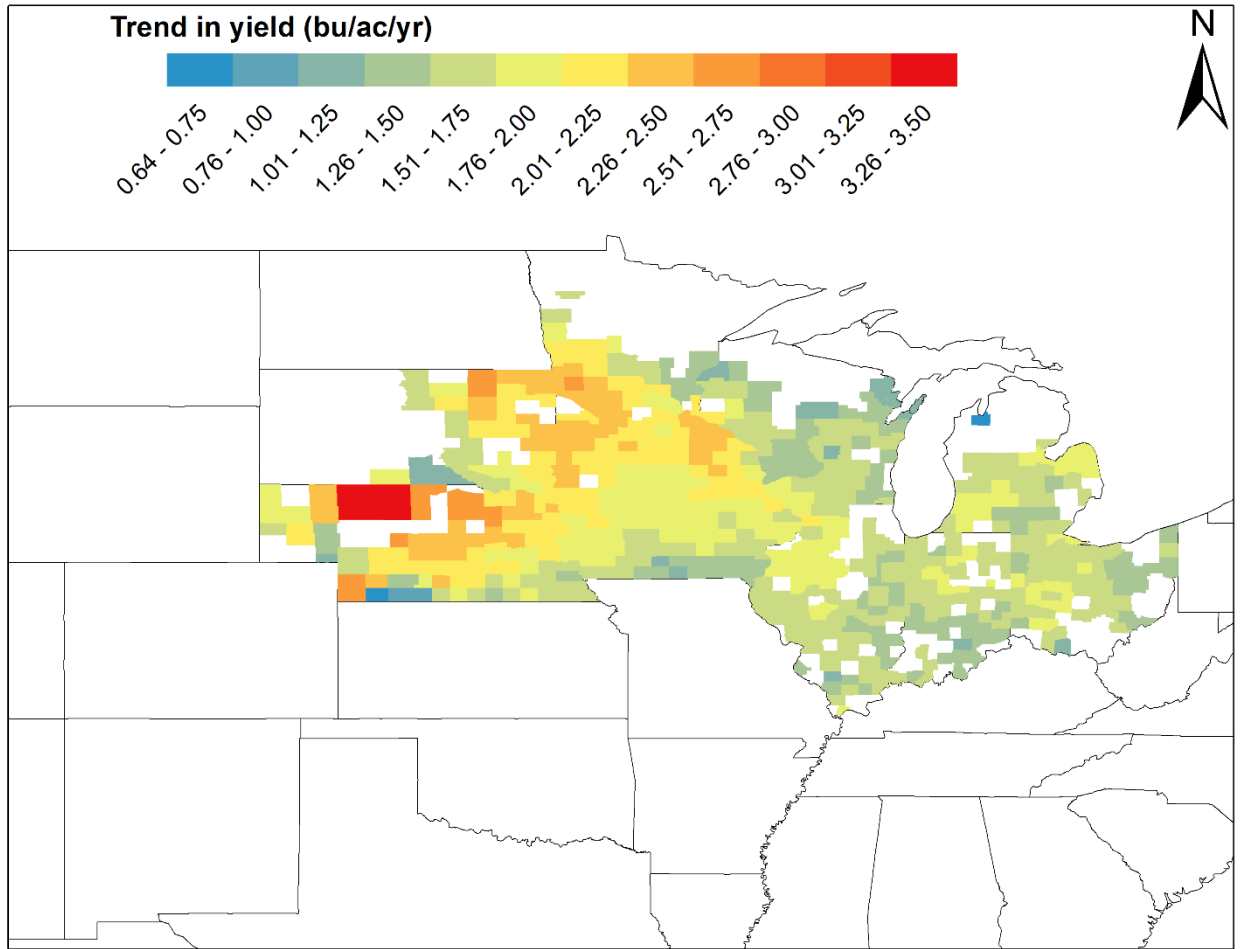

Figure 16

- 12 counties were selected for further analysis in the Corn Belt to represent the geographical variability in the region.
- These were:

Brown County, South Dakota

Cherry County, Nebraska

Eaton County, Michigan

Franklin County, Ohio

Fulton County, Illinois

Hamilton County, Iowa

Jefferson County, Illinois

Monroe County, Wisconsin

Otoe County, Nebraska

Sherman County, Nebraska

Sioux County, Nebraska

Stearns County, Minnesota

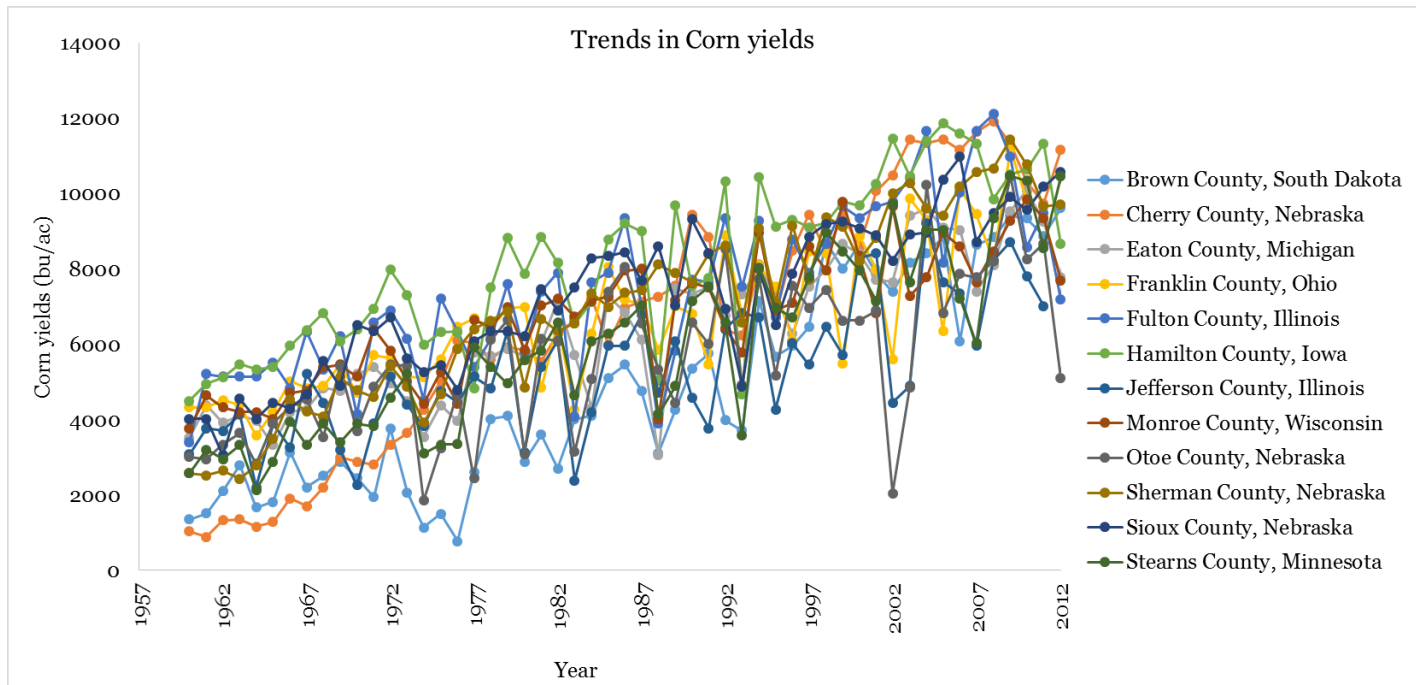

Figure 17

- The growing season ET was quantified (1 May- 30 September) for each of the 12 counties and every year.

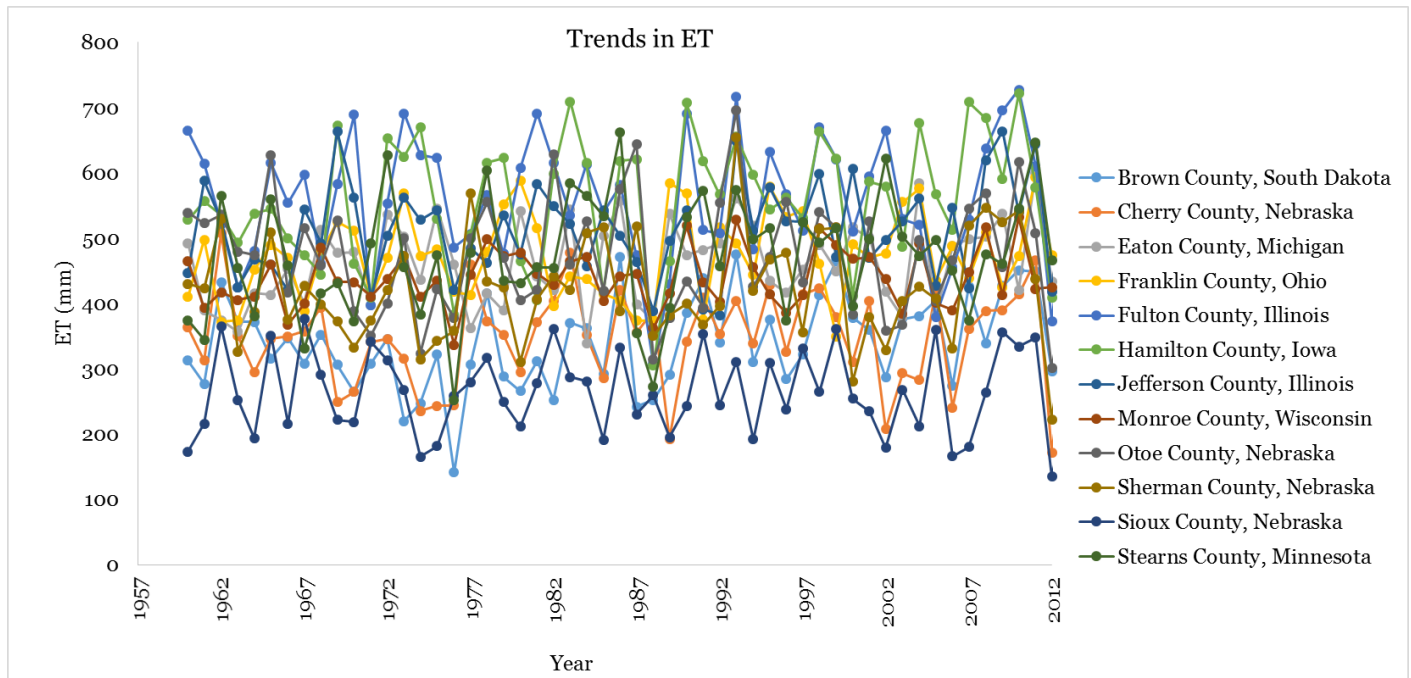

Figure 18

- Water use efficiency was calculated for each county and every year by ratioing the crop yields to ET.

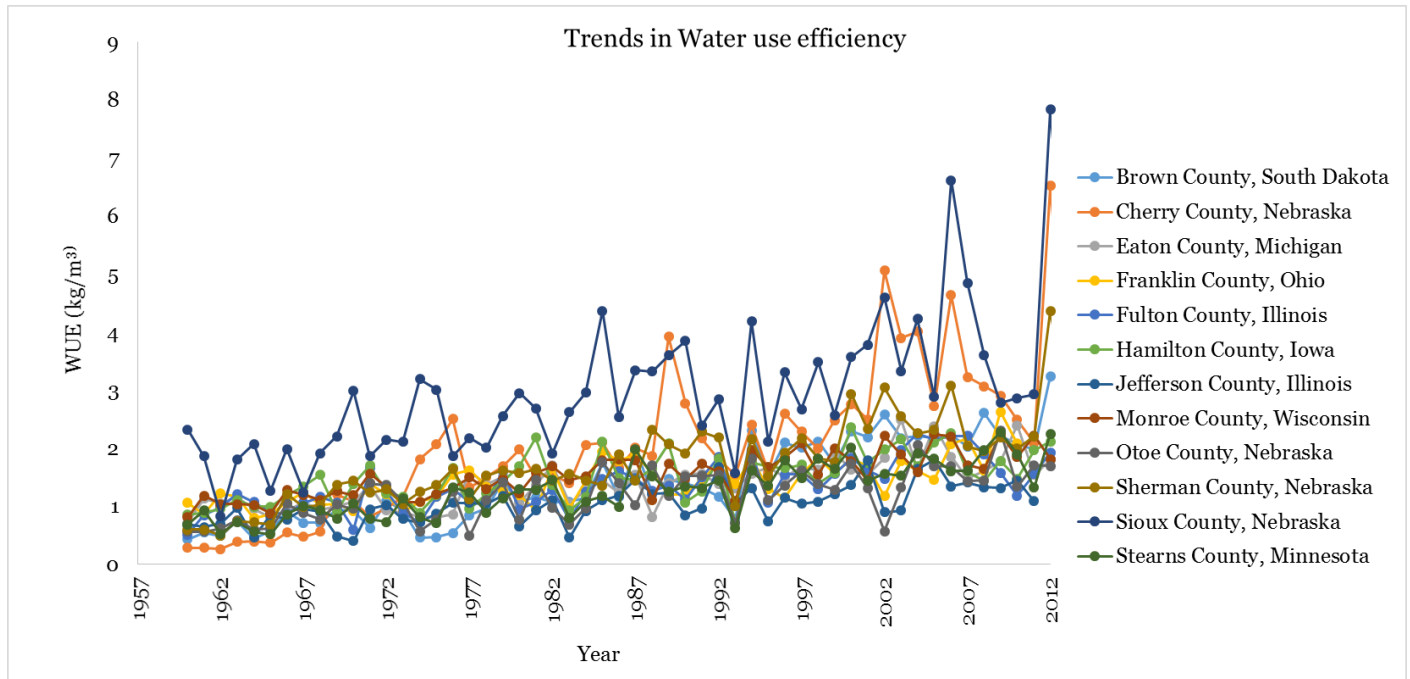

Figure 19

- Crop production functions were calculated for each county by relating crop yield to ET (Figure 20)
- Both the yields and ET fluxes were detrended and explored for correlations (Figure 21).

Appendix 6

Type your Concept Paper Title Here

Note: Limit your white paper to no more than two pages in length.

1. Overall Goal and Objectives

What do you wish to accomplish? What are you trying to do? What objectives/aims must be completed to achieve success? State in plain language using no jargon.

2. Problem to be Addressed

What pressing scholarly issue are you trying to address with this research? How is it currently done and what are the limits of that?

3. Approach

What is new in your approach, and why do you think it will be successful? How will you fix the problem? What is innovative about your idea?

4. Potential Impacts/Outcomes

If you are successful, what difference will it make? What specific outcomes do you expect your work to produce? What are expected impacts of the proposed work on the field? Why should the funder care?

5. Anticipated Budget

What do you estimate the project to cost? How long will it take?

6. Contact Information

For more information, please contact:

Dr. Jane Smith

Department of White Paper Writing
University of Nebraska-Lincoln
smithj500@unl.edu
(402) 472-5555

Some Ideas on Writing a Successful Proposal

1. A written proposal is a Persuasive Document.
 - A proposal is not a scholarly treatise on the subject.
2. Remember that You Want Something.
 - You want money to support your research and students. Support is competitively earned and not an entitlement.
3. Is the proposal Easy to Read?
 - If the reader has to slog through the text, you will lose your reader's support.
4. Is it Interesting?
 - Express your passion and the importance of the research.
 - Will the reader learn something new or look at something with a new perspective?
5. Tell a Story.
 - Bring the reader along on your journey. All stories have a beginning, end, and a plot.
6. Be an Honest Guide.
 - Don't overstate your claims. If things are so well known, it isn't research. The point of research is to push the bounds of the known and to challenge the status quo.
7. Newton's Law of Motion is not just a scientific law, it describes human reactions.
 - An action produces an equal and opposite reaction. For example, writing that "No other possible explanation exists." is an invitation to find out from a reviewer that one actually does and it will be raised in a way that casts serious doubt on the strength and truthfulness of your argument as well as your grasp of the literature.
8. The Body Language of a proposal is important.
 - It is your first impression about you or at least your idea (if you are a seasoned scientist).
 - The layout expresses your desire to be taken seriously -- extensive typos, missing captions say that you are not serious about the proposal. Don't be afraid of white space and don't shrink the font to capture all of what you want to write.
9. Pace and Movement of writing is important.
 - Write at the pace of a brisk walk.
10. Show the Reader the Way Home
 - Lead them to yes; let the reader agree that the research should be funded.



Appendix 7

Name: _____

NRES/METR/BSEN 479/879
HYDROCLIMATOLOGY
Midterm Exam
April 7th, 2016

Exams are tools to evaluate our understanding as well as to continue our learning activities. The questions below are aimed to assess your understanding on Lectures, Discussions, and Labs (for the Open-Book question). Your answers will be evaluated based on three criteria, understanding of physical principles, integration of information, and clarity. Responses are expected to be succinct.

CLOSED BOOK - CLOSED NOTES

1. Precipitation is arguably the main driver of the hydrologic cycle. Based on this definition and the definition of Hyetograph and Hydrograph complete the fields illustrated in Figure 1. Where is needed, define the appropriate units. (Hints: the figure in the lower panel reflects three cases based on the intersection of land use changes. **10 points**)

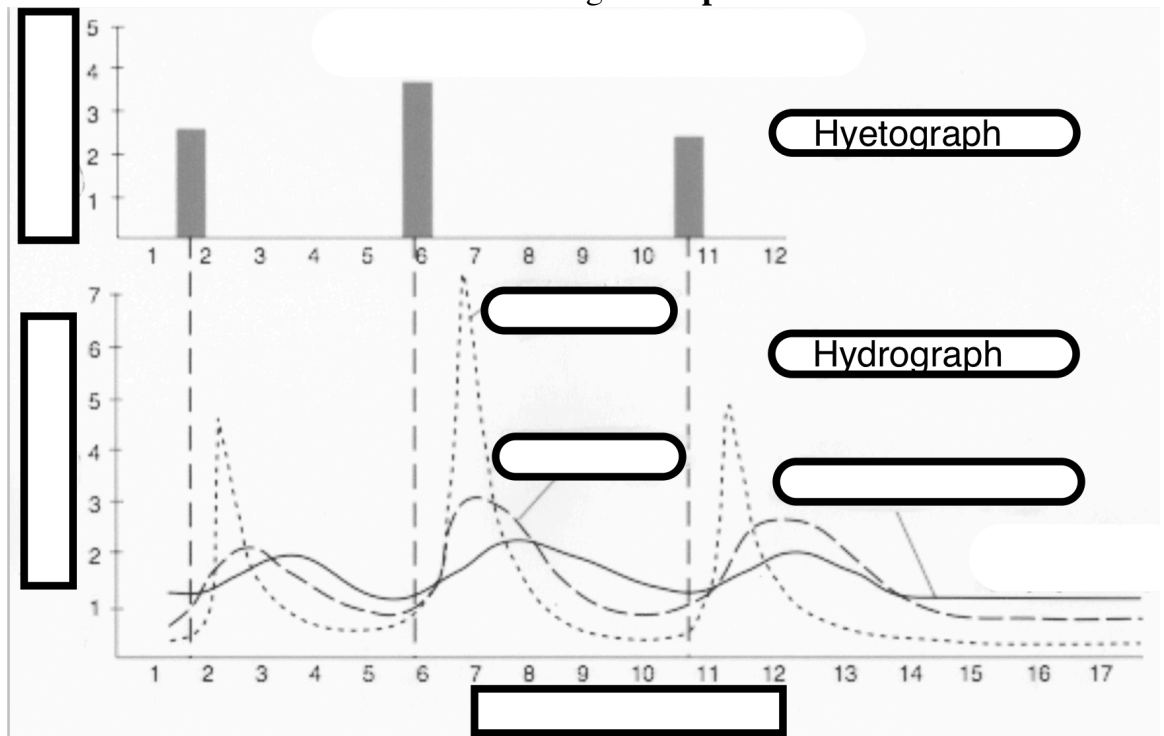

2. The main driver of the hydrologic cycle is **(5points)**:

- a. Precipitation
- b. Long-wave radiation
- c. Evapotranspiration
- d. All the above

3 Two major challenges of climate data are **(5points)**:

- e. Manage data and make them available to the public as information
- f. Simulate precipitation and wind speed
- g. Downscale minimum and maximum temperatures
- h. None of the above

4. What sources of uncertainty are involved in the simulation of land surface-atmosphere energy fluxes? **(5points)**

- a) In pyrrometers $R_n = C(T_u - T_d)$, net Radiation. Where C is a parameter expressing the rate at which the sensor is warmed or cooled by conduction and convection;
- b) T_u is Temperature of the upper surface and T_d is temperature of the lower surface in C.
- c) Simulated long-wave radiation by Land Surface Hydrology models
- d) All the above.
- e) None of the above

5. Which of these statements are true **(5points)**:

- i. ET is physical process
- j. When temperature and dew point temperature are different precipitation occurs
- k. Discharge and recharge are processes involving surface water-groundwater interactions
- l. In Frontal Uplifts Cold fronts produce moderate and long duration storms and Warm Fronts short and intense storms
- m. All the above

6. Runoff depends on watershed **(5points)**:

- n. Topography
- o. Shape
- p. Orientation
- q. Geology
- r. Soil and Land-Use
- s. All the above

7. Climate change and land use change are two big challenges for humanity. In the **FIRST** scenario aquifers in coastal areas will be affected by sea level rise in response to increasing temperatures and hydrometeorological and climate extreme events. In the **SECOND** scenario irrigation in agriculture's expansion and intensification may be the key drivers regulating groundwater use. For both scenarios (a) complement the arrows below so you can support your conclusion about the direction of the flow (as is requested in c); (b) describe and identify potential and pressure heads; (c) identify the flow direction; and (d) explain why you obtain such results on each case. **15 points**

FIRST—CLIMATE CHANGE (Sea level rise)

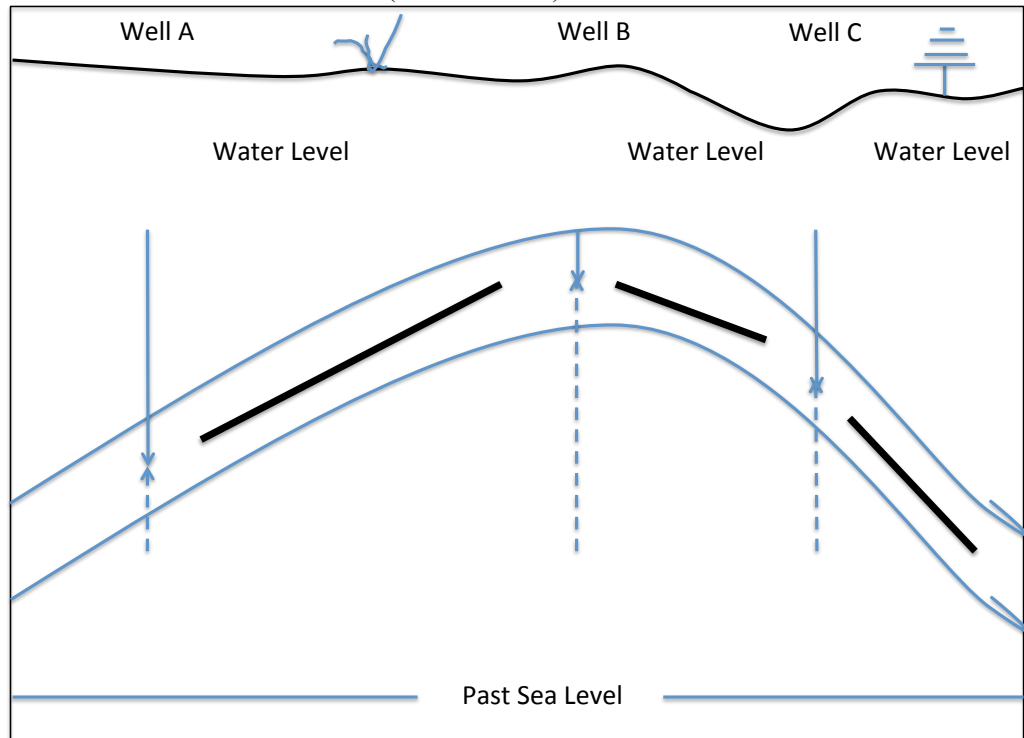

SECOND—LAND USE CHANGE (GROUNDWATER USE)

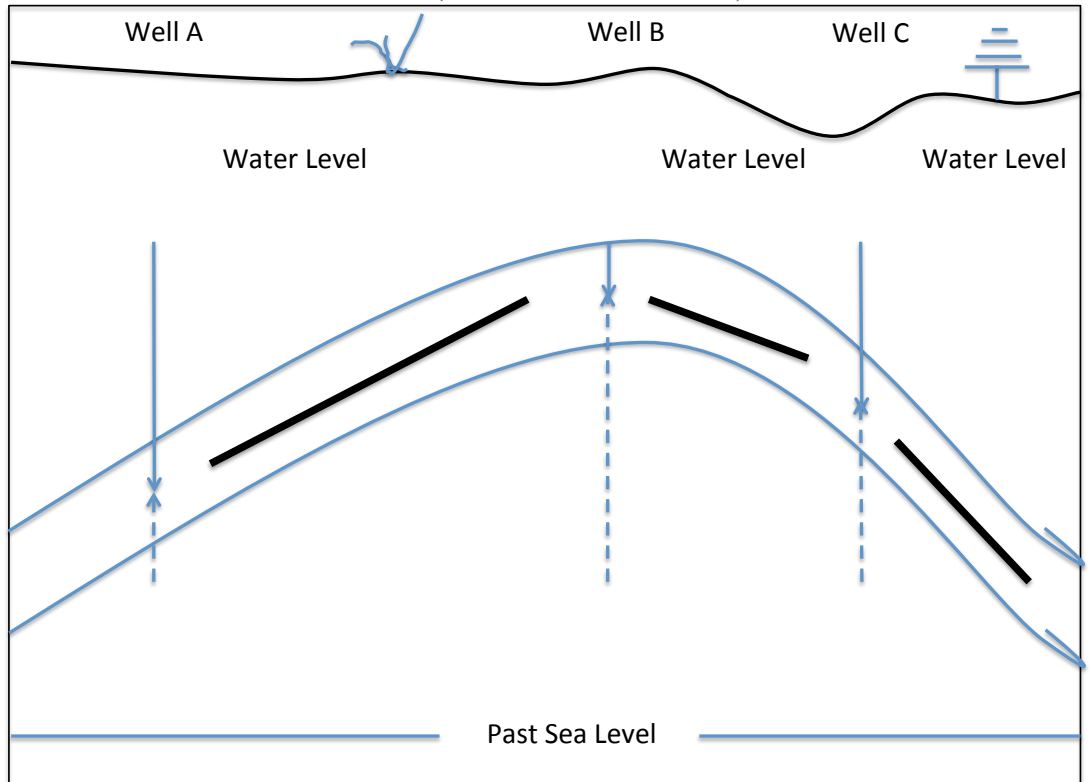

8. Provide (a) a succinct definition and three examples of variable, state variable and parameters based on a model of your choice (i.e. groundwater, vadoze zone, land surface hydrology, conceptual hydrology, or mesoscale models). (b) Now, assume you use data/information from a Global Climate Model how your answer in (a) will differ? **10 points**

9. Along the course we have emphasized a multidisciplinary perspective in the intersection between Water and Climate Systems. Below, Karamous et al. (2013) define three types of systems: Isolated, Closed, and Open. Based on the definitions below provide a “hydroclimatic example” of **two** of those systems. Examples (a) could be perceptual, procedural, or conceptual models of the hydroclimate; (b) define physical boundaries; (c) assumptions; (d) inputs, parameters, and outputs. **20 points**

- a) *Isolated system: In this kind of system, there is no interaction with the surroundings across the boundary and they could only exist in the laboratory and be used for development of some concepts.*
- b) *Closed systems: These systems are closed with respect to matter, but energy may be transferred between the system and its surroundings. On the Earth, closed systems are rare but it is often useful to treat complicated environmental systems as closed systems.*
- c) *Open systems: Both matter and energy are exchanged with the surroundings in the open system. All environmental systems are open systems and are characterized by the maintenance of structure in the face of continued throughputs of both matter and energy*

10) Modeling is criticized by some (a) scientists because of the multiple assumptions and uncertainties associated with boundary conditions and initial conditions; and (b) engineers because of does not involve designing. Based on what you have learned for this exam. Provide elements that support hydroclimatic system modeling as a strong scientific and engineering enterprise. Make your choice according to your program. **5 points**

OPEN BOOK - OPEN NOTES

11) Develop a draft of the methodology you will use in your final project.
(a) Data description; (b) Model description, including critical equations that drive your model and simulated (output) variables or state variables. For those who are using statistical approaches applied to data list the expressions that define your approach (from seasonal averages to complex spatiotemporal correlation). (c) Post-processing.

15 Points

NOTE: Although this question counts for 15 points in this midterm, additional points will be added to your final presentation, since the methodology is one of the critical points to be assessed in the final report and presentation. Use one to three figures maximum, unless you can justify more. Before submitting this question you are not allowed to exchange information with the TAs (Carlos or Daniel).

17:34

89
Good job

Name: ALESSANDRO ANARANTO

NRES/METR/BSEN 479/879
HYDROCLIMATOLOGY
Midterm Exam
April 7th, 2016

Exams are tools to evaluate our understanding as well as to continue our learning activities. The questions below are aimed to assess your understanding on Lectures, Discussions, and Labs (for the Open-Book question). Your answers will be evaluated based on three criteria, understanding of physical principles, integration of information, and clarity. Responses are expected to be succinct.

CLOSED BOOK - CLOSED NOTES

1. Precipitation is arguably the main driver of the hydrologic cycle. Based on this definition and the definition of Hyetograph and Hydrograph complete the fields illustrated in Figure 1. Where is needed, define the appropriate units. (Hints: the figure in the lower panel reflects three cases based on the intersection of land use changes. **10 points**)

10

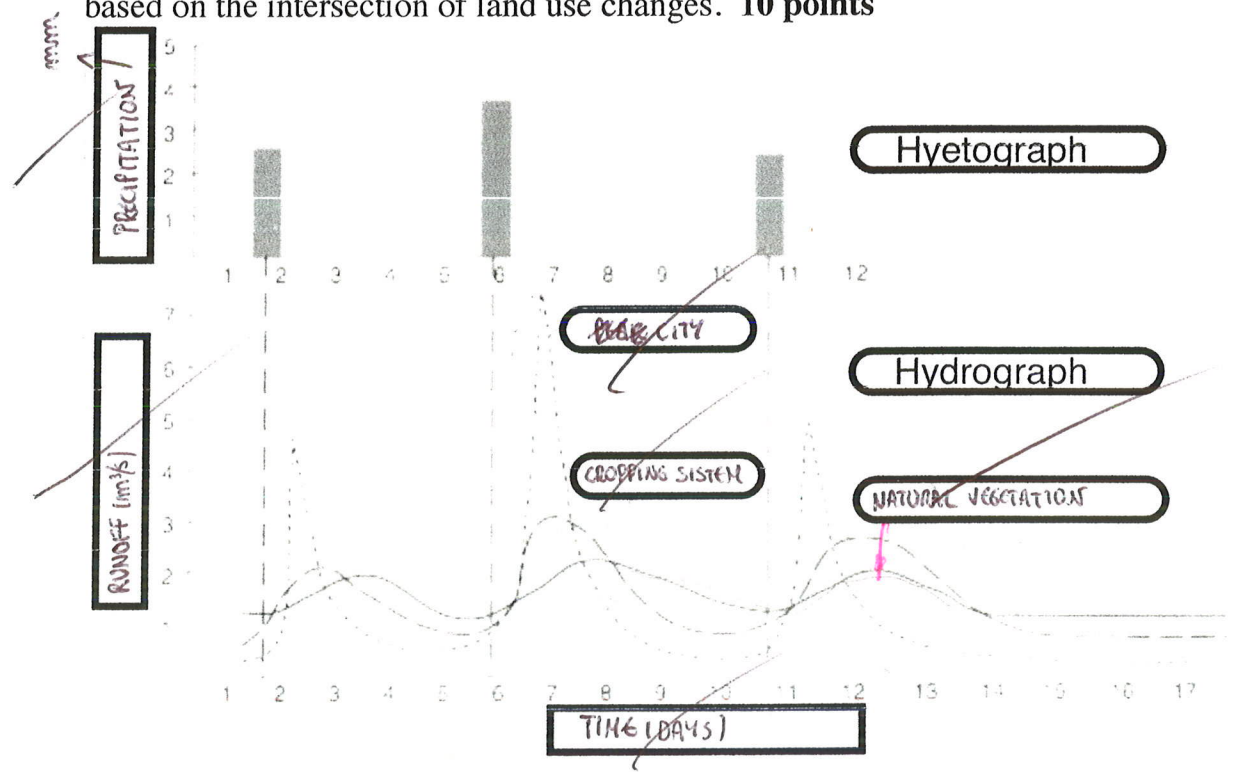

2. The main driver of the hydrologic cycle is (5points):

- a. Precipitation
- b. Long-wave radiation
- c. Evapotranspiration
- d. All the above

3. Two major challenges of climate data are (5points):

- e. Manage data and make them available to the public as information
- f. Simulate precipitation and wind speed
- g. Downscale minimum and maximum temperatures
- h. None of the above

4. What sources of uncertainty are involved in the simulation of land surface-atmosphere energy fluxes? (5points)

- a) In pyrrometers $R_n = C(T_u - T_d)$, net Radiation. Where C is a parameter expressing the rate at which the sensor is warmed or cooled by conduction and convection;
- b) T_u is Temperature of the upper surface and T_d is temperature of the lower surface in C. (THERE ARE UNCERTAINTIES IN THE MEASUREMENT)
- c) Simulated long-wave radiation by Land Surface Hydrology models
- d) All the above.
- e) None of the above

5. Which of these statements are true (5points):

- f. ET is physical process
- g. When temperature and dew point temperature are different precipitation occurs
- h. Discharge and recharge are processes involving surface water-groundwater interactions
- i. In Frontal Uplifts Cold fronts produce moderate and long duration storms and Warm Fronts short and intense storms
- m. All the above

6. Runoff depends on watershed (5points):

- n. Topography
- o. Shape
- p. Orientation
- q. Geology
- r. Soil and Land-Use
- s. All the above

7. Climate change and land use change are two big challenges for humanity. In the **FIRST** scenario aquifers in coastal areas will be affected by sea level rise in response to increasing temperatures and hydrometeorological and climate extreme events. In the **SECOND** scenario irrigation in agriculture's expansion and intensification may be the key drivers regulating groundwater use. For both scenarios (a) complement the arrows below so you can support your conclusion about the direction of the flow (as is requested in c); (b) describe and identify potential and pressure heads; (c) identify the flow direction; and (d) explain why you obtain such results on each case. **15 points**

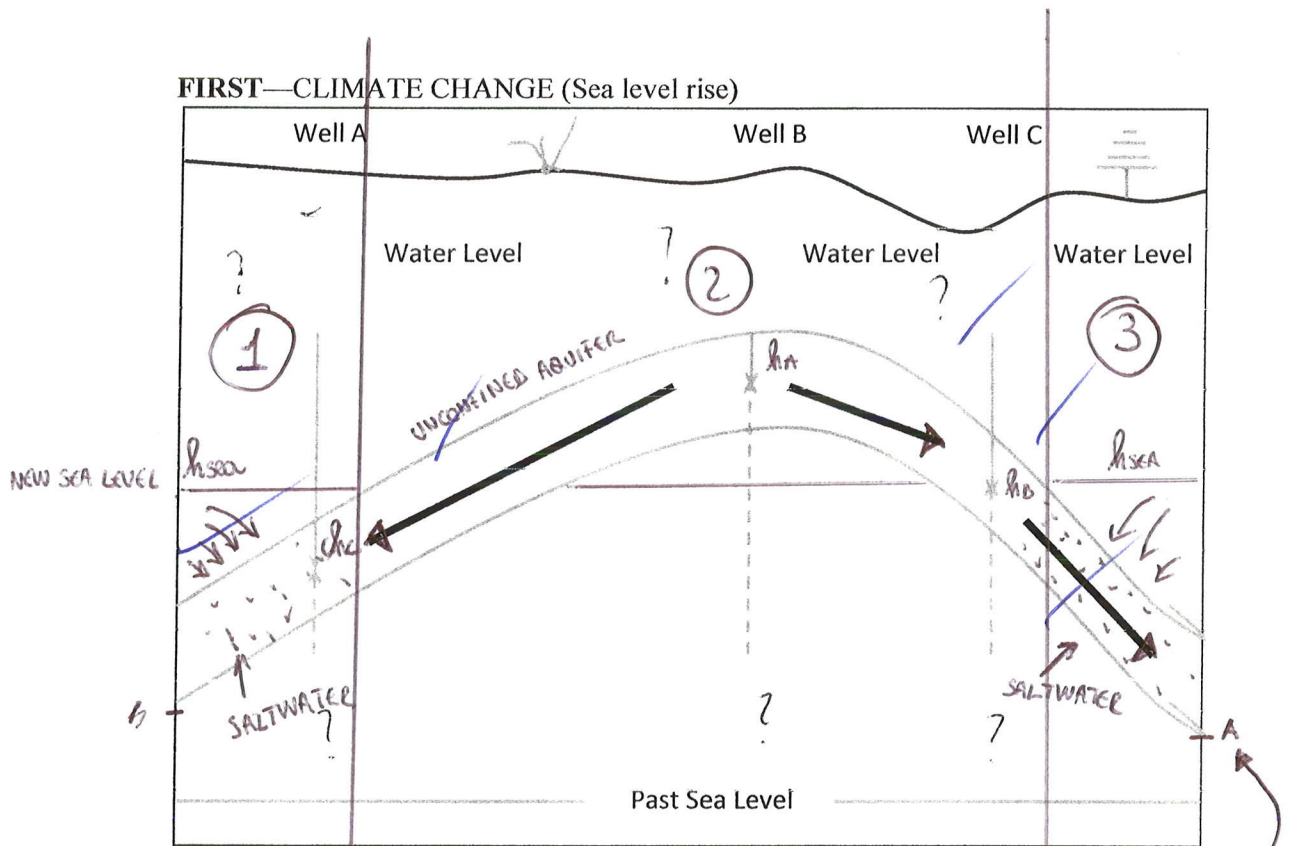

IF THE SEA LEVEL RISES ABOVE THE LEVEL A, THERE IS AN INTERACTION BETWEEN SEA WATER AND GROUNDWATER. IN PARTICULAR, THE POTENTIOMETRIC SURFACE OF THE SEA IS REPRESENTED BY THE SEA FREE SURFACE. IF THE AQUIFER IS UNCONFINED, THE POTENTIOMETRIC SURFACE IS STILL REPRESENTED BY THE AQUIFER FREE SURFACE. ^(h_a, h_b, h_c) THEREFORE THE FLOW DIRECTION IS REPRESENTED BY THE ARROWS. HOWEVER, IN REGION ① AND ③ THE SEA ~~END~~ HEAD IS HIGHER THAN THE AQUIFER HEAD. THEREFORE SEA IS ENTERING INTO THE AQUIFER. THIS PHENOMENON IS CALLED "SALTWATER" INTRUSIONS".
WATER

FROM THIS MOMENT ON, JUST WATER IN REGION 2 MIGHT BE CONSIDERED FRESHWATER.

SECOND—LAND USE CHANGE (GROUNDWATER USE)

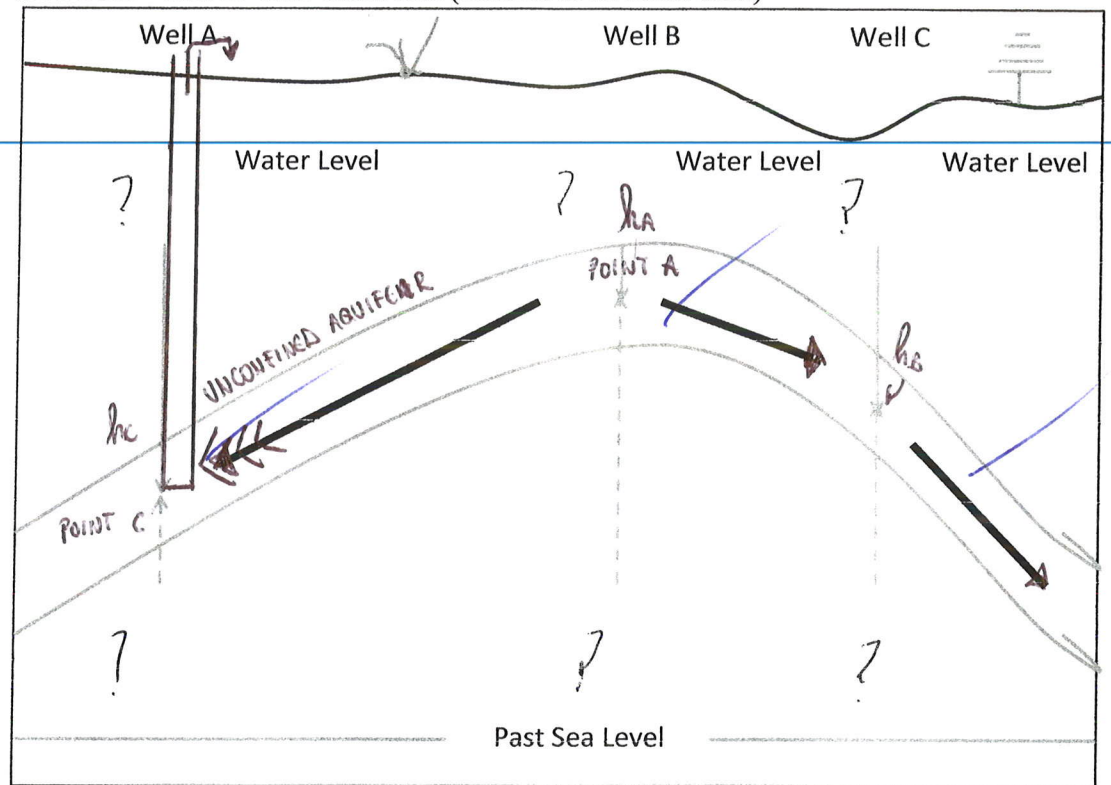

WE DECIDED TO CONSTRUCT A WELL IN POINT C (WELL A).

THE HYDRAULIC HEAD h IS DEFINED AS: $h = z + \frac{p}{\gamma}$, WHERE z IS THE GEODETIC HEIGHT, p IS THE PRESSURE OF THE ABOVE WATER COLUMN AND γ IS THE WATER DENSITY SPECIFIC WEIGHT. SINCE THE AQUIFER IS UNCONFINED,

$h = z$ ($\frac{p}{\gamma} = 0 \rightarrow \frac{p}{\gamma} = 0$). BY PUMPING OUT WATER, THE ENERGY CONTENT IN h_C (IN CORRESPONDENCE

OF THE WELL) IS DECREASED.

THEREFORE, ^{SINCE} THE FLOW EQUATION (DARCI'S LAW) STATES THAT $q = -K \frac{\partial h}{\partial L}$, AND SINCE $\frac{\partial h}{\partial L}$ INCREASES IN ABSOLUTE

VALUE BETWEEN A AND C, THE MAGNITUDE OF THE FLOW _A WILL INCREASE AS WELL, AS INDICATED BY GOING FROM A TO C

THE MULTIPLE ARROWS.

8. Provide (a) a succinct definition and three examples of variable, state variable and parameters based on a model of your choice (i.e. groundwater, vadoze zone, land surface hydrology, conceptual hydrology, or mesoscale models). (b) Now, assume you use data/information from a Global Climate Model how your answer in (a) will differ? 10 points

~~GROUNSWATER MODEL: LAPLACE DISCRETIZA~~

ARTIFICIAL

NATURAL LAKE MODEL: $S_{t+\Delta t} = S_t + P_{t+\Delta t} - R_{t+\Delta t} - \alpha \Delta T_{t+\Delta t}$ (A)

THE STORAGE AT TIME $T+\Delta t$ ($S_{t+\Delta t}$) IS EQUAL TO STORAGE AT t , PLUS PRECIPITATION, MINUS RELEASE, MINUS EVAPORATION. SINCE WE NOT HAVE EVAPORATION, WE USE α (PARAMETER) = TEMPERATURE AS A PROXY.

STORAGE: STATE VARIABLE. ITS CURRENT VALUE IS DEPENDING ON ITS PAST. THEREFORE, IN MODELING THE BEHAVIOR OF A SYSTEM IS IMPORTANT TO HAVE A MEMORY OF THE STATE'S PREVIOUS VALUE. IT HAS THEREFORE AN AUTOREGRESSIVE COMPONENT, AND DESCRIBES THE STATE OF A SYSTEM. IT IS MODELLED AS GENERALLY

NEW VALUE = PREVIOUS + INPUTS - OUTPUTS

PRECIPITATION: VARIABLE. IT IS AN INPUT TO THE SYSTEM, AND DOES NOT HAVE AN AUTOREGRESSIVE COMPONENT. ~~WHICH DEPENDS~~ IT ENTERS - EXIT THE SYSTEM AND AFFECTS ITS STATE.

α : PARAMETER EXPRESSES A DEGREE TO WHICH STATE AND INPUT/OUTPUT ARE RELATED. IT IS GENERALLY ESTABLISHED EMPIRICALLY, OR BASED ON LABORATORY EXPERIMENT. MAY DEPEND ON OTHER VARIABLES (EX: HYDRAULIC CONDUCTIVITY IN GW SYSTEMS), OR BE RESULTS OF STATISTICAL REGRESSION.

β - PRECIPITATION IN CASE (A) MIGHT BE A MEASURED VARIABLE. IF WE INTEGRATE THE MODEL DESCRIBED IN (A) INTO A GLOBAL CLIMATE MODEL, PRECIPITATION IS A MODEL-COMPUTED VARIABLE, RESULTING FROM A CONVECTIVE/OROGRAPHIC/FRONTAL LIFT OF AIR. ACCORDING TO THE ~~ADIBATIC~~ ~~GRADIENT~~ TEMPERATURE CHANGE WITH HEIGHT, THE AIR PRESSURE REACHES SATURATION AT A CERTAIN HEIGHT, AND THEN VAPOUR CONDENSATION MAY OCCUR ON CCs. THEREFORE, P WILL BE A FUNCTION OF ATMOSPHERIC/LAND SURFACE CONDITIONS.

9. Along the course we have emphasized a multidisciplinary perspective in the intersection between Water and Climate Systems. Below, Karamous et al. (2013) define three types of systems: Isolated, Closed, and Open. Based on the definitions below provide a "hydroclimatic example" of two of those systems. Examples (a) could be perceptual, procedural, or conceptual models of the hydroclimate; (b) define physical boundaries; (c) assumptions; (d) inputs, parameters, and outputs. **20 points**

- a) *Isolated system: In this kind of system, there is no interaction with the surroundings across the boundary and they could only exist in the laboratory and be used for development of some concepts.*
- b) *Closed systems: These systems are closed with respect to matter, but energy may be transferred between the system and its surroundings. On the Earth, closed systems are rare but it is often useful to treat complicated environmental systems as closed systems.*
- c) *Open systems: Both matter and energy are exchanged with the surroundings in the open system. All environmental systems are open systems and are characterized by the maintenance of structure in the face of continued throughputs of both matter and energy*

20

OPEN SYSTEMS: (CROP FIELD)

MASS EXCHANGE

$$(1) \quad SWC_{E+1} = SWC_E + P - ET + \alpha R + CR - DP \rightarrow \text{DEEP PERCOLATION}$$

\uparrow WATER TABLE RISE
 \downarrow CAPILLARY RISE

ENERGY

$$(2) \quad R_{of} = LE + H + G$$

A CROP FIELD EXCHANGES BOTH MASS AND ENERGY WITH THE SURROUNDING. MASS BALANCE DESCRIBES THE CHANGE IN STORAGE (SOIL WATER) BY MEANS OF INPUT (PRECIPITATION, αR = PORTIONS OF RUNOFF THAT INFILTRATES, WATER TABLE/CAPILLARY RISE) OR OUTPUT (DEEP PERCOLATION, EVAPOTRANSPIRATION) ~~WATER~~. WATER INPUT/OUTPUT ARE THE MASS EXCHANGE WITH THE SURROUNDING. THE EQUATION 2 DESCRIBES THE ENERGY EXCHANGE BY MEANS OF LATENT, SENSIBLE HEAT AND RADIATION

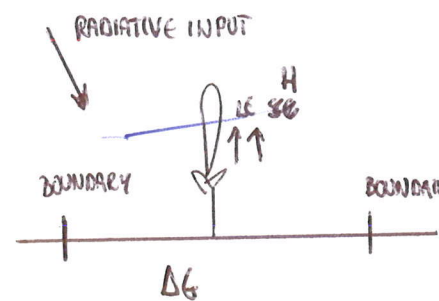
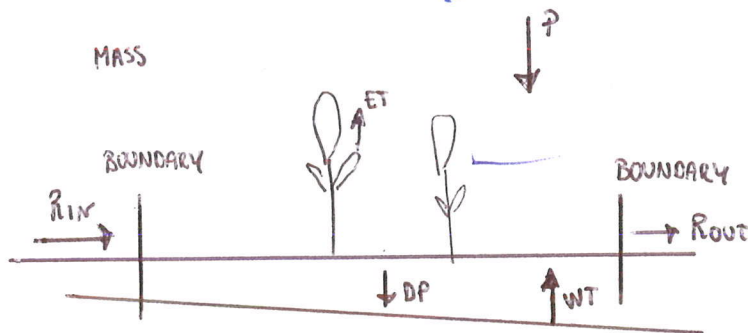

CLOSED SYSTEM: GREENHOUSE

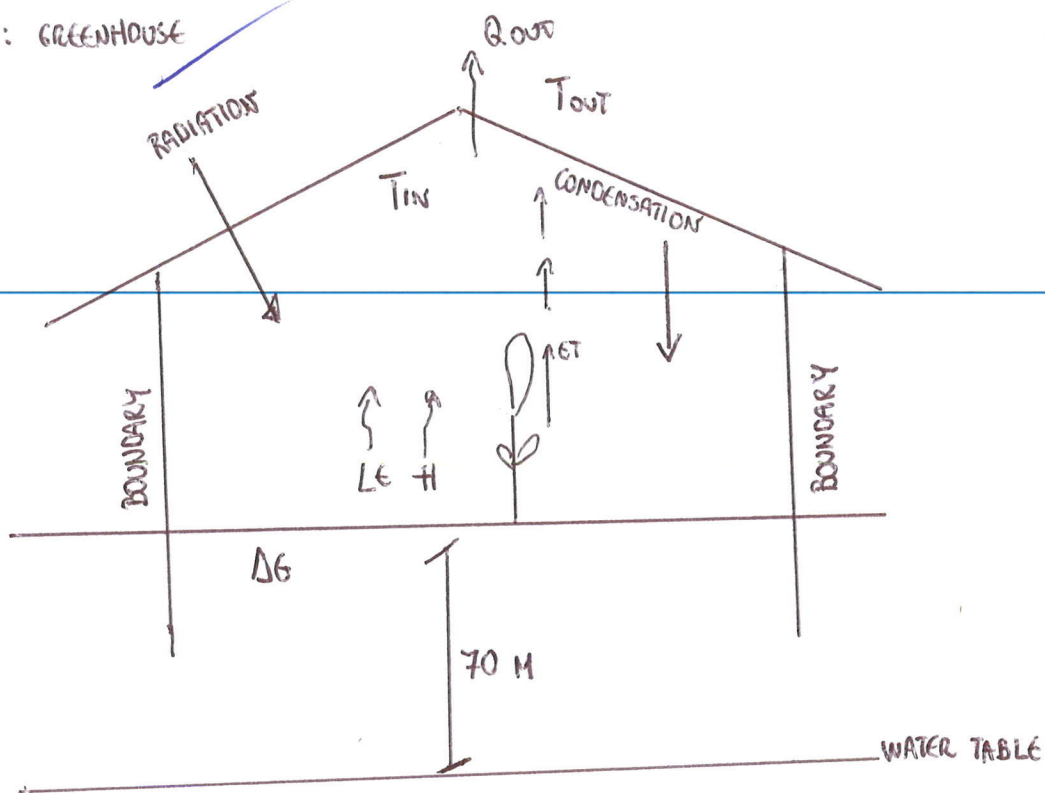

70

MASS BALANCE: STORAGE = -ET + CONDENSATION. They BOTH HAPPENS INSIDE THE DOMAIN. CHANGE IN SOIL MOISTURE ARE DUE TO EVAPORATION ~~FROM PLANT~~. THE WATER VAPOUR CONDENSATE INSIDE THE GREENHOUSE AND FALL AGAIN. NO MASS EXCHANGE WITH SURROUNDING.

ENERGY: SOLAR RADIATION COMES IN. INCREASES THE TEMPERATURE. WATER IS HEATED, SENSIBLE HEAT IS RELEASED. $\Delta\theta$ INCREASES (SOIL ENERGY)

WATER BECOMES VAPOUR (LATENT HEAT IS RELEASED), PART OF THE ENERGY IS RELEASED AS THERMAL ENERGY (~~Q_out~~ Q_out) DUE TO THE HIGHER TEMPERATURE INSIDE THE GREENHOUSE

SUMMARY

	OPEN SYSTEM	CLOSED SYSTEM
BOUNDARY	FIELD BOUNDARY	GREENHOUSE BOUNDARY
MASS INPUT	P/P, PRECIPITATION, WATER TABLE RISE, RUNOFF INFILTRATION, IRRIGATION...	X
MASS OUTPUT	ET, DEEP PERCOLATION	X
PARAMETERS	α = PORTION OF RUNOFF THAT INFILTRATES	X
E INPUT	SOLAR RADIATION	SOLAR RADIATION
E OUTPUT	LE, H	$Q = \alpha \rho c_p \Delta T = \alpha (T_{in} - T_{out})$
ASSUMPTION	X	WATER TABLE IS FAR, NO WINDOWS, NO HOLES

10) Modeling is criticized by some (a) scientists because of the multiple assumptions and uncertainties associated with boundary conditions and initial conditions; and (b) engineers because of does not involve designing. Based on what you have learned for this exam. Provide elements that support hydroclimatic system modeling as a strong scientific and engineering enterprise. Make your choice according to your program. **5 points**

~~As answer to scientists~~ UNCERTAINTIES ASSOCIATED WITH INITIAL AND BOUNDARY CONDITIONS MIGHT BE ADDRESSED BY RUNNING MULTIPLE MODELS WITH DIFFERENT INITIAL/BOUNDARY CONDITIONS, THEN PERFORM AN ENSEMBLE. SUCH AN ENSEMBLE WILL BE COUPLED WITH UNCERTAINTIES, BUT OF COURSE, SUCH UNCERTAINTY IS A MEASURE OF HOW HOW WIDE CAN BE THE RANGE OF VARIATION OF A CERTAIN VARIABLE PROJECTED IN TIME. MOREOVER, HYDROCLIMATIC MODELING OUTPUT, EVEN IF COUPLED WITH UNCERTAINTIES, MAY SERVE TO DECISION MAKERS AS AN INFORMATION FRAMEWORK FOR A SPECIFIC SCENARIO.

MOREOVER, FINALLY, THE MODEL ITSELF AND ITS IMPLEMENTATION REQUIRES THE KNOWLEDGE OF A SYSTEM AND THE PROCESSES INVOLVED. THEREFORE, IMPLEMENTING A MODEL ~~REQUIRES~~ AND BRINGS ~~MODEL KNOWLEDGE TO EXIST~~ WILL ALLOW TO GET IN TOUCH WITH THE SYSTEM, AND ~~USE~~ FROM THE SENSITIVITY ANALYSIS WILL BE POSSIBLE TO UNDERSTAND WHICH VARIABLE/PARAMETER AFFECTS THE BEHAVIOR OF A SYSTEM.

Appendix 8

NRES- 879 HYDROCLIMATOLOGY
SIMULATION OF SOIL MOISTURE AND EVAPOTRANSPIRATION FOR
THE STATE OF NEBRASKA USING VARIABLE INFILTRATION
CAPACITY MODEL

ABSTRACT

Soil moisture is a key variable in controlling the exchange of water and heat energy between the land surface and the atmosphere through evaporation and plant transpiration. As a result, soil moisture plays an important role in the development of weather patterns and the production of precipitation. Despite the importance of soil moisture information, continuous measurements of surface soil moisture with global coverage is nonexistent. This study focuses on simulating the soil moisture, Evapotranspiration (ET) and surface temperature using Variable Infiltration Capacity (VIC) land surface macroscale hydrology model for the state of Nebraska (NE), USA for a period of 1 January 1960 to 31 December 2013. The model is applied to 5544 grids in NE with a resolution 0.0625 X 0.0625 degrees. The total area of the domain is 200520 Km². In-situ soil moisture, ET and surface temperature measurements from four sites in the state are used for model validation. The results indicate that the simulated soil moisture showed an increasing trend from northwest to southeast in all soil moisture layers. ET also showed an increasing trend from west to east of the state. VIC performs well for the first soil moisture layer, however correlation with in-situ soil moisture decreased with depth.

SIMULATION OF SOIL MOISTURE AND EVAPOTRANSPIRATION FOR THE STATE OF NEBRASKA USING VARIABLE INFILTRATION CAPACITY MODEL

NRES- 879 HYDROCLIMATOLOGY

Vasudha Sharma

Soil moisture

- ▶ Key state variable in climate and terrestrial branch of hydrological cycle
- ▶ Controls hydrological processes for both storm and interstorm periods:
 - ▶ Storm periods : Controls the proportion of precipitation that percolates in the soil, evaporates from the land and becomes runoff.
 - ▶ Interstorm periods: determines whether the soil column can meet the atmospheric demand for moisture; either at the surface (bare soil evaporation) or in the root zone (transpiration) and it thus affects the partitioning between latent and sensible heat flux
- ▶ Important role in the development of weather patterns and the production of precipitation
- ▶ Hydrological variable linked to plant performance during the growing season
- ▶ Offers useful perspective on influence of changes in precipitation on vegetation
- ▶ Large-scale and long sequences of measured soil moisture data are difficult to acquire
- ▶ But can be simulated by using land surface hydrological models based on meteorological data

Evapotranspiration (ET)

- ▶ One of the most important components in determining the water use efficiency in agriculture
- ▶ Quantification of ET is important in determining the net crop irrigation requirement
- ▶ Decision making : Allocation and management of water resources

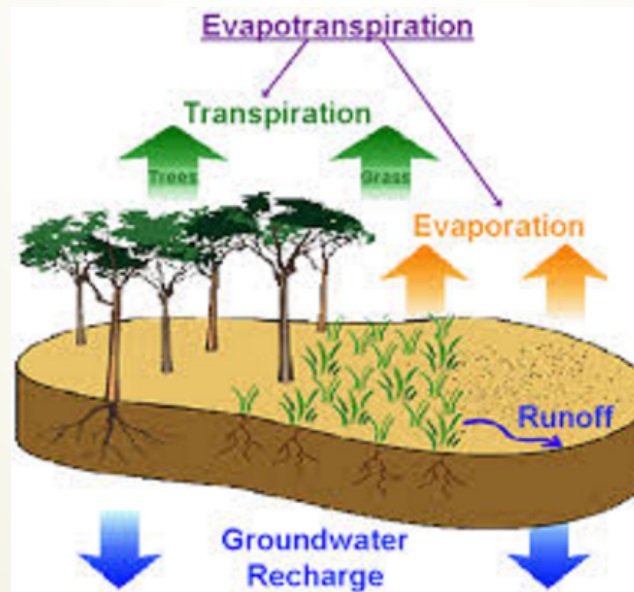

Variable infiltration capacity (VIC) Model

- ▶ Grid-based land surface representation – Grid cells do not interact with each other
- ▶ Simulates land-surface atmosphere exchanges of moisture and energy
- ▶ 2-layer soil vegetation model designed to be dynamically coupled to GCMs or weather models (e.g. at 0.5 degree lat-lon resolution)
- ▶ Parameterized infiltration and base flow schemes
- ▶ Single layer energy balance snow model
- ▶ Physically-based vegetation model including canopy effects
- ▶ Physically-based evaporation based on the Penman/Monteith approach

Liang et al. 1994

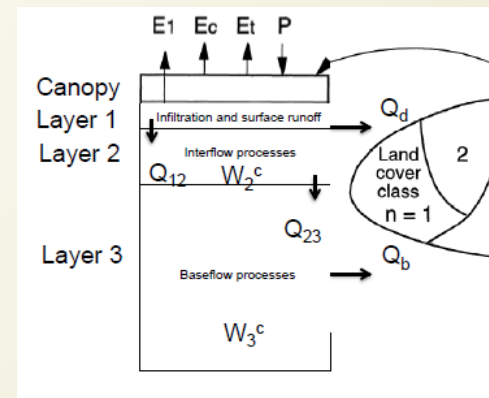



Objective

- ▶ To simulate the spatial distribution of soil moisture and ET from 1961 to 2013 for the state of Nebraska.
- ▶ To verify simulated soil moisture, ET and surface temperature by in-situ measured values for four locations in the state.

Study area

- ▶ The study is conducted for the entire state of Nebraska
- ▶ The major river basins in the state are the Missouri, Niobrara, Platte and Republican River basins
- ▶ The soil moisture and other fluxes are simulated on daily time step
- ▶ resolution of 0.0625 X 0.0625 degrees
- ▶ 5544 grid cells

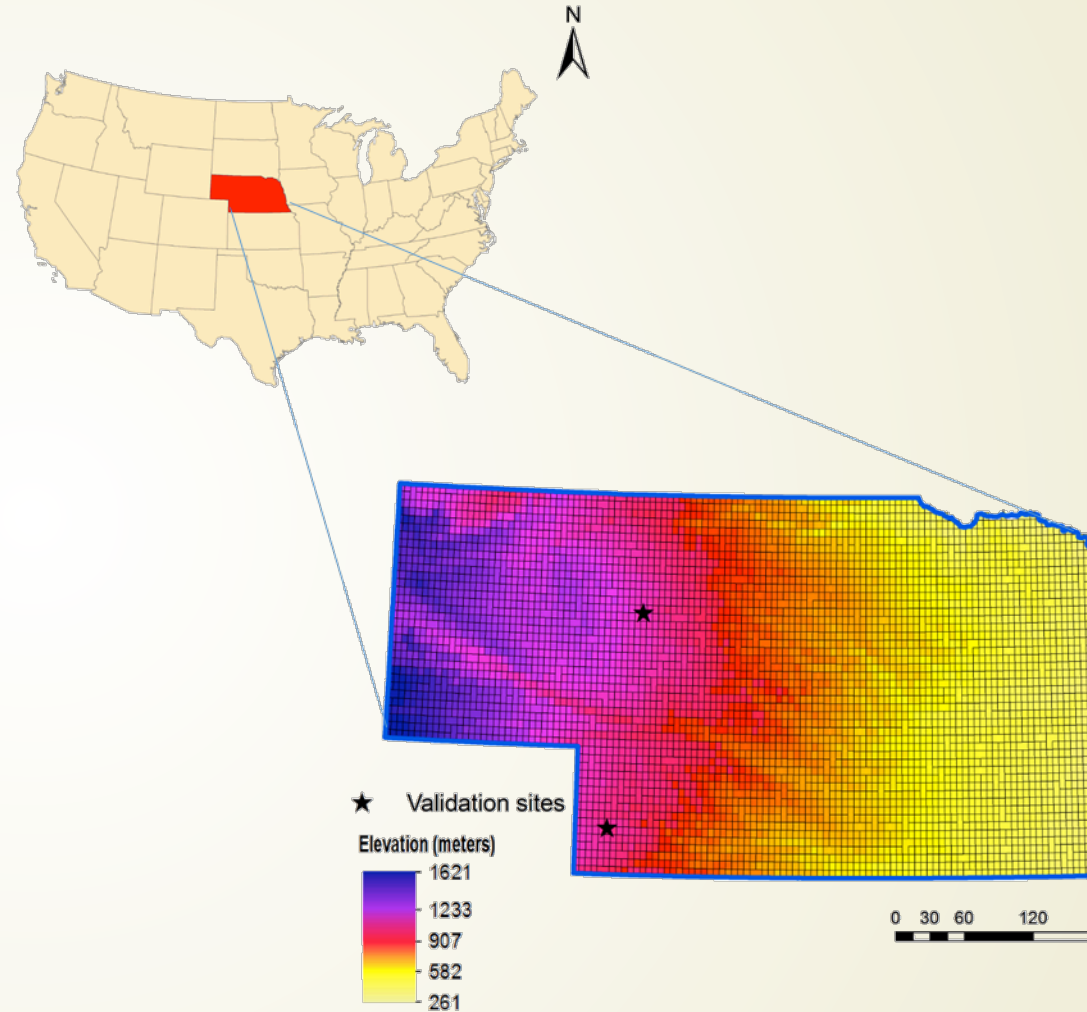

Validation sites and data

- Four validation sites
- Ameriflux sites: Hourly data of soil moisture (10 cm and 25 cm depth), ET and surface temperature
 - Sandhill (42.0693, -101.4072) (2004-2009)
 - Mead (41.1649, -96.4701) (2001-2013)
- Soil Climate Analysis Network – NRCS (SCAN) sites: Daily soil moisture (10 cm, 50 cm and 100 cm)
 - Johnson farm (40.37, -101.72) (2005-2013)
 - Roger farm (40.85, -96.47) (1996-2013)

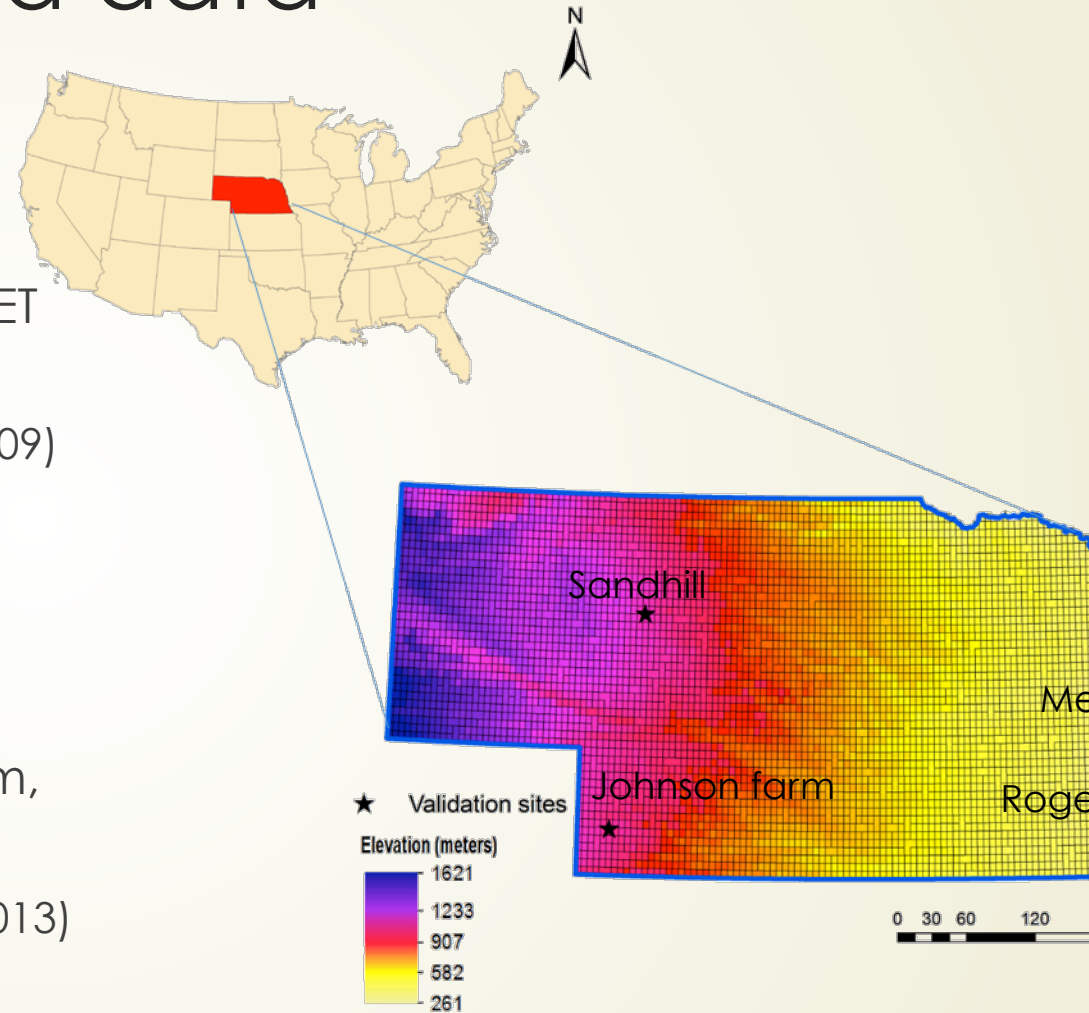

VIC Modelling

➤ Steps involved in modelling land surface using VIC model:

➤ Delineating the Area of interest

➤ VIC input files:

- **Global parameters File:** points VIC to the locations of the other input/output files and sets parameters that govern the simulation
- **Meteorological forcing Files:** daily or sub-daily timeseries of meteorological variables as inputs. gridded or point station data or reanalysis fields.
- **Soil parameters File:** lat/lon, soil texture and other characteristics.
- **Vegetation Library File:** available land cover types
- **Vegetation parameter File:** Landcover types, fractional areas, rooting depths, and seasonal LAIs of the various landcover files within each grid cell

➤ Running VIC

➤ Output files

Parametrization

- ▶ Default depth of soil moisture in VIC model was: 0.10m , 0.20m and 0.50m
- ▶ Parameters for soil depth were changed in the model in order to make them same as the observation data depths.
- ▶ For Sandhill and Mead site, VIC model was ran for the depths of 0.1m, 0.15m and 0.50m.
- ▶ For Johnson and Roger farm, VIC model was ran for the depths of 0.1m, 0.40m and 0.50m.

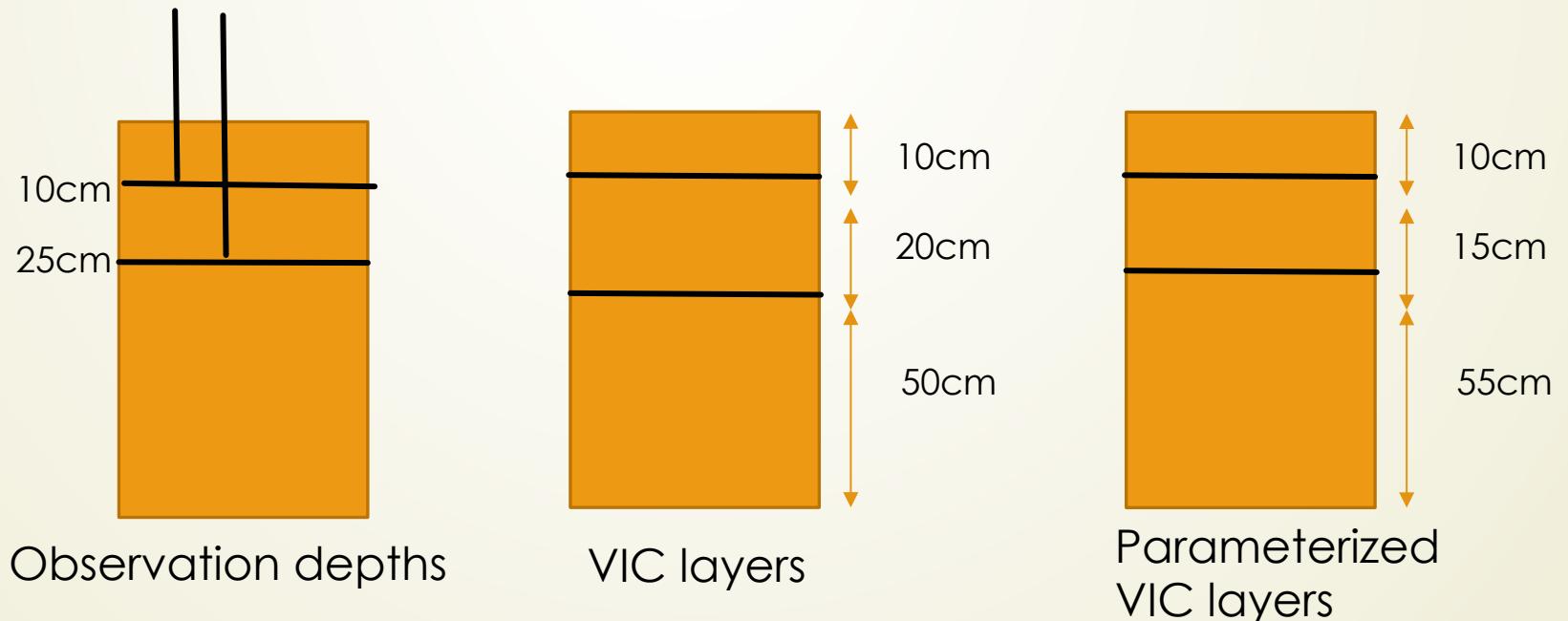

Comparison of simulated vs measured

- ▶ Rationality of simulated results were verified by contrasting the simulated anomalies with observed.
- ▶ Anomaly was computed as:
 - ▶ $y_i = x_i - \bar{x}_i$
 - ▶ Where, x_i and \bar{x}_i represent the current value and its climatology, respectively.
- ▶ Correlation coefficients of each layer at four stations were calculated.

Spatial distribution - Soil moisture

- ▶ Spatial distribution of Soil moisture in three layers (0.10m, 0.20m and 0.50m) for the month of MAY (1960-2013)

(a) 0-10 cm

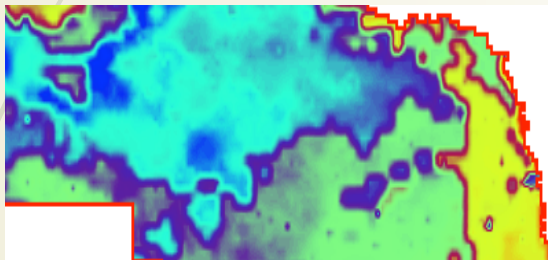

(b) 10- 30 cm

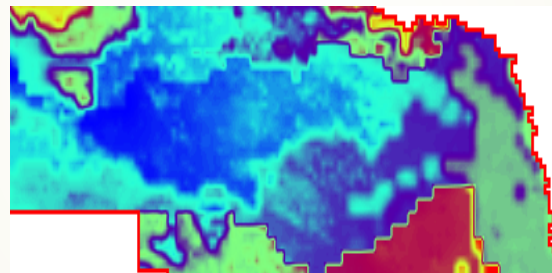

(c) 30-80 cm

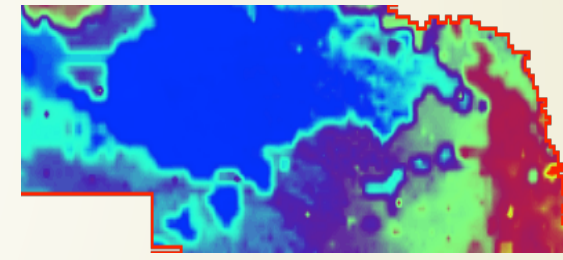

(d) Precipitation MAY (1960-2013)

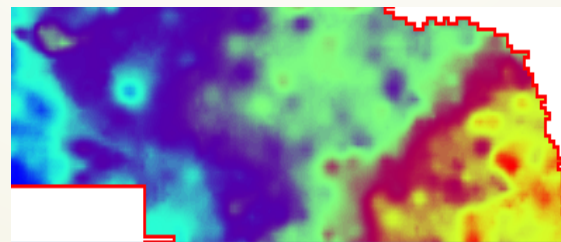

Spatial distribution – ET (1960-2013)

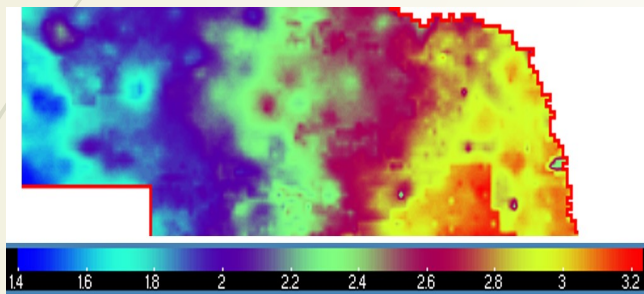

(a) May

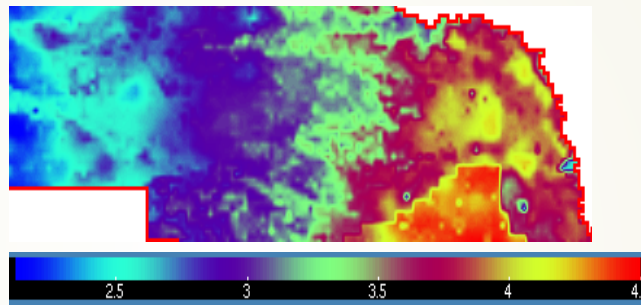

(b) June

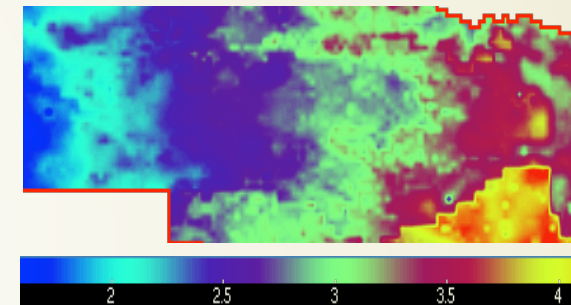

(c) July

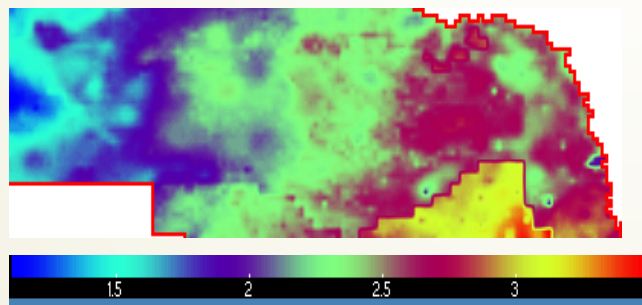

(d) August

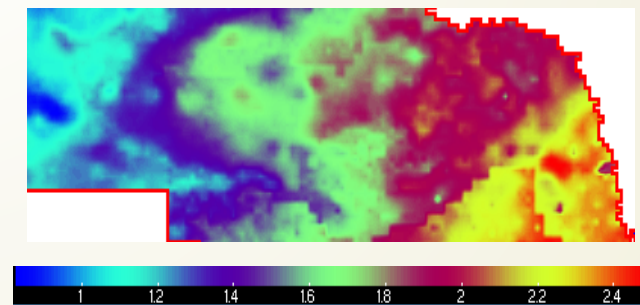

(e) Sep

mm/day

Validation results – Soil moisture

► Sandhills

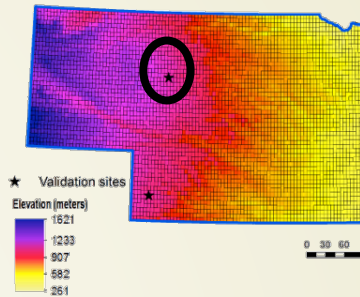
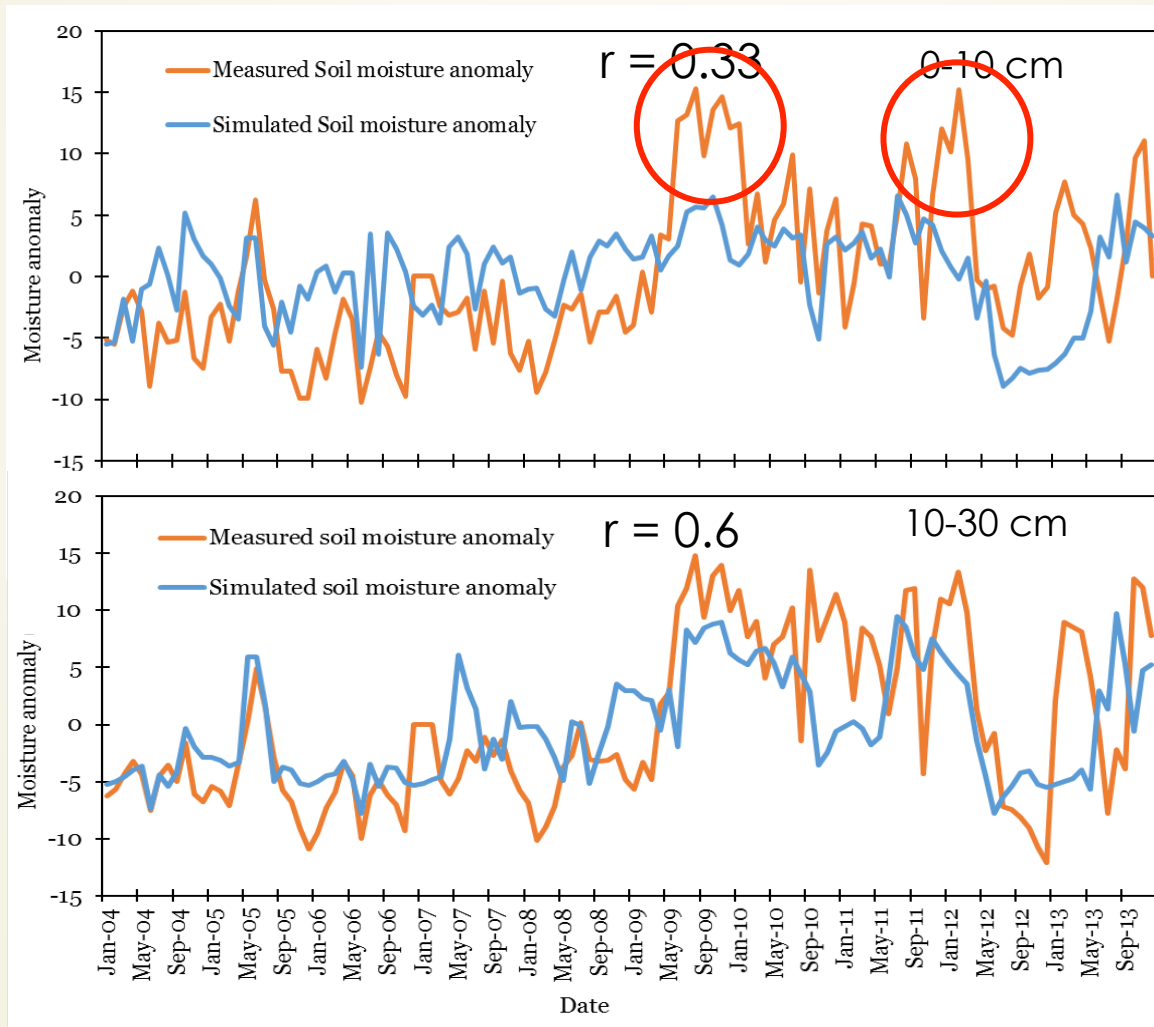

Before parameterization

Moisture units are %

Validation results – Soil moisture

► Sandhills

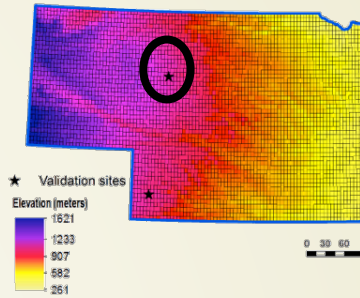
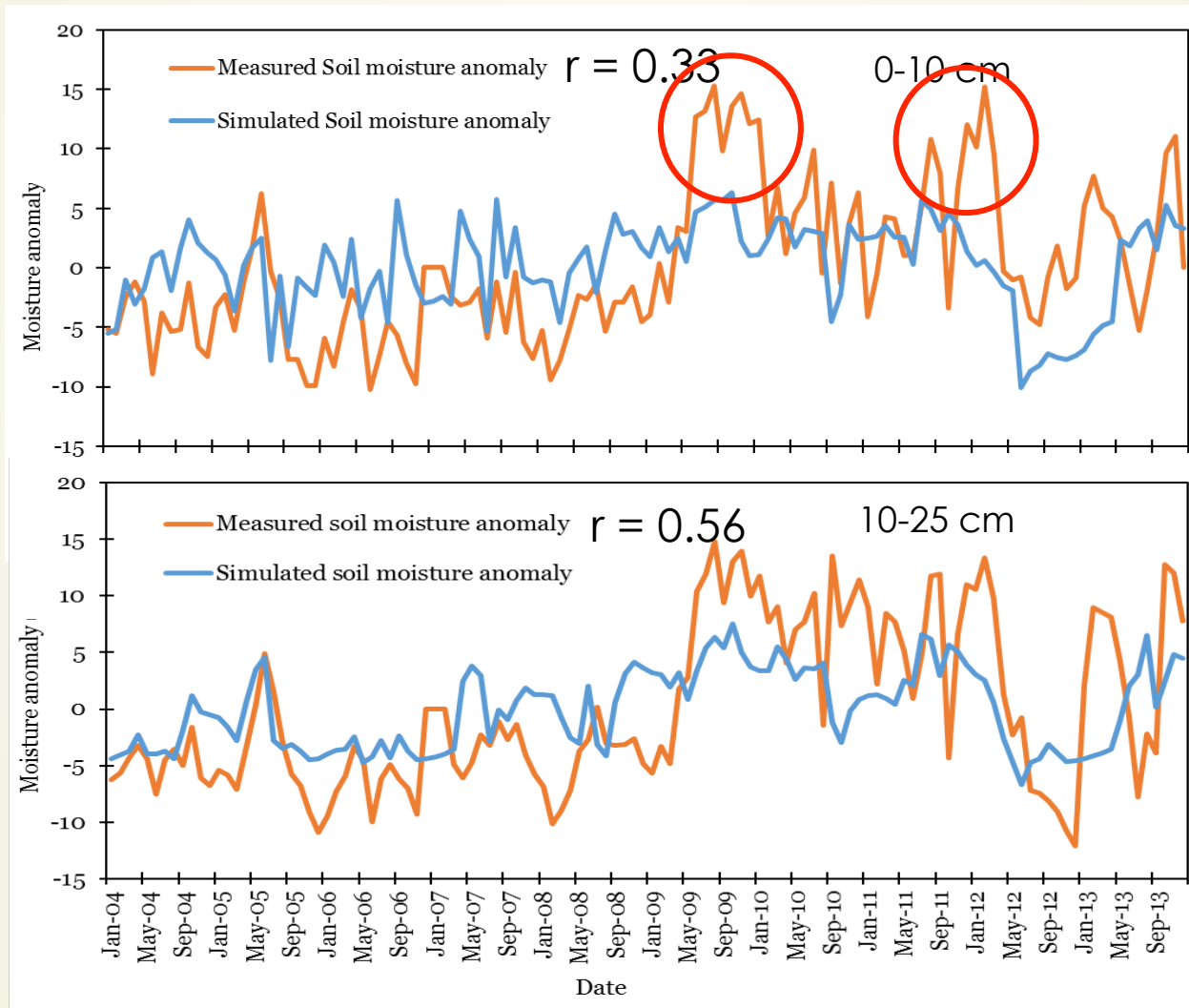

After parameterization

Moisture units are %

Validation results – Soil moisture

Mead

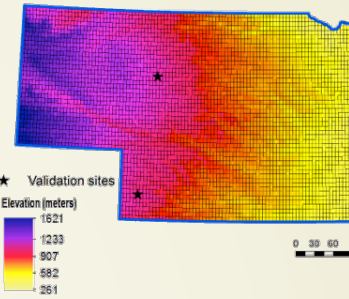
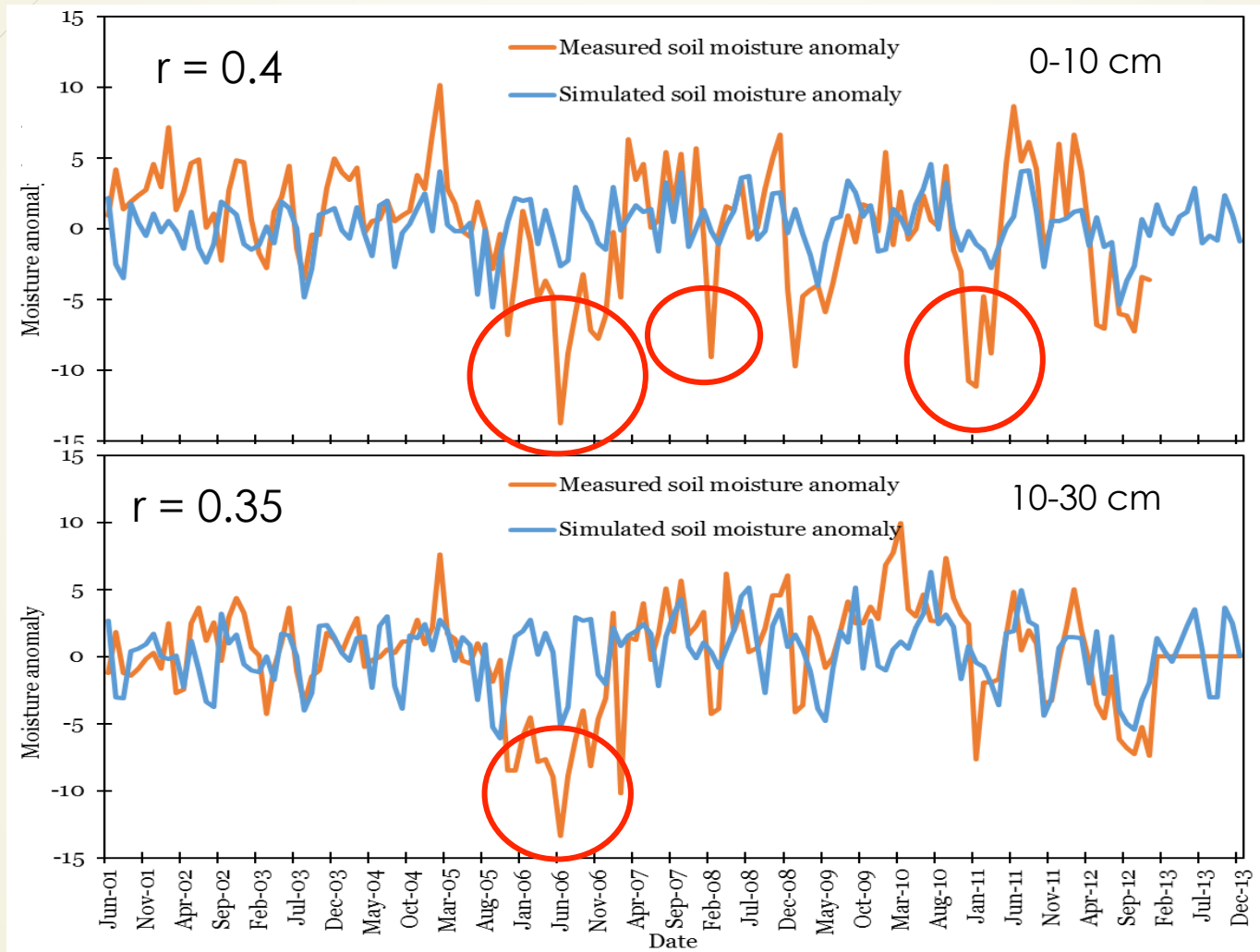

Before parameterization

Moisture units are %

Validation results – Soil moisture

Mead

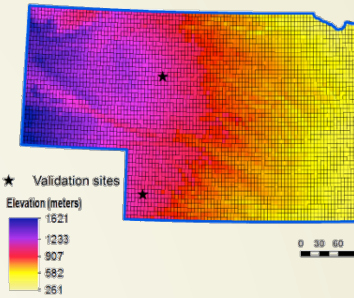
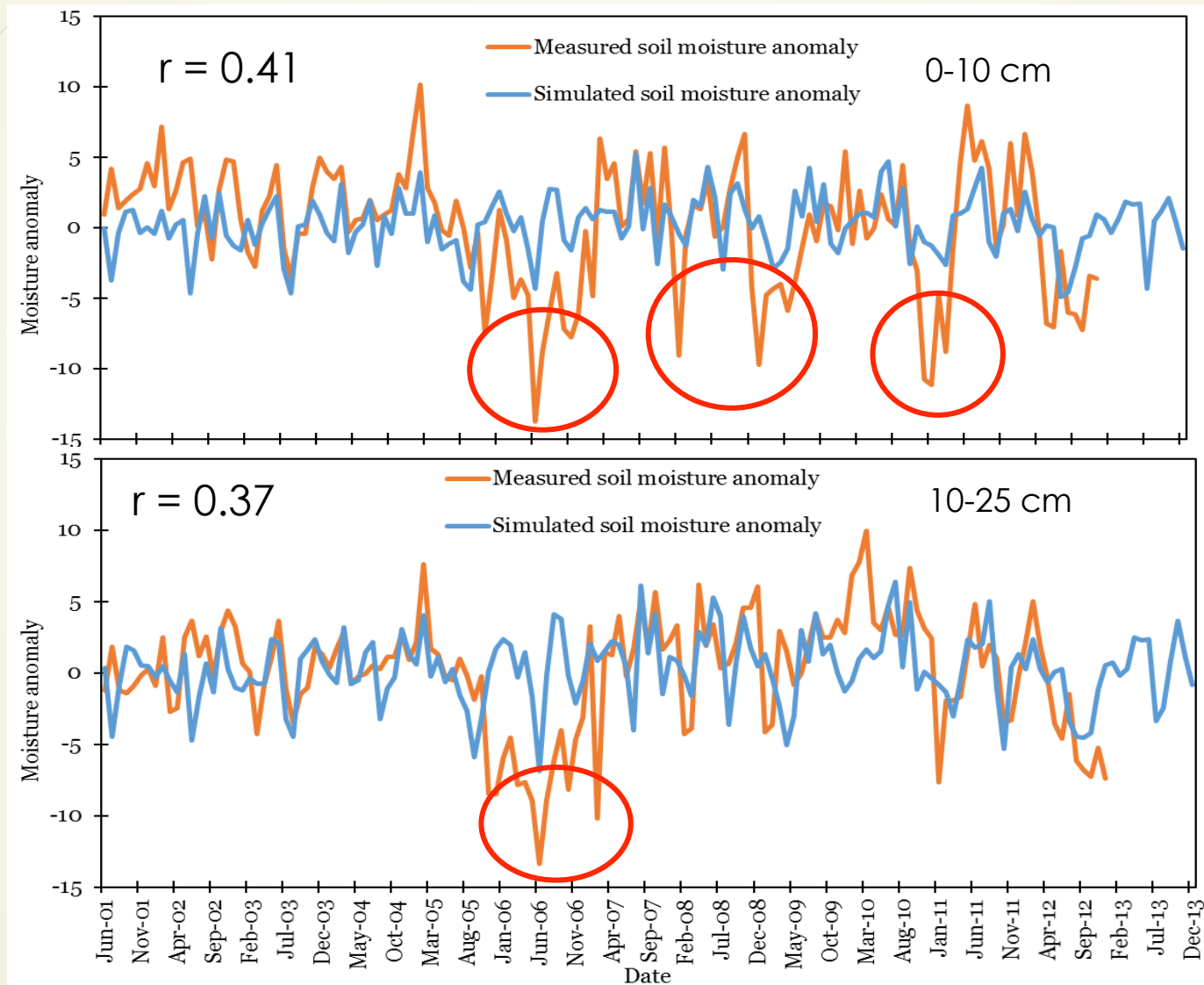

After parameterization

Moisture units are %

Validation results – Soil moisture

Roger Farm

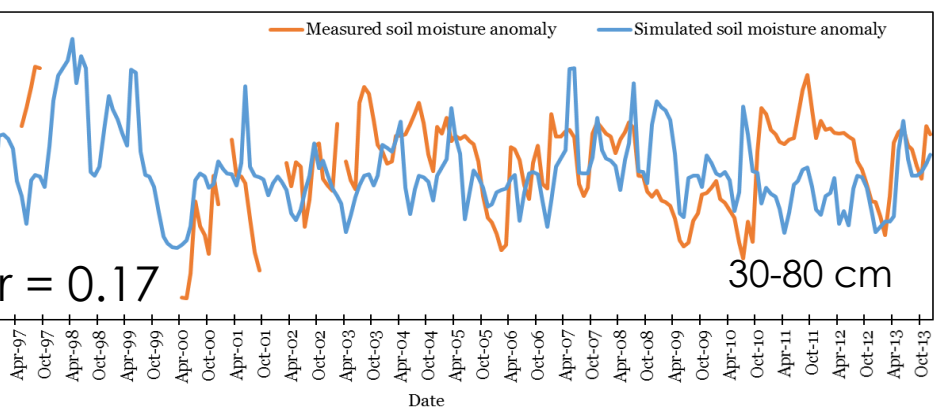
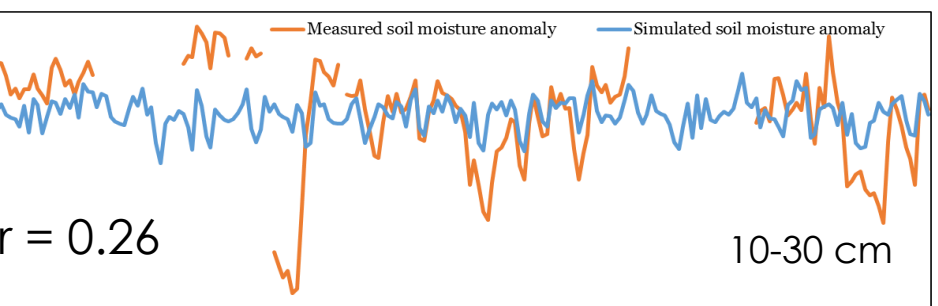
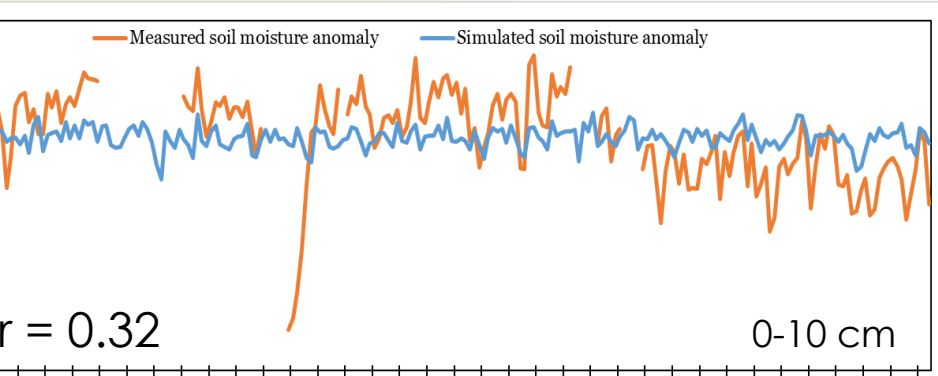
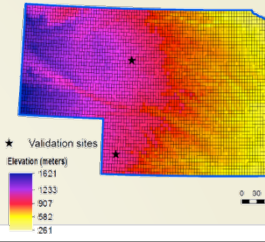

Before parameterization

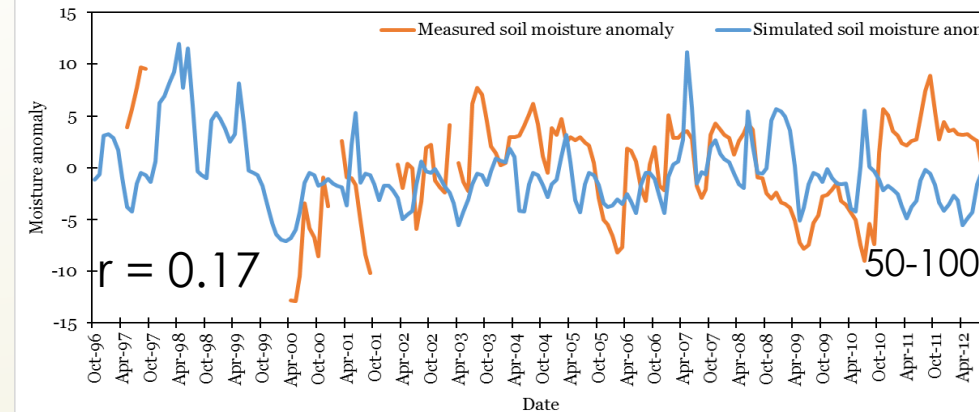
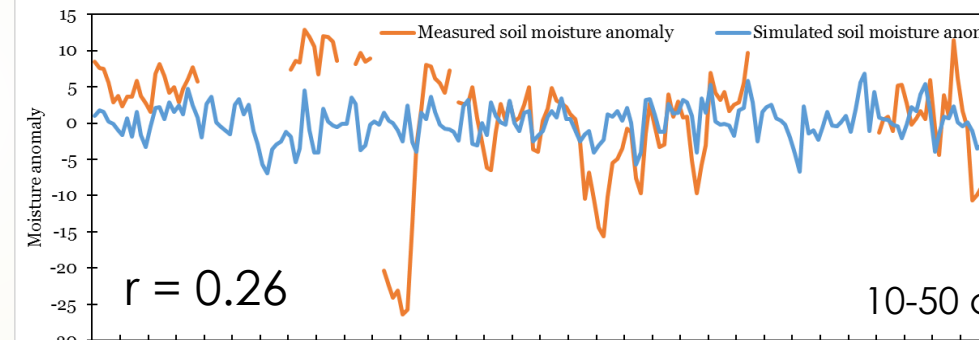
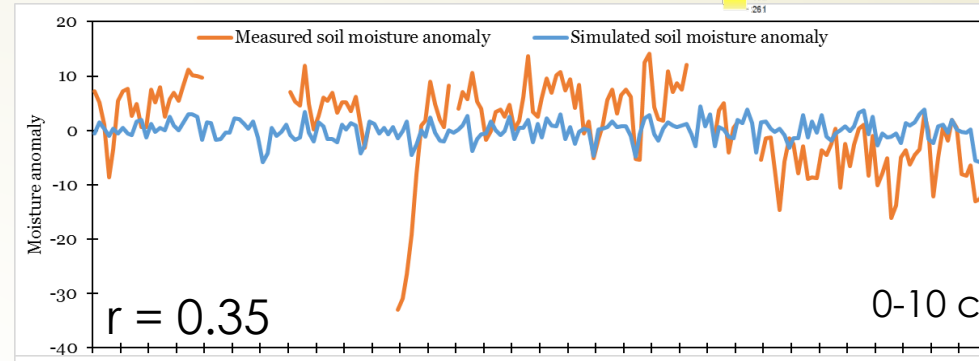

Moisture units are %

After parameterization

Validation results – Soil moisture

Johnson Farm

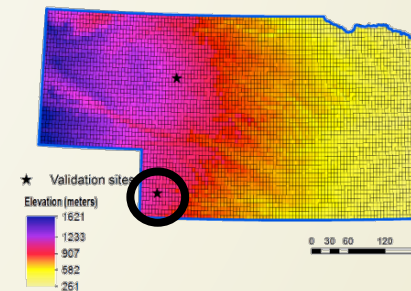
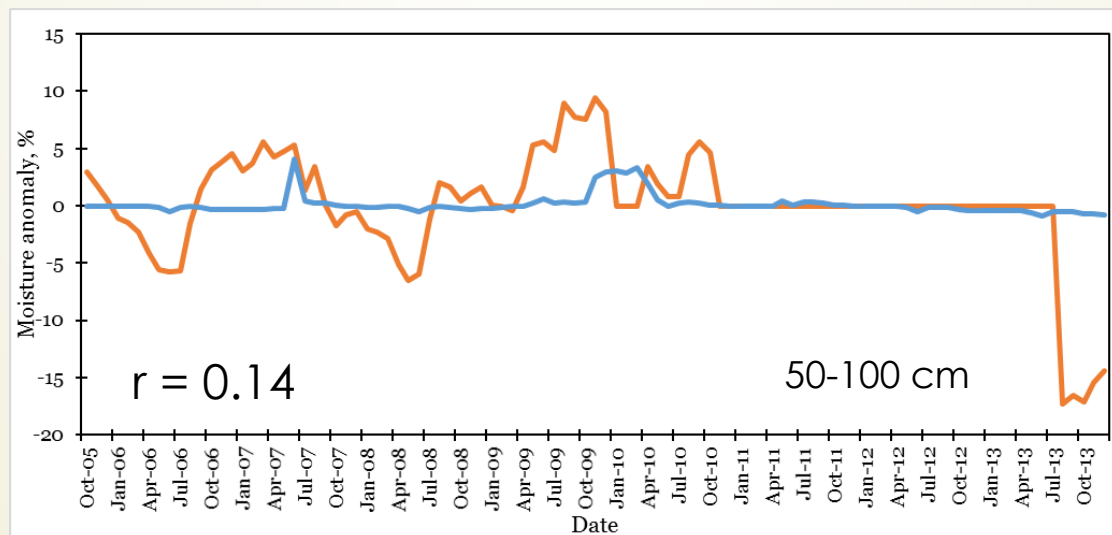
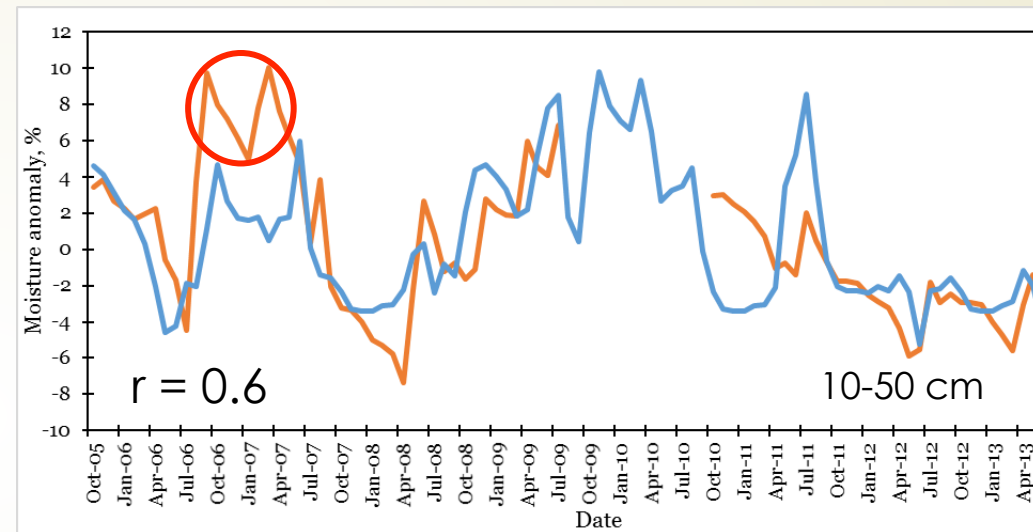
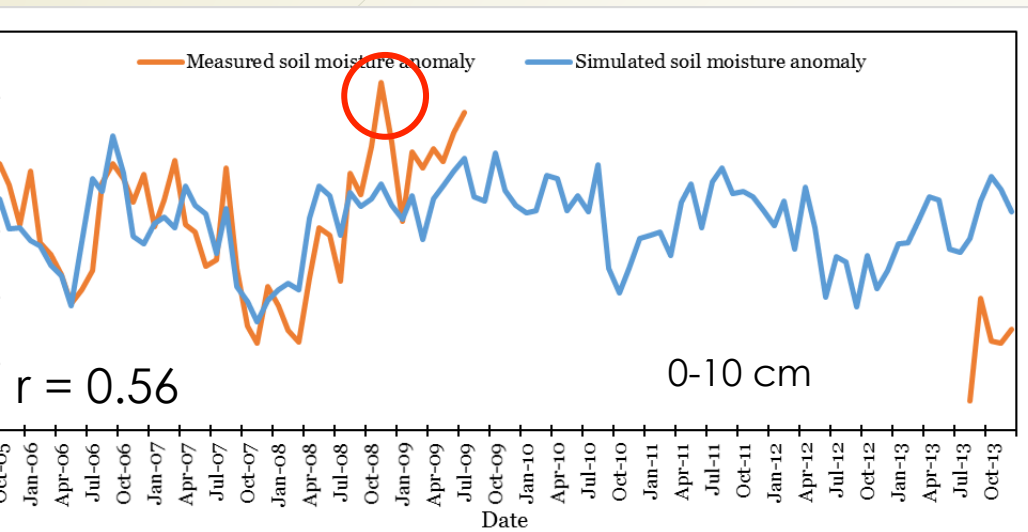

Validation results – ET

Sandhills

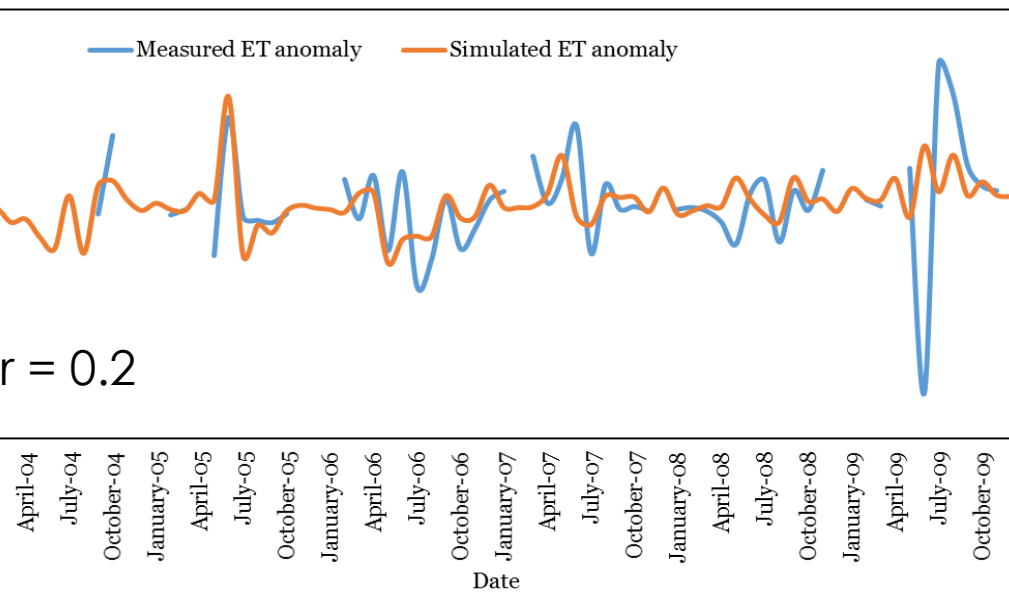

Mead

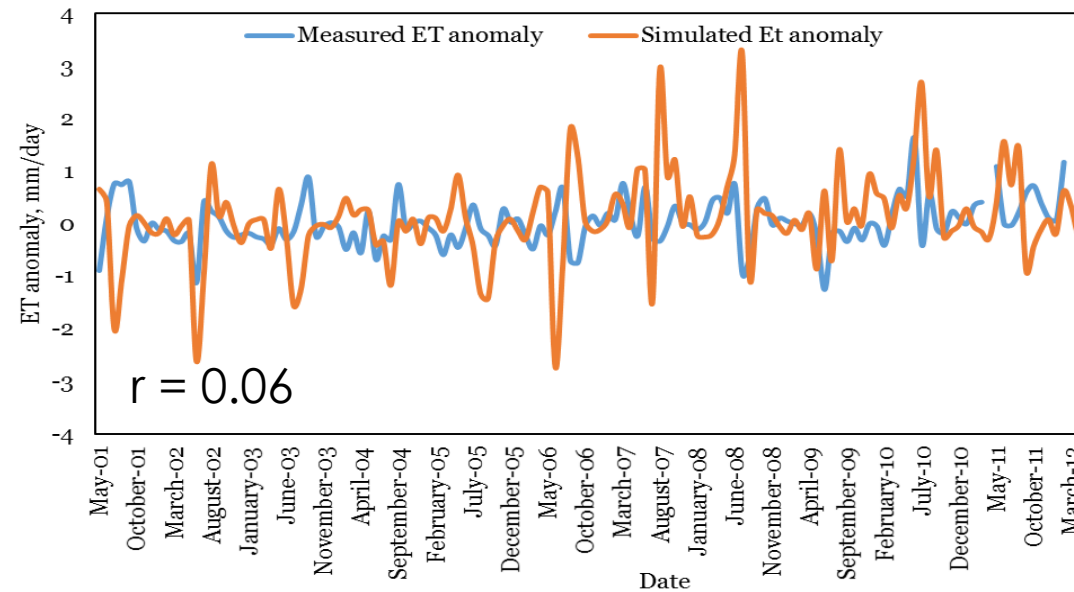

Validation results – Surface Temperature

Sandhills

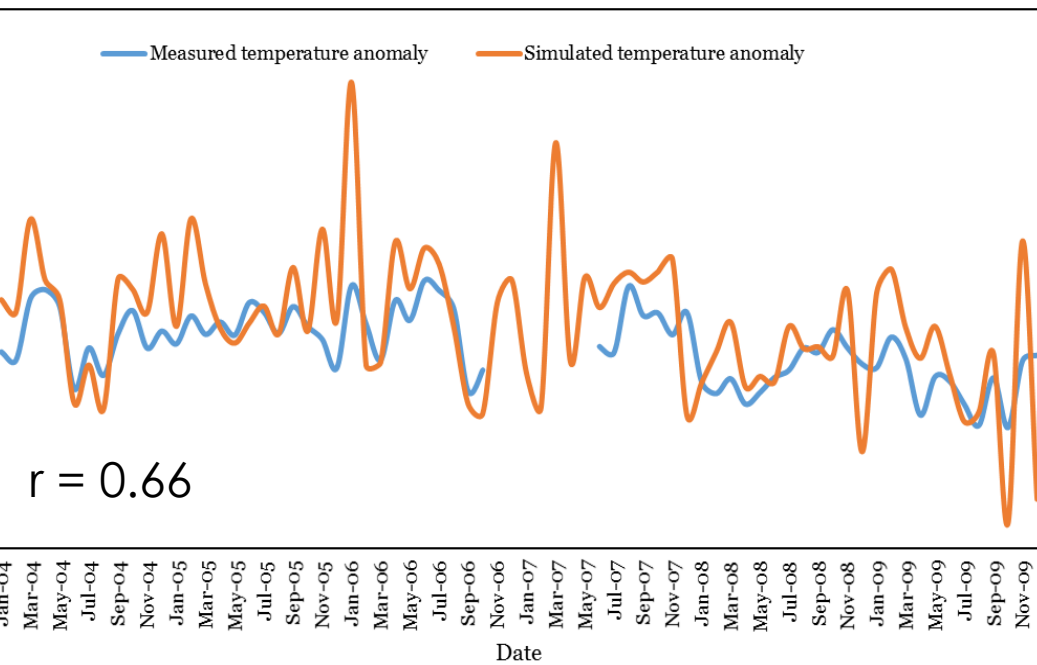

Mead

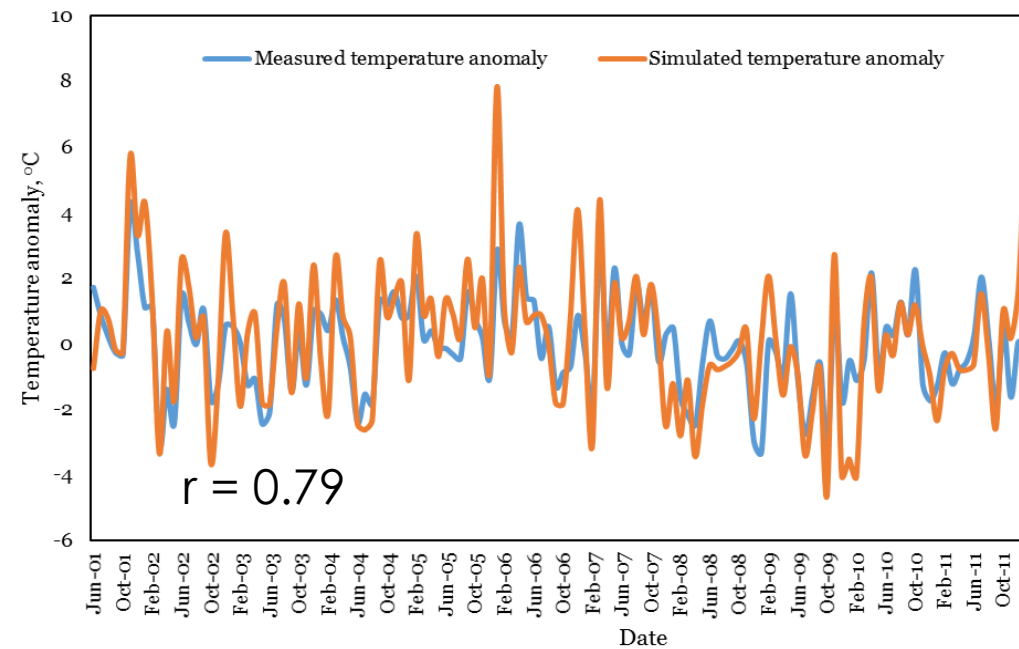



Conclusion

- ▶ Simulated and measured soil moisture anomalies had good correlation for first two layers at all sites.
- ▶ Simulated and measured ET anomalies showed very poor correlation
- ▶ Best correlation was found for surface temperature
- ▶ Spatial distribution of soil moisture for three layers was consistent, showing an increase from southeast NE to northwest.
- ▶ Spatial distribution of ET showed an increasing trend from southeast NE to northwest with highest ET for the month of June and July.



Issues and challenges

- ▶ Validation against field data – two issues
 - ▶ Firstly, field measurements are made at the point scale while models provide an estimate for a specified area, producing a disparity in scales
 - ▶ Secondly, soil moisture is highly variable in space, meaning that individual point measurements rarely if ever represent the spatial average of even small areas
- ▶ Validation of the model should be done for many point measurements
- ▶ Parameterization of the model for the study area



Thank you!
Questions and Suggestions



**NRES- 879 HYDROCLIMATOLOGY
SIMULATION OF SOIL MOISTURE AND EVAPOTRANSPIRATION FOR
THE STATE OF NEBRASKA USING VARIABLE INFILTRATION
CAPACITY MODEL**

Vasudha Sharma

ABSTRACT

Soil moisture is a key variable in controlling the exchange of water and heat energy between the land surface and the atmosphere through evaporation and plant transpiration. As a result, soil moisture plays an important role in the development of weather patterns and the production of precipitation. Despite the importance of soil moisture information, continuous measurements of surface soil moisture with global coverage is nonexistent. This study focuses on simulating the soil moisture, Evapotranspiration (ET) and surface temperature using Variable Infiltration Capacity (VIC) land surface macroscale hydrology model for the state of Nebraska (NE), USA for a period of 1 January 1960 to 31 December 2013. The model is applied to 5544 grids in NE with a resolution 0.0625 X 0.0625 degrees. The total area of the domain is 200520 Km². In-situ soil moisture, ET and surface temperature measurements from four sites in the state are used for model validation. The results indicate that the simulated soil moisture showed an increasing trend from northwest to southeast in all soil moisture layers. ET also showed an increasing trend from west to east of the state. VIC performs well for the first soil moisture layer, however correlation with in-situ soil moisture decreased with depth. Simulated and measured ET anomalies showed very poor correlation. Best correlation was observed for surface temperature.

INTRODUCTION

Soil moisture is a key variable in controlling the exchange of water and heat energy between the land surface and the atmosphere through evaporation and plant transpiration. Change in soil properties such as albedo, soil thermal capacity due to change in soil moisture affects the near-surface climate. Soil moisture plays an important role in the formation and development of meso- and micro-scale weather system and the production of precipitation. In hydrological processes, soil moisture is also a significant indicator in hydrological process and ecosystem (Du et al., 2006; Boisserie et al., 2006). The spatial variation in soil moisture may also affect the formation of convective thunderstorm (Chang and Wetzel, 1991). Despite the fact that soil moisture plays an important role in weather, climate and ecosystems, long term and wide range of observational data are very sparse. For this reason, land surface hydrology models are very useful tool to provide comprehensive soil moisture dataset for weather and climate research

and prediction. Such modeling approach is able to generate a continuous spatial and temporal dataset that has consistence in physics.

In addition to soil moisture, evapotranspiration is one of the most important components of hydrologic cycle as well as in determining the water use efficiency in agriculture. Evapotranspiration is related to climatic factors, geologic locations, seasonal rainfall, available amount of soil moisture and types of crop. Estimation of actual ET may be useful in irrigation scheduling and proper designing of irrigation projects. With increasing pressure on water resources for competing users, large emphasis has been placed on water use efficiency in irrigated fields (Hatfield et al., 1996). Practical methods for the accurate estimation of water requirement for agriculture at larger scales are essential for better decision making in allocating and managing water resources. In this study, Variable Infiltration Capacity (VIC) land surface macroscale hydrology model was used to simulate soil moisture and ET in Nebraska, USA. The model is briefly described in materials and methods section. The objective of this study was to simulate the spatial distribution of soil moisture and ET from 1961 to 2013 for the state of Nebraska and to verify simulated soil moisture, ET and surface temperature by in-situ measured values (observational data) for four locations in the state.

MATERIALS AND METHODS

Study area

The study is conducted for the entire state of Nebraska. The total area of the state is approximately 200,356 Km² which makes it the 16th largest state in the U.S. The average elevation of the state is 793 m above mean sea level. The major river basins in the state are the Missouri, Niobrara, Platte and Republican River basins. Due to its interior continental location, Nebraska has wide climatic seasonal variation with warm summers and extremely cold winters. The state also experiences a wide range of seasonal variation in temperature and precipitation. There are 138 soil series and many soil types and phases, which further differentiate the soil series in the state. Of these 138 soil series, 17 soil series constitute about 49% of the land area (NRCS-USDA web soil survey, <http://websoil survey. nrcs.usda.gov/app/HomePage.htm>). This study uses daily temperature and precipitation data from Livneh datasets for 1960-2013. The soil moisture and other fluxes are simulated on daily time step and the water balance was calculated

at a resolution of 0.0625 X 0.0625 degrees in the VIC model. The study area is shown in figure 1.

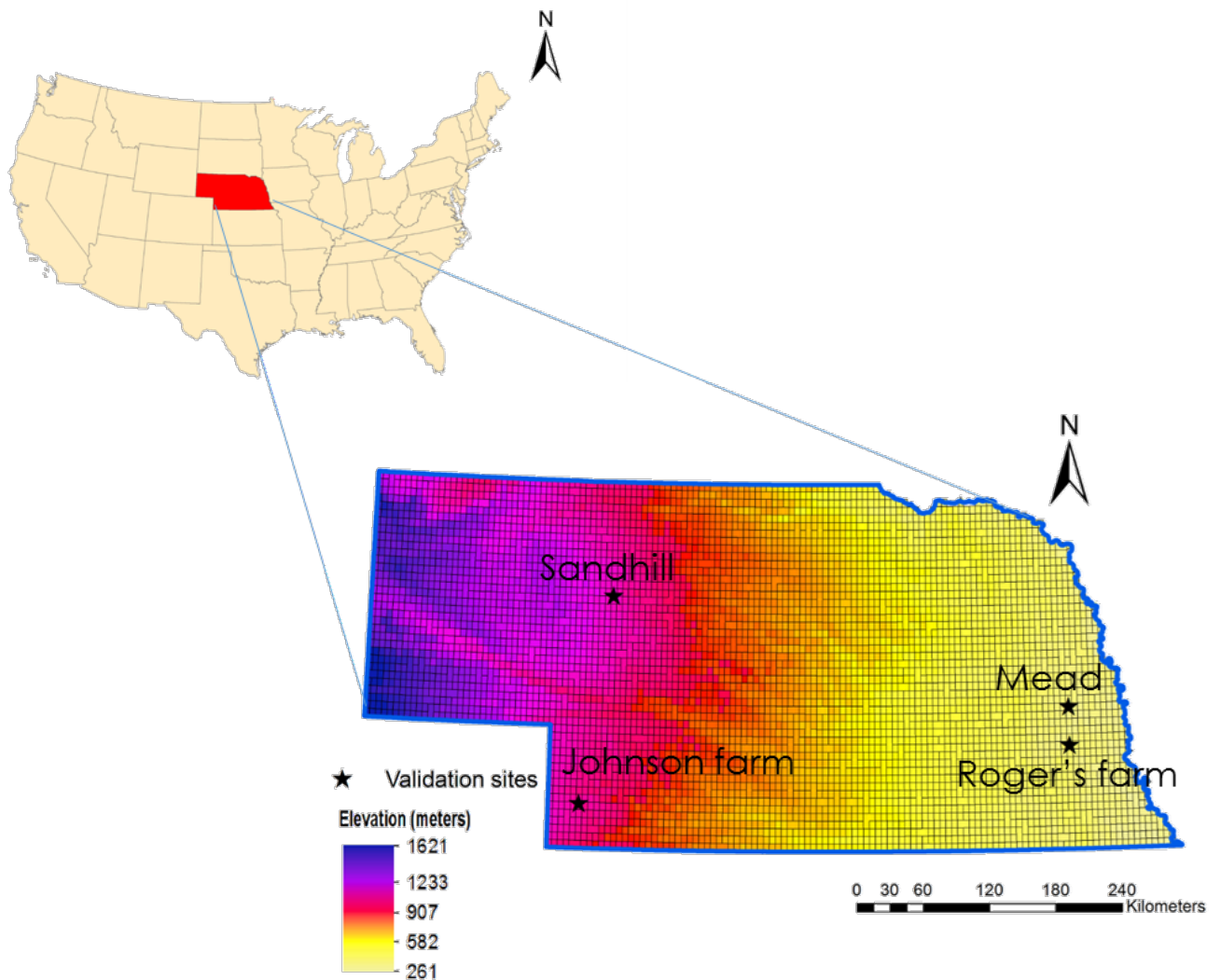

Figure 1. The Nebraska map shown above is the VIC model grid with 5544 grid points, at a resolution of 6 km X 6 km. The stars show the four sites where in situ soil moisture measurements are available.

Model description

The variable infiltration capacity (VIC) model is a typical land surface hydrological model (Liang et al., 1996). It has been successfully applied to simulate soil moisture over large areas and at different scales (Wu et al., 2007; Wu et al., 2015). In this model each grid cell's land cover is subdivided into arbitrary number of "tiles", each corresponding to the fraction of the cell

covered by that particular land cover (e.g. coniferous evergreen forest, grassland, etc.). Model lumps all patches of same cover type into 1 tile. The fluxes and storages from the tiles are averaged together (weighted by area fraction) to give grid-cell average for writing to output files. For each tile, Jarvis-style veg stomatal response is used for computing transpiration. It considers canopy energy balance separately from ground surface and account for partial veg cover fraction, allowing for bare soil evaporation from between the individual plants. VIC model has the capability to read daily time series of LAI, albedo, and partial veg cover fraction from forcing files instead of using the monthly climatology specified in the veg library or veg parameter files. In VIC model there are arbitrary number of soil layers, but typically there are 3 (Figure 2). The infiltration into the top-most layers is controlled by variable infiltration capacity (VIC) parameterization and only top-most layers can lose moisture to evapotranspiration. The flow from upper layers to lower layers is gravity-driven. VIC model uses five types of input files: Global parameters file which points VIC to the locations of the other input/output files and sets parameters that govern the simulation, meteorological forcing files containing daily or sub-daily timeseries of meteorological variables as inputs which can be gridded or point station data or reanalysis fields, soil parameters File containing information regarding lat/lon, soil texture and other characteristics, vegetation Library file containing available land cover types and vegetation parameter file containing information of landcover types, fractional areas, rooting depths, and seasonal LAIs of the various landcover tiles within each grid cell.

For this study, the very initial step in modelling land surface was to create a list of grid cells contained within the domain. For this purpose, Arc geographical information system (GIS) was used. The shapefile for the state of Nebraska was obtained from geospatial dataset gateway. Then a digital elevation mask (DEM) file for whole United States (USA) was downloaded from USGS website. The next step in delineation process was to extract the DEM of domain. Extract by mask tool in GIS was used to extract NE DEM from USA. After this the resampling tool in

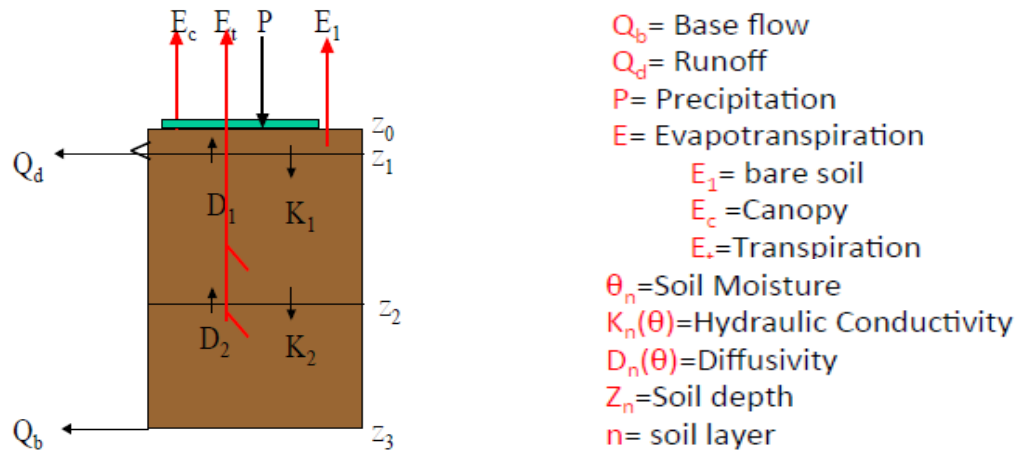

Figure 2. Overview of VIC modeling

GIS was used to convert the domain to our desired resolution of 0.0625 and tolerance of 0.0001. Once the domain was prepared we converted this raster to Ascii (Text file) so that we can use in the model. After running the model with all the inputs mentioned above files for ET, soil moisture and surface temperature were created. After obtaining these files for each grid cell, the text file was converted into the netCDF format. The script used in this process comprised of four steps: reading the text file, defining the grid, allocate values in each grid and then write results in netCDF format. By the end of this step we obtained a separate file for evapotranspiration, soil moisture for three layers and surface temperature. After this step we converted daily values of each variable to monthly time step. The next important step in the post processing is the spatial aggregation.

To validate the VIC model, the soil moisture data from four locations and ET and surface temperature data from two locations (Sandhills and Mead) in Nebraska as shown in figure 1. was used. The location of the sites and source of data is shown in table 1. After spatially aggregating for the domain i.e., NE, we used a script in Linux to identify the grid cells of the validation sites. Daily and monthly data for all variables for each validation site was obtained in the text file. The model was ran two times with different depth of the soil layers used in the model. In the first run, the soil layers were 10 cm, 20 cm and 50 cm. In the second run, the model ran separately for each depth to match the depths with the observational data in order to compare them.

Table 1. Location and source of validation data

Location	Latitude	Longitude	Source of data	Variables obtained
Sandhills	42.0693	-101.4072	Ameriflux	Hourly soil moisture (10 cm and 25 cm), ET and surface temperature (2004-2009)
Mead	41.1649	-96.4701	Ameriflux	Hourly soil moisture (10 cm and 25 cm), ET and surface temperature (2001-2013)
Roger's farm	40.37	-101.72	SCAN	Daily soil moisture (10cm, 50 cm and 100 cm) (1996-2013)
Johnson's farm	40.85	-96.47	SCAN	Daily soil moisture (10cm, 50 cm and 100 cm) (2005-2013)
SACN: Soil climate analysis network-NRCS (http://www.wcc.nrcs.usda.gov/scan/), Ameriflux data: (http://ameriflux.ornl.gov/)				

RESULTS AND DISCUSSION

Rationality analysis of simulated soil moisture, ET and surface temperature

The soil moisture obtained from the station data (point data) is usually quite different from the average simulated values of the grids (256 km²) due to the inhomogeneity of soil layers. Also, VIC model gives us soil moisture in millimeters of water in a particular depth which we convert into volumetric water content by dividing it by layer thickness whereas data we obtained from stations is the volumetric water content at a point. Because of this reason, the comparison between the two is questionable. However, many studies have proposed that rationality of simulated results can be verified by contrasting the simulated anomalies with the observed (Wu et al., 2015). In this study, we contrasted the monthly average anomalies of ET, soil moisture and surface temperature from simulated results with observed anomalies. The anomalies are computed as follows:

$$Y_i = x_i - \bar{x}_i$$

Where, x_i represent the current value of the variable and \bar{x}_i represent its climatology. Correlation coefficients (r) were calculated for all the comparisons. Figure 3, 4, 5 and 6 represents the comparisons of soil moisture anomalies for Sandhills, Mead, Roger's farm and Johnson's farm, respectively. Units of soil moisture anomalies are in %. Statistically, correlation coefficients of first layer 0-10 cm was 0.33, 0.41, 0.32 and 0.56 for Sandhills, Mead, Roger's farm and Johnson's farm, respectively. Changing the depth of the soil layers in the model did not make

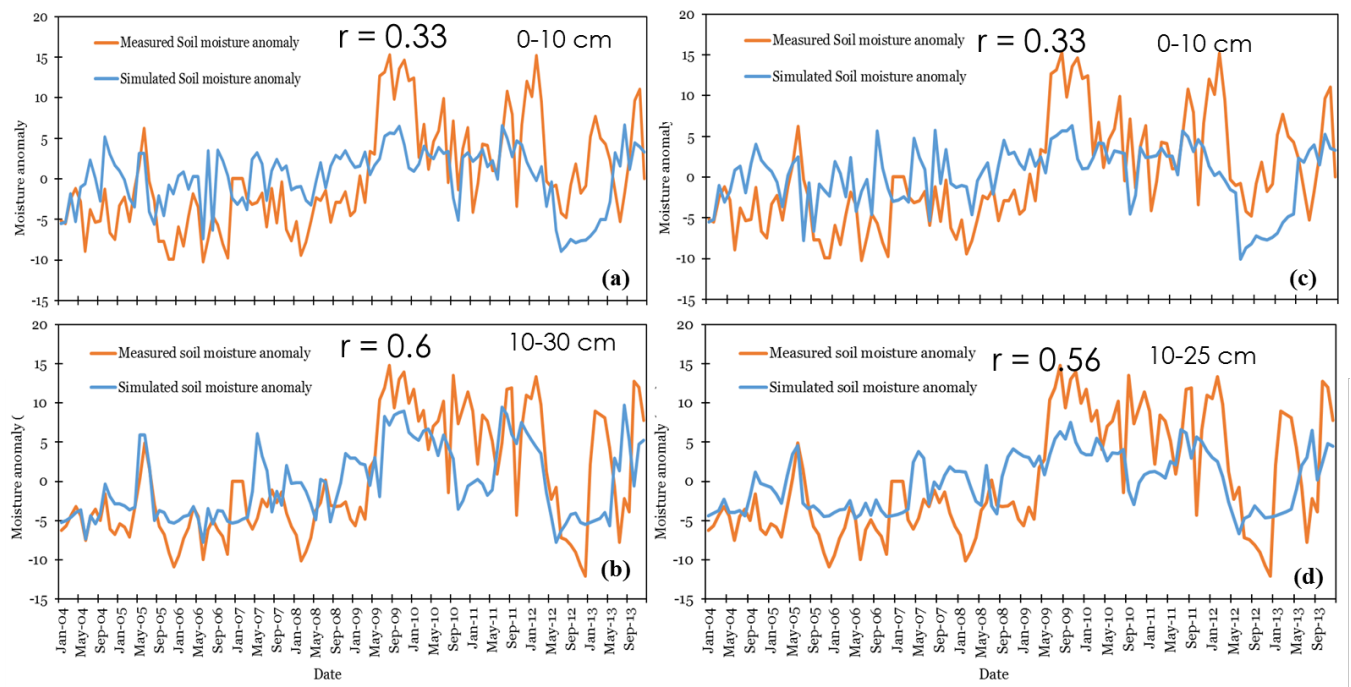

Figure 3. Comparison of simulated (blue line) and measured (orange line) soil moisture (%) anomalies for (a) 0-10 cm before parametrization (b) 10-30 cm before parameterization, (c) 0-10 cm after parametrization and (d) 10-25 cm after parametrization at Sandhills.

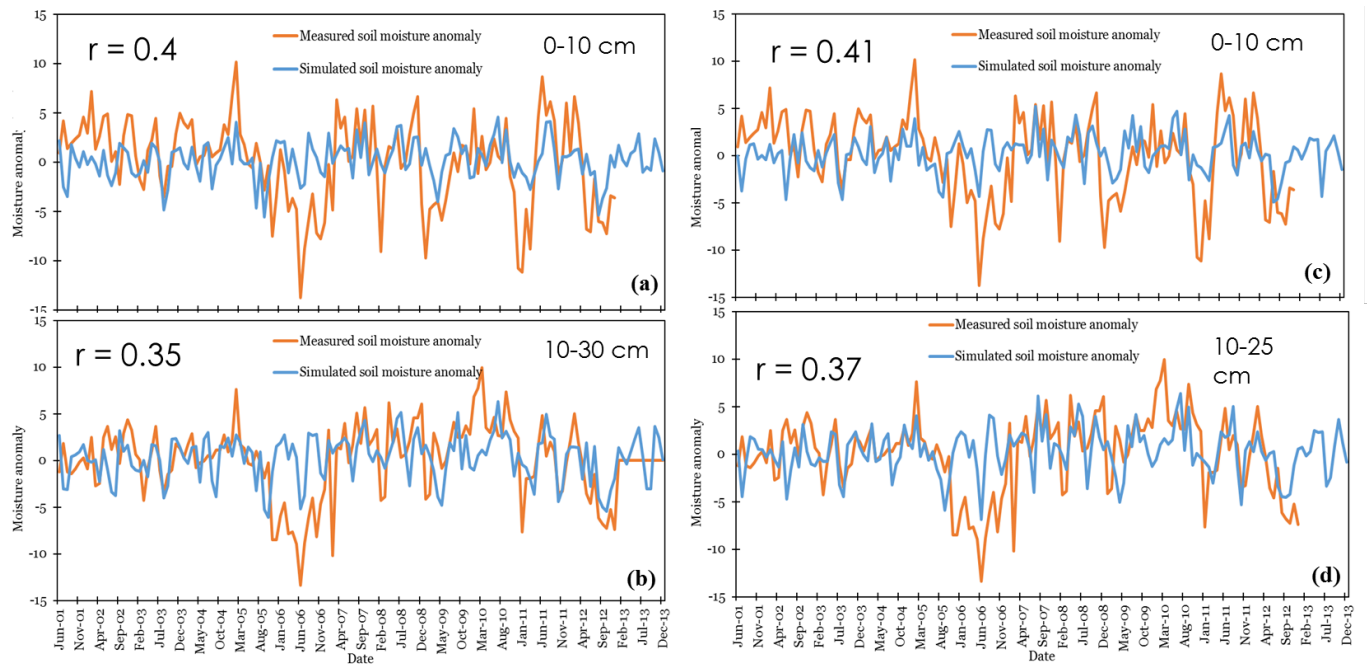

Figure 4. Comparison of simulated (blue line) and measured (orange line) soil moisture (%) anomalies for (a) 0-10 cm before parametrization (b) 10-30 cm before parameterization, (c) 0-10 cm after parametrization and (d) 10-25 cm after parametrization at Mead.

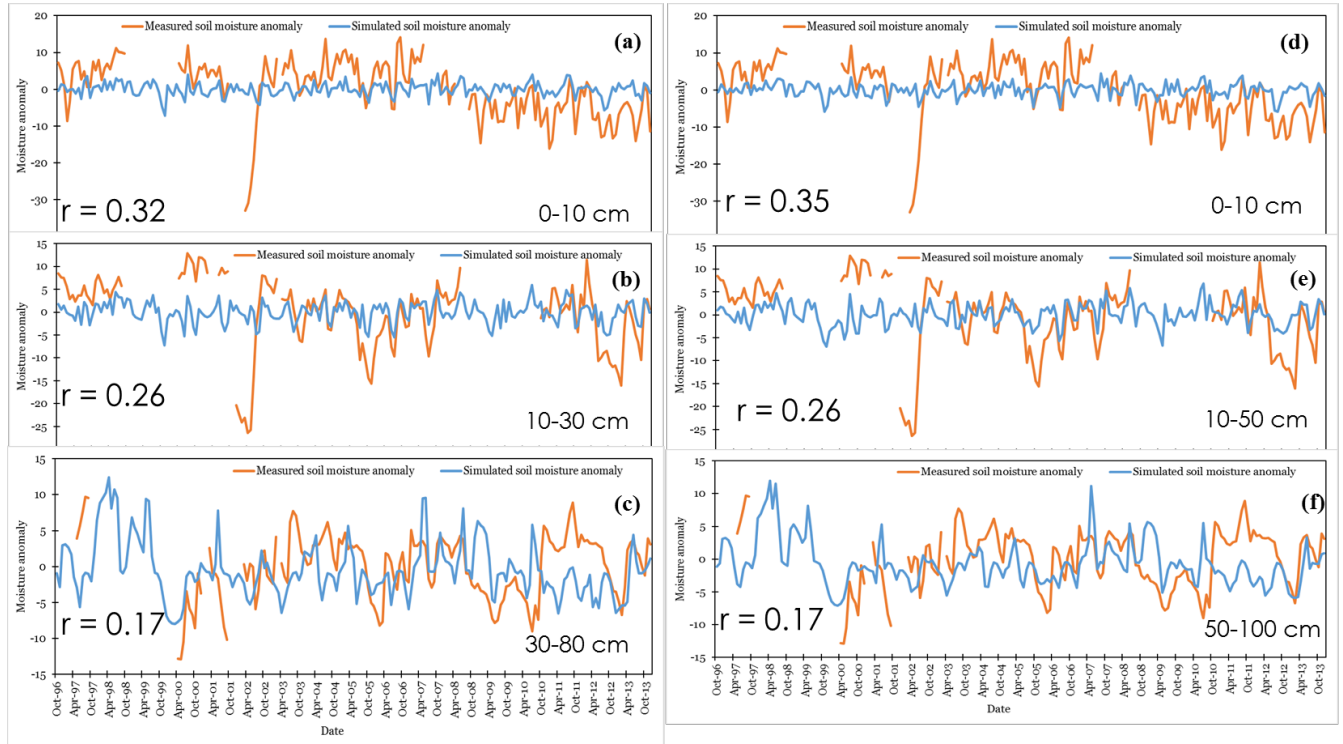

Figure 5. Comparison of simulated (blue line) and measured (orange line) soil moisture (%) anomalies for (a) 0-10 cm before parametrization (b) 10-30 cm before parameterization, (c) 30-80 cm before parametrization, (d) 0-10 cm after parametrization, (e) 10-50 cm after parameterization and (f) 50-100 cm after parametrization at Roger’s farm.

any difference in the correlation coefficient values. Value of correlation coefficient increased for the second layer (0-25 cm) at Sandhills and Johnson’s site ($r=0.60$), however, decreased at Mead and Roger’s site. Correlation was very poor for the third layer. The reason behind this poor correlation was that the third layer was 50 cm thick and we were comparing volumetric water content measured at a point (observational data) with what we calculated from 50 cm thick layer. This added error in the measurements. From all the comparison we observed that VIC simulation is always bad when there is an extreme event. It is incapable of simulating all variables including surface temperature when there is extreme. From this study, we observed that validation against field data has two issues. Firstly, field measurements are made at the point scale while models provide an estimate for a specified area, producing a disparity in scales. Secondly, soil moisture is highly variable in space, meaning that individual point measurements rarely if ever represent the spatial average of even small areas.

Similar to soil moisture, ET and surface temperature anomalies were plotted (figure 7 and 8). ET showed poorest correlation, however, surface temperature showed strongest correlation among all three variables. The reason behind the poor correlation of ET might be that the VIC model gives us an average value of a grid and assumes that grid cells do not interact with each other. Since, one grid cell is 6 km x 6km and there might be many types of land covers in this area whose average is used by the VIC. So the ET value given by VIC is the ET from all those land covers. However, observational ET is from a point and it is surface specific.

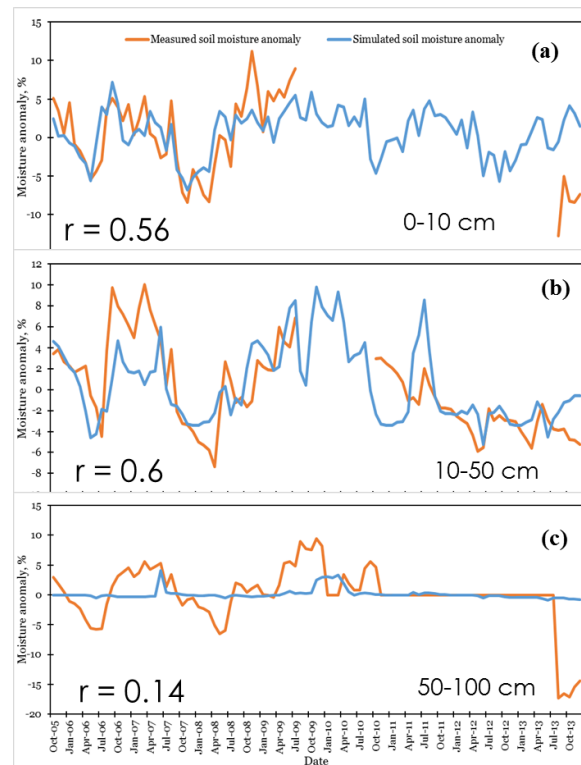

Figure 6. Comparison of simulated (blue line) and measured (orange line) soil moisture (%) anomalies for (a) 0-10 cm after parametrization, (b) 10-50 cm after parameterization and (c) 50-100 cm after parameterization at Johnson's farm.

Reason behind the high correlation in surface temperature is that the surface temperature is a function of ambient temperature which is one of the inputs of VIC model. Thus, correlation is better because we are comparing the observational data with something derived from the observational data.

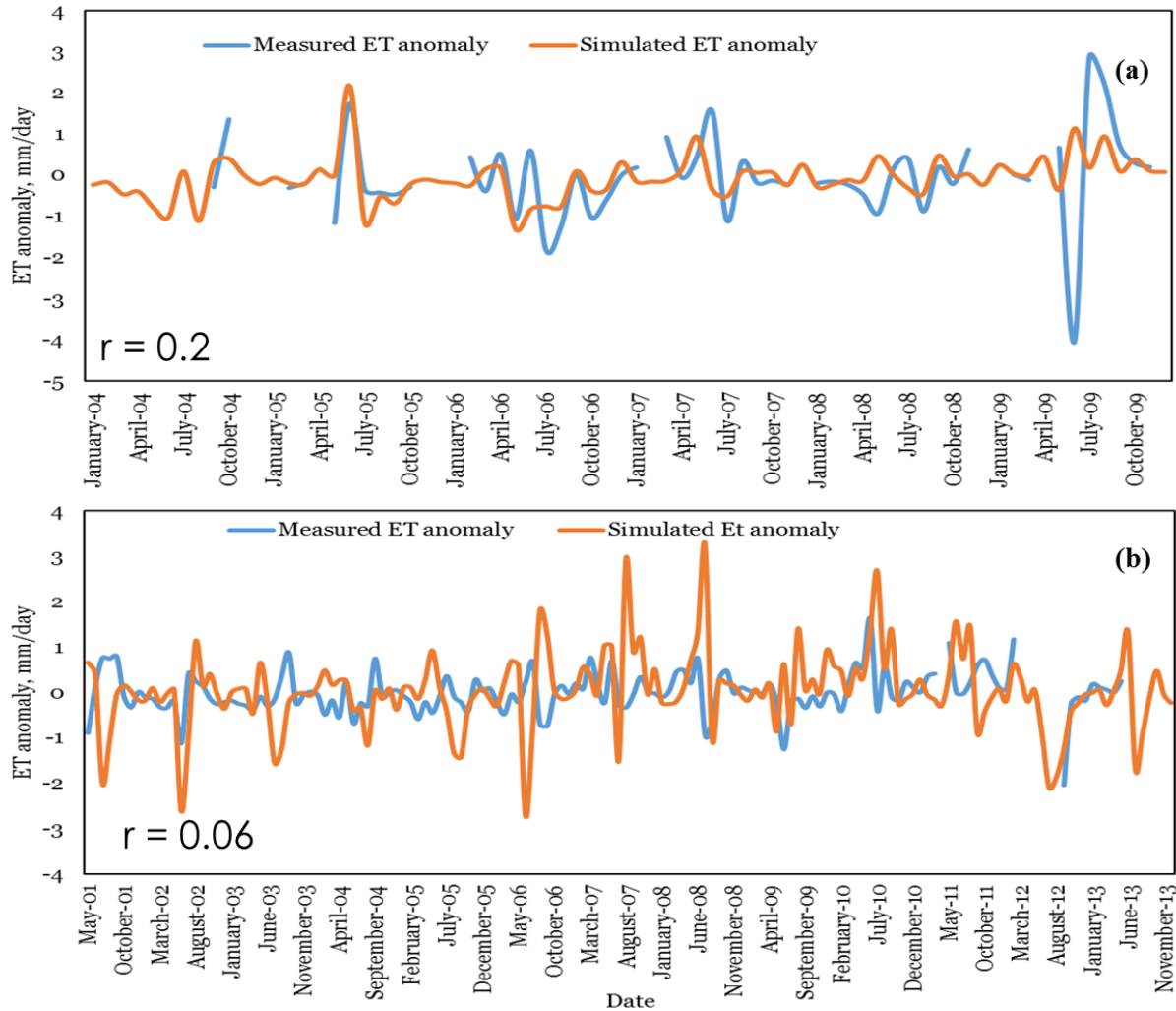

Figure 7. Comparison of simulated (blue line) and measured (orange line) ET anomalies for (a) Sandhills, and (b) Mead site.

Simulated soil moisture and ET of Nebraska for the growing season

Figure 9 and 10 showed the spatial distribution of simulated soil moisture and ET for the state of Nebraska. From the figure we can see that simulated moisture for each layer shows gradually increasing trend from northwest to southeast NE. The highest values of soil moisture occur in the south central parts of the state which is the most irrigated crop land in the state. ET also showed an increasing trend from west to east of the state. Similar to soil moisture maximum ET was found in the south central part of the state and in the months of June and July which is the peak growing season in the state.

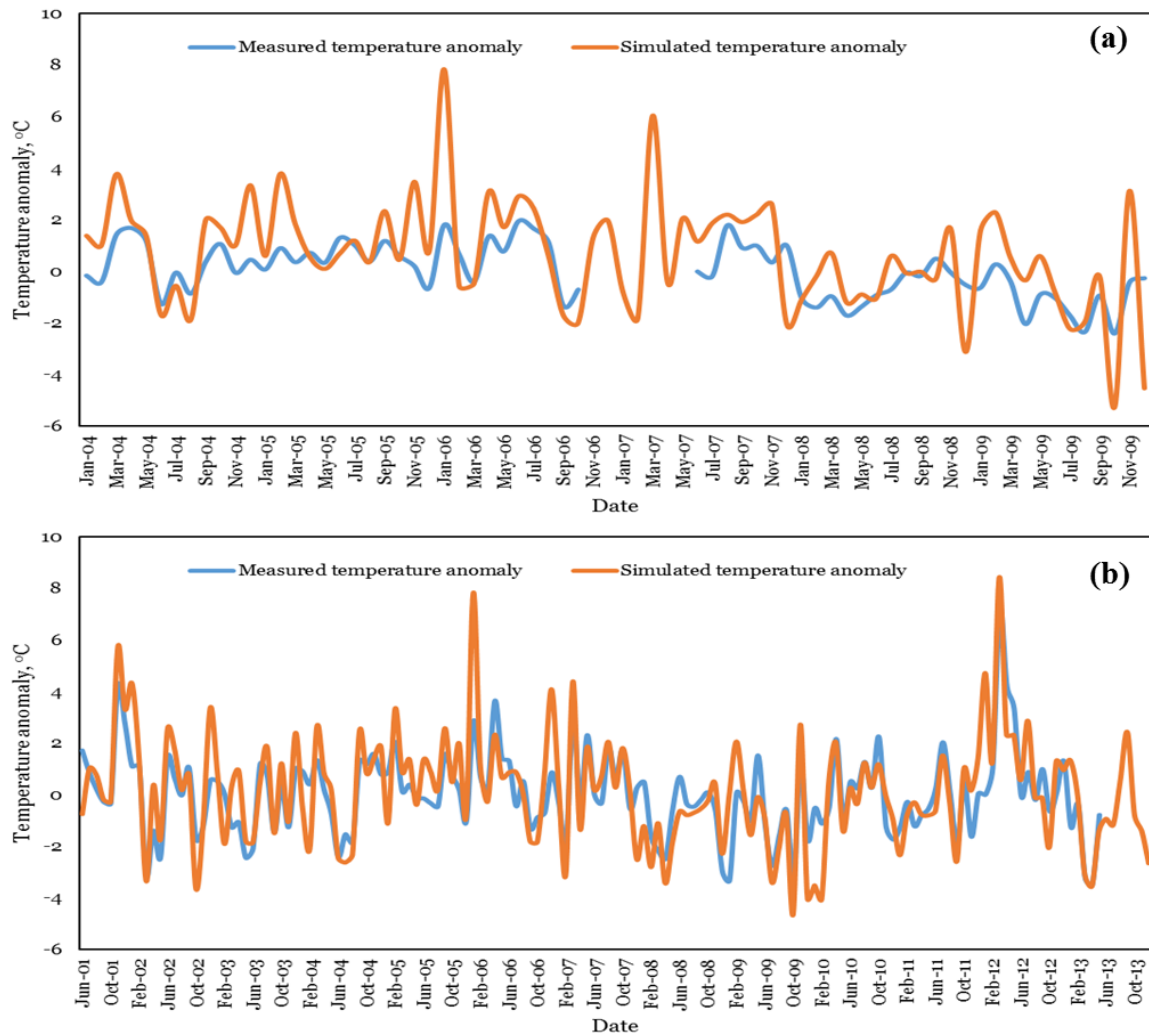

Figure 8. Comparison of simulated (blue line) and measured (orange line) surface temperature anomalies for (a) Sandhills, and (b) Mead site.

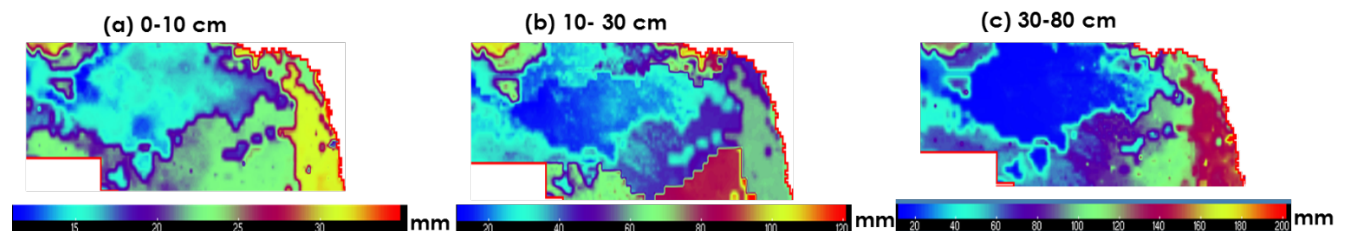

Figure 9. Spatial distribution of simulated soil moisture in NE

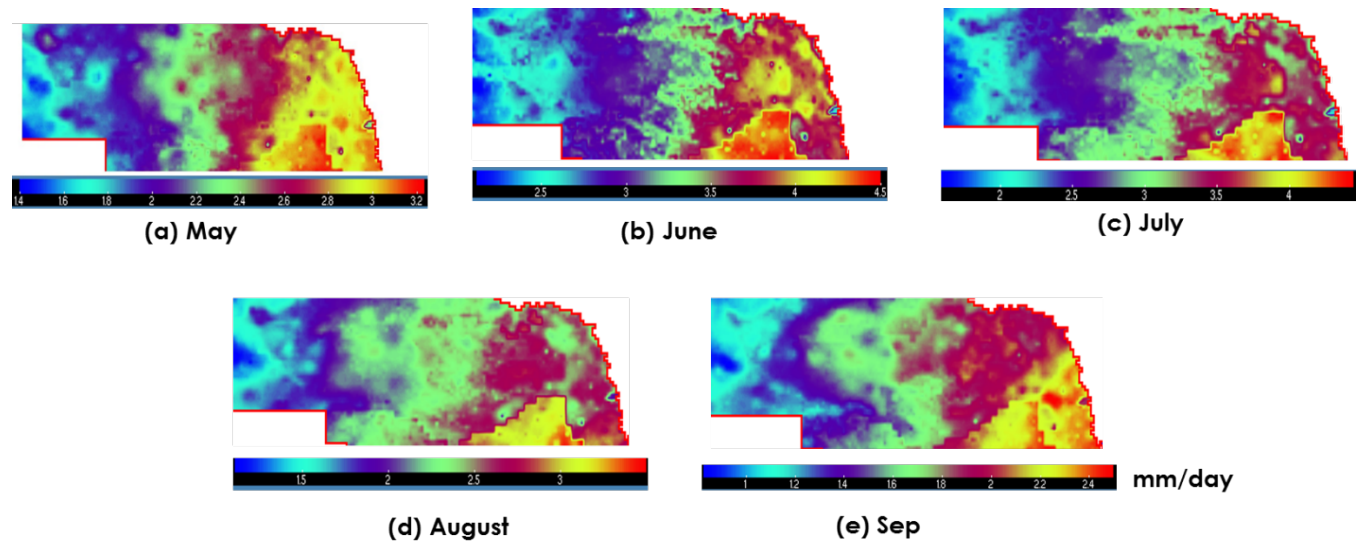

Figure 10. Spatial Distribution of ET in NE over the growing season.

CONCLUSIONS

In this study, the VIC model was driven by daily precipitation, maximum and minimum air temperature to generate daily soil moisture and ET for the state of NE from 1960-2013 and simulated data was verified by measured data from four stations in the state. The results obtained are:

1. Simulated and measured soil moisture anomalies had good correlation for first two layers at all sites.
2. Simulated and measured ET anomalies showed poor correlation.
3. Best correlation was found for surface temperature anomalies.
4. Spatial distribution of soil moisture for three layers was consistent, showing a decreasing trend from southeast NE to northwest.
5. Spatial distribution of ET showed an increasing trend from southeast NE to northwest with highest ET for the month of June and July.

REFERENCE

Boisserie, M., D. Shin, T. Larow and S. Cocke. 2006. Evaluation of soil moisture in the Florida State University climate model–National Center for Atmospheric Research community

- land model (FSU-CLM) using two reanalyses (R2 and ERA40) and in situ observations. *Journal of Geophysical Research: Atmospheres* 111(D8).
- Chang, J. and P. J. Wetzel. 1991. Effects of spatial variations of soil moisture and vegetation on the evolution of a prestorm environment: A numerical case study. *Monthly Weather Review* 119(6): 1368-1390.
- Du, C., W. Wu, X. Liu and W. Gao. 2006. Simulation of soil moisture and its variability in East Asia. In *SPIE Optics Photonics*, 62982F-62982F-6. International Society for Optics and Photonics.
- Liang, X., Wood, E.F. and Lettenmaier, D.P. (1996) Surface soil moisture parameterization of the VIC-2L model: Evaluation and modification. *Global and Planetary Change* 13(1), 195–206.
- Wu, Z., G. Lu, J. Zhang and Y. YANG. 2007. Simulation of daily soil moisture using VIC model. *Scientia Geographica Sinica* 27(3): 359.
- Wu, Z., Y. Mao, G. Lu and J. Zhang. 2015. Simulation of soil moisture for typical plain region using the Variable Infiltration Capacity model. *Proceedings of the International Association of Hydrological Sciences* 368215-220.
- Wu, Z., G. Lu, L. Wen, C. A. Lin, J. Zhang and Y. Yang. 2007. Thirty-five year (1971–2005) simulation of daily soil moisture using the variable infiltration capacity model over China. *Atmosphere-Ocean* 45(1): 37-45.

Appendix 9

NRES/METR/BSEN 479/879

Spring 2016

Questionnaire

Due: Thursday, May 12th

Undergraduate/Graduate Program Ph.D. In Biological Engineering

Year in the program 1st

This Questionnaire aims to provide feedback to the Hydroclimatology-course activities (General, Lectures, Discussions, Labs, and Assignments and Final Project).

General

- 1) Was the course helpful for your research needs?
 - a) **yes**
 - b) yes, it added a new perspective to my research
 - c) no, but I learned something new
 - d) no
- 2) What part of the course was the best for you?
 - a) Lectures
 - b) Discussions
 - c) Labs
 - d) Assignments
 - e) **Final project**
 - f) None
- 3) What part of the course has to be improved? (you can select from 1 to all options)
 - a) Lectures
 - b) Discussions
 - c) Labs
 - d) **Assignments**
 - e) Final project
- 4) Was the information provided to you: _____ . Why? (Provide a brief answer in 1 to all options).
 - a) Relevant, because it all was related to the hydroclimatology discipline
 - b) Updated, because we studied recent literature.
 - c) Inaccurate, because -----
 - d) Unexplained, because -----
 - e) Motivational, because the instructor presented good challenges

f) Challenging, because novel techniques were introduced

5) How did you find this course?

a) Advisor

b) Department

c) Committee member

d) My program requires it

e) Instructor

f) Email list

g) Class mate (friend/member of the same research group)

h) Previous student

6) Would you consider the course _____ strength/balanced/poor? (two selections per incise; 1 to 4 incises to select)

a) Analytically strength/balanced/poor (i.e. precipitation generation was properly explained)

b) Computationally strength/balanced/poor (i.e. precipitation was spatially estimated using specific coded)

c) Mathematically strength/balanced/poor (i.e. I developed or learn how to develop expressions to estimate precipitation)

d) Statistically strength/balanced/poor (i.e. I use statistics to evaluate the spatial distribution and/or tempo ral variability of precipitation)

e) None of the above

7) What course(s) would be good to have as pre-requisites?

a) Hydrology/Water Resources

b) Meteorology

c) Programing

d) GIS

e) Statistics

f) Numerical Methods

g) None of them

8) What is your background? (Undergraduate major and minor; and graduate program)

UG: Agricultural Engineering

MS: Agricultural and Biological Systems Engineering

Ph.D.: Biological Engineering

9) What is your current undergraduate/graduate program

Ph.D.: Biological Engineering

10)Based on your experience in this course (Hydroclimatology). What course(s) will you take in the fall (if is currently offered at UNL)?

Irrigation Systems design (advanced)

11) Based on your experience in this course (Hydroclimatology). What course(s) would you like to take (that is/are not offered by UNL)?

- a) **Geostatistics**
- b) Programing for scientists and Engineers
- c) Extreme Hydrometeorological and Climate Events: Diagnosis, Forecast Prediction, and Risks
- d) Risk Assessment
- e) Data science and engineering
- f) **Integrated Systems Analyses**

11) Based this space to provide additional feedback that was not addressed above

Lectures

12) Was/were _____?

- a) Course sequence correct yes/no
- b) Course content appropriate yes/no
- c) Topics ' depth right yes/no
- d) Slides clear yes/no

13) Was the teacher knowledgeable?

- a) Theory yes/no
- b) Practical experience yes/no
- c) Teaching yes/no
- d) Modeling yes/no
- e) Programing yes/no

14) Were resources available to the class enough?

- a) Course materials yes/no
- b) Teaching assistance yes/no
- c) Computational Resources yes/no
- d) Office hours yes/no

15) Would additional topics in the broad subjects below recommended?

- a) Statistics yes/no
- b) Hydrology yes/no
- c) Climatology yes/no
- d) Data Science yes/no
- e) Other _____.

Discussions

16) Was/were discussions_____?

- a) Aligned with the lectures yes/no
- b) Aligned with the Labs yes/no
- c) Relevant to the course yes/no
- d) Irrelevant yes/no

17) Were the papers covered?

- a) Appropriate yes/no
- b) Key yes/no
- c) Updated yes/no
- d) Useful yes/no

18) Were discussions' formats appropriate?

- a) Presentation of a paper yes/no
- b) Roundtable yes/no
- c) Debate yes/no
- d) Useful yes/no

Labs

19) Was/were Labs_____?

- a) Aligned with the lectures yes/no
- b) Aligned with the Labs yes/no
- c) Relevant to the course yes/no
- d) Irrelevant yes/no

20) Were the subjects covered?

- a) Appropriate yes/no
- b) Key yes/no
- c) Updated yes/no
- d) Useful yes/no

21) Were Labs' tools useful?

- a) For the course yes/no
- b) For your research yes/no
- c) For your thesis yes/no

22) Were following computational tools relevant?

- a) Operative System (LINUX) yes/no
- b) Infrastructure yes/no
- c) Pre-processing/post-processing Codes yes/no
- d) Plotting codes yes/no
- e) Modeling resources yes/no

23) Was TA (Carlos Carrillo-Cruz) helpful?

- a) Knowledgeable yes/no
- b) Available yes/no

c) Clear yes/no

24) Was TA (Daniel Rico) helpful?

a) Knowledgeable yes/no

b) Available yes/no

c) Clear yes/no

Assignments and Final Project

25) Was/were Assignments and Final Projects _____?

a) Aligned with the lectures yes/no

b) Aligned with the Labs yes/no

c) Relevant to the course yes/no

d) Irrelevant yes/no

26) Was your Final Project relevant for _____?

a) Research yes/no

b) General interests yes/no

c) Future work yes/no

d) Irrelevant yes/no

27) Is your Final Project useful to write a _____?

a) Research peer review paper yes/no

b) General public paper yes/no

c) Thesis yes/no

d) Report yes/no

28) Before you took this course were you thinking about writing a _____ on the subject of your Final Project?

a) Research peer review paper yes/no

b) General public paper yes/no

c) Thesis yes/no

d) Report yes/no

- d) My program requires it
 - e) Instructor**
 - f) Email list
 - g) Class mate (friend/member of the same research group)
 - h) Previous student
- 6) Would you consider the course _____ strength/balanced/poor? (two selections per incise; 1 to 4 incises to select)
- a) **Analytically strength**/balanced/poor (i.e. precipitation generation was properly explained)
 - b) **Computationally strength**/balanced/poor (i.e. precipitation was spatially estimated using specific coded)
 - c) **Mathematically strength/balanced**/poor (i.e. I developed or learn how to develop expressions to estimate precipitation)
 - d) **Statistically strength/balanced**/poor (i.e. I use statistics to evaluate the spatial distribution and/or temporal variability of precipitation)
 - e) None of the above
- 7) What course(s) would be good to have as pre-requisites?
- a) Hydrology/Water Resources**
 - b) Meteorology
 - c) Programing
 - d) GIS
 - e) Statistics
 - f) Numerical Methods
 - g) None of them
- 8) What is your background? (Undergraduate major and minor; and graduate program)
- Undergraduate: Agricultural Engineering**
Graduate: Agricultural and Biological Systems Engineering
- 9) What is your current undergraduate/graduate program
- Graduate program: Ph.D**
- 10)Based on your experience in this course (Hydroclimatology). What course(s) will you take in the fall (if is currently offered at UNL)?
- I am done with my course work**
- 11) Based on your experience in this course (Hydroclimatology). What course(s) would you like to take (that is/are not offered by UNL)?
- a) Geostatistics
 - b) Programing for scientists and Engineers
 - c) Extreme Hydrometeorologicale and Climate Events: Diagnosis, Forecast Prediction, and Risks**
 - d) Risk Assessment

- e) Data science and engineering
- f) Integrated Systems Analyses

11) Based this space to provide additional feedback that was not addressed above I think over all the course was very informative. Some improvements in the structure of lecture slides is needed. When you go back to lecture slides, due to lack of written information and only pictures, its' difficult to understand sometimes.

Lectures

- 12) Was/were _____?
- a) Course sequence correct yes/no
 - b) Course content appropriate yes/no
 - c) Topics ' depth right yes/no
 - d) Slides clear yes/no
- 13) Was the teacher knowledgeable?
- a) Theory yes/no
 - b) Practical experience yes/no
 - c) Teaching yes/no
 - d) Modeling yes/no
 - e) Programing yes/no
- 14) Were resources available to the class enough?
- a) Course materials yes/no
 - b) Teaching assistance yes/no
 - c) Computational Resources yes/no
 - d) Office hours yes/no
- 15) Would additional topics in the broad subjects below recommended?
- a) Statistics yes/no
 - b) Hydrology yes/no
 - c) Climatology yes/no
 - d) Data Science yes/no
 - e) Other _____.

Discussions

- 16) Was/were discussions _____?
- a) Aligned with the lectures yes/no
 - b) Aligned with the Labs yes/no
 - c) Relevant to the course yes/no
 - d) Irrelevant yes/no
- 17) Were the papers covered?
- a) Appropriate yes/no

- b) Key yes/no
- c) Updated yes/no
- d) Useful yes/no

18) Were discussions' formats appropriate?

- a) Presentation of a paper yes/no
- b) Roundtable yes/no
- c) Debate yes/no
- d) Useful yes/no

Labs

19) Was/were Labs _____?

- a) Aligned with the lectures yes/no
- b) Aligned with the Labs yes/no
- c) Relevant to the course yes/no
- d) Irrelevant yes/no

20) Were the subjects covered?

- a) Appropriate yes/no
- b) Key yes/no
- c) Updated yes/no
- d) Useful yes/no

21) Were Labs' tools useful?

- a) For the course yes/no
- b) For your research yes/no
- c) For your thesis yes/no

22) Were following computational tools relevant?

- a) Operative System (LINUX) yes/no
- b) Infrastructure yes/no
- c) Pre-processing/post-processing Codes yes/no
- d) Plotting codes yes/no
- e) Modeling resources yes/no

23) Was TA (Carlos Carrillo-Cruz) helpful?

- a) Knowledgeable yes/no
- b) Available yes/no
- c) Clear yes/no

24) Was TA (Daniel Rico) helpful?

- a) Knowledgeable yes/no
- b) Available yes/no
- c) Clear yes/no

Assignments and Final Project

25) Was/were Assignments and Final Projects _____?

- a) Aligned with the lectures yes/no
- b) Aligned with the Labs yes/no
- c) Relevant to the course yes/no
- d) Irrelevant yes/no

26) Was your Final Project relevant for _____?

- a) Research yes/no
- b) General interests yes/no
- c) Future work yes/no
- d) Irrelevant yes/no

27) Is your Final Project useful to write a _____?

- a) Research peer review paper yes/no
- b) General public paper yes/no
- c) Thesis yes/no
- d) Report yes/no

28) Before you took this course were you thinking about writing a _____ on the subject of your Final Project?

- a) Research peer review paper yes/no
- b) General public paper yes/no
- c) Thesis yes/no
- d) Report yes/no

NRES/METR/BSEN 479/879

Spring 2016

Questionnaire

Due: Thursday, May 12th

Undergraduate/Graduate Program Graduate
Year in the program first

This Questionnaire aims to provide feedback to the Hydroclimatology-course activities (General, Lectures, Discussions, Labs, and Assignments and Final Project).

General

- 1) Was the course helpful for your research needs?
 - a) **yes**
 - b) yes, it added a new perspective to my research
 - c) no, but I learned something new
 - d) no
- 2) What part of the course was the best for you?
 - a) Lectures
 - b) Discussions
 - c) **Labs**
 - d) Assignments
 - e) **Final project**
 - f) None
- 3) What part of the course has to be improved? (you can select fro 1 to all options)
 - a) **Lectures**
 - b) Discussions
 - c) Labs
 - d) Assignments
 - e) Final project
- 4) Was the information provided to you: _____ . Why? (Provide a brief answer in 1 to all options).
 - a) Relevant, because Provide extremely powerful informatics tools
 - b) Updated, because Recent papers analyzing key aspects
 - c) Inaccurate, because _____
 - d) Unexplained, because _____
 - e) Motivational, because _____
 - f) **Challenging**, because _____
- 5) How did you find this course?
 - a) **Advisor**
 - b) Department

- c) Committee member
 - d) My program requires it
 - e) Instructor
 - f) Email list
 - g) Class mate (friend/member of the same research group)
 - h) Previous student
- 6) Would you consider the course _____ strength/balanced/poor? (two selections per incise; 1 to 4 incises to select)
- a) Analytically strength
 - b) Computationally strength
 - c) Mathematically strength
 - d) Statistically strength
 - e) None of the above
- 7) What course(s) would be good to have as pre-requisites?
- a) Hydrology/Water Resources
 - b) Meteorology
 - c) Programing
 - d) GIS
 - e) Statistics
 - f) Numerical Methods
 - g) None of them
- 8) What is your background? (Undergraduate major and minor; and graduate program)
- Undergrad: Civil and Environmental Engineering
Grad: Environmental Engineering

- 9) What is your current undergraduate/graduate program
- PhD: Biological Systems Engineering

- 10)Based on your experience in this course (Hydroclimatology). What course(s) will you take in the fall (if is currently offered at UNL)?
- In the fall I will be very far from UNL

- 11) Based on your experience in this course (Hydroclimatology). What course(s) would you like to take (that is/are not offered by UNL)?
- a) Geostatistics
 - b) Programing for scientists and Engineers
 - c) Extreme Hydrometeorologicale and Climate Events: Diagnosis, Forecast Prediction, and Risks

- d) Risk Assessment
- e) Data science and engineering
- f) Integrated Systems Analyses

12) Based this space to provide additional feedback that was not addressed above
A potential improvement for making it perfect would be having a little more emphasis on the codes and on the labs. However, the public attending this course was coming from a different background, and therefore for some people it would be extremely difficult in this case.

Lectures

12) Was/were _____?

- a) Course sequence correct yes
- b) Course content appropriate yes
- c) Topics ' depth right yes
- d) Slides clear yes (coupled with book)

13) Was the teacher knowledgeable?

- a) Theory yes
- b) Practical experience yes
- c) Teaching yes
- d) Modeling yes
- e) Programing yes

14) Were resources available to the class enough?

- a) Course materials yes
- b) Teaching assistance yes
- c) Computational Resources yes
- d) Office hours yes

15) Would additional topics in the broad subjects below recommended?

- a) Statistics no
- b) Hydrology no
- c) Climatology no
- d) Data Science yes
- e) Programming

Discussions

16) Was/were discussions _____?

- a) Aligned with the lectures yes

- b) Aligned with the Labs yes
- c) Relevant to the course yes
- d) Irrelevant no

17) Were the papers covered?

- a) Appropriate yes
- b) Key yes
- c) Updated yes
- d) Useful yes

18) Were discussions' formats appropriate*?

- a) Presentation of a paper yes
- b) Roundtable yes
- c) Debate yes
- d) Useful yes

*I liked the discussion with the power point presentation

Labs

19) Was/were Labs _____?

- a) Aligned with the lectures yes
- b) Relevant to the course yes
- c) Irrelevant no

20) Were the subjects covered?

- a) Appropriate yes
- b) Key yes
- c) Updated yes
- d) Useful yes

21) Were Labs' tools useful?

- a) For the course yes
- b) For your research yes
- c) For your thesis yes

22) Were following computational tools relevant?

- a) Operative System (LINUX) yes
- b) Infrastructure yes
- c) Pre-processing/post-processing Codes yes
- d) Plotting codes yes
- e) Modeling resources yes

23) Was TA (Carlos Carrillo-Cruz) helpful?

- a) Knowledgeable yes
- b) Available yes
- c) Clear yes

- 24) Was TA (Daniel Rico) helpful?
- a) Knowledgeable yes
 - b) Available yes
 - c) Clear yes

Assignments and Final Project

- 25) Was/were Assignments and Final Projects _____?
- a) Aligned with the lectures yes
 - b) Aligned with the Labs yes
 - c) Relevant to the course yes
 - d) Irrelevant no
- 26) Was your Final Project relevant for _____?
- a) Research yes
 - b) General interests yes
 - c) Future work yes
 - d) Irrelevant yes
- 27) Is your Final Project useful to write a _____?
- a) Research peer review paper no
 - b) General public paper yes
 - c) Thesis yes
 - d) Report yes
- 28) Before you took this course were you thinking about writing a _____ on the subject of your Final Project?
- a) Research peer review paper no
 - b) General public paper yes
 - c) Thesis no
 - d) Report yes

NRES/METR/BSEN 479/879

Spring 2016

Questionnaire

Due: Thursday, May 12th

Undergraduate/Graduate Program _____ NRES _____.
Year in the program _____ 2nd _____.

This Questionnaire aims to provide feedback to the Hydroclimatology-course activities (General, Lectures, Discussions, Labs, and Assignments and Final Project).

General

- 1) Was the course helpful for your research needs?
 - a) **yes**
 - b) yes, it added a new perspective to my research
 - c) no, but I learned something new
 - d) no
- 2) What part of the course was the best for you?
 - a) Lectures
 - b) **Discussions**
 - c) Labs
 - d) Assignments
 - e) **Final project**
 - f) None
- 3) What part of the course has to be improved? (you can select fro 1 to all options)
 - a) **Lectures**
 - b) Discussions
 - c) Labs
 - d) Assignments
 - e) Final project
- 4) Was the information provided to you: _____ . Why? (Provide a brief answer in 1 to all options).
 - a) **Relevant, because** _____.
 - b) Updated, because _____.
 - c) Inaccurate, because _____.
 - d) Unexplained, because _____.
 - e) Motivational, because _____.
 - f) Challenging, because _____.
- 5) How did you find this course?
 - a) Advisor
 - b) Department
 - c) Committee member
 - d) My program requires it

- e) Instructor
 - f) **Email list**
 - g) Class mate (friend/member of the same research group)
 - h) Previous student
- 6) Would you consider the course _____ strength/balanced/poor? (two selections per incise; 1 to 4 incises to select)
- a) Analytically **strength**/balanced/poor (i.e. precipitation generation was properly explained)
 - b) Computationally **strength**/balanced/poor (i.e. precipitation was spatially estimated using specific coded)
 - c) Mathematically **strength**/**balanced**/poor (i.e. I developed or learn how to develop expressions to estimate precipitation)
 - d) Statistically **strength**/balanced/poor (i.e. I use statistics to evaluate the spatial distribution and/or temporal variability of precipitation)
 - e) None of the above
- 7) What course(s) would be good to have as pre-requisites?
- a) **Hydrology/Water Resources**
 - b) **Meteorology**
 - c) Programing
 - d) GIS
 - e) Statistics
 - f) Numerical Methods
 - g) None of them
- 8) What is your background? (Undergraduate major and minor; and graduate program)

Meteorology Science

- 9) What is your current undergraduate/graduate program

NRES

- 10)Based on your experience in this course (Hydroclimatology). What course(s) will you take in the fall (if is currently offered at UNL)?

Land Atmosphere interaction

- 11) Based on your experience in this course (Hydroclimatology). What course(s) would you like to take (that is/are not offered by UNL)?

- a) **Geostatistics**
- b) **Programing for scientists and Engineers**
- c) **Extreme Hydrometeorologica and Climate Events: Diagnosis, Forecast Prediction, and Risks**
- d) Risk Assessment
- e) Data science and engineering
- f) Integrated Systems Analyses

11) Based this space to provide additional feedback that was not addressed above

- The lab topics covered at the end were really great but at the same time involve concepts that are relatively harder. I personally feel it would have been great if they have been given the same weight as the preceding lab sessions.

Lectures

12) Was/were _____?

- a) Course sequence correct yes/no
- b) Course content appropriate yes/no
- c) Topics ' depth right yes/no
- d) Slides clear yes/no but at some point the lecture material seem to match and difficult to follow

13) Was the teacher knowledgeable?

- a) Theory yes/no!!
- b) Practical experience yes/no
- c) Teaching yes/no
- d) Modeling yes/no
- e) Programing yes/no

14) Were resources available to the class enough?

- a) Course materials yes/no
- b) Teaching assistance yes/no Highly appreciated
- c) Computational Resources yes/no
- d) Office hours yes/no

15) Would additional topics in the broad subjects below recommended?

- a) Statistics yes/no [to make lab sessions like EOF analysis to be a bit easier]
- b) Hydrology yes/no
- c) Climatology yes/no
- d) Data Science yes/no
- e) Other _____.

Discussions

16) Was/were discussions _____?

- a) Aligned with the lectures yes/no
- b) Aligned with the Labs yes/no
- c) Relevant to the course yes/no

d) Irrelevant yes/no

17) Were the papers covered?

a) Appropriate yes/no

b) Key yes/no

c) Updated yes/no

d) Useful yes/no

18) Were discussions' formats appropriate?

a) Presentation of a paper yes/no

b) Roundtable yes/no

c) Debate yes/no

d) Useful yes/no

Labs

19) Was/were Labs_____?

a) Aligned with the lectures yes/no

b) Aligned with the Labs yes/no

c) Relevant to the course yes/no

d) Irrelevant yes/no

20) Were the subjects covered?

a) Appropriate yes/no

b) Key yes/no

c) Updated yes/no

d) Useful yes/no

21) Were Labs' tools useful?

a) For the course yes/no

b) For your research yes/no

c) For your thesis yes/no

22) Were following computational tools relevant?

a) Operative System (LINUX) yes/no

b) Infrastructure yes/no

c) Pre-processing/post-processing Codes yes/no

d) Plotting codes yes/no

e) Modeling resources yes/no

23) Was TA (Carlos Carrillo-Cruz) helpful?

a) Knowledgeable yes/no

b) Available yes/no

c) Clear yes/no

Great person!!!!Passionate about the subject. Glad that I met him and would be looking forward to interact with him even after the course.

24) Was TA (Daniel Rico) helpful?

a) Knowledgeable yes/no

- b) Available yes/no
- c) Clear yes/no

Assignments and Final Project

25) Was/were Assignments and Final Projects _____?

- a) Aligned with the lectures yes/no
- b) Aligned with the Labs yes/no
- c) Relevant to the course yes/no
- d) Irrelevant yes/no

26) Was your Final Project relevant for _____?

- a) Research yes/no
- b) General interests yes/no
- c) Future work yes/no
- d) Irrelevant yes/no

27) Is your Final Project useful to write a _____?

- a) Research peer review paper yes/no
- b) General public paper yes/no
- c) Thesis yes/no
- d) Report yes/no

28) Before you took this course were you thinking about writing a _____ on the subject of your Final Project?

- a) Research peer review paper yes/no
- b) General public paper yes/no
- c) Thesis yes/no
- d) Report yes/no

NRES/METR/BSEN 479/879

Spring 2016

Questionnaire

Due: Thursday, May 12th

Undergraduate/**Graduate** Program _____.
Year in the program 1.

This Questionnaire aims to provide feedback to the Hydroclimatology-course activities (General, Lectures, Discussions, Labs, and Assignments and Final Project).

General

- 1) Was the course helpful for your research needs?
 - a) **yes**
 - b) **yes, it added a new perspective to my research**
 - c) no, but I learned something new
 - d) no
- 2) What part of the course was the best for you?
 - a) Lectures
 - b) Discussions
 - c) **Labs**
 - d) Assignments
 - e) Final project
 - f) None
- 3) What part of the course has to be improved? (you can select fro 1 to all options)
 - a) Lectures
 - b) Discussions
 - c) Labs
 - d) **Assignments**
 - e) Final project
- 4) Was the information provided to you: _____ . Why? (Provide a brief answer in 1 to all options).
 - a) Relevant, because it is related to my project
 - b) Updated, because _____
 - c) Inaccurate, because _____
 - d) Unexplained, because _____
 - e) Motivational, because _____
 - f) Challenging, because _____
- 5) How did you find this course?
 - a) **Advisor**
 - b) Department
 - c) Committee member

- d) My program requires it
 - e) Instructor
 - f) Email list
 - g) Class mate (friend/member of the same research group)
 - h) Previous student
- 6) Would you consider the course _____ strength/balanced/poor? (two selections per incise; 1 to 4 incises to select)
- a) Analytically **strength**/balanced/poor (i.e. precipitation generation was properly explained)
 - b) **Computationally strength**/balanced/poor (i.e. precipitation was spatially estimated using specific coded)
 - c) **Mathematically strength**/balanced/poor (i.e. I developed or learn how to develop expressions to estimate precipitation)
 - d) **Statistically strength**/balanced/poor (i.e. I use statistics to evaluate the spatial distribution and/or temporal variability of precipitation)
 - e) None of the above
- 7) What course(s) would be good to have as pre-requisites?
- a) **Hydrology/Water Resources**
 - b) **Meteorology**
 - c) Programing
 - d) GIS
 - e) **Statistics**
 - f) Numerical Methods
 - g) None of them
- 8) What is your background? (Undergraduate major and minor; and graduate program)
- I had Geography BS degree, and GIS certificate
- 9) What is your current undergraduate/graduate program
- I am pursuing master degree in Geography
- 10)Based on your experience in this course (Hydroclimatology). What course(s) will you take in the fall (if is currently offered at UNL)?
- 11) Based on your experience in this course (Hydroclimatology). What course(s) would you like to take (that is/are not offered by UNL)?
- a) **Geostatistics**
 - b) Programing for scientists and Engineers
 - c) Extreme Hydrometeorological and Climate Events: Diagnosis, Forecast Prediction, and Risks
 - d) **Risk Assessment**
 - e) Data science and engineering

f) Integrated Systems Analyses

11) Based this space to provide additional feedback that was not addressed above

Lectures

12) Was/were _____?

- a) Course sequence correct yes/no
- b) Course content appropriate yes/no
- c) Topics ' depth right yes/no
- d) Slides clear yes/no

13) Was the teacher knowledgeable?

- a) Theory yes/no
- b) Practical experience yes/no
- c) Teaching yes/no
- d) Modeling yes/no
- e) Programing yes/no

14) Were resources available to the class enough?

- a) Course materials yes/no
- b) Teaching assistance yes/no
- c) Computational Resources yes/no
- d) Office hours yes/no

15) Would additional topics in the broad subjects below recommended?

- a) Statistics yes/no
- b) Hydrology yes/no
- c) Climatology yes/no
- d) Data Science yes/no
- e) Other _____.

Discussions

16) Was/were discussions _____?

- a) Aligned with the lectures yes/no
- b) Aligned with the Labs yes/no
- c) Relevant to the course yes/no
- d) Irrelevant yes/no

17) Were the papers covered?

- a) Appropriate yes/no

- b) Key yes/no
- c) Updated yes/no
- d) Useful yes/no

18) Were discussions' formats appropriate?

- a) Presentation of a paper yes/no
- b) Roundtable yes/no
- c) Debate yes/no
- d) Useful yes/no

Labs

19) Was/were Labs _____?

- a) Aligned with the lectures yes/no
- b) Aligned with the Labs yes/no
- c) Relevant to the course yes/no
- d) Irrelevant yes/no

20) Were the subjects covered?

- a) Appropriate yes/no
- b) Key yes/no
- c) Updated yes/no
- d) Useful yes/no

21) Were Labs' tools useful?

- a) For the course yes/no
- b) For your research yes/no
- c) For your thesis yes/no

22) Were following computational tools relevant?

- a) Operative System (LINUX) yes/no
- b) Infrastructure yes/no
- c) Pre-processing/post-processing Codes yes/no
- d) Plotting codes yes/no
- e) Modeling resources yes/no

23) Was TA (Carlos Carrillo-Cruz) helpful?

- a) Knowledgeable yes/no
- b) Available yes/no
- c) Clear yes/no

24) Was TA (Daniel Rico) helpful?

- a) Knowledgeable yes/no
- b) Available yes/no
- c) Clear yes/no

Assignments and Final Project

25) Was/were Assignments and Final Projects _____?

- a) Aligned with the lectures yes/no
- b) Aligned with the Labs yes/no
- c) Relevant to the course yes/no
- d) Irrelevant yes/no

26) Was your Final Project relevant for _____?

- a) Research yes/no
- b) General interests yes/no
- c) Future work yes/no
- d) Irrelevant yes/no

27) Is your Final Project useful to write a _____?

- a) Research peer review paper yes/no
- b) General public paper yes/no
- c) Thesis yes/no
- d) Report yes/no

28) Before you took this course were you thinking about writing a _____ on the subject of your Final Project?

- a) Research peer review paper yes/no
- b) General public paper yes/no
- c) Thesis yes/no
- d) Report yes/no

Appendix 10

Lincoln NE. October 13th 2015

Biological Systems Engineering Undergraduate Curriculum Committee
PRESENT

Dear Colleagues:

The present letter synthesizes the justification of why I request to cross-list NRES/METEO 479/879 Hydroclimatology with BSEN 479/879.

JUSTIFICATION

A changing climate within one year or a century forces the availability of water around the world at multiple spatial scales, contributing to sustain our food and energy production, as well as the ecosystem services. On the other hand, water is a key driver of weather and climate systems. These interdependencies between climate and water have become critical for water resources, irrigation and environmental engineers since the principle of stationarity is no longer valid. Thus, our undergraduate and graduate students will be benefited from an understanding of the principles that define the water and climate systems' interdependence within physical, biological/biogeochemical, and socioeconomic contexts. Therefore, this course will be important for senior students who have taken irrigation and advanced irrigation, soil and water resources engineering, as well as groundwater engineering courses. In this context, the companion document contains the syllabus for the course Hydroclimatology (currently NRES 479/879 and METR 479/879). This course's home is SNR and I suggest it to be cross-listed as BSEN 479/879. I aim to teach this course every other spring semester, starting in 2016.

Please, feel free to contact me if you need me to clarify or expand my description of this case.

Sincerely

Francisco

Assistant Professor in Hydroinformatics and Integrated Hydrology
Biological Systems Engineering Department
Courtesy appointments in the School of Natural Resources and Earth and
Atmospheric Sciences Department

Appendix 11

Close

Web of Science™
Page 1 (Records 1 -- 10)

Print

◀ [1] ▶

Record 1 of 10**By:** Regonda, SK (Regonda, SK); Rajagopalan, B (Rajagopalan, B); Clark, M (Clark, M); Pitlick, J (Pitlick, J)**Title:** Seasonal cycle shifts in hydroclimatology over the western United States**Source:** JOURNAL OF CLIMATE**Volume:** 18**Issue:** 2**Pages:** 372-384**DOI:** 10.1175/JCLI-3272.1**Published:** JAN 15 2005**Accession Number:** WOS:000227141900008

Record 2 of 10**By:** Yeh, PJF (Yeh, PJF); Irizarry, M (Irizarry, M); Eltahir, EAB (Eltahir, EAB)**Title:** Hydroclimatology of Illinois: A comparison of monthly evaporation estimates based on atmospheric water balance and soil water balance**Source:** JOURNAL OF GEOPHYSICAL RESEARCH-ATMOSPHERES**Volume:** 103**Issue:** D16**Pages:** 19823-19837**DOI:** 10.1029/98JD01721**Published:** AUG 27 1998**Accession Number:** WOS:000075595400029

Record 3 of 10**By:** Lins, HF (Lins, HF)**Title:** Regional streamflow regimes and hydroclimatology of the United States**Source:** WATER RESOURCES RESEARCH**Volume:** 33**Issue:** 7**Pages:** 1655-1667**DOI:** 10.1029/97WR00615**Published:** JUL 1997**Accession Number:** WOS:A1997XG95800012

Record 4 of 10**By:** Gochis, DJ (Gochis, DJ); Brito-Castillo, L (Brito-Castillo, L); Shuttleworth, WJ (Shuttleworth, WJ)**Title:** Hydroclimatology of the North American Monsoon region in northwest Mexico**Source:** JOURNAL OF HYDROLOGY**Volume:** 316**Issue:** 1-4**Pages:** 53-70**DOI:** 10.1016/j.jhydrol.2005.04.021**Published:** JAN 10 2006**Accession Number:** WOS:000234275900005

Record 5 of 10**By:** Sankarasubramanian, A (Sankarasubramanian, A); Vogel, RM (Vogel, RM)**Title:** Annual hydroclimatology of the United States**Source:** WATER RESOURCES RESEARCH**Volume:** 38**Issue:** 6**Article Number:** 1083**DOI:** 10.1029/2001WR000619**Published:** JUN 2002**Accession Number:** WOS:000178936000013

Record 6 of 10**By:** Sankarasubramanian, A (Sankarasubramanian, A); Vogel, RM (Vogel, RM)**Title:** Hydroclimatology of the continental United States**Source:** GEOPHYSICAL RESEARCH LETTERS**Volume:** 30**Issue:** 7**Article Number:** 1363**DOI:** 10.1029/2002GL015937**Published:** APR 3 2003**Accession Number:** WOS:000182236100001

Record 7 of 10**By:** Oguntunde, PG (Oguntunde, Philip G.); Friesen, J (Friesen, Jan); De Giesen, NV (De Giesen, Nick van); Savenije, HHG (Savenije, Hubert H. G.)**Title:** Hydroclimatology of the Volta river basin in west Africa: trends and variability from 1901 to 2002**Source:** PHYSICS AND CHEMISTRY OF THE EARTH**Volume:** 31**Issue:** 18**Pages:** 1180-1188**DOI:** 10.1016/j.pce.2006.02.062**Published:** 2006**Conference Title:** Meeting of the European-Union-of-Geosciences**Conference Date:** APR 24-29, 2005**Conference Location:** Vienna, AUSTRIA**Sponsor(s):** European Geosci Union**Accession Number:** WOS:000243446500009**Record 8 of 10****By:** GEORGAKAKOS, KP (GEORGAKAKOS, KP); BAE, DH (BAE, DH); CAYAN, DR (CAYAN, DR)**Title:** HYDROCLIMATOLOGY OF CONTINENTAL WATERSHEDS .1. TEMPORAL ANALYSES**Source:** WATER RESOURCES RESEARCH**Volume:** 31**Issue:** 3**Pages:** 655-675**DOI:** 10.1029/94WR02375**Published:** MAR 1995**Accession Number:** WOS:A1995QL42700018**Record 9 of 10****By:** Cannon, AJ (Cannon, Alex J.)**Title:** A flexible nonlinear modelling framework for nonstationary generalized extreme value analysis in hydroclimatology**Source:** HYDROLOGICAL PROCESSES**Volume:** 24**Issue:** 6**Pages:** 673-685**DOI:** 10.1002/hyp.7506**Published:** MAR 15 2010**Accession Number:** WOS:000276161000001**Record 10 of 10****By:** Mohamed, YA (Mohamed, YA); van den Hurk, BJJM (van den Hurk, BJJM); Savenije, HHG (Savenije, HHG); Bastiaanssen, WGM (Bastiaanssen, WGM)**Title:** Hydroclimatology of the Nile: results from a regional climate model**Source:** HYDROLOGY AND EARTH SYSTEM SCIENCES**Volume:** 9**Issue:** 3**Pages:** 263-278**Published:** 2005**Accession Number:** WOS:000232758700010[Close](#)Web of Science™
Page 1 (Records 1 -- 10)[Print](#)

◀ [1] ▶

Close

Print

◀ [1] ▶

Record 1 of 10

Abstract: Analyses of streamflow, snow mass temperature and precipitation in snowmelt-dominated river basins in the western United States indicate an advance in the timing of peak spring season flows over the past 50 years. Warm temperature spells in spring have occurred much earlier in recent years, which explains in part the trend in the timing of the spring peak flow. In addition, a decrease in snow water equivalent and a general increase in winter precipitation are evident for many stations in the western United States. It appears that in recent decades more of the precipitation is coming as rain rather than snow. The trends are strongest at lower elevations and in the Pacific Northwest region, where winter temperatures are closer to the melting point; it appears that in this region in particular, modest shifts in temperature are capable of forcing, large shifts in basin hydrologic response. It is speculated that these trends could be potentially a manifestation of the general global warming, trend in recent decades and also due to enhanced ENSO activity. The observed trends in hydroclimatology over the western United States can have significant impacts on water resources planning and management.

Accession Number: WOS:000227141900008

Record 2 of 10

Abstract: Here we describe the regional-scale hydrological cycle of Illinois, including both the land and atmospheric branches, using a data set on most of the hydrological variables, i.e., precipitation, streamflow, soil water content, snow depth, groundwater level, and atmospheric flux of water vapor. Since direct observations of evaporation are not available, two different approaches, soil water balance and atmospheric water balance, were applied to estimate the regional evaporation over Illinois from 1983 to 1994. The availability of a comprehensive hydrological data set covering the large area of Illinois facilitated a comparison between these two approaches for estimation of evaporation. To our knowledge, this is the first time such a comparison has been made. The climatologies of the monthly evaporation estimates from the two approaches agree reasonably well and within a 10% error; however, substantial differences exist between the two estimates of evaporation for individual months. The seasonal variability of the evaporation estimates based on soil water balance is largely balanced by the seasonal pattern of subsurface storage, whereas the seasonal variability of evaporation estimates from the atmospheric water balance is almost entirely balanced by the seasonal pattern of lateral fluxes of water vapor. This contrast reflects a fundamental difference in the hydrology of the land and atmospheric branches of the regional water cycle. In light of the fact that independent data sets were used in the two approaches, our results are encouraging: The atmospheric water balance approach has the potential for the accurate estimation of the climatology of regional evaporation, at least for humid regions at a scale similar to that of Illinois (similar to 10(5) km²). However, sensitivity analysis suggests that the accuracy of atmospheric water balance computations is rather poor for the scale smaller than 10(5) km². For the calculation of evaporation using the soil water balance approach in regions where the groundwater table is rather shallow, the incorporation of the change in groundwater storage is indispensable since groundwater aquifers provide a significant portion of water storage at the monthly timescale.

Accession Number: WOS:000075595400029

Record 3 of 10

Abstract: The dominant regions of interannual streamflow variability in the United States are defined, and their seasonality and persistence characteristics identified, using an orthogonally rotated principal components analysis (RPCA) of a climatically sensitive network of 559 stream gages for the period 1941-1988. This classification of streamflow regimes is comprehensive and unique in that separate analyses of the streamflow record, for each month of the year, are carried out to detail the month-to-month changes in the dominant streamflow patterns. Streamflow variations, or anomalies, in the Upper Mississippi, South Atlantic/Gulf, Far West, Ohio Valley, Northeast, and Eastern/Mid-Atlantic regions, as well as a pattern of opposing streamflow anomalies in the West, are observed in all seasons of the year. Anomalies in the Southern Plains and New England regions are observed in autumn, winter, and spring; those in the Rocky Mountains and Middle Mississippi regions occur in late spring and summer.

Accession Number: WOS:A1997XG95800012

Record 4 of 10

Abstract: The North American Monsoon (NAM) system controls the warm season climate over much of southwestern North America. In this semi-arid environment, understanding the regional behavior of the hydroclimatology and its associated modes of variability is critically important to effectively predicting and managing perpetually stressed regional water resources. Equally as important is understanding the relationships through which warm season precipitation is converted into streamflow. This work explores the hydroclimatology of northwestern Mexico, i.e. the core region of the NAM, by (a) presenting a thorough review of recent hydroclimatic investigations from the region and (b) developing a detailed hydroclimatology of 15, unregulated, headwater basins along the Sierra Madre Occidental mountains in western Mexico. The present work is distinct from previous studies as it focuses on the intra-seasonal evolution of rainfall-runoff relationships, and contrasts the sub-regional behavior of the rainfall-runoff response. It is found that there is substantial sub-regional coherence in the hydrological response to monsoon precipitation. Three physically plausible regions emerge from a rotated Principal Components Analysis of streamflow and basin-averaged precipitation. Mouth-to-mouth streamflow persistence, rainfall-runoff correlation scores and runoff coefficient values demonstrate regional coherence and are generally consistent with what is currently known about subregional aspects of NAM precipitation character. (c) 2005 Elsevier B.V. All rights reserved.

Accession Number: WOS:000234275900005

Record 5 of 10

Abstract: [1] An overview of the annual hydroclimatology of the United States is provided. Time series of monthly streamflow, temperature, and precipitation are developed for 1337 watersheds in the United States. This unique data set is then used to evaluate several approaches for estimating the long-term water balance and the interannual variability of streamflow. Traditional relationships which predict either actual evapotranspiration or the interannual variability of streamflow from an aridity index $\phi = (PE) / \bar{P}$ over \bar{P} are shown to perform poorly for basins with low soil moisture storage capacity. A water balance model is used to formulate new relationships for predicting actual evapotranspiration and the interannual variability of streamflow. These relationships depend on both the aridity index $\phi = (PE) / \bar{P}$ over \bar{P} and a new soil moisture storage index. A physically based approach for estimating the soil moisture storage index is introduced which requires monthly time series of precipitation, potential evapotranspiration, and an estimate of maximum soil moisture holding capacity. The net results are improved expressions for the long-term water balance and the interannual variability of streamflow which do not require either calibration or streamflow data.

Accession Number: WOS:000178936000013

Record 6 of 10

Abstract: [1] The overall water balance and the sensitivity of watershed runoff to changes in climate are investigated using national databases of climate and streamflow for 1,337 watersheds in the U. S. We document that 1% changes in precipitation result in 1.5-2.5% changes in watershed runoff, depending upon the degree of buffering by storage processes and other factors. Unlike previous research, our approach to estimating climate sensitivity of streamflow is nonparametric and does not depend on a hydrologic model. The upper bound for precipitation elasticity of streamflow is shown to be the inverse of the runoff ratio. For over a century, investigators [Pike, 1964; Budyko, 1974; O'ledek, 1911; and Schreiber, 1904] have suggested that variations in watershed aridity alone are sufficient to predict spatial variations in long-term watershed runoff. We document that variations in soil moisture holding capacity are just as important as variations in watershed aridity in explaining the mean and variance of annual watershed runoff.

Accession Number: WOS:000182236100001

Record 7 of 10

Abstract: Long-term historical records of rainfall (P), runoff (Q) and other climatic factors were used to investigate hydrological variability and trends in the Volta River Basin over the period 1901-2002. Potential (E-P) and actual evaporation (E), rainfall variability index (delta), Budyko's aridity index (I-A), evaporation ratio (C-E) and runoff ratio (CO) were estimated from the available hydroclimatological records. Mann-Kendall trend analysis and non-parametric Sen's slope estimates were performed on the respective time series variables to detect monotonic trend direction and magnitude of change over time. Rainfall variability index showed that 1968 was the wettest year (delta = +1.75) while 1983 was the driest (delta = -3.03), with the last three decades being drier than any other comparable period in the hydrological history of the Volta. An increase of 0.2 mm/yr(2) (P < 0.05) was observed in E-P for the 1901-1969 sub-series while an increased of 1.8 mm/yr(2) (P < 0.01) was recorded since 1970. Rainfall increased at the rate of 0.7 mm/yr(2) or 49 mm/yr between 1901 and 1969, whereas a decrease of 0.2 mm/yr(2) (6 mm/yr) was estimated for 1970-2002 sub-series. Runoff increased significantly at the rate of 0.8 mm/yr (23 mm/yr) since 1970. Runoff before dam construction was higher (87.5 mm/yr) and more varied (CV = 41.5%) than the post-dam period with value of 73.5 mm/yr (CV = 23.9%). A 10% relative decrease in P resulted in a 16% decrease in Q between 1936 and 1998. Since 1970, all the months showed increasing runoff trends with significant slopes (P < 0.05) in 9 out of the 12 months. Possible causes, such as climate change and land cover change, on the detected changes in hydroclimatology are briefly discussed. (c) 2006 Published by Elsevier Ltd.

Accession Number: WOS:000243446500009

Record 8 of 10

Abstract: The linkage between meteorology/climate and hydrology of temperate latitude catchments on daily to decade time scales is studied. Detailed hydrology is provided by a hydrologic catchment model, adapted from the operational streamflow forecast model of the National Weather Service River Forecast System. The model is tuned to respond to observed daily precipitation and potential evaporation input. Results from the Bird Creek basin with outlet near Sperry, Oklahoma, and from the Boone River basin with outlet at Webster City, Iowa, indicate that the model quite accurately simulates the observed daily discharge over 40 years at each of the two 2000-km(2) basins. Daily cross-correlations between observed and simulated basin outflows were better than 0.8 for both basins over a 40-year historical period. Soil moisture variability over a period of four decades is studied, and an assessment of temporal and spatial (as related to the separation distance of the two basins) scales present in the estimated soil moisture record is made. Negative soil. water anomalies have larger magnitudes than positive anomalies, and comparison of the simulated soil water records of the two basins indicates spatial scales of variability that in several cases are as long as the interbasin distance. The temporal scales of soil water content are considerably longer than those of the forcing atmospheric variables for all seasons and both basins. Timescales of upper and total soil water content anomalies are typically 1 and 3 months, respectively. Linkage between the hydrologic components and both local and regional-to-hemispheric atmospheric variability is studied, both for atmosphere forcing hydrology and hydrology forcing atmosphere. For both basins, crosscorrelation analysis shows that local precipitation strongly forces soil water in the upper soil layers with a 10-day lag. There is no evidence of soil water feedback to local precipitation. However, significant cross-correlation values are obtained for upper soil water leading daily maximum temperature with 5-10 day lags, especially during periods of extremely high or low soil water content. Complementary results of a spatial hydroclimatic analysis are presented in a companion paper (Cayan and Georgakakos, this issue).

Accession Number: WOS:A1995QL42700018

Record 9 of 10

Abstract: Parameters in a generalized extreme value (GEV) distribution are specified as a function of covariates using a conditional density network (CDN), which is a probabilistic extension of the multilayer perceptron neural network. If the covariate is time or is dependent on time, then the GEV-CDN model can be used to perform nonlinear, nonstationary GEV analysis of hydrological or climatological time series. Owing to the flexibility of the neural network architecture, the model is capable of representing a wide range of nonstationary relationships. Model parameters are estimated by generalized maximum likelihood, an approach that is tailored to the estimation of GEV parameters from geophysical time series. Model complexity is identified using the Bayesian information criterion and the Akaike information criterion with small sample size correction. Monte Carlo simulations are used to validate GEV-CDN performance on four simple synthetic problems. The model is then demonstrated on precipitation data from southern California, a series that exhibits nonstationarity due to interannual/interdecadal climatic variability. Copyright (C) 2009 Her Majesty the Queen in right of Canada. Published by John Wiley & Sons. Ltd

Accession Number: WOS:000276161000001

Record 10 of 10

Abstract: This paper presents the result of the regional coupled climatic and hydrologic model of the Nile Basin. For the first time the interaction between the climatic processes and the hydrological processes on the land surface have been fully coupled. The hydrological model is driven by the rainfall and the energy available for evaporation generated in the climate model, and the runoff generated in the catchment is again routed over the wetlands of the Nile to supply moisture for atmospheric feedback. The results obtained are quite satisfactory given the extremely low runoff coefficients in the catchment. The paper presents the validation results over the subbasins: Blue Nile, White Nile, Atbara river, the Sudd swamps, and the Main Nile for the period 1995 to 2000. Observational datasets were used to evaluate the model results including radiation, precipitation, runoff and evaporation data. The evaporation data were derived from satellite images over a major part of the Upper Nile. Limitations in both the observational data and the model are discussed. It is concluded that the model provides a sound representation of the regional water cycle over the Nile. The sources of atmospheric moisture to the basin, and location of convergence/divergence fields could be accurately illustrated. The model is used to describe the regional water cycle in the Nile basin in terms of atmospheric fluxes, land surface fluxes and land surface-climate feedbacks. The monthly moisture recycling ratio (i.e. locally generated/total precipitation) over the Nile varies between 8 and 14%, with an annual mean of 11%, which implies that 89% of the Nile water resources originates from outside the basin physical boundaries. The monthly precipitation efficiency varies between 12 and 53%, and the annual mean is 28%. The mean annual result of the Nile regional water cycle is compared to that of the Amazon and the Mississippi basins.

Accession Number: WOS:000232758700010

Close

Web of Science™
Page 1 (Records 1 -- 10)

Print

◀ [1] ▶