

Technical mathematics in the University of Debrecen

Rita Nagy-Kondor

Faculty of Engineering, University of Debrecen
rita@eng.unideb.hu

Submitted September 13, 2011 Accepted October 25, 2011

Abstract

The presented course book has been written for the lectures and seminars of the subject Mathematics I, which is in the syllabus of the Faculty of Engineering, University of Debrecen. The book has an unusual approach to the curriculum in mathematics. Although the topics follow the usual thematic of the subject, the aim is not the teaching of mathematical concepts and tools, but the demonstration of their application in different engineering and economic fields, where the students will meet them. In this paper, we report on our experiences of this teaching method and on the application of the book.

Keywords: Engineering application, mathematical tools

1. Introduction

In the University of Debrecen Faculty of Engineering – similarly to many higher education institutes – the difficulties of the mass education come forward. Beside the increase of the number of the students, the number of the full-time teachers decreased. For measuring the high school mathematics knowledge of the students we make the first year students to write a test, according to that we can say that in the previous knowledge of our students there are big differences. One part of them cannot meet the earlier created requirement system, cannot bring in his lag.

So many traditional mathematics course book was made in the last years in the Faculty of Engineering, University of Debrecen, which contains the basic mathematics substance. By the experience of the education the authors made decision: some important applications of the mechanics, physics, and economics need to be built into the substance of lectures and practices of mathematics.

The authors have given an answer to the problem, and created a course book – entitled “Mathematical tools in engineering applications” [6] – in which the exercises are related to real technical problems. This way the students can realize that learning mathematics is useful, because they can see the extended application of mathematics in several engineering fields. Our approach emphasises why it is so important to learn mathematical methods and concepts, and where and how they can be applied.

This article reports on this teaching method and on the application of the book. Some problems of teaching mathematics are presented in Section 2. The first part of the course book has already been published; the content of it is reviewed in Section 3. The new method has already been applied in two semesters [5]; the experiences are presented in Section 4.

2. Motivation

International surveys show that the average Hungarian student loses 90% of his mathematical knowledge in the first three years after graduating from secondary school [11].

In the last few years a lot of publications reported on the rapid decreasing of the mathematical knowledge – and in general the educational level – of students in higher education [4] [7] [12]. Our experience is the same. It is also alarming that the skill to apply mathematics and the fundamental mathematical knowledge of graduated engineers show a decline. Sutherland and Pozzi [8] reporting: “There is unprecedented concern amongst mathematicians, scientists and engineers in higher education about the mathematical preparedness of new undergraduates”. The situation has not changed since. They identified two main reasons:

- broadening of college and university entrance requirements to enable students to enter through vocational or other non traditional routes,
- the curriculum changes in students’ pre-university education.

Teachers dealing with Mathematics have probably had the experience that most students find this subject hard. If they meet a new type of exercise that is a little bit different from the ones they practised you can easily see that their knowledge is superficial. But at the applied level of abstraction less and less student can receive the necessary knowledge. Mathematics works with abstract concepts. This fact makes the learning of it hard and time consuming. But the knowledge and understanding of concepts is vital for students to be able to build up their knowledge. By now the situation has changed, and it has become clear that the traditional teaching methods have to be reformed, because they are insufficient for handling the situation.

European technical universities tried out some potential solutions [1] [2] [3]:

- reducing mathematics syllabus: this made the drastic decrease of the high outstanding students’ number.

- developing additional units: the students' loability is low so this gave few results.
- establishing mathematics support centres: but it turned that students with incomplete knowledge would need regular and extensive knowledge replacement.

Each of these has its own disadvantages.

Thus we found it vital to rethink the teaching of mathematics at our Faculty. [9] [10] We have approached the problem from two points of view.

First, we found it essential to summarise and repeat that part of secondary school mathematics and physics which is necessary as basic knowledge at our Faculty of Engineering. Besides, we intended to improve the logical way of thinking and problem solving ability of students. As a result, we introduced the compulsory subject "Basics of Natural Sciences". On the other hand, the teaching of Mathematics I. is based on our new course book, the title of which is "Mathematical Tools in Engineering Applications". That book follows a new approach and uses problems typically occurring in the fields of engineering and economics. However, it is important to note that in spite of the theoretical chapters that were written to clarify the basic concepts and problems of the engineering or economic field it should still be considered a course book of Mathematics, as the main purpose of the book is to help students understand this subject. This can only be realized by simplifying the engineering and economic problems to an appropriate level, so these kinds of problems will not make it more difficult for the students to receive the necessary mathematical knowledge. We hope, that with the didactically well-thought-out usage of this way the level of acquirement of the Mathematics increases. From the teacher's point of view the usage of the system increases the time period that is needed to get prepared for the classes.

3. Mathematical tools in engineering applications

In the course book "Mathematical Tools in Engineering Applications" the topics follow the usual thematic of the subject, the aim is not the teaching of mathematical concepts and tools, but the demonstration of their application in different engineering and economic fields, where the students will meet them.

Our main goals are to help the students to meet the requirements of the curriculum and have a more thorough understanding of Mathematics. We also wish to meet the demands of mass education. We would also like to help our students prepare for MSc level education, as according to our survey, 31% of our students wish to continue their studies after graduation.

The 8 chapters of the course book can be divided into groups of exercises. Each group of exercises starts with a theoretical summary, which provides a brief, but concise and professionally adequate description of the given engineering field. This is followed by a sample exercise with its solution and a series of similar exercises.

Main topics: Plane geometry, Space geometry, Vector algebra, Plane coordinate geometry, Complex numbers, Matrices. Linear functions and transformations, Systems of linear equations. The properties and graph of basic functions.

Figure 1 shows the different subchapters (which refer to the applications) within the main topics. (Engineering Mechanics I = Statics I; Engineering Mechanics II = Statics II; Engineering Mechanics III = Kinematics and Kinetics)

| | | | |
|--|----|--|----|
| 1. PLANE GEOMETRY | 7 | 6. MATRICES, LINEAR FUNCTIONS AND TRANSFORMATIONS | 47 |
| 1.1 GEOMETRY OF IN-PLANE STRUCTURES (ENGINEERING MECHANICS I-II-III) | 7 | 6.1 STATE OF STRESS (ENGINEERING MECHANICS II) | 47 |
| 1.2 THE MASS AND WEIGHT OF PLATES (ENGINEERING MECHANICS I-II-III) | 9 | 6.2 STATE OF STRAIN GENERAL HOOKE'S LAW (ENGINEERING MECHANICS II) | 56 |
| 2. SPACE GEOMETRY | 12 | 7. SYSTEM OF LINEAR EQUATIONS | 69 |
| 2.1 GEOMETRY OF SPACE STRUCTURES (ENGINEERING MECHANICS I-II-III) | 12 | 7.1 CALCULATIONS IN DC CIRCUITS (ELECTRICAL ENGINEERING) | 69 |
| 2.2 GEOMETRY OF BUILDINGS AND ENGINEERING STRUCTURES (BUILDING ENGINEERING PRACTICE) | 14 | 7.2 CALCULATION OF THE COORDINATES AND LINE OF ACTION OF UNKNOWN FORCES IN A BALANCED FORCE SYSTEM (ENGINEERING MECHANICS I) | 75 |
| 2.3 MASS AND SURFACE AREA OF BODIES (ENGINEERING MECHANICS I-II-III) | 16 | 8. BASIC CALCULUS, BASIC PROPERTIES AND PLOTTING OF REAL FUNCTIONS. | 79 |
| 3. VECTOR ALGEBRA | 20 | 8.1 PROCESSES OF IDEAL GAS (THERMO-AND HYDRODYNAMICS) | 79 |
| 3.1 FORCES AND THEIR RESULTANT, EQUILIBRIUM OF A PARTICLE (ENGINEERING MECHANICS I-II-III) | 20 | 8.2 KINEMATICS OF VIBRATIONS (ENGINEERING MECHANICS III) | 84 |
| 3.2 TORQUE, EQUILIBRIUM OF RIGID BODIES (ENGINEERING MECHANICS I-II-III) | 25 | 8.3 ECONOMICS (MACROECONOMICS) | 92 |
| 4. PLANE COORDINATE GEOMETRY | 29 | | |
| 4.1 THE RESULTANT OF A PLANE FORCE SYSTEM (ENGINEERING MECHANICS I-II-III) | 29 | | |
| 4.2 THE POSITION-TIME FUNCTION AND TRACK OF A PARTICLE (ENGINEERING MECHANICS III) | 35 | | |
| 5. COMPLEX NUMBERS | 41 | | |
| 5.1 CALCULATIONS IN AC CIRCUITS (ELECTRICAL ENGINEERING) | 41 | | |

Figure 1

In the following we present two exercises as examples from three different chapters. The titles of these chapters are: Plane geometry (Exercise group: "The geometric relations of plane structures") and Vector algebra (Exercise group: "Forces and their resultant. Equilibrium of a particle").

Example 3.1. The figure below shows a crank-mechanism. Calculate distance. (Figure 2)

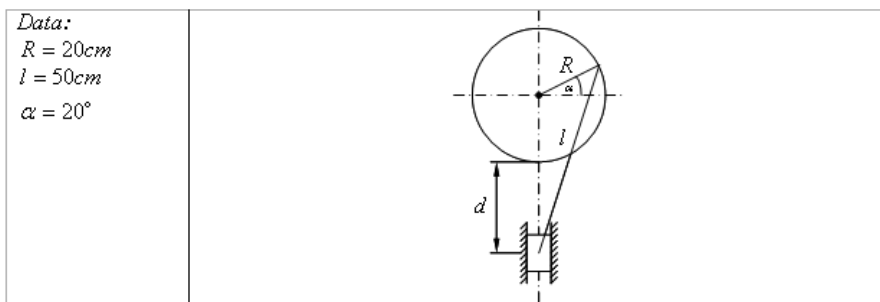

Figure 2

Example 3.2. Three forces act on a screw-head as it is shown in figure. The magnitudes of the forces and their angles relative to the x-axis are given. (Figure 3)

- Calculate the coordinates of the resultant of the three forces.
- Calculate the magnitude of the resultant and its angle relative to the x-axis.
- Construct the resultant of the three forces.

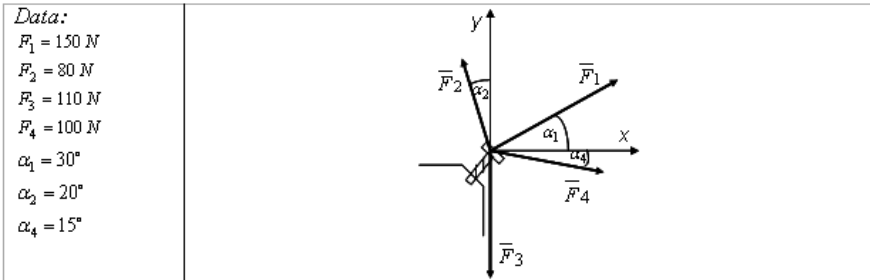

Figure 3

In the book, the same terms and terminology are used, as in the subjects, where the mathematical tools are applied. It is especially important for the students to be able to easily realize, that they meet with the same tools in mathematics as in the other subjects.

4. Results

Mathematics I in the new approach was attended by 105 students, 58 mechanical engineering, 28 building engineering, 16 architect and 3 engineering manager students, in the first semester of 2009/10. At the end of the semester we asked 91 students to take part in our opinion poll about the course book and our new way of teaching Mathematics I. The survey showed that 5,5% of our students consider Mathematics I. to be the most difficult among all the subjects of the first semester, and 50,5% of them see it as one of the three most difficult ones. Our course book “Mathematical Tools in Engineering Applications” was regarded as “easily understandable” by 59,3% of them, and 96,7% of them find it useful in understanding mathematics and also in their further studies (Figure 4).

84,6% of the students declared that the engineering problems helped him in the understanding of mathematics (Figure 5). In the opinion of 27,5% of them accomplishing Mathematics I is more difficult using engineering problems (Figure 6) and 37,4% of the questioned ones said that solving engineering problems is more difficult than mathematical ones (Figure 7). Only 37% of the students said that his secondary school knowledge is a good basis for the understanding of mathematics

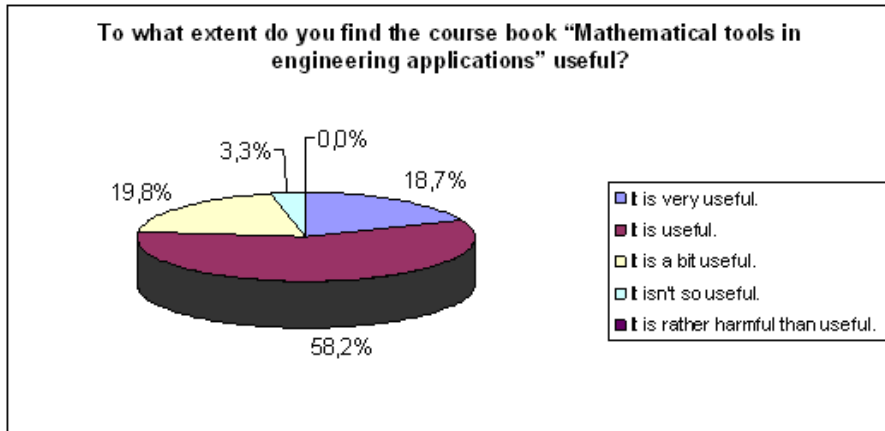

Figure 4

in the first semester. In the opinion Linear functions and transformations, Complex numbers, Vector algebra were the three most difficult topics; and Plane geometry, Matrices and Space geometry were the three easiest topics.

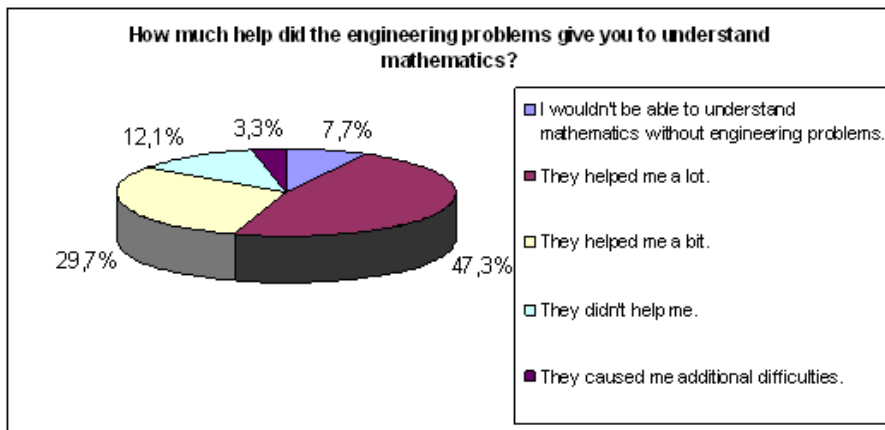

Figure 5

Mechanical Engineering students took the course in Engineering Physics in the first semester of 2009/10, parallel with Mathematics I. From the total 288 Mechanical Engineering students 47 chose to learn mathematics in the new approach. In the midterm writing tests of Engineering Physics we asked exercises from the following topics: free and constrained motion of a particle, electrostatics and DC currents, heat transport (conduction, convection, radiation). The average achievement of the total 288 students in Engineering Physics was 37,7%. The average achievement of

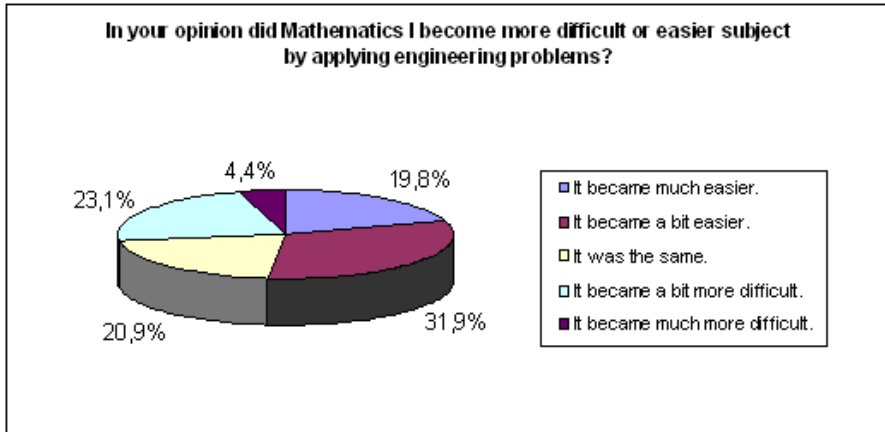

Figure 6

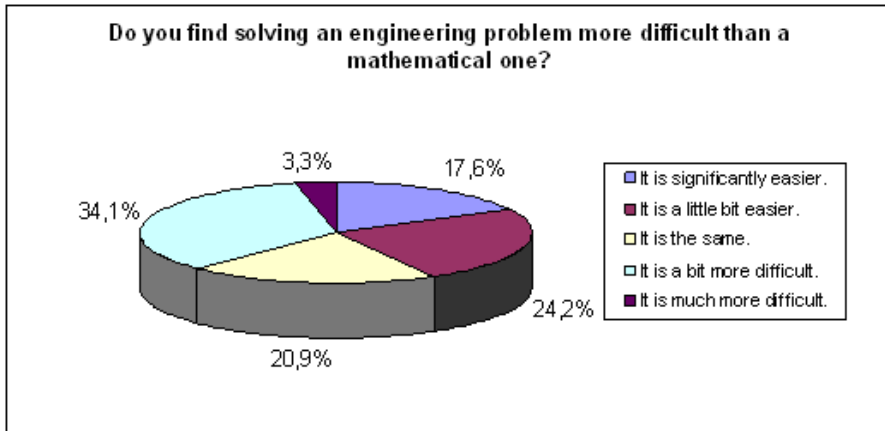

Figure 7

the 47 among them, who attended Mathematics I in the new approach, was better, 42%. The students of Mathematics I in new approach were 1% better in the tasks free and constrained motion of a particle, 6% better in the tasks electrostatics, 4% better in the tasks DC currents, and 7% better in the tasks heat transport. Both groups managed to solve DC currents tasks the best of all. Figure 9 shows the result of tests.

Building Engineering students took the course in Engineering Physics in the second semester. From the total 122 students, 19 attended Mathematics I in the new approach. In the midterm writing tests of Engineering Physics we asked exercises from the following topics: free and constrained motion of a particle, ideal

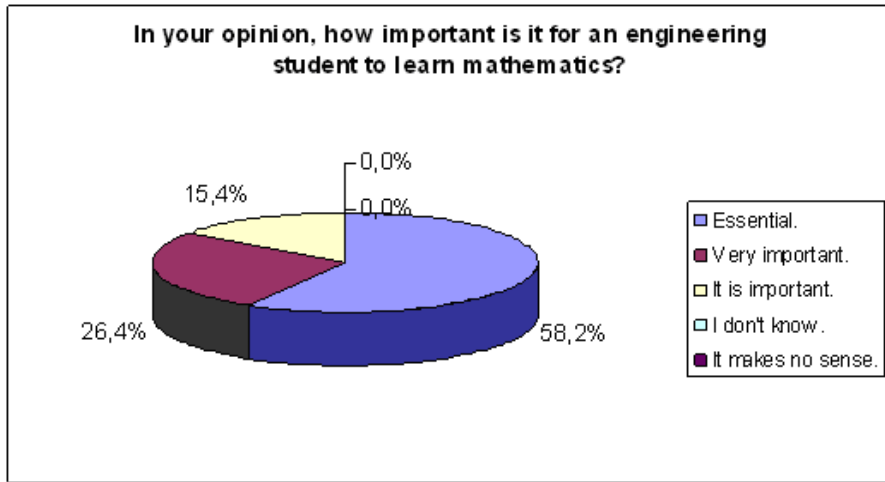

Figure 8

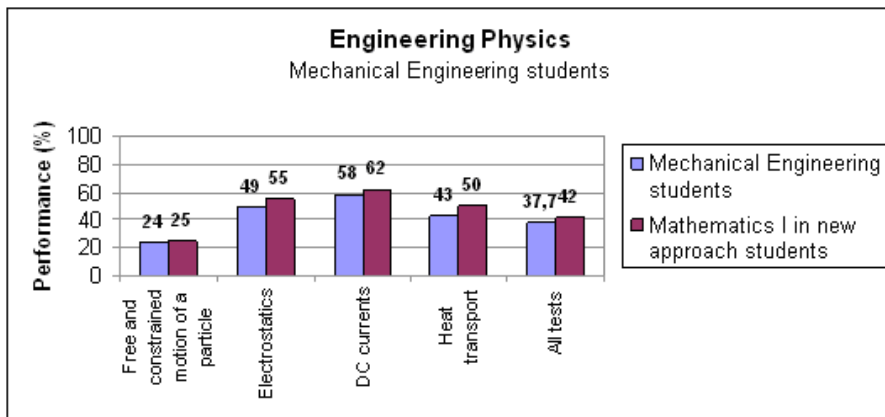

Figure 9

gases and gas mixtures, the processes of ideal gases, heat transport (conduction, convection, radiation). The average achievement of the total 122 students was 54%. The average achievement of those 19 students who attended Mathematics I in the new approach was slightly better, 57%. The students of Mathematics I in new approach were 1% better in the tasks free and constrained motion of a particle, 7% better in the tasks ideal gases, 6% better in the tasks heat transport. The low rate of fulfilling the first tasks show, that the problem solving ability of Mechanical Engineering students and Building Engineering students is poor in the field of free and constrained motion of a particle. We found that there is enough time devoted

for teaching of heat transport in Mathematics I in the new approach. The students of Mathematics I scored their worst in the task related to processes of ideal gases. We can admit that there is little time devoted for teaching of processes of ideal gases in Mathematics I. Figure 10 shows the result of tests.

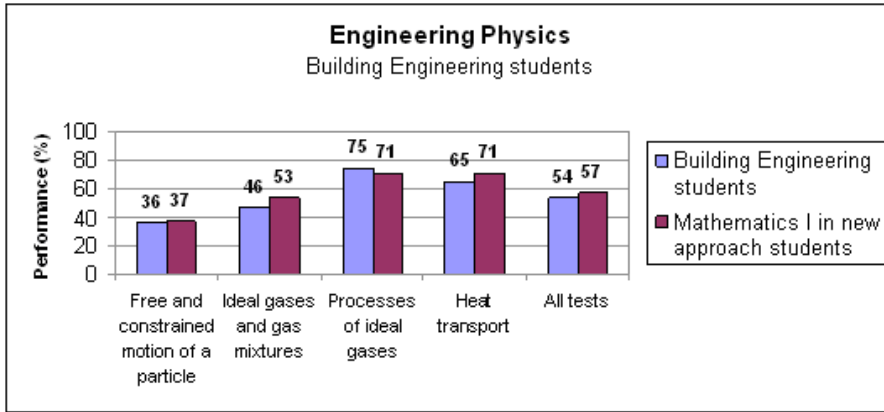

Figure 10

Mechanical Engineering students could take the course in Engineering Mechanics II (Statics II) in the second semester of 2009/10, provided that they had accomplished Engineering Mechanics I before. In the midterm writing test of Engineering Mechanics II we asked exercises from the following topics: state of stress, state of strain, general Hooke’s law, Betti-theorem, Castigliano-theorem. From the total 89 students 24 had attended Mathematics I in the new approach. The average achievement of the 89 students was 32,6%. The average achievement of those 24 among them who attended Mathematics I in the new approach was significantly better, 37,2%.

Mechanical Engineering students could take the course in Engineering Mechanics III (Kinematics and Kinetics) in the first semester of 2010/11, provided that they had accomplished Engineering Mechanics I and II before. In the midterm writing tests of Engineering Mechanics III we asked exercises from the following topics: free and constrained motion of a particle, free and constrained motion of a rigid disk. From the total 44 students 10 had attended Mathematics I in the new approach. The average achievement of the 44 students was 34,7%. The average achievement of those 10 among them who attended Mathematics I in the new approach was significantly better, 44,5%. The students of Mathematics I in new approach were 10,5% better in the tasks free and constrained motion of a particle, and were 9,2% better in the tasks free and constrained motion of a rigid disk. In this exercise was the biggest difference between the two groups. We can admit that there is enough time devoted for teaching of free and constrained motion in Mathematics I in the new approach. Figure 11 shows the result of tests.

So we can say that we can reach quality improving with using Mathematics

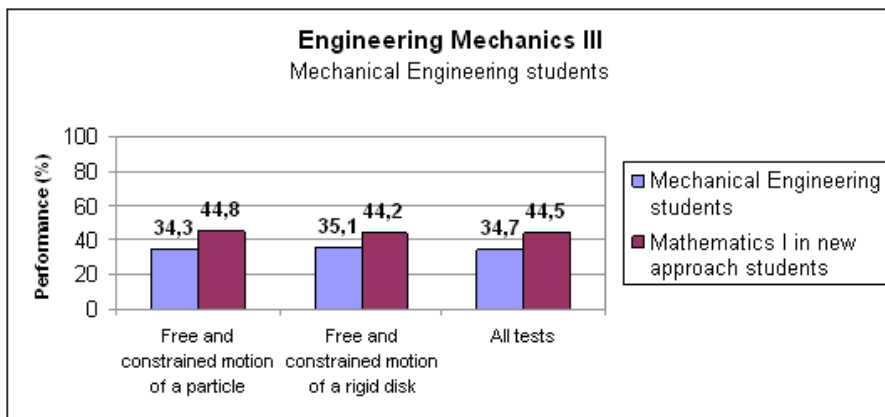

Figure 11

I in the new approach. Organizing the education in this way takes much more time of the teacher, the effective usage of engineering problems requires continuous developing work, but the results of the tests show that the invested work returns. We can talk about mathematical knowledge only in case of those students who can use the definitions and titles in practice as well.

5. Summary

The presented course book has been written for the lectures and seminars of the subject Mathematics I, which is in the syllabus of the Faculty of Engineering, University of Debrecen. The book has an unusual approach to the curriculum in mathematics. This course book underline that why it so important to learn mathematical methods and concepts and where can you use these. The main motive of the authors for writing the course book “Mathematical Tools in Engineering Applications” and for introducing a new kind of teaching method that uses real engineering problems was to make the teaching of mathematics more effective.

We built several important applications from the syllabi of Engineering Mechanics, Physics and Economics into the lectures and seminars of Mathematics. We hope that using this new educational method and the new course book the relationship between Mathematics and the different special engineering subjects becomes more and more clear for our students. In the future, we plan to further develop and revise our new study material on the basis of continual feedback.

On the basis of our results we can conclude that the teaching of mathematics becomes more effective applying engineering problems beside mathematical ones. The achievement and motivation level of students increase this way, and the results of them will be better also in the other engineering subjects that require mathematical knowledge.

If a student studies the book again and again, the connection between mathematics and the other subjects will be clearer for him or her.

References

- [1] KÖRTESEI, P., ed. Proceedings of the 10th Sefi-MWG European Seminar on Mathematics in Engineering Education, *Computer-Aided Design*, June 14-16, Miskolc (2002) 139.
- [2] KÖRTESEI, P., A matematika oktatása mérnökhallgatóknak, *Doktori (PhD) értekezés, Debreceni Egyetem*, (2005)
- [3] MATHEMATICS WORKING GROUP OF SEFI, <http://sefi.htw-aalen.de>
- [4] NAGY-KONDOR, R., Special characteristics of engineer students' knowledge of functions, *International Journal for Mathematics Teaching and Learning*, 10 (2005) 1–9.
- [5] NAGY-KONDOR, R., SZIKI, G. Á., Mathematical tools in engineering applications, *33rd International Congress of Teachers of Mathematics, Physics and IT, Conference Volume*, (2009) 50–54.
- [6] NAGYNÉ KONDOR, R., SZIKI, G. Á., Matematikai eszközök mérnöki alkalmazásokban I., *DE MK*, (2009)
- [7] SASHALMINÉ K., É., Egy felmérés tanulságai, *Acta Acad. Paed. Agriensis, Sectio Mathematicae*, 26 (1999) 121–126.
- [8] SUTHERLAND, R., POZZI, S., The changing Mathematical Background of Undergraduate Engineers, *The Engineering Council, London* (1995)
- [9] SZIKI, G. Á., HÜSE, E., Statikai problémákból felépülő adatbázis fejlesztése és alkalmazása a műszaki informatika oktatásában, *Proceedings of the 15th Building Services, Mechanical and Building Industry Days International Conference, Debrecen*, (2009) 384–389.
- [10] SZIKI, G. Á., Számítógépes program elektromobilok menetdinamikai jellemzőinek számításához, *16th "Building Services, Mechanical and Building Industry days" International Conference, 14-15 October 2010, Debrecen, Hungary*, (2010)
- [11] VANCÓS, Ö., Élő matematika, *Új Pedagógiai Szemle*, 10 (2002) 1–7.
- [12] VÍZVÁRI, B., Új didaktikai és erkölcsi dilemmák a matematika egyetemi oktatásában, *A Matematika Tanítása*, 5 (1998) 11–14.